

DD Platform EuroV Operators Manual

**Models: DD13 Euro V
DD15 Euro V
DD16 Euro V**

Table of Contents

1. Forward	5
2. To the Operator	7
3. Caution Summary	9
4. Engine Identification	19
5. Operating Instructions for Starting the Engine	27
6. Detroit Diesel Electronic Controls (DDEC) System	45
7. Engine Brake System	59
8. Engine Systems	65
9. Aftertreatment System	67
10. Instrument Panel Lamps	71
11. EPA10 Diesel Exhaust Fluid Level Warnings Lamps	75
12. Preventive Maintenance Intervals	77
13. Routine Preventive Maintenance	85
14. How-To Procedures	99
15. Customer Assistance	125
16. Specifications	127

1.01 Introduction.....	6
1.02 Non-Genuine and Rebuilt Component Quality Alert.....	6
1.03 Personnel Requirements	6
1.04 Engine Conversions and Modifications.....	6

1. Forward

1.01 Introduction

This manual is intended for use by the operator of a Detroit™ engine used in On-Highway Vehicle applications.

1.02 Non-Genuine and Rebuilt Component Quality Alert

Electronic engine controls have been instrumental in aiding engine manufacturers meet federal emission requirements and the ever-increasing performance demands of the customer.

Maintenance procedures must be followed in order to continue satisfactory performance and durability and to ensure coverage of the engine under the manufacturer's warranty. Many of these maintenance procedures also ensure that the engine continues to comply with applicable emissions standards. Proper maintenance procedures, using specific components engineered to comply with emissions regulations, may be performed by an authorized Detroit™ distributor or dealer, an independent outlet or the operator or owner. The owner is responsible for determining the suitability of components to maintain emissions compliance during the engine's useful emission life.

Detroit™ cautions that the indiscriminate rebuilding of precision components, without the benefit of specifications, specialized equipment, and knowledge of the electronic operating system, will jeopardize performance or lead to more serious problems, and can take the engine outside of compliance with emission standards.

There are several other components in an engine, including but not limited to the turbocharger, camshaft, piston, diesel exhaust fluid pump, which are specifically designed and manufactured to exacting standards for emissions compliance. It is important that these components, if replaced, modified or substituted, can be verified thus ensuring that the engine remains in compliance with emissions standards. The use of inadequately engineered, manufactured or tested components in the repair or rebuild of the engine may be in violation of federal regulations.

Furthermore, modern engines exhibit operating parameters which require the use of proper fluids, such as fuel, coolant and lubricating oil, to maintain long engine life. The use of fluids that do not meet Detroit™ specifications may result in premature wear or engine failure.

1.03 Personnel Requirements

Work on the engine should be carried out only by skilled technicians who have been instructed in the specific skills necessary for the type of work being performed.

1.04 Engine Conversions and Modifications

The function and safety of the engine could be affected if unauthorized modifications are made to it. Detroit™ will not accept responsibility for any resulting damage.

Tampering with the fuel injection system and engine electronics could also affect engine power output or exhaust emission levels. Compliance with the manufacturer's settings and with statutory environmental protection regulations cannot then be guaranteed.

2.01 To the Operator8

2. To the Operator

2.01 To the Operator

This manual contains instructions on the safe operation and preventive maintenance of your Detroit™ engine used in vehicle applications. Maintenance instructions cover routine engine services such as lubricating oil and filter changes in enough detail to permit self-servicing, if desired.

The operator should become familiar with the contents of this manual before operating the engine or carrying out maintenance procedures.

Power-driven equipment is only as safe as the person operating the controls. You are urged, as the operator of this diesel engine, to keep fingers and clothing away from the revolving belts, drive shafts, pulleys, etc. on the engine installation.

Throughout this manual **CAUTIONS** and **WARNINGS** regarding personal safety and **NOTICES** regarding engine performance or service life will appear. To avoid personal injury and ensure long engine service life, always heed these instructions.

Whenever possible, it will benefit you to rely on an *authorized* Detroit™ service outlet for all your service needs from maintenance to major parts replacement. Authorized service outlets worldwide stock factory-original parts.

The information and specifications in this publication are based on the information in effect at the time of approval for printing. Contact an authorized Detroit™ service outlet for information on the latest revision. The right is reserved to make changes at any time without obligation.

Detroit™ engines are built in accordance with sound technological principles and based on state-of-the-art technology.

Despite this, the engine may constitute a risk of damage to property or injury to persons if it is not used for its intended purpose.

The engine should not be modified or converted in an incorrect manner or the safety instructions included in this manual disregarded.

Keep this Operator Manual with the engine installation at all times. It contains important operating, maintenance, and safety instructions.

NOTICE

Failure to maintain the cooling system at required concentrations will result in severe damage to the engine cooling system and related components. Refer to the "Coolant Selections and Maintenance" section.

WARRANTY
The applicable engine warranty is contained in the booklet "Warranty Information for Detroit™ Engines," available from authorized Detroit™ service outlets.

Trademark Information

DDC®, Detroit™, DDEC®, Optimized Idle®, Diagnostic Link®, BlueTec®, POWER Trac®, POWER COOL®, and POWER GUARD® are registered trademarks of Detroit Diesel Corporation. All other trademarks used are the property of their respective owners.

3.01 Caution Summary 10

3. Caution Summary

3.01 Caution Summary

The following cautions must be observed by the operator of the vehicle or equipment in which this engine is installed and/or by those performing basic engine preventive maintenance. Failure to read and heed these cautions and exercise reasonable care for personal safety and the safety of others when operating the vehicle/equipment or performing basic engine preventive maintenance may result in personal injury and engine and/or vehicle/equipment damage.

Engine Operation

Observe the following cautions when operating the engine.

**WARNING:*****PERSONAL INJURY***

To avoid injury from loss of vehicle/vessel control, the operator of a DDEC equipped engine must not use or read any diagnostic tool while the vehicle/vessel is moving.

**WARNING:*****HOT EXHAUST***

During parked regeneration the exhaust gases will be extremely HOT and could cause a fire if directed at combustible materials. The vehicle must be parked outside.

**CAUTION:*****LOSS OF VEHICLE CONTROL***

To avoid injury from the loss of vehicle control, do not use cruise control under these conditions:

- When it is not possible to keep the vehicle at a constant speed (on winding roads, in heavy traffic, in traffic that varies in speed, etc.).
- On slippery roads (wet pavement, ice-or snow-covered roads, loose gravel, etc.).

**WARNING:*****PERSONAL INJURY***

Diesel engine exhaust and some of its constituents are known to the State of California to cause cancer, birth defects, and other reproductive harm.

- Always start and operate an engine in a well ventilated area.
- If operating an engine in an enclosed area, vent the exhaust to the outside.
- Do not modify or tamper with the exhaust system or emission control system.

**WARNING:*****PERSONAL INJURY***

To avoid injury from engine shutdown in an unsafe situation, ensure the operator knows how to override the stop engine condition on a DDEC-equipped unit.

**CAUTION:*****LOSS OF VEHICLE CONTROL***

To avoid injury from loss of vehicle control, do not activate the Engine Brake system under the following conditions:

- On wet or slippery pavement, unless the vehicle is equipped with ABS (anti-lock braking system) and you have had prior experience driving under these conditions.
- When driving without a trailer (bobtailing) or pulling an empty trailer.
- If the tractor drive wheels begin to lock or there is fishtail motion after the Engine Brake is activated, deactivate the brake system immediately if this occurs.

**WARNING:*****BODILY INJURY***

To avoid injury from an explosion, do not use ether or starting fluid on engines equipped with a manifold (grid) heater.

Preventive Maintenance

Observe the following cautions when performing preventive maintenance.

**WARNING:*****PERSONAL INJURY***

To avoid injury when working near or on an operating engine, remove loose items of clothing and jewelry. Tie back or contain long hair that could be caught in any moving part causing injury.

**WARNING:*****PERSONAL INJURY***

To avoid injury when working on or near an operating engine, wear protective clothing, eye protection, and hearing protection.

**WARNING:*****HOT OIL***

To avoid injury from hot oil, do not operate the engine with the rocker cover(s) removed.

**WARNING:*****FIRE***

To avoid injury from fire, contain and eliminate leaks of flammable fluids as they occur. Failure to eliminate leaks could result in fire.

**CAUTION:*****USED ENGINE OIL***

To avoid injury to skin from contact with the contaminants in used engine oil, wear protective gloves and apron.

**WARNING:*****PERSONAL INJURY***

To avoid injury when using caustic cleaning agents, follow the chemical manufacturers usage, disposal, and safety instructions.

**WARNING:*****PERSONAL INJURY***

To avoid injury from hot surfaces, wear protective gloves, or allow engine to cool before removing any component.

**WARNING:*****PERSONAL INJURY***

To avoid injury, use care when working around moving belts and rotating parts on the engine.

**WARNING:*****FIRE***

To avoid injury from combustion of heated lubricating-oil vapors, stop the engine immediately if an oil leak is detected.

**WARNING:*****PERSONAL INJURY***

To avoid injury from contact with rotating parts when an engine is operating with the air inlet piping removed, install an air inlet screen shield over the turbocharger air inlet. The shield prevents contact with rotating parts.

**WARNING:*****HOT COOLANT***

To avoid scalding from the expulsion of hot coolant, never remove the cooling system pressure cap while the engine is at operating temperature. Wear adequate protective clothing (face shield, rubber gloves, apron, and boots). Remove the cap slowly to relieve pressure.

**WARNING:*****FIRE***

To avoid injury from fire, do not smoke or allow open flames when working on an operating engine.

**WARNING:*****FIRE***

To avoid injury from fire from a buildup of volatile vapors, keep the engine area well ventilated during operation.

**WARNING:*****PERSONAL INJURY***

To avoid injury from rotating belts and fans, do not remove and discard safety guards.

**WARNING:*****PERSONAL INJURY***

To avoid injury from slipping and falling, immediately clean up any spilled liquids.

Compressed Air

Observe the following cautions when using compressed air.

**WARNING:*****EYE INJURY***

To avoid injury from flying debris when using compressed air, wear adequate eye protection (face shield or safety goggles) and do not exceed 276 kPa (40 psi) air pressure.

Cooling System

Observe the following cautions when servicing the cooling system.

**WARNING:*****HOT COOLANT***

To avoid scalding from the expulsion of hot coolant, never remove the cooling system pressure cap while the engine is at operating temperature. Wear adequate protective clothing (face shield, rubber gloves, apron, and boots). Remove the cap slowly to relieve pressure.

**WARNING:*****PERSONAL INJURY***

To avoid injury from slipping and falling, immediately clean up any spilled liquids.

Electrical System

Observe the following cautions when jump starting an engine, charging a battery, or working with the vehicle/application electrical system.

**WARNING:*****ELECTRICAL SHOCK***

To avoid injury from electrical shock, do not touch battery terminals, alternator terminals, or wiring cables while the engine is operating.

**WARNING:*****BATTERY EXPLOSION AND ACID BURN***

To avoid injury from battery explosion or contact with battery acid, work in a well ventilated area, wear protective clothing, and avoid sparks or flames near the battery. If you come in contact with battery acid:

- Flush your skin with water.
- Apply baking soda or lime to help neutralize the acid.
- Flush your eyes with water.
- Get medical attention immediately.

**WARNING:*****PERSONAL INJURY***

To avoid injury from accidental engine startup while servicing the engine, disconnect/disable the starting system.

Air Intake System

Observe the following cautions when working on the air intake system.

**WARNING:*****PERSONAL INJURY***

To avoid injury from hot surfaces, wear protective gloves, or allow engine to cool before removing any component.

**WARNING:*****PERSONAL INJURY***

To avoid injury from contact with rotating parts when an engine is operating with the air inlet piping removed, install an air inlet screen shield over the turbocharger air inlet. The shield prevents contact with rotating parts.

Lubricating Oil and Filters

Observe the following cautions when replacing the engine lubricating oil and filter.

**WARNING:*****PERSONAL INJURY***

To avoid injury from slipping and falling, immediately clean up any spilled liquids.

**WARNING:*****FIRE***

To avoid injury from combustion of heated lubricating-oil vapors, stop the engine immediately if an oil leak is detected.

**WARNING:*****FIRE***

To avoid injury from fire, do not smoke or allow open flames when working on an operating engine.

**WARNING:*****FIRE***

To avoid injury from fire from a buildup of volatile vapors, keep the engine area well ventilated during operation.

Fuel System

Observe the following cautions when fueling the vehicle or working with the fuel system.

**WARNING:*****FIRE***

To avoid injury from fire, keep all potential ignition sources away from diesel fuel, including open flames, sparks, and electrical resistance heating elements. Do not smoke when refueling.

**WARNING:*****PERSONAL INJURY***

To prevent the escape of high pressure fuel that can penetrate skin, ensure the engine has been shut down for a minimum of 10 minutes before servicing any component within the high pressure circuit. Residual high fuel pressure may be present within the circuit.

**WARNING:*****FIRE***

To avoid increased risk of a fuel fire, do not mix gasoline and diesel fuel.



WARNING:

FIRE

To avoid injury from fire caused by heated diesel-fuel vapors:

- Keep those people who are not directly involved in servicing away from the engine.
- Stop the engine immediately if a fuel leak is detected.
- Do not smoke or allow open flames when working on an operating engine.
- Wear adequate protective clothing (face shield, insulated gloves and apron, etc.).
- To prevent a buildup of potentially volatile vapors, keep the engine area well ventilated during operation.

Aftertreatment System

Observe the following cautions when servicing the Aftertreatment System (ATS). Be advised that these two labels are attached to the Aftertreatment Device (ATD).



47158

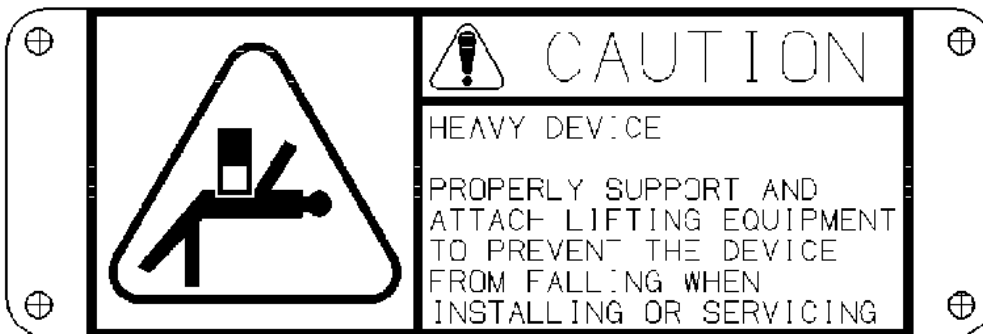

47157

4.01 Engine Components - EuroV DD Platform	20
4.02 Engine Model and Serial Number Designation	23

4. Engine Identification

4.01 Engine Components - EuroV DD Platform

Euro V Platform engine components are shown below:

DD13 Engine Components

For a general view of the Detroit™ engines and major components, see the following:

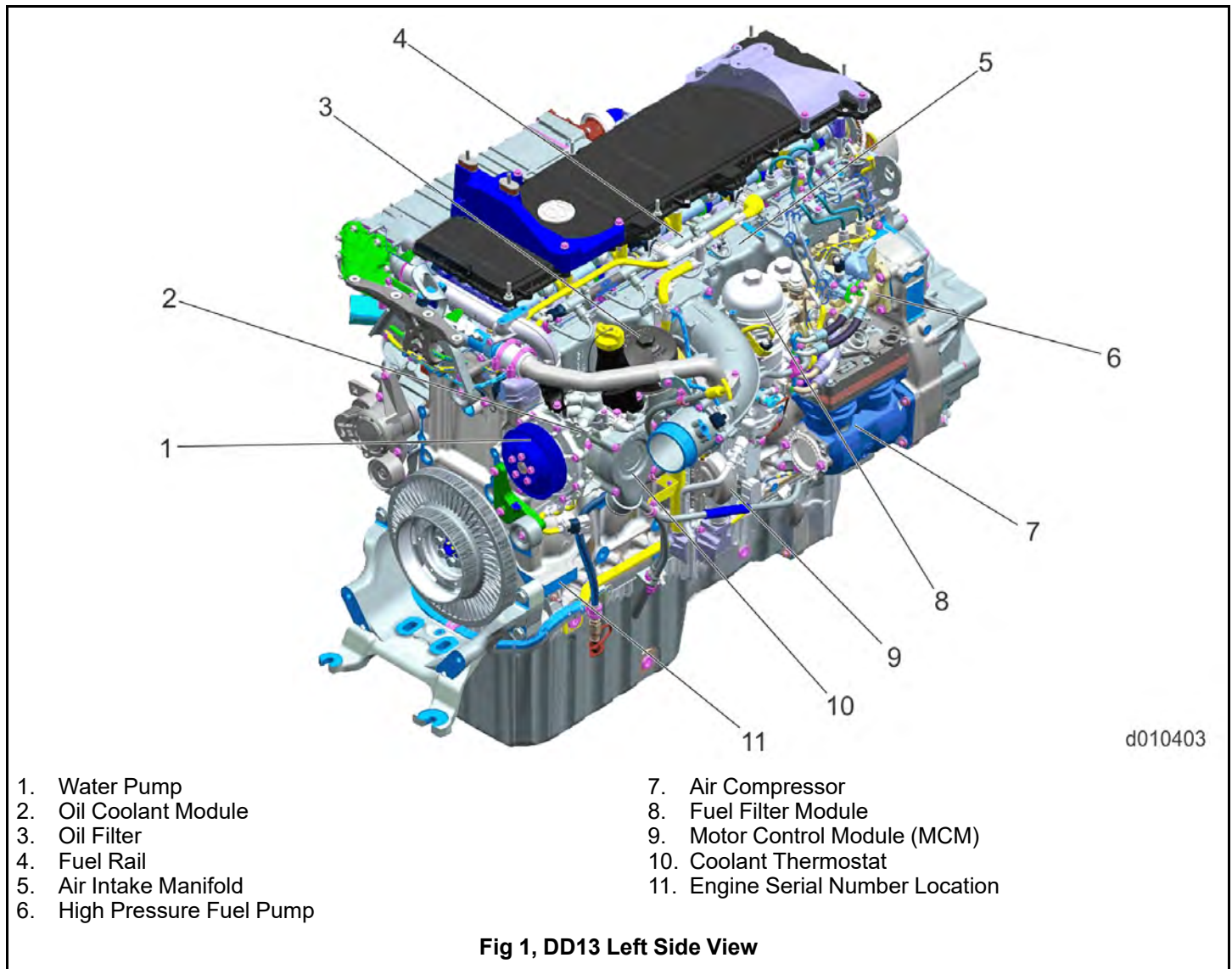

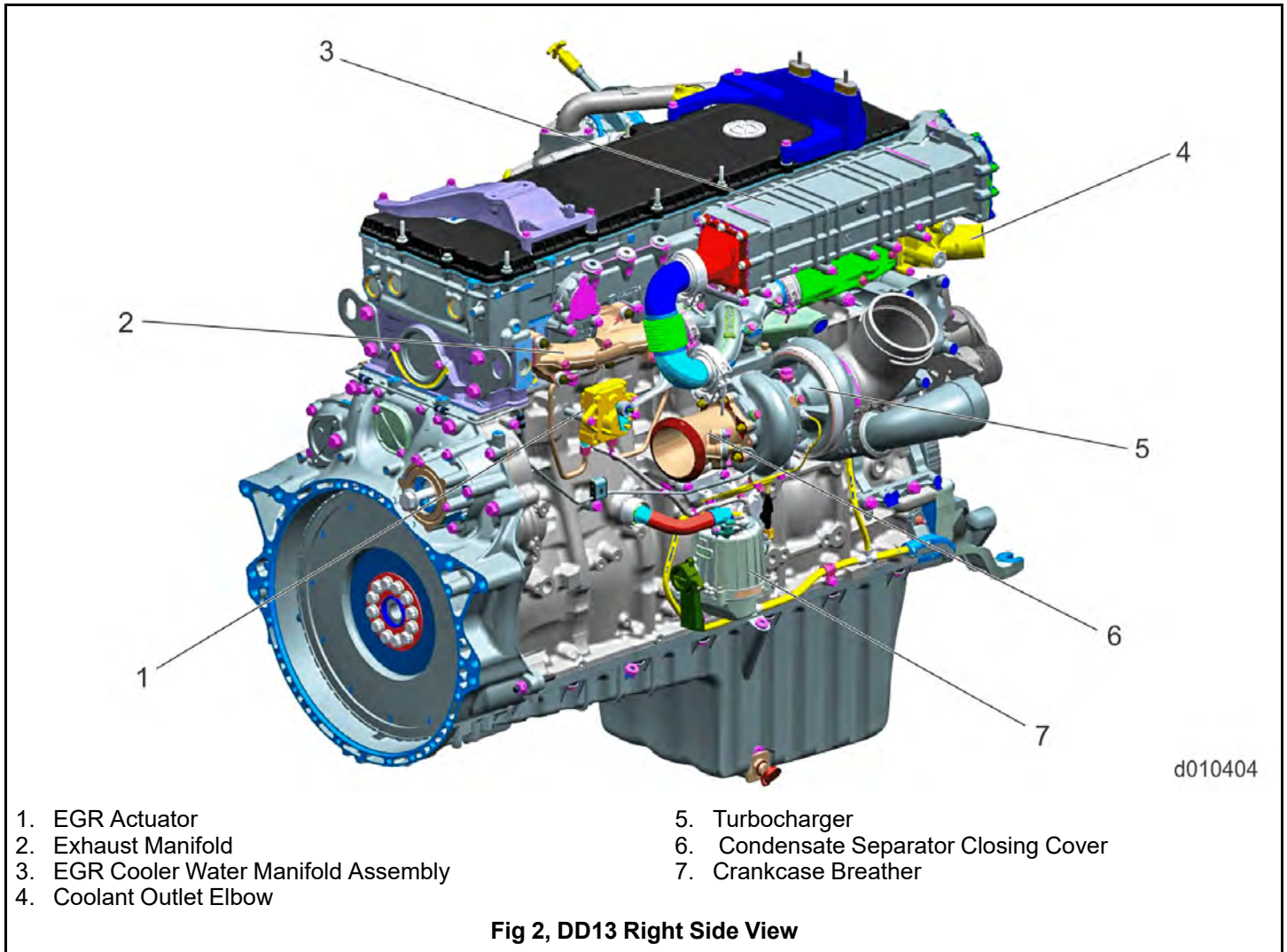

DD16 Engine Components

For a general view of the Detroit™ engines and major components, see the following:

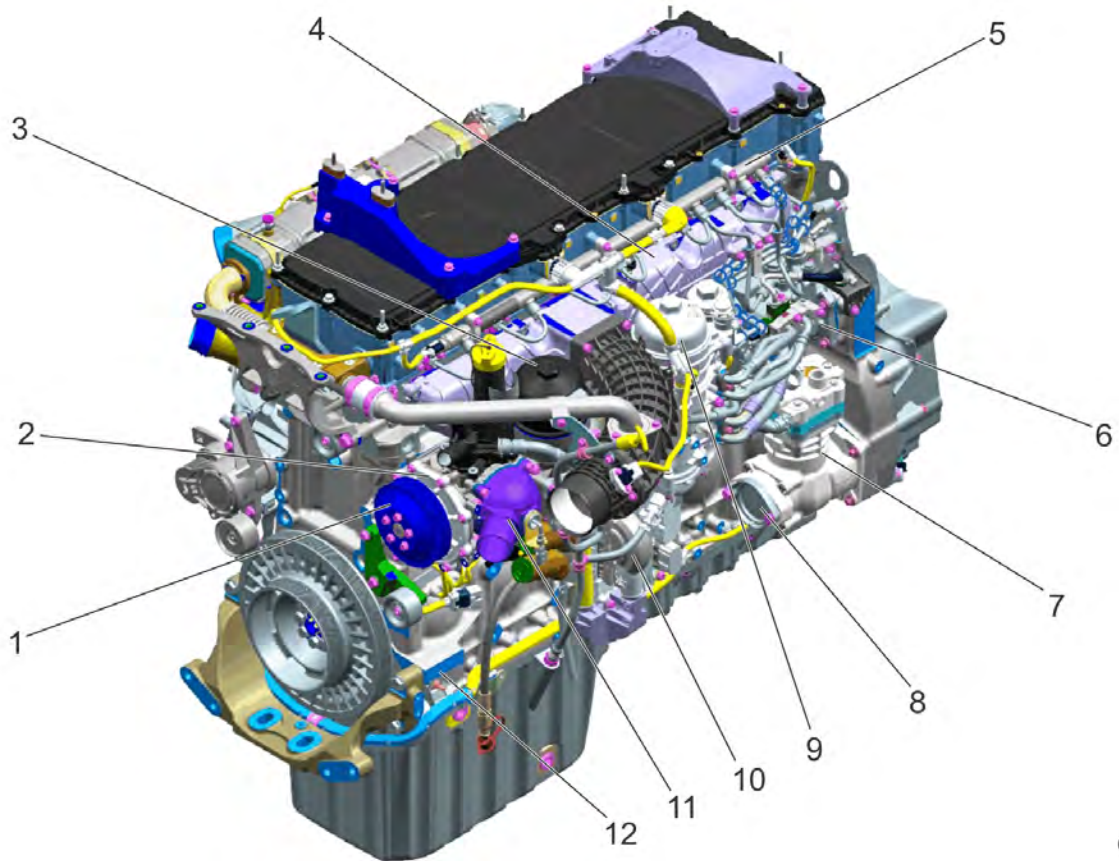

d010405

- 1. Water Pump
- 2. Oil Coolant Module
- 3. Oil Filter
- 4. Air Intake Manifold
- 5. Fuel Rail
- 6. High Pressure Fuel Pump

- 7. Air Compressor
- 8. Power Steering Pump Adaptor
- 9. Fuel Filter Module
- 10. Motor Control Module (MCM)
- 11. Coolant Thermostat
- 12. Engine Serial Number Location

Fig 3, DD16 Left Side View

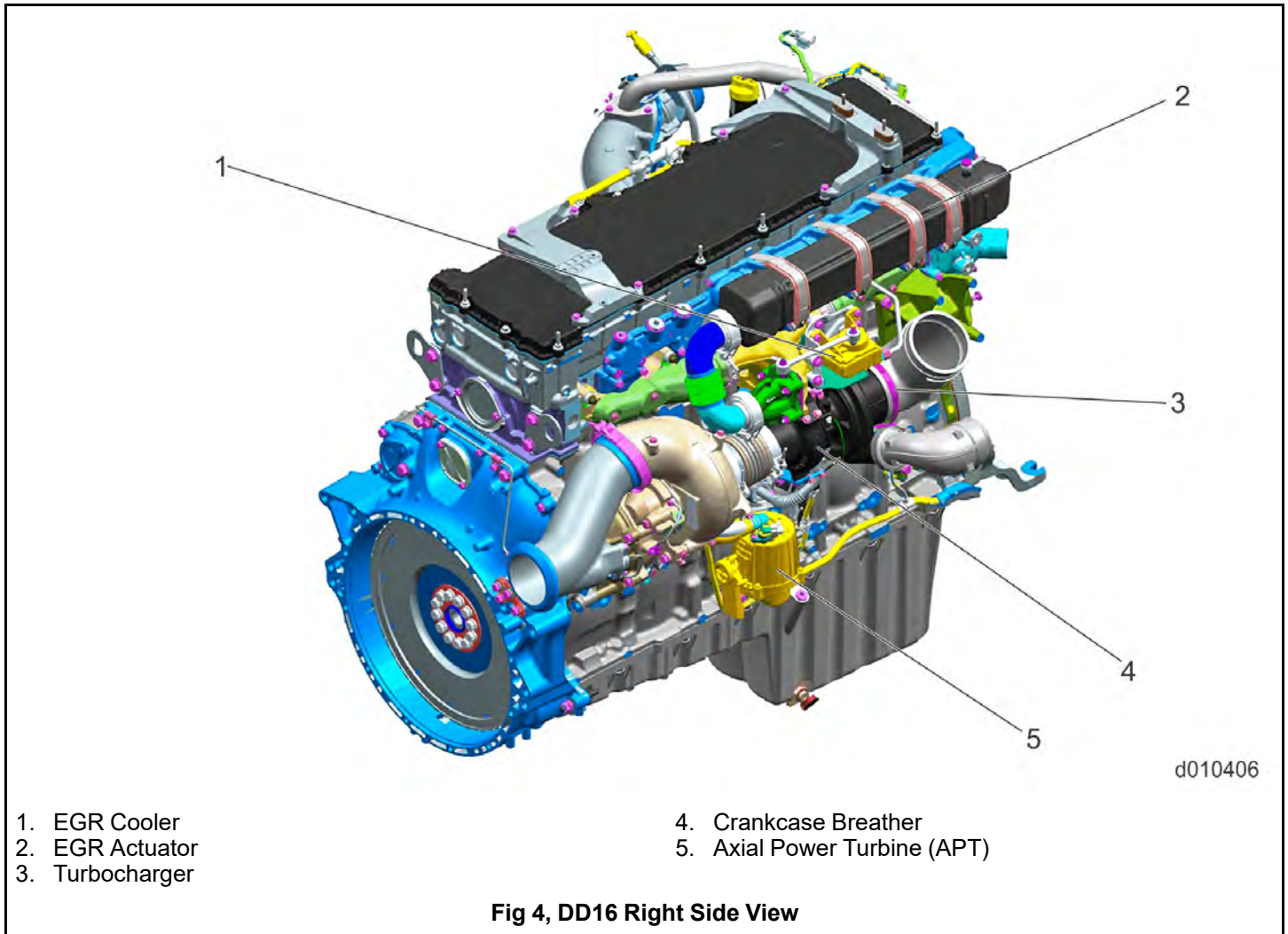

4.02 Engine Model and Serial Number Designation

The following information covers engine model number, serial number and certification label.

Engine Model and Serial Number

The fourteen-digit engine model and manufacturing serial number is etched on a pad located on the left front of the engine cylinder block, above the date and time of manufacture. Using 471928S0485151 as an example:

- 471 = engine model (DD13)
- 928 = vehicle application (Freightliner)
- S = assembly plant (Detroit™)
- 0485151 = serial number

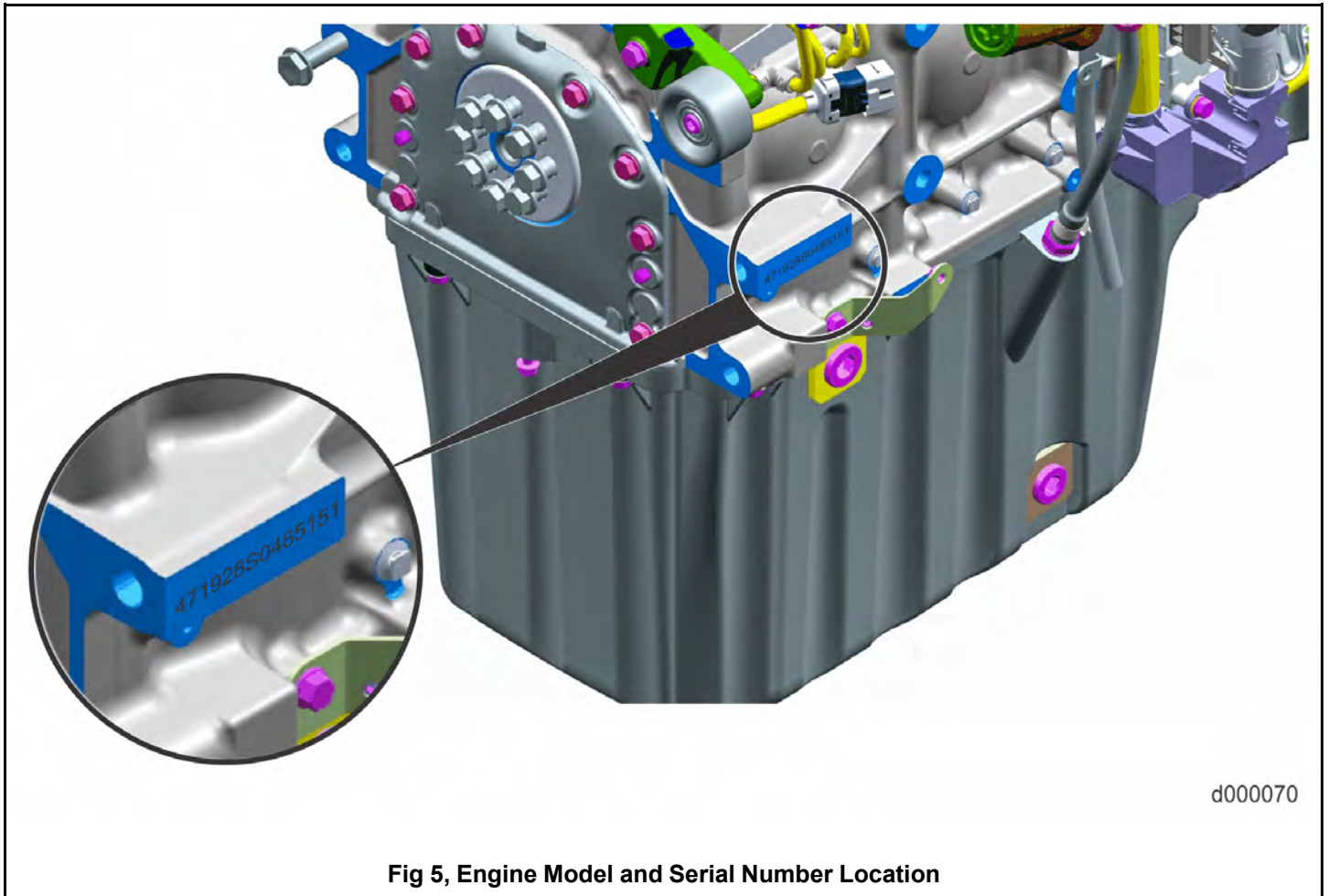

Engine Model Breakdown

- 471 - DD13
- 473 - DD16

Motor Control Module and Engine Serial Number

The Motor Control Module (MCM) part number and Engine Serial Number (ESN) are located on the MCM label.

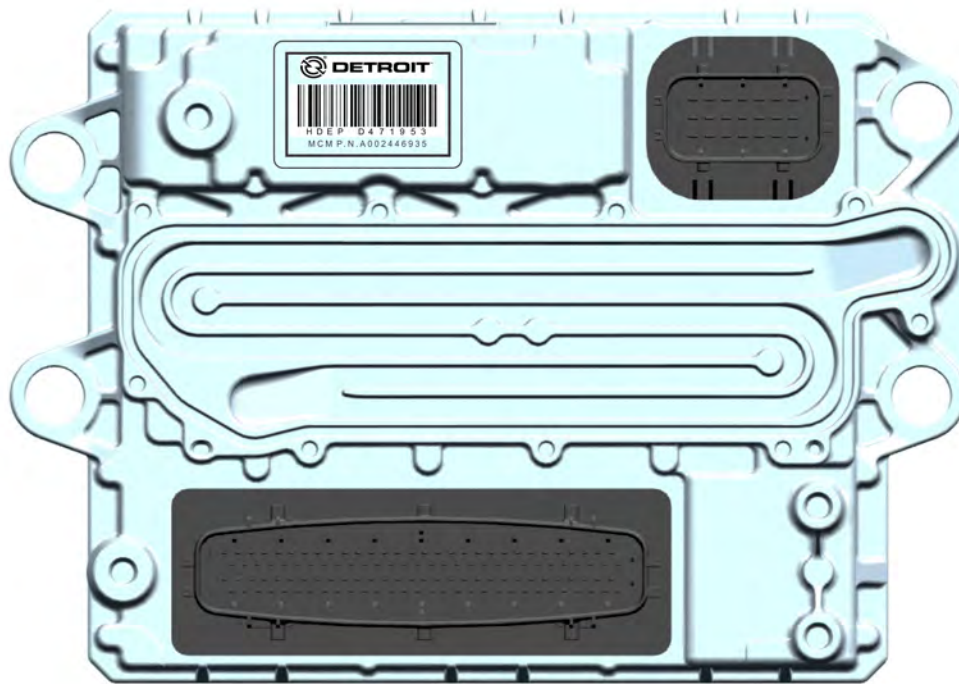

d000071

Fig 6, Motor Control Module Label***Engine Certification Label***

An engine certification label is attached to the engine rocker cover. This label certifies the engine conforms to federal and state emissions regulations for its application. It gives the operating conditions under which certification was made.

The following illustration is an example of an engine certification label.



IMPORTANT ENGINE INFORMATION

FUEL RATE AT AVD. HP XX.X MM3 / STROKE

INITIAL INJECTION TIMING XX.X DEG BTC

ENGINE FAMILY: XX.X

UNIT: xxxxxxxxxxxx

DISP. XX.X LITERS

ADV HP: XX @ XX RPM MODEL: XX.X

MFG. DATE: XXXXXX

MIN IDLE: 600 RPM

VALVE LASH: EXHAUST X.X MM INTAKE X.X MM

“DELEGATED ASSEMBLY”

**EMISSION CONTROL SYSTEMS: DDI, TC, CAC,
ECM, EGR, OC, PTOX, SCR-U, AMOX**

**“FOR USE IN VOCATIONAL OR TRACTOR
VEHICLES”**

**THIS ENGINE CONFORMS TO U.S EPA AND
CALIFORNIA REGULATIONS APPLICABLE TO
2013 MODEL YEAR NEW HEAVY DUTY DIESEL
CYCLE ENGINES. THIS ENGINE HAS A PRIMARY
SERVICE APPLICATION AS A HEAVY DUTY
ENGINE. THIS ENGINE IS NOT CERTIFIED FOR
USE IN AN URBAN BUS AS DEFINED AT 40 CFR
86.093-2. SALE OF THIS ENGINE FOR USE IN AN
URBAN BUS IS A VIOLATION OF FEDERAL LAW
UNDER THE CLEAN AIR ACT. THIS ENGINE IS
CERTIFIED TO OPERATE ON ULTRA-LOW
SULFUR DIESEL FUEL.**

d990003d

Fig 7, Engine Certification Label

5.01 First Time Start Preparations.....	28
5.01.01 System Checks.....	28
5.01.02 Starting the Engine for the First Time.....	34
5.01.03 Starting the Engine	34
5.01.04 Running the Engine.....	35
5.01.05 Stopping the Engine.....	37
5.01.06 Emergency Jump Starting	37
5.01.07 Routine Engine Start	38
5.01.08 Monitoring the Engine Operation.....	41
5.01.09 Changing the Idle Speed	42
5.01.10 Shutting Down the Engine after High Load Operation	42
5.01.11 Emergency Running Mode.....	42
5.01.12 Stop Engine Override Option	42
5.01.13 Cold Weather Operation.....	43

5. Operating Instructions for Starting the Engine

5.01 First Time Start Preparations

When preparing to start a new (or newly overhauled) engine, which has been in storage, perform all of the operations listed below. Failure to follow these instructions may result in serious engine damage.

Be sure you are familiar with all of the instruments, gauges and controls which are needed to operate the engine.

Note especially the location and function of the following:

- Oil pressure gauge
- Low oil pressure warning light
- Coolant temperature gauge
- High coolant temperature warning light
- Water-in-Fuel warning light in the side of the fuel filter module
- Air restriction indicator

Watch for any signs of engine problems when starting or driving. If the engine overheats, uses excessive fuel or lubricating oil, vibrates, misfires, makes unusual noises or shows an unusual loss of power, turn the engine off as soon as possible and determine the cause of the problem. Engine damage may be avoided by a quick response to early indications of problems.

When starting the engine in cold weather, [Cold Weather Operation](#)

5.01.01 System Checks

Perform the following system checks before starting for the first time.

Checking the Cooling System

Check the cooling system as follows:

1. Make sure all drain cocks in the cooling system are installed (drain cocks are often removed for shipping) and are closed tightly.
2. Fill the coolant overflow surge tank with a DFS 93K217 approved coolant until the coolant level stays between the low and full coolant marks on the tank.
3. Entrapped air must be purged after filling the cooling system. To do this, allow the engine to warm up with the pressure cap removed. With the transmission in neutral, increase engine speed to 1000 rpm and add coolant to the surge tank as required.
4. Check to make sure the front of the radiator and charge air cooler (if equipped) are unblocked and free of debris.

Lubrication System Checks

The lubricating oil film on the rotating parts and bearings of a new or newly overhauled engine, or one which has been in storage for six months or more, may be insufficient when the engine is started for the first time.

[Pre-Lubricating the Engine](#)

To ensure an immediate flow of oil to all bearing surfaces at initial engine startup, prepare the engines as follows:

1. Charge the engine lubrication system with lubricating oil using a commercially-available pressure pre-lubricator.
2. Charge the engine lubrication system with lubricating oil using a commercially-available pressure pre-lubricator. Use only the heavy-duty oils recommended in the "How to Replace the Lubricating Oil and Oil Filter" section in this manual.
3. After pre-lubricating, check the engine oil level. If necessary, top off by filling engine oil no more than 5.0 L (5.2 qt) at a time through the oil fill cap to the satisfactory fill range on the oil dipstick. Do not overfill.

Checking and Monitoring the Oil Level

Check the oil level as follows:

**WARNING:*****PERSONAL INJURY***

To avoid injury from slipping and falling, immediately clean up any spilled liquids.

NOTICE

Do not add oil if the oil reading is in the crosshatch area on the dipstick. There are approximately 5.0 L (5.2 qt) from the fill mark to the full mark. Overfilling the oil pan can cause engine damage.

NOTE: If the engine operating temperature is below 60°C (140°F), the engine must be on a level surface and then shut down for 60 minutes for an accurate oil level reading. Otherwise, the engine must be brought up to an operating temperature of 60°C (140°F), parked on a level surface and then shut down for five minutes for an accurate oil level reading.

1. Check the oil level daily with the engine stopped and on a level surface. If the engine has just been stopped and is warm, wait approximately 20 minutes to allow the oil to drain back into the oil pan before checking.
2. Add oil to maintain the correct level on the dipstick. Use only the heavy-duty oils recommended in the "How to Replace the Lubricating Oil and Oil Filter" section in this manual.
3. Remove the dipstick from the guide tube. Use a shop rag to wipe off the end of the dipstick.
4. Wait 15 seconds to allow any crankcase pressure to dissipate through the guide tube and let the oil level settle in the oil pan.
5. Reinstall the dipstick and make sure it is fully inserted into the guide tube.
6. Remove the dipstick and read the oil level dipstick.
7. The figure shows a comparison between the bends on the dipstick and a crosshatch pattern on a conventional dipstick. Note the exact area noted on the bends. For example, the 'maximum' oil level will be at the BOTTOM of that bend. For the 'minimum' oil level, it is noted at the TOP of the bend. If the oil level is below the 'minimum' bend, add oil to bring it up the 'maximum' level. Do NOT fill beyond the maximum fill level on the dipstick, since overfilling may result in high oil consumption and possible severe engine damage.

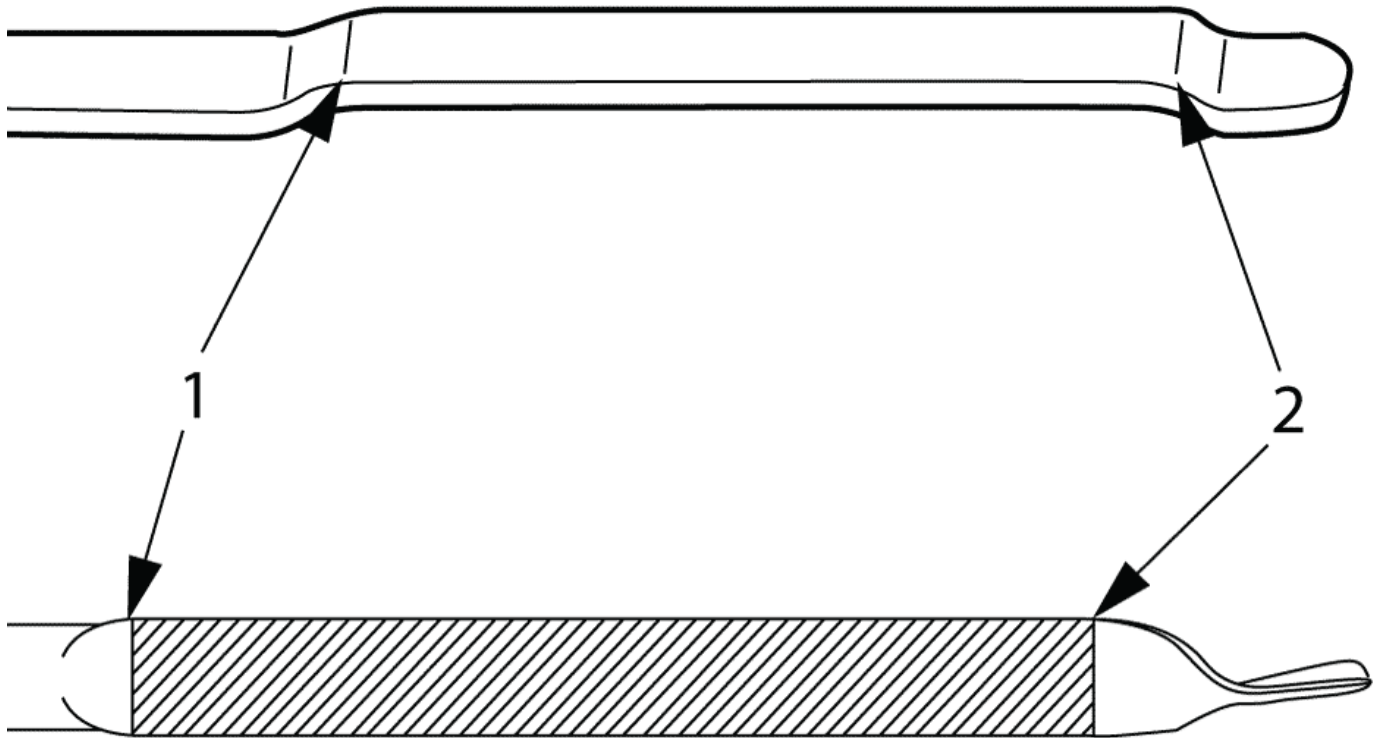

42141

After an Extended Storage

NOTICE

Failure to eliminate water-diluted lubricating oil may lead to serious engine damage at startup.

An engine in storage for an extended period of time (over winter, for example) may accumulate water in the oil pan through normal condensation of moisture (always present in the air) on the cold, internal surfaces of the engine.

Lubrication oil diluted by water cannot provide adequate bearing protection at engine startup. For this reason, Detroit™ recommends replacing the engine lubricating oil and filters after extended storage.

Fuel System Checks

Make sure the fuel shutoff valve (if used) is open. Fill the tanks with the recommended fuel. Keeping tanks full reduces water condensation and helps keep fuel cool, which is important to engine performance. Full tanks also reduce the chance for microbe (black slime) growth. For fuel recommendations, [How to Select Diesel Fuel](#).

NOTICE

Prolonged use of the starting motor and engine fuel pumps to prime the fuel system can result in damage to the starter, fuel pumps, and injectors.

If the shutoff valve is even partially closed, it may cause erratic engine operation due to an inadequate supply of fuel to the fuel pump.

NOTICE

NEVER use ether as a starting aid to run the engine. Doing so will result in injector damage.

If an external starting aid is used, such as a starting fluid, the heat generated by the external fuel source will cause the injector tips to be damaged when the fuel cools them. The injector piston and bushing can be scored from running without lubrication.

To ensure prompt starting and even running, the fuel system must be primed if air has entered the fuel system. Priming is done by operating the manual hand priming pump located on the fuel filter module or connecting an external priming pump to the priming port on the fuel filter module.

Authorized Detroit™ service outlets are properly equipped for this type of service.

Priming is required if the fuel system has been serviced.

Drain off any water that has accumulated. Water in fuel can seriously affect engine performance and may cause engine damage.

[Adding Fuel](#)

When adding fuel, pay attention to the following:

NOTICE

To ensure maximum engine performance for **GHG17** applications, always use Ultra-Low Sulfur Diesel Fuel (ULSD) with 15 PPM sulfur content or less, based on ASTM Standard D2622 test procedure. Higher sulfur levels will damage the engine Aftertreatment System (ATS).

NOTICE

To ensure maximum engine performance for **EuroV** applications, Ultra Low Sulfur Diesel fuel (ULSD) (15 PPM sulfur content maximum), based on ASTM Standard D 2622 test procedure is recommended. However, due to varying fuel quality in these markets, up to 50 ppm sulfur diesel fuel is acceptable for this application.

- Add winter or summer grade fuel according to the season of the year.
- Work in the cleanest conditions possible.
- Prevent water from entering the fuel tank.

For further information, see in this manual.

[Priming the Fuel System](#)

Prime the fuel system as follows:

1. Operate the hand primer on module for three minutes or 250 strokes, or use an external priming source such as tool J-47912 or ESOC 350.
2. Crank the engine for 20 seconds.
3. Wait 60 seconds for the starter to cool down.

4. If the engine does not start, repeat step 2 and step 3. The starting cycle can be repeated up to three times.
5. If the engine still fails to start, continue as follows:
 - 5.a Use DDDL to check for fault codes, repair as necessary.
 - 5.b Repeat step 2 and step 3.

**WARNING:*****ENGINE EXHAUST***

To avoid injury from inhaling engine exhaust, always operate the engine in a well-ventilated area. Engine exhaust is toxic.

**WARNING:*****PERSONAL INJURY***

To avoid injury before starting and running the engine, ensure the vehicle is parked on a level surface, parking brake is set, and the wheels are blocked.

6. Start the engine with the accelerator pedal in the idle position. Monitor the oil pressure gauge or indicator lamp. **Keep the engine running at idling speed** until the oil pressure reading is 14 psi (97 kPa) or more.
7. Allow engine to reach operating temperature 60°C (140°F).
8. Increase engine speed to 1800 rpm for three minutes.
9. Return the engine to idle and allow to idle for approximately one minute, then shut down the engine.
10. Check for leaks. Repair if necessary.

Checking Other Engine and ATS Related Parts

Check the engine compartment as follows:

- Make sure the transmission is filled to the proper level with the fluid recommended by the gear manufacturer. Do not overfill.
- The Diesel Exhaust Fluid (DEF) must be checked and filled regularly with DEF meeting Detroit™ quality specification.
- Make sure cable connections to the storage batteries are clean and tight.
- Check for cracks in the battery cases (1), for tightness of the cable clamps (2) at the terminals, and for corrosion of the terminals (3). Service or replace as needed.
- To provide corrosion protection, apply dielectric grease liberally to the terminal pads.

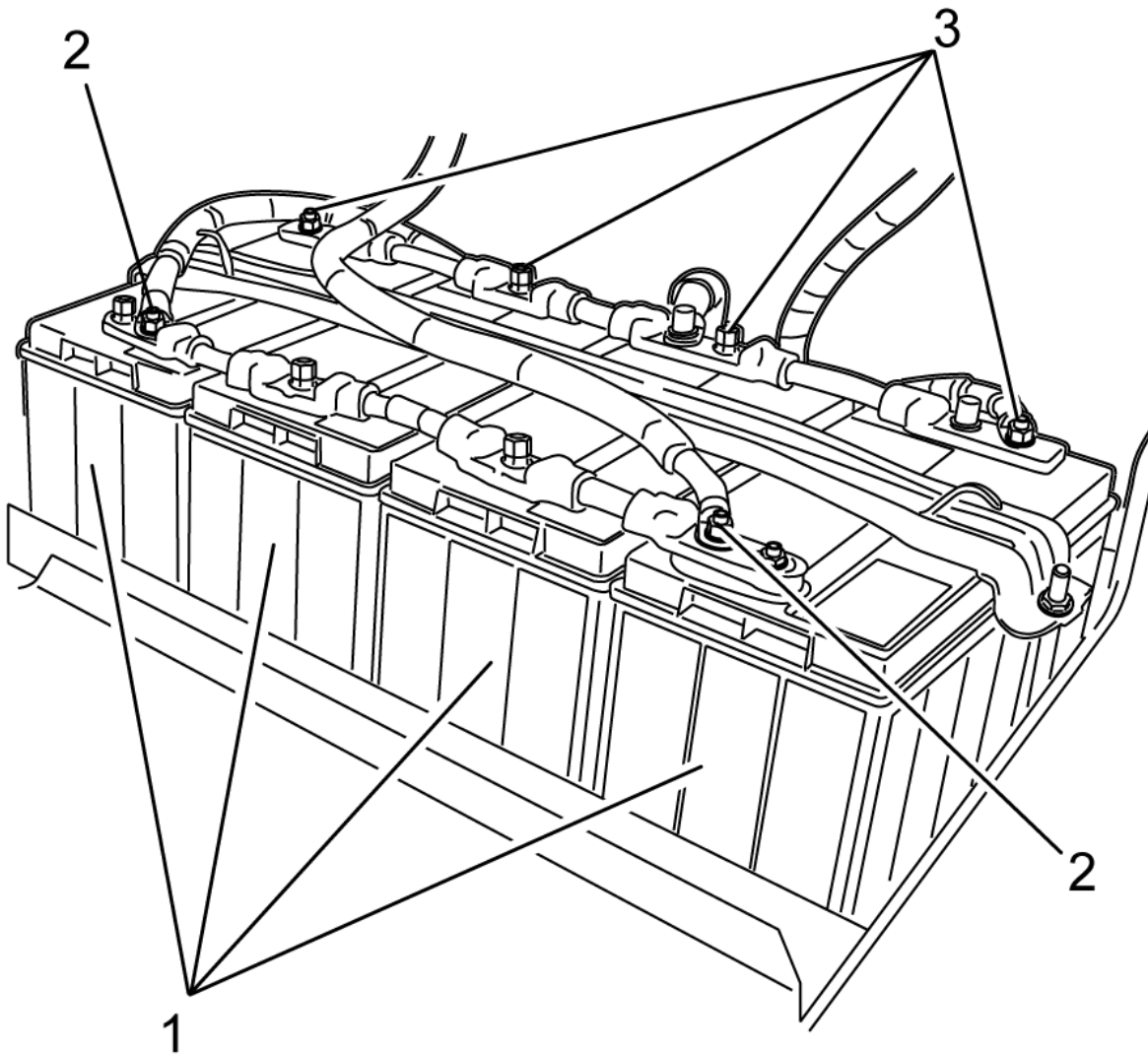

d540077

5.01.02 Starting the Engine for the First Time

**WARNING:*****EXPLOSION***

To avoid injury from explosion, never use ether with an engine's electrical cold starting system.

Before starting the engine the first time, perform an inspection of the engine systems.

To start the engine, the transmission should be in neutral and the ignition key turned to ON.

**WARNING:*****ENGINE EXHAUST***

To avoid injury from inhaling engine exhaust, always operate the engine in a well-ventilated area. Engine exhaust is toxic.

**WARNING:*****PERSONAL INJURY***

To avoid injury when working near or on an operating engine equipped with an hydraulic clutch fan, remove loose items of clothing and jewelry. Tie back or contain long hair that could be caught in any moving part causing injury. The hydraulic fan may start without warning.

You will notice that the Amber Warning Lamp (AWL), Red Stop Lamp (RSL), Malfunction Indicator Lamp (MIL), and High Exhaust Temperature (HEST) lamp will come on. This is the result of the DDEC computer diagnosing the system to ensure everything is functional, including the light bulbs for the warning lights. If everything is OK, all lights will go out in approximately five seconds.

The lights must go out before starting the engine. If starting a vehicle, the operators foot must be *OFF* the accelerator pedal before starting the engine.

NOTICE

If the warning lights stay on, or do not come on momentarily after turning on the ignition, contact your nearest Detroit™ Dealer or Distributor. Operating the engine under these circumstances may result in engine damage.

5.01.03 Starting the Engine

1. Place the transmission in neutral, and set the parking brake.
2. Turn on the ignition switch.
3. Wait for the engine system indicator lights on the instrument panel to go out.
4. With foot off the accelerator pedal, start the engine.
5. If the engine does not start after 20 seconds, stop. Try again after waiting about 60 seconds.
6. Monitor the oil pressure gauge immediately after starting the engine.

5.01.04 Running the Engine

While the engine is operating, monitor the battery charge indicator light, the oil pressure, and avoid excessive idling.

Checking the Oil Pressure

Monitor the oil pressure as follows:

**WARNING:*****HOT OIL***

To avoid injury from hot oil, do not operate the engine with the rocker cover(s) removed.

1. Observe the oil pressure gauge immediately after starting the engine. An oil pressure gauge that registers pressure 14 psi (96 kPa) at idle speed and normal operating temperature is a good indicator that all moving parts are getting lubrication.
2. If no pressure is indicated within 10 to 15 seconds, stop the engine and check the lubrication system at normal operating temperature.
3. The oil pressure should not drop below 55 psi (380 kPa) at 1800 rpm, at normal operating temperature. If oil pressure does not fall within these guidelines, check it with a manual gauge.

Warming Up the Engine

Run the engine at part throttle for about five minutes to allow it to warm up before applying a load.

Inspection During Idling

While the engine is idling, inspect the transmission and crankcase for fluid leaks. On DD15 and DD16 engines, check the Axial Power Turbine (APT) for oil leaks.

Checking the Transmission

While the engine is idling, check the automatic transmission (if equipped) for proper oil level and add oil as required.

Checking for Fluid Leaks

Check for fluid leaks as follows:

1. Look for coolant, fuel, or lubricating oil leaks.
2. If any leaks are found, shut down the engine immediately and have the leaks repaired after the engine has cooled.

Checking the Crankcase

Check the crankcase as follows:

1. If the engine oil was replaced, stop the engine after normal operating temperature has been reached. Allow the oil to drain back into the crankcase for about 60 minutes, then check the oil level.

2. If necessary, add no more oil than 5.0 L (5.2 qt) at a time to bring the level to the proper mark on the dipstick. Use only the heavy-duty oils recommended in the "How to Replace the Lubricating Oil and Oil Filter" section in this manual.

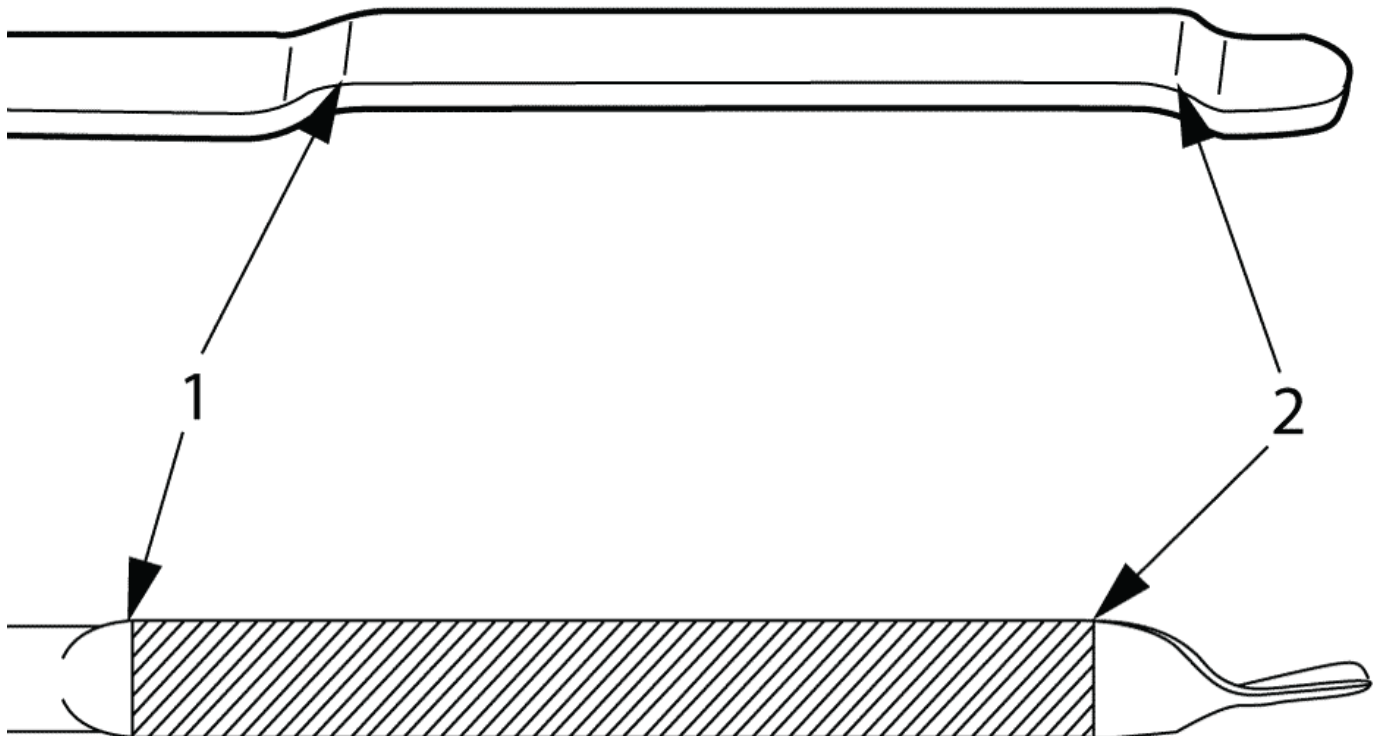

42141

Checking the Turbocharger

Check the turbocharger as follows:

1. Make a visual inspection of the turbocharger for oil leaks, exhaust leaks, excessive noise, or vibration.
2. If a leak, unusual noise, or vibration is noted, stop the engine immediately. **Do not restart the engine until the cause of the concern has been investigated and corrected.**

Checking the Axial Power Turbine

Check the axial power turbine for excessive noise or vibration. Stop the engine immediately if unusual noise or vibration is noted. **Do not restart the engine until the cause of the concern has been investigated and corrected.**

Avoid Unnecessary Idling

Whenever possible, unnecessary idling should be avoided. During long engine idling periods with the transmission in neutral, the engine coolant temperature may fall below the normal operating range. The incomplete combustion of fuel in a cold engine will cause crankcase oil dilution, formation of lacquer or gummy deposits on the valves, pistons, and rings, and rapid accumulation of sludge in the engine. When prolonged idling is necessary, maintain at least 900 rpm.

5.01.05 Stopping the Engine

Stop an engine under normal operating conditions as follows:

NOTICE

Do not stop a turbocharged engine immediately after a high-speed operation. Allow a sufficient cool-down period of about five minutes to prevent the turbocharger from continuing to turn without an oil supply to the bearings or damage can result.

1. Reduce engine speed to idle and put all shift levers in the neutral position.
2. Allow the engine to run between idle and 1000 rpm with no load for five minutes. This allows the engine to cool and permits the turbocharger to slow down. After five minutes, shut down the engine.

5.01.06 Emergency Jump Starting

The engine's electronic system operates on 12 volts DC. If a DD Platform engine with an electric starting motor requires emergency jump starting, **DO NOT EXCEED 16 VOLTS DC.**



WARNING:

BATTERY EXPLOSION

To avoid injury from battery explosion when jump starting the engine, do not attach the cable end to the negative terminal of the disabled battery.



WARNING:

BATTERY EXPLOSION AND ACID BURN

To avoid injury from battery explosion or contact with battery acid, work in a well ventilated area, wear protective clothing, and avoid sparks or flames near the battery. If you come in contact with battery acid:

- Flush your skin with water.
- Apply baking soda or lime to help neutralize the acid.
- Flush your eyes with water.
- Get medical attention immediately.

NOTICE

Jump starting with voltages greater than those indicated or reversing battery polarity may damage the MCM.

NOTICE

Failure to connect jumper cables in the proper sequence can result in alternator and/or equipment damage.

Before attempting to jump start the engine, the jumper cables **must be** connected properly; positive-to-positive, and negative-to-chassis or suitable ground. The proper sequence is to connect negative to negative ground last.

5.01.07 Routine Engine Start

The following are procedures for a routine engine start.

**WARNING:*****ENGINE EXHAUST***

To avoid injury from inhaling engine exhaust, always operate the engine in a well-ventilated area. Engine exhaust is toxic.

**WARNING:*****PERSONAL INJURY***

To avoid injury when working near or on an operating engine equipped with an hydraulic clutch fan, remove loose items of clothing and jewelry. Tie back or contain long hair that could be caught in any moving part causing injury. The hydraulic fan may start without warning.

Routinely Starting the Engine

Before a routine start, see the daily checks for your engine in the Maintenance section of this manual.

**NOTICE:**

Before starting the engine, carefully read all operating instructions in this manual and do all the recommended pre-trip inspections and daily maintenance. Check the coolant, engine oil, and fuel levels, and drain contaminants from the water separator/coalescer.

Start the engine as follows:

NOTE: If you drain water from the water separator/coalescer, you have to prime the fuel system with the built-in hand primer (about 50 strokes).

NOTE: As a safety function, the electronic engine control system may be wired to start the engine only if the transmission is in neutral. This feature is vehicle application specific.

1. Turn on the ignition switch.
2. Wait for the engine system indicator lights on the instrument panel to go out.
3. With the accelerator pedal in the idle position, start the engine.
4. Check the engine for leaks.
 - 4.a Check all hoses, hose clamps, and pipe unions on the engine for tightness. Shut down the engine and tighten them if necessary.

- 4.b Check the oil feed and return lines at the turbocharger for leaks. Shut down the engine and tighten them if necessary.
5. Shut down the engine.

NOTE: If the engine operating temperature is below 60°C (140°F), the engine must be on a level surface and then shut down for 60 minutes for an accurate oil level reading. Otherwise, the engine must be brought up to an operating temperature of 60°C (140°F), parked on a level surface and then shut down for five minutes for an accurate oil level reading.

6. Check the oil level using the oil dipstick. The oil level is measured using the crosshatch area on the dipstick. If the oil reading within the crosshatch area, then the oil is at the proper level for engine operation.

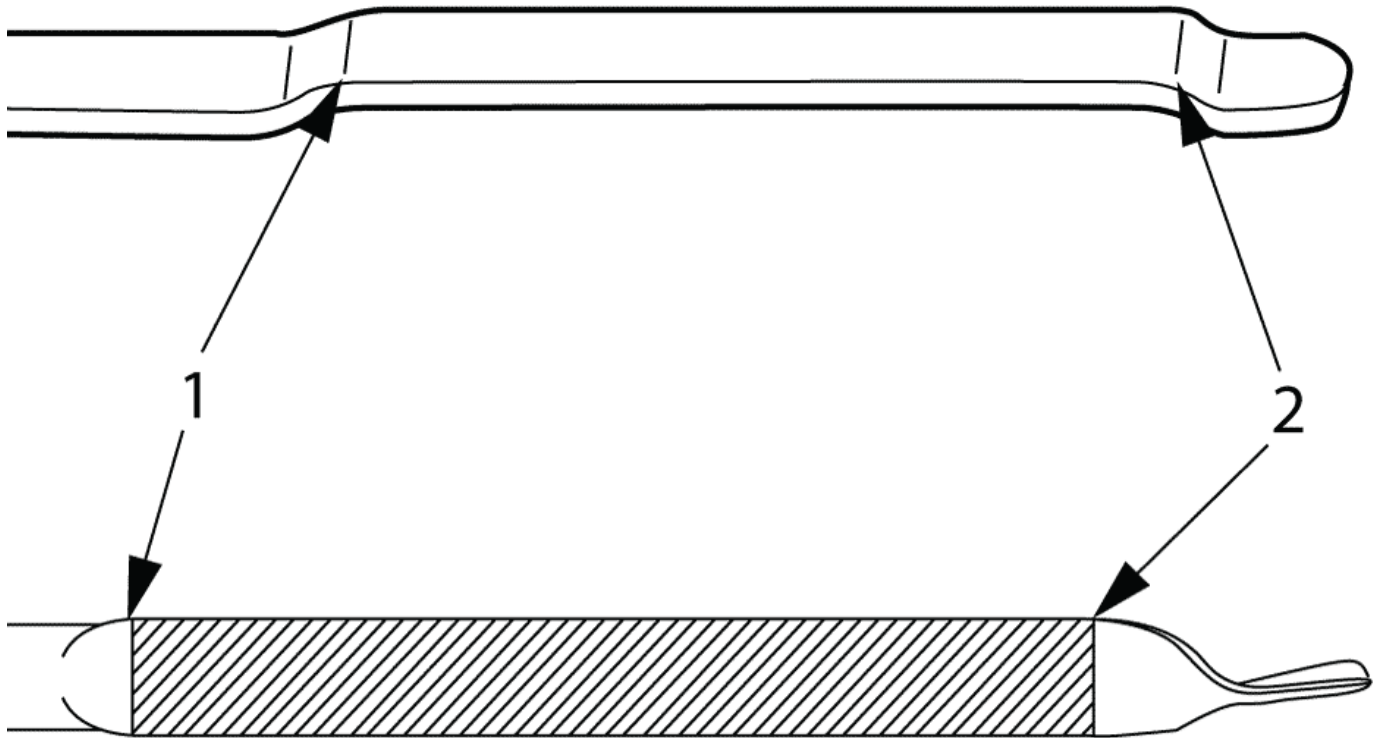

42141

7. Check all the mounting fasteners on the engine for tightness.

Checking the Coolant Level (Cold Check)

Check coolant level as follows:

1. Ensure that all coolant plugs in the bottom of the radiator and on the radiator outlet pipe are secure and tight.
2. Check the coolant level. The cooling system is correctly filled when the coolant is between the full and low marks on the surge tank.

Checking the Coolant Level (Hot Check)

Check the coolant levels as follows:

1. Allow the engine to run for approximately five minutes at a moderate speed.
2. After the coolant temperature reaches 50°C (122°F), recheck the coolant level in the surge tank.

**WARNING:*****HOT COOLANT***

To avoid scalding from the expulsion of hot coolant, never remove the cooling system pressure cap while the engine is at operating temperature. Wear adequate protective clothing (face shield, rubber gloves, apron, and boots). Remove the cap slowly to relieve pressure.

3. Add more coolant if necessary. Open the heater valves before adding coolant.
4. Do not close the heater valves until the engine has been running briefly and the coolant level is again checked and corrected as necessary.

5.01.08 Monitoring the Engine Operation

While the engine is operating, monitor the battery charge indicator light and the oil pressure. Excessive idling should be avoided.

Monitoring the Battery Charging System

The battery charge indicator light must go out once the engine starts. If the indicator light comes on while the engine is running, do the following:

1. Shut down the engine.
2. Test the charging system, per OEM guidelines.

**WARNING:*****BATTERY EXPLOSION***

To avoid injury from battery explosion when jump starting the engine, do not attach the cable end to the negative terminal of the disabled battery.

3. If necessary, visit the nearest authorized dealer to have the alternator voltage and output checked.
4. Do a load test on the batteries.
5. Replace components as needed.

Monitoring the Oil Pressure

When the engine has reached its normal operating temperature, the engine oil pressure must not drop below the following values:

- 55 psi (380 kPa) at rated speed
- 14 psi (97 kPa) at idling speed

If oil pressure drops below these values, stop the engine and determine the cause.

Excessive Idling

Never allow the engine to idle for more than 30 minutes. Excessive idling can cause oil to leak from the turbocharger.

5.01.09 Changing the Idle Speed

The idle speed range of the DD Platform engine is 600 to 900 rpm if the parameters in the CPC are set to the default range. Change the idle speed as follows:

1. Turn the cruise control switch to the ON position.
2. To increase the idle speed, push the RSM/ACC switch until the idle reaches the desired rpm.
3. To decrease the idle speed, push the SET/CST switch until the idle reaches the desired rpm.

5.01.10 Shutting Down the Engine after High Load Operation

If the engine has been running at full output or the coolant temperature has been high, idle the engine for five minutes without load. If any of the following conditions occur, shut down the engine immediately:

NOTICE

A engine running at full output or with high coolant temperature after a high load operation should idle for five minutes without load. Shutting down without idling may cause damage to the turbocharger.

- The oil pressure swings back and forth or falls sharply.
- Engine power and rpm fall, even though the accelerator pedal remains steady.
- The exhaust pipe gives off heavy smoke.
- The coolant and/or oil temperature climb abnormally.
- Abnormal sounds suddenly occur in the engine or turbocharger.

5.01.11 Emergency Running Mode

The engine is equipped with an electronic motor control system which monitors the engine as it is running.

NOTICE

To prevent possible serious engine damage, have any faults corrected without delay by an authorized service location.

As soon as an engine fault is detected, it is evaluated and one of the following measures is initiated.

- In conjunction with any dashboard or instrument panel display, the code for the electronic control unit reporting the fault can be read immediately on the display.
- If the fault is serious enough to impair normal operation, the electronic control unit switches over to a "limp home" mode. The limp home speed is dependent on engine control parameters and could be as low as 1000 rpm. This allows you to safely move the vehicle to a service location or a safe stopping area.

5.01.12 Stop Engine Override Option

The Stop Engine Override Option is used for a momentary override. The electronic engine control system will record the number of times the override is activated after an engine fault occurs.

Momentary Override

A Stop Engine Override Switch is used to override the shutdown sequence. This override resets the 60 second (30 second for oil pressure) shutdown timer, restoring power to the level when the RSL/Stop Engine was illuminated. The switch must be recycled after five seconds to obtain a subsequent override.

NOTE: The operator has the responsibility to take action to avoid engine damage.



DIAGNOSTIC
REQUEST/STOP
ENGINE
OVERRIDE
SWITCH



AMBER
WARNING
LAMP



RED
STOP
LAMP

47471

5.01.13 Cold Weather Operation

Special precautions must be taken during cold weather. To protect your engine, special cold weather handling is required for fuel, engine oil, coolant, and batteries.

NOTICE

To avoid engine damage, DO NOT use any type of aerosol spray, e.g., ether, starting fluid or brake cleaner to aid in starting the engine.

Winter Fronts

Winter fronts on DD engines are seldom necessary due to the modern design of the engine cooling system. The coolant thermostat is on the inlet side of the cooling system on the DD Platform engine and regulates coolant flow from the radiator into the engine. The thermostat regulates coolant flow to control the temperature of the coolant within the coolant circuit. The following benefits are a result from regulating the coolant at the inlet temperature side of the engine:

- Reduced thermal cycling of the engine
- Operating temperature is reached faster
- Improved vehicle heating because of better temperature regulation

Further information on the thermostat function may be found in the Coolant Thermostat section of the engine workshop manual.

Use of a winter front on a DD Platform engine, particularly those that are fully closed, **will** cause performance issues and is not recommended on DD Platform engines. Winter fronts can result in the following:

- Excessive fan run time due to higher Charge Air Cooler (CAC) outlet temperatures resulting from low air flow through the CAC
- Increased fuel consumption
- Failure of the DEF system heaters to turn on when needed due to incorrect temperature calculations resulting in fault codes, poor performance of the Aftertreatment System, and power reduction
- Failure of critical emission equipment that will result in vehicle speed inducement to a maximum of 5 mph

Use of a winter front should be avoided as this has been shown to cause false fault codes with the engine and aftertreatment system. This has also been linked to specific component failures that will cause vehicle downtime and lost productivity.

There are two specific situations where a winter front may be temporarily needed:

- To improve cab heating while idling under extreme cold ambient temperature
- When the ambient temperature remains below -30°C (-22°F) **and** the engine is unable to maintain running coolant temperature of 80°C (175°F) during normal over-the-road operation

If either of the above situations is encountered, then a winter front may be temporarily used. A minimum of 25% of the grill must be open in sectioned stripes that run perpendicular to the charge air cooler tube flow direction. This assures even cooling across each tube and reduces header-to-tube stress and possible failure.

6.01 DDEC System	46
6.01.01 Motor Control Module Description - EuroV	46
6.01.02 Common Powertrain Controller	48
6.02 Detroit Diesel Electronic Control System Operation.....	49
6.02.01 Stop Engine Override Switch	51
6.02.02 Immediate Speed Reduction	51
6.02.03 Red Stop Lamp.....	51
6.02.04 Diagnostic Tool	51
6.03 Detroit Diesel Electronic Control System Features	52
6.03.01 Data Recording Capability	52
6.03.02 Engine Brake.....	53
6.03.03 Engine Protection	53
6.03.04 Idle Shutdown Timer	54
6.04 Accelerating the Vehicle.....	54
6.05 Cruise Control.....	54
6.06 Engine Brake and Cruise Control.....	57
6.07 DD Platform Shifting	57
6.08 Idling	57

6. Detroit Diesel Electronic Controls (DDEC) System

6.01 DDEC System

All engines for 2010 are equipped with an electronic control system called Detroit Diesel Electronic Control (DDEC). The electronic engine control system regulates the fuel injection quantity and timing using solenoid valves, allowing extremely low-emission operation. Besides the engine and its related sensors, the system has three other control modules:

- Motor Control Module (MCM)
- Common Powertrain Controller (CPC)
- Aftertreatment Control Module (ACM)

The three control units are connected by a proprietary datalink through which all necessary data and information can be exchanged.

The MCM monitors both the engine and the datalink. When a malfunction or other problem is detected, the system selects an appropriate response; for example, the emergency running mode may be activated.

- The MCM processes the data received from the CPC, for example, the position of the accelerator pedal and engine brake.
- This data is evaluated together with the data from the sensors on the engine, such as coolant and fuel temperature and oil and charge pressure. The data is then compared to the characteristic maps or lines stored in the MCM. From this data, quantity and timing of injection are calculated.

The CPC broadcasts all information on datalinks. A certified service center technician can access the CPC via the datalink using the Detroit Diesel Diagnostic Link (DDDL) electronic diagnostic tool.

- The CPC communicates with the MCM unit installed on the vehicle over the proprietary datalink.
- Data for specific applications is stored in the CPC. Examples include idle speed, maximum running speed, and speed limitation.

The CPC receives data from several sources. Examples include:

- Accelerator pedal position, engine brake switch
- Anti-lock brake system and other electronic control units
- Oil pressure, coolant temperature and others, from the MCM

From this data, instructions are computed for controlling the engine and transmitted to the CPC via the proprietary datalink. The ACM monitors the Aftertreatment System (ATS). When a malfunction or other problem is detected, the system selects an appropriate response to deliver to the operator.

6.01.01 Motor Control Module Description - EuroV

The Motor Control Module (MCM) is typically located on the left-hand side of the engine.

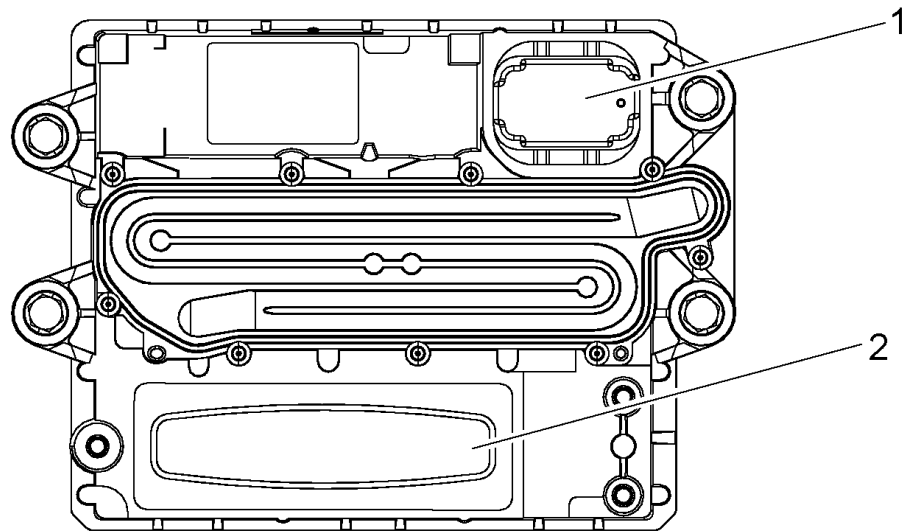

d540073

1. Connector 1

2. Connector 2

Fig 8, Motor Control Module - EuroV

The MCM processes the data received from the Common Powertrain Controller (CPC), for example the position of the Accelerator Pedal (AP), engine brake, etc.

These data are evaluated together with the data from the sensors on the engine, such as coolant and fuel temperature and oil and charge pressure. The data is then compared to the characteristic maps or lines stored in the MCM. From these data, quantity and timing of injection are calculated.

NOTE: To obtain a replacement MCM, all the data given on the MCM label are required.

The MCM data label has the 10 digit engine serial number.

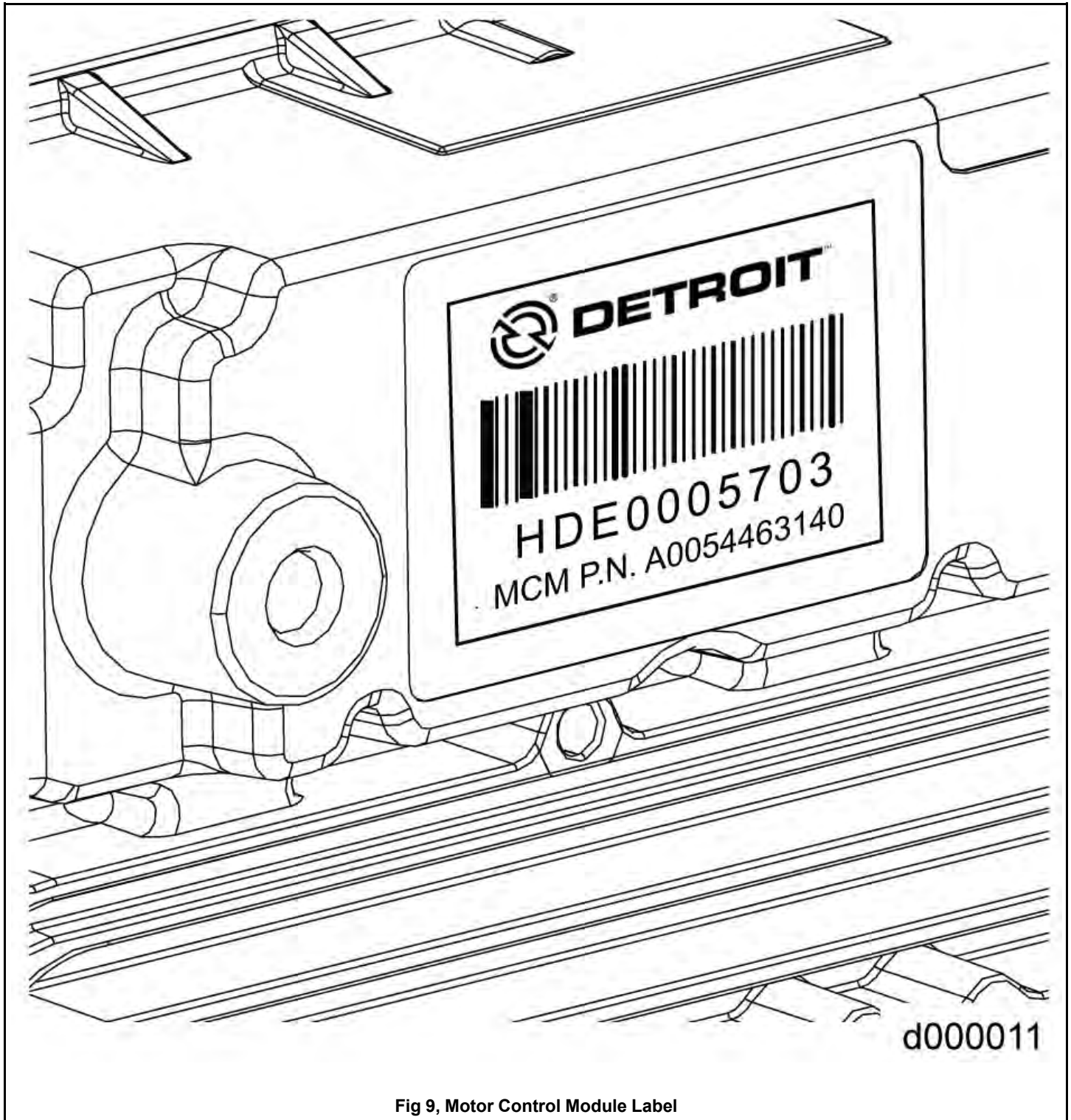

Fig 9, Motor Control Module Label

6.01.02 Common Powertrain Controller

The Common Powertrain Controller (CPC) communicates with any other Motor Control Module (MCM) unit installed on the vehicle over the J1939 data link.

Data for specific applications is stored in the CPC. These include idle speed, maximum running speed, and speed limitation. From these data, instructions are computed for controlling the engine and transmitted to the CPC via the proprietary datalink.

The CPC receives data from the following sources:

- The operator (accelerator pedal position, engine brake switch)
- Other electronic control units (for example, the anti-lock brake system)
- The MCM (oil pressure and coolant temperature)

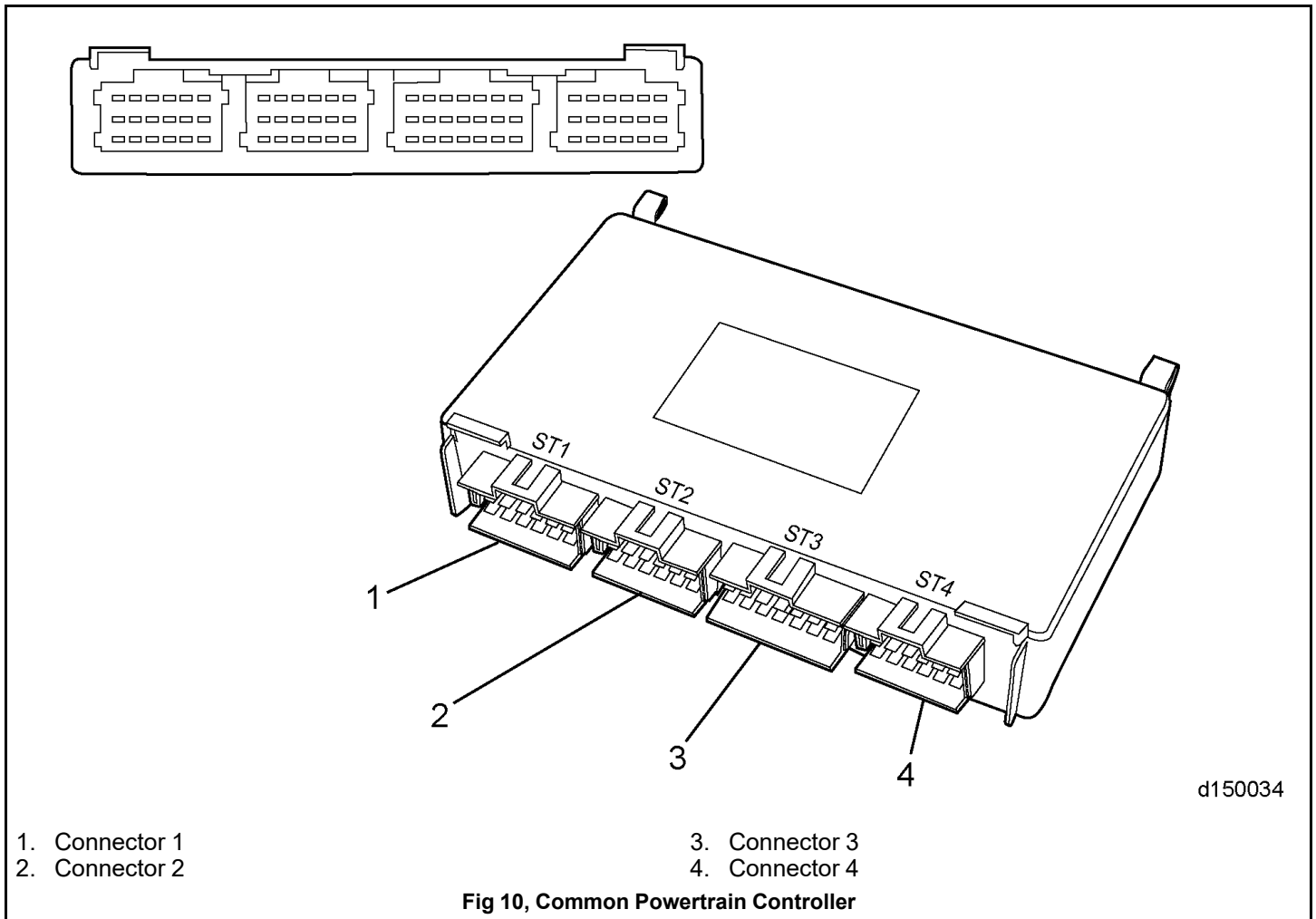

6.02 Detroit Diesel Electronic Control System Operation

NOTE: This engine is equipped with DDEC software. This software generally assures optimal engine performance. The installation of software upgrades may cause minor changes in features and engine performance.

Since the DDEC system is electronic, a battery is required to operate the computer. The system operates at 12 volts. However, in the event of a power supply malfunction, the system will continue to operate at reduced voltage. When this occurs, the AWL (Check Engine) will come on.



DIAGNOSTIC
REQUEST/STOP
ENGINE
OVERRIDE
SWITCH



AMBER
WARNING
LAMP



RED
STOP
LAMP

47471

The engine will only operate at reduced rpm until the battery voltage reaches a point where the MCM will no longer function and the engine shuts down.

Should the AWL (Check Engine) come on for any reason, the vehicle can still be operated and the driver can proceed to the required destination. *This condition should be reported to an authorized Detroit™ distributor or dealer.*

**NOTICE:**

When the RSL (Stop Engine) comes on, the system has detected a major malfunction in the engine that requires immediate attention. **It is the operator's responsibility to shut down the engine to avoid serious damage.**

The engine can be configured to give a warning only, to ramp down (reduce power) or to shut down. Ramp down will reduce engine rpm to a predetermined speed, but will not shut down the engine. With the 30-second shutdown option, the engine will begin a 30-second, stepped power down sequence until it shuts down completely.

The "Stop Engine Override" feature can be activated in the case where the vehicle is operating in a critical location.

6.02.01 Stop Engine Override Switch

This feature allows the operator to override the automatic Stop Engine sequence.

This is done by pressing the Stop Engine Override Switch every 15 to 20 seconds to prevent engine shutdown from occurring.

NOTE: Continuously holding down the Stop Engine Override Switch will not prevent the engine shutdown sequence. You must continue to reset the automatic shutdown system by pressing the Stop Engine Override Switch at intervals of approximately 15 to 20 seconds.

It takes 30 seconds from the time the automatic shutdown sequence begins until engine shutdown. Therefore, the operator **must** press the override switch just prior to engine shutdown and continue to do so until the vehicle can be brought to a stop in a safe location.

6.02.02 Immediate Speed Reduction

The immediate speed reduction option will bring engine rpm back to a predetermined speed, but will not shut down the engine.

The engine should not be restarted after it has been shut down by the engine protection system, unless the problem has been located and corrected.

6.02.03 Red Stop Lamp

The conditions that will cause the RSL (Stop Engine) to come on are:

- High coolant temperature
- Loss of coolant
- High oil temperature
- Low oil pressure
- Auxiliary shutdown

Whenever the AWL (Check Engine) or the RSL comes on, the DDEC 10 system will determine where the problem is and will then store this information in its memory.

If the malfunction is intermittent, the lights will come on and go off as the computer senses the changing engine condition.

6.02.04 Diagnostic Tool

The diagnostic tool for Detroit Diesel Electronic Control (DDEC 10) is the DiagnosticLink® 8.x. DiagnosticLink requirements are listed earlier in the manual under Data Recording Capability.

Once the malfunction has been corrected, the DDEC system will return the engine to normal operation.

The air temperature in the intake system is increased with the addition of EGR. DDEC is programmed to reduce fueling (power) for a short time to reduce air and coolant temperatures when necessary.

DDEC will store an information code when this event occurs, but no corrective action is required. This action is designed to maintain operation without a noticeable effect on vehicle performance.

NOTE: EuroV can be outfitted with an OEM smart dash which does not require driver interaction to display malfunction lamps. Malfunction lamps will display across the information screen if equipped.

6.03 Detroit Diesel Electronic Control System Features

The electronic engine control system offers a variety of features and options designed to warn the operator of any engine or Aftertreatment System (ATS) malfunction. Options can range from warning panel lights to automatic reduction in engine power followed by automatic engine shutdown. **The electronic engine control system has the ability to perform diagnostics for self-checks and continuous monitoring of other system components.**

Depending on the application, the electronic engine control system can monitor oil temperature, coolant temperature, oil pressure, fuel pressure, coolant level and remote sensors (if used).

The electronic engine control system activates the Amber Warning Lamp (AWL) / Check Engine and the Red Stop Lamp (RSL) / Stop Engine to provide a visual warning of a system malfunction.

6.03.01 Data Recording Capability

The electronic engine control system (DDEC 10 and newer) has the ability to extract detailed data on engine use and performance using DDEC Reports software. This detailed data (or DDEC Data) is stored in the CPC and contains information on engine performance such as fuel economy, idle time, and time in top gear. Critical incidents such as detailed diagnostic data records and hard braking events are also stored. DDEC Data can be downloaded using DDEC Reports software to produce reports.

NOTE: As the diagnostic and reprogramming software applications have evolved, the requirements for additional computer storage capacity and memory have increased. Please review these computer specifications carefully and take any necessary steps to update your hardware as needed.

DiagnosticLink®8.0 Minimum System Requirements:

- IT Security Firewall Access for TCP Port 48481
- Windows XP SP2, Windows Vista SP2, Windows 7, Windows 8, 32- and 64-bit (please note: some Access Freightliner applications do not support Windows 8)
- 2.0 GHz Dual-Core processor or greater
- 2 GB RAM or more
- 40 GB hard drive with 20 GB free space
- Monitor and graphics card supporting 1024 x 768 resolution
- 1 free USB port
- High Speed Internet - Broadband Internet
- Nexiq USB-Link with USB cable (required for Cascadia diagnostics)
- Administrative Rights (for installation only)
- **Minimum System Requirements:**
- IT Security Firewall Access for TCP Port 48481
- Windows XP SP2, Windows Vista SP2, Windows 7, Windows 8, 32- and 64-bit (please note: some Access Freightliner applications do not support Windows 8)
- • 2.0 GHz Dual-Core processor or greater
- 2 GB RAM or more
- 40 GB hard drive with 20 GB free space
- Monitor and graphics card supporting 1024 x 768 resolution
- 1 free USB port

- High Speed Internet - Broadband Internet
- Nexiq USB-Link with USB cable (required for Cascadia diagnostics)
- Administrative Rights (for installation only)
- **DiagnosticLink 8.0 Minimum System Requirements:**
- IT Security Firewall Access for TCP Port 48481
- Windows XP SP2, Windows Vista SP2, Windows 7, Windows 8, 32- and 64-bit (please note: some Access Freightliner applications do not support Windows 8)
- 2.0 GHz Dual-Core processor or greater
- 2 GB RAM or more
- 40 GB hard drive with 20 GB free space
- Monitor and graphics card supporting 1024 x 768 resolution
- 1 free USB port
- High Speed Internet - Broadband Internet
- Nexiq USB-Link with USB cable (required for Cascadia diagnostics)
- Administrative Rights (for installation only)

NOTE: DiagnosticLink 8.X is backwards compatible with DDEC VI units.

6.03.02 Engine Brake

The engine brake is enabled by a dash-mounted ON/OFF Switch with a separate intensity switch to select low, medium, or high braking power.



CAUTION:

LOSS OF VEHICLE CONTROL

To avoid injury from loss of vehicle control, do not activate the Engine Brake system under the following conditions:

- On wet or slippery pavement, unless the vehicle is equipped with ABS (anti-lock braking system) and you have had prior experience driving under these conditions.
- When driving without a trailer (bobtailing) or pulling an empty trailer.
- If the tractor drive wheels begin to lock or there is fishtail motion after the Engine Brake is activated, deactivate the brake system immediately if this occurs.

The engine brake will only operate when the Accelerator Pedal is fully released. Disengaging the clutch will prevent the engine brake from operating.

The engine brake will supply braking power even when in Cruise Control. The Motor Control Module will control the amount of engine braking with respect to the Cruise Control set speed. The maximum amount of braking (low, medium, high) is selected with the dash or steering wheel switches.

6.03.03 Engine Protection

The electronic engine control protection system monitors all engine sensors, electronic components, and recognizes system malfunctions. If a critical fault is detected, the AWL (Check Engine) and RSL (Stop Engine) illuminate. The malfunction codes are logged into the MCM's memory.

The standard parameters which are monitored for engine protection are low coolant level, high coolant temperature, low oil pressure, and high oil temperature.

**WARNING:****PERSONAL INJURY**

To avoid injury from engine shutdown in an unsafe situation, ensure the operator knows how to override the stop engine condition on a DDEC-equipped unit.

NOTICE

Engines equipped with the power down/shutdown option have a system override button or switch to allow engine operation for a short period of time. Using the override button so the engine does not shut down in 30 seconds but operates for an extended period may result in engine damage.

This system features a 30-second, stepped-power shutdown sequence, or an immediate speed reduction without shutdown in the event a major engine malfunction occurs, such as low oil pressure, high oil or coolant temperature, or low coolant level.

6.03.04 Idle Shutdown Timer

This feature is an optional 1-80 minute idle shutdown system. Its purpose is to conserve fuel by eliminating excessive idling and allowing a turbocharger cool-down period. To activate the shutdown, the transmission must be in neutral with the vehicle parking brakes set and the engine in idle or fast-idle mode.

6.04 Accelerating the Vehicle

Engine response versus pedal movement may feel different from the mechanical-governed engine you were driving. The Accelerator Pedal (AP) was designed to communicate 'percentage' foot pedal travel to the engine's Motor Control Module (MCM). The engine will respond accordingly to the driver's demand.

Another throttle or governor characteristic you may need time to get used to is the DDEC Limiting Speed Governor. This allows the driver to command total engine response between idle and rated speed, such as accelerating at half throttle - an advantage when driving under slippery conditions.

If you require wide-open throttle engine response, either accelerating or just plain pulling hard, the throttle AP will have to be held to the floor. To obtain 100% fueling at any speed, the AP will have to be maintained at the fully pressed position.

6.05 Cruise Control

For added driver convenience and comfort, DDEC also features a Cruise Control option that works just like the system in your car. It can be operated in any gear above 1100 rpm or road speed faster than 20 mph (32 kph), up to the rated engine speed. It also can be programmed to hold your road speed at or below the maximum vehicle speed. The switch to energize Cruise Control is usually mounted on the instrument panel or steering wheel.

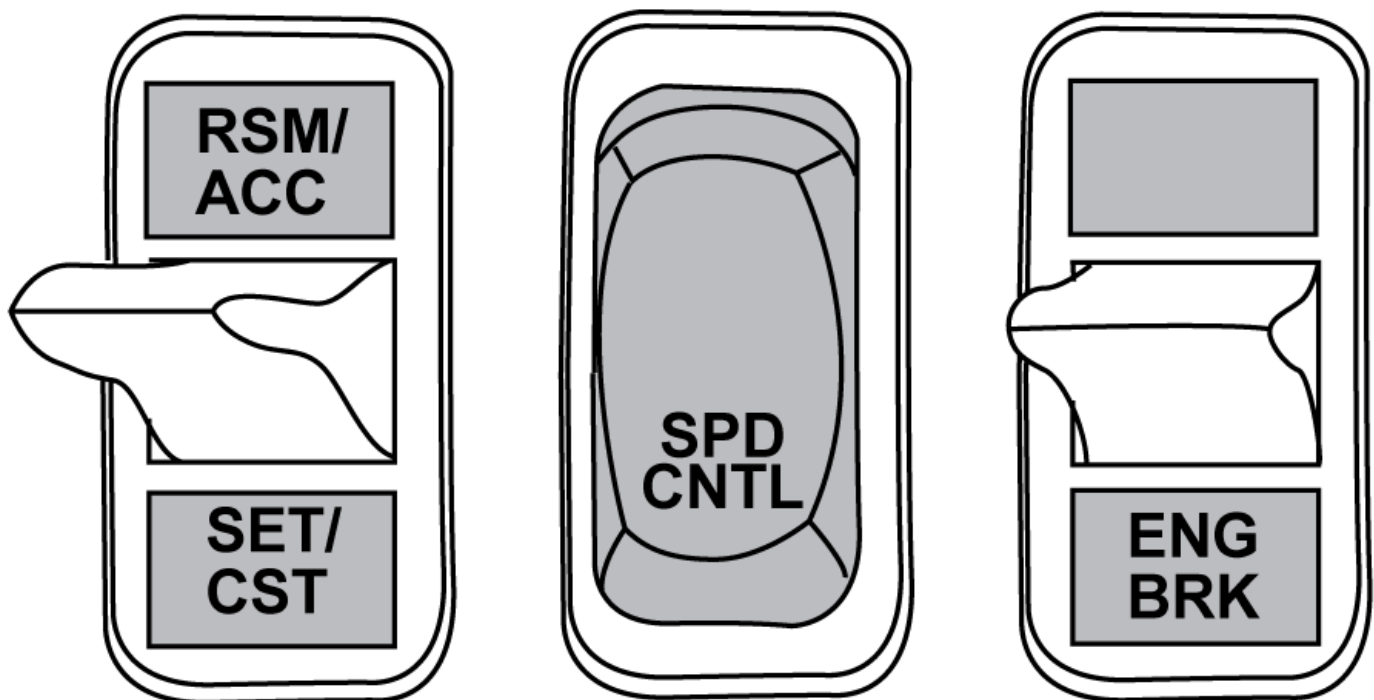

47521

Engine speed and power are varied under Cruise Control to maintain the set vehicle speed. The vehicle speed must be above Min Cruise Set Speed and below Max Cruise Set Speed. It is recommended that Max Cruise Set Speed be set to the default to allow proper operation of other features such as Fuel Economy Incentive and PasSmart. The Vehicle Speed Limit should be used to limit vehicle throttle speed.

Turn the switch ON to energize the system. Remember as a check after each engine start, DDEC looks for a one-time activation of the clutch (if equipped) and service brake before DDEC allows Cruise Control to be enabled.

DDEC must also see or recognize that the Cruise Enable Switch has changed. If the Cruise Enable Switch is OFF it needs to be turned ON. If the Cruise Enable Switch is left in the ON position at key OFF, the switch must be cycled OFF then ON

for DDEC to see a status change to allow Cruise Control activation. The status of DDEC inputs to activate Cruise Control at key ON is listed in the following table.

Input	Input Status at Key ON	Input Status Before Cruise Control Activates
Service Brake Switch	ON	OFF
Clutch Release Switch (Manual Trans. only)	ON	OFF
Cruise Control Enable Switch	OFF	ON

Once Cruise Control is enabled and you reach your road speed, press the SET Switch to activate Cruise Control. The cruise light will come on. To increase road speed toggling the switch will result in a one mile-per-hour (1.6 kph) increase or decrease in vehicle speed. If Cruise Control has been disabled, toggling the RSM/ACC Switch restores the vehicle to the previously set cruise speed. , press the RSM/ACC Switch. To reduce road speed, press and hold the SET/CST Switch until the lower speed is reached.

Cruise Control can be overridden at any time with the throttle pedal if the vehicle is operating at less than the programmed Max Road Speed.

Cruise Control is deactivated by slightly pressing the service brakes, clutch pedal, or trailer brake. The ON/OFF Switch will also deactivate Cruise Control.

Cruise Control will maintain vehicle speed even on upgrades, unless power requirements demand a downshift. If the Cruise Control/Engine Brake function is turned ON, the Cruise Control will limit your speed on downgrades. Most likely, Cruise Control will feel stronger than driving with the accelerator pedal because of the instantaneous and wide-open throttle response. That's why Cruise Control use is not suggested during slippery driving conditions.

Use Cruise Control after downshifting on a hill to pull the hill. Hitting the RSM/ACC Switch (not the SET Switch) will keep the truck accelerating in the lower gears up to the rated engine speed.



CAUTION:

LOSS OF VEHICLE CONTROL

To avoid injury from the loss of vehicle control, do not use cruise control under these conditions:

- When it is not possible to keep the vehicle at a constant speed (on winding roads, in heavy traffic, in traffic that varies in speed, etc.).
- On slippery roads (wet pavement, ice-or snow-covered roads, loose gravel, etc.).

Cruise Control will maintain the set speed under normal road and load conditions. It cannot limit vehicle speeds on down grades if available engine braking effort is exceeded, nor can it maintain speed on upgrades if power requirements exceed engine power capability.

Cruise Control will disengage below 1000 rpm or 20 mph (32 kph) road speed. When using Cruise Control, if you want to pull the engine below 1000 rpm, remember to hold the accelerator pedal to the floor to keep the engine pulling at wide-open throttle. The engine will pull down to about 1050 rpm.

Remember: The electronic data programmed into the DDEC system will not allow you to hurt or over fuel the engine at low or lug engine speeds. There is enough oil pressure to withstand hard pulls at low engine speeds.

Cruise Control may also be programmed to permit fast idle using the Cruise Control switches.

With the engine at normal idle, transmission in neutral and service brakes on, press the SPD CNTL Switch, and use the RSM/ACC Switch. The engine rpm should increase to a pre-defined speed. The engine rpm can be raised or lowered from this point using the SET/CST and RSM/ACC switches.

6.06 Engine Brake and Cruise Control

Your engine is equipped with both Cruise Control and an engine brake; the engine brake can operate automatically while you are in Cruise Control. If the Cruise Control/Engine Brake function is turned ON in the DDEC system programming, the engine brake will come on low when your set road speed increases a few mph (kph) above your cruise set speed. If your speed continues to increase, the DDEC system will increase the engine brake's braking power progressively. When the vehicle returns to the set cruise speed the engine brake will turn off until you need them.

For safety reasons, don't use Cruise Control when it is not possible to keep the vehicle at constant speed due to:

- Winding roads
- Heavy traffic
- Slippery pavement
- Descending grades calling for engine brake assistance

For an explanation of the engine brake system and recommendations for proper operation, "Engine Brake System" in this manual.

6.07 DD Platform Shifting

Depending on your transmission model, the gear split may vary from 400 to 500 rpm. The electronic governor provides almost no overrun capability; and, if the transmission is downshifted too early, you will experience a temporary loss of pulling power until the engine speed falls below rated speed.

In general, when using a 7- or 9-speed transmission, you should always downshift between 1150 and 1250 rpm for the DD13 and between 1000 and 1100 rpm for the DD15 and DD16. This is true even on steep grades with heavy loads. When using an 18-, 15-, or 13-speed transmission, you will need to downshift at an rpm that allows "less than rated" rpm before throttle application in the next gear down. You may want to limit engine speed to 1900 rpm in all gears. DD Platform engines provide horsepower through 2100 rpm, but fuel economy is not as efficient above 1800 rpm.

If you decide to drive at a lower rpm for improved fuel economy, don't let different engine noises throw you off guard. The engine sounds quiet at 1400 rpm, almost as if it had quit pulling. Depending on the air intake arrangement, you may also experience a "chuffing" sound as the engine starts to pull hard at lower rpm. This is normal and caused by the velocity changes of the air flow within the air intake plumbing. Electronic engines can actually deliver more fuel at lower engine speeds than at rated speed.

The engine has been designed for a very quiet operation, but the air flow may be noticeable to the tuned, attentive ear. The turbocharger operates at higher boost pressure forcing EGR gas flow through the EGR plumbing. In some situations the driver may believe he/she has experienced a charge air cooler system leak. Even connecting trailer light and air hoses, the driver may hear a different tone (exhaust and under hood with the engine idling.) If equipped with a turbo boost gauge, the driver may occasionally note intake manifold pressure exceeds 35 psi (6.89 kPa).

6.08 Idling

The common belief that idling a diesel engine causes no engine damage is wrong. Idling produces sulfuric acid, which is absorbed by the lubricating oil and eats into bearings, rings, valve stems and engine surfaces. If you must idle the engine for cab heat or cooling, the high idle function of the Cruise Control switches should be used. An idle speed of 900 rpm should be enough to provide cab heat in above 0°C (32°F) temperatures.

7.01 Engine Brake System	60
7.01.01 Driver Control Switches	60
7.01.02 Clutch Pedal and Throttle Position Controls	60
7.01.03 Engine Brake Activation Conditions	60
7.01.04 Engine Brake Operation	60
7.01.05 Anti-Lock Braking Systems	61
7.01.06 Operating on Flat, Dry Pavement	61
7.01.07 Operating Down a Long, Steep Grade	61
7.01.08 Operating on Wet or Slippery Pavement	62

7. Engine Brake System

7.01 Engine Brake System

The engine is equipped with an engine brake. Before operating the vehicle, you must familiarize yourself with the engine brake system to obtain optimum benefit from it. Engine brake control systems may vary slightly, depending on the engine brake configuration and cab design. However, basic operator controls are similar for all models.

7.01.01 Driver Control Switches

Vehicles with manual transmissions allow the driver to turn the engine brake on and off and select a Low, Medium, or High level of braking.

- The "Low" setting on this switch activates braking on two cylinders, yielding about one-third engine braking horsepower.
- The "Medium" setting on this switch activates four cylinders, supplying about two-thirds engine braking horsepower.
- The "High" setting on this switch activates all six cylinders, providing full engine brake horsepower.

NOTE: There is very little difference in the exhaust sound when the engine brakes are activated in either the medium or high position.

7.01.02 Clutch Pedal and Throttle Position Controls

Engine brakes have two additional controls, one activated by the position of the clutch pedal and the other activated by the position of the throttle. These controls permit fully automatic operation of the engine braking system.

7.01.03 Engine Brake Activation Conditions

The engine braking system only permits fully automatic operation when the following conditions are met:

- Engine Brake switch is on.
- An Engine Brake level (Low/Med/High) is selected.
- Vehicle meets the programmed minimum speed.
- The Clutch Pedal is out.
- The Accelerator Pedal is at zero percent activation.

7.01.04 Engine Brake Operation

NOTICE

Always allow the engine to reach full normal operating temperature before activating the engine brake system to ensure positive engine brake engagement.

The engine brake system depends on a full-pressure flow of warm engine lubricating oil for proper lubrication of moving parts and optimum performance.

The minimum operating speed for the engine brake is 900 rpm. A check engine lamp will be illuminated when the operating speed exceeds 2200 to 2300 rpm depending on engine configuration.

NOTICE

Never exceed 2500 rpm or extensive engine damage can occur.

**CAUTION:****LOSS OF VEHICLE CONTROL**

To avoid injury from loss of vehicle control, do not activate the Engine Brake system under the following conditions:

- On wet or slippery pavement, unless the vehicle is equipped with ABS (anti-lock braking system) and you have had prior experience driving under these conditions.
- When driving without a trailer (bobtailing) or pulling an empty trailer.
- If the tractor drive wheels begin to lock or there is fishtail motion after the Engine Brake is activated, deactivate the brake system immediately if this occurs.

Under normal driving conditions the engine brake system is left in the ON position. However, this should change if roads become wet or slippery.

NOTICE

Do not attempt to “double clutch” the transmission while the engine brake system is turned on. Shifting gears without pressing the clutch or using the engine brake to reduce engine rpm may result in serious powertrain damage.

After it is switched on, the engine brake system is automatically activated each time you remove your feet completely from the clutch pedal and accelerator pedal. The engine brake automatically deactivates itself when you press the clutch pedal while shifting gears.

NOTE: Some systems may be programmed to activate themselves only when the brake pedal is pressed, so read your vehicle owner's manual thoroughly to find out if you have this option.

7.01.05 Anti-Lock Braking Systems

Vehicles equipped with ABS have the ability to turn the engine brake OFF if a wheel-slip condition is detected. The engine brake will automatically turn itself ON once the wheel slip is no longer detected.

The DDEC system will deactivate the engine brake system when the engine speed falls below a preset rpm or when the vehicle slows down to a preset speed, depending on DDEC programming. This prevents stalling the engine. The engine brake can also be used with vehicle Cruise Control turned ON.

7.01.06 Operating on Flat, Dry Pavement

Use the following guidelines when driving on flat, dry pavement:

- If driving on flat, dry, open stretches with a light load and greater slowing power is not required, place the progressive braking switch in the LOW position.
- If you find you are still using the service brakes, move the progressive braking switch to a higher position until you do not need to use the service brakes to slow the vehicle down.
- If you are carrying a heavier load and road traction is good, move the progressive braking switch to the HIGH position.
- Check your progressive braking switch often for proper position, since road conditions can change quickly. *Never skip a step when operating the progressive braking switch.* Always go from OFF to LOW, and then to a higher position.

7.01.07 Operating Down a Long, Steep Grade

An explanation of speed; may be helpful in understanding how to use the engine brake system while descending a grade. *Control Speed* is the constant speed at which the forces pushing the vehicle forward on a grade are equal to the forces holding it back, without using the vehicle service brakes. In other words, *this is the speed the vehicle will maintain without using the service brakes or fueling.*

NOTICE

Failure to keep the vehicle within safe control speed limits while descending a grade may result in vehicle or property damage or both.

Use the following guidelines when descending a long, steep grade:

1. Before beginning the descent, determine if your engine brake system is operating properly by lifting your foot briefly off the accelerator pedal. You should feel the system activate.
2. Ensure the progressive braking switch is in the appropriate power position (LOW/MED/HIGH).



CAUTION:

BRAKE FADE

To avoid injury, do not over apply the vehicle service brakes when descending a long, steep grade. Excessive use of the vehicle brakes will cause them to heat up, reducing their stopping ability. This condition, referred to as “brake fade”, may result in loss of braking, which could lead to personal injury or vehicle/property damage or both.

3. Do not exceed the safe control speed of your vehicle. Example: You could descend a 6% grade, under control only at 10 mph (16 kph) without an engine brake, but at 25 mph (40 kph) with an engine brake. You could not descend that same hill at 50 mph (80 kph) and still expect to remain under control. Get to know how much slowing power your engine brake can provide. So get to know your engine brake system before climbing hills and do not exceed a safe control speed.



WARNING:

PERSONAL INJURY

Failure to keep the vehicle within safe control speed limits while descending a grade may result in loss of vehicle control, which could cause personal injury.

4. Check your progressive braking switch often for proper position (LOW/MED/HIGH), since road conditions can change quickly. Never skip a step when operating the progressive braking switch. Always go from OFF to LOW and then to a higher position when on slippery roads.

7.01.08 Operating on Wet or Slippery Pavement

Operate the engine brake system as follows:

NOTE: Experience with the engine brake system on dry pavement is recommended before attempting to use it on wet or slippery roads.

1. On wet or slippery pavement, start with the master switch in the OFF position and use the gear you would normally use under these conditions.
- 2.



CAUTION:

LOSS OF VEHICLE CONTROL

To avoid injury from loss of vehicle control, do not activate the Engine Brake system under the following conditions:

- On wet or slippery pavement, unless the vehicle is equipped with ABS (anti-lock braking system) and you have had prior experience driving under these conditions.
- When driving without a trailer (bobtailing) or pulling an empty trailer.
- If the tractor drive wheels begin to lock or there is fishtail motion after the Engine Brake is activated, deactivate the brake system immediately if this occurs.

NOTE: On single trailers or combinations, a light air application of the trailer brakes may be desirable to help keep the trailer stretched out. Follow the manufacturer's recommended operating procedure when using your trailer brakes.

If the vehicle is maintaining traction, place the selective braking switch in the LOW position and turn ON the engine brake system. If the drive wheels are maintaining traction and you desire greater slowing power, move the braking switch to the next highest position.

3. However, if the tractor drive wheels begin to lock or there is a fishtail motion, turn the engine brake system OFF immediately and do not activate it until road conditions improve.
4. Check your progressive braking switch often for proper position (LOW/MED/HIGH), since road conditions can change quickly. Never skip a step when operating the progressive braking system. Always go from OFF to LOW and then to a higher position.

8.01 Engine Systems66

8. Engine Systems

8.01 Engine Systems

The engine systems are as follows:

Two-Filter Fuel System

The two-filter fuel system consists of DDEC control system, fuel injectors, low and high pressure pumps, fuel filter module, prefilter, coalescer/final filter, and the necessary connecting fuel lines. The common rail system with injectors provides amplification for better fuel atomization.

Lubrication System

The lubrication system consists of an oil pump, oil cooler, cartridge-style oil filter, pressure regulator valve, and oil pressure sensor. Clean, pressurized oil is fed to all components via passages in the engine block and cylinder head.

Air System

Outside air enters the engine through the air filter and is drawn to the turbocharger and then is compressed, and forced through the air-to-air charge cooler (heat exchanger) and is cooled. Next, it flows to the intake manifold and into the cylinders, where it mixes with atomized fuel from the injectors.

For optimum engine protection from dust and other airborne contaminants, service the dry-type air cleaners used when the maximum allowable air restriction has been reached.

Cooling System

A radiator/thermo-modulated fan cooling system is used on the engine. This system has a centrifugal-type coolant pump to circulate coolant within the engine. One full-blocking type thermostat located in the coolant module attached to the left side of the cylinder block controls the flow of coolant.

Electrical System

The electrical system consists of a starting motor, starting switch, battery-charging alternator, storage batteries, and necessary wiring.

Exhaust System

Hot exhaust gas from the exhaust manifolds is used to drive the turbocharger.

Exhaust Gas Recirculation System

The Exhaust Gas Recirculation (EGR) system consists of an EGR cooler, EGR valve and actuator. The EGR actuator opens and closes the EGR valve to allow hot exhaust gas to enter the EGR cooler. Heat is extracted from the exhaust gas, resulting in cooler exhaust gas to the cylinders. EGR lowers the temperature of the exhaust from the engine, therefore, reducing exhaust gas emissions to acceptable levels.

The purpose of the Exhaust Gas Recirculation System (EGR) is to reduce engine exhaust gas emissions.

The EGR system has been optimized to dramatically cut NOx formation by routing a measured amount of exhaust flow to the cylinders to lower combustion temperatures. Lower temperatures result in lower NOx levels without the negative effects of retarding engine timing. The EGR valve has been moved to the top of the engine for improved serviceability.

On the 260 - 350 horsepower engines, the EGR is fed by all six cylinders. The low horsepower engines use an asymmetric turbocharger with two entries, and the EGR is fed from the first three cylinders, taken from a small entry. The exhaust with a maximum exhaust gas temperature of 730°C (1346°F) is cooled to a maximum of 150°C (302°F) in the EGR cooler. The cooled exhaust gases then pass through the EGR valve and added to the mixer housing. The addition of cooled exhaust gases back into the combustion airflow reduces the peak cylinder combustion temperature. Less oxides of nitrogen (NOx) are produced at lower combustion temperatures.

9.01 EuroV Aftertreatment System	68
9.02 Diesel Exhaust Fluid Information	69
9.03 Diesel Exhaust Fluid Tank	70
9.04 Aftertreatment Maintenance	70

9. Aftertreatment System

9.01 EuroV Aftertreatment System

The Selective Catalytic Reduction (SCR) catalyst converts a mixture of nitrogen oxides and Diesel Exhaust Fluid (DEF) into nitrogen and water. DEF is pressurized by a pump and is then sprayed into the SCR catalysts within the mixing chamber..

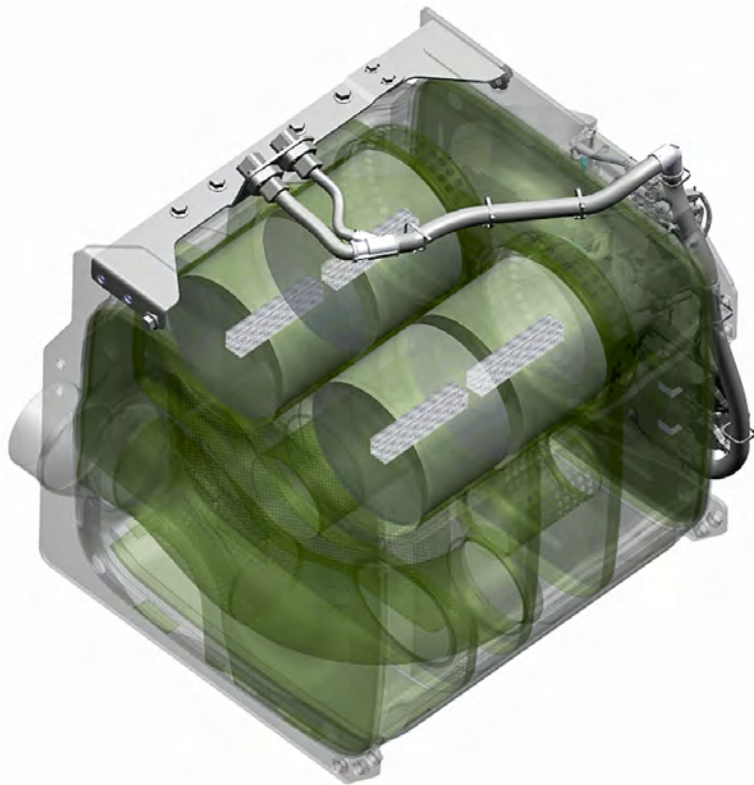

d140916

Fig 11, EuroV Aftertreatment System

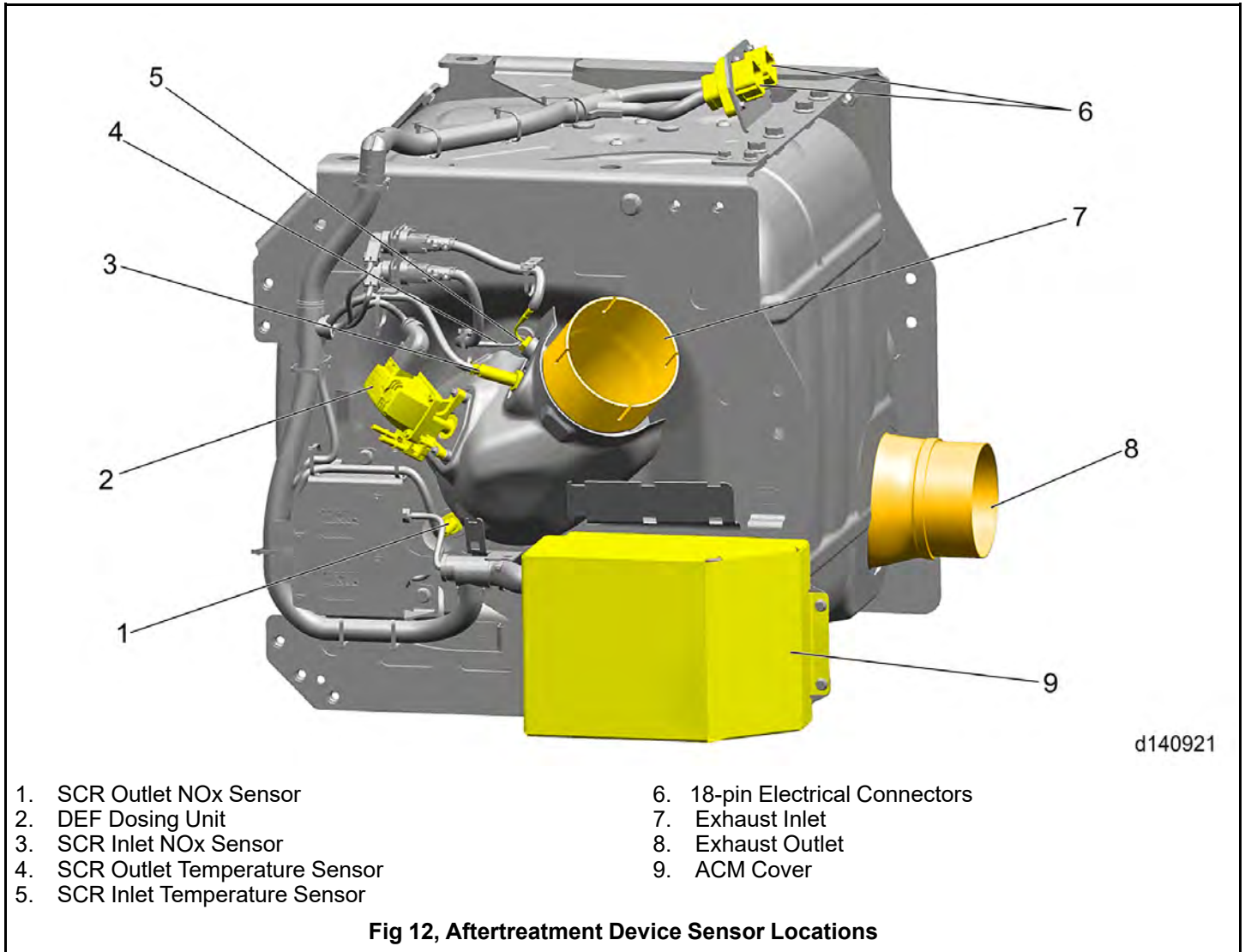

9.02 Diesel Exhaust Fluid Information

The Selective Catalytic Reduction (SCR) aftertreatment system for this engine requires Diesel Exhaust Fluid (DEF) to maintain exhaust emissions at levels compliant with emissions standards. DEF is a simple, non-toxic and inexpensive pre-mixed fluid composed of 2/3 pure water and 1/3 automotive grade urea. The following sections provide information regarding DEF availability, specifications, handling and storage, and certain SCR anti-tampering features.

Diesel Exhaust Fluid Availability

DEF is available in bulk quantities at roadside truck stop service centers. DEF is also available in various container sizes at Detroit™ service outlets, truck dealerships, and many truck service centers. DEF is available in container sizes as small as 2.5 gallons for convenient storage in your vehicle for emergency use.

Diesel Exhaust Fluid Specifications

DEF is manufactured to strict quality standards to ensure proper emissions control. Only DEF that meets DIN70700 or ISO 22241-1 specifications can be used. The American Petroleum Institute has developed a quality certification program to ensure the quality of DEF available at service outlets.

Diesel Exhaust Fluid Handling and Storage

When stored at temperatures between 10° and 90° F (minus 12° and 32° C), DEF has a maximum shelf life of 12 months. For best shelf life it is recommended that Diesel Exhaust Fluid (DEF) containers be stored in a controlled environment.

Diesel Exhaust Fluid System Anti-Tampering Feature

The diagnostic system monitors for faults in DEF system components and monitors the DEF supply pressure. If the diagnostics detect that components critical to the Selective Catalytic Reduction (SCR Catalyst) or DEF supply system are disconnected (which could indicate tampering), or if the diagnostics detect abnormal system pressures indicative of DEF supply blockage, the warning lamp will illuminate and the control system will initiate time and mileage counters. If the sensors detect that the SCR system has been tampered with, the MIL illuminates to warn the driver, and the engine performance is limited, with a 55 mph (90 km/h) speed limit. If the system fault is not corrected, the STOP engine light illuminates and a 5 mph (8 km/h) speed limit will be applied during non-driving conditions. Similar warnings and penalties will result when insufficient urea quantity is present.

9.03 Diesel Exhaust Fluid Tank

The Diesel Exhaust Fluid (DEF) tank holds the DEF supply. The filler neck has a smaller diameter (19 mm) than the filler neck of the diesel fuel tank and is fitted with a magnetic insert so that diesel fuel cannot be mistakenly added to the DEF tank. The DEF you should use with your Detroit™ product will be API (American Petroleum Institute) certified and meet the specifications ISO 22241-1 and DIN70700. These are two widely accepted standards in use for qualifying DEF for use in exhaust aftertreatment systems.

If diesel fuel is added to the DEF tank or DEF is added to the diesel fuel tank, immediately contact your Certified Detroit™ Service Center for further instructions.

9.04 Aftertreatment Maintenance

A high amount of black smoke emitting from the vehicle or illumination of the Amber Warning Lamp or Red Stop Lamp are indications of a system problem. Should this occur, consult your local Detroit™ Service Center.

Illumination of the Malfunction Indicator Lamp (MIL) Lamp indicates a failure of an emissions control device. Call for service to repair the fault.

10.01 Instrument Panel Lamps 72

10. Instrument Panel Lamps

10.01 Instrument Panel Lamps

The instrument panel lamps are explained below:

Amber Warning Lamp

Lamp	Lamp Name	Description	Result
	Amber Warning Lamp (AWL)	Indicates a fault with the engine controls.	Vehicle can be driven to end of shift. Call for service.
Lamp Solid		Lamp Flashing	
<ul style="list-style-type: none"> At the start of every ignition cycle (bulb check). 		<ul style="list-style-type: none"> Flashes last 90 seconds before idle shutdown if programmed for override. 	
<ul style="list-style-type: none"> When an electronic system fault occurs. (Fault should be diagnosed as soon as possible.) 		<ul style="list-style-type: none"> Flashes when idle shutdown or the optimized idle shutdown occurs. 	

Red Stop Lamp

Lamp	Lamp Name	Description	Result
	Red Stop Lamp (RSL)	Indicates a major engine fault that may result in engine damage. Engine derate and/or shutdown sequence will be initiated.	Move the vehicle to the nearest safe location and shut down the engine. Call for service.
Lamp Solid		Lamp Flashing	
<ul style="list-style-type: none"> At the start of every ignition cycle (bulb check). 		<ul style="list-style-type: none"> Flashes when engine protection shutdown occurs. 	
<ul style="list-style-type: none"> A potential engine damaging fault is detected. 			

Malfunction Indicator Lamp

Lamp	Lamp Name	Description	Result
	Malfunction Indicator Lamp (MIL)	Yellow lamp Indicates a failure of an Emission Control device. May illuminate at the same time as the Amber Warning Lamp.	Vehicle can be driven to end of the shift. Call for service.
Lamp Solid		Lamp Flashing	

Lamp	Lamp Name	Description	Result
<ul style="list-style-type: none"> At the start of every ignition cycle (a bulb check). 		<ul style="list-style-type: none"> Never flashes. 	
<ul style="list-style-type: none"> For any emission related fault (light out when the fault is inactive). 			

Fuel Filter Restriction Sensor Lamp: Fuel Filter Failed

Lamp	Lamp Name	Description	Result
	Fuel Filter Restriction Sensor (FFRS) Lamp	Yellow lamp Indicates that the fuel filter is restricted and needs to be serviced. May illuminate at the same time as the Malfunction Indicator Lamp (MIL) and Amber Warning Lamp (AWL).	Service soon.
Lamp Solid		Lamp Flashing	
<ul style="list-style-type: none"> At the start of every ignition cycle (a bulb check). 		<ul style="list-style-type: none"> Never flashes. 	
<ul style="list-style-type: none"> Fuel filter needs service. 			

Water-in-Fuel Lamp (WIF)

Lamp	Lamp Name	Description	Result
	Water-In-Fuel (WIF) Lamp	Yellow lamp indicates that the fuel water separator has reached its capacity and needs to be drained.	Engine water separator must be drained or an engine derate will occur.
Lamp Solid		Lamp Flashing	
<ul style="list-style-type: none"> At the start of every ignition cycle (a bulb check). 		<ul style="list-style-type: none"> Never flashes. 	
<ul style="list-style-type: none"> Water separator has reached it maximum capacity. 			

11.01 Diesel Exhaust Fluid Level Warning Lamps 76

11. EPA10 Diesel Exhaust Fluid Level Warnings Lamps

11.01 Diesel Exhaust Fluid Level Warning Lamps

A four light bar segment indicates the Diesel Exhaust Fluid (DEF) level in 25% increments. Low DEF levels will trigger a decrease in the engine's performance. The use of improper DEF fluid will trigger a decrease in the engine's performance. In an empty or an ignored state and the diesel fuel tank is filled without filling the DEF tank, the vehicle's speed will be limited to 5 mph until DEF is detected in the DEF tank.



**DIESEL EXHAUST FLUID (DEF)
INDICATOR LAMPS**



- The light bar indicates the level of fluid in the DEF tank.
- Low DEF levels will trigger a decrease in engine performance.
- The use of improper fluid will trigger a decrease in engine performance.
- In the empty and ignored state, vehicle speed will be limited to 5 mph until DEF is detected in the tank.



ULTRA LOW SULFUR DIESEL FUEL ONLY

Low DEF warning light

Light bar shows DEF level

DEF level is very low	
DEF level is EMPTY	
DEF level is EMPTY and IGNORED	

Vehicle speed limited to 55 mph / engine derated

Vehicle speed limited to 5 mph / engine derated

DDC-SVC-0TH-0E30 2012. Specifications are subject to change without notice. Detroit and the Spinning Arrow design are registered trademarks of the Detroit Diesel Corporation. Copyright © 2012, Detroit Diesel Corporation. All rights reserved. Detroit Diesel is a Daimler company.



d140339

Fig 13, Driver Card

12.01 Preventive Maintenance Intervals 78

12.02 EuroV Maintenance Tables - 93K222(CK-4) and 93K223(FA-4) 82

12. Preventive Maintenance Intervals

12.01 Preventive Maintenance Intervals

The following guide establishes preventive maintenance intervals. These recommendations should be followed as closely as possible to obtain long life and optimum performance from your engine. When performed on a regular basis, changing the engine oil, coolant, and filters is the least costly way of obtaining safe and reliable vehicle operation. Added benefits and savings occur when you check that the valves, fuel injectors, oil and cooling circuits are in good working order during oil changes.

The intervals shown apply only to the maintenance functions described. These functions should be coordinated with other regularly scheduled maintenance.

Schedule Use

Complete each maintenance operation at the required interval. The intervals are based on a collaboration of field and fleet data. For a more accurate analysis of when fluids should be changed, such as engine oil, refer to publication Engine Requirements; Lubricating Oil, Fuel and Filters and publication Coolant Selections for Detroit™ Engines, available from authorized Detroit™ distributors.

Each maintenance table shows which maintenance operation must be performed at the recommended interval (in miles, kilometers, and hours).

NOTE: Failure to check and maintain Supplemental Coolant Additive levels at required concentrations will result in severe damage (corrosion) to the engine cooling system and related components. Coolant must be inhibited with the recommended Supplemental Coolant Additives listed in this manual.

Cooling System Flush and Fill

Coolant Flush and Fill - Proper maintenance of the cooling system is vital to its performance and longevity. The cooling system must, on a constant basis, deal with cavitation, temperature / pressure swings, and continuous threats on the additive package. Once the additives have been depleted from the coolant, it will only be a matter of time until the engine components suffer. [Cooling System Fill Procedure](#)

Cooling System Inspection - Inspect the cooling system as follows:



WARNING:

HOT COOLANT

To avoid scalding from the expulsion of hot coolant, never remove the cooling system pressure cap while the engine is at operating temperature. Wear adequate protective clothing (face shield, rubber gloves, apron, and boots). Remove the cap slowly to relieve pressure.

1. Inspect the radiator, condenser, coolant pump, engine oil cooler, freeze plugs, and heat exchanger for damage and leaks.
2. Check all cooling system pipes and hoses for damage and leaks; ensure they are positioned to avoid chafing, and are securely fastened.
3. Check the outside of the radiator and condenser for blockage. Check fins for damage; straighten them if necessary.

Valve Lash Checking and Adjustment

Valve lash checking and adjustment should be performed per the maintenance intervals prescribed under the proper service category for the engine. All three service categories (Severe, Short Haul, and Long Haul) require a 'first time' valve lash adjustment at a shorter interval. After the initial adjustment, all others are based on the same mileage intervals. Proper valve lash clearance allows the engine to produce the best possible performance with the lowest emissions. Valve lash adjustments should be performed by an authorized Detroit™ maintenance or repair facility.

Drive Belt

Belts should be neither too tight nor too loose. Belts that are too tight impose extra loads on the crankshaft, fan and/or alternator bearings, shortening both belt and bearing life. Excessively overtightened belts can result in crankshaft breakage. A loose belt will slip and generate excessive heat that may cause damage to the belt and accessory drive components.

**WARNING:*****PERSONAL INJURY***

To avoid injury from rotating belts and fans, do not remove and discard safety guards.

Belt Replacement - Refer to the maintenance tables for when drive belts should be inspected and replaced.

After an extended time in service, minor rib cracks may appear, usually one or two cracks per inch is considered normal. A concern occurs when the belt ribs exhibit severe multiple cracking or 'chunking'. At this point, the belt should be replaced.

Poly-V Belt

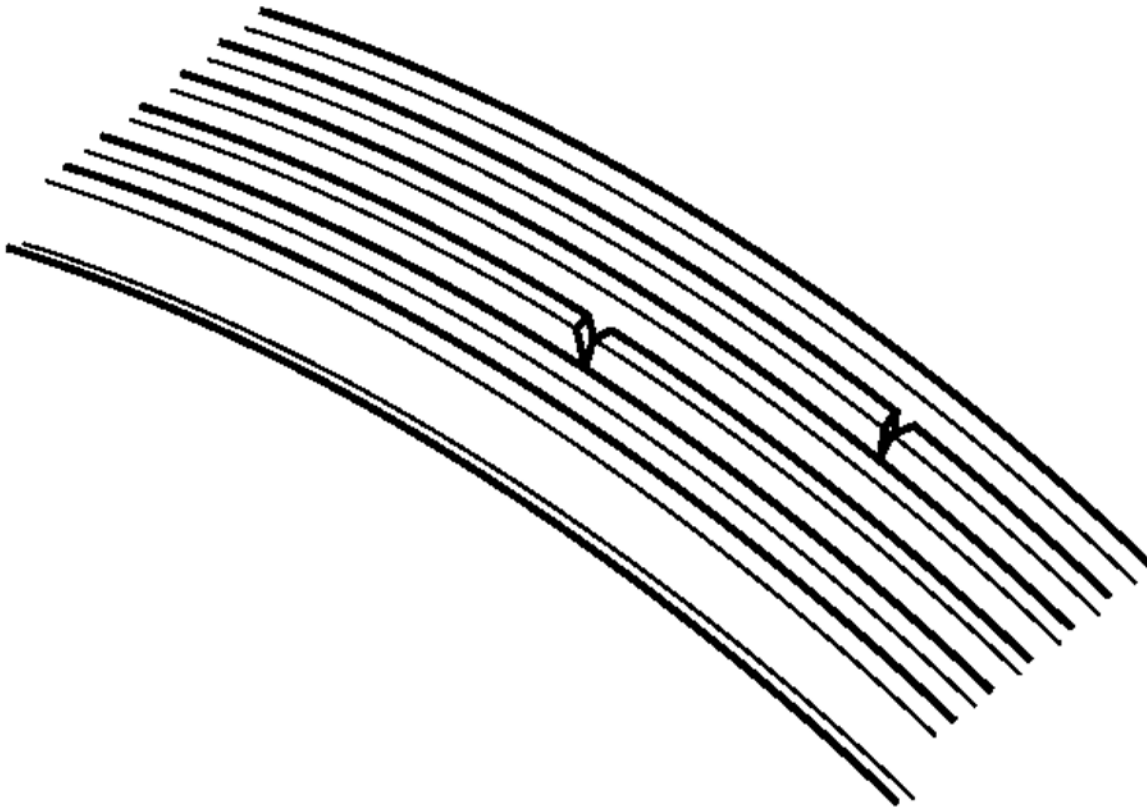

47676

Auto Tensioner - Auto tensioners are usually maintenance free for the life of the engine. However, routine inspections should be performed. Uneven belt wear can indicate a loose, wore out, or bad bearing on the auto tensioner. A build up of dirt or grime around the front bearing surface of the wheel can indicate a future bearing failure due to inadequate lubrication.

Fuel / Water Separator

Incorporated into the fuel filter module is a fuel/water separator. The separator removes emulsified water as well as droplets and is located in the lower compartment of the fuel filter module. A water-in-fuel (WIF) sensor indicates when trapped water needs to be drained.

NOTICE

Do not over-tighten the water drain valve. Failure to properly tighten the water drain valve may cause damage to the water drain valve and housing.

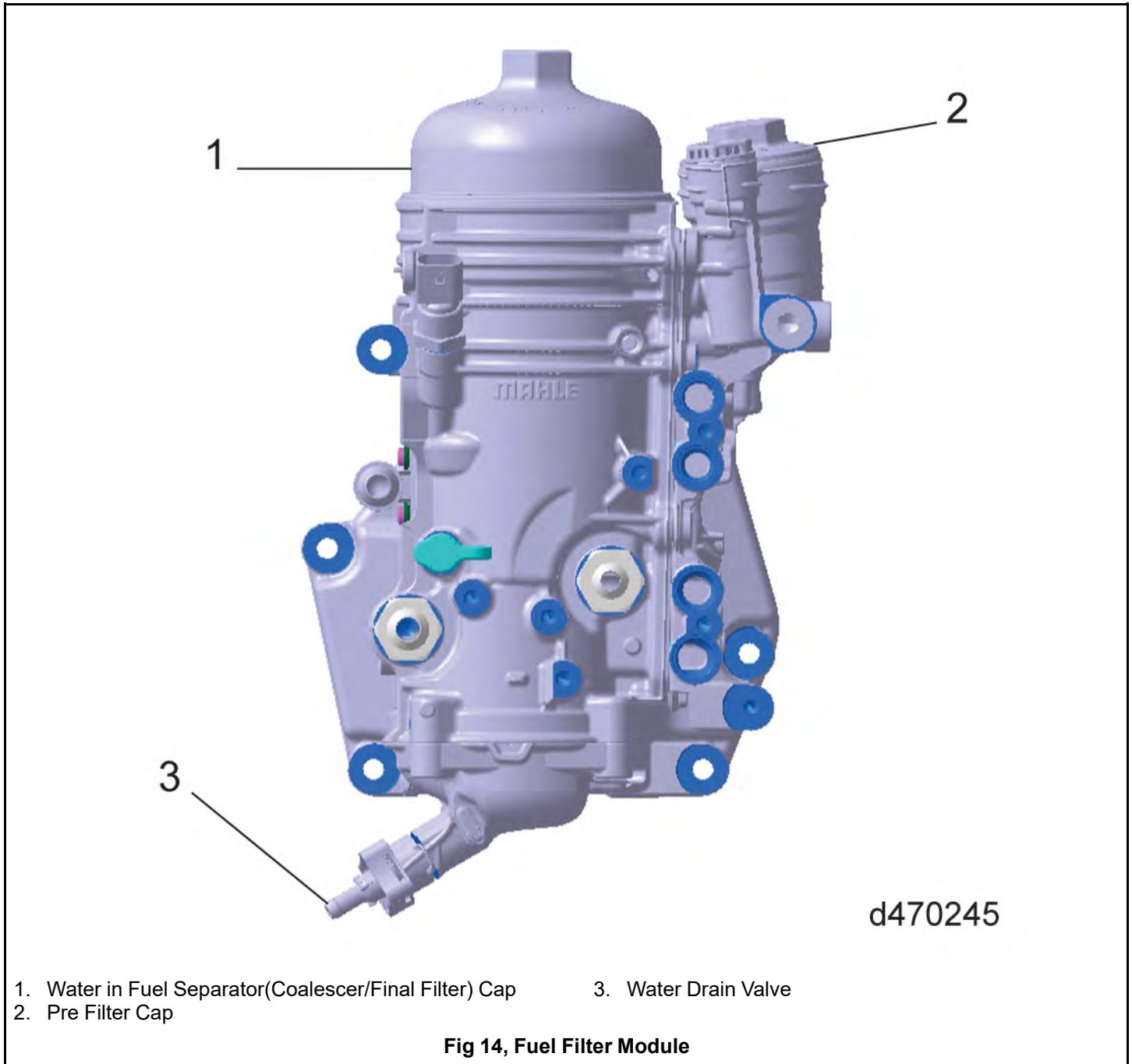

Fuel Filters

The prefilter is housed within the fuel filter module. The prefilter element filters particles down to 100 microns and is snapped into the prefilter cap. The coalescer/final filter is housed within the fuel filter module. The coalescer/final filter has the task of separating out the water contained in the fuel and also filtering out particles down to 3 to 5 microns. The coalescer/final filter snaps into the coalescer/final filter cap.

Air System

Air Cleaner - The air cleaner element should be inspected per the maintenance intervals or more often if the engine is operated under severe dust conditions.

Replace the element, if necessary. Check the gaskets for deterioration and replace, if necessary. If the dry type air cleaner is equipped with an aspirator, check for aspirator damage or clogging. Clean, repair or replace, as necessary.

NOTICE

Do not allow the air inlet restriction to exceed 5.5 kPa (22 in. H₂O) under any engine operating conditions. A clogged air cleaner element will cause excessive intake restriction and reduced air supply to the engine resulting in increased fuel consumption, inefficient engine operation and reduced engine life.

Inspect the entire air system for leaks daily. Look especially for torn air inlet piping or boots and loose or damaged clamps. Have worn or damaged parts repaired or replaced, as required. Retighten loose connections

Air Cleaner Replacement - Dry type air cleaner elements should be replaced after one year of service or when the maximum allowable air intake restriction has been reached, whichever comes first.

Air-to-Air Charge Cooler - Periodically inspect the air-to-air charge cooler for buildup of dirt, mud, etc. and wash off using a mild soap solution. Check the charge cooler, ductwork, and flexible connections for leaks and have repaired or replaced, as required.

Exhaust System

The exhaust manifold retaining bolts and other connections should be inspected for leaks. The exhaust pipe rain cap should be checked for proper operation, if so equipped.

Air Compressor

The air compressor incorporates three of the major systems of a diesel engine (air, lubrication, and coolant). Proper inspection of air compressor would include inspecting for air, oil, and coolant leaks. Due to inadequate internal sealing air compressors, when failed, can produce excessive crankcase pressure or allow an engine to ingest oil.

Vibration Damper

The viscous vibration damper should be inspected periodically and replaced if dented or leaking. Heat from normal engine operation may, over a period of time, cause the fluid within the damper to break down and lose its dampening properties. For this reason the viscous vibration damper must be replaced at time of normal major engine overhaul, regardless of apparent condition.

12.02 EuroV Maintenance Tables - 93K222(CK-4) and 93K223(FA-4)

NOTE: Actual fuel filter life will vary based on fuel quality.

93K222(CK-4) and 93K223(FA-4) Oil Service Interval Definitions (applies to the following tables):

Efficient Long Haul(over-the-road transport) service applies to vehicles that annually travel more than 100,000 kilometers and average greater than 3 km per liter with minimal city stop-and-go operation and minimum idle.

Long Haul Applies to vehicles that travel more than 100,000 kilometers annually, with an average fuel economy between 2.6 and 2.9 km/l, with load factor up to 44%, idle time up to 20%.

Examples: Long distance road service (interstate transport), minimum stop operation and city start.

Short Haul Applies to vehicles that travel annually from 48,000 to 100,000 kilometers, with average fuel economy between 2.2 and 2.5 km / l, with load factor greater than or equal to 45%, idle time between 25% -30%.

Examples: operation mainly in cities and densely populated areas, local transport with intermittent road trips, high percentage of stoppage and start operation.

Severe Applies to vehicles that travel annually up to 48,000 kilometers or that operate under severe conditions, with average fuel economy up to 2.1 km/l, load factor greater than 55%, idle time greater than 35%.

Examples:

- operating on roads that are unpaved or extremely damaged
- operating in an environment with a high accumulation of dust

- operating with constant exposure to extreme heat, cold, salt-air or other extreme climates
- operating on frequent trips of short distances
- operating on construction sites or farms

DD13, DD16: Maintenance Intervals				
(Note: Up to 50 ppm Sulfur Fuel is acceptable for this application.)				
EuroV Using DFS 93K222(CK-4) or 93K223(FA-4) Approved Oils				
Component	Efficient Long Haul 3.0 km/l or better*** (7.0 mpg or better)	Long Haul 2.6 to 2.9 km/l*** (6.0 to 6.9 mpg)	Short Haul † 2.2 to 2.5 km/l*** (5.1 to 5.9 mpg)	Severe † Up to 2.1 km/l*** (Up to 5.0 mpg)
Oil Filter	Replace every 75,000 km	Replace every 60,000 km	Replace every 44,000 km, 1000 hrs or 1 year†	Replace every 30,000 km, 750 hrs or 6 months†
Lubricating Oil	Replace every 75,000 km	Replace every 60,000 km	Replace every 44,000 km, 1000 hrs or 1 year†	Replace every 30,000 km, 750 hrs or 6 months†
Engine Fuel Filter *	Replace every 75,000 km	Replace every 60,000 km	Replace every 44,000 km, 1000 hrs or 1 year†	Replace every 30,000 km, 750 hrs or 6 months†
Engine Fuel Filter * w/ Frame-Mounted Filter	Replace every 150,000 km	Replace every 120,000 km	Replace every 88,000 km, 1000 hrs or 1 year†	Replace every 60,000 km, 750 hrs or 6 months†
Frame Mounted Fuel Fil- ters ‡	Replace every 75,000 km	Replace every 60,000 km	Replace every 44,000 km, 1000 hrs or 1 year†	Replace every 30,000 km, 750 hrs or 6 months†
Engine Steam Clean	At every oil change (to remove particle buildup, grime, salt and normal fluid seepage) See 13.01.18 Steam Cleaning the Engine			
Valve Lash Adjustment	Adjust at 320,000 km, then at 800,000 km, and then every 800,000 km thereafter.			Adjust every 320,000 km
Coolant - Standard Life	Maintain every 75,000 km or 1 year† Replace every 482,000 km	Maintain every 60,000 km or 1 year† Replace every 482,000 km	Maintain every 44,000 km, 1000 hrs or 1 year† Replace every 482,000 km	Maintain every 30,000 km, 750 hrs or 6 months† Replace every 482,000 km
Coolant - Extended Life	Maintain every 150,000 km or 1 year† Replace every 965,000 km	Maintain every 120,000 km or 1 year† Replace every 965,000 km	Maintain every 88,000 km, 2000 hrs or 1 year† Replace every 965,000 km	Maintain every 60,000 km, 1500 hrs or 1 year† Replace every 965,000 km
Belts	Inspect at Oil Change Replace every 225,000 km	Inspect at Oil Change Replace every 180,000 km	Inspect at Oil Change Replace every 132,000 km or 3000 hrs†	Inspect at Oil Change Replace every 90,000 km or 2250 hrs†
Air System	Inspect at oil change	Inspect at oil change	Inspect at oil change	Inspect at oil change
Air Cleaner	Inspect at oil change	Inspect at oil change	Inspect at oil change	Inspect at oil change
Exhaust System	Inspect at oil change	Inspect at oil change	Inspect at oil change	Inspect at oil change

DD13, DD16: Maintenance Intervals (Note: Up to 50 ppm Sulfur Fuel is acceptable for this application.)				
EuroV Using DFS 93K222(CK-4) or 93K223(FA-4) Approved Oils				
Component	Efficient Long Haul 3.0 km/l or better*** (7.0 mpg or better)	Long Haul 2.6 to 2.9 km/l*** (6.0 to 6.9 mpg)	Short Haul † 2.2 to 2.5 km/l*** (5.1 to 5.9 mpg)	Severe † Up to 2.1 km/l*** (Up to 5.0 mpg)
Air Compressor	Inspect at oil change	Inspect at oil change	Inspect at oil change	Inspect at oil change
Aftertreatment Devices	Inspect external hardware and connections every 6 months or at oil change intervals. †			
DEF Pump Filter	Replace every 800,000 km or 3 years	Replace every 650,000 km or 3 years	Replace every 475,000 km or 3 years	Replace every 325,000 km or 3 years
<p style="text-align: center;">- †Which ever comes first. Note: Reaching the Davco change line supersedes these intervals.</p> <p style="text-align: center;">- *Engine fuel filters should be changed at recommended service intervals, or when the "Fuel Filter Service Lamp" activates on the dashboard. For maximum life of fuel system components, it is not recommended to exceed 160,000 km on engine fuel filters under any condition.</p> <p style="text-align: center;">- ***Fuel Economy represents overall fuel economy (including idle time)</p> <p style="text-align: center;">- ‡Currently, only Detroit™ Fuel Filter/Water Separator & Davco 482/485/487 are the only frame-mounted filtration systems compatible for Detroit™ Engines.</p> <p style="text-align: center;">Refer to "Routine Preventive Maintenance" and "How To Procedures" for a description of all items.</p>				

13.01 Routine Preventive Maintenance	86
13.01.01 Monitoring the Lubricating Oil.....	86
13.01.02 Monitoring the Lubricating Oil Filter	88
13.01.03 Monitoring the Cooling System.....	88
13.01.04 Inspection of the Radiator	89
13.01.05 Monitoring the Fuel Filters.....	90
13.01.06 Adjusting the Valve Lash.....	90
13.01.07 Monitoring the Belt Tensioner	90
13.01.08 Poly-V-Belt Inspection	90
13.01.09 Monitoring the Serpentine Belts.....	93
13.01.10 Inspection of the Air Intake System.....	93
13.01.11 Monitoring the Air Cleaner.....	93
13.01.12 Monitoring the Exhaust System	93
13.01.13 Inspection of the Air Compressor.....	94
13.01.14 Monitoring the Fuel and Fuel Tank.....	94
13.01.15 Inspection of Hoses and Fittings for Fuel Leaks	94
13.01.16 Inspection of the Turbocharger and Charge Air Cooler	95
13.01.17 Inspection of the Battery	95
13.01.18 Steam Cleaning the Engine	97
13.01.19 Inspection of the Battery-Charging Alternator	97
13.01.20 Lubricating the Fan Hub	97
13.01.21 Checking the Vibration Damper.....	97

13. Routine Preventive Maintenance

13.01 Routine Preventive Maintenance

This section describes the items listed in the maintenance interval tables. The Daily instructions apply to routine or daily starting of the engine. They do not apply to a new engine or one that has been operated for a considerable period of time.

13.01.01 Monitoring the Lubricating Oil

Perform the following maintenance on the lubricating oil:

1. Check the oil level daily with the engine stopped and on a level surface. If the engine has just been stopped and is warm, wait approximately 20 minutes to allow the oil to drain back into the oil pan before checking.

NOTE: Some dipsticks have a positive locking device such as a lever or twist-lock design that must be disengaged before pulling the dipstick out of the guide tube. Use a shop rag to wipe off the end of the dipstick. Wait 15 seconds to allow any crankcase pressure to dissipate through the guide tube and let the oil level settle in the oil pan.

2. Add the proper grade of oil to maintain the correct level on the dipstick. Remove the dipstick from the guide tube. Before adding lubricating oil. See [How to Select Lubricating Oil](#). For EPA07 engines see [How to Select Lubricating Oil \(EPA07\)](#).
3. Reinstall the dipstick and make sure it is fully inserted into the guide tube. Remove the dipstick and read the oil level dipstick.
4. Check the oil level daily. With the engine stopped, use the oil dipstick and measure the oil level on crosshatch area on the dipstick. The figures below show maximum oil level (2) and minimum oil level (1). If the oil reading is between the min and max indicators, then the oil is at the proper level for engine operation.



d180205

80205

Fig 15, Oil Dipstick - Metal Indicator

80205

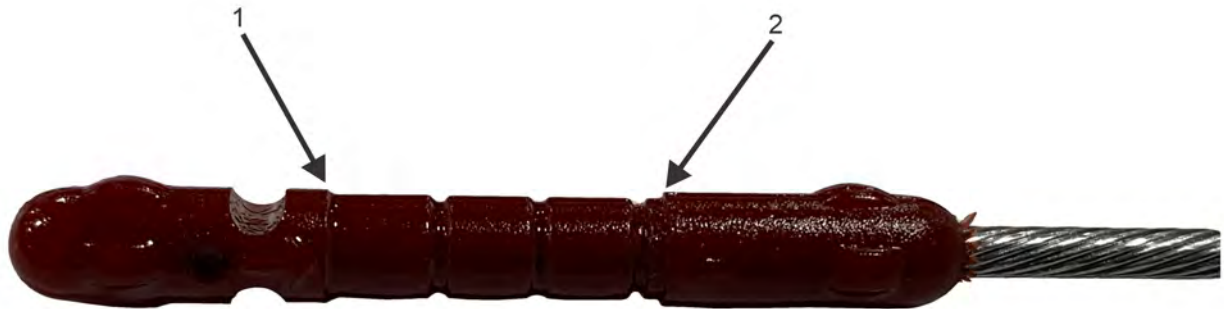

d180204

Fig 16, Oil Dipstick - Plastic Indicator

5. Add the proper grade of oil to maintain the satisfactory range on the dipstick. All diesel engines are designed to use some oil, so the periodic addition of oil is normal. Before adding lubricating oil. See [How to Select Lubricating Oil](#). For EPA07 engines see [How to Select Lubricating Oil \(EPA07\)](#).

13.01.02 Monitoring the Lubricating Oil Filter

The engines are equipped with a single cartridge-style oil filter (1) that is part of the oil/coolant module. Incorporated into the housing is a drain back port which allows residual oil to be returned to the oil pan when the filter is removed. This design, including the cartridge style element, allows for a more environmentally-safe oil change.

Perform the following maintenance on the Lubricating Oil Filter:

1. Replace the oil filters when recommended by the appropriate maintenance table.
[EuroV Maintenance Tables - 93K222\(CK-4\) and 93K223\(FA-4\)](#)
[EuroV Maintenance Tables - 93K222\(CK-4\) and 93K223\(FA-4\)](#)
2. Make a visual check of all lubricating oil lines for wear and/or chafing. If any indication of wear is evident, replace the oil lines and correct the cause.
3. Check for oil leaks after starting the engine.

13.01.03 Monitoring the Cooling System

The cooling system must be *full* for proper operation of the engine.

**WARNING:*****HOT COOLANT***

To avoid scalding from the expulsion of hot coolant, never remove the cooling system pressure cap while the engine is at operating temperature. Wear adequate protective clothing (face shield, rubber gloves, apron, and boots). Remove the cap slowly to relieve pressure.

1. Check the coolant level daily and maintain it between the full and low marks on the surge tank.
2. Add coolant as required, but do not overfill. Before adding coolant, [Coolant Selections and Maintenance](#) [Coolant Selections and Maintenance](#) for the listing of required intervals using the recommended coolants.

Checking for Coolant Leaks

Perform daily visual checks for cooling system leaks. Look for an accumulation of coolant when the engine is running and when it is stopped.

NOTE: Coolant leaks may be more apparent on a engine when it is cold.

**WARNING:*****PERSONAL INJURY***

To avoid injury before starting and running the engine, ensure the vehicle is parked on a level surface, parking brake is set, and the wheels are blocked.

Coolant Inhibitors

The inhibitors in antifreeze solutions must be replenished with an approved corrosion inhibitor supplement when indicated by testing the coolant. [Coolant Selections and Maintenance](#) for the listing of required intervals using the recommended coolants for required test intervals, inhibitor levels, and approved inhibitors.

NOTICE

Coolant must be inhibited with the recommended Supplemental Coolant Additives listed in this manual. Failure to check and maintain Supplemental Coolant Additive levels at required concentrations will result in severe damage (corrosion) to the engine cooling system and related components.

The cooling system is protected by a Supplemental Coolant Additive element.

Coolant Drain Interval

A coolant system properly maintained and protected with supplemental coolant inhibitors can be operated up to the intervals listed. At these intervals the coolant must be drained and disposed of in an environmentally responsible manner according to state and/or federal recommendations.

13.01.04 Inspection of the Radiator

Inspect the radiator as follows:

1. Inspect the exterior of the radiator core every 30,000 miles (50,000 km) or 12 months.

**WARNING:****EYE INJURY**

To avoid injury from flying debris when using compressed air, wear adequate eye protection (face shield or safety goggles) and do not exceed 276 kPa (40 psi) air pressure.

2. If necessary, clean the exterior using a quality grease solvent, such as mineral spirits, and dry with compressed air. Do not use fuel oil, kerosene, or gasoline.
3. If the low coolant level sensor is installed in the top tank of the radiator, test for proper operation every 100,000 miles (160,000 km) or 12 months, whichever comes first. Authorized Detroit™ distributors are properly equipped to perform this service.

13.01.05 Monitoring the Fuel Filters

Monitoring the Two-Filter Fuel System Filters

The engine is equipped with a prefilter that filters down to 100 microns, a coalescer/final filter that separates water, and filters down to 3 to 5 microns. When servicing these elements, all two filters should be changed at the same time. All two elements are located within the fuel filter module located on the left side of the engine.

NOTICE

Do not over-tighten the water drain valve. Failure to properly tighten the water drain valve may cause damage to the water drain valve and housing.

NOTE: Filter change intervals may be shortened to conform with established preventive maintenance schedules, but should never be extended.

1. Replace the fuel filters using the Preventative Maintenance Tables.

13.01.06 Adjusting the Valve Lash

NOTE: Proper valve lash clearance allows the engine to produce the best possible performance with the lowest emissions. Valve lash adjustments should be performed by an authorized Detroit™ maintenance or repair facility.

Perform a valve lash adjustment as scheduled for the appropriate engine duty cycle.

13.01.07 Monitoring the Belt Tensioner

DD Platform engines are equipped with an automatic tensioning device. No adjustment or periodic maintenance is required.

13.01.08 Poly-V-Belt Inspection

Periodically inspect the belts based on the damage guide below. If any damage is noted, replace both belts (Fan and Accessory Belts). A precision wear gauge, available from Gates®, is the preferred method of determining belt wear.

Poly-V-Belt Inspection Concerns	
ABRASION	CHUNK-OUT
 <p>A black poly-V-belt is shown in a curved position. The outer surface of the belt is heavily worn and appears rough and textured. A white arrow points to the abraded area.</p> <p>d130019</p>	 <p>A black poly-V-belt is shown in a curved position. A significant portion of the outer surface has been missing, exposing the internal structure. A white arrow points to the missing section.</p> <p>d130020</p>
IMPROPER INSTALL	CRACKING
 <p>A black poly-V-belt is shown in a curved position. The belt is twisted, and the V-shaped grooves are not aligned properly. A white arrow points to the twisted section.</p> <p>d130021</p>	 <p>A black poly-V-belt is shown in a curved position. The outer surface of the belt shows several deep, longitudinal cracks. A white arrow points to the cracked area.</p> <p>d130022</p>

Poly-V-Belt Inspection Concerns	
PILLING	UNEVEN RIB WEAR
 <p>d130023</p>	 <p>d130024</p>
MISALIGNMENT	GRAVEL PENETRATION
 <p>d130025</p>	 <p>d130026</p>

13.01.09 Monitoring the Serpentine Belts

Two poly-V-belts (8 and 9) are used on the engine for On-Highway Vehicle applications. One belt drives the fan hub and the other belt drives the remaining accessories. To provide proper running tension, the system utilizes an automatic tensioning device. Automatic belt tensioners require no adjustment.

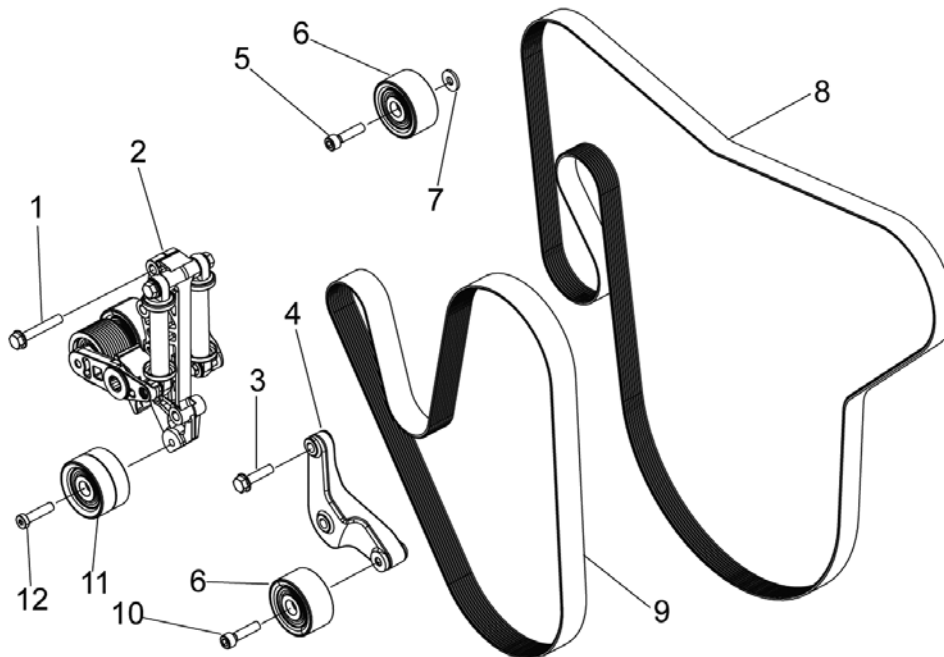

d200007

Replacement of Belts

DD Platform engines utilize a specially designed EPDM belt material which is exclusive to the OE component. Replacement with an aftermarket part may lead to shortened maintenance intervals and excessive noise.

If the vehicle is operated in severely cold/hot temperatures, or is exposed to significant dust/debris/road salt, the belts may require replacement prior to mileage specified in the maintenance interval section.

13.01.10 Inspection of the Air Intake System

Perform the following maintenance on the Air Intake System:

1. Inspect all the connections in the air system to make sure they are tight and leak-free.
2. Check all hoses and ducting for punctures, deterioration, or other damage and replace, if necessary.

13.01.11 Monitoring the Air Cleaner

The engine is equipped with an engine-mounted air cleaner that is flat in design to accommodate various vehicle packages. Replace dry-type air cleaner elements when the maximum allowable air intake restriction has been reached.

1. Check the air cleaner restriction gauge (filter minder) daily. Refer to section "Air Cleaner Inspection" in the vehicle's maintenance manual.
2. Check the gaskets for deterioration and replace, if necessary.
3. Inspect the entire air system daily for leaks daily. Look especially for torn air inlet piping or boots, and loose or damaged clamps. Have worn or damaged parts repaired or replaced. Re-tighten loose connections.

13.01.12 Monitoring the Exhaust System

Inspect the Exhaust System as follows:

1. Check the exhaust manifold retaining bolts and other connections for tightness.

2. Check the exhaust pipe rain cap for proper operation, if so equipped.

13.01.13 Inspection of the Air Compressor

The air compressor incorporates three of the major systems of a diesel engine (air, lubrication, and cooling). Inspect the air compressor looking for air, oil, and coolant leaks.

13.01.14 Monitoring the Fuel and Fuel Tank

To prevent fuel and fuel tank problems, the following measures are recommended:

1. Keep the fuel tank filled to reduce condensation.
2. Before adding fuel, .
3. Refill the tank at the end of each day's operation to prevent condensation from contaminating the fuel. Condensation formed in a partially filled tank promotes the growth of microorganisms that can clog fuel filters and restrict fuel flow.
4. Open the drain at the bottom of the fuel tank every 30,000 miles (50,000 kilometers) to drain off any water and/or sediment.



WARNING:

PERSONAL INJURY

To avoid injury from improper use of chemicals, follow the chemical manufacturer's usage, handling, and disposal instructions. Observe all manufacturer's cautions.

5. Every 120,000 miles (200,000 kilometers) or 12 months, tighten all fuel tank mountings and brackets. At the same time, check the seal in the fuel tank cap, the breather hole in the cap, and the condition of the flexible fuel lines. Repair or replace the parts, as necessary.

13.01.15 Inspection of Hoses and Fittings for Fuel Leaks

A pre-start inspection of hoses and fuel lines is recommended. Make a visual check for fuel leaks at all engine-mounted fuel lines and connections, and at the fuel tank suction and return lines. Since fuel tanks are susceptible to road hazards, leaks in this area may best be detected by checking for an accumulation of fuel under the tank.



WARNING:

HOT OIL

To avoid injury from hot oil, do not operate the engine with the rocker cover(s) removed.

NOTE: Leaks are not only detrimental to machine operation, but they can also result in added expense caused by the need to replace lost fluids

Inspection of Hoses and Fittings

Check hoses daily as part of the pre-start inspection.

- Examine hoses for leaks, and check all fittings, clamps and ties carefully.
- Make sure hoses are not resting on or touching shafts, couplings, heated surfaces including exhaust manifolds, sharp edges, or other obvious hazardous areas.

- Since all machinery vibrates and moves to a certain extent, clamps and ties can fatigue with age. To ensure continued proper support, inspect fasteners frequently and tighten or replace them as necessary.
- If fittings have loosened or cracked, or if hoses have ruptured or worn through, take corrective action immediately.

Inspection of Hoses with Extended Service Life

A hose has a finite service life. With this in mind, inspect hoses as follows:

NOTE: Fire-resistant fuel and lubricating oil hose assemblies do not require automatic replacement after five years of service or at major overhaul, but should be inspected carefully before being put back into service.

1. Thoroughly inspect all hoses at least every 500 operating hours (1,000 hours for fire-resistant fuel and lubricating oil hoses) and/or annually. Look for cover damage and/or indications of twisted, worn, crimped, brittle, cracked or leaking lines. Hoses with their outer cover worn through or with damaged metal reinforcements should be considered unfit for further service.
2. Replace all hoses in and out of machinery during major overhaul and/or after a maximum of five (5) years of service.

13.01.16 Inspection of the Turbocharger and Charge Air Cooler

Inspect turbocharger and charge air cooler as follows:

1. Visually inspect the turbocharger mountings, intake and exhaust ducting, and connections for leaks daily.
2. Check the lubricating oil inlet and outlet lines for leaks or restrictions to oil flow.

**WARNING:*****PERSONAL INJURY***

To avoid injury from hot surfaces, wear protective gloves, or allow engine to cool before removing any component.

3. Check the turbocharger for unusual noise or vibration and, if excessive, stop the engine and do not operate until the cause is determined.
4. Periodically inspect the air-to-air charge air cooler for buildup of dirt, mud, or other debris. Clean as necessary.
5. Check the charge air cooler, duct work, and flexible connections for leaks and repair or replace as required.

13.01.17 Inspection of the Battery

Inspect the battery as follows:

**WARNING:*****PERSONAL INJURY***

To avoid injury from accidental engine startup while servicing the engine, disconnect/disable the starting system.

1. Check for cracks in the battery cases (1), for tightness of the cable clamps (2) at the terminals, and for corrosion of the terminals (3). Service or replace as needed.

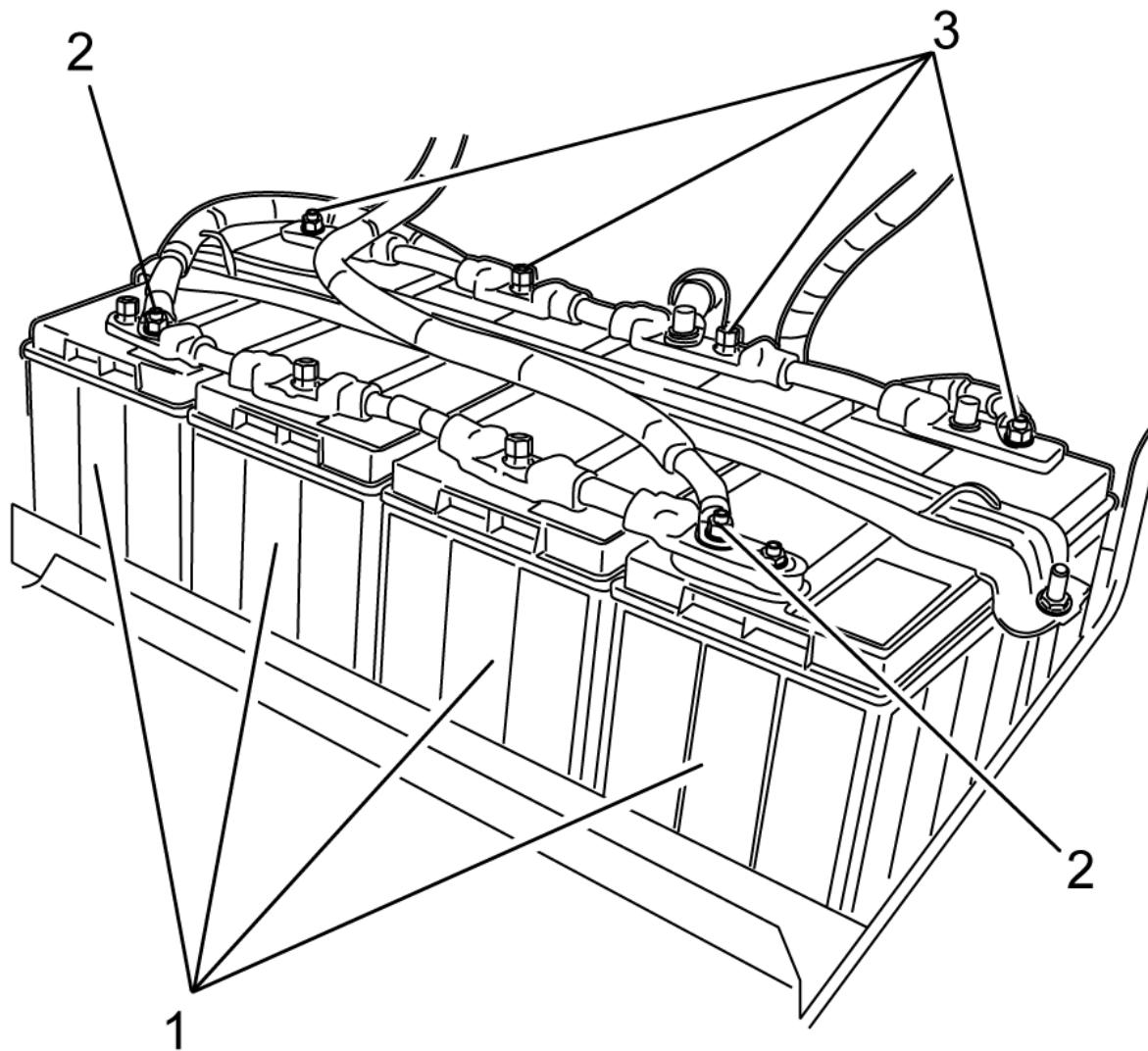

d540077

2. Keep the terminal surface clean.
3. Inspect the cables, clamps and hold-down brackets regularly. Clean and reapply a light coating of petroleum jelly when needed. Have corroded or damaged parts replaced.
4. If the engine is to be out of service for more than 30 days, remove the batteries and store in a cool, dry place.
 - 4.a Keep batteries fully charged, if possible.
 - 4.b Replace any battery that fails to hold a charge.
5. Periodically check battery connections for corrosion and tightness.
 - 5.a If necessary, remove connections and wire brush any corrosion from terminals and cable ends.
 - 5.b Replace damaged wiring.

13.01.18 Steam Cleaning the Engine

NOTICE

Do not apply steam or solvent directly to the battery-charging alternator, starting motor, DDEC components, sensors or other electrical components, as damage may result.

The engine and engine compartment should be steam cleaned at every oil change.

13.01.19 Inspection of the Battery-Charging Alternator

Precautions must be taken when working on or around the alternator. The diodes and transistors in the alternator circuit are very sensitive and can be easily destroyed. To avoid equipment damage, the following conditions must be met:

**WARNING:*****BATTERY EXPLOSION AND ACID BURN***

To avoid injury from battery explosion or contact with battery acid, work in a well ventilated area, wear protective clothing, and avoid sparks or flames near the battery. If you come in contact with battery acid:

- Flush your skin with water.
- Apply baking soda or lime to help neutralize the acid.
- Flush your eyes with water.
- Get medical attention immediately.

- Avoid grounding the output terminal. Grounding an alternator output wire or terminal (which is always hot, regardless of whether or not the engine is running) and accidentally reversing the battery polarity will result in equipment damage.
- Do not reverse battery connections.
- Never disconnect the battery while the alternator is operating. Disconnecting the battery can result in damage to the battery diodes. In applications which have two sets of batteries, switching from one set to the other while the engine is running will momentarily disconnect the batteries.
- If a booster battery is to be used, batteries must be connected correctly (negative to negative, positive to positive).
- Never use a fast charger with the batteries connected or as a booster for battery output.

For information on the alternator assembly, contact an authorized distributor, depending on manufacturer.

Check the alternator as follows:

1. Inspect the terminals for corrosion and loose connections and wiring for damage and frayed insulation. Have wiring repaired or replaced, as required.
2. Check torque on alternator mounting bolts and bracketing every 30,000 miles (50,000 km). Re-tighten if necessary.

13.01.20 Lubricating the Fan Hub

If the fan bearing hub assembly has a grease fitting, use a hand grease gun to lubricate the bearings with one shot of quality lithium-based, multipurpose grease every 120,000 miles (200,000 km). Care should be taken not to overfill the bearing housing.

13.01.21 Checking the Vibration Damper

Check the vibration damper as follows:

1. Inspect the viscous vibration damper (1) periodically and replace if dented or leaking.

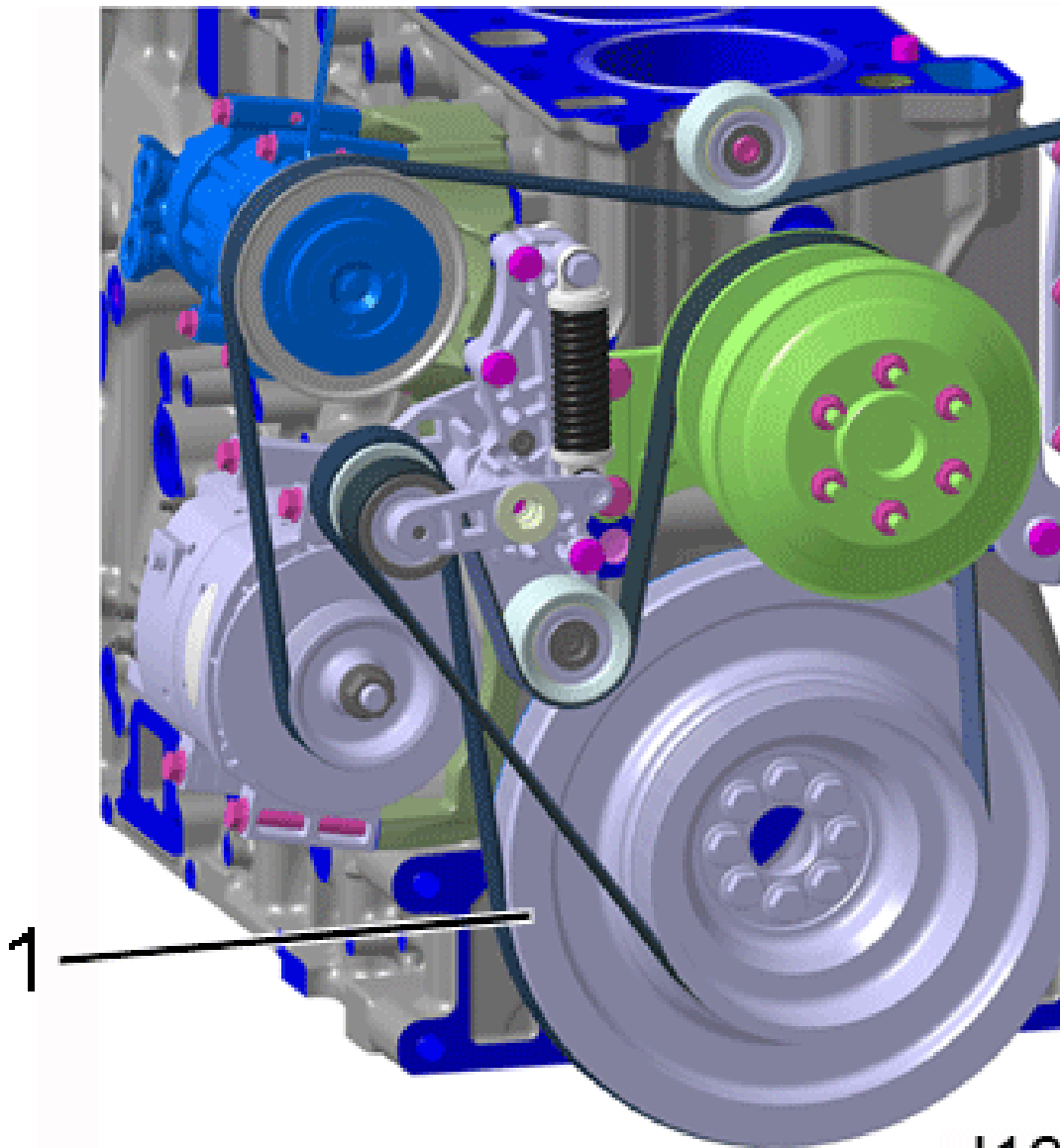

d130010

2. Heat from normal engine operation may, over a period of time, cause the fluid within the damper to break down and lose its dampening properties. For this reason, replace the viscous vibration damper at time of normal major engine overhaul, regardless of apparent condition.

14.01 How to Procedures	100
14.01.01 How to Select Lubricating Oil	100
14.01.02 Cold Weather Starting	100
14.01.03 When to Change Oil	101
14.01.04 How to Replace the Lubricating Oil and Oil Filter	101
14.01.05 How to Select Diesel Fuel	103
14.01.06 How to Replace the Fuel Filters	104
14.01.07 Engine Out of Fuel – How to Restart	109
14.01.08 How to Clean an Engine	110
14.01.09 Cleaning/Flushing the Cooling System	111
14.01.10 Coolant Selections and Maintenance	112
14.01.11 Coolant Fill Options	112
14.01.12 Coolant Do's and Don'ts	113
14.01.13 Maintenance	114
14.01.14 Appendix A - Definitions	118
14.01.15 Appendix B - General Coolant Information	118
14.01.16 Appendix C - Detroit™ Cooling System Maintenance Products	121
14.01.17 Checking the Hoses	123
14.01.18 How to Service the Dry Type Air Cleaner	123

14. How-To Procedures

14.01 How to Procedures

This section covers the Detroit™ recommendations on how to select lubricating oil, diesel fuel, and coolant. Also included are basic engine maintenance procedures which can be performed by the operator.

NOTICE

The manufacturer's warranty applicable to the engine provides in part that the provisions of such warranty shall not apply to any engine unit that has been subject to misuse, negligence or accident. Accordingly, malfunctions attributable to neglect or failure to follow the manufacturer's fuel or lubricating recommendations may not be within the coverage of the warranty.

14.01.01 How to Select Lubricating Oil

Refer to **DDC-SVC-BRO-0001** for more information.

Detroit Fluids Specification (DFS) DFS 93K223 (API FA-4) or DFS 93K222 (API CK-4) oils are recommended for use in the engine.



d470246e

For optimal fuel economy, use DFS 93K223 approved API FA-4 engine oil.

14.01.02 Cold Weather Starting

Refer to **DDC-SVC-BRO-0001** for more information.

Cold Weather Starting

NOTICE

Monograde oils should not be used in the engine, regardless of API service classification. Monograde oils gel at lower ambient temperatures, reducing lubricant flow, and do not provide adequate lubricity at higher engine operating temperatures resulting in severe engine damage.

For picking a lubricant for low temperature applications, [How to Select Lubricating Oil](#) or **DDC-SVC-BRO-0001**.

Use of Synthetic Oils

NOTE: Synthetic oil does not permit extension of recommended oil drain intervals.

Synthetic oils may be used in Detroit™ engines provided they are approved by a *DFS*. The use of synthetic oils does not necessarily ensure the extension of the recommended oil drain intervals beyond the limits.

Use of Supplemental Additives

Lubricants meeting the Detroit™ specifications outlined in this publication already contain a balanced additive treatment. Supplemental additives are generally not necessary and can even be harmful. These additives may be marketed as either oil treatments or engine treatments and are discouraged from use in Detroit™ engines.

Engine damage resulting from the use of such materials is not covered by your Detroit™ warranty. Detroit™ will not provide statements beyond this publication relative to their use.

14.01.03 When to Change Oil

Refer to DDC-SVC-BRO-0001 for more information.

The length of time an engine may operate before an oil change depends upon the lubricant and fuel used, engine oil consumption, and the operating cycle.

**CAUTION:****USED ENGINE OIL**

To avoid injury to skin from contact with the contaminants in used engine oil, wear protective gloves and apron.

Oil analysis may be used to determine whether this interval should be shortened, but it should not be used to lengthen the interval.

The use of fuels with sulfur content above 0.05 mass percent will require a shortening of drain intervals. **For more information refer to DDC-SVC-BRO-0001.**

Disposal of Waste Oil

Used lubricating oil and filters require disposal in an environmentally responsible manner, according to federal and/or state recommendations. The disposal of waste oil may be best addressed by the engine oil supplier, who may accept responsibility for proper disposal of this material as part of the business of providing lubricant.

14.01.04 How to Replace the Lubricating Oil and Oil Filter

The oil filter is an integral part of the lubrication system. Proper filter selection and maintenance are important to satisfactory engine performance and service life. The filter should be used to maintain a clean system, not to clean up a contaminated system. The maintenance intervals for the appropriate duty cycle are listed in tables in this manual.

Change the oil and replace the lubricating oil filter as follows:

NOTE: If the used oil was contaminated by fuel or coolant, it may be necessary to take the vehicle to a certified Detroit Service Center. The Service Center may drain the oil and then remove the oil pan, oil pump, and oil pump intake manifold to drain the remaining oil held back by the backflow valve. It is important to remove all contaminated oil from the engine.

NOTE: Change the engine oil only when the engine oil temperature is approximately 60°C (140°F). Changing cold oil will result in extended drain times.

1. Place the transmission in neutral, and set the parking brake.
2. Clean outside of the oil filter housing.
3. Using a 36-mm socket, unscrew the oil filter cap and filter and allow the oil to drain into the housing. After draining is complete, remove the assembly from the housing.
4. Remove the filter element by pressing and twisting the side and detaching it from the cap.
5. Remove the oil filter cap O-ring and discard. Lightly coat a new O-ring with clean engine oil and install it on the filter cap.

6. Check the filter housing for any debris and remove if necessary.
7. Insert a new filter element into the oil filter cap.
8. Inspect the oil filter bypass valve (3) in the end of the standpipe (2) in the oil filter housing. See illustration below. A broken bypass valve (1) is shown on the right. Repair as necessary.

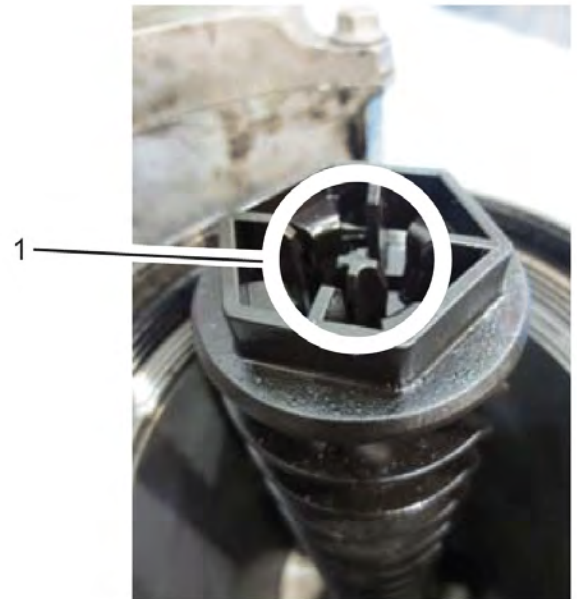
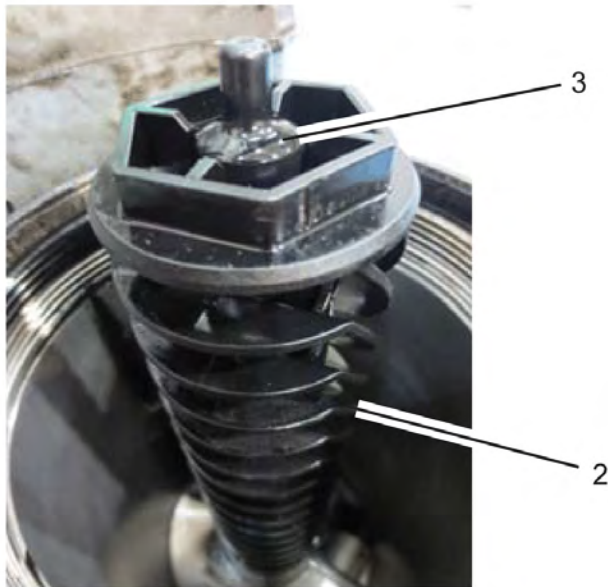

d180044

9. Insert the filter element and cap assembly into the housing. Torque the cap to 40 to 50 N·m (30 to 37 lb·ft).
10. Place a suitable drain pan, 47 L (50 qt) or more, under the oil pan.
11. Carefully unscrew the oil drain plug, and allow the oil to drain out.
12. Discard the oil drain plug sealing O-ring.
13. Install the oil pan drain plug with a new O-ring and torque the plug:
 - On a plastic oil pan, torque plug to 45 N·m +/- 7 N·m (33 lb·ft +/- 5 lb·ft).
 - On an aluminum oil pan, torque plug to 60 N·m +/- 9 N·m (44 lb·ft +/- 6 lb·ft).
14. Add new engine oil through the oil fill tube in the following amount; [Engine Oil Capacities](#). Verify the oil level reading is between the full and fill marks on the dipstick.
15. Start the engine with the accelerator pedal in the idle position (600 rpm). Monitor the oil pressure gauge or indicator lamp. Keep the engine running at idling speed (600 rpm) until the oil pressure reading is 10.2 psi (70 kPa) or more for the DD15/16 and 11.6 psi (80 kPa) or more for the DD13.
16. Check the filter housing for signs of leakage.

17. Stop the engine. Check the oil level again per the following guidelines. If necessary, add oil no more than 5.0 L (5.2 qt) at a time up to the maximum fill level on the oil dipstick.

14.01.05 How to Select Diesel Fuel

Quality

NOTICE

To ensure maximum engine performance for EuroV applications, Ultra Low Sulfur Diesel fuel (ULSD) (15 PPM sulfur content maximum), based on ASTM Standard D 2622 test procedure is recommended. However, due to varying fuel quality in these markets, up to 50 ppm sulfur diesel fuel is acceptable for this application.

NOTICE

Fuel quality is an important factor in obtaining satisfactory engine performance, long engine life, and acceptable exhaust emission levels. **For fuel quality specifications and limits refer to DDC-SVC-BRO-0001.**



d470246f

The fuels used must be clean, completely distilled, stable, and non-corrosive. For more information regarding the significance of these properties and selection of the proper fuel.

Fuel Contamination

Generally, fuel contamination occurs as the result of improper fuel handling. The most common types of contamination are water, dirt, and microbial growth "black slime". The formation of varnishes and gums resulting from poor stability or extended storage "stale fuel" also affects fuel quality. The best treatment for contamination is prevention by maintaining a clean storage system and choosing a reputable fuel supplier.

Supplemental additives are not recommended due to potential injector system or engine damage. Our experience has been that such additives increase operating costs without providing benefit.

The use of supplemental fuel additives does not necessarily void the engine warranty. However, repair expenses which result from fuel system or engine component malfunctions or damage attributed to their use will not be covered.

Biodiesel General Recommendations and Guidelines

Detroit® supports biodiesel as a renewable fuel. Biodiesel fuels are mono alkali esters of long chain fatty acids commonly referred to as Fatty Acid Methyl Esters (FAME) and are derived from renewable resources through a chemical process called transesterification.

Detroit® approves the use of biodiesel fuel blends as follows:

- DD Eurov Family of Engines - B12 Biodiesel blends are allowed

For most recent information go to DTNAConnect.

Prohibited Additives

The following fuel additives are not allowed and MUST NOT be mixed with diesel fuel:

- **Used Lubricating Oil** Do not use fuel blended with used lubricating oil. Detroit™ specifically prohibits the use of used lubricating oil in diesel fuel. Used lubricating oil contains combustion acids and particulate materials which can severely erode fuel injector components, resulting in loss of power and increased exhaust emissions. In addition, the use of drained lubricating oil will increase maintenance requirements due to filter plugging and combustion deposits.



WARNING:

FIRE

To avoid increased risk of a fuel fire, do not mix gasoline and diesel fuel.

NOTICE

Detroit™ will not be responsible for any detrimental effects resulting from adding drained lubricating oil or gasoline to the diesel fuel.

Gasoline The addition of gasoline to diesel fuel will create a serious fire hazard. The presence of gasoline in diesel fuel will reduce fuel cetane number and increase combustion temperatures. Drain and clean tanks which contain a mixture of gasoline and diesel fuel as soon as possible.

- **Fuel Additives with Sulfur or Sulfated Ash** Do not use non-approved fuel additives containing sulfur or sulfated ash.

14.01.06 How to Replace the Fuel Filters

NOTICE

If you have just changed the engine oil and filter, you **MUST** start the engine and confirm proper oil pressure before changing the fuel filters. If no oil pressure is shown after approximately 10 seconds, stop the engine and determine the cause. Running the engine with no oil pressure could result in engine damage. Start the engine with the accelerator pedal in the idle position. Monitor the oil pressure gauge or indicator lamp. Keep the engine running at idling speed until the oil pressure reading is 97 kPa (14 PSI) or more.

NOTE: If you are replacing all fuel filters, it is not necessary to run the engine and test for leaks after installing each individual fuel filter. However, if repairing a leak at one filter, complete that repair and test the system for leaks after priming the fuel system.

Filters are an integral part of the fuel system. Proper filter selection and maintenance are important to satisfactory engine operation and service life. Filters should be used to maintain a clean system, not to clean up a contaminated system. The scheduled maintenance intervals for the appropriate duty cycles are listed in this manual.



WARNING:

PERSONAL INJURY

To prevent the escape of high pressure fuel that can penetrate skin, ensure the engine has been shut down for a minimum of 10 minutes before servicing any component within the high pressure circuit. Residual high fuel pressure may be present within the circuit.

NOTICE

At cold temperatures (-40° C or -40° F), DO NOT remove the filter elements from the caps unless the intent is to replace the filter elements. Repeated removals at cold temperatures may break the filter element tabs.

Removal of the Fuel Prefilter - Two-Filter System

Remove the prefilter as follows:

1. Using a 36 mm socket, unscrew the prefilter cap.
2. Pull the cap and prefilter straight up and out of the fuel filter housing.
3. Remove the prefilter (1) from the prefilter cap (2) by placing the filter on a solid surface and apply pressure on prefilter cap (2) at an angle.



d470163

4. Discard the prefilter cap seal ring.

Installation of the Fuel Prefilter - Two-Filter System

Install the fuel prefilter as follows:

NOTE: If a filter service is being performed, replace all other filters before priming.

1. Install a new prefilter cap seal ring on to the prefilter cap.
2. Snap new prefilter into the prefilter cap.
3. Apply a thin coat of petroleum-based lithium grease to the prefilter cap seal ring and the prefilter seals (1).



d470162

4. Install the prefilter into the fuel filter module.
5. Turn the cap counterclockwise until a click sound is made, then turn clockwise and hand-tighten.
6. Torque prefilter cap to 55 to 60 N·m (41 to 44 ft·lb).
7. Once all required filters have been changed, prime the fuel system.

[Priming the Fuel System - KM63 GEN2 - Two-Filter System](#)

[Priming the Fuel System - KM59 GEN1 - Two-Filter System](#)

Removal of the Water Coalescer/Final Filter - Two-Filter System

Remove the water coalescer/final filter as follows:

NOTICE

Do not tilt the water coalescer/final filter when removing it from the housing. Possible damage to the water coalescer/final filter or stand pipe may occur.

1. Using a 36mm socket, unscrew the water coalescer/final filter cap.
2. Pull the cap and water coalescer/final filter straight up and allow the fuel to drain back.
3. Remove the water coalescer/final filter (2) from the water coalescer/final filter cap (1) by placing the filter on a solid surface with the drain back plug location at 12 o'clock (3) and apply pressure on the water coalescer/final filter cap at an angle.



d470164

4. Discard the water coalescer/final filter.
5. Inspect inside the housing for any large debris, clean housing as needed.
6. Discard water coalescer/final filter cap seal ring.

Installation of the Coalescer/Final Filter - Two-Filter System

Install the water coalescer/final filter as follows:

NOTE: If a fuel filter service is being performed, replace all other fuel filters before priming the fuel system.

1. Install a new seal ring on to water coalescer/final filter cap.
2. Snap a new water coalescer/final filter into the water coalescer/final filter cap.
3. Apply a light coat of Parker super O-lube or petroleum-based lithium grease to the water coalescer/final filter cap seal ring and drain back plug seal ring (C). Apply a heavy coat of Parker super O-lube or petroleum-based lithium grease to the upper (A) and lower seals (B) on the water coalescer/final filter.



d470165a

The illustration below shows the proper amount of lubricant to use on the upper and lower seals.



d470301

4. Install the water coalescer/final filter into the fuel filter module.
5. **Turn the water coalescer/final filter cap counterclockwise until the drain back plug has located the drain back port.** Apply light pressure to the top of the water coalescer/final filter cap to seat the drain back plug into the drain back port, hand tighten the filter cap by turning the cap clockwise.
6. Torque water coalescer/final filter cap to 55 to 60 N·m (41 to 44 lb·ft).
7. Once all required filters have been changed, prime the fuel system.

[Priming the Fuel System - KM63 GEN2 - Two-Filter System](#)

[Priming the Fuel System - KM59 GEN1 - Two-Filter System](#)

14.01.07 Engine Out of Fuel – How to Restart

When an engine has run out of fuel, there is a definite procedure to follow when restarting it.

NOTICE

Never use the starting motor and fuel pump to prime the fuel filters. Prolonged use of the starting motor and fuel pump to prime the fuel system can result in damage to the starter, fuel pump, and injectors.

Use the following procedure to prime the fuel system:

1. Fill the fuel tank with the recommended grade of fuel. If only partial filling is possible, add a minimum of 10% of the total tank volume of fuel to the tank. For example, a 150-gallon tank would require a minimum of 15 gallons of fuel.
2. Connect a Detroit-approved priming tool or operate the engine-mounted hand primer for three minutes or 250 strokes.
3. Turn on the ignition switch.
4. Wait for the engine system indicator lights on the instrument panel to go out.
5. With the accelerator pedal in the idle position, start the engine.
6. Crank engine for 20 seconds.
7. If engine does not start, allow for a 60-second cool down and repeat previous step.
8. Monitor the oil pressure gauge or indicator lamp. Keep the engine running at an idling speed until a stable oil pressure reading of 97 kPa (14 psi) or more is maintained for one minute.
9. Check for leaks.
10. Allow the engine to reach operating temperature of 60° C (140° F).
11. Increase engine speed to 1800 rpm for three minutes.
12. Return the engine to idle and allow to idle for approximately one minute, then shut down the engine.
13. Check for leaks.
14. If engine still fails to start, contact an authorized Detroit™ repair facility.

14.01.08 How to Clean an Engine

Observance of all environmental protection regulations is required. Use high-pressure equipment as follows:



CAUTION:

EYE INJURY

To avoid injury from flying debris, wear a face shield or goggles.

NOTICE

To prevent damage to engine components, keep the water moving at all times while cleaning. Never direct water onto electrical components, plug connectors, seals or flexible hoses.

Information on suitable cleaning and protective products is available from any authorized dealer. Note the equipment manufacturer's operating instructions.

Use the following minimum working distance between the high-pressure nozzle and the surface being cleaned:

- Approximately 28 in. (700 mm) for circular pattern jets
- Approximately 12 in. (300 mm) for 25-degree flat jets and dirt cutters

Power clean the engine as follows:

1. Allow engine to cool down to room temperature before spraying the engine.
2. Thoroughly clean the entire engine using a steam cleaner or high pressure washer with mild soap and warm water.

**WARNING:*****EYE INJURY***

To avoid injury from flying debris when using compressed air, wear adequate eye protection (face shield or safety goggles) and do not exceed 276 kPa (40 psi) air pressure.

3. Once the engine is clean, blow the electrical connectors dry with compressed air to remove most of the standing water.
4. Allow the engine to dry completely before making any kind of repair.
5. When reassembling, ensure that there is no standing water in any electrical connectors before seating the plug.

14.01.09 Cleaning/Flushing the Cooling System

Collect the used coolant, cleaning solutions, and washing liquids and dispose of them in an environmentally responsible manner.

Degrease as follows:

**WARNING:*****HOT COOLANT***

To avoid scalding from the expulsion of hot coolant, never remove the cooling system pressure cap while the engine is at operating temperature. Wear adequate protective clothing (face shield, rubber gloves, apron, and boots). Remove the cap slowly to relieve pressure.

1. First remove debris (such as dust, insects) from the fins of the radiator grille.

**WARNING:*****EYE INJURY***

To avoid injury from flying debris when using compressed air, wear adequate eye protection (face shield or safety goggles) and do not exceed 276 kPa (40 psi) air pressure.

2. Remove the debris by blowing them through with compressed air or spraying them out with water. Work from the rear of the radiator (in the opposite direction of the normal cooling air flow).
3. Drain the coolant when the engine is cold. [Cooling System Drain Procedure](#). For detailed procedures, see the vehicle/chassis maintenance manual. For types of coolant, [Coolant Selections and Maintenance](#) for the listing of required intervals using the recommended coolants.
4. If the HVAC unit is connected to the cooling system, open the regulating valves all the way.
5. Fill the cooling system with a 5% solution (1.6 ounces per quart [50 grams per liter] of water) of a mildly alkaline cleaning agent. [Coolant Selections and Maintenance](#).

6. Run the engine at moderate speed until the thermostat starts to open. The thermostat starts to open at 88°C (190°F) and is fully open at 95°C (203°F). Then run it for about five minutes longer. Shut down the engine and allow it to cool to approximately 50°C (112°F).
7. Drain all the cleaning solution.
8. Flush the cleaning solution from the cooling system.
 - 8.a Immediately after draining the cleaning solution, flush the system with clean water.
 - 8.b Once the clean water has drained, fill the system again with clean water.
 - 8.c Run the engine at moderate speed until the thermostat starts to open. The thermostat starts to open at 88°C (190°F) and is fully open at 95°C (203°F). Then run it for about five minutes longer. Shut down the engine and allow it to cool to approximately 50°C (112°F).
 - 8.d Drain the hot water.
9. Fill the cooling system with new coolant. For detailed procedures, see the vehicle/chassis maintenance manual. For types of coolant, [Coolant Selections and Maintenance](#) for the listing of required intervals using the recommended coolants.

14.01.10 Coolant Selections and Maintenance

Coolant Selections and Maintenance

This section covers selection of the required coolant for the engine.

Extended Life Coolants

Extended Life Coolant (ELC) contain Organic Acid Technology (OAT) which provide corrosion protection and inhibit liner cavitation. These coolants require less maintenance over the useful life of the engine.

ELC antifreeze coolants are commercially available from Detroit™ (recommended) and other manufacturers as either concentrated or pre-mixed formulations. Concentrated antifreeze coolants should be mixed at 50% (50% antifreeze/50% water). All ELC's used must also meet DFS 93K217 specification. Detroit™ requires that these types of coolants to be free of nitrite and phosphate. Detroit™ has found that ELC's containing nitrite may lead to a breakdown of the coolant and subsequent damage to the cooling system.

These types of coolants should not be mixed with Standard Life Coolants. If an ELC antifreeze coolant and SLC antifreeze coolants are mixed, damage may not result, but the long-life advantages of the ELC antifreeze coolant will be lost. In this event, the coolant should be re-inhibited with OAT inhibitors and confirmed by analysis or else it must be maintained as an SLC antifreeze coolant.

SLC Antifreeze Coolants

Standard Life Coolant (SLC) contain inhibitor salts, including nitrites, to prevent liner cavitation. These coolants require interval testing to maintain inhibitor concentration.

SLC antifreeze coolants are commercially available from Detroit™ (recommended) and other manufacturers as either concentrated or as pre-mixed antifreeze. Concentrated antifreeze coolants should be mixed at 50% (50% antifreeze/50% water). All fully formulated coolants used must also meet DFS 93K217 specification.

NOTE: Fully formulated antifreeze does not require a dosage of Supplemental Coolant Additive (SCA) at initial use.

14.01.11 Coolant Fill Options

Coolant Fill Options

The coolants recommended for use in Detroit™ engines are listed in the tables below. This publication will give a complete explanation of their use.

NOTICE

Required specifications for water, Ethylene Glycol (EG), Propylene Glycol (PG), inhibitor packages, and inhibitor concentration are included in the appendix of this publication. To avoid possible engine damage from inadequate or over-concentrated coolant, this publication should be read thoroughly before replacing or topping-off coolant.

Engine Series	Coolant Factory Fill Options	Service Fill Options
DD5, DD8, DD13, DD15, DD16	Extended Life Coolant (ELC) - Organic Acid Technology (OAT)	Detroit Power Cool Plus or refer to 93K217 list of approved coolants at DTNAConnect.com
	Standard Life Coolant (SLC) - Conventional	Detroit Power Cool or refer to 93K217 list of approved coolants at DTNAConnect.com

Table 1, DD5, DD8, DD13, DD15, and DD16 Coolant Fill Options

Engine Series	Coolant Fill Options	Service Fill Options
Series 50, Series 55, Series 60, MBE900, MBE4000	Ethylene Glycol based antifreeze coolant + SLC corrosion inhibitors	Detroit Power Cool or refer to 93K217 list of approved coolants at DTNAConnect.com
	Propylene Glycol based antifreeze coolant + SLC corrosion inhibitors	No Detroit™ product available. Refer to 93K217 list of approved coolants at DTNAConnect.com
	Water based coolant + SLC corrosion inhibitors ¹	Deionized Water + Detroit Genuine Coolant 3000
	Ethylene Glycol based antifreeze coolant + ELC inhibitors	Detroit Power Cool Plus or refer to 93K217 list of approved coolants at DTNAConnect.com
	Propylene Glycol based antifreeze coolant + ELC inhibitors	No Detroit™ product available. Refer to 93K217 list of approved coolants at DTNAConnect.com
	Water based coolant + ELC inhibitors ¹	Deionized Water + Detroit Genuine Coolant Plus 6000

¹ Water-only coolant systems offer no freeze protection and should not be used where ambient temperatures can fall to 0°C (32°F).

Table 2, Legacy Engine Coolant Fill Options

Engine Series	Coolant Factory Fill Options	Service Fill Options
DD8	Silicated Organic Acid technology (Si-OAT)	Refer to 93K217 list of approved coolants at DTNAConnect.com.

Table 3, Freightliner EconicSD Coolant Fill Options

Additional approved coolant products can be found on the Detroit 93K217 list at the DTNA Portal.

14.01.12 Coolant Do's and Don'ts

Coolants for Detroit™ Engines

The intent of this bulletin is to provide the requirements, directions, and information required to ensure cooling system protection for Detroit™ engines. These recommendations are general rules and reflect years of experience, technology research, and product development. Specific concerns not covered by this publication should be addressed to your local Detroit™ representative. The coolant used in Detroit™ engines must meet **DFS 93K217 Specification** with the following basic requirements:

- Provide an adequate heat transfer medium.
- Protect against cavitation damage to both cylinder liners and water pumps.
- Provide a corrosion/erosion-resistant environment.
- Prevent formation of scale or sludge deposits.
- Be compatible with cooling system hose and seal materials.
- Provide adequate freeze protection.

The rest of this section will describe the requirements for the proper usage of the water, antifreeze, and corrosion inhibitors. It will also describe the coolants and additives that are not recommended by Detroit™ and have been proven harmful to Detroit™ engines.

Coolants NOT Permitted

The following coolants are not to be used in Detroit™ engines:

- **Automotive/Passenger car-type coolants** must not be used in Detroit™ engines because they offer no liner pitting protection. Also, these types of coolants generally contain high levels of phosphates and silicates.
- **Methyl alcohol-based antifreeze** must not be used in Detroit™ engines because of its effects on the nonmetallic components of the cooling system and its low boiling point.
- **Methoxy propanol-based antifreeze** must not be used in Detroit™ engines because it is not compatible with fluorocarbon elastomer seals found in the cooling system.
- **Glycol-based coolants formulated for Heating/Ventilation/Air Conditioning (HVAC)** must not be used in Detroit™ engines. These coolants generally contain high levels of phosphates, which will form deposits on hot internal engine surfaces, reduce heat transfer, and cause water pump seal leaks.
- **Waterless-type coolants** must not be used.
- **Nitrite Organic Acid Technology (NOAT)** must **not** be used in Detroit™ engines because with poor maintenance components become more vulnerable.

Non-Formulated Additives NOT Permitted

The following additives should not be used in Detroit™ engines:

- **Soluble Oils:** Soluble oil additives are not approved for use in Detroit™ engine cooling systems. A small amount of oil adversely affects heat transfer. For example, a 1.25% concentration of soluble oil increases the fire deck temperature 6%. A 2.50% concentration increases the fire deck temperature 15%. The use of soluble oil additives may result in engine overheating and/or failure.
- **Chromates:** Chromate additives are not approved for use in Detroit™ engine cooling systems. Chromate additives can form chromium hydroxide, commonly called "green slime." This, in turn, can result in engine damage due to poor heat transfer. Cooling systems operated with a chromate-inhibited coolant must be chemically cleaned with Detroit™ Genuine Coolant **Twin Pack** cooling system cleaner/conditioner (or equivalent sulfamic acid/sodium carbonate cleaner) and flushed.
- **Phosphate Inhibitors:** Phosphate has tendency to form deposits on surfaces transferring high heat which ultimately affect cooling capabilities. Phosphate deposits on water pump seals will result in coolant leakage across seal faces.

14.01.13 Maintenance

Topping Off Coolant

NOTE: Topping off must be done while the vehicle is off and has had time to cool down. Topping off should never be done on a warm engine or a running vehicle.

The coolant level should be checked daily and at each service interval. If topping off is necessary, add coolant which is identical to the initial-fill coolant. Extended Life Coolants (ELC) also known as Organic Acid Technology Coolants (OAT) should be topped-off with a coolant of the same formulation; Standard Life Coolants (SLC) also known as Conventional should also be topped-off with a coolant of the same formulation.

Silicated Organic Acid technology (Si-OAT) should only be topped off with Silicated Organic Acid technology (Si-OAT) listed on DFS 93K217. Do not mix with other coolants even if they are the same color.

Coolant Maintenance Intervals

The following tables contain the coolant maintenance intervals.

Silicated Organic Acid Technology (Si-OAT) Coolant Additive Maintenance Procedures

Detroit™ recommends following the manufacturer's recommendations as to minimum and maximum limits.

Freeze Point Check

To best measure the quality of anti-freeze coolant, a check of the freeze point (glycol concentration), by refractometer, should be performed at each service interval to ensure anti-freeze levels are within specification. Detroit™ requires a freeze point between -31°C and -42°C (-24°F and -44°F) to guarantee optimal engine protection. The exception would be certain regions that require a freeze point of (-51°C) -60°F to protect against colder climates.

Laboratory Testing

Laboratory testing is the best practice for determining Silicated Organic Acid technology (Si-OAT) coolant quality and will provide vital information regarding the engine performance.

Standard Life Coolant Additive Maintenance Procedures

The concentrations of SLC inhibitors will gradually deplete during normal engine operation. SCAs replenish the protection for cooling system components and must be added to the cooling system on an as needed basis. Below are test procedures that will assist in determining the inhibitor concentration.

[Coolant Test Procedure](#)

3-Way Test Strips

Nitrite concentration is an indication of the overall coolant inhibitor concentration in SLC formulations. These coolants must be tested for nitrite concentration at the regular intervals as listed in Table "Standard Life Coolant". Detroit™ Genuine Fluid Analysis 3-Way Test Strips (or equivalent) are recommended. Use these test strips to measure nitrite and glycol concentrations. Cavitation/corrosion protection is indicated on the strip by the level of nitrite concentration. Freeze/boil-over protection is determined by glycol concentration.

Laboratory Testing

As an alternative to the test strips, a factory coolant analysis program is available through authorized Detroit™ service outlets. To verify coolant acceptability, submit a sample for coolant analysis according to Table "Standard Life Coolant".

Standard Life Coolant Maintenance Intervals

Service Application	Efficient Long Haul ¹	Long Haul ²	Short Haul ³	Severe ⁴	Action Required
Engine Series					
Series 40, 50, 60	Not Applicable	Every 30,000 miles (48,000 km) or 1 year ⁵	Every 20,000 miles (32,000 km) or 500h, or 6 months ⁵	Every 15,000 miles (24,000 km) or 300h, or 3 months ⁵	Standard Life Coolant Additive Maintenance Procedures
MBE4000, MBE900	Not Applicable	Every 30,000 miles (48,000 km) or 1 year ⁵	Every 15,000 miles (24,000 km) or 500h, or 6 months ⁵	Every 10,000 miles (16,000 km) or 300h, or 3 months ⁵	
DD13	65,000 miles (105,000 km)	55,000 miles (89,000 km) or 1 year ⁵	40,000 miles (64,000 km), 895 hours or 1 year ⁵	35,000 miles (56,000 km), 640 hours or 6 months ⁵	

Table 5, Standard Life Coolant (also known as Conventional) Maintenance Intervals:

Service Application	Efficient Long Haul ¹	Long Haul ²	Short Haul ³	Severe ⁴	Action Required
Engine Series					
DD15	75,000 miles (121,000 km)	60,000 miles (97,000 km) or 1 year ⁵	45,000 miles (72,000 km), 895 hours or 1 year ⁵	35,000 miles (56,000 km), 640 hours or 6 months ⁵	
DD16	Not Applicable	55,000 miles (89,000 km) or 1 year ⁵	40,000 miles (64,000 km), 895 hours or 1 year ⁵	35,000 miles (56,000 km), 640 hours or 6 months ⁵	

1. Efficient Long Haul (over-the-road transport) service applies to vehicles that annually travel more than 60,000 miles (96,000 kilometers) and average greater than 7 miles per gallon with minimal city stop-and-go operation and minimum idle.

2. Long Haul (over-the-road transport) service applies to vehicles that annually travel more than 60,000 miles (96,000 kilometers) and average greater than 6 miles per gallon with minimal city stop-and-go operation.

3. Short Haul service applies to vehicles that annually travel up to 30,000 to 60,000 miles (48,000 to 96,000 km) and average between 5.1 and 5.9 miles per gallon.

4. Severe service applies to vehicles that annually travel up to 30,000 miles (48,000 km) and average less than 5 miles per gallon or that operate under severe conditions. Severe service also applies to RV applications. Service applies to vehicles that annually travel up to 30,000 miles (48,000 km) or that operate under severe conditions. Only one of these conditions needs be met to categorize an application as Severe Service.

5. Whichever comes first.

Table 4, Standard Life Coolant (also known as Conventional) Maintenance Intervals:

Service Application	Efficient Long Haul ¹	Long Haul ²	Short Haul ³	Severe ⁴	Action Required
Engine Series					
DD5	Not Applicable	Every 50,000 miles (80,000 km) or 1 year ⁵	Every 45,000 miles (72,000 km) or 3,000 hrs, or 1 year ⁵	Every 35,000 miles (56,000 km) or 1,000 hrs, or 1 year ⁵	Standard Life Coolant Additive Maintenance Procedures

1. Efficient Long Haul is not applicable to the DD5 engine.

2. Long Haul service (over-the-road transport) applies to vehicles that annually travel more than 60,000 miles (96,000 km) and average greater than 12.0 miles per gallon with minimal city stop-and-go operation. Examples of Long Haul service are: regional delivery that is mostly freeway mileage, interstate transport, and any road operation with high annual mileage.

3. Short Haul service applies to vehicles that annually travel up to 60,000 miles (96,000 km) and average between 10.1 and 11.9 miles per gallon and operate under normal conditions. Examples of Short Haul service are: operation primarily in cities and densely populated areas, local transport with infrequent freeway travel, or a high percentage of stop-and-go travel.

4. Severe service applies to vehicles that average below 10.0 miles per gallon or that operate under severe conditions. Examples of Severe Service are: idle time over 40%, load factor over 55%, operation on extremely poor roads or under heavy dust accumulation; constant exposure to extreme hot, cold, salt-air, or other extreme climates; frequent short-distance travel; construction-site operation; or farm operation. Only one of these conditions needs be met to categorize an application as Severe Service.

5. Whichever comes first.

Table 5, Standard Life Coolant (also known as Conventional) Maintenance Intervals:

Service Application	Efficient Long Haul ¹	Long Haul ²	Short Haul ³	Severe ⁴	Action Required
Engine Series					
DD8	Not Applicable	Every 60,000 miles (96,000 km) or 2,000 hrs or 1 year ⁵	Every 55,000 miles (88,000 km) or 1,800 hrs, or 1 year ⁵	Every 45,000 miles (72,000 km) or 1,500 hrs, or 1 year ⁵	Standard Life Coolant Additive Maintenance Procedures

1. Efficient Long Haul is not applicable to the DD8 engine.

2. Long Haul service (over-the-road transport) applies to vehicles that annually travel more than 60,000 miles (96,000 km) and average greater than 8.5 miles per gallon with minimal city stop-and-go operation. Examples of Long Haul service are: regional delivery that is mostly freeway mileage, interstate transport, and any road operation with high annual mileage.

3. Short Haul service applies to vehicles that annually travel up to 60,000 miles (96,000 km) and average between 6.5 and 8.5 miles per gallon and operate under normal conditions. Examples of Short Haul service are: operation primarily in cities and densely populated areas, local transport with infrequent freeway travel, or a high percentage of stop-and-go travel.

4. Severe service applies to vehicles that average below 10.0 miles per gallon or that operate under severe conditions. Examples of Severe Service are: idle time over 40%, load factor over 55%, operation on extremely poor roads or under heavy dust accumulation; constant exposure to extreme hot, cold, salt-air, or other extreme climates; frequent short-distance travel; construction-site operation; or farm operation. Only one of these conditions needs be met to categorize an application as Severe Service.

5. Whichever comes first.

Table 6, Standard Life Coolant (also known as Conventional) Maintenance Intervals:

Engine Series	SLC
Series 60, 50, 40	300,000 miles (482,800 km) or 2 years
MBE4000, MBE900	
DD5, DD8, DD13, DD15, DD16	

Table 7, Standard Life Coolant (also known as Conventional) Drain Intervals:

Supplemental Coolant Additives (SCA)

Supplemental Coolant Additive (SCA) Solutions- for Ethylene or Propylene Glycol-based Antifreeze Coolants

The coolant must be maintained with the proper concentration of corrosion inhibitors. As the concentration of inhibitors deplete, additional SCA must be added to the coolant as indicated by a nitrite concentration of 900 PPM, or less. If the nitrite concentration is greater than 900 PPM, do not add additional SCA. If the nitrite concentration is above 3200 PPM, the system is over-inhibited. The system should be partially drained and filled with a 50/50 mix of water and EG or PG.

Supplemental Coolant Additive (SCA) Solutions - for Water-based Coolants (Legacy Engines Only)

In warm climates where freeze protection is not required, water only with corrosion inhibitors is approved for use. Water-only systems need to be treated with the proper dosage of corrosion inhibitors. Detroit™ approved conventional SCA or OAT corrosion inhibitors must be added to the water to provide required corrosion and cavitation erosion protection.

Need-Release Coolant Filters (STANDARD LIFE COOLANT ONLY¹)

Need-Release coolant filters are available for Series 50, Series 60 and pre-2016 DD series engines. Membranes in the filters release SCAs before the coolant approaches a corrosive condition, protecting the engine from corrosion. The need-release elements release the SCA charge as needed, as opposed to the maintenance SCA elements, which instantaneously release the SCA charge. Need-release coolant filter elements should be replaced after one year or 100,000 miles (160,000 km), or 3,000 operating hours, whichever comes first.

1. Need-Release filters are not to be used with ELC type coolants. Such use will cause serious damage to the engine.

14.01.14 Appendix A - Definitions

Appendix A - Definitions

Antifreeze:

A substance that is added to the water in a vehicle's cooling system that lowers the freeze point to prevent freezing. The two most common antifreezes are ethylene glycol (EG) and propylene glycol (PG).

Coolant:

A fluid that transfers heat from the engine by circulation.

Extended Life Coolant (ELC): AKA - Long-Life Coolant or Organic Acid Technology:

These types of coolants have been formulated to extend the service interval of the coolant. Example of ELC is Power Cool Plus.

Fully Formulated:

Antifreeze that contains all the necessary inhibitors to protect a diesel engine and does not, therefore, require a pre-charge of Supplemental Coolant Additive before its first use.

Initial-Fill:

The coolant that is used in a new or rebuilt engine, or used any time the cooling system is emptied and then refilled with new coolant.

Standard Life Coolant (SLC): AKA - Fully-Formulated or Conventional Coolant:

These types of coolants use supplemental coolant additives (SCA) to protect against corrosion or mechanical wear. Example of SLC is Power Cool.

Supplemental Coolant Additive:

An additive used in a preventive maintenance program to prevent corrosion, cavitation, and the formation of deposits.

14.01.15 Appendix B - General Coolant Information

Appendix B - General Coolant Information

SLC Antifreeze Coolants

These products are available as Fully Formulated and Phosphate-Free. They are commercially available from Detroit™ (recommended) and other manufacturers as either concentrated antifreeze or as pre-mixed antifreeze. The pre-mixed antifreeze is ready to use, while the concentrated coolant must be mixed with water prior to use. All fully formulated coolants used must also meet Detroit 93K217 specification.

NOTE: Fully formulated antifreeze does not require a dosage of Supplemental Coolant Additive (SCA) at initial use.

ELC Antifreeze Coolants

EG and PG based antifreeze coolants contain Organic Acid Technology (OAT). These coolants require less maintenance over the useful life of the engine.

ELC antifreeze coolants are available as either concentrated or pre-mixed formulations. Concentrated antifreeze coolants should be mixed at 50% (50% antifreeze/50% water). **These types of coolants should not be mixed with SLCs.** If an ELC antifreeze coolant and SLC antifreeze coolants are mixed, damage may not result, but the long-life advantages of the ELC antifreeze coolant will be lost. In this event, the coolant should be re-inhibited with OAT inhibitors and confirmed by analysis or else it must be maintained as an SLC antifreeze coolant.

Water-Only Coolants (Series 50, 55 and 60 only)

In warm climates where freeze protection is not required, water only with corrosion inhibitors is approved for use. Water-only systems need to be treated with the proper dosage of corrosion inhibitors. Detroit™-approved SCA or ELC corrosion inhibitors must be added to the water to provide required corrosion and cavitation erosion protection.

Mixing Ethylene Glycol or Propylene Glycol Antifreeze and Water

It is highly recommended to use a pre-mixed 50/50 antifreeze coolant. However, if a concentrated Ethylene Glycol or Propylene Glycol antifreeze is purchased, mix the antifreeze with water meeting the required quality standards and fill the cooling system. See water requirement below for quality standards. If a pre-diluted coolant is purchased, simply fill the cooling system.

For best overall performance, a coolant consisting of 50% concentration of antifreeze (50% antifreeze, 50% water) is recommended. An antifreeze concentration of over 60% (60% antifreeze, 40% water) is **not recommended** due to poor heat transfer, reduced freeze protection, and possible silicate dropout. An antifreeze concentration below 40% (40% antifreeze, 60% water) offers too little freeze and/or corrosion protection and is **not recommended**.

WATER REQUIREMENTS

Distilled or de-ionized water, which eliminates the adverse effects of minerals in tap water, is preferred. High levels of dissolved chlorides, sulfates, magnesium, and calcium in some tap water causes scale deposits, sludge deposits and/or corrosion. These deposits have been shown to result in water pump failures and poor heat transfer, resulting in overheating. If tap water is used, the mineral content in the water must be below the maximum concentration listed in the table below.

Minerals	Maximum Concentration	
	Parts per Million	Grains per Gallon
Chlorides	40	2.5
Sulfates	100	5.8
Total Dissolved Solids	340	20
Magnesium + Calcium Content	170	10

Table 8, Maximum Mineral Concentration in Water

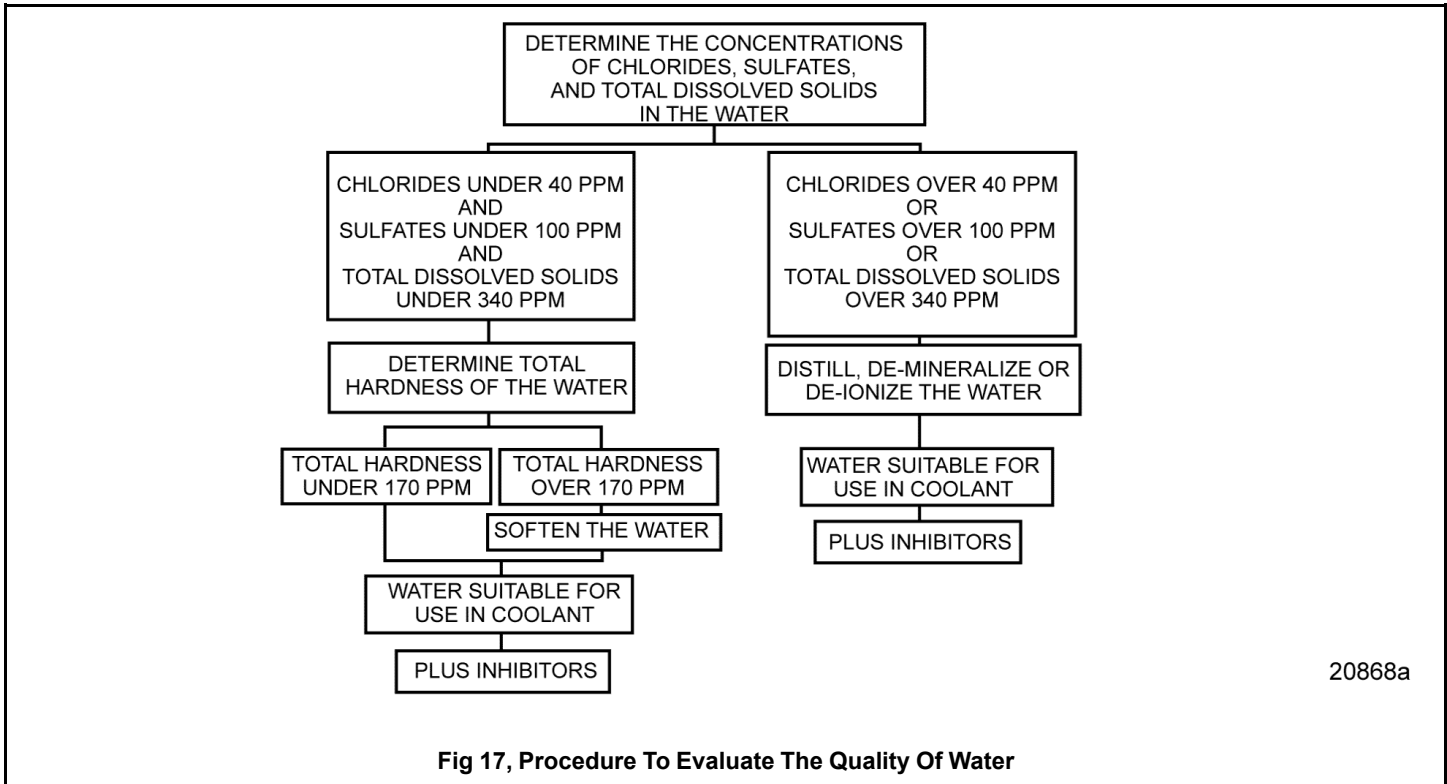

Recycled Antifreeze

Antifreeze coolant made with ethylene or propylene glycol recycled by reverse osmosis, distillation, and ion exchange and properly re-inhibited to meet ASTM D6471 or D6472 requirements has been demonstrated to provide service equivalent to virgin antifreeze. Recycled antifreeze coolants of these types are preferred. However, suppliers of these recycled glycols must provide evidence the product is free of contaminants listed below:

- Acetates
- Acetone
- Ammonia
- Boron
- Ethanol
- Formates
- Glycolates
- Ketones
- Nitrate
- Nitrite
- Phenols
- Phosphorus
- Silicon
- Toluene

Other recycled coolants, especially coolants recycled through filtration processes, are **not recommended**.

14.01.16 Appendix C - Detroit™ Cooling System Maintenance Products

Appendix C - Detroit™ Cooling System Maintenance Products

Coolant Type	Part Number	Description
Concentrate	OWI 23539616	One Gallon Jug - 4 Per Case (Canada)
	OWI 23519397	One Gallon Jug - 6 Per Case
	OWI 23519394	55-Gallon Drum
Pre-Diluted (50:50)	OWI 2359617	One Gallon Jug - 4 Per Case (Canada)
	OWI 23519396	One Gallon Jug - 6 Per Case
	OWI 23519398	55-Gallon Drum
	OWI 2359084	275-Gallon Tote (Canada)

Table 9, Detroit™ Extended Life Coolant (Ethylene Glycol-based)

Coolant Type	Part Number	Description
IEG Detroit™ Genuine Coolant; Series 50 and Series 60	OWI 23519400	One Quart Bottle - 6 Per Case

Table 10, Detroit Genuine Coolant Plus Extender (for use with Detroit Genuine Coolant Plus)

Coolant Type	Part Number	Description
Concentrate	OWI 23539622	One Gallon Jug - 4 Per Case (Canada)
	OWI 23512138	One Gallon Jug - 6 Per Case
	OWI 23512139	55-Gallon Drum
	OWI 23513503	Bulk Delivery - 1000 Gallon min.
Pre-Diluted (50:50)	OWI 23539623	One Gallon Jug - 4 Per Case (Canada)
	OWI 23528203	One Gallon Jug - 6 Per Case
	OWI 23518918	55-Gallon Drum
	OWI 23538603	275-Gallon Tote

Table 11, Detroit™ Standard Life Coolant (Ethylene Glycol-based)

Coolant Type	Part Number	Description
IEG Detroit™ Genuine Coolant	PIC 23507858	Pint Bottle - 12 Per Case
	PIC 23507860	5-Gallon Pail
	PIC 23507861	55-Gallon Drum

Table 12, Detroit™ Genuine Coolant 2000 Supplemental Coolant Additives (SCA)

Coolant Type	Part Number	Description
IEG Detroit™ Genuine Coolant	PIC 23507854	Pint Bottle - 12 Per Case
	PIC 23507855	Half Gallon Jugs - 6 Per Case
	PIC 23507856	5-Gallon Pail
	PIC 23507857	55-Gallon Drum

Table 13, Detroit™ Genuine Coolant 3000 SCAs

Coolant Type	Part Number	Description
IEG Detroit™ Genuine Coolant	23507545	4 Ounce (1 Pint Equivalent)
	23508425	8 Ounce (2 Pint Equivalent)
	23508426	12 Ounce (3 Pint Equivalent)
	23507189	16 Ounce (4 Pint Equivalent)
	23508427	32 Ounce (8 Pint Equivalent)
	23508428	53 Ounce (13 Pint Equivalent)

Table 14, Detroit Genuine Coolant 3000 SCA Filters (Series 50 and Series 60 Engines Only)

Coolant Type	Part Number	Description
All Types	PIC 201549	Twin pack - 2 Per Case
Standard Life Coolant Only	PIC 200164	One-Half Gallon Jug - 6 Per Case
	PIC 200105	5-Gallon Pail
	PIC 200155	55-Gallon Drum

Table 15, Detroit Genuine Coolant Cooling System Cleaners

Coolant Type	Part Number	Description
Standard Life Coolant	DDE 23516921	U.S. SLC Test Kit
Extended Life Coolant	DDE 23539088	U.S. ELC Test Kit

Table 16, Detroit Genuine Fluid Analysis Products

14.01.17 Checking the Hoses

Check the hoses as follows:

1. Inspect the cooling system hoses and replace any hose that shows obvious signs of damage or feels abnormally soft or hard.
2. Replace damaged clamps.
3. Correct all external leaks as soon as detected.
4. Check coolant inhibitor levels at the intervals listed in this manual.

Current engine designs no longer use coolant filters. If you have a coolant filter, you may choose to remove the filter at your next maintenance interval. For more details reference bulletin 15TS-10Rev.

14.01.18 How to Service the Dry Type Air Cleaner

Maintain the air cleaner as follows:

1. Replace dry type air cleaner elements when the maximum allowable air cleaner restriction has been reached. Air cleaners are equipped with a restriction indicator which aids in determining the servicing interval.
2. Do not clean and/or reuse a dry paper-type air cleaner.

15.01 Customer Assistance.....	126
15.01.01 Availability of Detroit™ Service Outlets	126

15. Customer Assistance

15.01 Customer Assistance

The satisfaction and goodwill of the owners of Detroit™ engines are of primary concern to Detroit™ and its distributor/dealer organizations. Contact the Regional Support Center.

15.01.01 Availability of Detroit™ Service Outlets

As the owner of a Detroit™ product, you have a complete network of Detroit™ service outlets in Latin America, plus many outlets worldwide that are prepared to meet your parts and service needs:

- Service by trained personnel
- Sales team to help determine your specific power requirements
- In many areas, emergency service 24 hours a day
- Complete parts support
- Product information and literature

We recognize however, that despite the best intentions of everyone concerned, misunderstandings may occur. Normally, any situation that arises in connection with the sale, operation or service of your product will be handled by the authorized service outlet in your area (in Latin America, check the service locator at www.demanddetroit.com for Detroit™ service outlet nearest you).

16.01 Detroit Genuine Coolant Engine Products	128
16.02 Engine Oil Capacities - EuroV	129

16. Specifications

16.01 Detroit Genuine Coolant Engine Products

Maintenance of the cooling system requires the chemical makeup of the system to be balanced.

Detroit Genuine Fully Formulated Inhibited Ethylene Glycol Coolants

The part numbers and sizes of concentrated and pre-blended 50:50 Detroit Genuine Coolants are listed in the following Tables.

Coolant Type	Part Number	Description
Concentrated	23512138	One Gallon Jug – 6 Per Case
	23512139	55 Gallon Drum
	23529295	330 Gallon Tote
	23512140	Bulk Delivery – 1,000 Gallon Min.
Pre-blended 50:50	23528203	One Gallon Jug – 6 Per Case
	23518918	55 Gallon Drum
	23528544	330 Gallon Tote
	23513503	Bulk Delivery – 1,000 Gallon Min.

Detroit Genuine Supplemental Coolant Additive Need Release Filters

Detroit Genuine Supplemental Coolant Additive Need Release Filters are shown below.

Coolant Type	Part Number	Description
Detroit Genuine Inhibited Ethylene Glycol Coolant	NF2091	For 0 – 8 Gallon Systems
	23516489	For 8 – 20 Gallon Systems

Detroit Genuine Cooling System Cleaners

Detroit Genuine Cooling System Cleaners are shown below.

Coolant Type	Part Number	Description
On-Line Cleaner	200164	One-Half Gallon Jug – 6 Per Case
	200105	5 Gallon Pail
	200155	55 Gallon Drum
Twin Pack	201549	Twin Pack – 2 Per Case

Detroit Genuine Fluid Analysis Products

Detroit Genuine Fluid Analysis Products are shown below.

Application	Part Number	Description
Indicates Nitrite, Molybdate & Glycol Levels	23519401	3-Way Coolant Test Strips (Single Foil Packs)
Indicates Nitrite, Molybdate & Glycol Levels	23519402	3-Way Coolant Test Strips (Bottle of 50)
Indicates Nitrite, Molybdate & Glycol Levels	23522774	3-Way Coolant Test Strips (Bottle of 10)
Complete Inhibited Ethylene Glycol Coolant Analysis	23516921	Coolant Analysis Bottle (Carton of 6)
Organic Coolant Analysis	23539088	Laboratory Coolant Analysis

16.02 Engine Oil Capacities - EuroV

Consult with a Detroit distributor to obtain the proper engine oil filters.

The engine oil capacities for the DD Platform Engine On-Highway Vehicle application are listed in the following tables. Contact your local Detroit service center if you need more specific information.

NOTE: There are approximately 5.0 L (5.2 qts) of oil represented from the fill mark to the full mark.

NOTICE

Overfilling the oil pan can cause engine damage.

Parameter	DD13 Truck	DD13 Coach	DD16 Truck
Service Fill (Oil and Filter Change)	38.0 L (40.0 qt)	45.0 L (48.0 qt)	43.0 L (45.0 qt)
Oil Pan Capacity, High Limit	35.0 L (37.0 qt)	42.0 L (44.0 qt)	40.0 L (42.0 qt)
Oil Pan Capacity, Low Limit	30.0 L (32.0 qt)	37.0 L (39.0 qt)	35.0 L (37.0 qt)

CONTACT INFORMATION

For questions, please create a Service Technical Request using the DTTS Application on the DTNA Portal.