



eM2 Driver's Manual

Models: eM2

Table of Contents

1. Foreword.....	5
2. Electric Vehicle Quick Start Guide	9
3. Vehicle Identification	11
4. Vehicle Access	23
5. Instruments	35
6. Driver Controls	69
7. Detroit Assurance	85
8. Driver Assistance Features	109
9. Seats and Restraints	113
10. Cab Features	131
11. Electrical System.....	143
12. Vehicle Charging, Operation, and Shutdown	159
13. Brake Systems	195
14. Steering System	211
15. eAxle	215
16. Headlight Aiming.....	221
17. Vehicle Appearance and Care.....	227
18. Pre- and Post-Trip Checklists.....	235
19. Pre- and Post-Trip Inspections and Maintenance.....	241
20. In An Emergency	259
21. Emissions Information	287
22. Telematics Information.....	291

1.01 Customer Assistance Center.....	6
1.02 Environmental Concerns and Recommendations	6
1.03 Data Logging	6
1.04 Emissions and Energy Efficiency Compliance	6
1.05 Reporting Safety Defects	6

1. Foreword

1.01 Customer Assistance Center

Having trouble finding service? Call the Customer Assistance Center at 1-800-385-4357 or 1-800-FTL-HELP. For dealer referrals and breakdown support, call night or day, weekdays or weekends. For specification requests and all other concerns and inquiries, the Customer Assistance Center is available 5:00 A.M. to 4:00 P.M. PST Monday through Friday. Our people are knowledgeable, professional, and committed to following through to help you keep your truck moving.

1.02 Environmental Concerns and Recommendations

Whenever you see instructions in this manual to discard materials, you should first attempt to reclaim and recycle them. To preserve our environment, follow appropriate environmental rules and regulations when disposing of materials.

1.03 Data Logging

This vehicle is equipped with a control module that performs data logging capabilities.

This vehicle is equipped with one or more devices that record specific vehicle data and may perform some of the same functionality as a regulated Event Data Recorder but the device(s) are not subject to, nor designed pursuant to, 49 C.F.R. Part 563.

The type and amount of data recorded varies depending on how the vehicle is equipped (such as the brand of engine, if an air bag is installed, or if the vehicle features a collision avoidance system, etc.). GPS location data, fault codes, and other technical data may be recorded.

This data may help provide a better understanding of the circumstances of a crash.

Personal data such as name, gender, and age are not recorded. However, other parties such as law enforcement, could combine the data logger's contents with the type of personally identifying data routinely acquired during a crash investigation.

1.04 Emissions and Energy Efficiency Compliance

This vehicle must be regularly inspected and maintained as indicated in the **Business Class eM2 Maintenance Manual**, and in the **Pre- and Post-Trip Inspections and Maintenance** chapter in this manual, in order to continue satisfactory performance and ensure coverage of the vehicle under the manufacturer's warranty.

Many maintenance procedures ensure that the vehicle continues to comply with applicable emissions and energy efficiency standards. Maintenance procedures, using components engineered to comply with energy efficiency regulations, may be performed by an authorized Daimler Truck North America dealer, an independent outlet, or the vehicle owner or operator.

The vehicle owner is responsible for determining the suitability of replacement components to maintain compliance with federal and local jurisdictional regulations. Components including, but not limited to, tires, cab/sleeper side extenders, chassis fairings, bumper, hood, and vehicle speed limiters are specifically designed and manufactured to exacting standards for regulatory energy efficiency. It is important that these components are always replaced with components that meet or exceed the performance of the originally installed components.

1.05 Reporting Safety Defects

Vehicles domiciled in the USA thought to have a defect that could cause a crash, injury, or death, should immediately be reported to the National Highway Traffic Safety Administration (NHTSA) and Daimler Truck North America LLC.

If the NHTSA receives similar complaints, it may open an investigation; if it finds that a safety defect exists in a group of vehicles, it may order a recall and remedy campaign. However, NHTSA cannot become involved in individual problems between you, your dealer, or Daimler Truck North America LLC.

To contact NHTSA, call the Vehicle Safety Hotline toll-free at 1-888-327-4236 (TTY: 1-800-424-9153).

To e-mail NHTSA, go to www.safertruck.gov/.

You can contact NHTSA by mail at: Administrator, NHTSA Headquarters, 1200 New Jersey Avenue SE, West Building, Washington, DC 20590.

For more information about motor vehicle safety, go to www.safertruck.gov/.

To contact Freightliner about a concern about a specific vehicle call the Customer Assistance Center at 1-800-385-4357 or complete a Product Concern Form.

Vehicles domiciled in Canada thought to have a defect that could cause a crash, injury, or death, should immediately be reported to Transport Canada and Daimler Truck North America LLC.

If Transport Canada receives similar complaints, it may open an investigation; if it finds that a safety defect exists in a group of vehicles, it may order a recall and remedy campaign. However, Transport Canada cannot become involved in individual problems between you, your dealer, or Daimler Truck North America LLC.

To contact Freightliner about a concern about a specific vehicle call the Customer Assistance Center at 1-800-385-4357 or complete a Product Concern Form.

To contact Transport Canada, call the Defect Investigations and Recalls Division toll-free in Canada at 1-800-333-0510 or 819-994-3328 in the Gatineau-Ottawa area or internationally.

You can also contact Transport Canada by mail at: Transport Canada, 330 Sparks Street, Ottawa, Ontario, K1A 0N5 Canada.

The following websites contain more information on Canadian recalls:

English: www.tc.gc.ca/recalls.

French: www.tc.gc.ca/rappels.

For additional road safety information, please visit the Road Transportation website:

English: www.tc.gc.ca/en/services/road

French: www.tc.gc.ca/fr/services/routier

2.01 Electric Vehicle Quick Start Guide 10

2. Electric Vehicle Quick Start Guide

2.01 Electric Vehicle Quick Start Guide

Information from this driver's manual has been pulled into an easy-to-reference quick start guide, focusing on electric vehicle operation and functionality. Scan the QR code below or follow this link to the [About this Quick Start Guide](#).



3.01 Component Information Label	12
3.02 Component Gross Vehicle Weight Rating Label	13
3.03 Federal Motor Vehicle Safety Standard Label	14
3.04 Canada Certification Label	16
3.05 Emissions Labels	17
3.05.01 Vehicle Emission Control Information Label	17
3.05.02 Noise Emission Control Labels.....	19
3.06 Customer Assistance Label.....	21

3. Vehicle Identification

3.01 Component Information Label

NOTE: Labels shown in this chapter are examples only. Actual specifications may vary from vehicle to vehicle.

A component information label, as shown, see Fig.2, [Component Information Label](#), lists the vehicle model, identification number, and major component models and serial numbers.

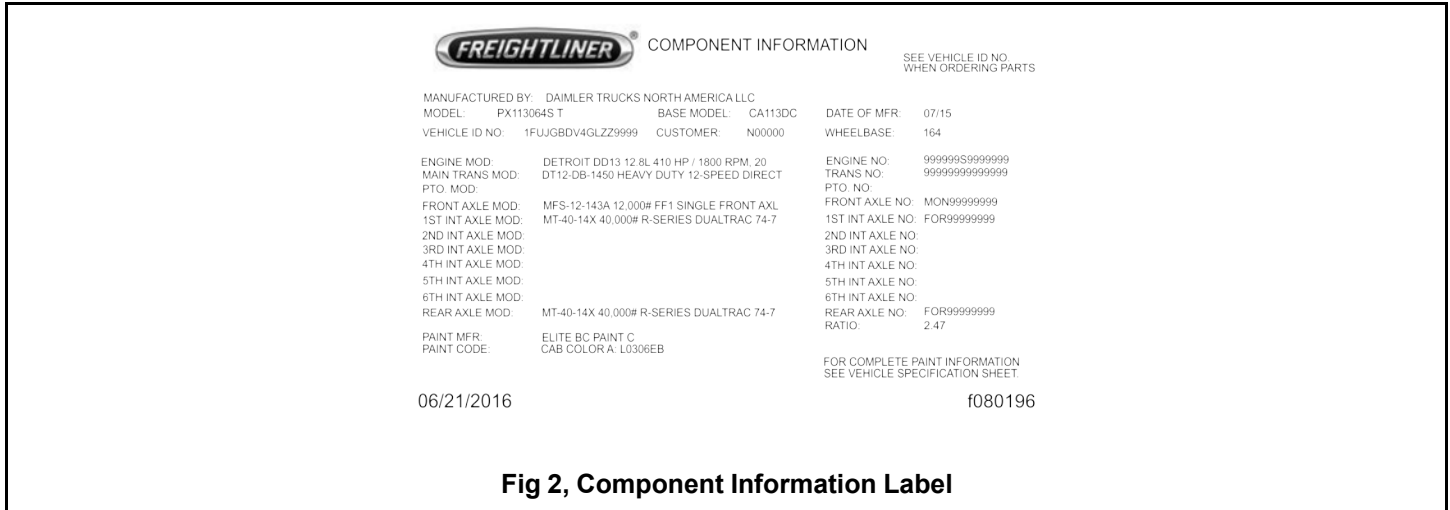

Fig 2, Component Information Label

The component information label is attached to the outside of the ziplock document bag and the right-hand door. See Fig. 3, [Component Information Label Location](#) for label location.

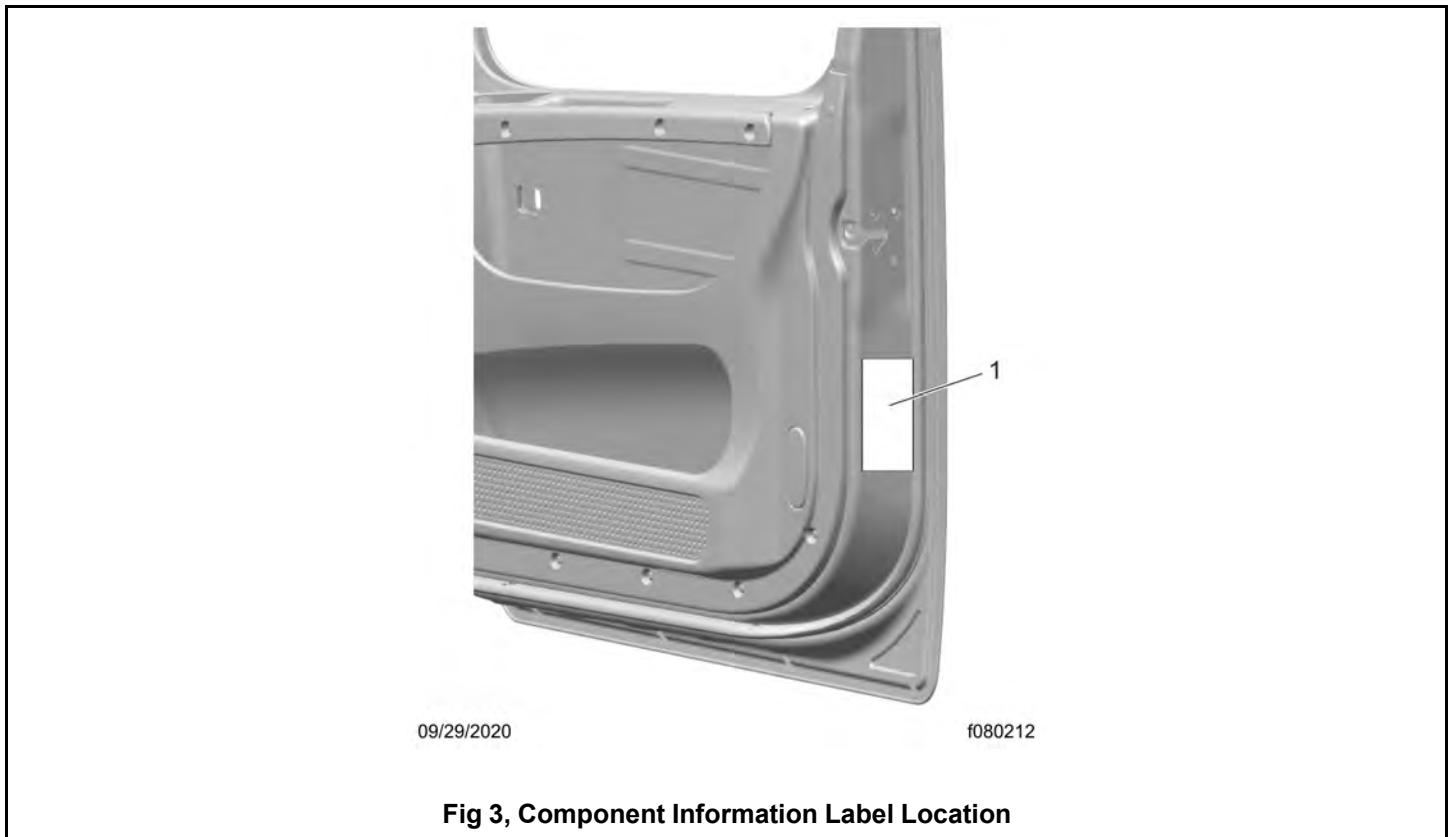

Fig 3, Component Information Label Location

3.02 Component Gross Vehicle Weight Rating Label

NOTE: Vehicles manufactured for the Canada market will have a Canada Certification label instead of a component gross vehicle weight rating (GWR) label.

A component GWR label, as shown, see Fig.4, [Component GWR Label](#), provides maximum GWR ratings for each component.

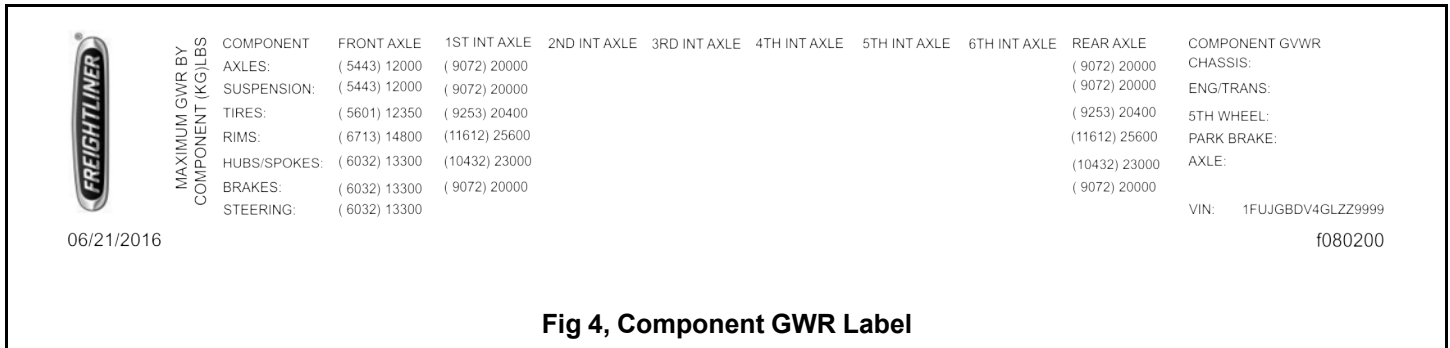
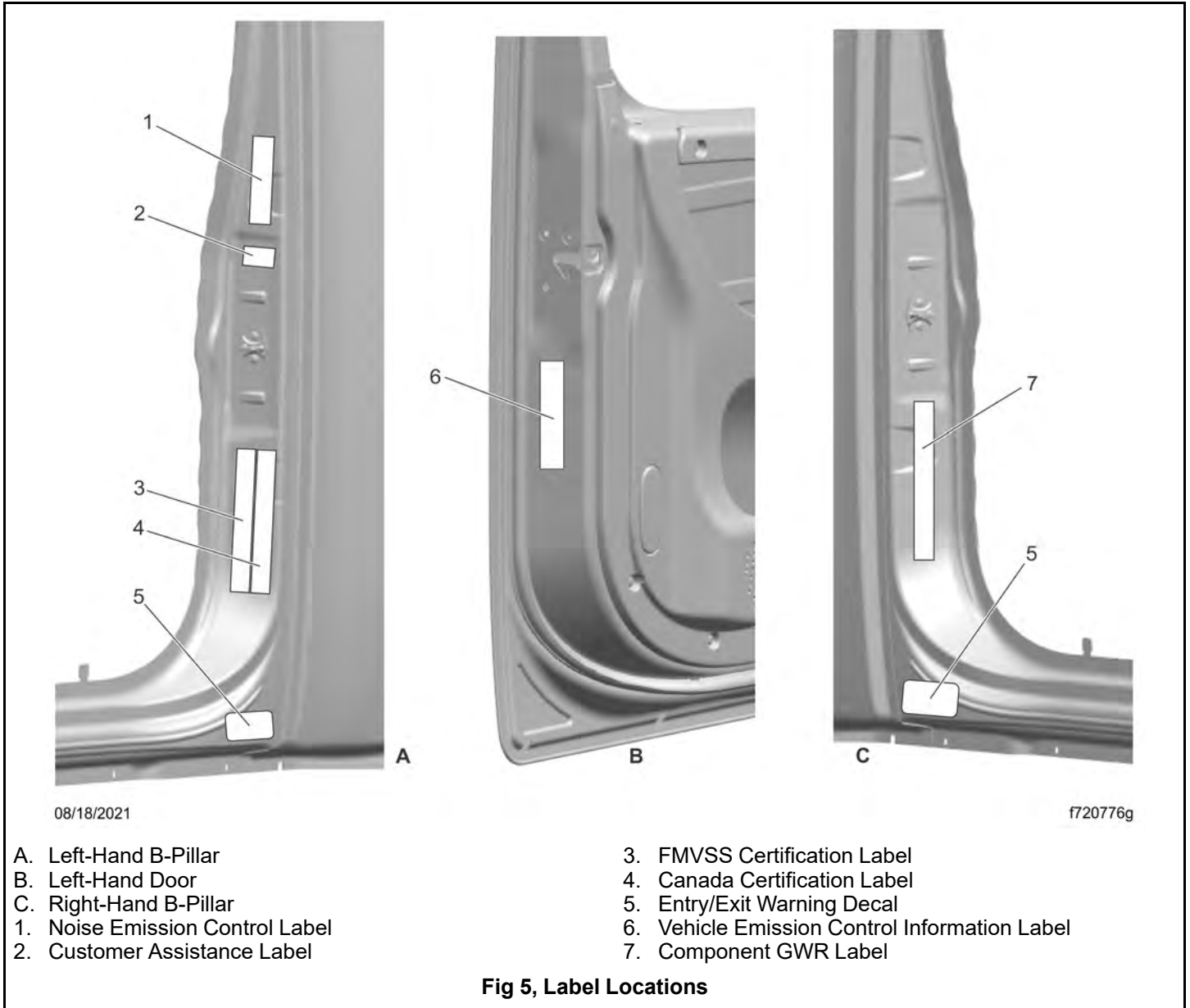

Fig 4, Component GWR Label

The component GWR label is located on the right-hand B-pillar as illustrated in see Fig.5, [Label Locations](#).



3.03 Federal Motor Vehicle Safety Standard Label

Tractors with or without fifth wheels manufactured for the U.S. are marked as certified by means of an FMVSS certification label as shown, see Fig.7, **FMVSS Vehicle Certification Label (complete vehicle)**, which also lists suitable tire and rim combinations.

The tire and rim combinations listed on these labels are those that can be installed on the vehicle for the given gross axle weight rating. Tires and rims installed on the vehicle at the time of manufacture may have a higher load capacity than that certified by the tire and rim label.

If the tires and rims currently on the vehicle have a lower load capacity than that shown on the tire and rim label, then the tires and rims determine the load limitations on each of the axles.

An FMVSS label is attached to the left-hand B-pillar as shown, see Fig.6, **Label Locations**. It is applied on the interior edge for vehicles domiciled in the United States or manufactured for U.S./Canada operation.

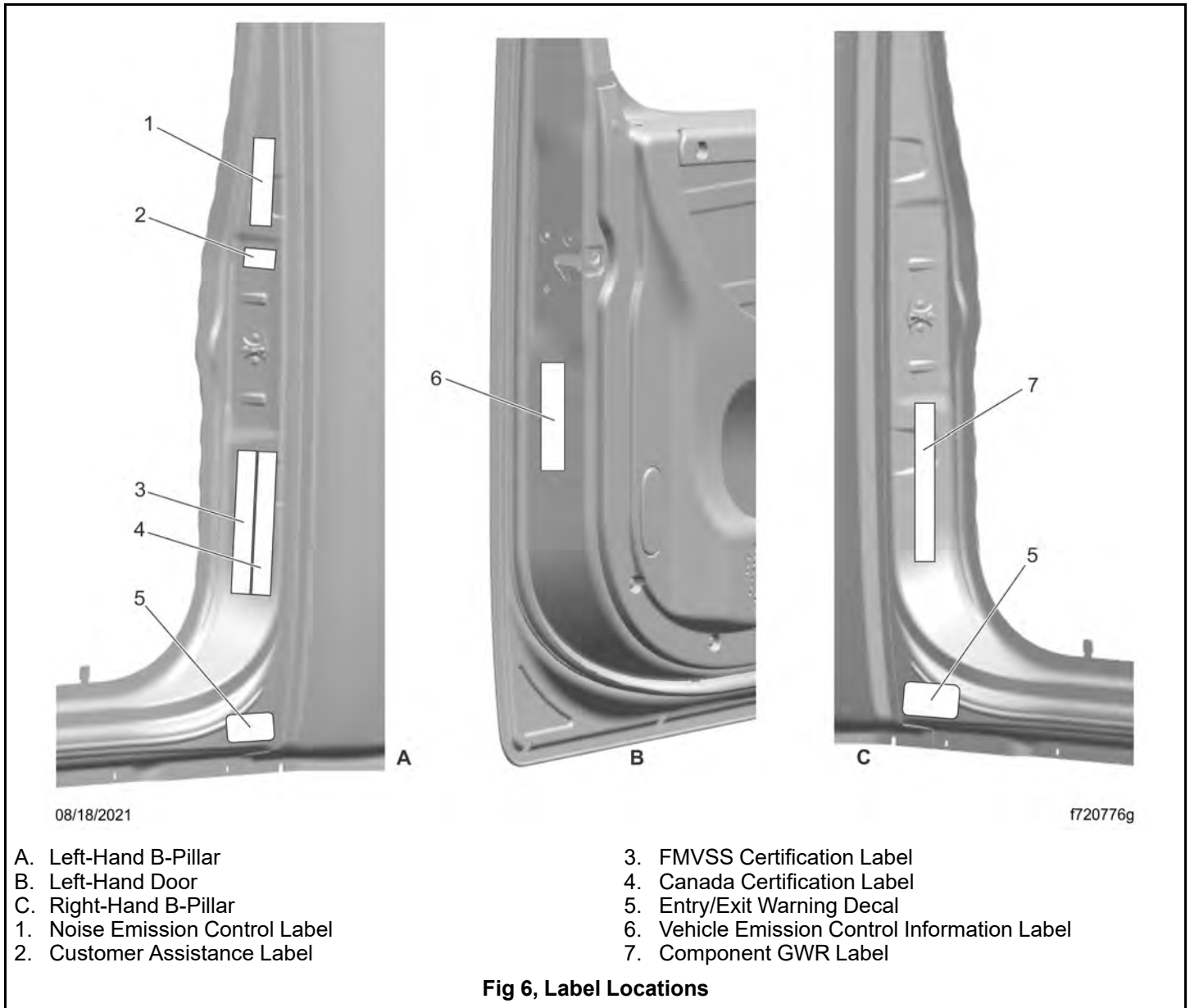

Tractors built without a fifth wheel for U.S. operations will have an incomplete FMVSS vehicle certification label. The incomplete vehicle documentation included with the vehicle will certify the vehicle conforms to all applicable regulations in effect on the date of completion. The final certification label must be attached by the final-stage manufacturer.

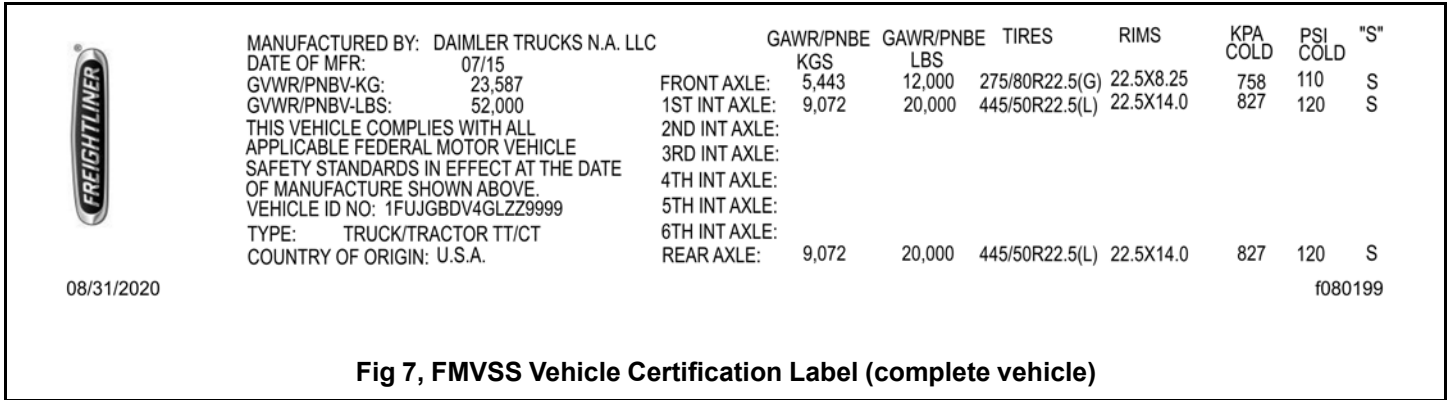

3.04 Canada Certification Label

Complete tractors with fifth wheels manufactured for Canada are marked with a Canada certification label as shown, see Fig.8, [Canadian Certification Label](#), attached to the left-hand B-pillar.

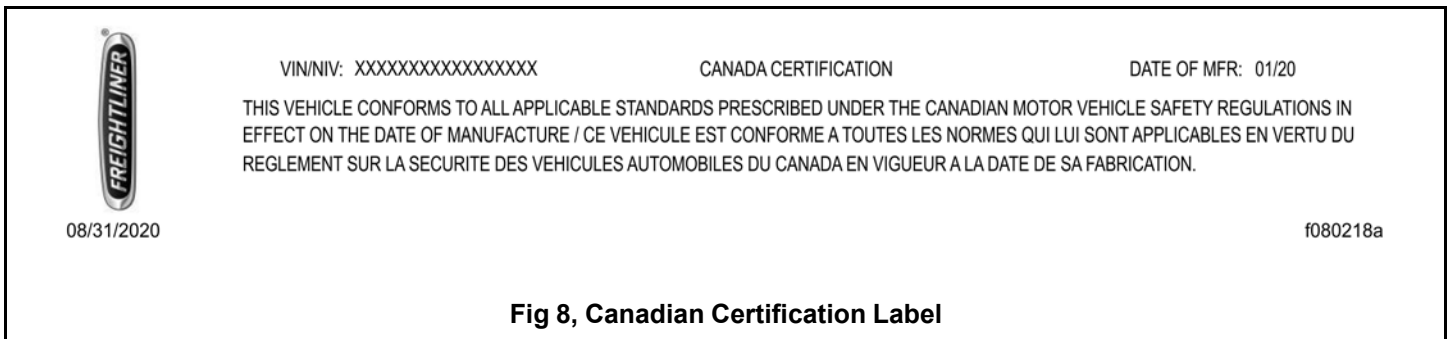

Complete tractors with fifth wheels manufactured for dual Canada/United States operations will have both a FMVSS certification label and Canada certification label. In this case the FMVSS certification label will be applied on the interior edge of the B-pillar and the Canada certification label will be applied on the exterior edge as shown, see Fig.9, [Label Locations](#).

Trucks built without a cargo body and tractors built without a fifth wheel that are intended for service in Canada will have an incomplete Canada vehicle certification label attached to the left-hand B-pillar. After completion of the vehicle, a complete Canada certification label must be attached by the final-stage manufacturer to certify that the vehicle conforms to all applicable vehicle safety regulations in effect on the date of completion.

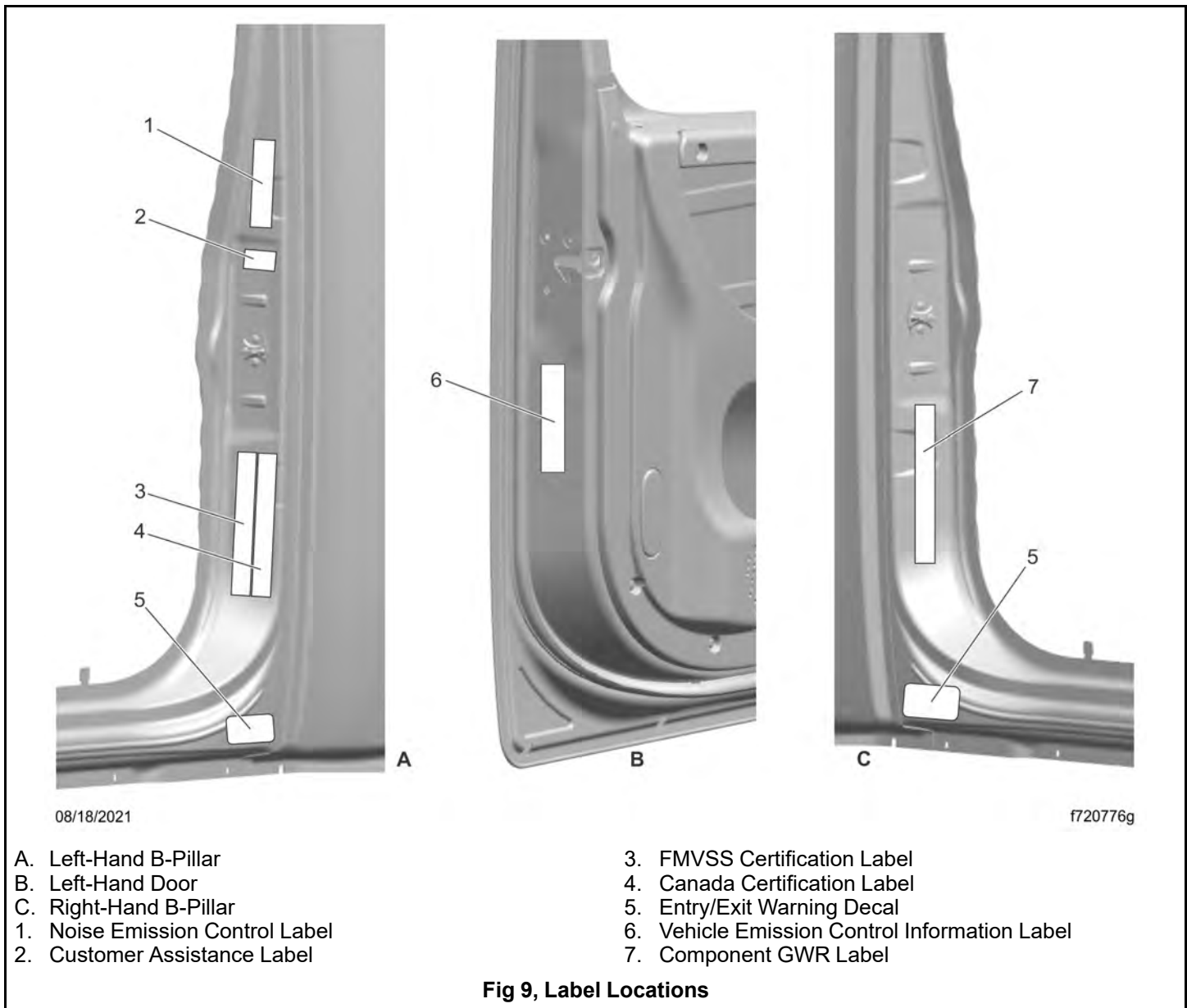

3.05 Emissions Labels

3.05.01 Vehicle Emission Control Information Label

Model year 2013 and later vehicles meet requirements as specified by GHG14, GHG17 and GHG21 regulations. These vehicles are equipped with components that increase fuel efficiency and reduce greenhouse gas (GHG) emissions. Components may include, but are not limited to, low-rolling resistance tires; aerodynamic devices such as hood, cab side extenders, and fuel tank fairings; vehicle speed limiters; and idle shutdown timers.

See Table.1, [EPA Regulations](#) and see Table.2, [Emission Regulations by Model Year](#) for additional information on what EPA and GHG regulations apply to different model years.

EPA Regulations	
Regulation	Emissions Components
EPA10 (Reduction of NOx emissions to 0.2 g/bhp-hr)	EPA07-type ATD, with additional selective catalyst reduction (SCR) technology that utilizes diesel exhaust fluid (DEF) to convert NOx to nitrogen and water vapor.
GHG21	GHG14/17 components plus additional components including, but not limited to, transmissions, axles, predictive technologies, idle reduction technologies for vocational vehicles, and tire pressure monitoring systems.

Table 1, EPA Regulations

Emission Regulations by Model Year		
Model Year	Engine Regulation	Vehicle Regulation
2021–and later	EPA10, GHG21	GHG21

Table 2, Emission Regulations by Model Year

It is a violation of U.S. federal law to alter components that would bring the vehicle out of compliance with certification requirements [Ref: 42 U.S.C. S7522(a) (3)]. It is the owner’s responsibility to maintain the vehicle so that it conforms to EPA regulations.

A vehicle emission control information label is located on the left-hand door. See Fig. 11, [Label Locations](#). Among other GHG relevant information the label, as shown, see Fig. 10, [Vehicle Emission Control Information Label](#). indicates the emission model year of the vehicle.

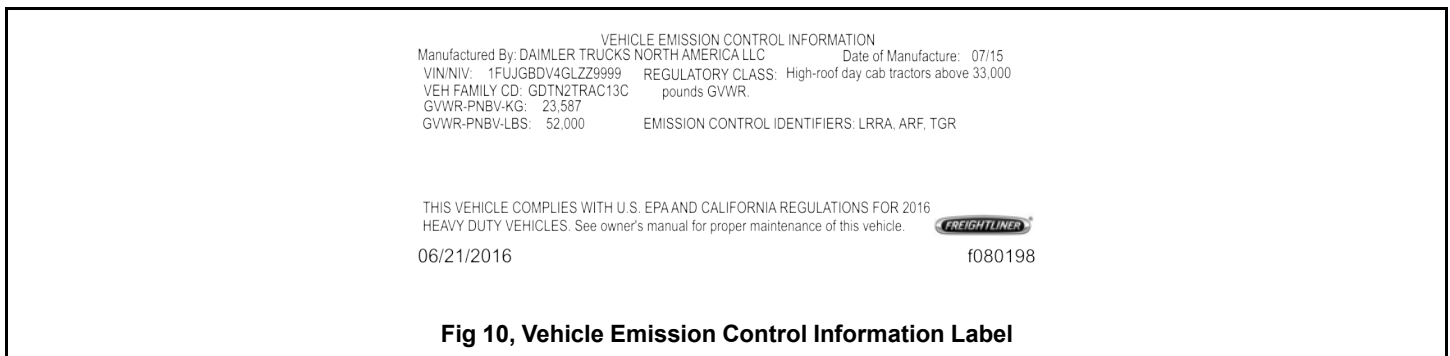
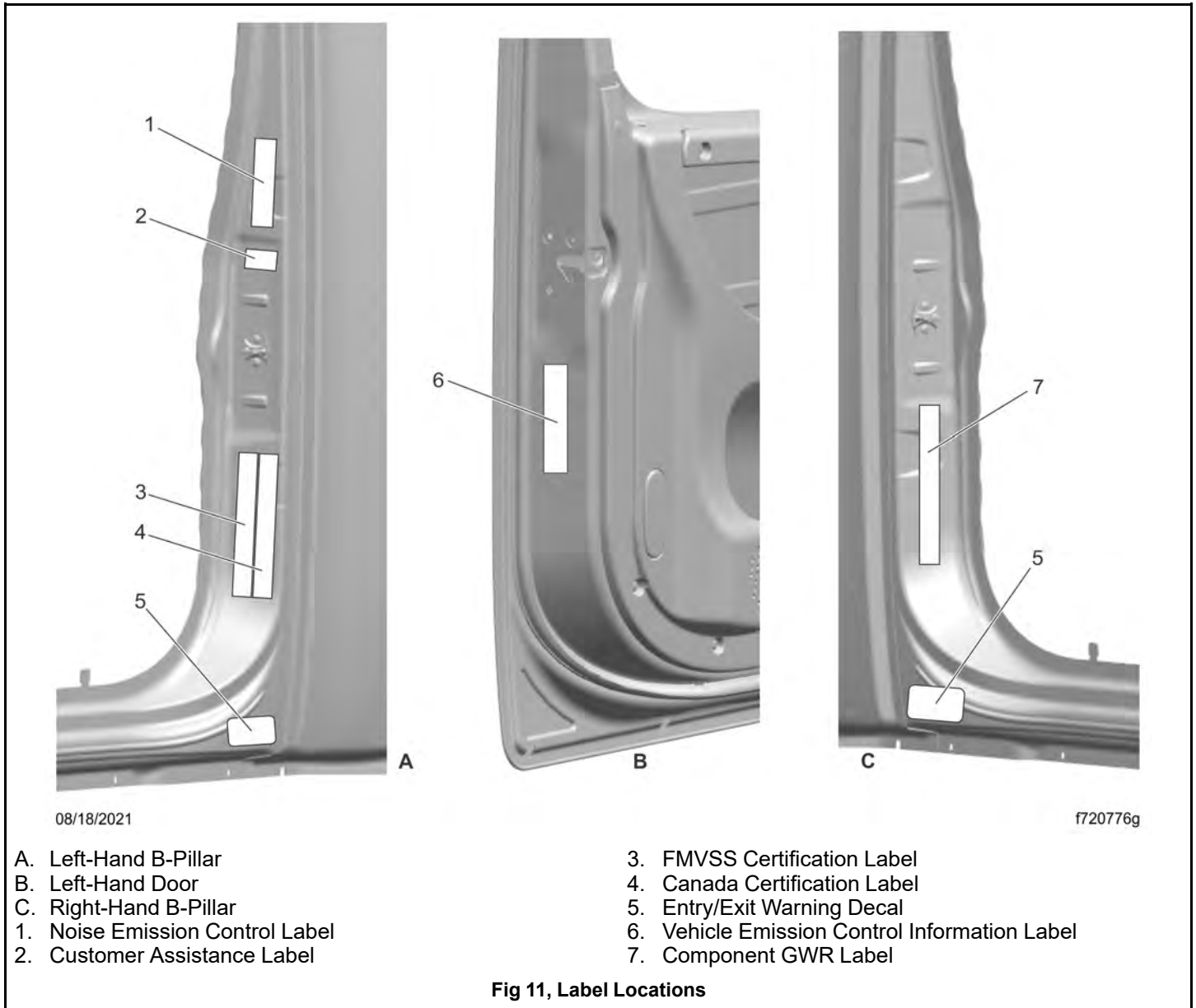

Fig 10, Vehicle Emission Control Information Label



3.05.02 Noise Emission Control Labels

For vehicles manufactured for operation in the United States, an EPA noise emission control label as shown, see Fig. 13, [EPA Vehicle Noise Emission Control Label \(complete vehicle\)](#), is applied to attest that the vehicle conforms to United States EPA regulations for noise.

The noise emission control label is applied to the left-hand B-pillar as shown, see Fig. 12, [Label Locations](#).

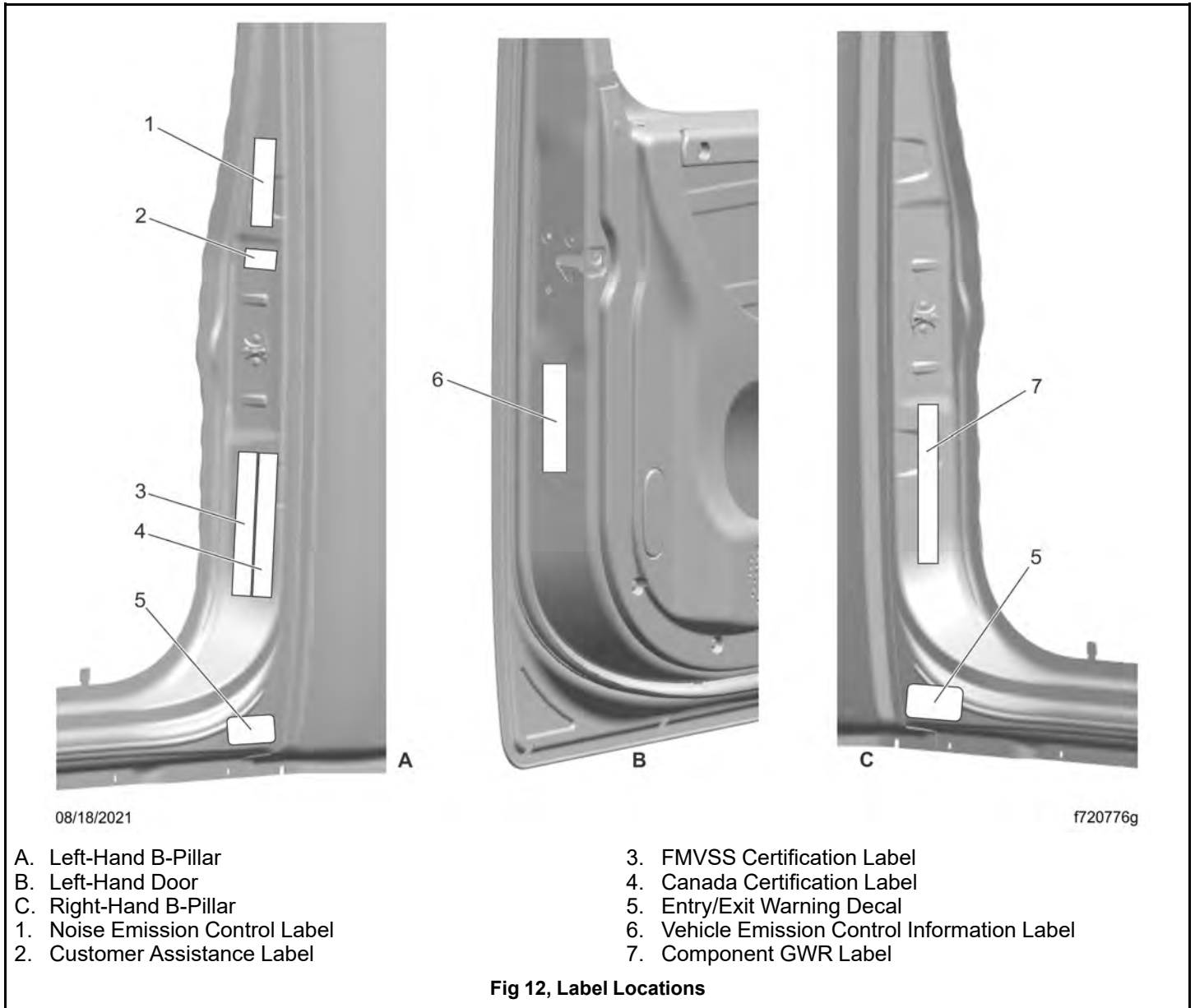

It is the owner's responsibility to maintain the vehicle so it conforms to all applicable regulations.

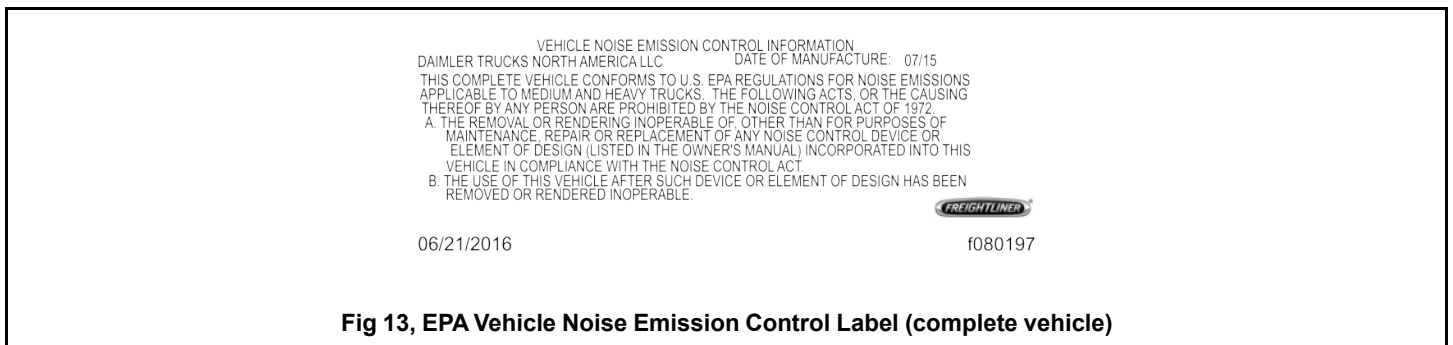

IMPORTANT: Certain Freightliner incomplete vehicles may be produced for the United States market with incomplete noise control hardware. Such vehicles will have an incomplete vehicle noise emission control information label as shown, see Fig. 14, [EPA Vehicle Noise Emission Control Label \(incomplete vehicle\)](#). For such vehicles, it is the final-stage manufacturer's responsibility to complete the vehicle in conformity to the applicable regulations and label it for compliance.

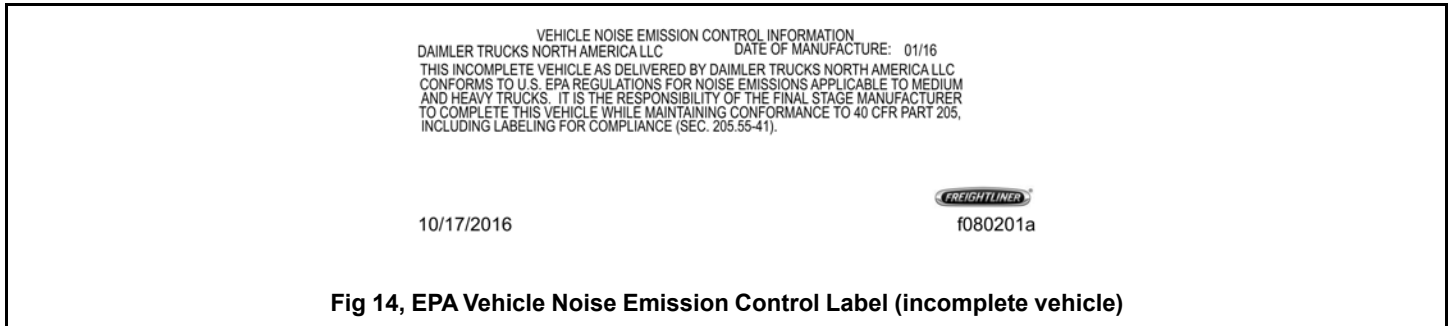

3.06 Customer Assistance Label

The customer assistance center telephone number is printed on the customer assistance label as shown, see Fig. 15, [Customer Assistance Label](#). The label also includes a QR code encoded with the VIN, readable by dealer apps, to bring up information about the vehicle.



The customer assistance label is located on the left-hand B-pillar, as shown, see Fig. 16, [Label Locations](#).

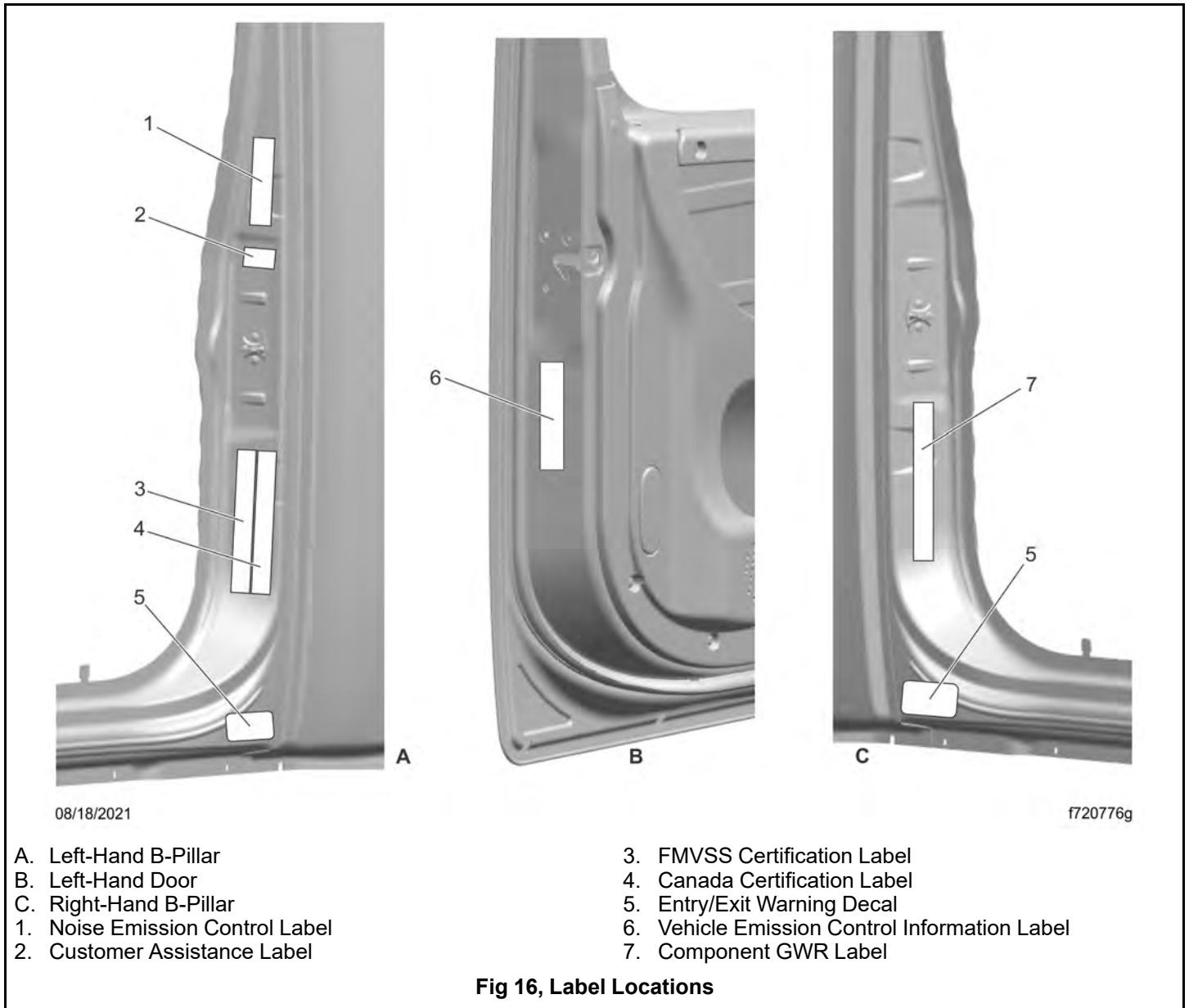

4.01 Using the Key Fob	24
4.01.01 Key Fob Use.....	24
4.01.02 Key Fob Programming	25
4.01.03 Specifications	25
4.02 Opening the Doors	25
4.03 Entering and Exiting the Vehicle	26
4.03.01 General Information	26
4.03.02 Entering the Driver Side.....	27
4.03.03 Exiting the Driver Side	28
4.03.04 Entering the Passenger Side	29
4.03.05 Exiting the Passenger Side	29
4.04 Opening the Hood	30
4.05 Closing the Hood.....	33

4. Vehicle Access

4.01 Using the Key Fob

4.01.01 Key Fob Use

**DANGER:**

Do not ingest the key fob battery. The button cell battery in this key fob is a chemical burn hazard.

Always keep the key fob and button cell batteries away from children.

Always safely dispose of used batteries.

If the button cell battery in this key fob is swallowed, it can cause severe internal burns within two hours and can lead to death. If you think a battery might have been swallowed or otherwise placed inside any part of the body, seek immediate medical attention.

If the battery compartment does not close securely, stop using the key fob.

Keyless entry is standard on these vehicles. The key fob can be used to remotely lock and unlock the doors, start and end the pre-trip light check, and open the side windows. See Fig.17, [Key Fob](#).

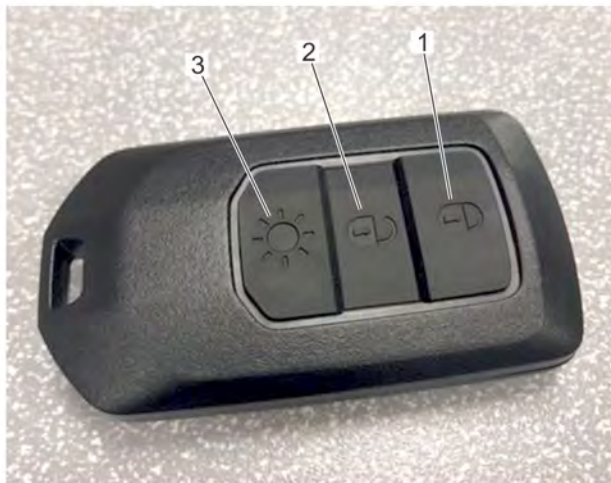

10/23/2019

f546880a

1. Lock Button
2. Unlock Button

3. Lamp Check Button

Fig 17, Key Fob

- To lock both doors, press the lock button.
- To unlock both doors, press the unlock button.
- To open the side windows, press the unlock button for three seconds.
- To start or end the pre-trip light check, press the lamp check button.

4.01.02 Key Fob Programming

A maximum of four fobs can be programmed to work on one vehicle. Whenever a new fob is needed, all existing fobs must be reprogrammed at the same time. Any existing fobs that were previously programmed will no longer work on the vehicle unless they are all reprogrammed at the same time.

To have the key fobs programmed, take the vehicle to an authorized Freightliner dealer or service facility.

4.01.03 Specifications

This system consists of a key fob that uses a radio frequency link for communication between the fob and the vehicle.

4.02 Opening the Doors

The physical key can be used to lock and unlock the doors and activate the electrical system.

IMPORTANT: Record the key number so, if needed, a duplicate key can be made.

NOTE: The cab door locks can be operated when the doors are open.

To unlock the driver's door from outside the cab, insert the key in the lock and turn it one-quarter turn clockwise. To remove the key, turn it counterclockwise to the original position. Pull the door pull handle as shown, see Fig. 18, [Exterior Door Handle](#) to open the door.

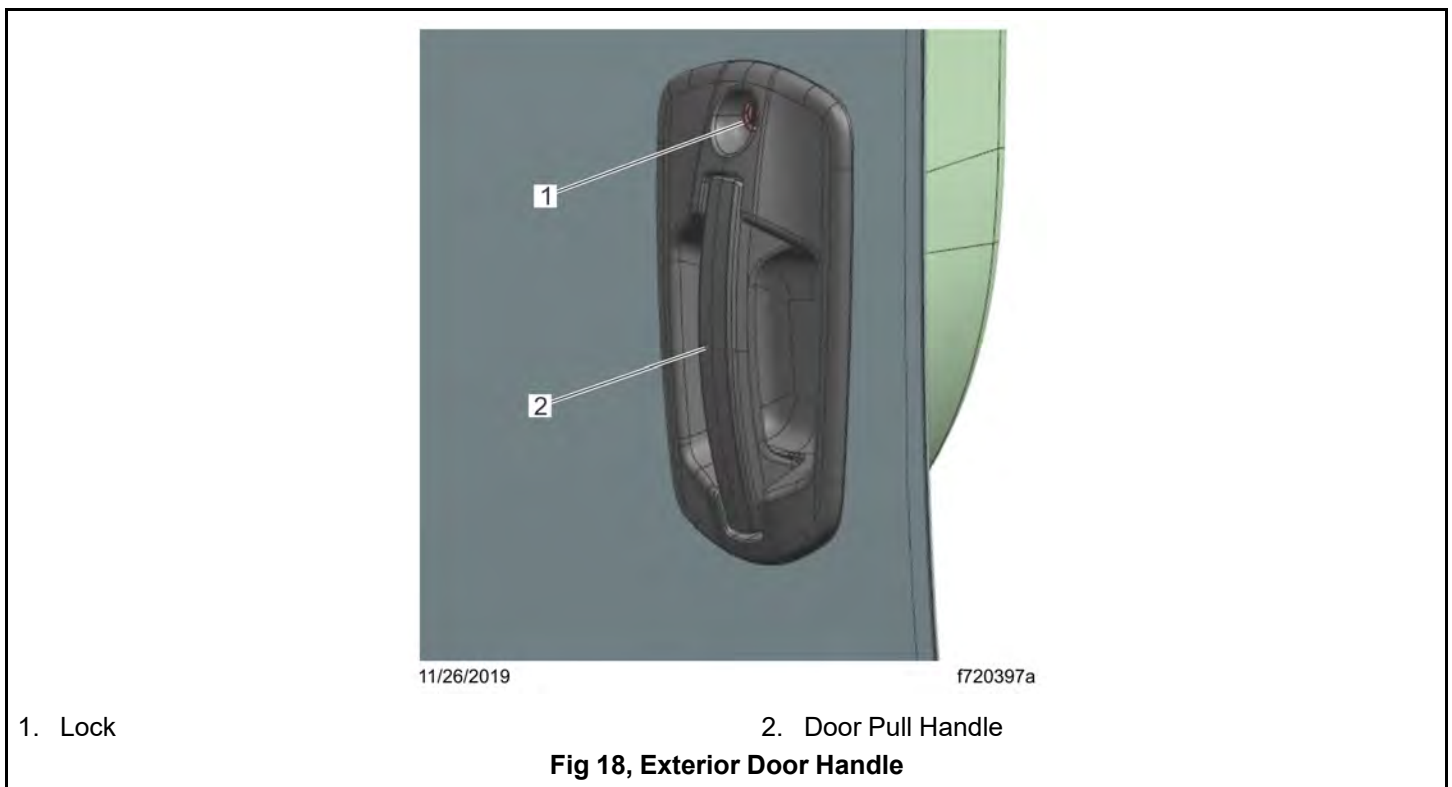

To unlock the passenger's door from outside the cab, insert the key in the lock and turn it one-quarter turn counterclockwise. Turn the key clockwise to the original position to remove it.

To lock a door from outside the cab, close the door if it is open, insert the key in the lock, and turn it in the direction opposite to the unlocking direction (counterclockwise for the driver's door, clockwise for the passenger's door).

To lock either door from inside the cab, push the lock button downwards. See Fig. 19, [Door Interior](#).



1. Lock Button
2. Integral Grab Handle
3. Opening Lever

4. Control Panel
5. Door Light

Fig 19, Door Interior

To open the door from the inside, lift up on the door lever. This will unlatch the door whether or not it is locked.

To unlock the door without unlatching it, pull the lock button upwards.

4.03 Entering and Exiting the Vehicle

4.03.01 General Information



CAUTION:

Slipping or falling from the vehicle can result in personal injury or property damage.

Wet or dirty shoes greatly increase the chance of slipping or falling. If your shoes are wet or dirty, be especially careful when entering or exiting the vehicle.

Always maintain three-point contact with the vehicle when entering or exiting the cab. Three-point contact means both feet and one hand, or both hands and one foot.

Do not jump from the vehicle.

For ease of entry and exit, grab handles are attached to the B-pillars, an integral handle is molded into the door interior, and the steering wheel may be used to provide a secure handhold. At least two access steps provide secure footholds.

Follow the instructions on the warning labels, as shown in Fig.20, [Cab Access Warning Label](#), when entering and exiting the cab.



Fig 20, Cab Access Warning Label

4.03.02 Entering the Driver Side

1. Open the driver-side door and place anything that you are carrying in the cab.
2. Facing the cab, grasp the B-pillar grab handle with both hands. See Fig.21, [Driver-Side Cab Access](#).



- | | |
|-------------------------|-------------------------|
| 1. Bottom Step | 4. Steering Wheel |
| 2. Top Step | 5. Exterior Grab Handle |
| 3. B-Pillar Grab Handle | |

Fig 21, Driver-Side Cab Access

3. Step up on the bottom step with your right foot.
4. Step up on the top step with your left foot, grasping the exterior grab handle higher with your right hand as you move up, and grasp the door interior integral grab handle with your left hand.

5. Grasp the steering wheel with your right hand, then step into the cab with your right foot first.

4.03.03 Exiting the Driver Side

IMPORTANT: Do not attempt to exit the cab while carrying any items in your hands. Place them in an accessible location on the seat or cab floor and make sure they will not get in your way as you exit, then retrieve them after you have exited the cab.



CAUTION:

Always face in when exiting the vehicle. Do not exit the vehicle as you would going down a flight of stairs as this makes it more likely you'll slip or lose your balance. In addition, if you slip when exiting the vehicle facing outwards there is a greater likelihood of personal injury.

1. Grasp the steering wheel with your right hand, and the integrable door grab handle with your left hand, then place your left foot on the top step. See Fig.22, [Driver-Side Cab Access](#).

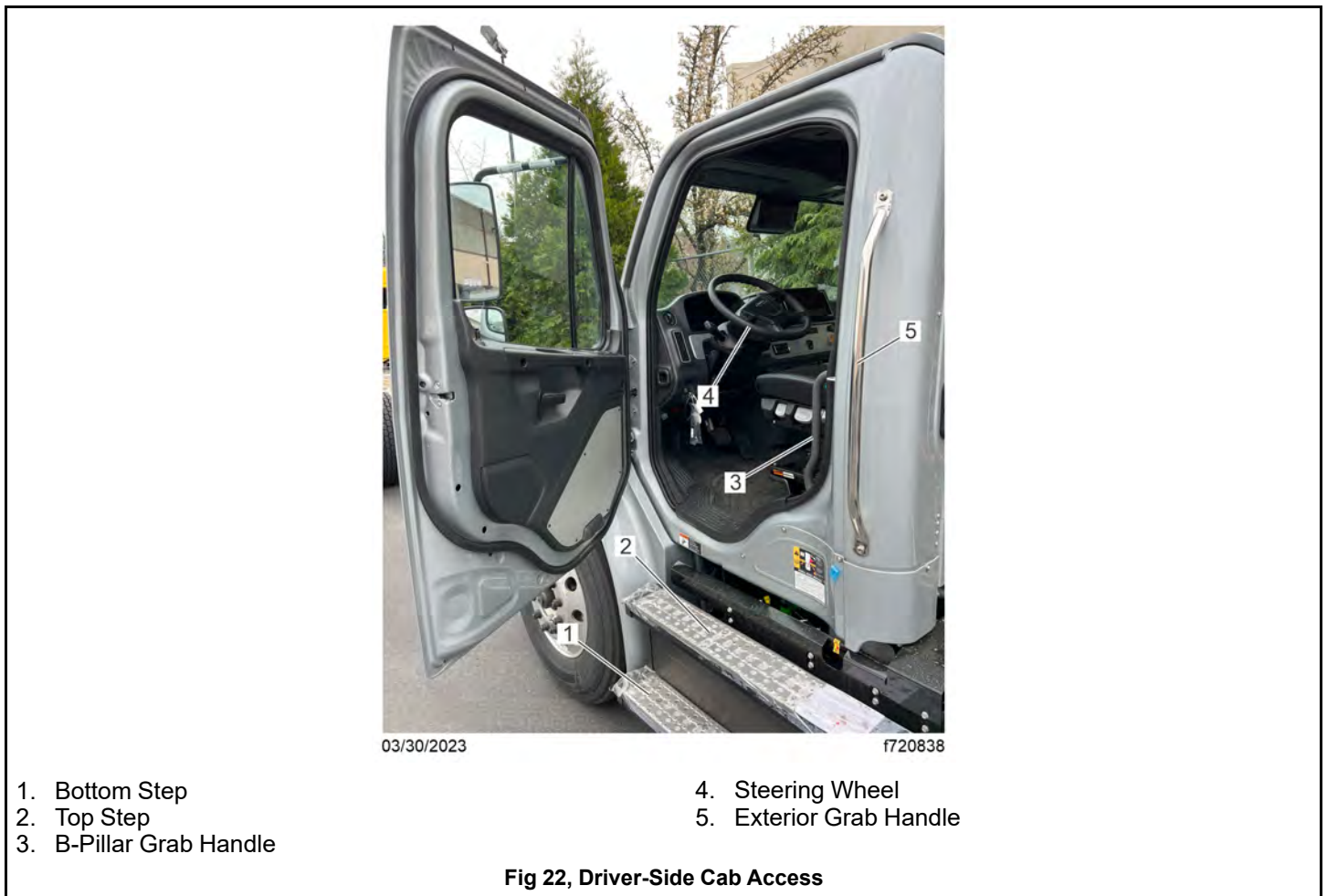

1. Bottom Step
2. Top Step
3. B-Pillar Grab Handle

4. Steering Wheel
5. Exterior Grab Handle

Fig 22, Driver-Side Cab Access

2. Face into the cab, and grasp the B-pillar grab handle with your right hand.
3. Step down on the bottom step with your right foot, grasping the exterior grab handle lower as you move down. If necessary grasp the exterior grab handle with both hands.

4. Step to the ground with your left foot first.

4.03.04 Entering the Passenger Side

1. Open the passenger-side door and place anything that you are carrying in the cab.
2. Facing the cab, grasp the B-pillar with your left hand, and the A-pillar grab handle with your right hand. See Fig. 23, [Passenger-Side Cab Access](#).



04/03/2023

f720839

1. Bottom Step
2. Top Step

3. B-Pillar Grab Handle
4. A-Pillar Grab Handle

Fig 23, Passenger-Side Cab Access

3. Step up on the bottom step with your left foot.
4. Step up on the top step with your right foot, grasping the grab handles higher as you move up.
5. Step into the cab with your left foot first, while holding on to the grab handle with your right hand.

4.03.05 Exiting the Passenger Side

IMPORTANT: Do not attempt to exit the cab while carrying any items in your hands. Place them in an accessible location on the seat or cab floor and make sure they will not get in your way as you exit, then retrieve them after you have exited the cab.

**CAUTION:**

Always face in when exiting the vehicle. Do not exit the vehicle as you would going down a flight of stairs as this makes it more likely you'll slip or lose your balance. In addition, if you slip when exiting the vehicle facing outwards there is a greater likelihood of personal injury.

1. Grasp the A-pillar grab handle with both hands, and place your right foot on the top step. See Fig. 24, [Passenger-Side Cab Access](#).



04/03/2023

f720839

1. Bottom Step
2. Top Step

3. B-Pillar Grab Handle
4. A-Pillar Grab Handle

Fig 24, Passenger-Side Cab Access

2. Face into the cab, and grasp the B-pillar grab handle with your left hand.
3. Step down on the bottom step with your right foot, grasping the grab handles lower as you move down.
4. Step to the ground with your left foot first.

4.04 Opening the Hood

1. Apply the parking brakes.

2. Release both hood hold-down latches by pulling the ends outward. See Fig.25,[Hood Hold-Down Latch Engaged](#) and see Fig.26,[Hood Hold-Down Latch Opened](#).



04/04/2023

f881066

A. Pull upwards on the latch to open.

Fig 25, Hood Hold-Down Latch Engaged



04/04/2023

f881067

Fig 26, Hood Hold-Down Latch Opened

3. Slowly tilt the hood with both hands on the hood handle.
4. As the hood starts to open, walk backwards as you pull. Tilt-assist struts help to both raise the hood and lower it, and restraint straps prevent the hood from over travel. See Fig.27, [Hood Assist](#). The hood will stop in the full-open position.



1. Restraint Strap

2. Hood Strut

Fig 27, Hood Assist

4.05 Closing the Hood

1. Push on the hood above the grille, tilting it toward the closed position.
2. As the hood goes over center, allow it to settle on the rear supports.

IMPORTANT: Make sure that both hood hold-down latches are fully engaged before operating the vehicle.

3. Make sure the hood is flush with the cowl, then secure the hood by engaging both hood hold-down latches.

5.01 ICC5 Overview.....	37
5.01.01 General Information	37
5.01.02 ICC5 Self-Check Sequence	37
5.02 Driver Display	38
5.02.01 General Information	38
5.02.02 Basic Driver Display Functions.....	40
5.03 Touch Screen Overview	40
5.03.01 Infotainment Screen	40
5.03.02 General Information	41
5.03.03 System Settings.....	41
5.03.04 Touch Screen Operation.....	41
5.04 Digital Instruments	42
5.04.01 Gauges	42
5.04.02 Battery and eDrive Coolant Levels	43
5.04.03 eAxle Oil Temperature Pop ups.....	43
5.04.04 Application Air Pressure Gauge	43
5.04.05 Suspension Air Pressure Gauge	43
5.04.06 Base ICC5 A-Panel Gauges	43
5.04.07 Battery Voltage	43
5.04.08 Speedometer.....	43
5.04.09 Primary and Secondary Air Gauges.....	44
5.04.10 ICC5 Chassis Status Information.....	44
5.04.11 Tire Pressure Monitoring System (TPMS)	44
5.04.12 Axles	45
5.04.13 Diagnostics	45
5.04.14 Active Driver Alerts	45
5.04.15 Instrument and Infotainment Screen Controls.....	46
5.04.16 Digital Switches	46
5.04.17 Lighting	46
5.04.18 Settings.....	46
5.04.19 Climate Control Information	48

- 5.05 Infotainment Controls 48
 - 5.05.01 Phone Connection Overview..... 48
 - 5.05.02 Connecting and Disconnecting a Phone Using Bluetooth®..... 48
 - 5.05.03 Using a Mobile Phone 51
 - 5.05.04 Phone Contacts and Call List 53
 - 5.05.05 Radio 55
 - 5.05.06 Sound System Settings 57
 - 5.05.07 Accessing Sound Settings 57
 - 5.05.08 Favorites 58
 - 5.05.09 Media..... 58
 - 5.05.10 Smartphone 59
- 5.06 Clock Settings..... 59
- 5.07 Telltale Warnings and Messages 60

5. Instruments

5.01 ICC5 Overview

5.01.01 General Information

The ICC5 instruments include a driver display screen, a touch screen for infotainment and digital gauges screens, and multiple visual and audible warning systems. See Fig.28, [ICC5 Instruments](#).



The driver display provides the driver with current information about the vehicle and vehicle systems.

The touch screen provides access to digital instruments and gauges, charging, phone, and radio controls.

The steering wheel has switch pods that can also be used to view the digital instruments and features screens. The left-hand pod has a quick-access button for screens that are frequently viewed in the driver display. The buttons in the right-hand pod work with the infotainment features and menus. See [6.01 Steering Wheel Pods](#), Driver Controls, for details of the steering wheel switch pods.

5.01.02 ICC5 Self-Check Sequence

When the keyswitch is turned ON, the ICU runs a self-check. Observing the self-check sequence is a good way to ensure the ICC5 is functioning properly. See [12.02.01 Starting the Vehicle](#) under **Vehicle Charging, Operation, and Shutdown** for details.

IMPORTANT: If any red warnings or amber cautions do not go out after the self-check completes, take the action outlined in the warning or caution. Dismissed warnings and cautions can be found under 'Active Driver Alerts' on the infotainment screen under the 'Chassis' menu. If necessary, take the vehicle to an authorized Freightliner service facility.

5.02 Driver Display

5.02.01 General Information

The ICC5 driver display is used to communicate current information about the vehicle. The information shown depends on the status of the vehicle (such as charging or driving), the features the vehicle is equipped with, and the status of available features.

A driver display of an truck that is parked with the power train off looks similar as shown in Fig.

29, [Truck Driver Display - Parked, Powertrain Off, with Trip Meter Selected](#). Telltales may display at the top, bottom, right, and left side of the screen.

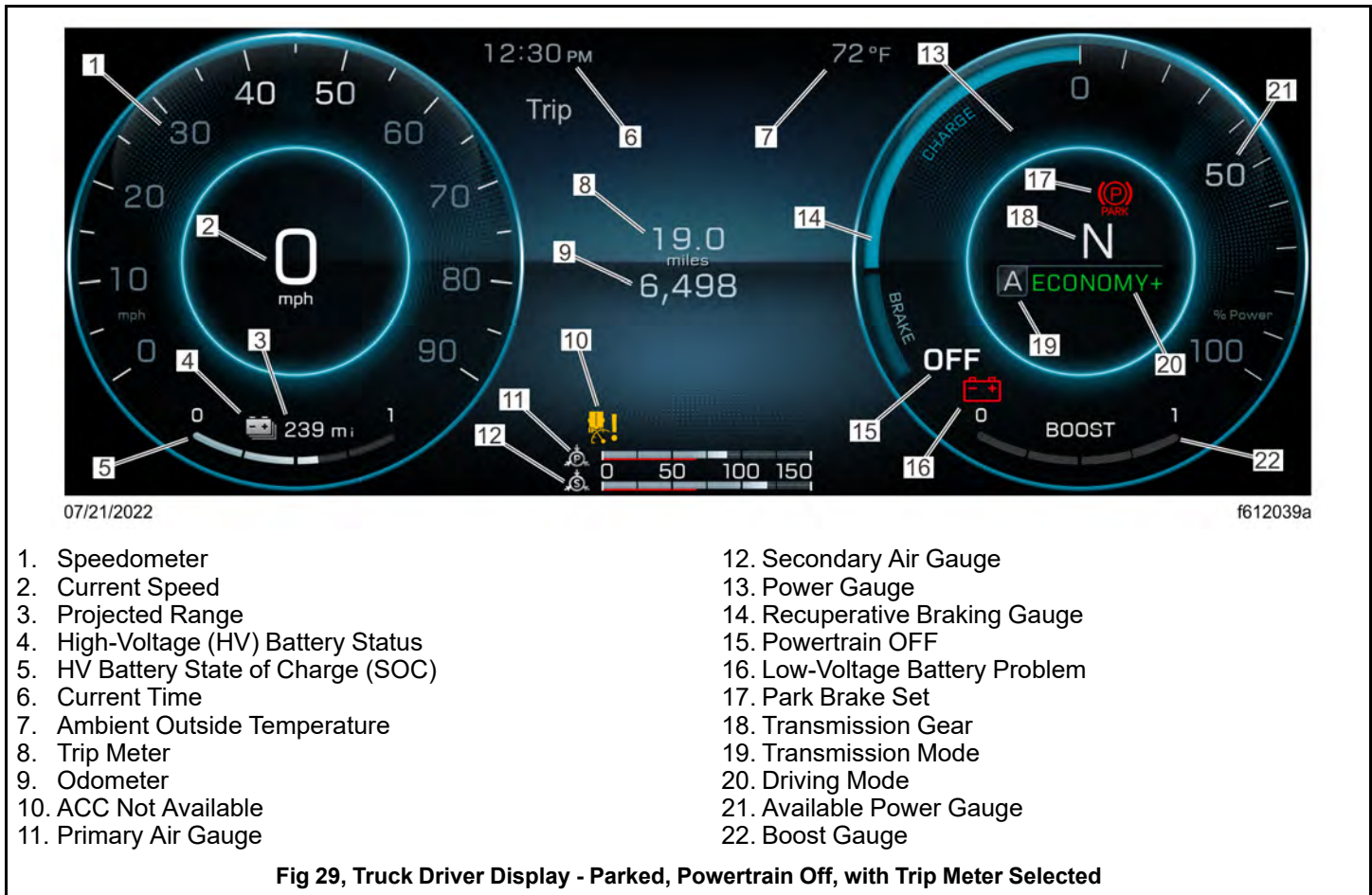

A stationary vehicle with the powertrain on would show the powertrain status of READY, the speedometer and power gauge needles at 0, and applicable telltales.

When driving, the center of driver display shows driving assistance information as shown, see Fig.

30, [Truck Driver Display - Driving](#).



07/21/2022

f612040

- | | |
|--|--|
| <ul style="list-style-type: none"> 1. Current Speed 2. High-Voltage Battery Status 3. Projected Range on Current State of Charge 4. High-Voltage Batteries State of Charge 5. Speed of Vehicle Ahead 6. Distance to Vehicle Ahead 7. Adaptive Cruise Control (ACC) Active Telltale 8. Lane Keep Assist (LKA) Active Telltale | <ul style="list-style-type: none"> 9. Maximum Recuperative Braking Level Requested 10. Current Power Usage 11. Suggested Transmission Gear 12. Current Transmission Gear 13. Current Driving Mode 14. Powertrain Ready Telltale 15. Power Limit in Current Driving Mode |
|--|--|

Fig 30, Truck Driver Display - Driving

The quick access menu, accessed from the steering wheel left-hand pod, shows short cuts to the most used features in the driver display. See Fig.31, [Truck Driver Display - Quick Access Menu](#).



08/11/2022

f612186

- | | |
|--|---|
| <ul style="list-style-type: none"> 1. Coolant Temp 2. Phone 3. Odometer 4. Trip Computer | <ul style="list-style-type: none"> 5. Range 6. Audio 7. Driving Assistance |
|--|---|

Fig 31, Truck Driver Display - Quick Access Menu

5.02.02 Basic Driver Display Functions

Alert Messages

Alert messages appear at the center of the driver display when certain conditions occur. They include warnings, cautions, and notices that require the driver's attention. Not all alert messages are critical to the operation of the vehicle. More important messages take priority over less important messages. The header text and color indicates the priority of the on-screen message, listed from the highest to the lowest:

- Warning (red)
- Caution (amber)
- Status/Informational (blue, green, white, and grey)

Warnings alert the driver to situations or conditions that may pose a threat to control of the vehicle. Follow all instructions given in the message.

Cautions alert the driver to situations or conditions that may result in damage to vehicle components, or derating of motor power.

Status notices alert the driver to situations or conditions that may improve fuel efficiency or vehicle handling.

Software Updates

A software update consists of three steps:

1. Downloading the software.
2. Installing the software.
3. Activating the software by restarting the system.

A pop up message and a blue folder appear in one of the dynamic telltale locations on the driver display when an update is available. In addition the software update option in the diagnostics menu is active.

The vehicle must be in neutral gear, the parking brake set, and the motor off before a software update can start. Once started, a software update cannot be cancelled.

During the software update process, progress messages are provided.

If a software update is interrupted, the system asks if you want to restart the process or informs you that the vehicle cannot be driven until the update is complete. If a software update fails, the system attempts to revert to the previous version. A notification appears when a software update has been successfully installed.

Failure to install software updates may make data less secure and/or mean vehicle systems are not operating at their best.

NOTE: An estimation of installation time is given before the software update starts. Installation can take several minutes. During installation individual functions and controls are not available or only available to a limited degree.

Temperature

In the ICC5 the ambient air temperature displays at the top and slightly to the right on the driver display screen. The temperature can be set to display in °F or °C in Settings.

When ambient air temperature drops below 34°F (1°C), a snowflake icon will appear below the display temperature to warn of possible ice. The snowflake icon will display until the ambient air temperature rises to 37°F (3°C).

5.03 Touch Screen Overview

5.03.01 Infotainment Screen

The instrument and infotainment touch screen displays charging information, instrument gauges, and cab and chassis information. It also provides access to lighting and radio controls and manages the integration of phone, smart phone and media sources. Each corner of the instrument and infotainment display has a quick access icon for commonly used features. For

an overview of menu category icons as well as quick access icons, see Fig. 32, [Infotainment Menu Options, Icons, Status Line – ICC5](#).



NOTE: Screens vary depending on vehicle options. Some screens are accessible only when the vehicle is parked.

5.03.02 General Information

Information and controls available on the ICC5 instrument and infotainment display:

- Shortcut icons, statusline, and climate bar
- Gauges
- Cab Controls and Information
- Chassis Information
- Lighting Controls
- Phone Controls
- Radio Controls
- Media
- Smartphone Controls [*see phone controls*]

5.03.03 System Settings

Select the gear icon to open the Settings menu. Settings is also available within the Cab menu.

5.03.04 Touch Screen Operation

IMPORTANT: Keyboard entries are locked when the parking brake is disengaged. Other touch screen options still function.

The touch screen responds to different forms of touching, including tapping, touching and holding, finger swiping, or touching, holding and moving.

Tapping

Tap the touch screen to:

- Select a menu item or entry by tapping on the symbol or entry.
- Enter characters with the keyboard by tapping on the character button.

Touching and Holding

Touch and hold to:

- Call up a global menu in the applications by touching the touchscreen and holding until the OPTIONS menu appears.

Finger Swiping

Use a finger swipe to:

- Navigate in menus by swiping up, down, left or right.
- Scroll through screens.

Touching, Holding and Moving

Touch, hold, and move the finger to:

- Change the value on a slider control by moving the finger to the left or right.

5.04 Digital Instruments

5.04.01 Gauges

The digital gauges as shown in Fig.33, [Example Gauge Screen - ICC5](#) can be accessed under the 'Gauges' menu on the touch screen display. They are informational only.

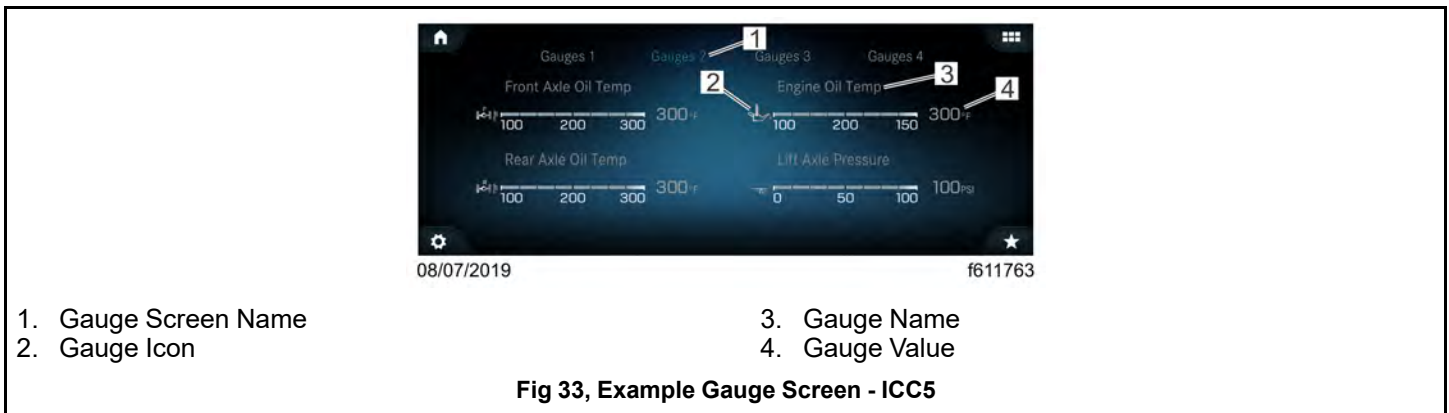

The default order of the gauge display can be changed. Pressing on an existing gauge causes a pop up window to appear with the option to either Remove or Replace the gauge. Choosing Replace brings up a radio button list of all available gauges from which to choose; replacing a gauge moves the first gauge into a different screen placement. Removing a gauge removes the gauge from the gauge screens. A removed gauge can be added back by pressing the Add or plus sign button. Doing so causes a radio button list to appear listing the gauges available to be added.

Gauge units of measurements are controlled under Settings which can be accessed under the Cab menu or by pressing the star menu icon in the lower left corner.

Move between gauge screens by pressing the gauge screen name at the top of the screen.

In the ICC5, if a value measured by a digital gauge exceeds the normal range, the gauge icon, display bar graph color, and gauge value change color to amber to indicate caution or red to indicate danger. See Fig. 34, [Gauge Caution and Warning Indicator Display - ICC5](#).

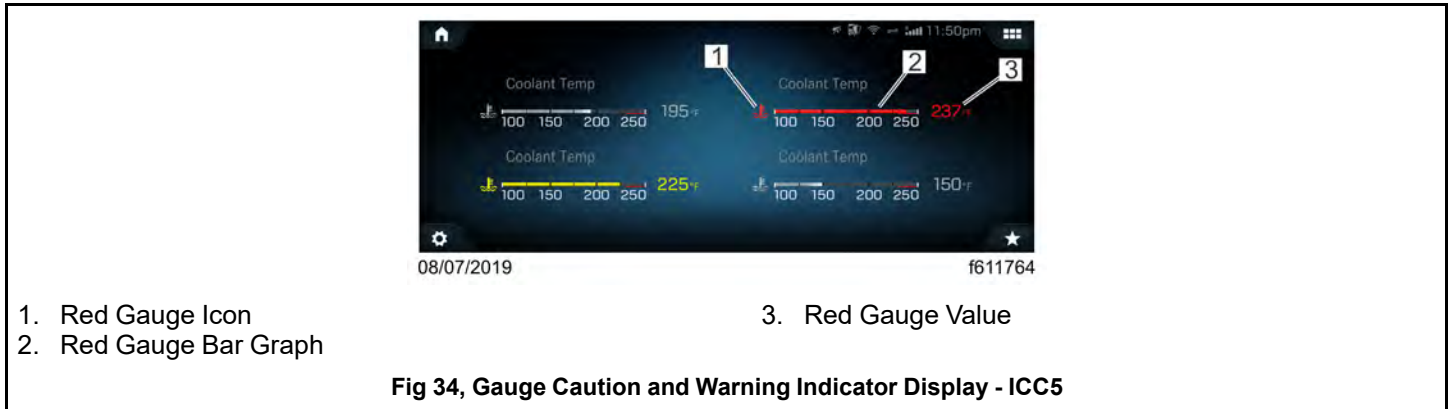

5.04.02 Battery and eDrive Coolant Levels

There are two coolant systems on the truck: the battery coolant and the eDrive coolant. The coolant level sensors report the coolant levels as either full or low.

5.04.03 eAxle Oil Temperature Pop ups

The driver display shows a yellow caution window if the gear box oil temperature is too high.

A red warning window displays on the driver screen if the rotational direction of the oil pump is unexpected.

Red warning windows also display if the operation of the oil pump is limited or not operating.

5.04.04 Application Air Pressure Gauge

An application air pressure gauge registers the air pressure being used to apply the brakes. The gauge does not register air pressure until the foot brake pedal is depressed.

5.04.05 Suspension Air Pressure Gauge

The suspension air pressure gauge registers the air pressure applied to the vehicle air suspension.

5.04.06 Base ICC5 A-Panel Gauges

Outside of the gauges screen, the ICC5 displays a number of other digital gauges and instruments.

5.04.07 Battery Voltage

There are two battery systems on the truck: a low-voltage (LV) system and a high-voltage (HV) system.

The right-hand side of the driver display screen shows the state of charge of the HV system.

The LV charging system telltales appear in the upper left corner of the driver display. A yellow telltale indicates a low battery; a red telltale indicates a dangerously low charge.

5.04.08 Speedometer

In the ICC5 the speedometer is shown on the left-hand side of the driver display. The speedometer measures either miles per hour (mph) or kilometers per hour (km/h), depending on the option selected in the system settings.

5.04.09 Primary and Secondary Air Gauges

Primary and secondary air gauges are stacked at the bottom center of the driver display. When the air pressure drops too low, both the air pressure measurement and the air pressure icon change color. A complete lack of air pressure results in only the icon being either amber (caution) or red (danger).

5.04.10 ICC5 Chassis Status Information

In addition to digital instruments and gauges, instrument and infotainment screens provide access to chassis status information such as:

- Tire pressure monitoring
- Axle gear and lock information
- Maintenance information and prompts
- Diagnostic information and fault codes
- List of active driver alerts

5.04.11 Tire Pressure Monitoring System (TPMS)

The tire pressure monitoring system displays tire pressure, temperature, and sensor status. Maintaining correct tire pressure increases fuel economy. Sustained high tire temperature can cause a tire to deteriorate, leading to tread separation and blowouts.

Tire Pressure has three submenu options: tire pressure, tire temperature, and sensor status. Selecting the tire icon image displays a vehicle image on the screen showing the tire pressure for each tire. Tire pressure can be displayed in psi or bar units. The unit of measure is displayed behind the rear left tire on the vehicle image. See Fig.

35, [TPMS: Tire Pressure - ICC5](#). Units of measure are set under Settings.

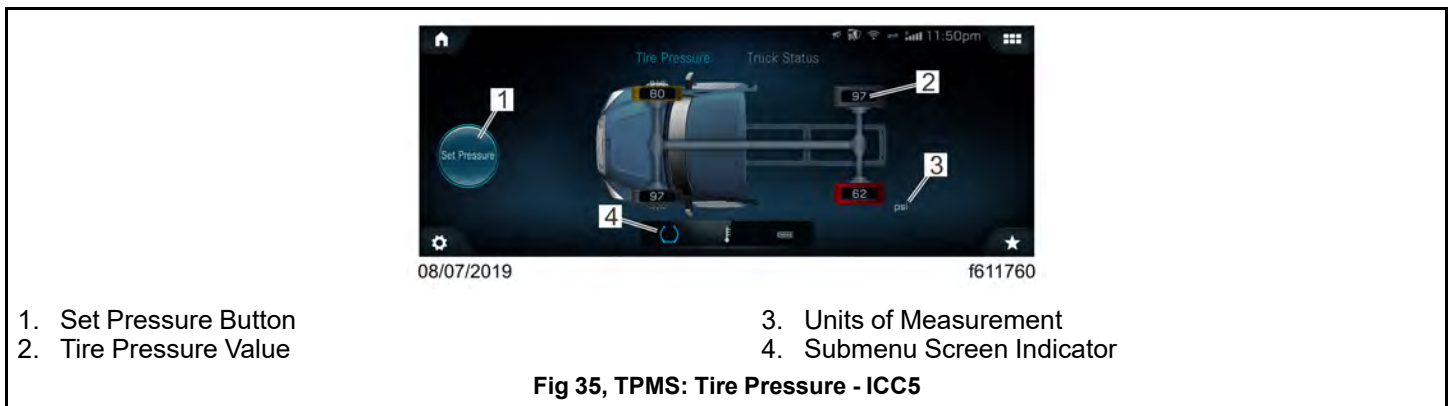

Tires on the truck image change color if tire pressure is too high or too low based on factory settings. Red indicates a condition that may pose a threat to the control of the vehicle. Amber indicates a condition that may result in damage. See Fig. 36, [TPMS: Tire Temperature- ICC5](#).

The option to Set Pressure is available on the tire pressure screen. Selecting this option allows you to change default settings.

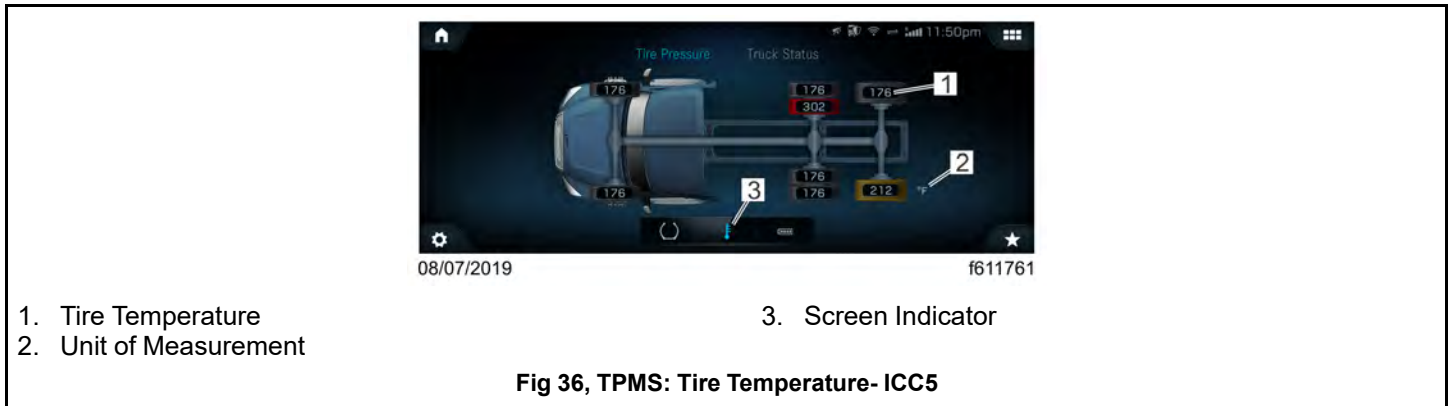

Selecting the temperature icon shows an image of the vehicle on the screen showing the temperature of each tire. Tire temperature can be displayed in Fahrenheit or Celsius. The unit of measure is displayed behind the rear left tire on the vehicle image. Units of measure are set under Settings.

Tires on the truck image change color if tire temperature is too high. Red indicates a condition that may pose a threat to the vehicle. Amber indicates a condition that may result in damage.

Selecting the battery icon shows the battery strength of each tire sensor.

If a sensor's battery life is low, both the tire and the sensor icon on the truck image change color to amber. If sensor battery status is critically low they become red. See Fig.37, [TPMS: Sensor Status - ICC5](#).

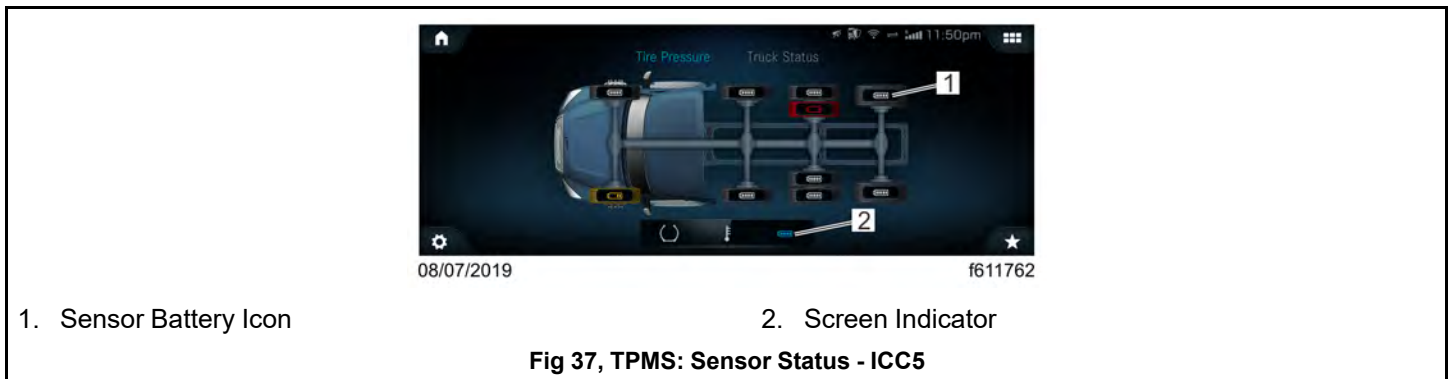

5.04.12 Axles

This menu provides access to the axle locks status screen showing engaged locks and allows the driver to lock or unlock the axles by touching the screen.

For more information see [16.01 Before Checking the Headlight Aim](#), eAxles.

5.04.13 Diagnostics

The Diagnostics screen communicates fault codes and other diagnostic information about the vehicle.

Fault codes are color-coded to indicate the severity of the fault. Red indicates a condition that may pose a threat to control of the vehicle. Amber indicates a condition that may result in damage to vehicle components or derating of motor power. Grey indicates a condition that may affect vehicle handling.

5.04.14 Active Driver Alerts

The Active Driver Alerts screen stores the current active alerts.

Alerts are color-coded to indicate severity. Red indicates a condition that may pose a threat to control of the vehicle. Amber indicates a condition that may result in damage to vehicle components or derating of motor power. Grey is used for notices.

5.04.15 Instrument and Infotainment Screen Controls

In addition to the features described above, the instrument and infotainment screen provides access to a number of digital switches and ICC5 system settings. Under the Cab menu this includes:

- Digital Switches
- Lighting
- Settings

5.04.16 Digital Switches

Digital switches can be used to turn different vehicle functions on or off. An indicator at the top of the digital button shows the status of the switch. A red line indicates the switch has been selected.

5.04.17 Lighting

The lighting menu provides controls for a set of interior and exterior lights using the touch screen.

Exterior Lighting

The exterior lighting screen presents an image of the front of a vehicle showing lights and digital switches for those lights. Touching a switch lights up the switch, activates the lights on the image of the truck, and turns on that light on the truck itself; touching the switch again turns all these lights off.

Touching the intelligent high-beam headlights control at the bottom of the screen changes its status. For this switch the status of On is indicated by a lighted bar at the top of the icon.

When intelligent high-beam headlights are on, the high-beam headlights switch to low-beam headlights when a vehicle approaches from the opposite direction. They switch back to high-beam headlights when no vehicles are approaching from the opposite direction.

The intelligent headlights can also be controlled by using the headlight switch and turn signal lever; see [6.01 Steering Wheel Pods](#), Driver Controls for more information.

Touching the courtesy lighting icon opens a pop up showing the current lighting duration and allowing the lighting duration to be adjusted.

Exterior lighting controlled by the rotary dial cannot be controlled through the exterior light screen.

Interior Lighting

The interior lighting menu shows an image of an interior of a cab. The digital switches for interior lighting allow for the control of overhead, foot well, and sleeper lights.

Touching any of the light icons on the screen lights up the digital switch, activates the lights on the interior image of the truck, and turns on those lights in the truck itself.

All interior lights can be dimmed using the slider next to the light icon.

All available lights in the cab can be turned off and on by touching the Off button.

Entrance lighting can be controlled by the settings icon. Touching the settings icon opens a pop up window where the entrance lighting can be toggled off or on and entrance light timing controls can be accessed. Choosing entrance light timing opens a slider that allows modification of the length of time the entrance light is on.

5.04.18 Settings

The settings menu allows you to choose system features such as display language, units of measurement, and sound levels.

Tap on the settings (gear) icon in the lower left hand corner of the infotainment screen to access Settings. Settings can also be accessed under the Cab menu.

NOTE: Settings options change based on the features installed on the vehicle.

Settings: Language

Language options currently include English (American), Français (Canadian), and Español (Mexican).

Settings: Units

NOTE: Setting a Distance unit to either imperial (miles) or metric (kilometers) auto-populates the Consumption to the same system of measurement.

Units refers to units of measurement and are selected using an either/or radio buttons in each category.

Units are set for Speed (km/h or mph), Fuel Consumption (1/100km or mpg), and Distance (kilometers or miles). Other units include:

- Following Distance: either distance or time
- Pressure: either kPa or PSI
- Temperature: either Celsius or Fahrenheit

Settings: Brightness

Brightness levels for the instrument display, infotainment display, and the dash can be adjusted here using touch-screen slider controls.

Settings: Key Alert

This setting turns the audible lock alert on or off.

Settings: Display Off and On

Selecting this setting turns the display off. Touching anywhere on the display screen turns it on again.

Settings: Controls

Controls provides the ability to change keyboards to accommodate different languages and scripts as well as change the sensitivity levels of touch controls. Touch control settings include slow, medium, and fast.

Audible system feedback controls can also be accessed here as well as under audio settings.

Settings: Audio

Audio Settings control the volume of navigation and traffic announcements, audible system feedback, and phone ringtone and speech volume.

Audible system feedback setting choices include normal, loud, and off. All other audio settings provide touch-screen slider controls to set volume.

Settings: Licence Activation

License Activation lists all activated software licences with activation and expiration dates.

Settings: Reset

The Reset option under Settings allows you to delete all data from the system.

Driving Assistance Settings

The Driving Assistance menu is only available if at least one driving assistant setting is available.

The Driving Assistance menu in Settings allows you to turn available features on or off and/or change setting parameters.

Possible Driving Assistance menu options include:

- Side Guard Assist
- Traffic Sign Display
- eCoast

5.04.19 Climate Control Information

NOTE: See [10.01.01 General Information Cab Features](#), for detailed climate control panel operating instructions.

Climate control information briefly appears on the touch screen display whenever the physical climate controls are adjusted.

5.05 Infotainment Controls

5.05.01 Phone Connection Overview

Connectivity

Connectivity settings control the on or off status of the following features:

- Bluetooth
- NFC (Near Field Communication)
- Wi-Fi

Active and authorized devices will have an options menu (opened by selecting the three dots to the right of a device name) to manage device call logs, contacts, and deauthorization.

Up to two phones can be active and connected via Bluetooth.

Bluetooth

Bluetooth is a wireless technology standard for exchanging data over short distances, typically less than 33 feet (10 m).

A phone connected via Bluetooth will disconnect from the system when taken far enough away from the vehicle or turned off. It will automatically reconnect when in range of an active system if it has not been deauthorized.

Device Manager

Under the Device Manager menu you can:

- Connect a new device
- See a list of active and authorized devices
- Control transmission volume
- Control reception volume
- Deauthorize a device

The last three options can be accessed by selecting the three dots to the right of the device name. Both the reception and transmission volume consist of a slider control with a range of -2 to 2.

5.05.02 Connecting and Disconnecting a Phone Using Bluetooth®

General Information

You can connect or authorize a mobile device such as a smartphone to interact with the ICC5 infotainment system through the Phone menu.

Up to fifteen mobile phones can be authorized at a time.

NOTE: The Smartphone menu is for connecting a device via MirrorLink®, Android Auto™ or Apple CarPlay™.

Requirements:

- Bluetooth is activated on the mobile phone.
- The phone is visible to Bluetooth.
- Bluetooth is activated on the infotainment system.

Activating Bluetooth®

1. Open Settings by selecting the gear shortcut icon in the lefthand corner of the screen.
2. Select Connectivity.
3. Make sure Bluetooth is turned on.
4. Make sure Bluetooth is active on the phone and the phone is visible via Bluetooth.

Connecting a Phone Using Bluetooth®

1. Open the Device Manager.
2. Select Connect Device.
3. Select Connect New Device. The vehicle searches for the device.
4. If the connection fails, the message My Device Was Not Found will appear. Verify the Activating Bluetooth requirements have been met.
5. Select the My Device Was Not Found message or press the reload icon at the top right to have the vehicle rescan for devices.
6. When a device is found, the name of that device will appear on the screen in addition to the message My Device Was Not Found. Select the device name.
7. A pop-up will appear asking for verification of a passkey on the phone. Verify the passkey. The device is authorized and connected.

The Phone Menu

Once a phone is authorized and connected, a mobile phone menu for that phone is available.

In addition, the call list and contacts of the primary phone are loaded and accessible.

The phone menu provides a search function for the primary phone's contacts, a number pad for calling people not in the contact list, and access to Bluetooth and phone specific settings.

Connecting a Second Phone

Connecting a second phone follows the same process as connecting the initial phone, however the call list and contacts of the second phone are not loaded.

1. Open the Device Manager.
2. Select Connect Device.
3. Select Connect New Device. The vehicle searches for the device.
4. When a device is found, the name of that device will appear on the screen in addition to the message My Device Was Not Found. Select the device name.
5. A pop up will appear asking for verification of a passkey on the phone. Verify the passkey. The device is authorized and connected.

Two Phone Mode

In two phone mode, the primary mobile phone can access the phone's contact and call list on the infotainment system and make outgoing calls and receive incoming calls; the secondary mobile phone can receive incoming calls.

Switching Primary and Secondary Phones

1. Open the Phone menu.

2. Select the icon showing two phones. The primary and secondary phone are switched.

Changing Phone Specific Settings

1. Open the Phone menu. The primary active phone's name should display in the upper left.
2. Select the gear icon to access the setting for the phone. The Options screen appears.
3. Choose which of the following options to change:
 - Synchronize Contacts Automatically
 - Synchronize contacts: this options is only available if Synchronize Contacts Automatically is turned off.
 - Delete Contacts: deletes all contacts downloaded from the active phone. Only available if Synchronize Contacts Automatically is turned off.
 - Delete Call List: deletes the call list downloaded from the active phone.
 - Name Format: names may be displayed as Last, First; Last First; or First Last.
 - Bluetooth: Access Device Manager to connect a new phone, deauthorize a phone, and control a phone's transmission and reception volume.

Disconnecting a Phone

A phone may disconnect from the system for the following reasons:

- It moves out of range
- It is shut off or otherwise loses power

NOTE: The phone should automatically reconnect when on and in range of an active system it is authorized to connect to. To cancel this automatic pairing, the phone must be deauthorized either on the system or on the phone.

Reconnecting a Phone

If a phone does not automatically reconnect to an authorized vehicle, do the following:

1. Open the Phone menu.
2. Select Connect Device or, if this is not available, select the Bluetooth icon. The Bluetooth Devices menu opens.
3. Find the phone under Authorized Devices and select the phone name. The vehicle will connect with the phone.

Replacing a Phone

Replacing a mobile phone is the same process as connecting a phone.

To deauthorize the mobile phone being replaced, see **Deauthorizing a Phone Through the Phone Menu** in this chapter.

Deauthorizing a Phone Through the Phone Menu

Deauthorizing a mobile phone, either the primary or secondary phone, can be done in via the Phone menu or through system Settings.

1. Open the Phone menu.
2. Select the Bluetooth icon at the bottom of the screen. The Bluetooth Devices menu opens showing a list of active and authorized phones.
3. If necessary, swipe down the screen to see a list of all authorized devices.
4. Select the three dots to the right of the phone to deauthorize. The list of options available for that phone displays.
5. Select Deauthorize. The system asks for verification.
6. Select Yes. The phone is deauthorized.

Deauthorizing a Phone Through Settings

Deauthorizing a mobile phone, either the primary or secondary phone, can be done in via the Phone menu or through Settings.

1. Open the Settings menu by selecting the shortcut icon of a gear in the lower left corner. The system settings menu opens.
2. Select Connectivity. The Wi-Fi & Bluetooth menu opens.
3. Select Device Manager. The Bluetooth Devices menu opens showing a list of active and authorized phones.
4. Select the three dots to the right of the phone to deauthorize. The list of options available for that phone opens.
5. Select Deauthorize. The system asks for verification.
6. Select Yes. The phone is deauthorized.

5.05.03 Using a Mobile Phone

General Phone Information

Calls may disconnect in the following situations:

- Insufficient network coverage
- Lack of free voice channels when you travel into a new transmitter/receiver area (cell)
- Phone SIM card is not compatible with the available network
- The second SIM card of a Twincard mobile phone is already logged onto the network

In addition, voice quality may fluctuate. The infotainment system supports high quality calls in HD Voice®, but this depends on HD Voice® being supported by both the mobile phone in use and the network.

Setting Reception and Transmission Volume

NOTE: A phone must be active to access these settings.

This setting helps ensure optimal speech reception and transmission quality.

1. Open the Phone menu.
2. Select the Bluetooth icon. The Bluetooth Devices menu opens.
3. Select the three dots to the right of the phone to access that phone's options.
4. Select Reception Volume and set the volume.
5. Select the back arrow.
6. Select Transmission Volume and set the volume.
7. Return to the main phone screen by pressing the back arrow or selecting the physical phone button at the bottom of the infotainment screen.

Searching for a Contact and Making a Call

1. Open the Phone menu.
2. Select the magnifying glass icon for Search. A keyboard opens.
3. Start entering the first or last name of a contact or a partial or full phone number. As you type a number will appear next to the icon for the results list showing how many phone contacts have that series of characters.
4. When the number is small enough, select the results list icon to the right of the search box. A results list appears.
5. Select the desired contact. The contact card appears.
6. Select the desired contact phone number. A call is placed.

Starting Phone Voice Recognition

NOTE: When in two phone mode, the phone voice recognition is only available on the primary phone.

Press and hold the Voice button on the right-hand OFN steering wheel pod for at least one second. Phone voice recognition is now available.

Ending Phone Voice Recognition

Press either the Mute Volume or End Call button on the right-hand OFN steering wheel pod. Mobile phone voice recognition has ended.

Making a Call

1. Open the Phone menu. The primary phone menu appears.
2. Select the number pad icon or select Contacts or Call List menu.
 - 2.a If using the number pad, enter a number. Select the green phone receiver icon. The call is made.
 - 2.b If using the Contact's menu, select a contact. The contacts information is shown. Select a phone number. The call is made.
 - 2.c If using the Call List menu, select the phone number. The call is made.

Accepting a Call

There are two ways to accept a call:

- Press the Accept Call button on the right-hand OFN steering wheel pod.
- Select the accept call button on the infotainment screen.

Ending or Rejecting a Call

There are two ways to end or reject a call:

- Press the End Call button on the right-hand OFN steering wheel pod.
- Press the end call button on the infotainment screen.

Putting an Active Call on Hold and Taking it Off Hold

The function and behavior of taking calls on and off hold and accepting and rejecting waiting calls can vary depending on the phone, phone plan, and network provider. If functions and behavior vary from these directions, consult the manufacturer's operating instructions and provider information.

1. Select the active call number. The call is put on hold.
2. Select the active call number. The call is taken off hold.

Accepting a Waiting Call in Single Phone Mode

If there is an incoming call while a call is being conducted, a screen notification is shown. Depending on the mobile phone and network provider, you may also hear a sound.

Tap on the Accept Call button on either the right-hand OFN steering wheel pod or the infotainment screen. The waiting call is now active. The previous call has been put on hold.

Accepting a Waiting Call in Two Phone Mode

If two phone mode is active and the second call is incoming on the secondary phone, you may hear a signal in addition to getting a screen notification and hearing a sound.

NOTE: Accepting an incoming waiting call on the secondary phone while in two phone mode with a call on hold on the primary phone, will end the active call on the secondary phone.

Tap on the Accept Call button on either the right-hand OFN steering wheel pod or the infotainment screen. The waiting call is now active. The previous call has been on hold.

Switching Between Calls

If there is an active call and another call connection has been established, there are two ways to switch back and forth between calls:

- Select the Switch Calls icon of two arrows pointed in opposite directions on the infotainment screen.
- Select the waiting call. The active call is put on hold. The chosen call is active.

NOTE: On some mobile phones, ending the active call will automatically take the call waiting off hold.

Functions Available During a Call

The following functions are available during an active call:

- The microphone: selecting the microphone turns it on or off.
- The number pad: can be used to send Dual Tone Multiple Frequency (DTMF) tones.
- The Transfer to Phone icon: transfers an active hands-free call over to the phone.

5.05.04 Phone Contacts and Call List

Importing Phone Contacts

Phone contacts of the primary phone are automatically imported when a phone is initially connected to the system.

NOTE: Deleting all contacts and turning off Synchronize Contacts Automatically without deauthorizing the phone will cause the phone to reconnect to the system without re-importing the contacts list.

Changing the Format of Contacts' Names

1. Open the Phone menu.
2. Select the gear icon on the bottom of the primary phone's screen. The Options menu opens.
3. Select Name Format. Three name formats appear: Last Name, First Name; Last Name First Name; First Name Last Name.
4. Select the radio button for your choice of name format. The format of the names in the phone contact list is changed.

Turning Off Synchronizing Phone Contacts

Default system behavior is to have contacts on the primary phone automatically synchronize.

1. Open the Phone menu.
2. If in two phone mode, make sure the phone you want to synchronize is the primary phone.
3. Select the gear icon at the bottom of the phone screen. The Options menu opens.
4. Move the radio button to turn off Synchronize Contacts Automatically. Contacts will no longer be synchronized for this phone.

Deleting All Contacts for the Primary Phone

NOTE: A phone must be connected to the infotainment system to access these settings.

Deleting all contacts for the primary phone does not delete the contacts off the phone nor does it delete any of the contacts saved to Favorites. The contacts saved to Favorites can still be accessed and used from the Favorites menu as long as the phone is connected to the infotainment system.

Deauthorizing the phone also does not delete any contacts saved to the Favorites menu. They do, however, become unavailable for use.

Synchronize Contacts Automatically must be turned off to delete contacts. As long as Synchronize Contacts Automatically remains off, the phone can disconnect and reconnect to the system without contacts being reloaded.

1. Open the Phone menu.
2. Select the gear icon on the bottom of the screen for the connected phone. The Options menu opens.
3. Turn off Synchronize Contacts Automatically.
4. Select Delete Contacts. A message asking for verification appears.
5. Select Yes. All contact data for the primary phone is deleted off the infotainment system except for contacts saved to Favorites.

Deleting a Phone's Call List

NOTE: A phone must be connected to the infotainment system to access these settings.

Deleting the call list from the infotainment system does not delete the call list off the phone.

If a phone disconnects and then reconnects to the infotainment system, the phone call list will be reloaded.

1. Open the Phone menu.
2. Select the gear icon on the bottom of the screen for the connected phone. The Options menu opens.
3. Select Delete Call List. A message asking for verification appears.
4. Select Yes. The call list for the primary phone is deleted.

Saving a Contact as a Favorite

1. Open the Phone menu. The screen for the primary phone appears.
2. Open the Contacts. The phone's list of contacts appears.
3. Select the contact you want to add to the Favorites menu.
4. Press and hold on the phone number. The Options menu for the contact appears.
5. Select Create new favorite. A favorite is created.

Saving a Call List Number as a Favorite

1. Open the Phone menu. The screen for the primary phone appears.
2. Open the Call List. The phone's call list appears.
3. Press and hold the phone number you want to add to the Favorites menu. The Options menu for the number appears.
4. Select Create new favorite. A favorite is created.

Renaming a Phone Favorite

Favorites

1. Select the star shortcut icon to open the Favorites menu.
2. Press and hold on an individual favorite. The Options menu for the favorite will open.
3. Select Rename. A keyboard will appear.
4. Type in the new name for the favorite. Select OK. The favorite has been renamed.

Moving a Phone Favorite

The order of the favorites menu can be changed to place frequently accessed favorites on the first screen.

1. Select the star shortcut icon to open the Favorites menu.
2. Press and hold on an individual favorite. The Options menu for the favorite will open.

3. Select Move. The favorites screen will change appearance. A check mark will appear over the chosen favorite and arrows will appear on each side of it.
4. Press on the arrows to move the favorite to either the left or right until it's in the chosen position.
5. Select the check mark on top of the favorite. The favorite's new position is saved.

Deleting a Phone Favorite

1. Select the star shortcut icon to open the Favorites menu.
2. Press and hold on an individual favorite. The Options menu for the favorite will open.
3. Select Delete. The favorite is deleted.

Deleting All Phone Favorites

NOTE: If you delete the phone's contact list, none of the contacts saved to the Favorites menu will be deleted. The only way to delete all phone contacts saved to the Favorites menu is to delete each phone contact favorite individually or reset the Favorites menu.

5.05.05 Radio

General Description

Opening the Radio icon opens the radio home screen with four options across the top: SiriusXM, FM, AM, and WX.

Searching for an AM/FM Radio Station

1. Select either FM or AM at the top of the Radio menu.
2. Select the magnifying glass icon. A keyboard with a search bar opens.
3. Press the 123 to access the number pad. The keyboard changes to numbers and symbols.
4. Enter the first two or three digits of the desired station frequency ID. The number of results shows next to the results list icon to the right.
5. Select the results list icon. A list of radio frequencies displays, i.e. 89.0 MHz, 89.1 MHz, 89.2 MHz, etc.
6. Select the desired frequency. The radio is set to that frequency.

SiriusXM® Radio

Search options include searching for a station by name, category, or browsing the complete list of available stations.

Searching for a SiriusXM® Satellite Radio Stations by Name

1. Select SiriusXM at the top of the Radio menu.
2. Select the magnifying glass icon. A keyboard with a search bar appears.
3. Start typing the name of a known station. The number of stations with that word appears to the right next the results list icon.
4. Select the results list icon. The list of results appears.
5. Select a station. The station starts playing.

Searching for a SiriusXM® Satellite Radio Station by Category

1. Select SiriusXM at the top of the Radio menu.
2. Select the list icon at the bottom of the screen. The SiriusXM menu opens.
3. Select Category. A list of station categories appears.
4. Select the desired category. The Category list of stations in that category appears.

5. Select a station. The station starts playing.

Browsing SiriusXM® Satellite Radio Stations

1. Select SiriusXM at the top of the Radio menu.
2. Select with the list icon at the bottom of the screen. The SiriusXM menu opens.
3. Select SiriusXM. A current station/channel list appears.
4. Select the desired station. The station starts playing.

Adding a Radio Channel to Favorites

Up to twenty different items can be saved to the Favorites menu.

1. Open the Radio icon.
2. Navigate to the desired radio station.
3. Press and hold on the station icon or current album artwork. The Options menu will open.
4. Select Save as Favorite. The station is now a favorite.

Deleting a Radio Station Favorite

NOTE: While Global Favorites are created inside individual applications, they are deleted, moved, or renamed inside the Global Favorites menu. For directions, please see the **Favorites** section in this chapter.

Setting a Radio Station Preset

The infotainment system can save up to 12 radio presets.

1. Open the Radio icon.
2. Navigate to the desired radio station.
3. Press and hold on the station icon or current album artwork. The Options menu will open.
4. Select Add to presets. The station is now a preset.

Saving a Radio Station Preset as a Favorite

A radio station can be saved as both a preset and a favorite.

1. Open the Radio icon.
2. Use the arrows to the right and left of the screen to navigate to the desired preset.
3. Press and hold on the preset. The Options menu opens.
4. Select Save as Favorite. The preset is now also saved under the Favorites menu.

Moving a Radio Preset

Radio station presets can be reordered to move those more frequently accessed to the first screen.

1. Open the Radio icon.
2. Use the arrows to the right and left of the screen to navigate to the desired preset.
3. Press and hold on the preset. The Options menu opens.
4. Select Move. A checkmark appears over the preset with arrows to each side.
5. Press the arrows to move the preset into the desired order.
6. Select the checkmark over the preset. The preset is now saved in its new location.

Deleting a Radio Preset

1. Open the Radio icon.

2. Use the arrows to the right and left of the screen to navigate to the desired preset.
3. Press and hold on the preset. The Options menu opens.
4. Select Delete. The preset is now deleted.

Weather Radio (WX)

Weather Radio displays as WX in the top radio menu.

Weather radio channels WX1 through WX7, corresponding to frequencies 162.400 MHz through 162.550 MHz, are the standard weather radio channels used by NOAA Weather Radio in the United States, Weatheradio Canada/Radiométéo Canada in Canada, and SARMEX in Mexico. Each system consists of a nationwide network of radio stations broadcasting official weather warnings, watches, advisories, forecasts and other non-weather related hazard information including news on natural disasters (earthquakes, avalanches, floods), environmental hazards (oil spills, chemical releases), and public safety messages (AMBER alerts, network outages). All services operate 24 hours a day, 7 days a week.

The average range for reception from a transmitter is approximately 40 miles (60 km). The National Weather Service operates more than 1000 transmitters.

Displaying AM/FM/WX Emergency Warnings

1. Select the gear icon at the bottom of the AM, FM, or WX radio screen. The Options menu for that application opens.
2. Turn on or off Display Emergency Warnings.

5.05.06 Sound System Settings

Adjusting the Volume

Volume can be increased or decreased by pressing the '-VOL' or '+VOL' buttons below the infotainment screen or by using the 'VOL+' or 'VOL-' buttons on the OFN steering wheel switch pod.

Muting and Unmuting the Radio

The global Radio menu has an icon of a speaker with a line through it. Press this icon to mute the radio. The radio mutes. The icon image changes to a speaker playing music.

To unmute the radio select the icon of the speaker playing music. The radio starts playing. The icon image changes to a speaker with a line through it.

Muting and Unmuting Media Devices

To mute or unmute audio playback from media devices you can increase or decrease the volume or halt media playback.

Play of media devices can be halted via the Media menu by selecting the pause button. Restarting media playback may be done by selecting the play button on the Media menu.

Bluetooth streaming may require restarting playback on the connected device.

5.05.07 Accessing Sound Settings

Sound settings are global settings for all audio sources and provide access to the equalizer and balance controls as well as the on/off controls for automatic volume amplification.

1. Select the gear icon at the bottom of the screen in an audio application. The Options menu for that application opens.
2. Select Sound. The Sound menu opens.
3. Select the sound setting to manipulate. The Equalizer menu or Balance menu opens.
4. Select and move the control along the slider(s) available. The sound settings have been changed.

5.05.08 Favorites

General Information

The Favorites menu offers quick access to frequently used phone numbers and radio stations. It can be accessed by selecting the star shortcut icon at the bottom right of the infotainment screen.

Favorites are created from inside different applications. For directions on saving a phone contact to the Favorites menu, see **Saving a Contact as a Favorite** in this chapter. For directions on saving a radio station to the Favorites menu, see **Adding a Radio Channel to Favorites** in this chapter.

It is possible to create up to twenty favorites.

Renaming Favorites

1. Tap on the star shortcut icon to open the Favorites menu. Saved favorites are displayed.
2. Press and hold on the icon for a favorite. The Options menu appears.
3. Select Rename. A keyboard appears.
4. Enter the new name. Select OK. The favorite has been renamed.

Moving Favorites

Favorites can be reordered to move the most popular to the first screen of the Favorites menu.

1. Tap on the star shortcut icon to open the Favorites menu. Saved favorites are displayed.
2. Press and hold on the icon for a favorite. The Options menu appears.
3. Select Move. The selected favorite now has a checkmark over it and arrows at each side.
4. Press on either the right or left arrow to move the favorite into the desired position.
5. Select the checkmark. The favorite has been saved in its new position.

Deleting Favorites

1. Tap on the star shortcut icon to open the Favorites menu. Saved favorites are displayed.
2. Press and hold on the icon for a favorite. The Options menu appears.
3. Select Delete. The favorite is now deleted.

Deleting All Favorites

1. Tap on the star shortcut icon to open the Favorites menu. Saved favorites are displayed.
2. Select the word Reset at the bottom of the Favorites screen. The Reset verification pop-up will appear.
3. Select Yes. All favorites are deleted.

5.05.09 Media

General Information

The vehicle infotainment system is capable of playing music from a phone, USB drive, or other device. The vehicle has two USB2 ports to connect devices. Devices can also be connected to the system via Bluetooth.

If an authorized phone is connected to the system via Bluetooth when the Media menu is opened, the infotainment system should automatically start streaming that music.

Playing Audio Off a Phone or Other Device

Selecting a different audio source than the one active turns off the music. You may need to restart the music on the device when returning to the original audio source to get the music to play.

1. Open the Media menu.
2. Select the audio source: Bluetooth, USB1, or USB2.
3. If necessary, select the music to play. Music starts playing through the vehicle speakers.

5.05.10 Smartphone

NOTE: Apple CarPlay, Android Auto, and MirrorLink should **not** be used for navigation for a truck or bus, as both lack the ability to take vehicle-based route restrictions into account.

Apple CarPlay™

Apple CarPlay allows a driver to use an iPhone to make calls, send and receive messages, listen to music, and get directions.

Apple CarPlay can connect to the system via a USB2 cable or Bluetooth.

Android Auto™

Android Auto allows the driver to use an Android phone to make calls, send and receive messages, get information, listen to music, and get directions.

Android Auto requires that a smartphone be connected to the system via a USB2 cable.

MirrorLink®

MirrorLink allows a driver to use any MirrorLink enabled smart phone to get directions, listen to music, and use smart phone applications.

MirrorLink uses huge icons that allow for the control of smart phone features without getting distracted from the task of driving.

5.06 Clock Settings

Time and Date

Clock settings are found under the Settings menu.

Time and Date Settings

The correct time and date is required for the following features to work:

- Alarm clock
- Navigation guidance with time-dependent traffic routing
- Calculation of the expected time of arrival
- Maintenance
- Prognostics

NOTE: Time and date are set automatically when the vehicle is equipped with a tachograph. When a vehicle is equipped with a tachograph only the time zone can be changed.

The following settings can be controlled under 'Time and Date:' selecting a time zone, turning 'Automatic Summer Time' on or off, turning 'Summer Time' on or off, and setting the date and time format.

'Automatic Summer Time' is another name for automatic daylight saving time. If this is set to on then the controls for 'Summer Time' are unavailable.

Dates can be displayed as: DD.MM.YYYY, MM/DD/YYYY, or YYYY/MM/DD. Selection is made using either/or radio buttons.

Time can be displayed in 12 AM/PM or 24 hour format.

Alarm Settings

Alarm Clock Controls and Features:

- Time of Day
- Repeat
- Audio Source
- Light Alarm

Tapping on a bar at the bottom of the screen in the alarm clock menu switches between alarm clocks and the sleep timers. If alarms have been set, the corresponding icon in the bar indicates this with the number of active alarms shown inside a circle.

Up to fifteen alarms can be shown in a carousel view on the screen. They are sorted from the beginning of the day on the left and the end of the day on the right. If less than fifteen alarms have been set, an 'Add Alarm' icon is available in the carousel display at the far right. If fifteen alarms have been created, the 'Add Alarm' icon is not available.

New alarms are set to be 'On' when created. Alarms can be toggled off and on by pressing on an alarm tile. An active alarm has a red line at the top of the alarm tile.

If an alarm has been set to repeat, the selected days of the week is listed below the time.

The audio of an alarm can be set under 'Audio Source.' Options include up to 15 preset alarm sounds and any available radio station.

If an alarm includes turning on lights, a light icon is shown on the alarm tile at the bottom right. Wake up lighting can be set to be turned on at 10 to 100 percent brightness.

Alarms can be edited by pressing on the pencil icon below the alarm tile. To delete an alarm, press on the edit pencil icon and choose 'Delete.'

NOTE: The ability to set the alarm clock and timers is only available when the parking brake is engaged.

5.07 Telltale Warnings and Messages

Telltale warnings appear on the driver display to alert the driver of hazards.

The colors of telltales and warnings indicate the hazard level: red (warning), amber (caution), green and blue (active status), grey (passive status), white (informational). Blue is currently used to indicate an active phone call, that a software download is available, and that utility lamps and high beams are on.

Warnings, Indicators, and Messages Tables

See the following tables for descriptions of what the telltales are signaling, and related messages.

For ePowertrain Telltale Lamps and Messages as shown, see Table 3, [ePowertrain Telltale Lamps and Messages](#).

For Braking and Traction Telltale Lamps and Messages as shown, see Table 4, [Braking and Traction Telltale Lamps and Messages](#).

For Detroit Assurance Telltale Lamps and Messages as shown, see Table 5, [Detroit Assurance Telltale Lamps and Messages](#).

For Coolant Level Telltale Lamps and Messages as shown, see Table 6, [Coolant Level Telltale Lamps and Messages](#).

For Steering Telltale Lamps and Messages as shown, see Table 7, [Steering Telltale Lamps and Messages](#).

For Driving Safety Related Icons as shown, see Table 8, [Driving Safety Related Icons](#).

For Tire Pressure Monitoring System Telltales and Messages as shown, see Table 9, [Tire Pressure Monitoring System Telltales and Messages](#).

For Passenger Safety Telltale Lamps and Messages as shown, see Table 10, [Passenger Safety Telltale Lamps and Messages](#).

For Exterior-Lamps Telltale Lamps and Messages as shown, see Table 11, [Exterior-Lamps Telltale Lamps and Messages](#).

For Outside Ambient Temperature Icon, as shown, see Table 12, [Outside Ambient Temperature Icon](#) .

For ICU Application Icons as shown, see Table 13, [ICU Application Icons](#).











Telltale	Color	Description		Related Messages
	Blue	Charger Connected to Vehicle	A flashing telltale indicates the vehicle is actively charging. Solid illumination indicates the desired SOC has been reached and that the charger is connected to the vehicle.	When a charging coupler is plugged into the vehicle, the vehicle's ability to drive is inhibited.
	Blue	Powertrain Active	Signals that the ePowertrain is activated and the vehicle is ready to drive.	If a door is opened when the parking brake is disengaged and the powertrain is active, a popup appears.
	Amber	Low-Voltage Battery Problem	A low-voltage battery problem has been detected.	
	Red	Low-Voltage Battery Failure	The low-voltage batteries have failed or cannot be detected.	
	White	High-Voltage Battery Charge Normal Operation	The high-voltage batteries have a high enough charge to operate the vehicle.	
	Amber	High-Voltage Battery Charge Low	Indicates an state of charge warning is active. Turn off unneeded features drawing power. Drive the vehicle for 30-60 minutes, or manually charge the low-voltage batteries.	
	Amber	High-Voltage Battery Problem	Indicates a non-critical battery fault, such as one of the high-voltage batteries going offline. Take the vehicle in for service.	
	Red	High-Voltage Battery Failure	A thermal event has been detected inside a high-voltage battery. Bring the vehicle to a safe stop, apply the park brake, turn the keyswitch to off, and exit the cab	The vehicle must be on for the high-voltage battery thermal event detection system to be active.

Table 3, ePowertrain Telltale Lamps and Messages

Telltale	Color	Description		Related Messages
			within the next five minutes. If there is time, press in the eStop button.	
	Amber	ePowertrain problem	A high-voltage battery or ePowertrain problem has been detected. A derate program has been activated or the driving range has been reduced. Take the vehicle in for service.	
	Red	ePowertrain Error	A high-voltage battery or ePowertrain problem has been detected. Stop immediately.	
	Amber	eDrive problem	An eDrive problem has been detected	
	Red	eDrive error	And eDrive error has been detected	





















Telltale Lamp	Color	Description		Related Information
	Green	Recuperative Braking	Indicates recuperative braking has been activated by moving the right-hand multifunctional control stalk into position 1, 2, or 3 (low, medium, or high).	A blue line will appear on the charge portion of the power gauge showing the amount of available recuperative braking requested.
	Green	Descent Control Mode	Indicates descent control mode is active.	The driver should always be ready to intervene by applying the service brakes. On steep roads recuperative braking may not be able to maintain the vehicle set speed.
	Amber	Hill Start Aid Disengaged	A blinking telltale indicates hill start aid is inactive. A solid telltale indicates a fault with the system.	To turn on HSA, press the HSA OFF switch again or cycle the vehicle keyswitch.





Table 4, Braking and Traction Telltale Lamps and Messages



Telltale Lamp	Color	Description		Related Information
	Grey	Brake Hold Mode Engaged	Indicates brake hold mode is active. The service brake will be maintained when the driver takes their foot off the brake pedal.	Brake hold mode is released when the accelerator pedal is pressed, the work brake is set, or the park brake is set.
	Red	Park Brake Engaged	Indicates the park brake is engaged.	Always engage the park brake before exiting the vehicle.
	Red	Low Brake Air Pressure	Indicates air pressure in the primary or secondary reservoir has dropped below approximately 70 psi (483 kPa). Bring the vehicle to a safe stop and have the air system repaired before continuing.	A buzzer will sound if the park brake is released or the vehicle is moving when the air pressure has dropped below 70 psi.
	Amber	Tractor Anti-Lock Braking System (ABS)	Momentary illumination indicates the vehicle ABS is engaged. Solid illumination indicates a problem with the vehicle ABS. Repair the ABS to ensure full braking capability.	Even if the ABS is completely inoperative, normal braking ability is maintained.
	Amber	Automatic Traction Control (ATC) Active	A flashing telltale lamp indicates a wheel spin event has been detected, and the ATC system is active.	
	Amber	Automatic Traction Control (ATC) Deactivated	Indicates the ATC SPIN switch has been pressed to allow wheel slip.	Press the switch again to active ATC.
	Red	Brake System Warning	Solid telltale. Indicates a failure in the Antilock Braking System/ Electronic Braking System (ABS/EBS) or the electronic air processing unit (EAPU). Stop the vehicle and call for service.	





Telltale	Color	Description		Related Messages
	Green	Adaptive Cruise Control (ACC) Active	Indicates that adaptive cruise control is on and active.	
	Amber	Adaptive Cruise Control Unavailable	Indicates that Adaptive Cruise Control (ACC) is not available	
	Amber	Active Brake Assist Unavailable	Indicates the Active Brake Assist system is not available.	
	Amber	Lane Departure Warning Unavailable	Indicates that lane departure warning is disabled due to minimum speed, lack of lane markings, or system not being available.	
	Blue	Lane Keep Assist (LKA) Active	Lane Keep Assist is on and making micro-steering adjustments to keep the vehicle in the preferred lane position.	When Lane Keep Assist is off there is no steering wheel telltale. Lane Keep Assist (LKA) is a component of Active Lane Assist (ALA).
	Grey	Lane Keep Assist (LKA) on but inactive	Lane Keep Assist is on but inactive. Reasons for inactivity include: <ul style="list-style-type: none"> • Lane markings cannot be identified. • There has been a significant change in load with the ignition switched on. 	If Adaptive Cruise Control (ACC) is not available, Active Lane Assist (ALA) is not available. Lane Keep Assist (LKA) is a component of ALA.
	Red	Auto Stop Active	When Auto Stop activates at the end of the Lane Keep Assist warning cascade, the Auto Stop telltale appears. When Auto Stop has brought the vehicle to a standstill, the Auto Stop telltale clears.	The Auto Stop warning window: "Auto Stop Started Throttle to Cancel" appears when Auto Stop initiates.

Telltale	Color	Description		Related Messages
	Amber	Low Coolant Level	The battery coolant level is low. OR The eDrive coolant level is low. Fill the low cooling system reservoir at the first opportunity.	A pop-up message will specify which coolant level is low.
	Red	Very Low Coolant Level	The battery coolant level is very low. OR The eDrive coolant level is very low. Stop the vehicle and fill the low cooling system reservoir.	A pop-up message will specify which coolant level is low.

Telltale	Color	Description		Related Information
	Amber	Electro-hydraulic Power Steering (EHPS) Error	One reason this telltale appears is if the power to the EHPS pumps exceeds a set current level.	

Telltale	Color	Description	
	Amber	Electronic Stability Control (ESC) Active	Flashing indicates a stability event has been detected, and the ESC system is active. Solid illumination indicates a problem with the stability system. Repair the ESC system immediately to ensure full stability capability.
	Amber	Electronically Controlled Air Suspension (ECAS) Error	Indicates and active ECAS fault.
	Amber	IPPC Error	
	Green	AERO active	Indicates that aerodynamic height control (AERO) is active.

Telltale	Color	Description		Related Messages
	Red	Tire Pressure Monitoring System (TPMS) Warning	At least one tire has very low tire pressure, very high tire pressure, or a high tire temperature.	The TPMS screen will highlight which tire and what the issue is.
	Amber	Tire Pressure Monitoring System (TPMS) Caution	At least one tire has high tire pressure or a TPMS battery is low and needs to be replaced.	The TPMS screen will highlight which tire is affected.

Telltale	Color	Description		Related Message
	Red	Unfastened Seat Belt	Indicates the driver's seat belt is unfastened.	When the system detects that the parking brake is off and the driver seat belt is not fastened an audible alert activates.
	Amber	Supplemental Restraint System (SRS) Error	Indicates a malfunction has occurred in the restraint system and restraint system components may be triggered unintentionally or may not deploy as intended during an accident.	If the SRS telltale appears, have the restraint system checked and repaired immediately.
	White	Left-Hand Door Unlatched	Indicates the left-hand door on two door cab is unlatched.	
	White	Right-Hand Door Unlatched	Indicates the right-hand door on two door cab is unlatched.	
	White	Both Doors Unlatched	Indicates both doors on a two door cab are unlatched.	













Telltale	Color	Description	
	Green	Left-Turn Indicator On	Flashing indicates the left-turn signal lamps are activated.
	Green	Right-Turn Indicator On	Flashing indicates the right-turn signal lamps are activated.

Table 11, Exterior-Lamps Telltale Lamps and Messages

Telltale	Color	Description	
	Blue	High-Beams On	Indicates the high-beam headlights are on.
	Green	Low-Beams On	Indicates the low-beam headlights are on.
	Blue	Automatic High-Beams On	Indicates the high-beam headlights have been set to automatic and are on.
	Grey	Automatic High-Beams Off	Indicates the high-beam headlights have been set to automatic and are off.
	Green	Automatic Low-Beams On	Indicates the low-beam headlights have been set to automatic and are on.
	Grey	Automatic Low-Beams Off	Indicates the low-beam headlights have been set to automatic and are off.
	Green	Taillights / Marker Lamps On	Indicates the taillights, aka marker lamps, are on.

Telltale	Color	Description		Related Pop-Up Message
	White	Snowflake	Indicates ambient air temperature has dropped below 34°F (1°C). Pay attention to road conditions and watch for ice.	<p>ICUC Caution</p>  <p>05/29/2019 f611753a</p>

Telltale	Color	Description		Related Information
	Blue	Active Phone Call	Indicates a phone is connected to the ICU and a call is active.	The phone screen in the infotainment section of the ICU will also show an active call, including the number being called and call length.
	Blue	Software Download Available	Indicates a software download is available. For reasons of security and optimal vehicle functioning, software updates should be quickly installed.	A pop-up message will also appear.

6.01 Steering Wheel Pods	70
6.02 Multifunctional Stalk Switch	70
6.02.01 General information	70
6.02.02 eAxle 2-Speed Transmission Direction Function	70
6.02.03 Driving Program Mode Function	72
6.02.04 Gear Selection Function	73
6.02.05 Recuperative Braking Function	74
6.03 Emergency High-Voltage Disconnect Button	75
6.04 Exterior Lighting Controls	75
6.04.01 General information	75
6.04.02 Exterior Lights	75
6.05 Other Dash Mounted Controls	80
6.05.01 Other Dash Mounted Controls	80
6.05.02 ATC Spin Switch	81
6.05.03 Hill Start Aid Override Switch	82
6.05.04 Air Suspension Height Control Switch	82
6.06 Horn Control	83
6.06.01 Electric Horn	83

6. Driver Controls

6.01 Steering Wheel Pods

The left-hand steering wheel pod has switches for the cruise control, a marker-lamp-interrupt switch, and the quick-access screens. The right-hand steering wheel pod has switches for infotainment features.

Both switch pods have a menu button in the center of the pod to navigate features and screens. Swipe a finger to the left or right over the light in the menu button to page through screens and make menu selections. An audible click is heard when the finger motion is read. See Fig. 38, [Steering-Wheel Pods](#).

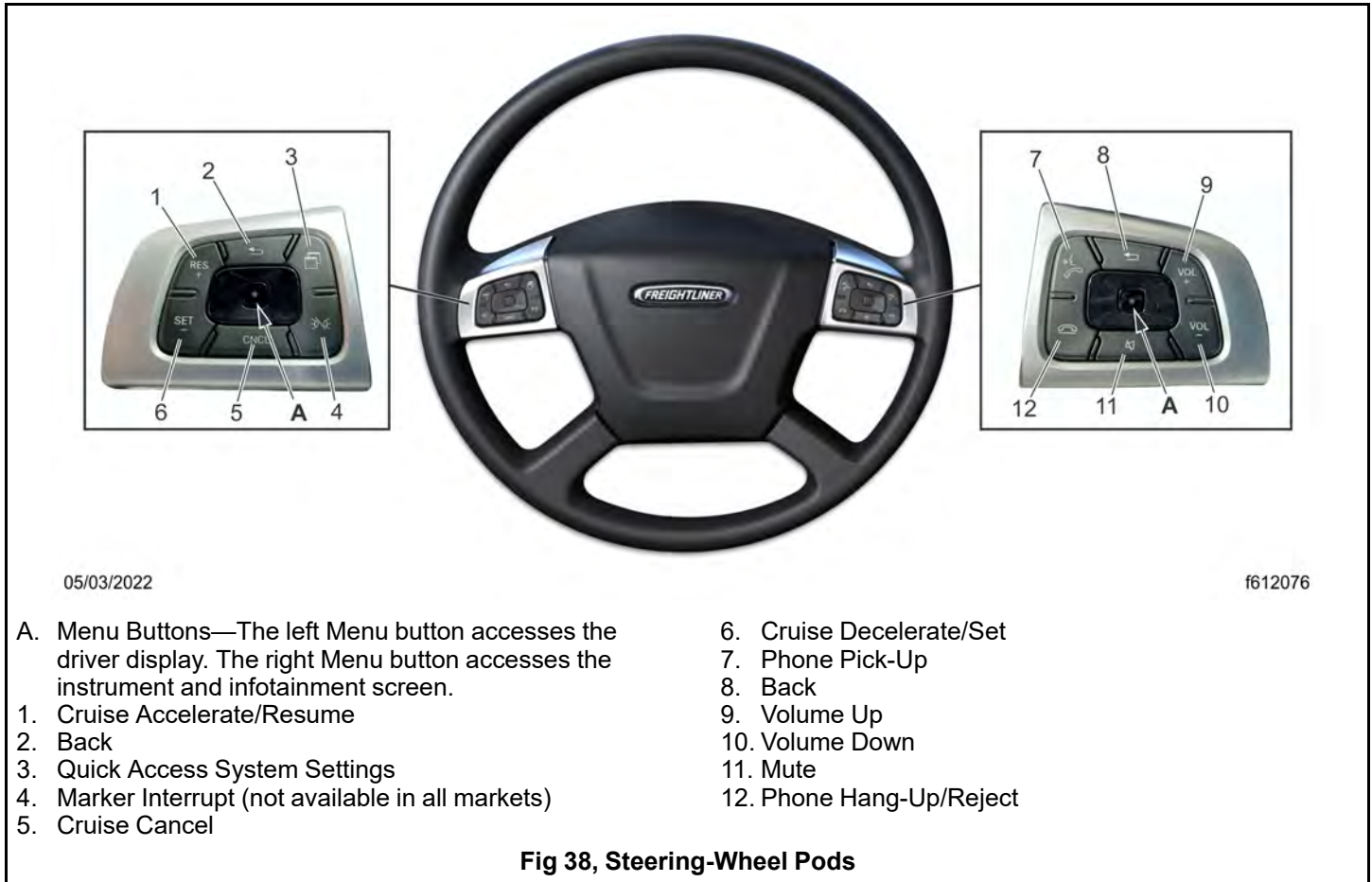

6.02 Multifunctional Stalk Switch

6.02.01 General information

The multifunctional stalk switch, located on the right-hand side of the steering column, is used to select the direction function of the transmission, driving modes, upshifting or down shifting, and recuperative braking.

6.02.02 eAxle 2-Speed Transmission Direction Function

Use the eAxle transmission direction function on the switch to select drive (D), neutral (N), or reverse (R). See Fig. 39, [eAxle 2-Speed Transmission Shift Control](#), ref. A.

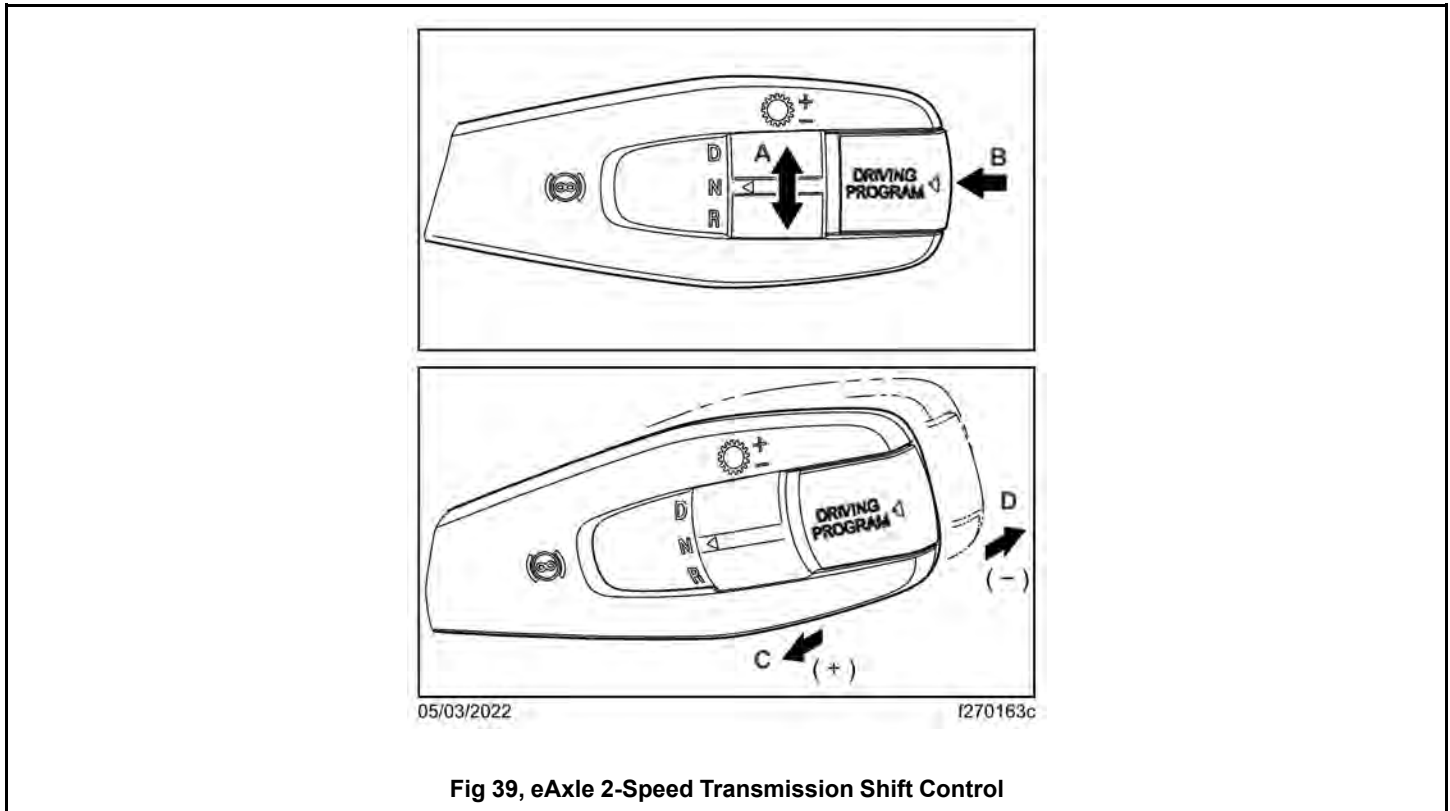

Fig 39, eAxle 2-Speed Transmission Shift Control

See Table 14, [Functionality, eAxle 2-Speed Transmission Shift Control](#) for a description of control functionality.

1. Rotate direction switch to select drive (D), neutral (N), or reverse (R).
2. Short press to switch between available driving modes. Long press to switch between manual and automatic mode
3. Pull for upshift (+) request.
4. Push for downshift (-) request.

Function/Switch	Action/Position	Request
Direction	D	Forward gears
	N	Neutral
	R	Reverse gear
Mode	Short press	Switch between available driving modes
	Long press	Switch between manual and automatic mode
Gear	Short pull on the lever	Upshift, single gear
	Short push on the lever	Downshift, single gear

Table 3, Functionality, eAxle 2-Speed Transmission Shift Control

6.02.03 Driving Program Mode Function

The driving program modes of Economy, Range, and Performance can be selected using the driving program function on the multifunctional stalk switch. See Fig. 40, [eAxle 2-Speed Transmission Shift Control](#), ref. B. See [12.01.01 General Information](#), under Driving Modes and Energy Efficiency, for details of the driving modes.

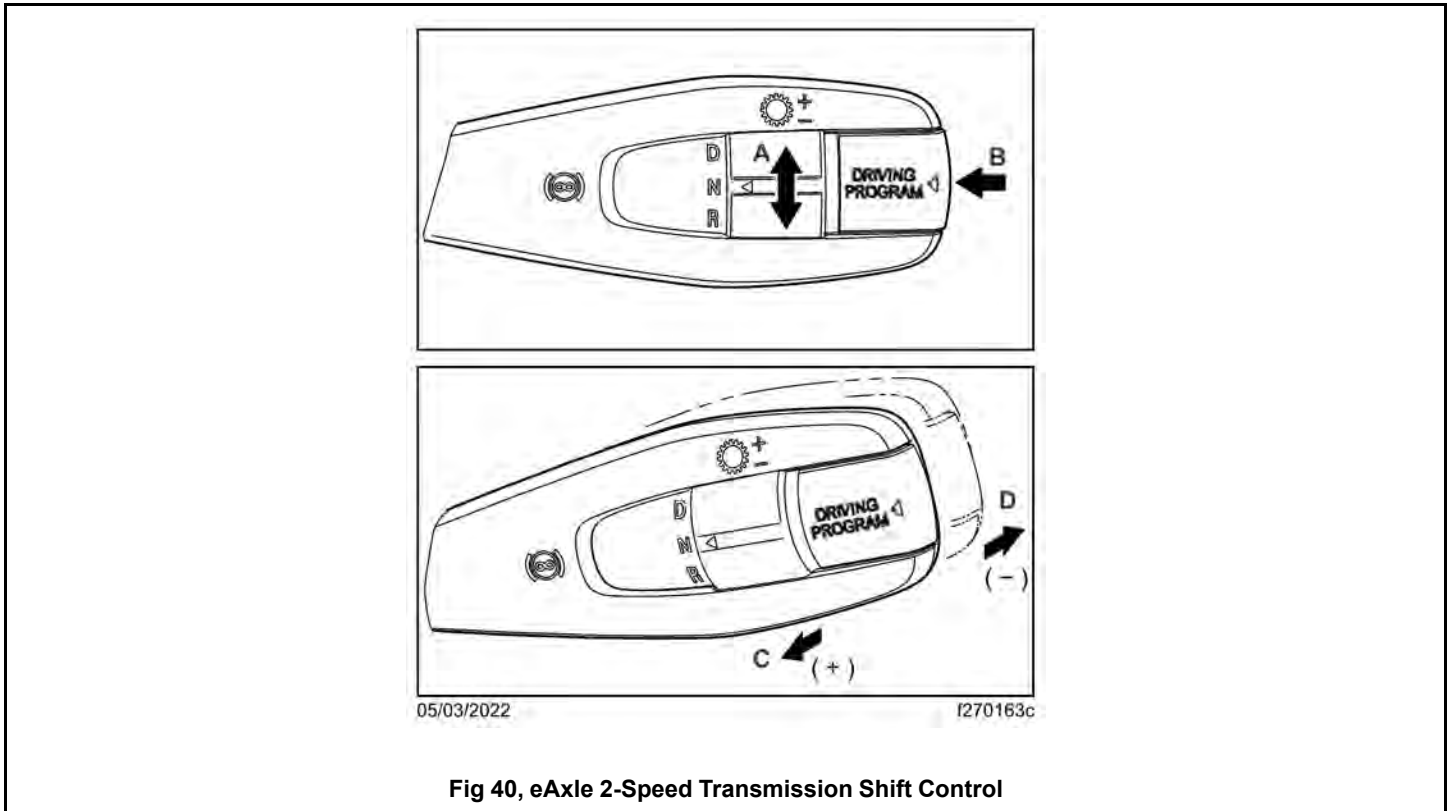

Fig 40, eAxle 2-Speed Transmission Shift Control

See Table 15, [Functionality, eAxle 2-Speed Transmission Shift Control](#) for a description of control functionality.

1. Rotate direction switch to select drive (D), neutral (N), or reverse (R).
2. Short press to switch between available driving modes. Long press to switch between manual and automatic mode
3. Pull for upshift (+) request.
4. Push for downshift (-) request.

Function/Switch	Action/Position	Request
Direction	D	Forward gears
	N	Neutral
	R	Reverse gear
Mode	Short press	Switch between available driving modes
	Long press	Switch between manual and automatic mode

Table 15, Functionality, eAxle 2-Speed Transmission Shift Control

Function/Switch	Action/Position	Request
Gear	Short pull on the lever	Upshift, single gear
	Short push on the lever	Downshift, single gear

Table 4, Functionality, eAxle 2-Speed Transmission Shift Control

6.02.04 Gear Selection Function

Push the lever away from you to request a downshift, or pull the lever toward you to request an upshift. See Fig. 41, [eAxle 2-Speed Transmission Shift Control](#), ref. C and D. See [15.01.01 Gear Display](#) for more information on the eAxle 2-speed transmission.

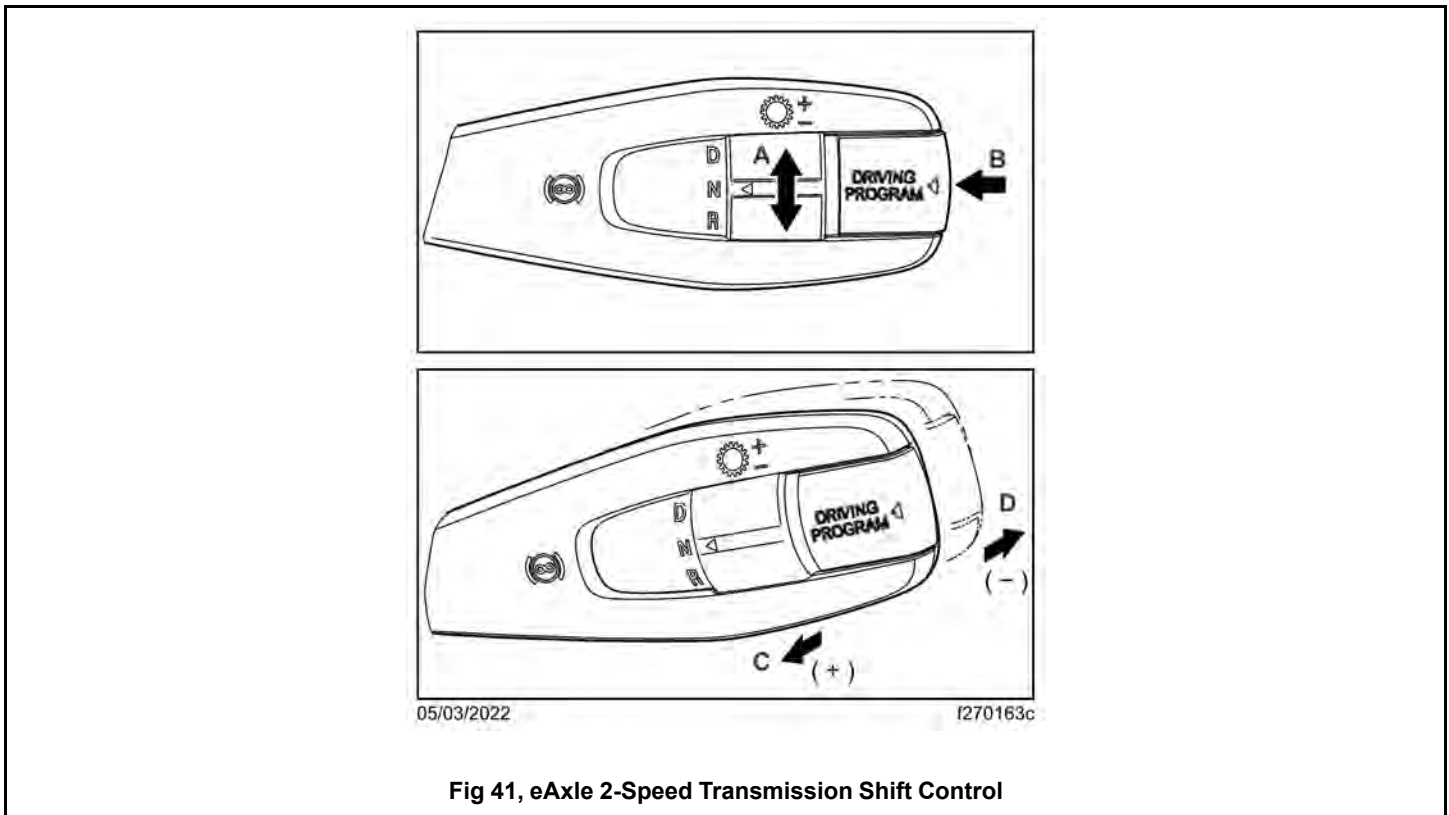

Fig 41, eAxle 2-Speed Transmission Shift Control

See Table 16, [Functionality, eAxle 2-Speed Transmission Shift Control](#) for a description of control functionality.

1. Rotate direction switch to select drive (D), neutral (N), or reverse (R).
2. Short press to switch between available driving modes. Long press to switch between manual and automatic mode
3. Pull for upshift (+) request.
4. Push for downshift (-) request.

Function/Switch	Action/Position	Request
Direction	D	Forward gears

Table 16, Functionality, eAxle 2-Speed Transmission Shift Control

Function/Switch	Action/Position	Request
	N	Neutral
	R	Reverse gear
Mode	Short press	Switch between available driving modes
	Long press	Switch between manual and automatic mode
Gear	Short pull on the lever	Upshift, single gear
	Short push on the lever	Downshift, single gear

Table 5, Functionality, eAxle 2-Speed Transmission Shift Control

6.02.05 Recuperative Braking Function

The multifunctional stalk switch is also used to activate recuperative braking. Select position one through three as shown, see Fig. 42, [Multifunctional Stalk Switch Positions, Recuperative Braking](#) . The recuperative braking telltale as shown, see Fig. 43, [Recuperative Braking Telltale](#) appears on the driver display. See [13.01 Recuperative Braking](#) for more information regarding recuperative braking.

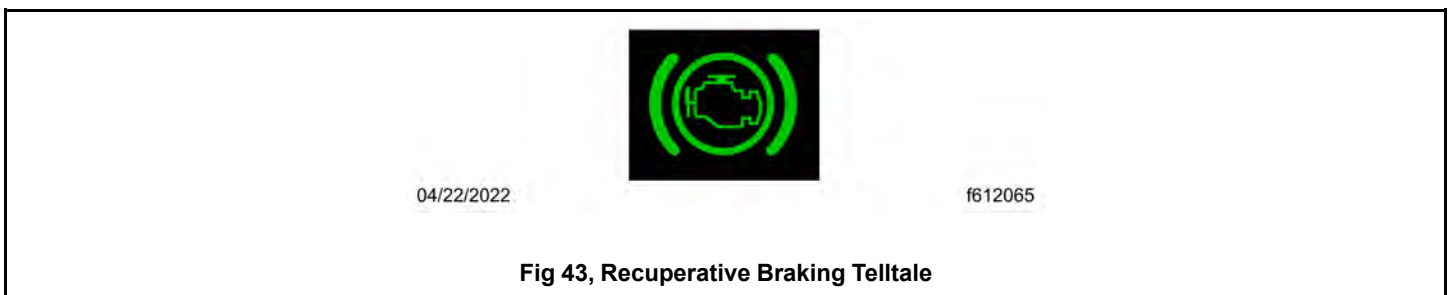
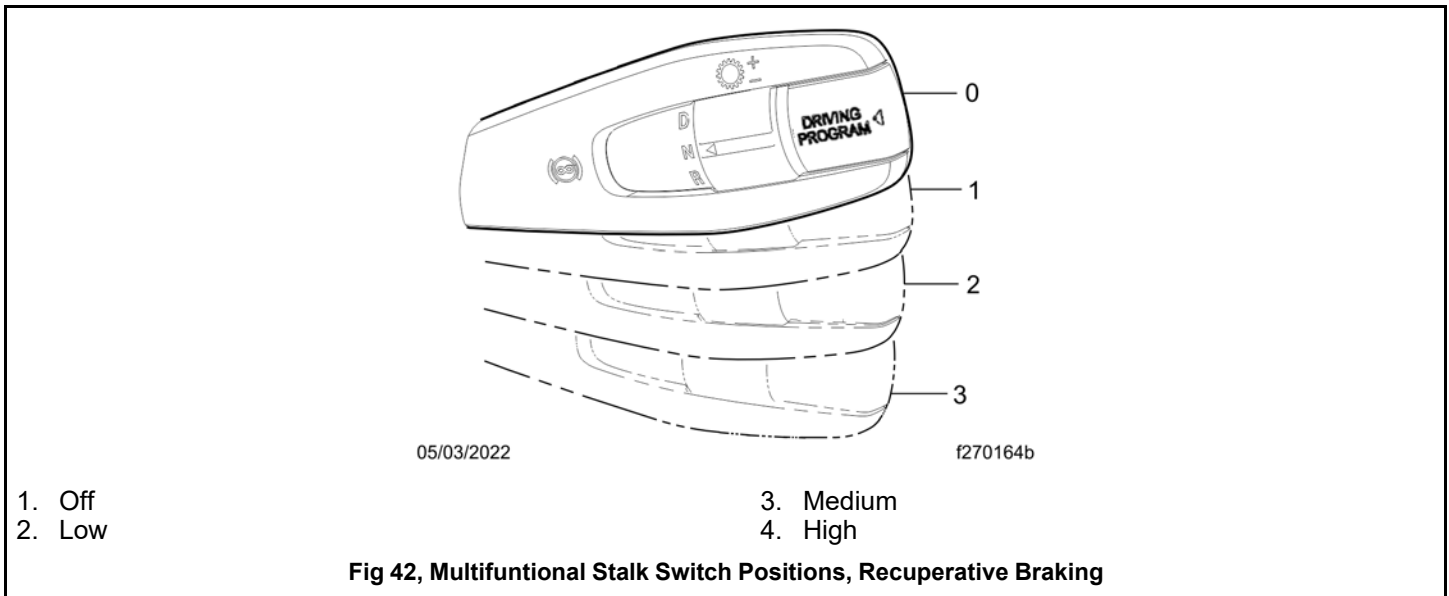

6.03 Emergency High-Voltage Disconnect Button

Pressing the red emergency high-voltage disconnect button shown in Fig. 44, [Truck Lower Dash Controls](#), also called the eStop button, immediately disables the high-voltage system by stopping the flow of power to and from the high-voltage batteries.



- | | |
|--------------------------------|---|
| 1. Parking Brake Knob | 3. Power Outlet |
| 2. Hazard Warning Light Switch | 4. Emergency High-Voltage Disconnect Button |

Fig 44, Truck Lower Dash Controls

The eStop button is surrounded by a yellow switch guard to protect it from being inadvertently pressed. Affixing a lock through the yellow switch guard stops the red button from popping out after it is intentionally pressed.

To release the button and resume the flow of power, remove any attached lock and spin the button to either the left or right.

6.04 Exterior Lighting Controls

6.04.01 General information

Exterior lamps may be controlled by vehicle inputs or switches or both. Some lamps only function when other lamps are on.

Dash-mounted switches are backlit to illuminate both the text and icon on the switch. Press the upper half of the switch to turn the desired lamp(s) on or off.

6.04.02 Exterior Lights

Hazard Warning Lights

The hazard warning light switch is located on the dash switch panel. See Fig. 45, [Truck Lower Dash Controls](#). The hazard lights can be activated regardless of the keyswitch position.

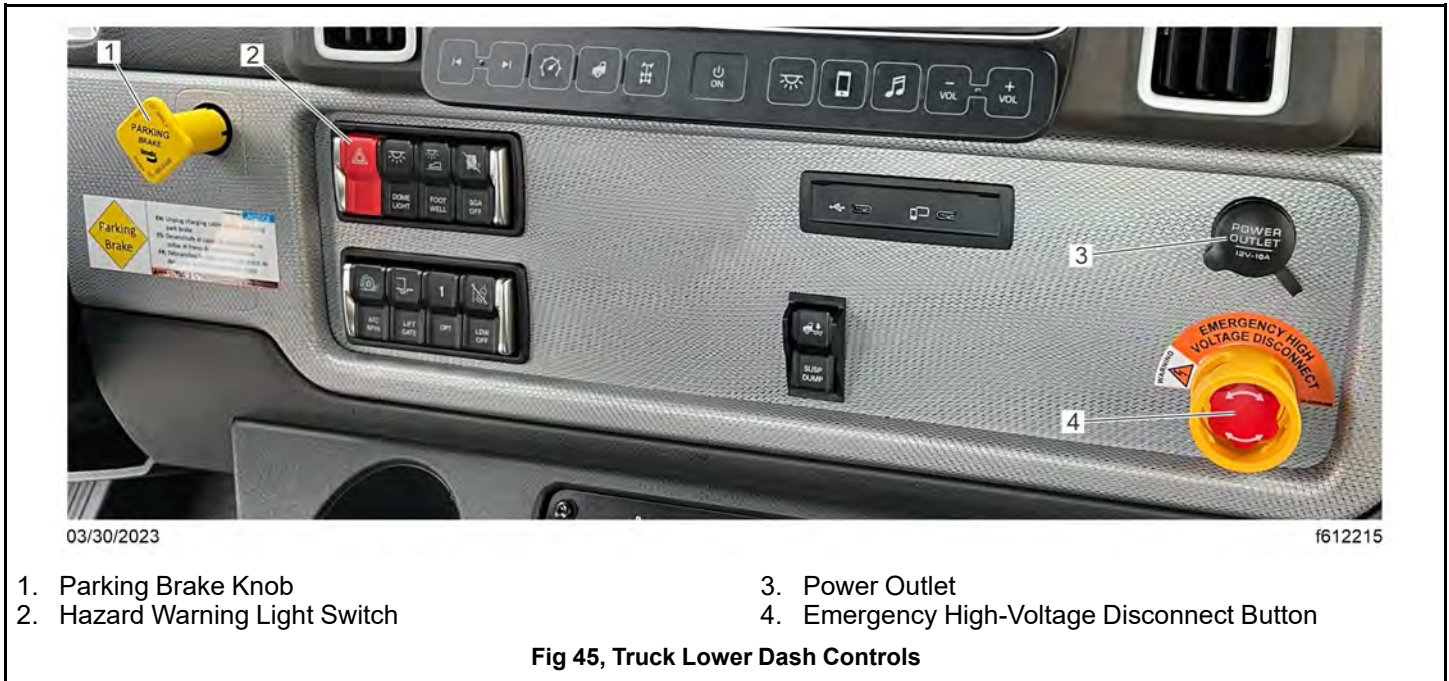

- 1. Parking Brake Knob
- 2. Hazard Warning Light Switch
- 3. Power Outlet
- 4. Emergency High-Voltage Disconnect Button

Fig 45, Truck Lower Dash Controls

To activate the hazard lights, press the center of the switch once.

All the turn signals on the vehicle and trailer, as well as the turn signal indicators in the ICU, flash simultaneously when the hazard lamps are activated. The switch blinks at the same rate that the hazard lamps flash.

Press the hazard warning light switch again to turn the lamps off.

Headlights

The headlight switch is a rotary switch located to the left of the steering column, above the ignition switch. See Fig. 46, [Headlight Switch](#).

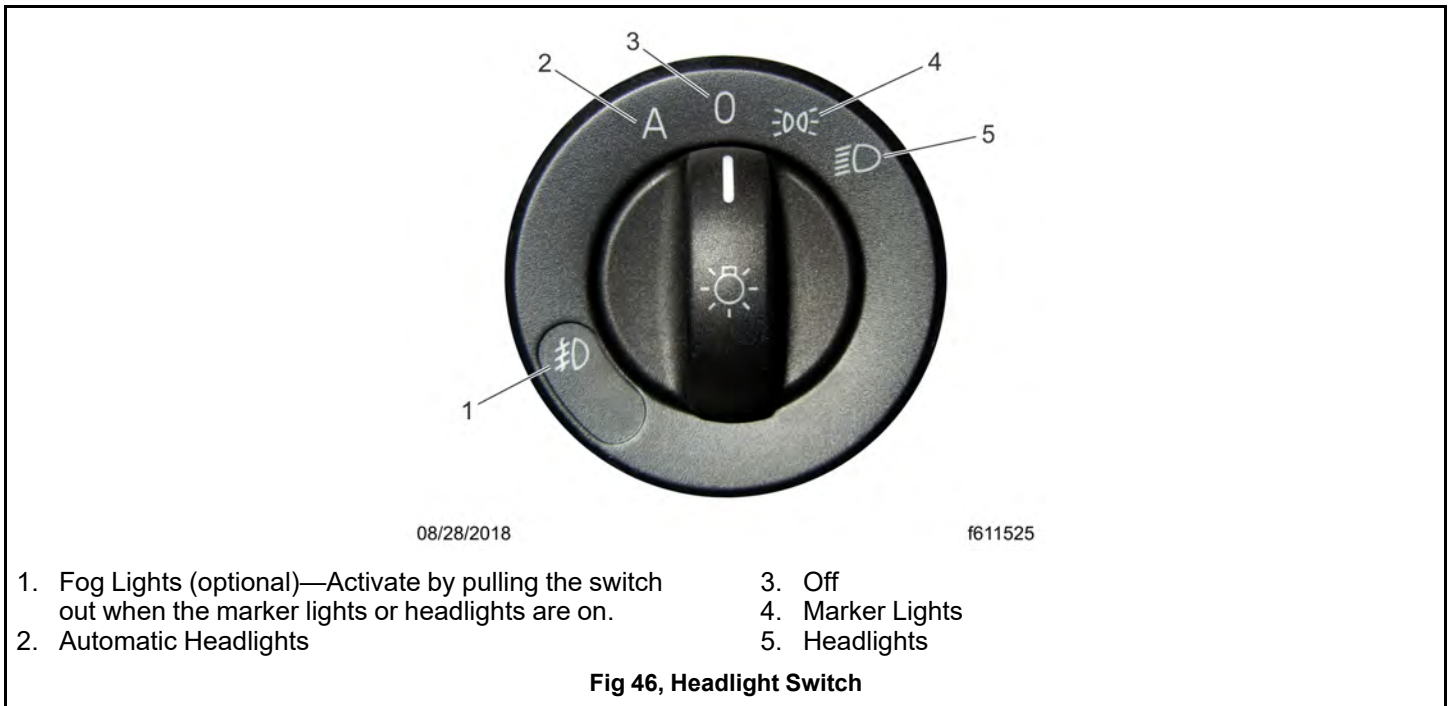

- 1. Fog Lights (optional)—Activate by pulling the switch out when the marker lights or headlights are on.
- 2. Automatic Headlights
- 3. Off
- 4. Marker Lights
- 5. Headlights

Fig 46, Headlight Switch

Automatic Headlights

The 'A' mark on the headlight switch indicates the automatic headlight function. When the headlight switch is turned to automatic headlights, all exterior lights and the low-beam headlights illuminate when the outside light decreases to a pre-set level. This level is measured by the rain-light sensor mounted at the top center of the windshield.

High-Beam Headlights

NOTE: The keyswitch must be ON for the high-beam headlights to work.

With the low-beam headlights on, push the turn-signal lever shown in See Fig. 47, [Steering Column-Mounted Turn Signal Lever](#) toward the hood to turn the high-beam headlights on. When the high-beam headlights are on, a blue telltale illuminates on the instrument cluster.

To switch to low-beam headlights, pull the lever to the middle position.

To momentarily flash the high-beam headlights while the low-beam headlights are on, pull the lever towards you.

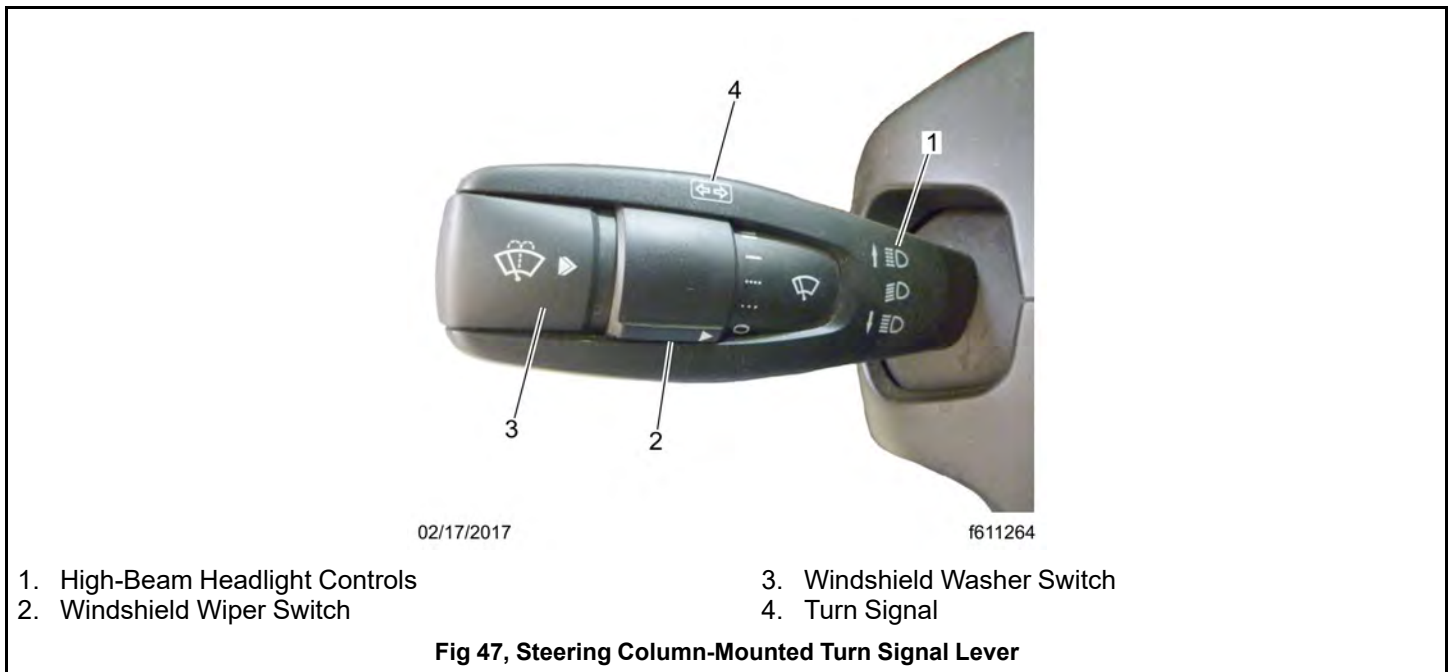

Intelligent High-Beam Headlights

The intelligent high-beam headlight feature activates when the headlight switch is in the 'A' position and the turn signal lever is pushed away from the driver in the high-beam position.

The high-beam headlights activate when there are no vehicles approaching from the opposite direction.

When a vehicle approaches from the opposite direction, the rain/light sensor registers their headlights and deactivates the high-beam headlights and activates the low-beam headlights.

Fog Lamps

Fog lamps are designed to reduce glare in foggy conditions. The marker lamps or headlights must be on in order to turn the LED fog lamps on. Pull the headlight switch out to activate them.

Marker Lamps

To turn the marker lamps on, turn the headlight switch clockwise past the off position. See Fig. 46, [Headlight Switch](#).

Marker Interrupt Switch

A marker interrupt switch is located in the left-hand switch pod of the steering wheel. See Fig. 48, [Steering-Wheel Pods](#). Pressing it temporarily flashes the marker lamps.

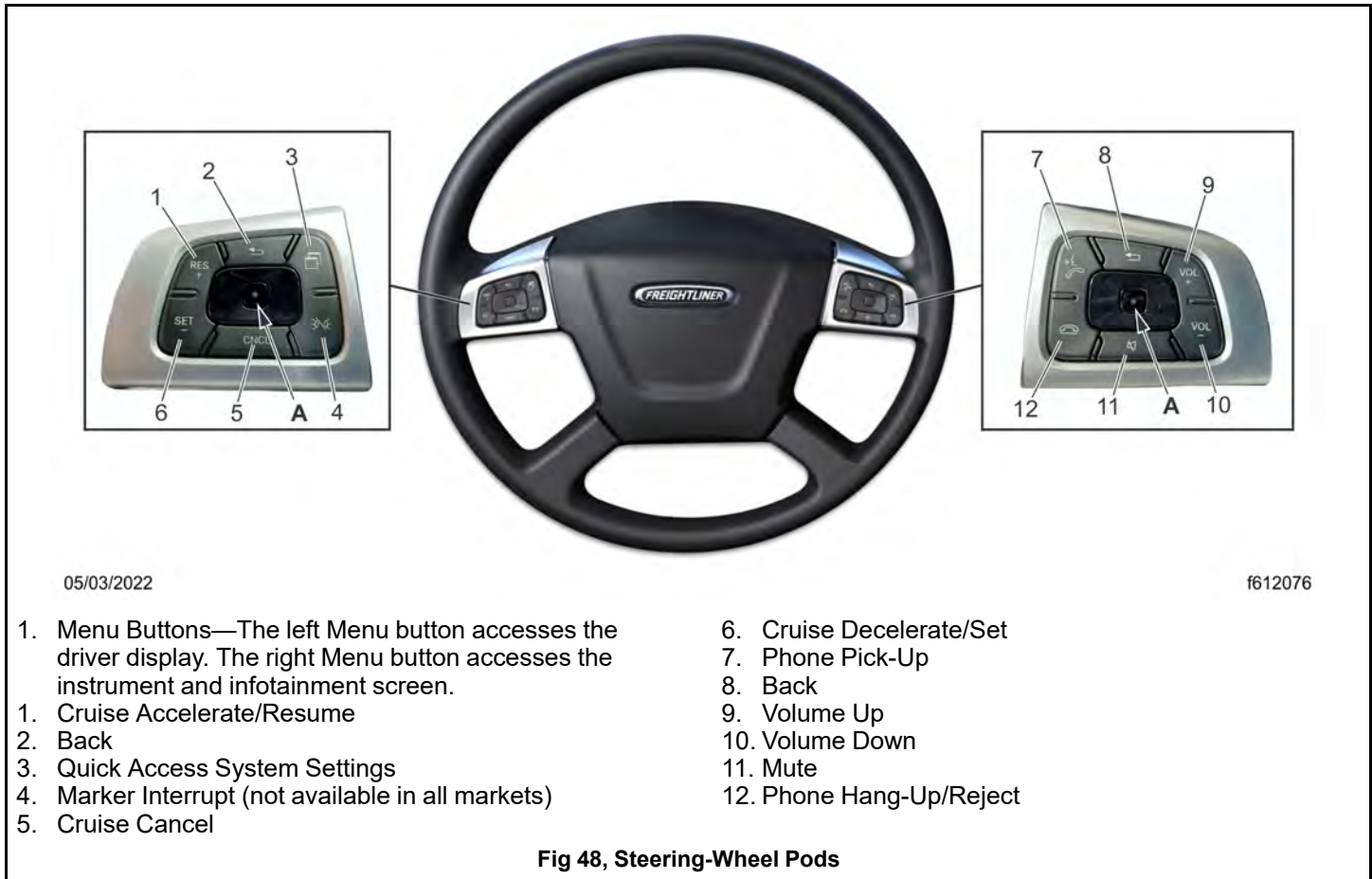

Daytime Running Lights

The vehicle is equipped with daytime running lights (DRL). These are automatically activated when the keyswitch is ON and the parking brake is released. The DRL turn off when the parking brake is applied or the headlights are turned on.

Daytime running lights are mandatory for vehicles domiciled in Canada. Vehicles domiciled in any other location may have an optional override switch as shown, see Fig. 49, [Daytime Running Lights Override Dash Switch](#). This is a momentary switch that enables the driver to deactivate the DRL.

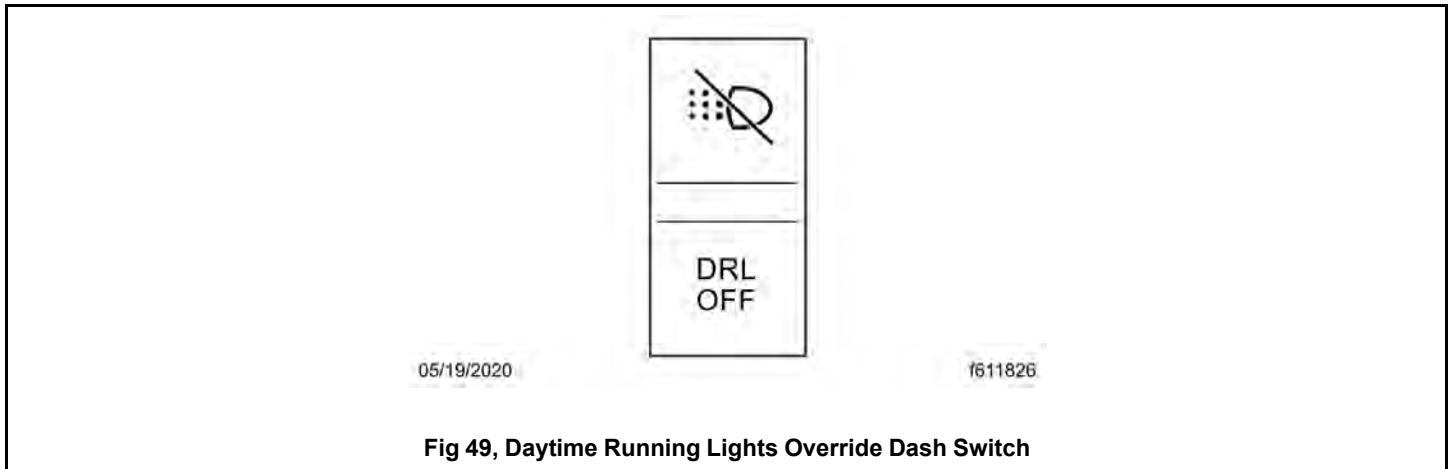

Turn Signals

The turn-signal lever is mounted on the left-hand side of the steering column. Pulling the turn-signal lever up activates the right-turn signal; pushing it down activates the left-turn signal.

When a turn signal is activated, the directionally equivalent turn signal telltale light flashes on the instrument panel.

The lever is self-canceling, meaning it automatically returns to the neutral position when the steering wheel returns to the straight-ahead position after a turn.

The lever is also a combination turn-signal, windshield wiper/washer switch, and high beam headlight control unit. See Fig. 47, [Steering Column-Mounted Turn Signal Lever](#).

Backup Lights

Backup lights activate only when the vehicle is in reverse, and are designed to be used when backing up in low light conditions.

Utility Lamps

Utility lamps can be flush-mounted on the back of the cab and swivel-mounted on the side extenders. Press the upper half of the switch, as shown, see Fig. 50, [Utility Light Dash Switch](#) to turn the utility lamps on or off.

When the utility lamps are on, a red indicator light in the utility light switch is illuminated.

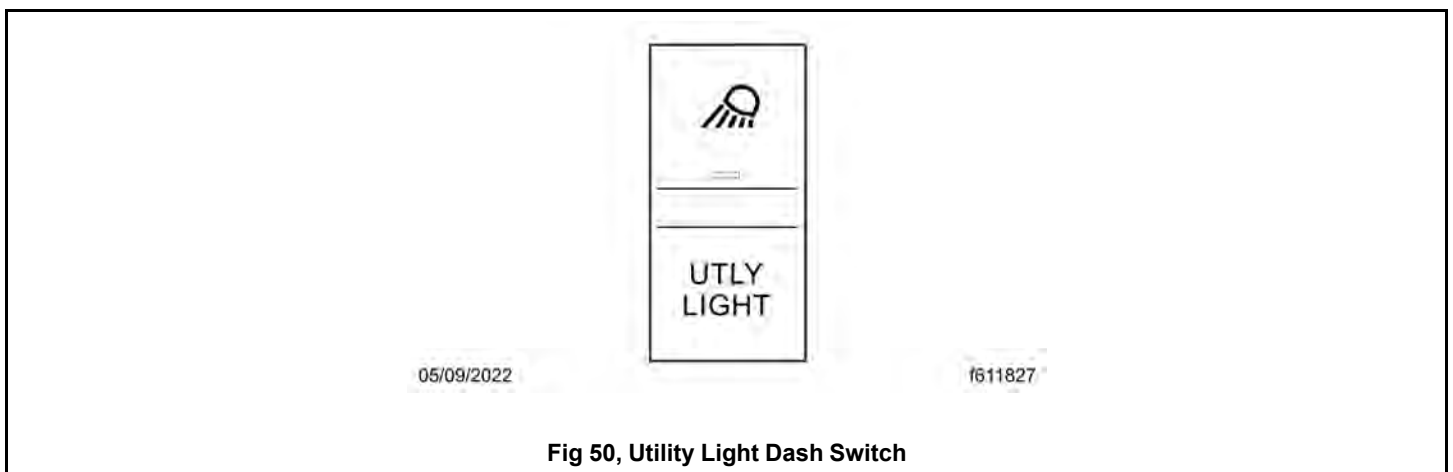

Pretrip Light Test

The pretrip light test allows the driver to walk around the vehicle to verify all exterior lights are working properly. A pretrip light test button is on the key fob, and there is a switch by the driver's door opening, near the base of the B-pillar grab handle. See Fig. 51, [Pretrip Light Test Switch Location](#).

Pressing either the button or the switch cause the exterior lights to flash on and off in sequence. Pressing again, stops the sequence.



1. B-Pillar Grab Handle

2. Pretrip Light Test Switch

Fig 51, Pretrip Light Test Switch Location

6.05 Other Dash Mounted Controls

6.05.01 Other Dash Mounted Controls

Parking Brake Control Valve

The yellow diamond-shaped knob operates the parking brake valve. See Fig. 52, [Truck Lower Dash Controls](#). Pull the knob out to apply the spring parking brakes. Push the parking brake knob in to release the spring parking brakes. Before the spring parking brakes can be released, the air pressure in the air brake system must be at least 65 psi (448 kPa).

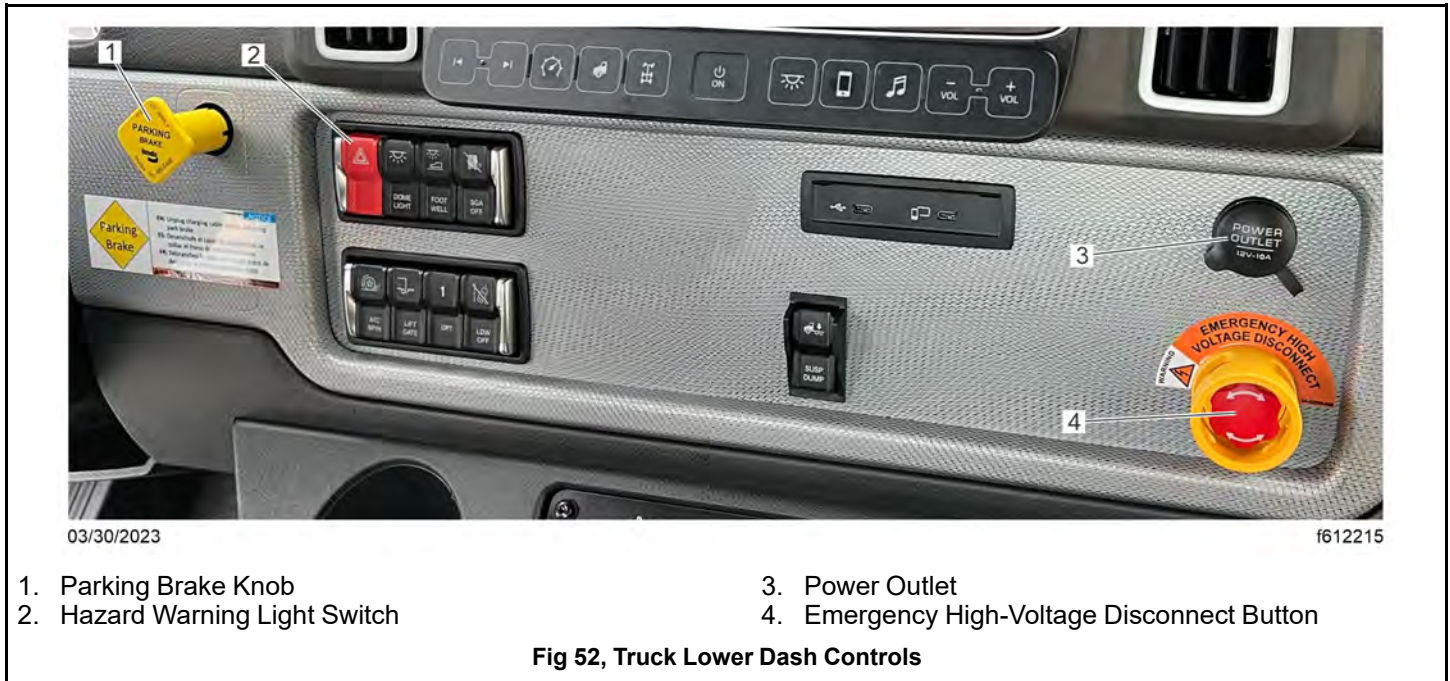

6.05.02 ATC Spin Switch

Vehicles with ABS+ have Automatic Traction Control (ATC). On these vehicles, the ATC system automatically limits wheel spin during reduced-traction situations.

Pressing the ATC SPIN switch as shown, see Fig. 53, [ATC SPIN Dash Switch](#) shuts ATC off and allows drive wheel spin. Pressing the switch again, or cycling the ignition key, cycles the system back to normal operation.



NOTICE:

The ATC spin feature is intended to be used under specific slippery conditions that require momentary increased wheel spin. Using this option for an extended period of time may damage the vehicle brake system.

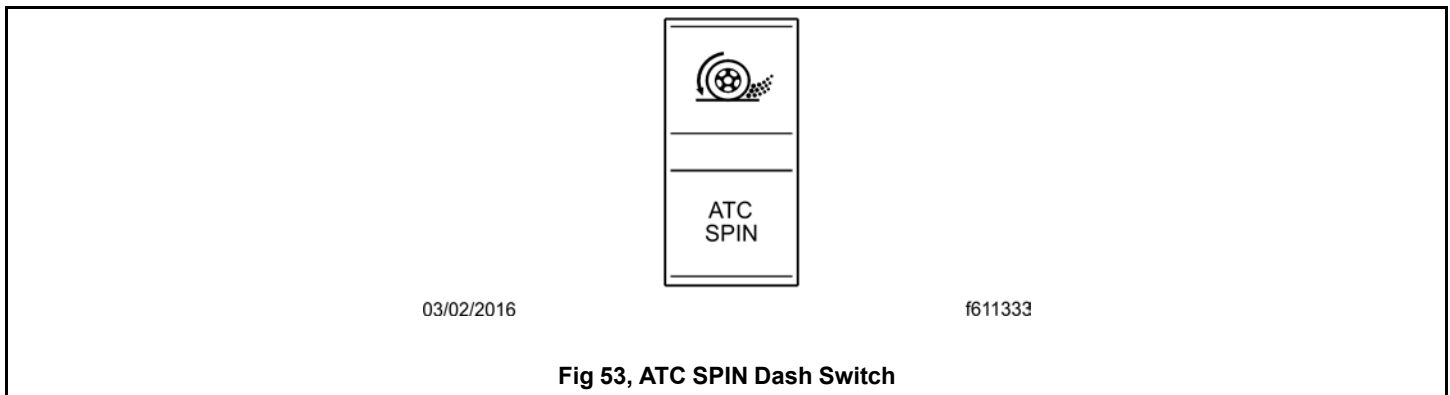

6.05.03 Hill Start Aid Override Switch

The Truck is equipped with a Hill Start Aid (HSA) feature to prevent the vehicle from rolling while on steep grades and to allow for a controlled launch. HSA delays the release of the service brakes until enough torque is available to begin moving the vehicle forward, for a maximum of 3 seconds. HSA is on by default. It can be turned off by pressing and releasing the HSA override switch on the dash. See Fig. 54, [Hill Start Aid Override Switch](#).



6.05.04 Air Suspension Height Control Switch



NOTICE:

Do not operate the vehicle over uneven ground such as ramps, speed bumps, curbs, etc. with the air springs deflated. Doing this may lead to air bag separation from the piston, preventing the suspension air springs from re-inflating.

Pressing the upper part of the switch, toward 'LOWER' deflates the air springs to lower the rear of the vehicle. A red LED in the switch is illuminated when the suspension is deflated. See Fig. 55, [Air Suspension Height Control Dash Switch](#).

Pressing the lower part of the switch, toward 'NORMAL,' causes the air springs inflate to raise the rear of the vehicle to normal ride height.

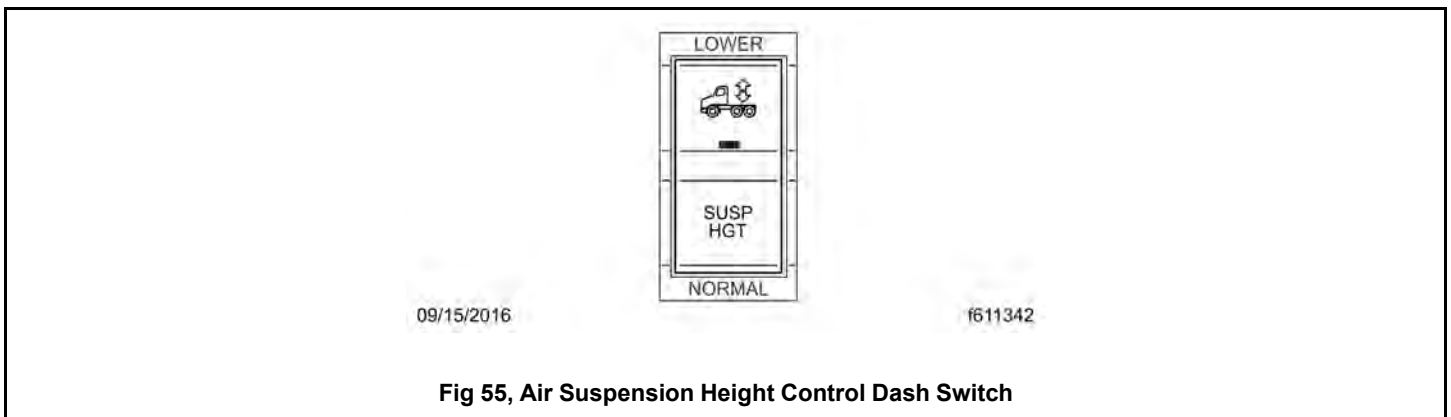

**NOTICE:**

Never exhaust air from the suspension while driving. When the air is exhausted, the suspension does not absorb road shocks, and components may be damaged.

6.06 Horn Control**6.06.01 Electric Horn**

The truck is equipped with an electric horn. The electric horn operates regardless of the position of the key. Activate the horn by pressing down on the center of the steering wheel pad. The horn sounds for the duration of the pad being pressed, up to 60 seconds.

7.01 Detroit Assurance Vehicle Camera	86
7.01.01 Multipurpose Camera 2 (MPC2).....	86
7.01.02 Rain/Light Sensor	86
7.02 Detroit Assurance Collision Mitigation System (CMS) Overview	86
7.02.01 General Information	86
7.02.02 Driver Display	87
7.03 Detroit Assurance Adaptive Cruise Control (ACC).....	87
7.03.01 Adaptive Cruise Control Safety Information.....	87
7.03.02 Adaptive Cruise Control Overview	88
7.04 Detroit Assurance Tailgate Warning	91
7.05 Detroit Assurance Active Brake Assist 5 (ABA5)	91
7.05.01 Active Brake Assist 5 Overview.....	91
7.05.02 Active Brake Assist 5 Safety Information.....	92
7.05.03 Activating/Deactivating Active Brake Assist 5	93
7.05.04 Active Brake Assist 5 Collision Warning and Emergency Braking.....	93
7.05.05 Overriding ABA Events.....	95
7.06 Limitations of Detroit Assurance ABA5 and ACC.....	95
7.07 Detroit Assurance Lane Departure Warning (LDW)	99
7.07.01 Safety Notes on Lane Departure Warning	99
7.07.02 Overview.....	99
7.07.03 Functions and Activation Conditions for Lane Departure Warning	99
7.07.04 Activating or Deactivating Lane Departure Warning (LDW).....	100
7.07.05 Cleaning the Windshield in the Area of the Camera	101
7.08 Detroit Assurance Side Guard Assist (SGA) and Active Side Guard Assist (ASGA)	101
7.08.01 General Information	101
7.08.02 Safety Information.....	102
7.08.03 Sensor Monitoring Range of SGA.....	103
7.08.04 SGA Telltales	104
7.08.05 Activating and Deactivating SGA Alerts	105
7.09 Detroit Assurance Telltales.....	106

7. Detroit Assurance

7.01 Detroit Assurance Vehicle Camera

7.01.01 Multipurpose Camera 2 (MPC2)

IMPORTANT: The windshield must be clean, unobstructed, and without damage for the proper operation of the multipurpose camera and rain/light sensor.

The multipurpose camera 2 unit for Detroit Assurance is mounted against the center of the windshield. The rain/light sensor is in the same housing. See Fig. 56, [MPC2 and Rain/Light Sensor Location](#).



The MPC2 works with the radar system to support multiple Detroit Assurance features. It is important for the driver to keep the windshield clean and unobstructed in order for the MPC2 to operate properly.

7.01.02 Rain/Light Sensor

This rain/light sensor (RLS) detects rain, snow, or other precipitation on the windshield and can determine the amount of ambient light.

If the windshield wipers are set to intermittent operation, they automatically start clearing the windshield when the RLS detects precipitation. For additional windshield wiper and headlight information, see [6.01 Steering Wheel Pods](#).

If the headlight switch is set to the automatic or 'A' position, the low beam headlights and vehicle exterior lights turn on when the RLS registers a low level of ambient light. This could happen due to sunset, fog, smoke, or any other event that decreases light levels.

7.02 Detroit Assurance Collision Mitigation System (CMS) Overview

7.02.01 General Information

The Detroit Assurance collision mitigation system (CMS) is a safety system that uses a radar mounted above the front bumper shown, see Fig.57, [Forward Radar Location](#) and a windshield-mounted multipurpose camera to communicate information to active features that can control the truck.

The system tracks vehicles up to 820 ft (250 m) ahead, and if necessary, sounds a warning and applies the brakes.



03/30/2023

f548201

1. Forward Radar

Fig 57, Forward Radar Location

IMPORTANT: Do not mount any attachments in front of the radar distance sensor. Do not paint or affix items over the distance sensor cover. Keep the cover free of mud, ice, and snow. Attachments mounted in front of the distance sensor, such as a crash guard, and objects on the sensor cover can impair the operation of the distance sensor.

7.02.02 Driver Display

The driver display presents the status and warnings from the different features that make up the Detroit Assurance safety system.

The standard core features of Detroit Assurance on the truck include active brake assist (ABA), adaptive cruise control (ACC), lane departure warning (LDW), active lane assist (ALA) with auto stop, tailgate warning, and side guard assist (SGA).

7.03 Detroit Assurance Adaptive Cruise Control (ACC)

7.03.01 Adaptive Cruise Control Safety Information



WARNING:

The Detroit Assurance collision mitigation system is intended solely as an aid for an alert and conscientious professional driver. It is not intended to be relied upon to operate a vehicle. Use the system in conjunction with rearview mirrors and other instruments to safely operate the vehicle.

The Detroit Assurance collision mitigation system is not a substitute for safe, normal driving procedures, nor compensates for any driver impairment such as drugs, alcohol, or fatigue.

Failure to drive safely and use the system properly could result in personal injury and/or death and severe property damage.

ACC may not detect vehicles driving in a different lane or narrow vehicles, like motorcycles, driving in front.

In particular, stay aware in the following situations:

- when cornering, entering, and exiting bends;
- when driving winding stretches of road;
- when overtaking;
- when there are vehicles driving in a different lane;
- when vehicles are changing lanes;
- when vehicles are exiting the road;
- when there are obstacles and stationary vehicles.

ACC does not compensate for inattentive driving, weather, or traffic conditions. ACC is only an aid. The driver is responsible for maintaining a safe distance from the vehicle in front, maintaining a safe vehicle speed, braking, and remaining in a lane.

If ACC does not detect a vehicle driving in front, the system accelerates to the set speed.

7.03.02 Adaptive Cruise Control Overview

For a description of cruise control steering wheel switches, see Fig. 58, [Steering-Wheel Cruise Control Switches](#) and see Table 17, [Steering Wheel Controls](#).



- 1. Resume/Increase Set Cruise Speed
- 2. Cancel Cruise Control
- 3. Set/Decrease Set Cruise Speed

Fig 58, Steering-Wheel Cruise Control Switches

Description	Function
Resumes the set speed. Pressing and holding increases the set cruise speed.	RES/+
Cancels cruise control, but retains the set speed in memory.	CNCL
Sets the cruise speed while the vehicle is traveling at the desired speed. Pressing and holding decreases the set cruise speed.	SET/-

Table 6, Steering Wheel Controls

When a vehicle is detected in front, the driver display shows a generic image of the detected vehicle, the detected vehicle's speed, and the distance to it. See Fig. 59, [Example of an Adaptive Cruise Control \(ACC\) Screen, ICC5](#).

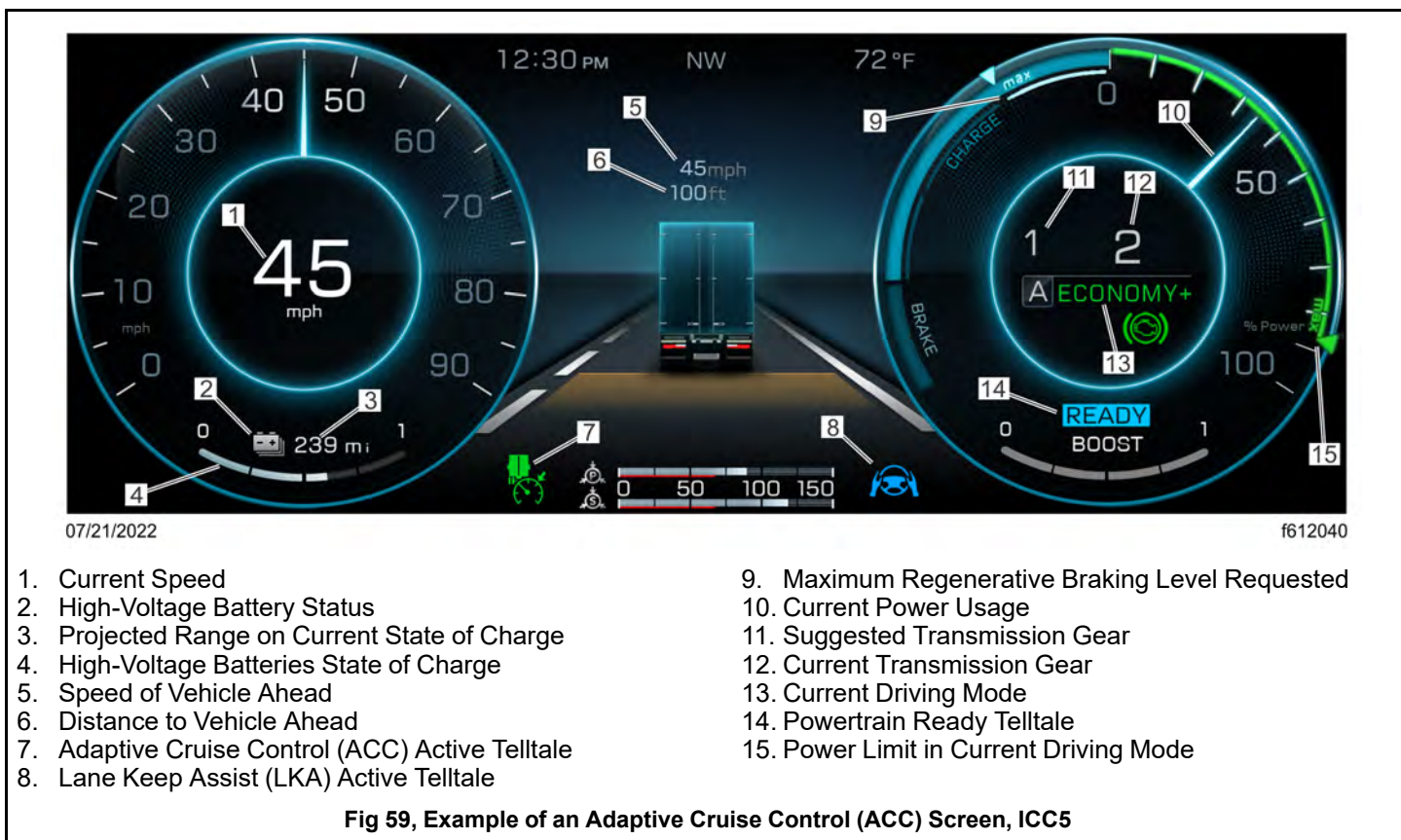

Adaptive Cruise Control Functions and Activation Conditions

ACC controls the speed of the equipped vehicle to maintain a safe distance from a vehicle detected in front.

If ACC detects a vehicle in front driving at a slower speed, the brakes are applied, slowing the vehicle to maintain the set following distance.

When a slower vehicle in front is no longer detected, ACC accelerates the equipped vehicle to the set speed.

ACC allows the vehicle to operate in cruise down to 0 mph (0 km/h); as traffic in front of the vehicle slows and eventually stops, the speed adjusts with the traffic until it is stationary.

If the vehicle ahead is stopped for two seconds or less, ACC resumes when the vehicle ahead moves. If the vehicle ahead is stopped for more than two seconds, the driver—after carefully checking surrounding traffic—must press the resume button or tap the accelerator pedal to move forward.

ACC also slows the vehicle if it exceeds the set speed (on a downhill grade, for example).

If there is no vehicle in front, ACC operates in the same way as standard cruise control when the vehicle is traveling above 10 mph (15 km/h).

IMPORTANT: IMPORTANT: Nothing should be put between the driver and the seat, such as a heating pad, massage pad, or similar items. Doing so may prevent the seat occupancy sensor from functioning correctly. ACC to 0 mph verifies seat occupancy before resuming forward motion after slowing down to 0 mph.

ACC cannot be activated, or is automatically deactivated, if:

- the driver is not in their seat to activate the seat occupancy sensor;

- reverse gear is selected;
- the anti-lock braking system (ABS) is deactivated;
- there is a malfunction in the brake system or the electronic management system; or
- the distance sensor initialization is not yet complete.

Activating Adaptive Cruise Control and Setting the Speed

Activate ACC by setting the cruise speed using the controls on the left-hand steering wheel switch pod.

When driving at the desired speed, press the **-/SET** switch to activate ACC and store the set speed.

If cruise control is deactivated, the stored speed can be activated again by pressing the **+/RES** switch.

When activated, the driver display shows the adaptive cruise control telltale shown, see Fig. 60, [Adaptive Cruise Control Active Telltale](#) and the set speed.



If the brake pedal is pressed, ACC is deactivated automatically.

If ACC becomes unavailable, a message appears on the driver display screen. If the vehicle is programmed to allow for standard cruise control, the message displayed allows the driver to use standard cruise control. See Fig. 61, [Adaptive Cruise Control \(ACC\) Unavailable, ICC5](#).

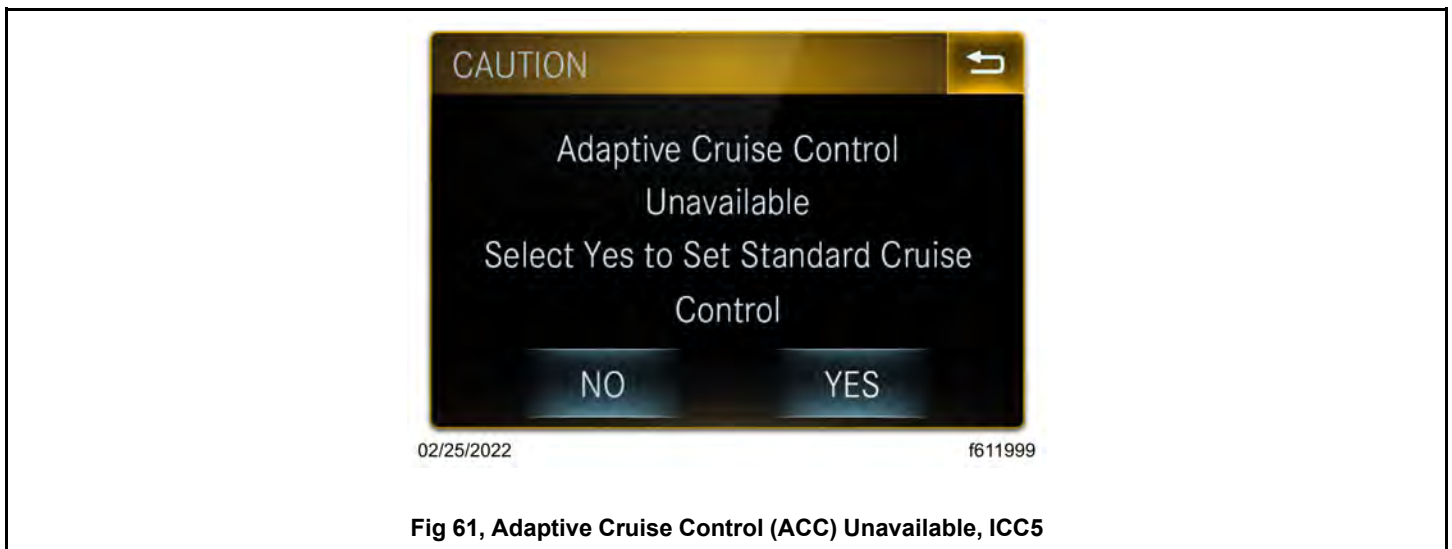

Increasing or Reducing the Adaptive Cruise Control Speed

The ACC speed setting can only be set when driving.

Press the **-/SET** switch on the steering wheel switch pod to set the cruise speed when the vehicle is traveling at the desired speed.

To decrease the set cruise speed, press or press and hold **–/SET**. A press decreases the ACC set speed by -1 units (mph or km/h). A press and hold decreases the ACC set speed by -5 units (mph or km/h).

Setting the Distance to the Vehicle in Front

If equipped, the following distance can be adjusted under 'Settings' > 'Driving Assistance' > 'Adaptive Cruise Control.'

IMPORTANT: Make sure that the minimum distance required by law is maintained.

Overtaking When Using Adaptive Cruise Control

NOTE: It is possible to exceed the set speed when overtaking.

The set speed of ACC can be exceeded using the accelerator pedal. When the accelerator pedal is released, the ACC set speed is resumed.

Deactivating Adaptive Cruise Control

To deactivate ACC, press the **CNCL** switch on the steering wheel switch pod or press the brake pedal.

NOTE: The set speed remains stored when ACC is deactivated.

7.04 Detroit Assurance Tailgate Warning

The tailgate warning provides alerts when the vehicle in front is being followed too closely.

The system gives warning when:

- ACC is not active;
- the vehicle is moving faster than 20 mph (32 km/h);
- the driver follows a vehicle for longer than 10 seconds at a distance that is traversed in less than 2.6 seconds.

The system also gives warnings when ACC is active, if:

- the driver is overriding the distance control by pressing on the accelerator pedal;
- the vehicle is moving faster than 20 mph (32 km/h);
- the driver follows a vehicle for longer than 10 seconds at a distance that is traversed in less than 2.6 seconds.

The system continues to give warnings every 20 seconds if the gap between the vehicles does not increase.

The system does **not** give warning when:

- the vehicle is moving slower than 20 mph (32 km/h);
- another vehicle cuts in front;
- the vehicle in front is moving away;
- ACC distance control is active.

7.05 Detroit Assurance Active Brake Assist 5 (ABA5)

7.05.01 Active Brake Assist 5 Overview

IMPORTANT: The windshield must be clean, unobstructed, and without damage for proper operation of the multipurpose camera. No objects or attachments should be mounted in front of the forward radar and the radar covering should be free of paint, stickers, mud, ice, or snow.

ABA5 is active when the vehicle is on.

ABA5 uses fused camera and radar signals for improved object recognition, enabling it, in some cases, to recognize potential hazardous situations faster than a driver. If the camera cannot positively identify an object, radar signals alone are used. If the camera becomes unplugged or otherwise disabled, ABA5 is disabled.

ABA5 tracks both moving and stationary objects in the vehicle's path and, if necessary, engages in a cascade of defensive actions in reaction to those objects through:

1. visual and auditory warnings;
2. then partial braking;
3. then full or emergency braking.

In addition to moving and braking vehicles, ABA5 has the capacity to recognize and engage in emergency braking for moving pedestrians, parked vehicles, and stopped traffic.

However, the system may not detect pedestrians or objects in every situation. ABA5 is not a substitute for cautious driving.

7.05.02 Active Brake Assist 5 Safety Information



WARNING:

Active Brake Assist (ABA5) is intended only as an aid for a conscientious and alert driver. The driver is responsible for keeping a safe distance from the vehicle in front, for the vehicle speed, braking in a sufficient amount of time, and remaining in the lane.

ABA5 does not take road and weather conditions into account, nor the prevailing traffic situation. The driver should always adapt their driving to suit road and weather conditions.

The Detroit Assurance Collision Mitigation System is not designed to warn about all possible road hazards. Specifically, it is not programmed to react to animals, oncoming vehicles, or cross traffic, but it may do so.

Operate a vehicle equipped with Detroit Assurance Collision Mitigation System as if the vehicle were not equipped with a collision mitigation system.

Failure to drive safely and use the system properly could result in personal injury and/or death and severe property damage.

A vehicle equipped with ABA5 may:

- react more quickly than a driver to an object in the vehicle's path of travel;
- perform emergency braking;
- react to moving people with a warning and emergency braking.

ABA5 can minimize the risk of a front-end collision with a moving or stationary vehicle and pedestrians. If ABA5 detects the risk of a front-end collision, it issues an audible and visual warning. If the risk persists, ABA5 automatically initiates partial braking of the vehicle. If the driver does not react to the warnings and partial brake application, ABA5 automatically initiates a full emergency brake application.

ABA5 is not designed to detect and react to vehicles driving in a different lane.

ABA5 may not react to narrow vehicles, like motorcycles, driving in front of the vehicle.

A driver should always be aware of possible hazards and be prepared to engage the service brakes if the ABA5 system warns of a possible pending collision.

ABA5 does not automatically adapt to road and traffic conditions. If ABA5 issues no visual and/or acoustic warning in a critical situation:

- it is suppressed;
- it has failed;
- it has not recognized the danger of the situation.

ABA may also issue warnings where no risk exists. An alert and conscientious driver should be able to easily validate an ABA warning, and, if necessary, override a false-positive ABA5 braking event.

7.05.03 Activating/Deactivating Active Brake Assist 5

The only way to turn the ABA5 system off is to turn the vehicle off.

To override an active warning and braking event sequence, press the accelerator pedal past the pressure point to engage kickdown.

If there is a system error, the ABA5 unavailable telltale, as shown in Fig. 62, [ABA5 Unavailable Telltale](#), illuminates on the driver display screen and a caution window, as shown in Fig. 63, [ABA5 Unavailable Alert, ICC5](#), is shown on the driver display.

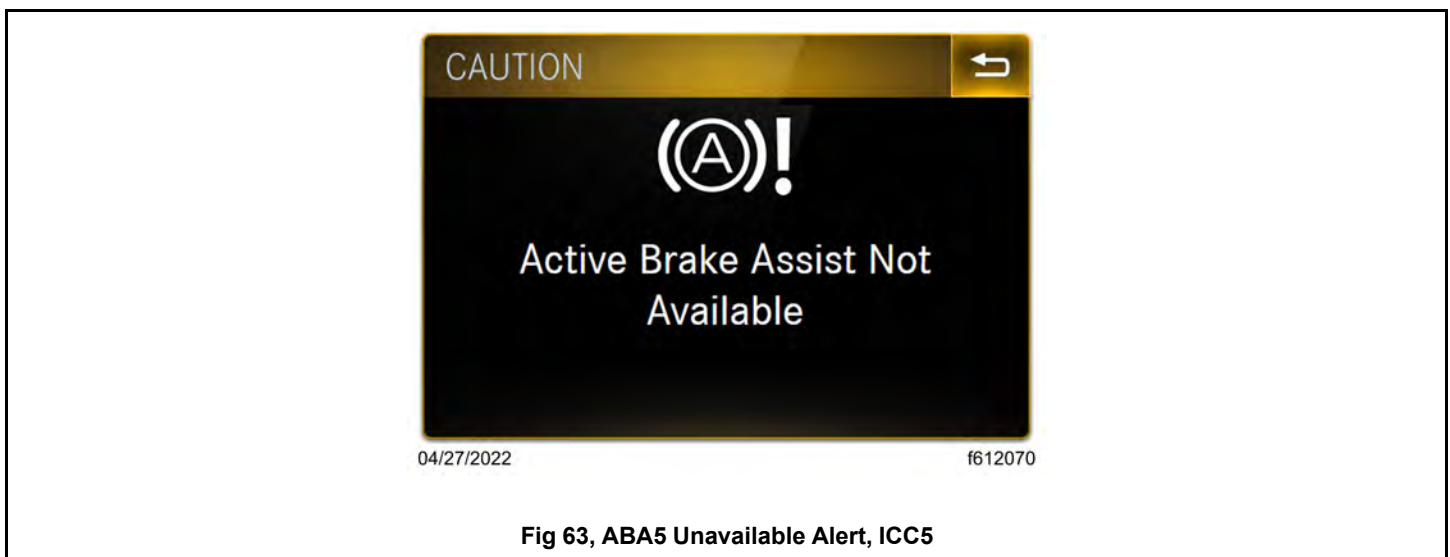

7.05.04 Active Brake Assist 5 Collision Warning and Emergency Braking

NOTE: To override an active warning and braking event sequence, press the accelerator pedal past the pressure point to engage kickdown.

If there is a collision risk, ABA5 engages in the following cascade of warnings:

1. **Issues Warnings:** the radio and/or hands free system is muted, the vehicle issues a warning beeping, and an ABA5 collision warning window, shown in See Fig. 64, [First Visual ABA5 Warning, ICC5](#), appears on the driver display.

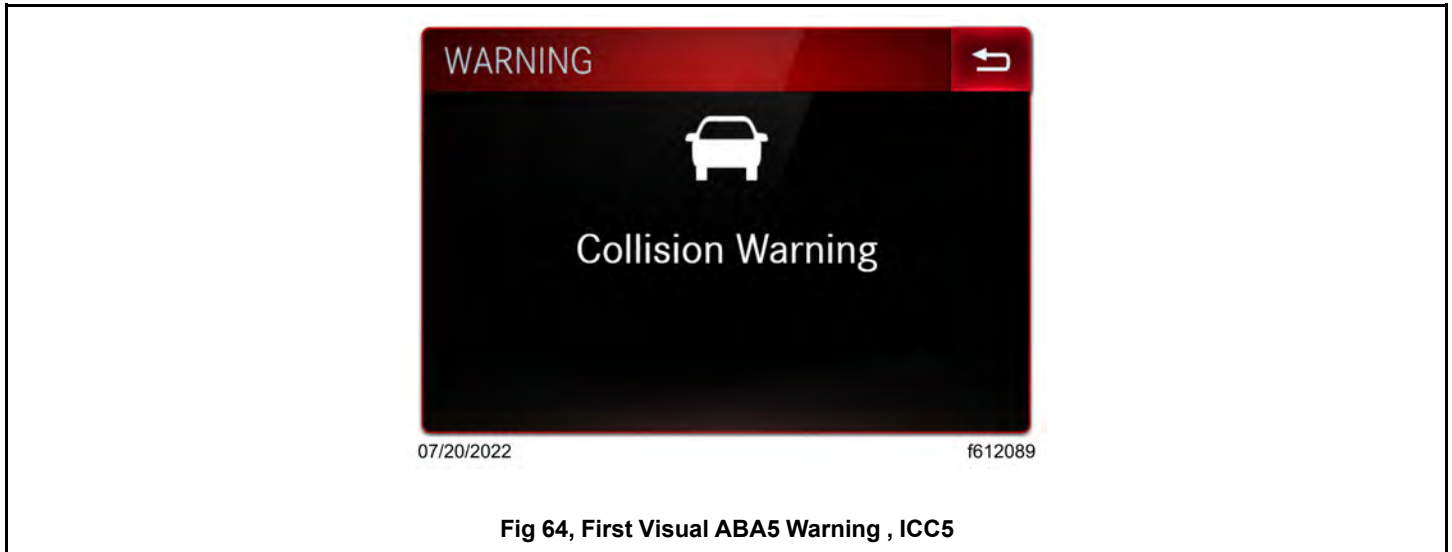

- Engages in Partial Braking:** ABA5 brakes the vehicle with around 50 percent of the vehicle's maximum braking power. The radio and/or hands free system stays muted, the warning beeping continues, and the ABA5 collision warning, shown in See Fig. 64, [First Visual ABA5 Warning , ICC5](#) , continues to appear or, if previously dismissed, reappears on the driver display.
- Engages in Emergency Braking:** If a driver does not react to the collision warnings or partial brake application, ABA5 brakes the vehicle with 100 percent of the vehicle's maximum braking power. The radio and/or hands free system stays muted, the warning beeping shifts to a continuous tone, and the emergency braking warning, as shown in Fig. 65, [Second Visual ABA5 Warning , ICC5](#).ppears on the driver display.

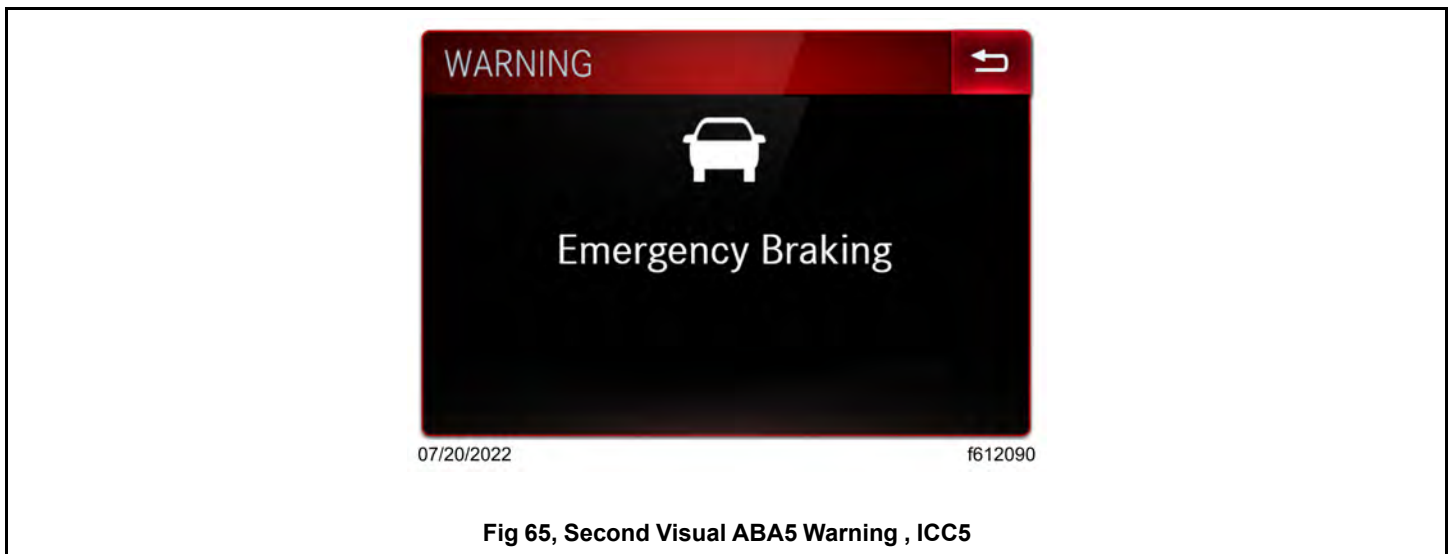

- Brakes Release:** The radio and/or hands free system is taken off mute, the warning tone ceases, and the notice as shown in Fig. 66, [Third Visual ABA5 Warning, ICC5](#) appears on the driver display.

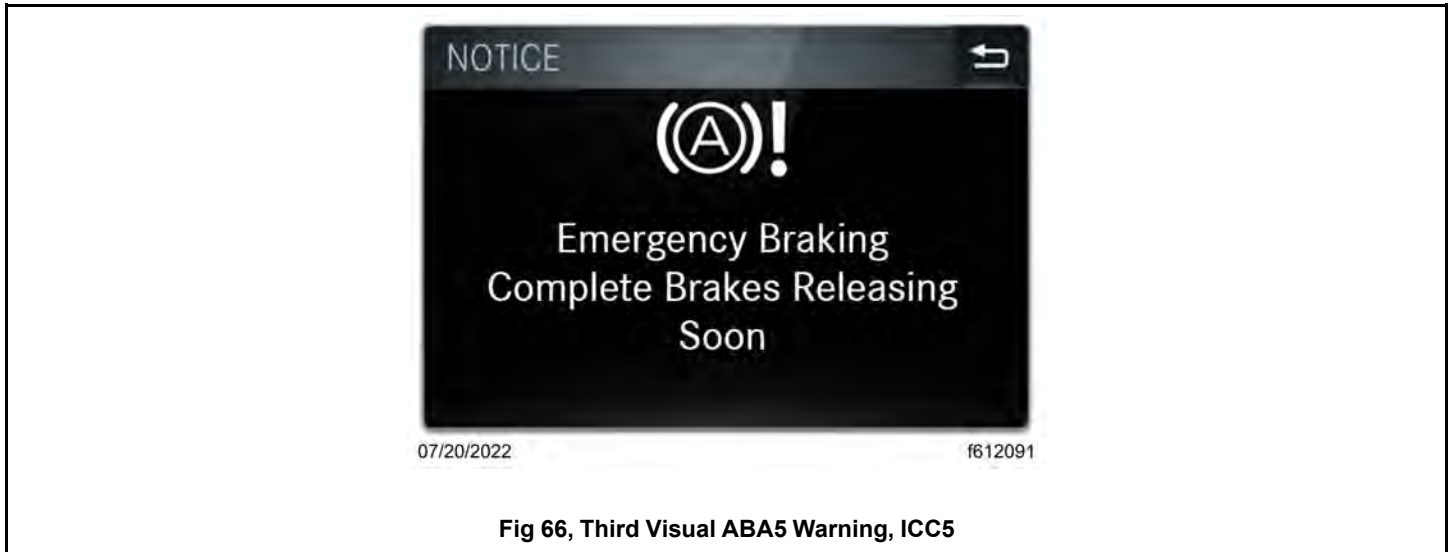

Fig 66, Third Visual ABA5 Warning, ICC5

After retaking control, the driver should take the first opportunity to safely move the vehicle from traffic. Before continuing, the driver should confirm that the vehicle is in good operating condition and that the load is still properly secured.



CAUTION:

After an emergency braking maneuver has been performed, if necessary, move the vehicle from the area of danger. Take the first opportunity to safely move the vehicle away from traffic and confirm the load is still properly secured and that the vehicle is still in good operating order. Failure to do so may result in personal injury and product or property damage. Always apply the parking brake prior to exiting the vehicle.

7.05.05 Overriding ABA Events

If ABA sets off an audio and/or haptic warning where the driver determines that no risk exists or the critical situation has resolved, an alert and conscientious driver may override the ABA braking event.

To override the ABA alert, fully depress the throttle to the floor. If you are already at full throttle, release the throttle and fully depress again to cancel the warning cascade.

7.06 Limitations of Detroit Assurance ABA5 and ACC

See Table 18, [Adaptive Cruise Control and Active Brake Assist 5 Limitations](#) for a description of ABA5 and ACC limitations in specific driving conditions.



Condition and Illustration	Description
<p>Cornering, entering and exiting bends</p>  <p>07/27/2022 f040877</p>	<p>The ability of ABA5 and ACC to react to vehicles on bends is limited. ABA5 and ACC may react to a vehicle or object in an adjoining lane and unexpectedly issue warnings or brake the vehicle. ABA5 and ACC may be slow to react to a vehicle or object previously hidden by a bend in the lane. ACC may also accelerate the vehicle unexpectedly if the vehicle ahead is hidden by a bend in the lane.</p>
<p>Vehicles not traveling in line with your vehicle and stationary vehicles</p>  <p>07/27/2022 f040883</p>	<p>The ability of ABA5 and ACC to react to vehicles not traveling in line with your vehicle and stationary vehicles is limited. ABA5 and ACC may react to a vehicle or object partially in your lane and unexpectedly issue warnings or brake your vehicle. ABA5 and ACC may be slow or fail to react to vehicles not traveling in line with your vehicle or stationary vehicles only partially in your lane. ACC may not detect and react to vehicles not traveling in line with your vehicle or stationary vehicles partially in your lane and may accelerate unexpectedly.</p>
<p>Other vehicles changing lanes</p>  <p>07/27/2022 f040884</p>	<p>The ability of ABA5 and ACC to detect and react to vehicles pulling into your lane without maintaining a safe distance is limited. ABA5 and ACC may be slow to react or fail to react to a vehicle entering your lane if the distance to the vehicle entering the lane is too short. ACC may accelerate unexpectedly if it fails to detect the vehicle entering the lane. If a vehicle cuts in front, brake your vehicle to increase the following distance.</p>
<p>Narrow vehicles changing lanes</p>	<p>The ability of ABA5 and ACC to detect and react to narrow vehicles pulling into your lane is limited. Narrow vehicles may be slow to enter the system's detection range. ABA5 and ACC may be slow to react or fail to react to a critical driving situation due to the merging vehicle being slow to enter the system's detection range. ACC may accelerate unexpectedly if it fails to detect the vehicle entering the lane.</p>

Table 18, Adaptive Cruise Control and Active Brake Assist 5 Limitations



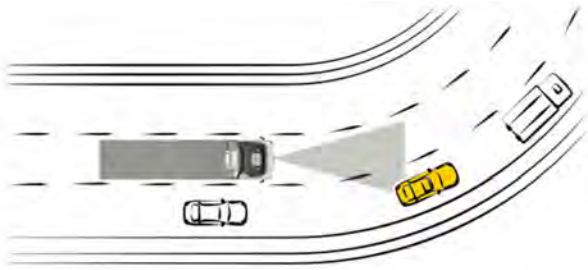
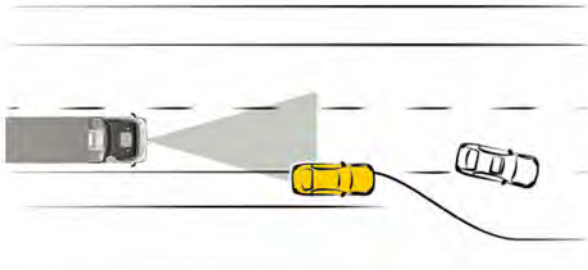

Condition and Illustration	Description
 <p>07/27/2022 f040876</p>	
<p>Vehicles turning off or in a nonstandard orientation</p>  <p>07/27/2022 f040885</p>	<p>The ability of ABA5 and ACC to detect and react to vehicles turning off or vehicles in a nonstandard orientation is limited.</p> <p>ABA5 and ACC may react to a vehicle turning off and unexpectedly issue warnings or brake the vehicle.</p> <p>ABA5 and ACC may be slow or fail to react to a vehicle turning off or to a vehicle at an angle due to an accident even through there is a critical driving situation.</p>
<p>Overtaking</p>  <p>07/27/2022 f040879</p>	<p>The ability of ABA5 and ACC to detect and react to a vehicle you are overtaking is limited.</p> <p>When overtaking a vehicle, ABA5 and ACC may unexpectedly issue warnings or brake your vehicle if you drive too close to the vehicle you are overtaking before exiting that lane.</p>
<p>Winding stretches of road</p>  <p>07/27/2022 f040886</p>	<p>On winding stretches of road, ABA5 and ACC cannot detect which lane the vehicle in front is driving in.</p> <p>ABA5 and ACC may unexpectedly issue warnings or brake your vehicle when reacting to vehicles in a different lane.</p> <p>ABA5 and ACC may be slow to react or fail to react to a vehicle in your lane even through there is a critical driving situation.</p> <p>ACC may fail to detect the vehicle in front in your lane and may accelerate the vehicle unexpectedly.</p>

Table 18, Adaptive Cruise Control and Active Brake Assist 5 Limitations

Condition and Illustration	Description
<p>Obstacles and stationary vehicles in front of a detected vehicle</p>  <p>07/27/2022 f040878</p>	<p>The ability of ABA5 and ACC to detect and react to objects when the detected vehicle turns off is limited.</p> <p>When the detected vehicle turns off, ABA5 and ACC may react to the obstacle or stationary vehicle that was in front of the detected vehicle and unexpectedly issue warnings or brake your vehicle.</p> <p>When the detected vehicle turns off, ABA5 and ACC may be slow to react or fail to react to an obstacle or stationary vehicle that was in front of the detected vehicle even though there is a critical driving situation.</p> <p>ACC may react to the vehicle turning off by accelerating unexpectedly.</p>
<p>Vehicles parked or broken down at the side of the road</p>  <p>07/27/2022 f040880</p>	<p>The ability of ABA5 and ACC to detect and react to a stationary vehicle on the side of the road is limited.</p> <p>ABA5 and ACC may unexpectedly issue warnings or brake your vehicle if it detects a vehicle on the side of the road.</p>
<p>Stationary objects</p>  <p>07/27/2022 f040882</p>	<p>The ability of ABA5 and ACC to detect and react to stationary objects above, beside, and on the road is limited.</p> <p>ABA5 and ACC can unexpectedly issue warnings and brake the vehicle if it detects stationary objects beside, above, or in front of your lane such as:</p> <ul style="list-style-type: none"> • signs • traffic islands • some bridges, such as truss and cable bridges • low overpasses
<p>People</p>  <p>07/27/2022 f040881</p>	<p>The ability of ABA5 to detect and react to people in certain situations is limited.</p> <p>ABA5 can unexpectedly issue warnings and brake the vehicle if it detects and reacts to:</p> <ul style="list-style-type: none"> • people on the roadside on a curve • people walking beside the road • people in a tunnel

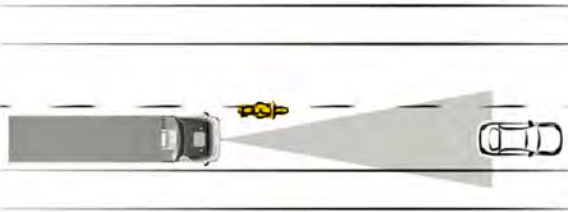
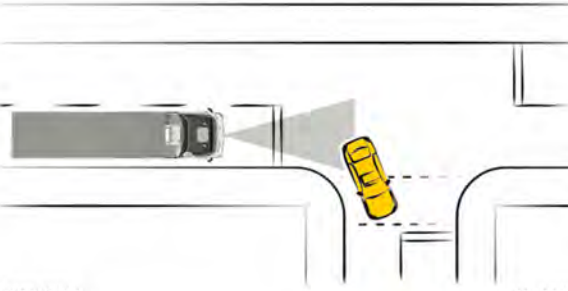
7.07 Detroit Assurance Lane Departure Warning (LDW)

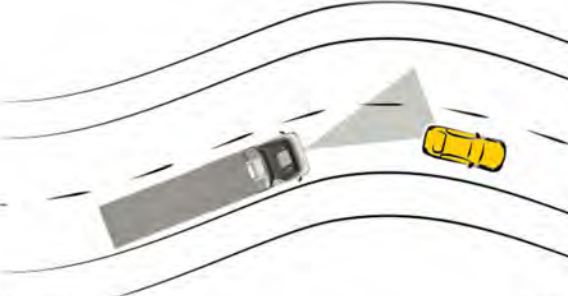
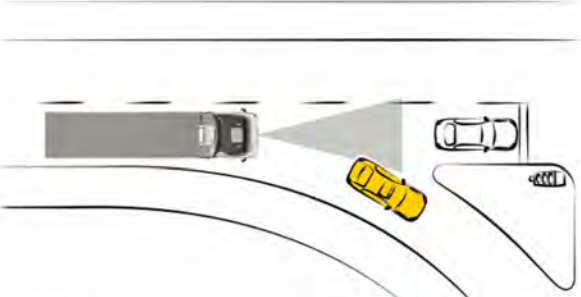
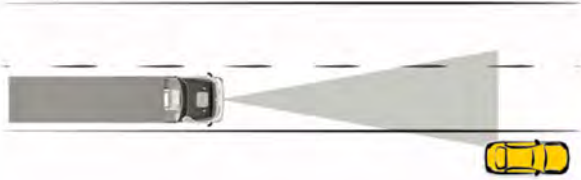
7.07.01 Safety Notes on Lane Departure Warning

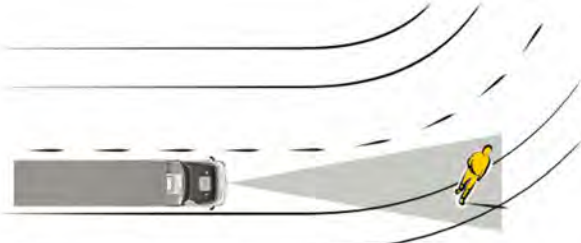

WARNING:

The LDW system is intended only as an aid for a conscientious and alert driver. Do not rely solely on the system to safely operate the vehicle.

The system may not indicate lane departures under certain conditions. Read the information in this manual to understand the circumstances under which this system may not provide adequate lane departure warnings.

The system does not provide warnings for all possible hazards. LDW is not a substitute for safe driving procedures and cannot prevent an accident if the driver is impaired or not driving safely.

Failure to use the system properly could result in personal injury and/or death and severe property damage.

The system may be impaired or may not operate in the following situations:

- There is low visibility due to insufficient road illumination, or due to snow, rain, fog, heavy spray, smoke, or other circumstances that limit visibility.
- There is glare due to oncoming traffic, direct sunlight, or reflections from wet road surfaces.
- The windshield in the area of the camera is dirty, misted up, damaged, or covered by a sticker.
- No lane markings or several varied lane markings are present, such as in a construction zone.
- The lane markings are worn, dark, or covered—such as by sand, dirt, or snow.
- The distance from the vehicle in front is too small and prevents the lane markings from being detected.
- The lane markings change rapidly, such as when lanes merge, branch off, or cross.
- Lanes are very narrow or winding.
- Shade conditions on the road surface vary widely.

The driver must adapt their driving style to current conditions. LDW cannot take the road and weather conditions into account, nor the prevailing traffic situation. The driver is responsible for the distance to the vehicle in front, for vehicle speed, braking in good time, and remaining in the lane.

7.07.02 Overview

LDW monitors the area in front of the vehicle using the multipurpose camera mounted at the top of the windshield. When LDW is active and detecting lane markings, it visually and audibly warns the driver if it thinks the vehicle may be leaving the lane unintentionally.

LDW only needs one identifiable lane line to function.

7.07.03 Functions and Activation Conditions for Lane Departure Warning

The Detroit Assurance LDW system is designed to warn the driver as the vehicle crosses the outer boundary of the lane marking. This may differ from other LDW systems which issue a warning as the driver approaches the inside of the lane marking. If the system warns at, or just beyond the outer edge of the lane marking, the system is performing as designed. If the warning does not occur, or occurs after an excessive lane departure, the system may not be operating properly.

Lane departure warning only issues warnings if the speed is above approximately 37 mph (60 km/h).

The lane markings on the driver display screen show the status and state of LDW:

- No lane markings indicate that LDW is off.
- Outlined lane markings indicate that LDW is not ready.
- Solid white markings indicate LDW is on and ready to issue warnings.

- Red lane markings indicate a lane departure is occurring; red lane markings are a visual warning from the LDW system.

In addition to the visual warning, when driving over lane markings unintentionally, the volume of audio equipment like the radio and/or hands-free systems is muted and a "rumble-strip noise" emits from the side of the vehicle driving over the lane markings.

LDW does not issue an audible warning when:

- the turn signals are switched on
- if the driver is braking or accelerating
- if the driver is making a sharp turn
- if a driving safety system such as ABA, stability control, or ACC intervenes.

7.07.04 Activating or Deactivating Lane Departure Warning (LDW)

When the vehicle is turned on, LDW is automatically activated.

NOTE: There is no audible self-test of the "rumble-strip noise" of LDW when the vehicle is switched on.

Pressing the LDW OFF switch deactivates LDW for fifteen minutes. This may be used when driving on winding roads or through construction zones or other areas where lane markings are not clear. The LDW OFF switch may be a physical dash switch shown in Fig. 67, [Lane Departure Warning Off Physical Switch](#) and/or a digital switch in the ICC5 infotainment panel under 'Digital Switches' shown in Fig. 68, [Lane Departure Warning Off Digital Switch, ICC5](#) in When LDW is deactivated, the switch indicator illuminates.

A driver might want to turn off LDW on winding roads or when driving through construction zones or other areas where lane markings are not clear.

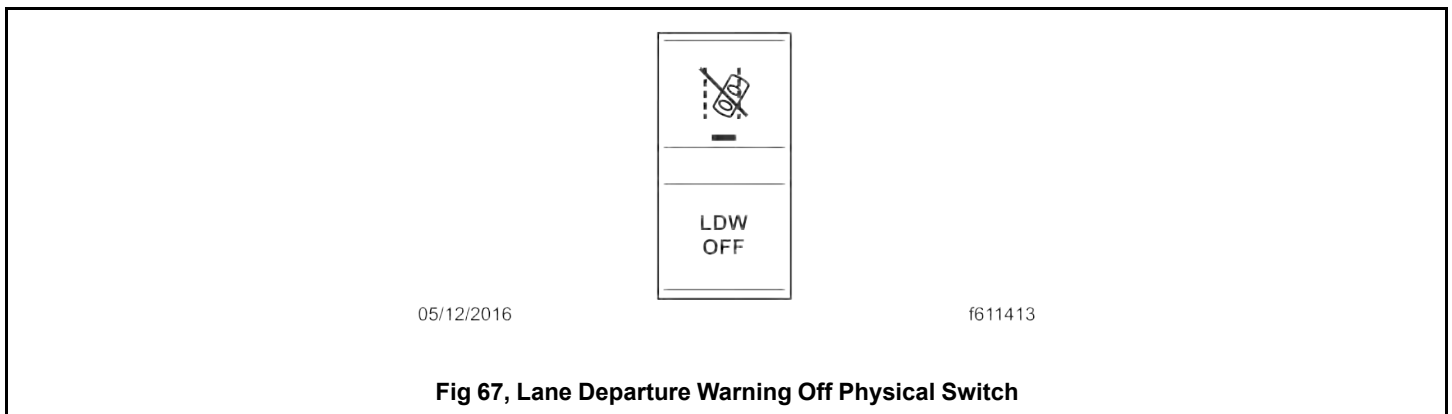

LDW is not active if:

- the driver presses the LDW OFF switch;
- the system is searching for a lane.

If there is a system error, the LDW unavailable telltale, as shown in Fig.69, [LDW Unavailable Telltale, ICC5](#), illuminates on the driver display.



7.07.05 Cleaning the Windshield in the Area of the Camera

Make sure that the windshield is always kept clean and unobstructed in the area of the camera.

During rainy or cold weather, the driver should switch on the windshield wiper to clear the windshield and remove snow and ice to avoid incorrect lane detection.

If the area of the windshield is damaged, LDW may not work as intended. If this happens, the windshield must be replaced.

7.08 Detroit Assurance Side Guard Assist (SGA) and Active Side Guard Assist (ASGA)

7.08.01 General Information

SGA provides assistance on the passenger-side of the vehicle while turning and changing lanes. SGA monitors the area on the passenger-side of the vehicle using two short range radar sensors. The radar sensors are mounted close to the rear of the passenger footsteps. See Fig. 70, [Side Guard Assist Radar](#). The optional enhancement, ASGA, enables the brakes to automatically activate in certain low-speed passenger-side turns.

A triangular warning lamp in the A-pillar is located near the side mirror. This lamp, as shown in Fig. 71, [Passenger Side A Pillar](#), lights up to inform the driver that an object is detected in the monitored area. An additional warning tone sounds if there is a risk of collision.

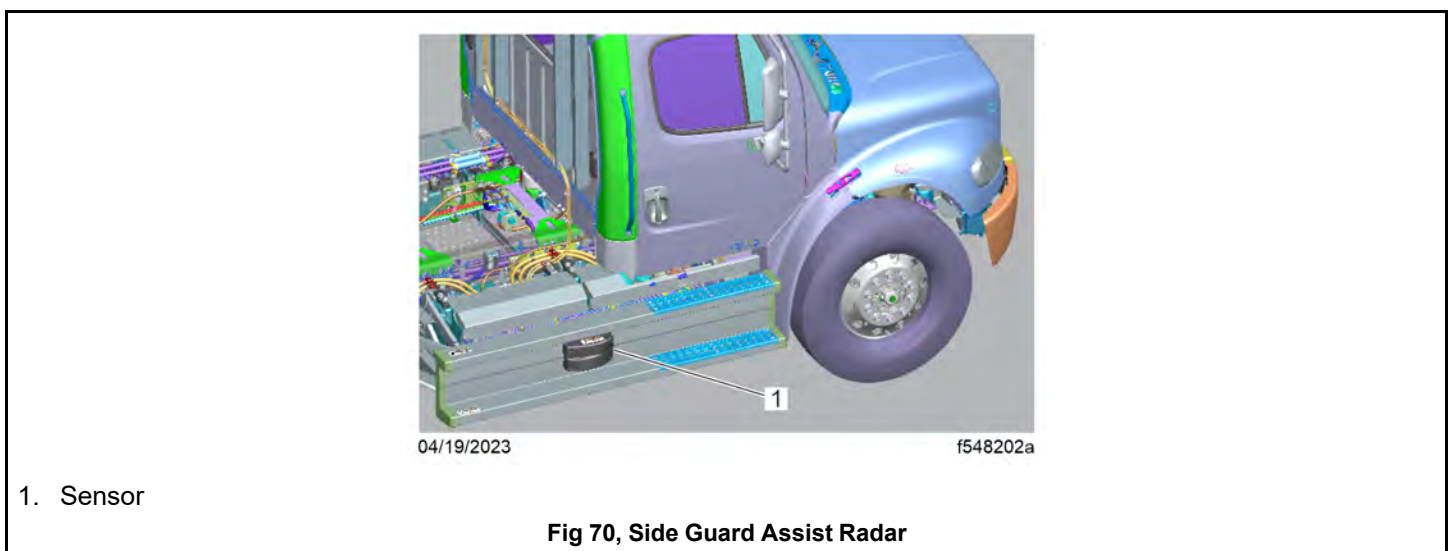

1. Sensor

As an object is assessed, the system alerts with an amber caution triangle. If there is a risk of collision, the color changes to red and a warning tone sounds. Under certain conditions while turning at urban speeds and there is a risk of collision with a moving pedestrian or bicyclist, the ASGA activates the brakes automatically.



1. Side Gard Assist Warning Lamp

Fig 71, Passenger Side A Pillar

7.08.02 Safety Information

SGA and ASGA are only aids for a conscientious driver. These guidelines serve as reminders for situations in which the driver must be especially alert and attentive. ASGA relies on SGA, if SGA is impaired, ASGA cannot provide notifications or assist during low speed, passenger-side turns when a critical object is present.

Before driving the vehicle, ensure the radar sensor cover is free from dirt, ice, or slush. If the sensors get dirty while driving, the telltale on the driver display may change from a grey triangle indicating active SGA to a grey triangle with a slash. In this case, pull off to a safe location to clean them. The radar sensors must be free of paint or other coverings such as stickers.



WARNING:

If detection is impaired, SGA may issue a warning too late or not at all. The following conditions can restrict detection of obstacles:

- **dirty, icy, or obscured sensors**
- **very wide lanes**
- **vehicles not driving in the middle of their lane**
- **barriers or other road boundaries**

The risk of an accident is increased in these situations.

The driver must pay attention to the traffic situation and maintain a safe distance at the side of the vehicle.

IMPORTANT: If the sensors are dirty or SGA malfunctions, a grey triangle alert icon with a slash or exclamation mark appears on the driver display. SGA has stopped tracking objects in the monitoring range and notifications are not available

Depending on the situation, SGA may issue a warning prematurely or not at all. In addition to unobstructed sensors, always ensure the distance to the side for other vehicles, cyclists, pedestrians, and obstacles is sufficient.

Be cautious and attentive in the following scenarios. SGA notifications may be delayed, inactive, in error, or interrupted.

- May be inactive a short duration after coupling; the ability to activate it is delayed.
- May be inactive for a short duration after pulling away from a loading dock.
- During passenger-side turns, monitoring becomes limited for the back corner or bumper. Extra attentiveness is required.
- Inactive on objects within approximately 6 inches of the passenger-side of the vehicle. Objects within this area are not detected.
- In error when driving close to barriers or other solid boundaries. For example driving through construction sites, see [Activating and Deactivating SGA](#) for more information.
- Interrupted during prolonged driving alongside particularly long vehicles.

See an authorized dealer to have the function of the radar sensors checked if any of the following circumstances are true:

- If the vehicle is involved in a severe accident.
- If there is damage to the passenger-side footsteps.
- If the needs servicing telltale, a grey triangle with an exclamation mark, appears in the driver's display.
- If SGA malfunctions.

The active monitoring areas are shown in Fig. 72, [Sensor Monitoring Area of SGA](#).

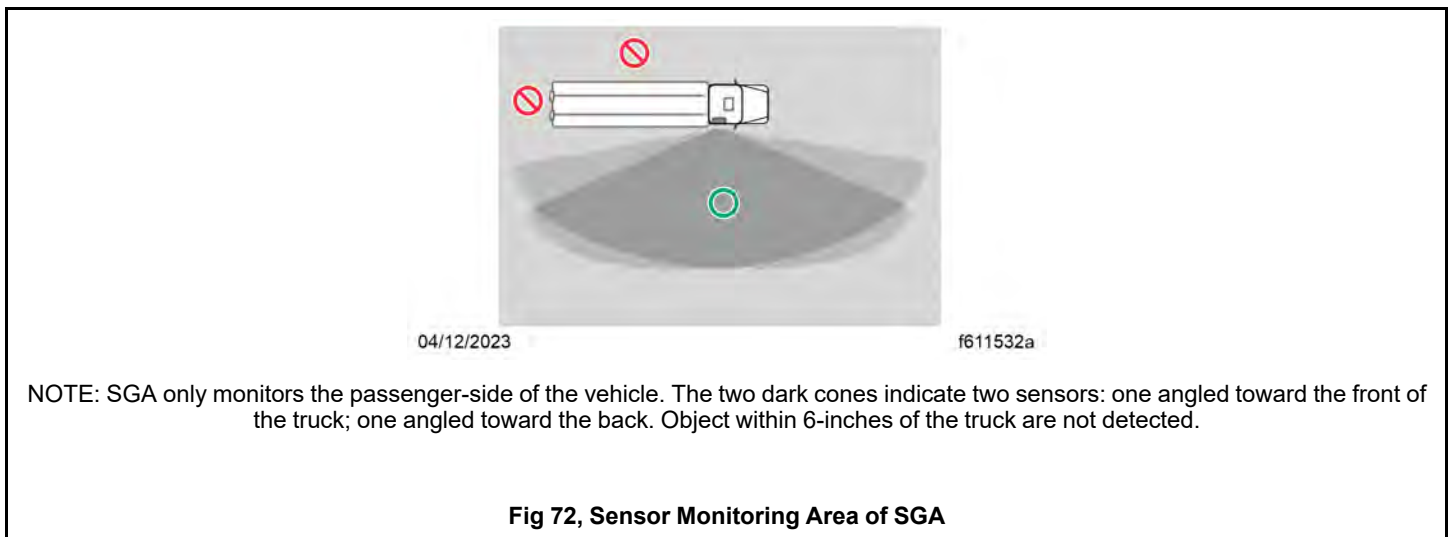

7.08.03 Sensor Monitoring Range of SGA

IMPORTANT: The optional enhancement, ASGA, reacts only to objects within SGA's sensor monitoring area as shown in Fig. 73, [Sensor Monitoring Area of SGA](#).

The sensor monitoring range is the area on the passenger-side of the vehicle that the sensors can assess for proximity to moving objects and stationary obstacles.

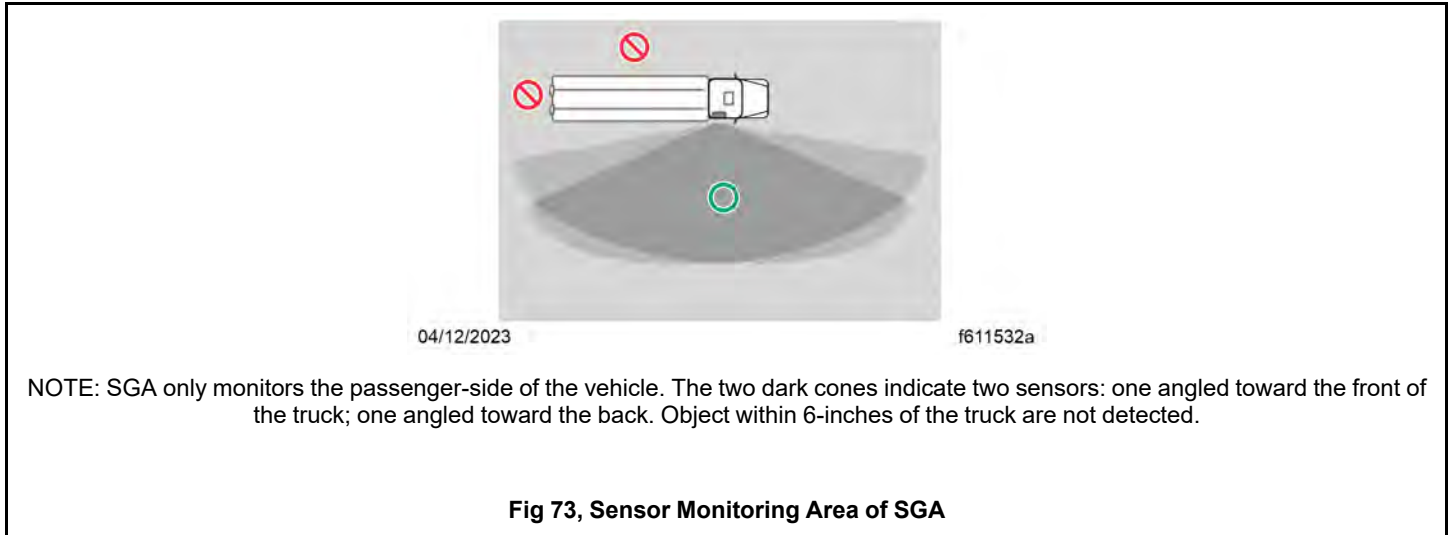

7.08.04 SGA Telltales

NOTE: The telltales described as grey may appear white depending on the type of instrument panel installed in the vehicle. Amber telltales raise awareness of an object. Red telltales warn of a possible collision.

On start up, the driver knows the vehicle is equipped with SGA if the SGA icon appears in the Detroit Assurance screen along with ABS. An SGA initializing telltale, the first telltale in Table 19, [Side Guard Assist Telltales](#) appears on the driver display as the startup sequence continues.

If SGA monitoring experiences an error or is deactivated a grey triangle with a slash appears.

NOTE: When the transmission is shifted to reverse, SGA OFF telltale appears in the display until the transmission is shifted back to Neutral (N) or forward gears.

After SGA is turned off, it remains off until the driver turns SGA on using the driver display or by stopping and turning the vehicle off and on again. When the vehicle is running and SGA is turned off, the driver display shows the Side Guard Assist Error or Deactivation telltales shown in Table 19, [Side Guard Assist Telltales](#).

Alerts are color-coded to indicate severity. Red indicates a condition that may pose a threat to control of the vehicle. Amber indicates a condition that may result in damage to vehicle components. Grey is used for notices.



Name	Telltale	Color
Side Guard Assist Initializing		Grey
Side Guard Assist Active		Grey
Side Guard Assist Error or Deactivation		Grey

Table 19, Side Guard Assist Telltales



Name	Telltale	Color
Side Guard Assist Needs Servicing		Grey
Caution, Side Guard Assist		Amber
Warning, Side Guard Assist		Red

Table 7, Side Guard Assist Telltales

7.08.05 Activating and Deactivating SGA Alerts

SGA is automatically activated when the ignition is turned on. ASGA, if equipped, relies on SGA and is not controlled separately by the driver. ASGA engages at speeds less than 12 mph (19 km/h). If SGA detects a critical moving object in the sensor monitoring area along the side of the truck during a passenger-side turn, ASGA automatically applies the brakes.

Although monitoring is continuous, the audible and visual alerts can be deactivated fully or partially. With the default setting, SGA notifications are active for the vehicle. Stationary and moving objects detected within range activate cautions and warnings. The driver can turn SGA alerts off manually using the driver assistance settings in the driver display. See Fig. 74, [Deactivating SGA in the Driver Display, ICC5](#).

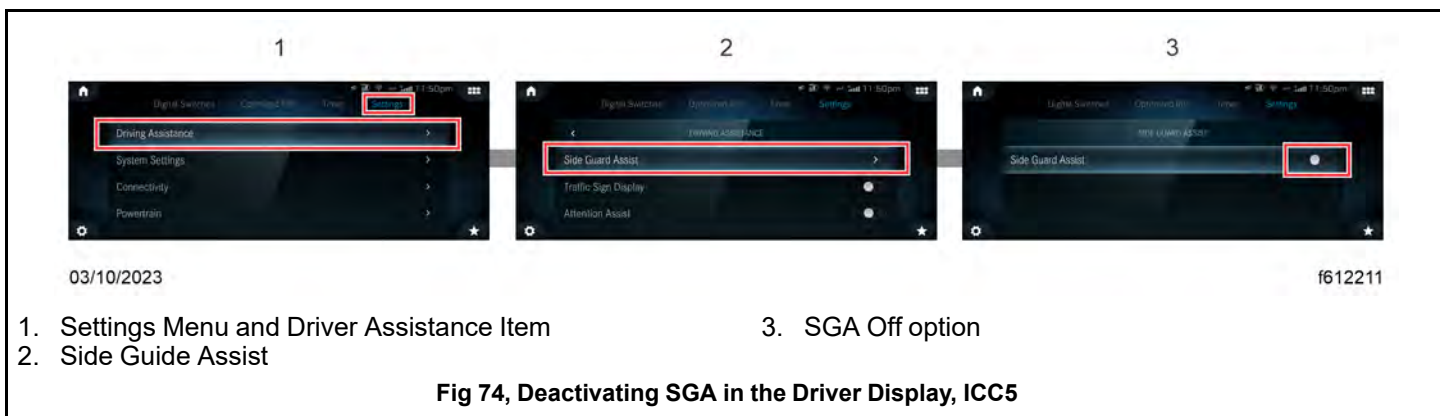

Fig 74, Deactivating SGA in the Driver Display, ICC5

In some operational conditions, such as construction zones, SGA may register false positives. A driver can override ASGA braking, by pressing the accelerator pedal beyond the pressure point to engage kickdown.

For common warning scenarios when SGA is activated, see Table 20, [Common Scenarios for Warnings While SGA and Trailer Assist are Activated](#).

Warning Scenarios	Driver Experience
 <p>10/11/2018 f611533</p>	<p>Moving object detected along side the vehicle and trailer.</p> <p>An amber SGA warning lamp in the A-pillar activates and the ICU displays the appropriate caution telltale.</p>
 <p>10/11/2018 f611534</p>	<p>Moving detected while turning.</p> <p>If the driver signals or steers to the passenger-side and there is a risk of collision with an object, the red SGA warning lamp in the A-pillar flashes for a few seconds, a warning tone sounds, and the appropriate SGA warning telltale on the driver display screen.</p> <p>After flashing, the red warning lamp stays on as long as there is a risk of a collision.</p> <p>If the vehicle is moving at urban speeds and equipped, ASGA automatically applies the brakes.</p>
 <p>03/21/2023 f612213</p>	<p>Limitations to detection of risk to the trailer's back corner while turning.</p> <p>The ability of SGA and ASGA to detect and react to stationary objects alongside the end of the trailer as it completes a passenger-side turn is limited. If the driver steers to the passenger-side there is a risk of collision without notification when the end of the trailer and its bumper reaches a stationary object.</p>
 <p>10/11/2018 f611535</p>	<p>Moving object detected by vehicle sensor before a lane change.</p> <p>If a moving object is in SGA monitoring range when a driver signals or steers to the passenger-side, an amber warning lamp activates in the A-pillar and the appropriate SGA caution telltale appears on the driver display screen.</p> <p>If there is a risk of collision, the red warning lamp in the A-pillar flashes, a warning tone sounds, and the appropriate SGA warning telltale appears on the driver display screen. The red warning lamp stops flashing after a few seconds but stays on as long as there is a risk of a collision.</p>

Table 8, Common Scenarios for Warnings While SGA and Trailer Assist are Activated



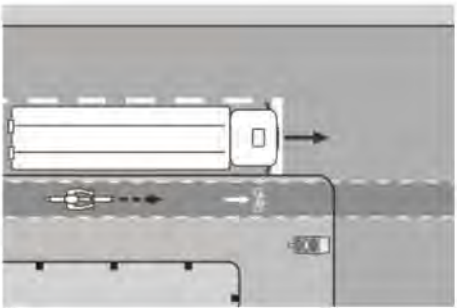
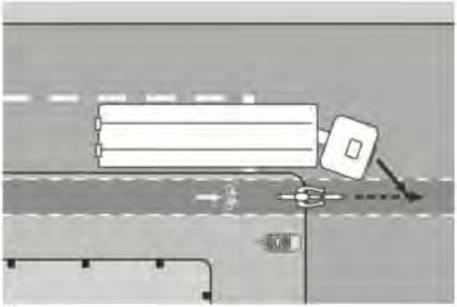
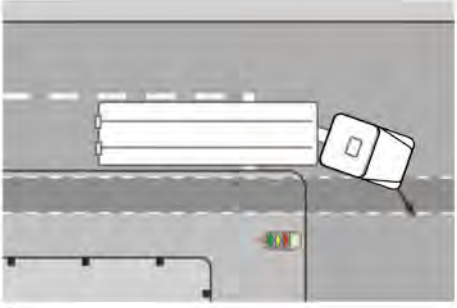
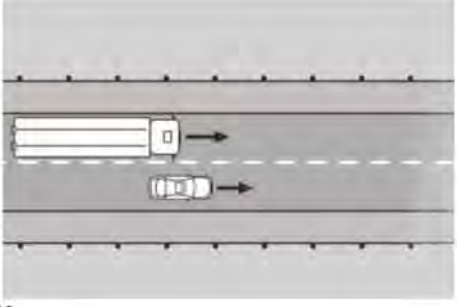

7.09 Detroit Assurance Telltales

Telltales and messages appear on the driver display. The positions of the telltales vary, but most use standard symbols.

The colors of telltales indicate the hazard level as follows: red (warning), amber (caution), green (normal function), blue (active status), grey (passive status), white (informational).

The colors of messages indicate the hazard level as follows: red (warning), amber (caution), grey (informational).

Telltales for Detroit Assurance features are listed in Table 21, [Detroit Assurance Telltale Lamps and Messages](#) . Every vehicle may not be equipped with every feature.

Telltale	Color	Description		Related Messages
	Green	Adaptive Cruise Control (ACC) Active	Indicates that adaptive cruise control is on and active.	
	Amber	Adaptive Cruise Control Unavailable	Indicates that Adaptive Cruise Control (ACC) is not available	
	Amber	Active Brake Assist Unavailable	Indicates the Active Brake Assist system is not available.	
	Amber	Lane Departure Warning Unavailable	Indicates that lane departure warning is disabled due to minimum speed, lack of lane markings, or system not being available.	
	Red	Auto Stop Active	<p>When Auto Stop activates at the end of the Lane Keep Assist warning cascade, the Auto Stop telltale appears.</p> <p>When Auto Stop has brought the vehicle to a standstill, the Auto Stop telltale clears.</p>	<p>The Auto Stop warning window: "Auto Stop Started Throttle to Cancel" appears when Auto Stop initiates.</p>

8.01 Electronic Stability Control (ESC)	110
8.02 Electronic Stability Control (ESC)	110
8.03 PasSmart	111
8.04 SafetyDirect® by Bendix	111

8. Driver Assistance Features

8.01 Electronic Stability Control (ESC)

8.02 Electronic Stability Control (ESC)



WARNING:

Electronic stability control (ESC) is intended only as an aid for a conscientious and alert driver. Carefully read the information in this manual to understand this system and its limitations. ESC is not a substitute for safe driving procedures. Failure to drive safely, and use the system properly, could result in personal injury and/or death and property damage.



CAUTION:

Changing or modifying the location of the ESC sensor or reconfiguring the vehicle, such as by changing the wheelbase or adding axles, can change the performance of the enhanced stability control system and may result in product or property damage and personal injury.

Electronic stability control (ESC) works by constantly comparing the driver's intention with the vehicle's actual behavior. The system does this by monitoring wheel speed, steering angle, yaw rate, lateral acceleration, throttle position, and brake application. A central microcomputer analyzes the collected data and triggers a response to keep the vehicle on course when an unstable condition is detected.

When the system detects that the vehicle is at risk of over-steering or under-steering, it applies individual tractor wheel end brakes and trailer brakes and/or cuts power to reduce the likelihood of a drift-out or jackknife.

If the acceleration sensor detects the vehicle is at risk of rolling over, the roll stability control system within the ESC automatically reduces power and applies the brakes.

Yaw control is not active below approximately 6 mph (10 km/h). Roll stability control is not active below approximately 12 mph (20 km/h). At higher speeds, ESC operates automatically; the driver does not monitor or activate the system.

The driver has full control over the vehicle until the system detects a potential risk and intervenes accordingly.

The ESC telltale, as shown, see Fig.75, [Electronic Stability Control \(ESC\) Telltale](#), appears on the driver display when ESC intervenes and when ESC is unavailable due to a fault. The ESC telltale flashes when an ESC event is actively occurring and is solidly illuminated when ESC is unavailable due to a fault.



03/09/2022

f612013

Fig 75, Electronic Stability Control (ESC) Telltale

It is normal for the ESC telltale to illuminate shortly after a curve, lane change, or other driving maneuver that results in ESC detecting a rollover-risk.

8.03 PasSmart

A standard feature on fleet vehicles, PasSmart enables a vehicle to exceed a set speed limit by a limited amount to allow for passing vehicles on the highway. For example, a PasSmart vehicle may be programmed to enable the vehicle to travel 5mph over a set speed limit for 30 minutes every 24 hours. This speed limiting increases overall fuel economy.

If equipped, the PasSmart function is initiated by double-pumping the accelerator pedal within a two second period. When initiated, the PasSmart window as shown, see Fig.76, [PasSmart Active Window, ICC5](#). appears. The PasSmart timer shown in this window starts when the road speed limit is exceeded by 1.89 mph (3 km/h).

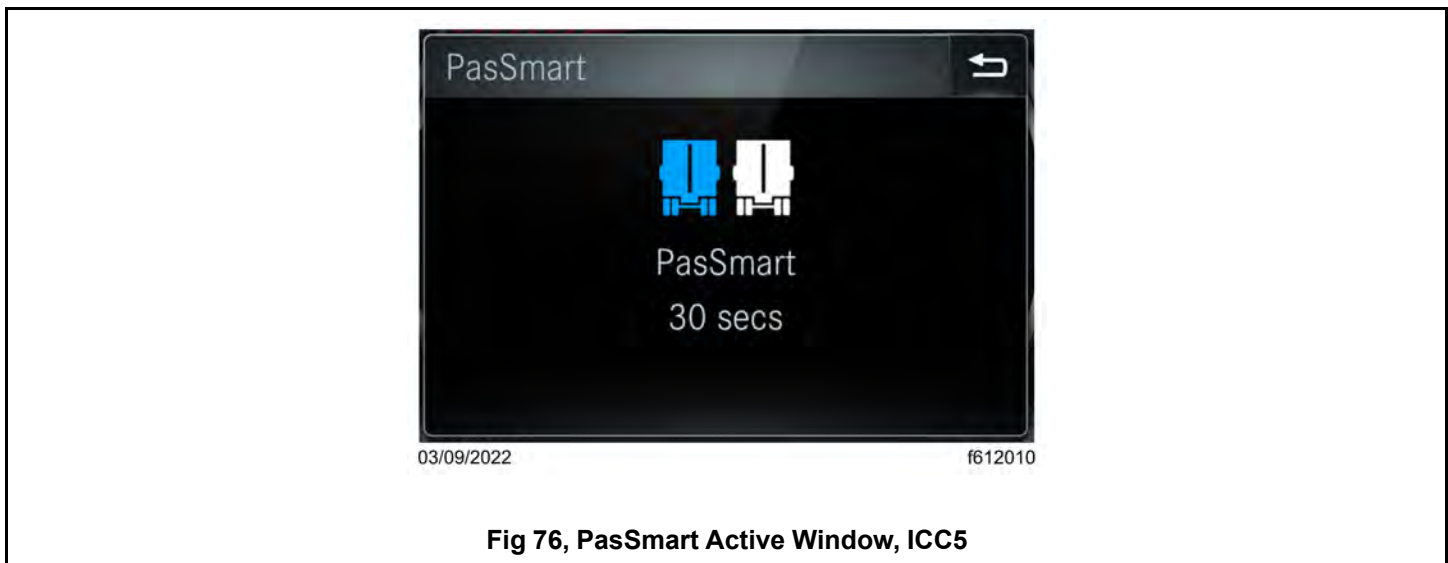

PasSmart does not disengage cruise control. After engagement, PasSmart deactivates when the speed limit of the vehicle drops below the cruise control standard set speed limit at which point cruise control resumes.

Thirty seconds before a daily PasSmart limit is reached, the PasSmart active window, if closed, opens to notify the driver of the time remaining.

8.04 SafetyDirect® by Bendix

IMPORTANT: In order for the forward facing camera to operate properly, the windshield area in front of the camera must be clean, unobstructed, and not be damaged in any way.

SafetyDirect by Bendix is a fleet management system that automatically records ten to twenty seconds of video during a safety event, and delivers it and other vehicle safety data to the Bendix SafetyDirect portal. An optional Bendix forward facing 5G camera that works in tandem with the Detroit Assurance MPC2 camera is an available option. If equipped, the Bendix camera appears as shown, see Fig.77, [MPC2 and Bendix Camera](#).

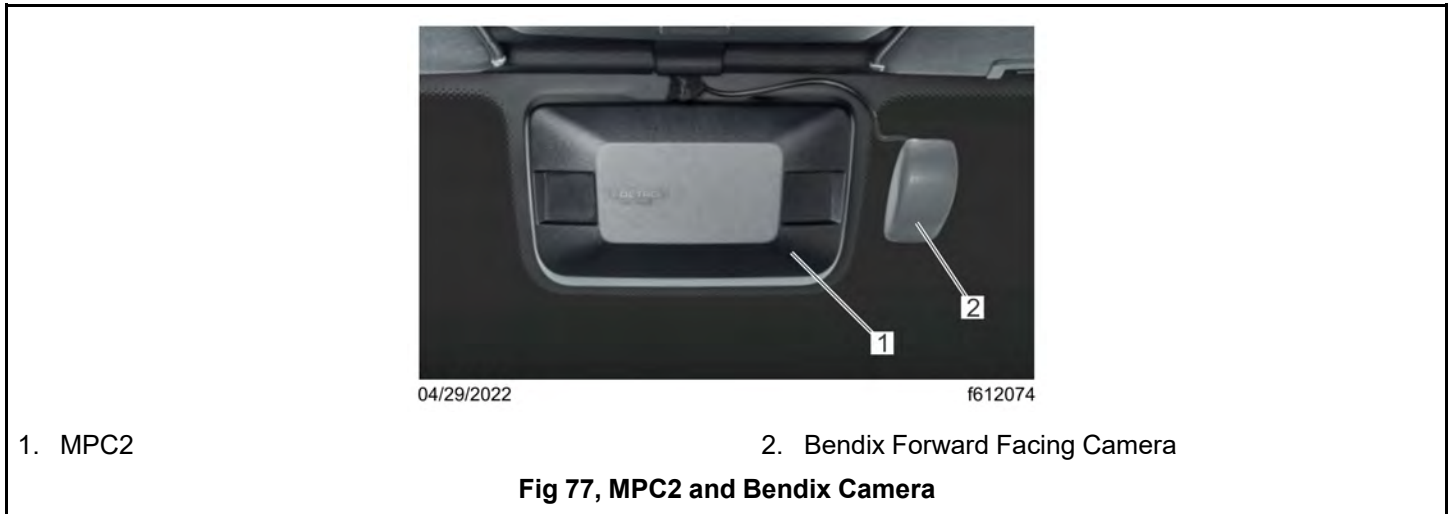

The Bendix Safety Direct system integrated with Detroit Assurance is configured to record videos and event data for the following events:

- lane departure warning;
- loss of video tracking;
- collision mitigation braking;
- excessive braking;
- excessive speed on curves;
- electronic-stability control braking;
- rollover-stability control braking.

The driver can manually trigger an event recording at any time. Press and hold the lane-departure warning (LDL) Enable/Disable rocker switch in the dash until an audible alert from the instrument cluster (a single beep) is heard, to indicate that the event has successfully been captured by the SafetyDirect ECU.

Other supported events that do not include a video record can be viewed on the SafetyDirect portal by going to Dashboards/Event Dashboard then unchecking the 'Events with Video' check box.

9.01 Sitting Posture	114
9.01.01 Sitting Posture	114
9.01.02 ISRI Elite High Back Seat	114
9.01.03 ISRI Premium High Back Seat	119
9.01.04 ISRI Basic High Back Seat.....	121
9.01.05 Seat Belts and Tether Belts.....	123
9.01.06 Steering Wheel Air Bag	128
9.01.07 Passenger Safety Telltales.....	129

9. Seats and Restraints

9.01 Sitting Posture

9.01.01 Sitting Posture

Before driving, adjust the seat to support good sitting posture as shown, see Fig.78, [Correct Seating Posture](#). Good posture supports the safe operation of the vehicle and the driver's fitness and comfort. When correctly seated, all instruments and controls should be within easy reach and the driver should have a clear view of the road and mirrors.

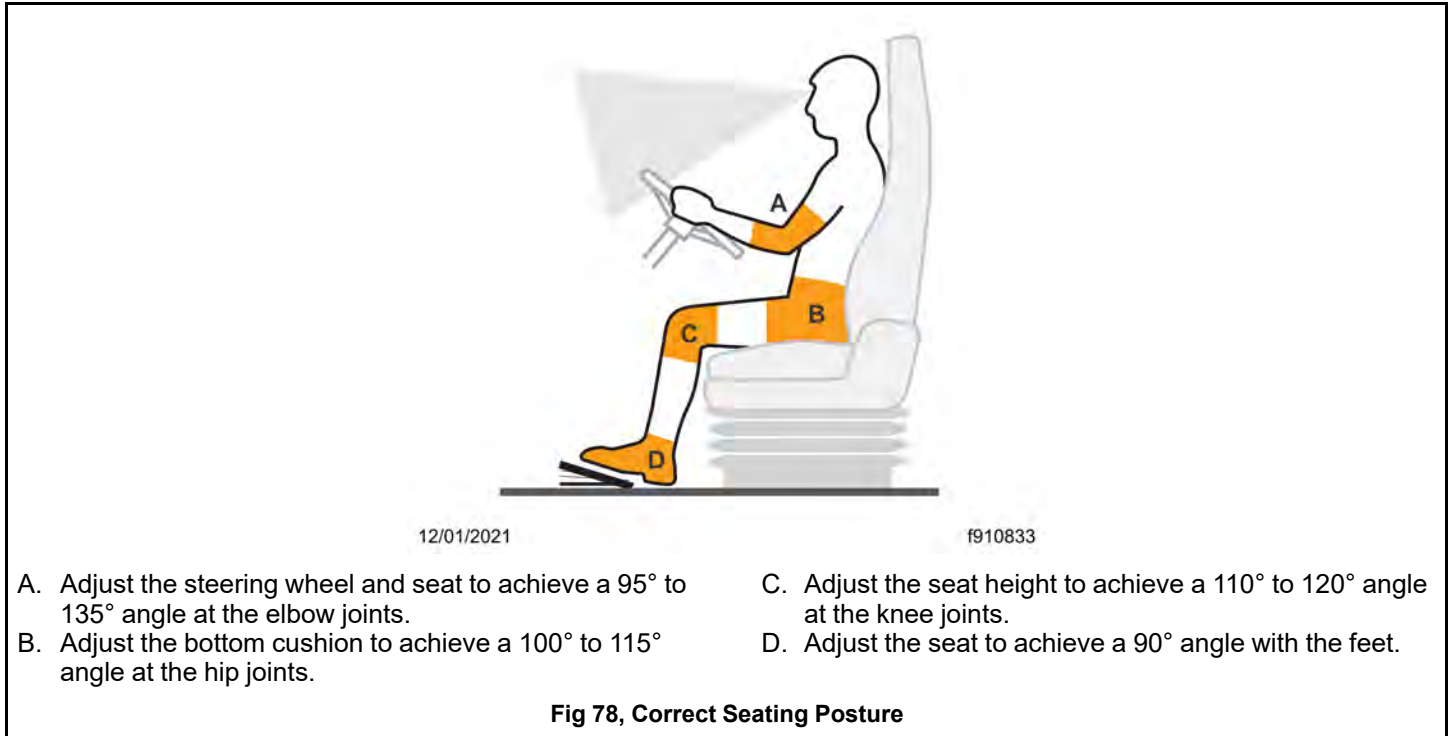

9.01.02 ISRI Elite High Back Seat

NOTE: The seat should only be adjusted when the vehicle is parked.

The seat is designed to hold a maximum weight of 330 lb.

The ISRI Elite seat has ten different features; the controls are as shown, see Fig.79, [ISRI Elite High Back Seat](#).

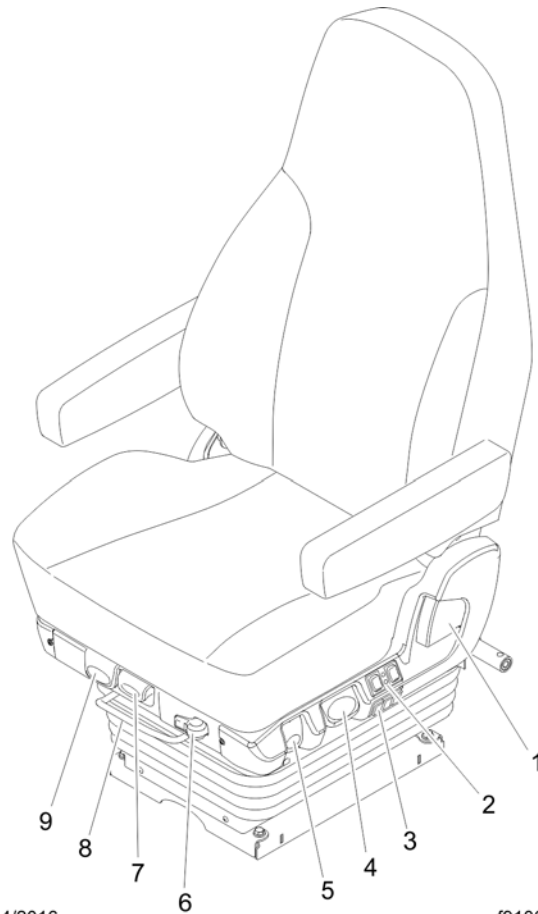

01/14/2016

f910682b

- | | |
|----------------------|----------------------|
| 1. Backrest Tilt | 6. Fore/Aft Isolator |
| 2. Heat/Ventilation | 7. Seat Extension |
| 3. Back/Side Support | 8. Fore/Aft Slide |
| 4. Height Adjustment | 9. Seat Tilt Lever |
| 5. Damper Adjustment | |

Fig 79, ISRI Elite High Back Seat

1. **Backrest Tilt:** Pull the handle out completely and lean back or forwards to adjust the backrest tilt. Release the handle when the correct position is achieved. The backrest has a 52 degree range of movement.

When adjusted, the backrest inclination should allow the driver to reach the steering wheel with angled arms.

**NOTICE:**

Do not install seat covers on seats with heating and ventilation. Do not cover the seat with blankets, clothing, or pillows. Blocking the air flow through the cushions can cause the seat to overheat and damage the seat.

Do not run the seat heating or ventilation when the seat is unoccupied.

2. **Heat/Ventilation:** There are three heat or ventilation settings available as shown, see Fig. 80, [ISRI Elite Seat Heat/Ventilation Controls](#). Toggle the rear button to adjust the level of seat heating or ventilation.

Heat: To turn on the heat, push the top of the forward switch as shown, see Fig. 80, [ISRI Elite Seat Heat/Ventilation Controls](#). The red light next to the switch illuminates.

A sensor located in the seat controls the temperature and turns the heat off when the desired temperature is reached. Body size and clothing can affect how quickly the seat achieves the set temperature.

Ventilation: To turn on the ventilation, push the bottom of the forward switch as shown, see Fig. 80, [ISRI Elite Seat Heat/Ventilation Controls](#). The blue light next to the switch illuminates.

Two fans draw cabin air into the seats to reduce perspiration. Ventilation should not be run continuously.

To turn off the heat and ventilation, move the switch to the middle position.

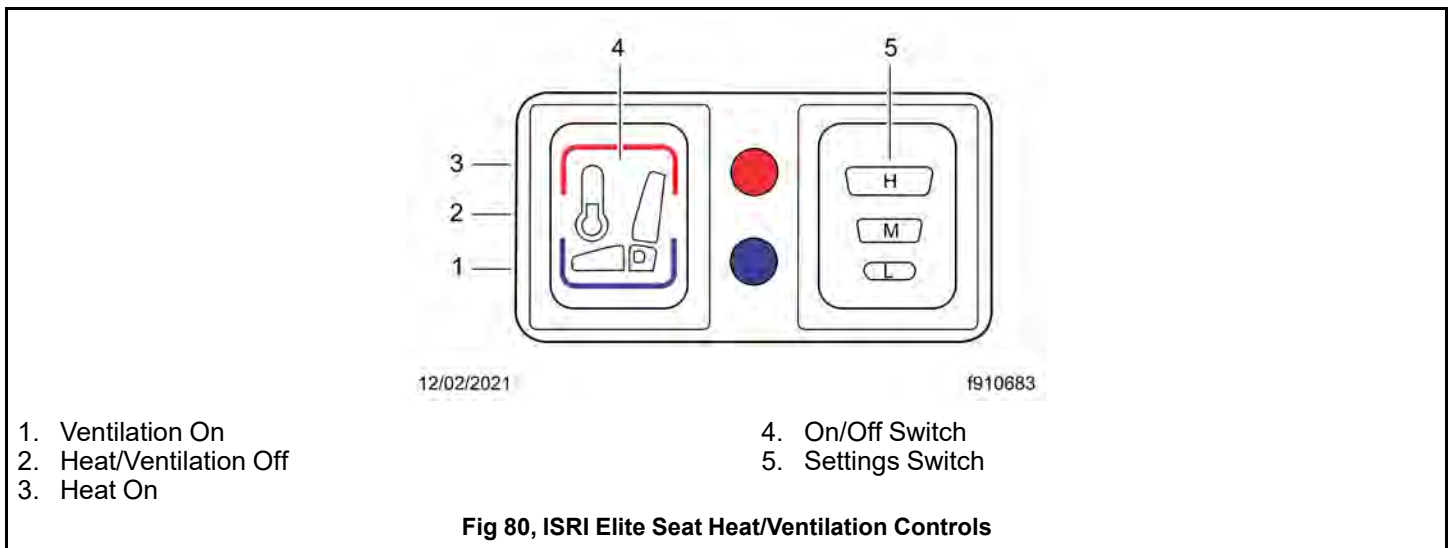

3. **Back and Side Support:** There are three switches that control the back and side support areas of the seat. Making changes to a driver's sitting position from time to time helps prevent driver fatigue and improves posture.
 - 3.a **Lumbar (Lower) Back Support:** Press the forward button to inflate the cushion highlighted in see Fig. 81, [Lower Back Support](#) to increase support at the lower back. This moves the driver's spine into a double S shape and decreases pressure on the spine.



- 3.b *Upper Back Support:* Press the central button to inflate the cushion highlighted in see Fig. 82, [Upper Back Support](#) to increase support at the mid-back region. This can help prevent the driver from sitting in a slouched, hunched, or hollow-back position.

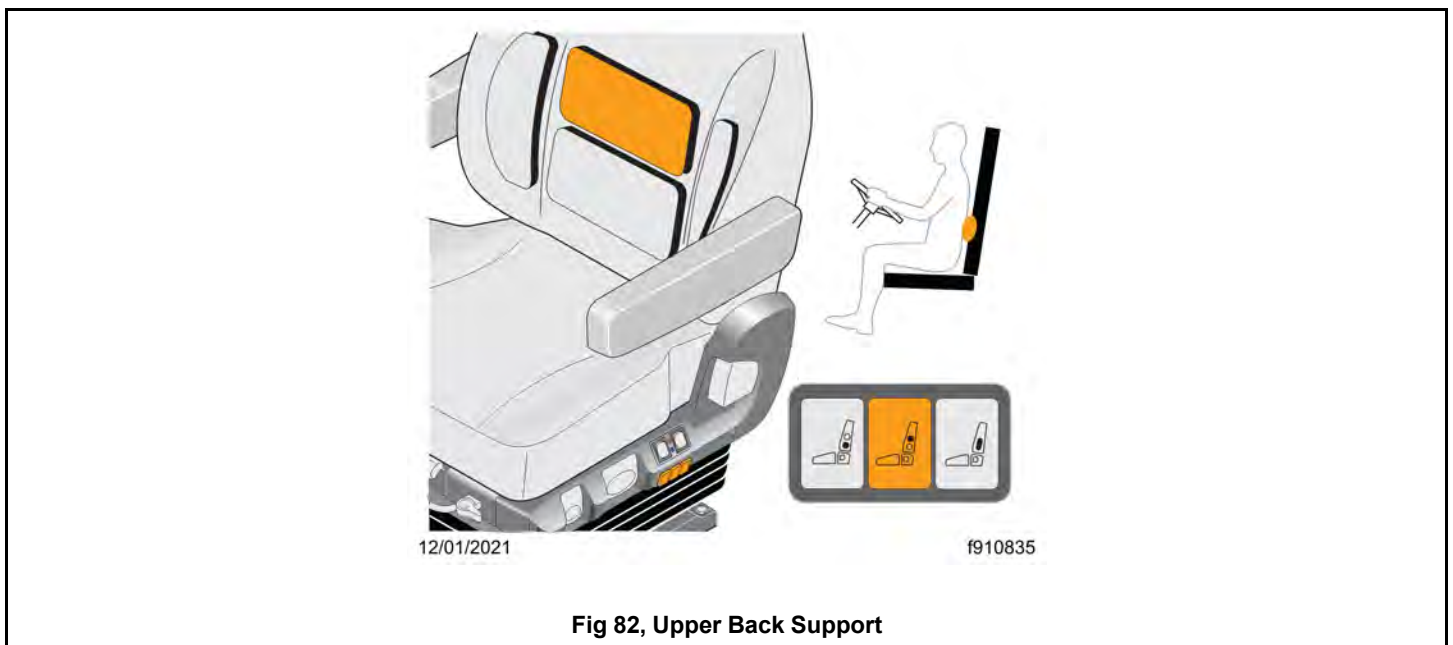

- 3.c *Side Support:*

Inflate the side bolster's as shown, see Fig.83, [Side Support](#) to help prevent driving in slouched position and from sliding across the backrest.

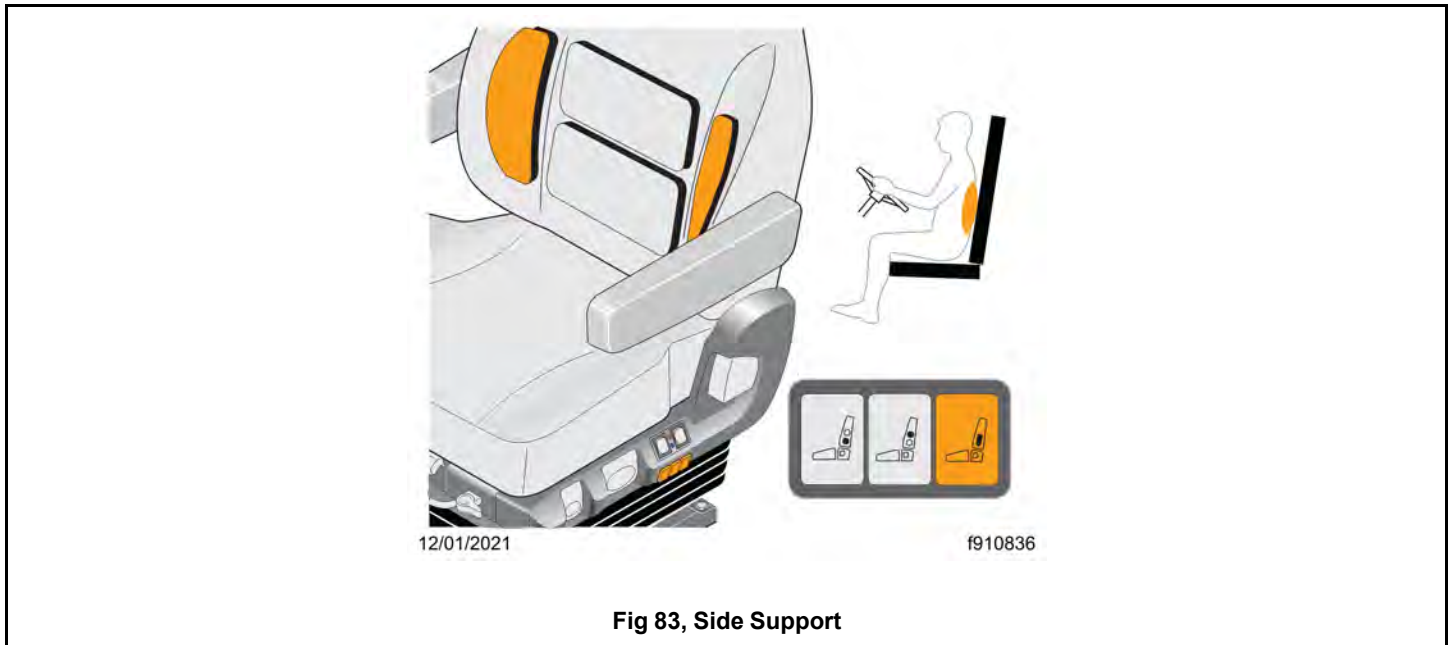

Fig 83, Side Support

4. **Height Adjustment:** Pull or push the handle to adjust the seat height.
Adjust the seat so the driver's feet can move each pedal through its full range of motion without fully stretching out the driver's legs or using force.
5. **Damper Adjustment:** Move the lever down to increase damping on rough roads, or up to decrease damping on flat roads.
The damper protects the driver's spine by absorbing vertical vibrations and shocks. It should be adjusted down far enough that the driver's feet never lose contact with the pedals. In general, heavier drivers won't have to adjust the lever up.
6. **Fore/Aft Isolator:** Rotate the isolator lever to the left to lock the isolator, or to the right to allow horizontal movement.
Damping horizontal shocks can be helpful with driving off-road or pulling a tank trailer.
7. **Seat Extension:** Pull the lever to move the seat cushion forwards or back. The cushion moves up to 2-3/8 inches (60 mm) in 3/8-inch (10-mm) increments. Releasing the lever locks the cushion in place.
Adjust the length of the seat cushion until there is space for three fingers between the cushion's front edge and the back the driver's knee. This helps to help improve circulation in the lower legs.
8. **Fore/Aft Slide:** Pull the lever to unlock the seat and slide it forward or back. Release the lever to lock the seat in position.
Adjust the seat so that reaching and pressing the pedals requires no effort and all dashboard controls are within easy reach.
9. **Seat Tilt:** Pull the lever and add or reduce weight on the front area of the seat cushion to move it into one of three positions. Release the lever to lock the seat into position.
The tilt of the seat, along with the tilt of the backrest and the contour of the seat cushion, affects the amount of pressure placed on the underside of the thighs and the back.
10. **Armrest Tilt:** To adjust the armrest angle, tilt the armrest to the highest position, then down to the lowest position, then to the desired position.
The armrest should be at an angle where the elbows lay lightly on it; this helps to relax the muscles in the shoulder and neck.

9.01.03 ISRI Premium High Back Seat

NOTE: The seat should only be adjusted when the vehicle is parked with the park brake on.

The seat is designed to hold a maximum weight of 330 lb.

The ISRI Premium seat has nine different features; the controls are as shown, see Fig.84, [ISRI Premium High Back Seat](#).

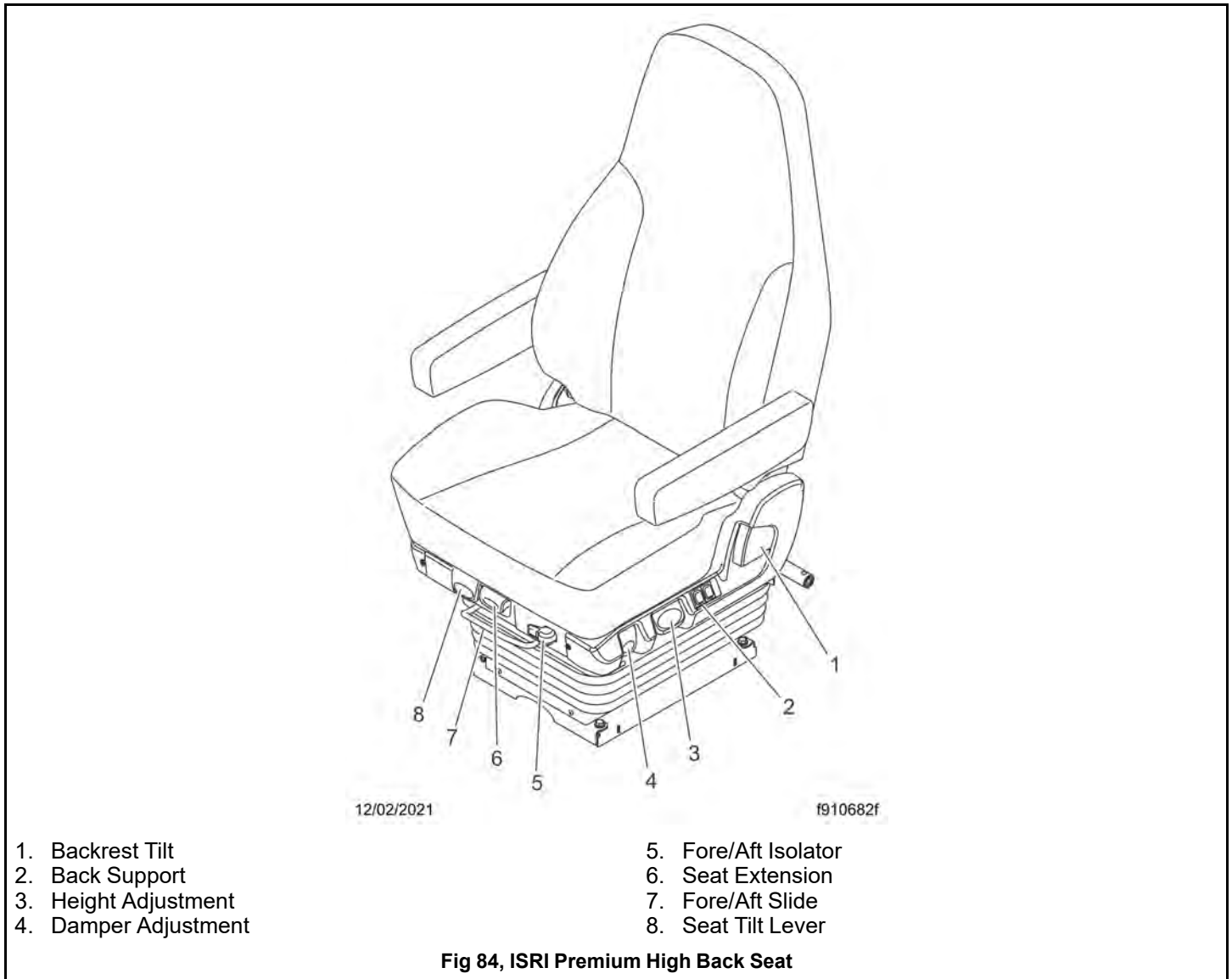

1. **Backrest Tilt:** Pull the handle out completely and lean back or forwards to adjust the backrest tilt. Release the handle when the correct position is achieved. The backrest has a 52 degree range of movement.
When adjusted, the backrest inclination should allow the driver to reach the steering wheel with angled arms.
2. **Back Support:** There are two switches that control the back areas of the seat. Making changes to a driver's sitting position from time to time helps prevent driver fatigue and improves posture.
 - 2.a **Lumbar (Lower) Back Support:** Press the forward button to inflate the cushion highlighted in see Fig. 85, [Lower Back Support](#) to increase support at the lower back. This moves the driver's spine into a double S shape and decreases pressure on the spine.

2.b *Upper Back Support*: Press the back button to inflate the cushion highlighted in see Fig.86, [Upper Back Support](#) to increase support at the mid-back region. This can help prevent the driver from sitting in a slouched, hunched, or hollow-back position.

3. **Height Adjustment**: Pull or push the handle to adjust the seat height.

Adjust the seat so the driver's feet can move each pedal through its full range of motion without fully stretching out the driver's legs or using force.

4. **Damper Adjustment**: Move the lever down to increase damping on rough roads, or up to decrease damping on flat roads.

The damper protects the driver's spine by absorbing vertical vibrations and shocks. It should be adjusted down far enough that the driver's feet never lose contact with the pedals. In general, heavier drivers won't have to adjust the lever up.

5. **Fore/Aft Isolator**: Rotate the isolator lever to the left to lock the isolator, or to the right to allow horizontal movement.

Damping horizontal shocks can be helpful with driving off-road or pulling a tank trailer.

6. **Seat Extension**: Pull the lever to move the seat cushion forwards or back. The cushion moves up to 2-3/8 inches (60 mm) in 3/8-inch (10-mm) increments. Releasing the lever locks the cushion in place.

Adjust the length of the seat cushion until there is space for three fingers between the cushion's front edge and the back the driver's knee. This helps to help improve circulation in the lower legs.

7. **Fore/Aft Slide**: Pull the lever to unlock the seat and slide it forward or back. Release the lever to lock the seat in position.

Adjust the seat so that reaching and pressing the pedals requires no effort and all dashboard controls are within easy reach.

8. **Seat Tilt**: Pull the lever and add or reduce weight on the front area of the seat cushion to move it into one of three positions. Release the lever to lock the seat into position.

The tilt of the seat, along with the tilt of the backrest and the contour of the seat cushion, affects the amount of pressure placed on the underside of the thighs and the back.

9. **Armrest Tilt**: To adjust the armrest angle, tilt the armrest to the highest position, then down to the lowest position, then to the desired position.

The armrest should be at an angle where the elbows lay lightly on it; this helps to relax the muscles in the shoulder and neck.



9.01.04 ISRI Basic High Back Seat

NOTE: The seat should only be adjusted when the vehicle is parked with the park brake on.

The seat is designed to hold a maximum weight of 330 lb.

The ISRI Basic seat has eight different features; the controls are as shown, see Fig.87, [ISRI Basic High Back Seat](#).



12/02/2021

f910682e

- | | |
|----------------------|--------------------|
| 1. Backrest Tilt | 5. Seat Extension |
| 2. Low Back Support | 6. Fore/Aft Slide |
| 3. Height Adjustment | 7. Seat Tilt Lever |
| 4. Fore/Aft Isolator | |

Fig 87, ISRI Basic High Back Seat

- Backrest Tilt:** Pull the handle out completely and lean back or forwards to adjust the backrest tilt. Release the handle when the correct position is achieved. The backrest has a 52 degree range of movement.

When adjusted, the backrest inclination should allow the driver to reach the steering wheel with angled arms.
- Lumbar (Lower) Back Support:**

Press the forward button to inflate the cushion highlighted in see Fig.88, [Lower Back Support](#) to increase support at the lower back. This moves the driver's spine into a double S shape and decreases pressure on the spine.
- Height Adjustment:** Pull or push the handle to adjust the seat height.

Adjust the seat so the driver's feet can move each pedal through its full range of motion without fully stretching out the driver's legs or using force.
- Fore/Aft Isolator:** Rotate the isolator lever to the left to lock the isolator, or to the right to allow horizontal movement.

Damping horizontal shocks can be helpful with driving off-road or pulling a tank trailer.
- Seat Extension:** Pull the lever to move the seat cushion forwards or back. The cushion moves up to 2-3/8 inches (60 mm) in 3/8-inch (10-mm) increments. Releasing the lever locks the cushion in place.

Adjust the length of the seat cushion until there is space for three fingers between the cushion's front edge and the back of the driver's knee. This helps to help improve circulation in the lower legs.

6. **Fore/Aft Slide:** Pull the lever to unlock the seat and slide it forward or back. Release the lever to lock the seat in position.

Adjust the seat so that reaching and pressing the pedals requires no effort and all dashboard controls are within easy reach.

7. **Seat Tilt:** Pull the lever and add or reduce weight on the front area of the seat cushion to move it into one of three positions. Release the lever to lock the seat into position.

The tilt of the seat, along with the tilt of the backrest and the contour of the seat cushion, affects the amount of pressure placed on the underside of the thighs and the back.

8. **Armrest Tilt:** To adjust the armrest angle, tilt the armrest to the highest position, then down to the lowest position, then to the desired position.

The armrest should be at an angle where the elbows lay lightly on it; this helps to relax the muscles in the shoulder and neck.



Fig 88, Lower Back Support

9.01.05 Seat Belts and Tether Belts

Tether Belt Information

Tether belts are installed on suspension-type seats. Tether belts help secure the seat to the floor and are intended to restrain the seat and seat belt in case of an accident or sudden stop.

Seat Belt Information

Seat belt assemblies are designed to secure persons in the vehicle to help reduce the chance of injury, or the amount of injury, resulting from accidents or sudden stops. For this reason, Daimler Truck North America (DTNA) LLC urges that the driver and *all* passengers, regardless of age or physical condition, use seat belts when riding in the vehicle.

As a reminder for the driver, if equipped, when the parking brake is released and the driver's seat belt is unfastened, the red seatbelt unfastened telltale as shown, see Fig.89, [Seatbelt Unfastened Telltale](#), lights up on the driver display screen and a audible alert is activated.

**WARNING:**

Always use the vehicle's seat belt system when operating the vehicle. Failure to do so can result in severe personal injury or death.

Seat belt assemblies in DTNA vehicles meet Federal Motor Vehicle Safety Standard 209, 'Type 1' and 'Type 2' requirements.

When transporting a child, always use a child restraint system or the vehicle seat belts as appropriate. To determine whether a child restraint system is required, review and comply with applicable state and local laws. Any child restraint used must comply with Federal Motor Vehicle Safety Standard 213, "Child Restraint Systems." When providing a child restraint system, always carefully read and follow all instructions pertaining to installation and usage for the child. Make certain the child remains in the restraint system at all times when the vehicle is in motion.

IMPORTANT: Seat belts have a finite life which may be much shorter than the life of the vehicle. Regular inspections and replacement as needed are the only assurance of adequate seat belt security over the life of the vehicle.

Inspection of the Seat Belt

**WARNING:**

Inspect and maintain seat belts. When any part of a seat belt system needs replacement, the entire seat belt must be replaced, both retractor and buckle side. Any time a vehicle is involved in an accident, and the seat belt system was in use, the entire vehicle seat belt system must be replaced before operating the vehicle. Do not attempt to modify the seat belt system; doing so could change the effectiveness of the system. Failure to replace worn or damaged seat belts, or making any modifications to the system, may result in personal injury or death.

Inspect the seat belts and tether belts (if so equipped).

1. Check the web for fraying, cuts, extreme dirt and dust, or for severe fading from exposure to sunlight, especially near the buckle latch plate and in the D-loop guide area.
2. Check operation of the buckle, latch, web retractor, and upper seat belt mount on the door pillar. Check all visible components for wear or damage.
3. Check the seat belt and tether belt connection points and tighten any that are loose.

Seat Belt Operation

Fastening the Seat Belt

NOTE: Wear three-point seat belts only as described below. Three-point seat belts are designed to be worn by one person at a time. In case of an accident or sudden stop, personal injury or death could result from misuse. Fasten the seat belts before driving. Fastening a three-point seat belt while driving creates a hazard.

1. If needed, adjust the seat to achieve the proper driving position.
2. Slowly pull the link end of the seat belt out of the retractor and pull it across your lap (from outboard to inboard) far enough to engage the buckle. If the retractor locks too soon, allow the belt to retract slightly, then slowly pull it out again. See Fig.90, [Three-Point Seat Belt Operation](#).

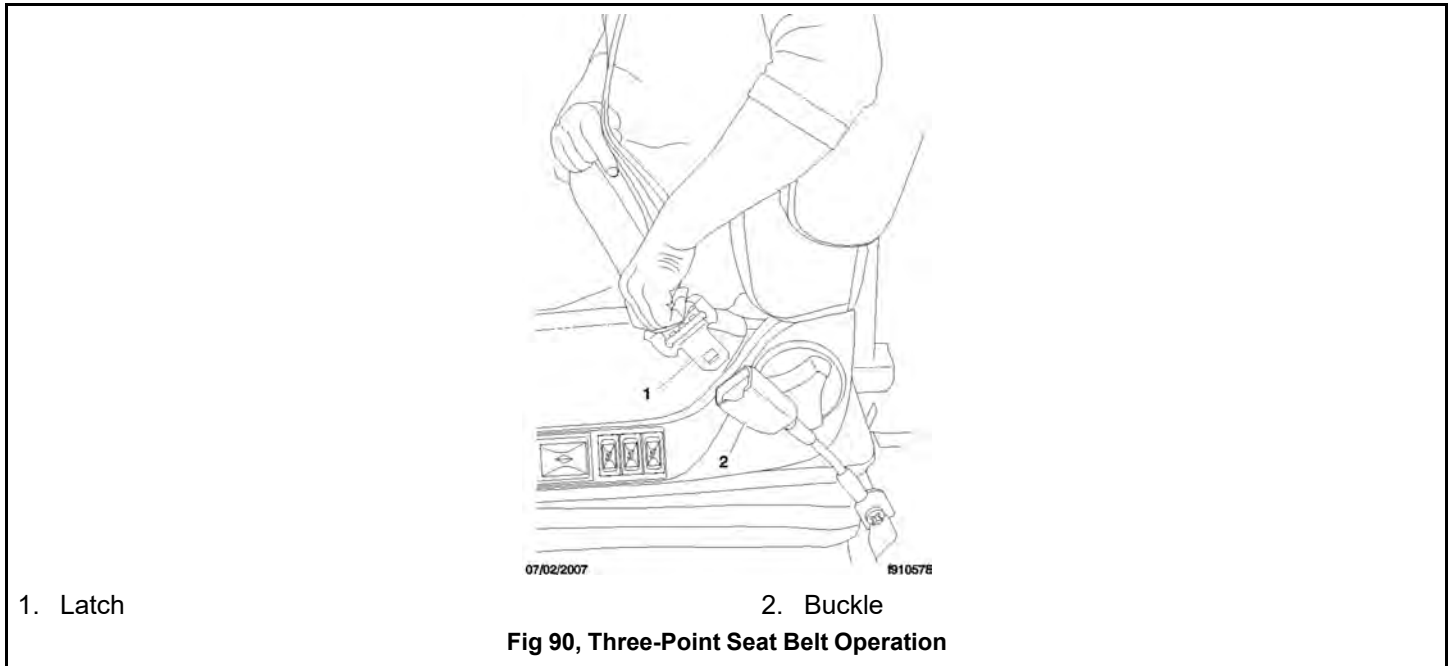

3. Fasten the seat belt by pushing the latch into the buckle. Listen for an audible click.
4. Tug on the seat belt to make sure it is securely fastened. If the buckle unlatches, repeat this step. If the problem continues, replace the seat belt.
5. Snug the seat belt to your waist.
6. If equipped with a seat belt height adjuster, adjust it to position the shoulder strap diagonally across your chest. See Fig.91, [Adjusting the Seat Belt Height](#). The shoulder strap must be centered on your shoulder and chest, away from your face and neck as shown, see Fig.92, [Proper Shoulder Strap Fit](#).

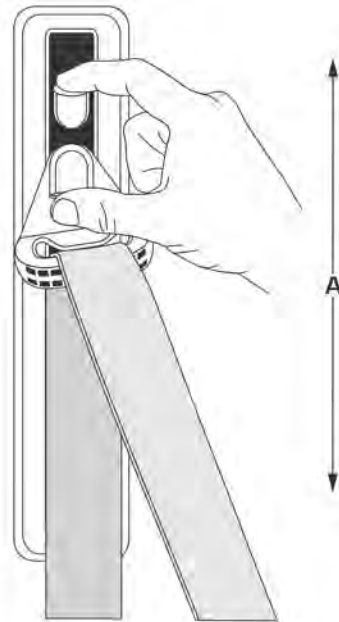

04/27/2023

f910887

- A. Pinch the top and bottom height adjuster levers together, then move the shoulder loop to a comfortable height.

Fig 91, Adjusting the Seat Belt Height

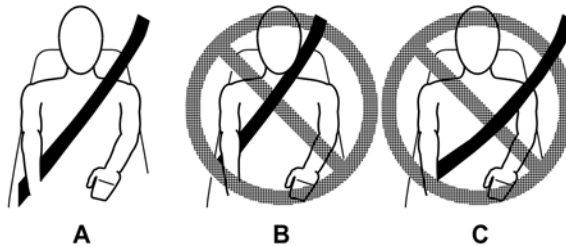

02/03/2017

f910634

- A. Correct—Belt is centered on your shoulder and chest, away from your face and neck.
- B. Wrong—Belt must not rub against your face or neck.
- C. Wrong—Belt must not hang off your shoulder.

Fig 92, Proper Shoulder Strap Fit



WARNING:

Before activating a Komfort Latch, make sure the amount of slack in the shoulder strap is set as described. Excess slack in the shoulder strap reduces the effectiveness of the seat belt, and increases the risk of injury or death in an accident.

7. The Komfort Latch allows a small amount of slack into the seat belt, resulting in a more comfortable ride.

To use the Komfort Latch, open the cover as shown, see Fig.93, [Unlocked Komfort Latch](#) Pull on the shoulder strap to create 1 inch (2.5 cm) of space between your chest and the strap as shown, see Fig.

94, [Adjusting Shoulder Harness Clearance for the Komfort Latch](#). Allow no more than 1 inch (2.5 cm) of slack as more slack can significantly reduce the seat belt effectiveness. While holding the belt slack, press the Komfort Latch lever up to lock it, as shown, see Fig.95, [Locked Komfort Latch](#).

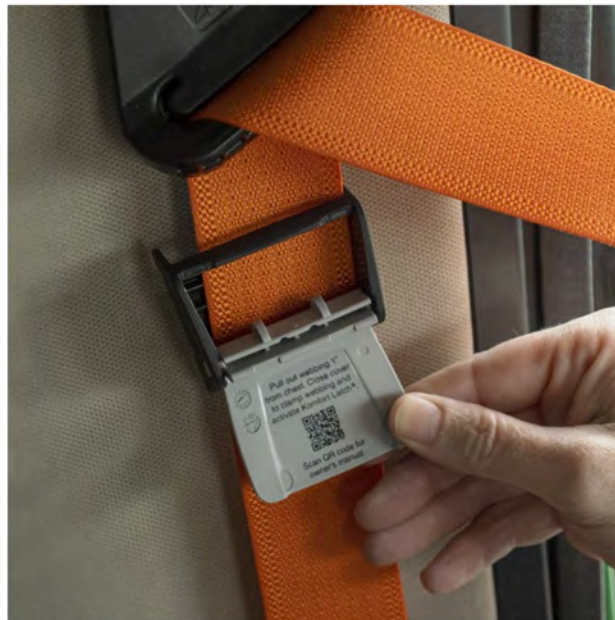

04/27/2023

f910886

Fig 93, Unlocked Komfort Latch

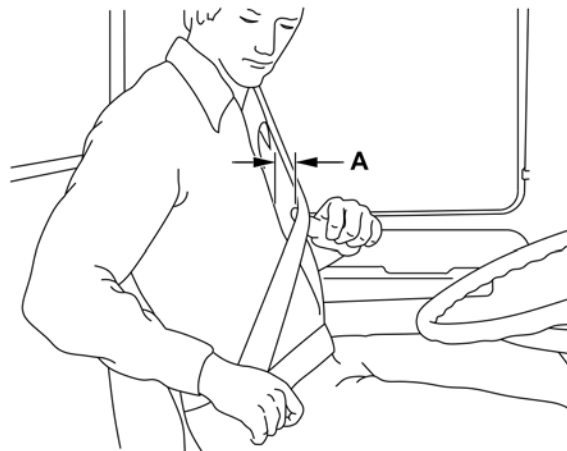

02/03/2017

f910048a

- A. Create no more than 1 inch (2.5 cm) of space between your chest and the strap.

Fig 94, Adjusting Shoulder Harness Clearance for the Komfort Latch



Fig 95, Locked Komfort Latch

Unfastening the Seat Belt

NOTE: Komfort Latches do not need to be manually released in an emergency situation, they release under abnormal conditions.

1. Unbuckle the seat belt.
2. If engaged, release the Komfort Latch by giving the shoulder belt a quick tug, or reach up and pull the Sliding Komfort latch down.
3. Make sure the belt is completely retracted and out of the way before exiting the vehicle.

9.01.06 Steering Wheel Air Bag

Operation



NOTICE:

The air bag module may contain perchlorate material; for information, see www.dtsc.ca.gov/hazardouswaste/perchlorate. **Special handling may apply; follow appropriate rules and regulations when disposing of materials.**

When used with seat belts, the SRS provides additional protection to the driver in severe frontal collisions. Steering wheel air bags are designed to inflate only in severe frontal collisions. The driver and the passenger should always wear seat belts. The steering wheel air bag activates during a collision even if the seat belts are not fastened, but the system is designed to provide protection to the occupant only when the seat belts are fastened.

**WARNING:**

Keep all heavy objects in the cab secured. Do not place objects on the steering wheel or between you and the steering wheel. Any such objects may cause harm during an accident. Keep your hands on the sides and lower portion of the steering wheel. Failure to follow these instructions may result in death or personal injury.

For maximum protection in a collision, always be in a normal seated position with your back against the seat back and your head upright. Fasten your seat belt and ensure that it is properly positioned on your body. Since the air bag inflates with considerable speed and force, a proper seat position helps keep you a safe distance from an inflating air bag.

Inspection and Service

NOTE: Do not attempt to service or modify the air bag system. Unintentional or improper air bag deployment could cause severe bodily injury or death. Contact an authorized Freightliner service facility for all service and maintenance.

The air bag system contains components that use combustible chemicals. Do not cut, drill, braze, solder, weld, strike, or probe the air bag components. Keep all liquids and chemicals away from air bag components.

The surface of the deployed air bag may contain small amounts of sodium hydroxide (which is a by-product of the gas generant combustion) and metallic sodium. Sodium hydroxide may be irritating to the skin and eyes. Immediately wash your hands and exposed skin areas with a mild soap and water. Flush your eyes immediately if exposed to sodium hydroxide.

The operational readiness of the air bag system is indicated by the supplemental restraint system (SRS) error telltale as shown, see Fig.96, [SRS Error Telltale](#). The SRS error telltale illuminates for several seconds when the ignition is turned on, and then it goes off. The telltale remains on if there is a problem with the air bag system. The vehicle should be serviced if the SRS telltale does not illuminate when the ignition is turned on, or if the SRS telltale remains on.



For all service and maintenance, contact an authorized Freightliner service facility.

9.01.07 Passenger Safety Telltales

Indicators (telltales) and Messages

Telltales and messages appear on the driver display. The positions of the telltales vary, but most use standard symbols.

The colors of telltales indicate the hazard level as follows: red (warning), amber (caution), green (normal function), blue (active status), grey (passive status), white (informational).

The colors of messages indicate the hazard level as follows: red (warning), amber (caution), grey (informational).

Telltales for passenger safety related features are listed as shown, see Table.22, [Passenger Safety Telltale Lamps and Messages](#). Every vehicle may not be equipped with every feature.

Passenger Safety Telltale Lamps and Messages				
Telltale	Color	Description	Related Message	
	Red	Unfastened Seat Belt	Indicates the driver's seat belt is unfastened.	When the system detects that the parking brake is off and the driver seat belt is not fastened an audible alert activates.
	Amber	Supplemental Restraint System (SRS) Error	Indicates a malfunction has occurred in the restraint system and restraint system components may be triggered unintentionally or may not deploy as intended during an accident.	If the SRS telltale appears, have the restraint system checked and repaired immediately.
	White	Left-Hand Door Unlatched	Indicates the left-hand door on two door cab is unlatched.	
	White	Right-Hand Door Unlatched	Indicates the right-hand door on two door cab is unlatched.	
	White	Both Doors Unlatched	Indicates both doors on a two door cab are unlatched.	

Table 9, Passenger Safety Telltale Lamps and Messages

10.01 Cab Amenities	132
10.01.01 General Information	132
10.01.02 Driver Display	132
10.01.03 Infotainment Display	132
10.01.04 Power Outlets	132
10.01.05 eStop Button	133
10.01.06 Universal Serial Bus (USB) Ports	133
10.01.07 CB Radio (not shown)	133
10.01.08 Cup Holders	133
10.01.09 Storage (not shown)	133
10.01.10 Keyswitch	133
10.01.11 Adjustable Steering Column	134
10.02 Interior Lighting Controls	135
10.02.01 General Information	135
10.03 Windows	136
10.04 Mirrors	137
10.05 Windshield Wiper and Washer Controls	138
10.05.01 General Information	138
10.05.02 Wiper Controls	139
10.05.03 Wipers and the Rain/Light Sensor	139
10.06 HVAC Controls	140
10.06.01 General Information	140
10.06.02 Fan Speed Switch	140
10.06.03 Air Vent Selection Switch	141
10.06.04 Temperature Control Switch	141
10.06.05 Recirculation Mode	141
10.06.06 Air Conditioning	142

10. Cab Features

10.01 Cab Amenities

10.01.01 General Information

For standard amenities in the eM2 cab, see Fig.97, [Standard and Common Cab Features](#).



- 1. Driver Display
- 2. Infotainment Display
- 3. Power Outlets
- 4. eStop Button

- 5. USB Ports
- 6. Cup Holders
- 7. HVAC Controls

Fig 97, Standard and Common Cab Features

10.01.02 Driver Display

The driver display is used to communicate current information about the vehicle to the driver. See [5.01.01 General Information](#) for complete details.

10.01.03 Infotainment Display

The infotainment displays allows the driver to select settings for connecting a phone, and operating the radio. See [5.01.01 General Information](#) for complete details.

10.01.04 Power Outlets

Two 12V power outlets are located in the dash to power personal devices.

10.01.05 eStop Button

The eStop Button is used to disconnect power from the high voltage batteries. See [20.01 Shutting Down the High-Voltage System](#) for details.

10.01.06 Universal Serial Bus (USB) Ports

Two USB ports are located on the dash to connect and charge different devices.

10.01.07 CB Radio (not shown)

The overhead console is wired to support a CB radio.

10.01.08 Cup Holders

Two cup holders are molded into the center dash.

10.01.09 Storage (not shown)

Storage pockets are molded into the bottom part of the driver and passenger doors. A tablet slot and tray molded are into the top of the dash.

Overhead storage is also available.

10.01.10 Keyswitch

The keyswitch is located on the left-hand dash, below the headlight switch.

The keyswitch has four positions: ACC (accessory), OFF, ON, and START. See Fig. 98, [Keyswitch](#).

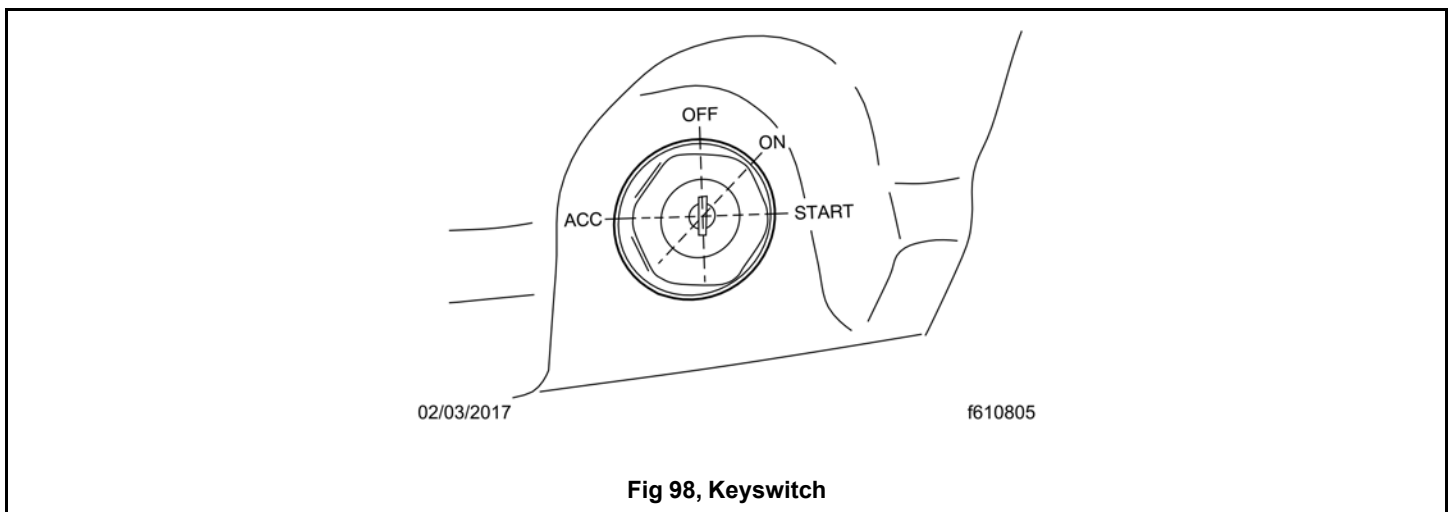

In the OFF position, the keyswitch is vertical. The key can be inserted and removed only in the OFF position.

The following functions are operable when the keyswitch is in the OFF position (regardless of whether a key is inserted):

- low-beam headlights
- tail lights / brake lights
- road lights
- dome light
- clearance / marker lights
- hazard warning lights

- identification lights
- electric horn
- CB radio
- power mirrors
- power receptacles

Turn the key counterclockwise to reach the ACC position. In addition to all the functions that are operable in the OFF position, the following functions are operable when the switch is in the ACC position:

- radio
- blower motors
- heated mirrors
- backup light

Turn the key clockwise past the OFF position to reach the ON position. With the switch in the ON position, all electrical systems become operable and the warning and indicator lamps illuminate. Wait for the ICU self-check to complete before starting the vehicle.

Momentarily turn the key clockwise past the ON position to the START position to activate the powertrain. When the powertrain is active, the ready telltale appears on the driver's display.

10.01.11 Adjustable Steering Column



WARNING:

Make sure that the steering column is locked before driving the vehicle. Never attempt to adjust the column while driving the vehicle. Doing so could cause loss of vehicle control, personal injury, and property damage.

To unlock the steering column to adjust it, pull the steering column locking lever away from the column. As you pull it away it arcs down as shown, see Fig.99, [Unlocking the Steering Column](#).



03/30/2023

f462506

- A. Pull the steering column locking lever away from the column.

Fig 99, Unlocking the Steering Column

With the column unlocked, the steering wheel can be adjusted up-and-down and tilted forward and backward. Once the wheel is in the desired position, lock the position by pushing the lever toward the column until it is parallel to the column and cannot be pushed in further.

10.02 Interior Lighting Controls

10.02.01 General Information

Interior lights include the dome light, dash or reading lights, foot lights, and the dash lighting.

Lamps may be controlled by vehicle inputs, dash-mounted switches, or both.

Dash-mounted switches are backlit to illuminate both the text and icon on the switch. Press the upper half of the switch to turn the desired light(s) on or off. If the lights have a dimming function, holding the switch cycles the light between bright and dim.

Courtesy Lighting

Courtesy lighting consists of a number of lamps that illuminate when a cab door is opened. These lamps include:

- door lamps,
- foot well lamps, and
- cab dome lamp.

The duration of this courtesy lighting can be modified on the infotainment screen under 'Lighting' > 'Interior Lighting' > 'Settings' (gear icon).

Door Lamps

A door lamp is located on the bottom front of each door pocket. The door lamps illuminate when the door is open.

Foot Well Lamps

Amber lamps illuminate both foot wells when the door is open. To manually activate, press the foot-well light switch, as shown, see Fig.100,[Foot Well Lamp Switch](#).

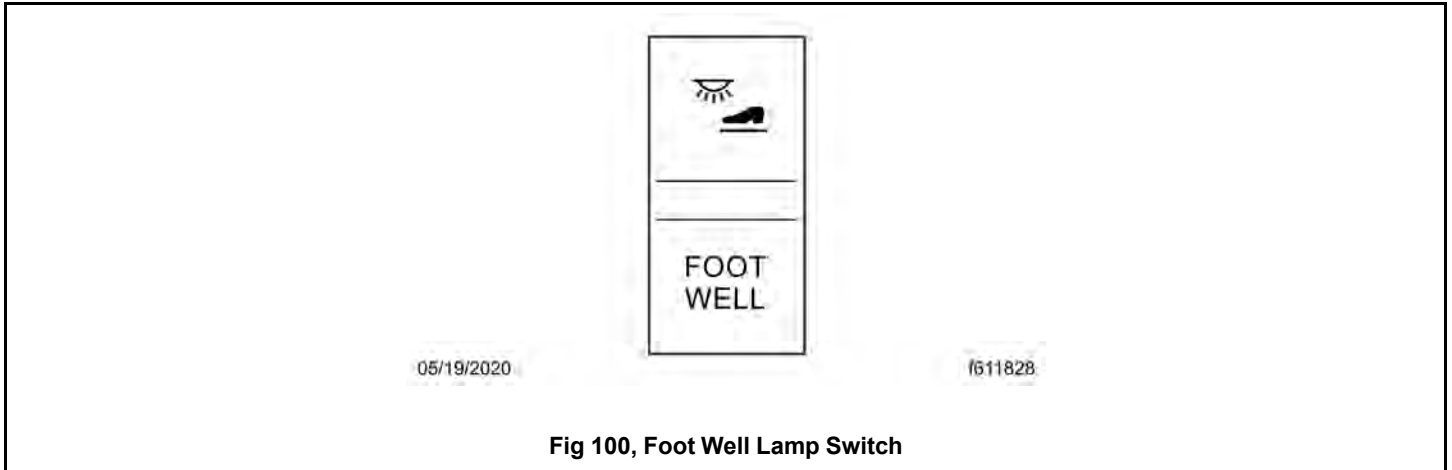

Cab Dome Lamp

This is the lamp located on the highest point of the 'dome' of the cab. It is manually controlled using the dome light switch, as shown, see Fig.101,[Cab Dome Lamp Switch](#). The dome lamp is illuminated when the door is open.

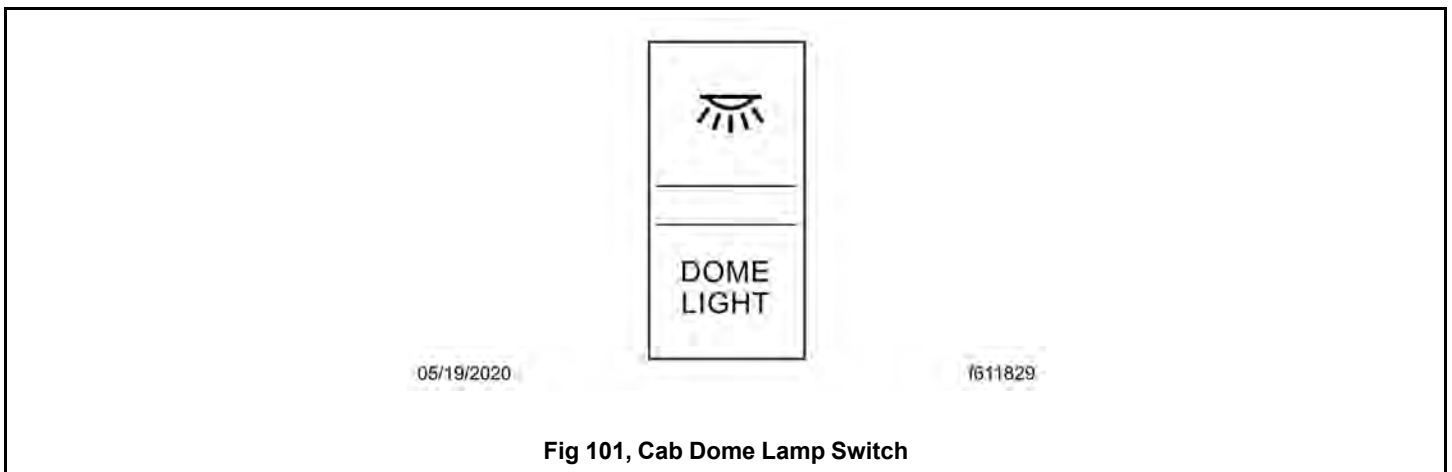

Reading Lamps

These are two reading lamps overhead of the center dash. Press on the lamp covers to turn them on or off.

Premium Lighting

Some vehicles are equipped with premium lighting. Premium lighting gradually illuminates the cab and dash lamps when they are turned on and gradually dims them when they are turned off.

10.03 Windows

Power windows are standard on eM2 vehicles.

The passenger's door has a switch mounted in the top of the door that controls the passenger-side power window. The driver's door has two switches mounted in the top of the door, one to control the driver's window and the other the passenger's window, as shown, see Fig.102,[Door Switches \(driver-side shown\)](#).

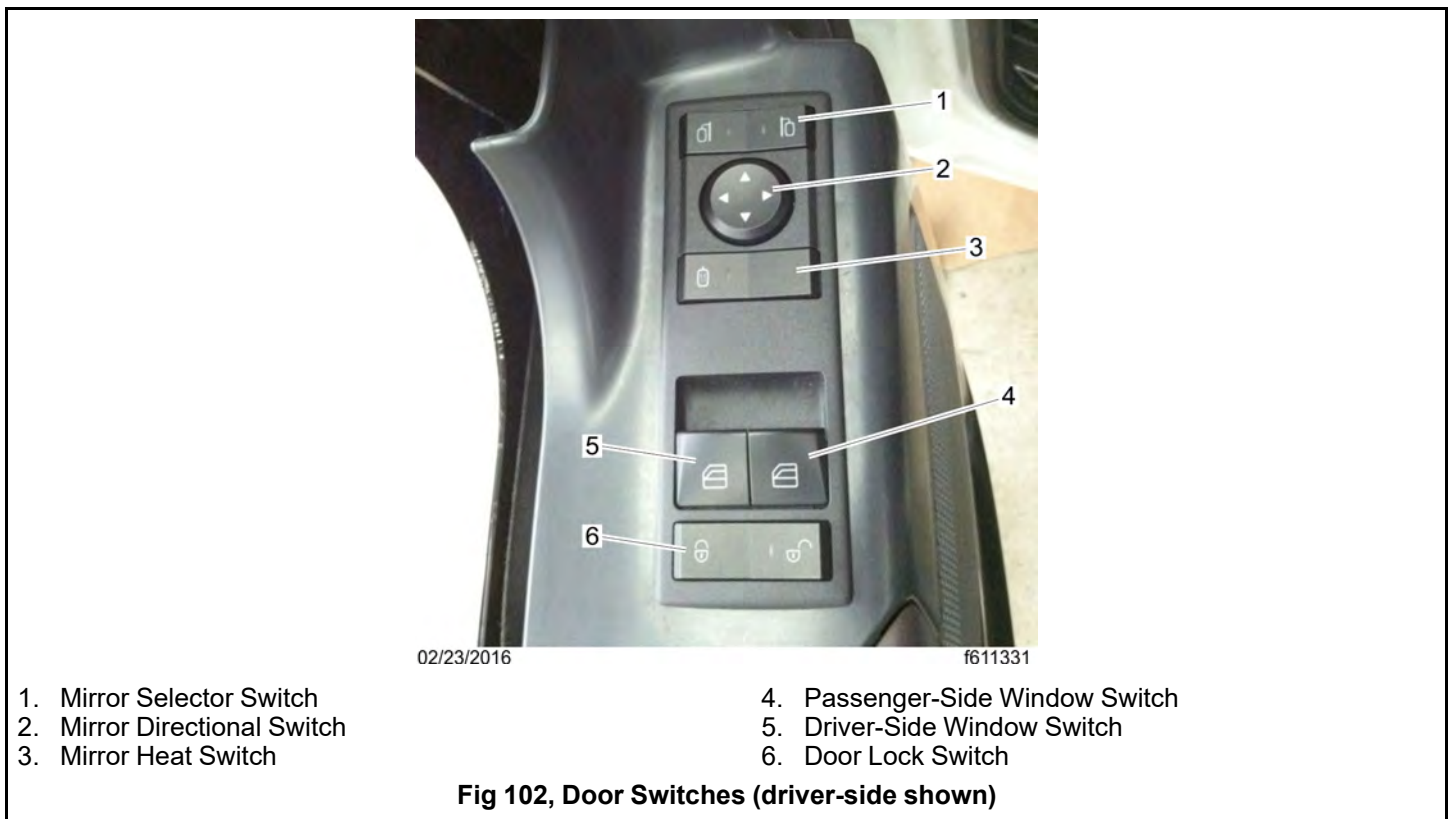

CAUTION:

There is no anti-pinch protection when the window is closing. Be sure to clear all objects from the window before closing.

Press forward on a window switch to lower the window. Hold the switch down in the forward position for approximately one second to activate the express function to have the window roll down after the switch is released. Press the switch in the rearward position to raise the window.

10.04 Mirrors

Power mirrors are standard on eM2 vehicles.

Outside mirrors are mounted on the door frame and are controlled with the driver side door switches as shown, see Fig. 103,[Door Switches \(driver-side shown\)](#).

Adjust the driver side mirror by pressing the mirror selector switch to the left and then using the directional arrow switch to move the mirror. Press the mirror selector switch to the right to use the directional arrow switch to move the passenger side mirror.

To heat the outside door mirrors and clear them of fog, frost, or ice, press the outboard part of the mirror heat switch on the door. An amber indicator light on the mirror heat switch illuminates when the mirror heat is on. The mirror heat automatically

turns off after 20 minutes unless the ambient air temperature is less than 28°F (-2°C), at this temperature it cycles on and off in 20 minute increments.

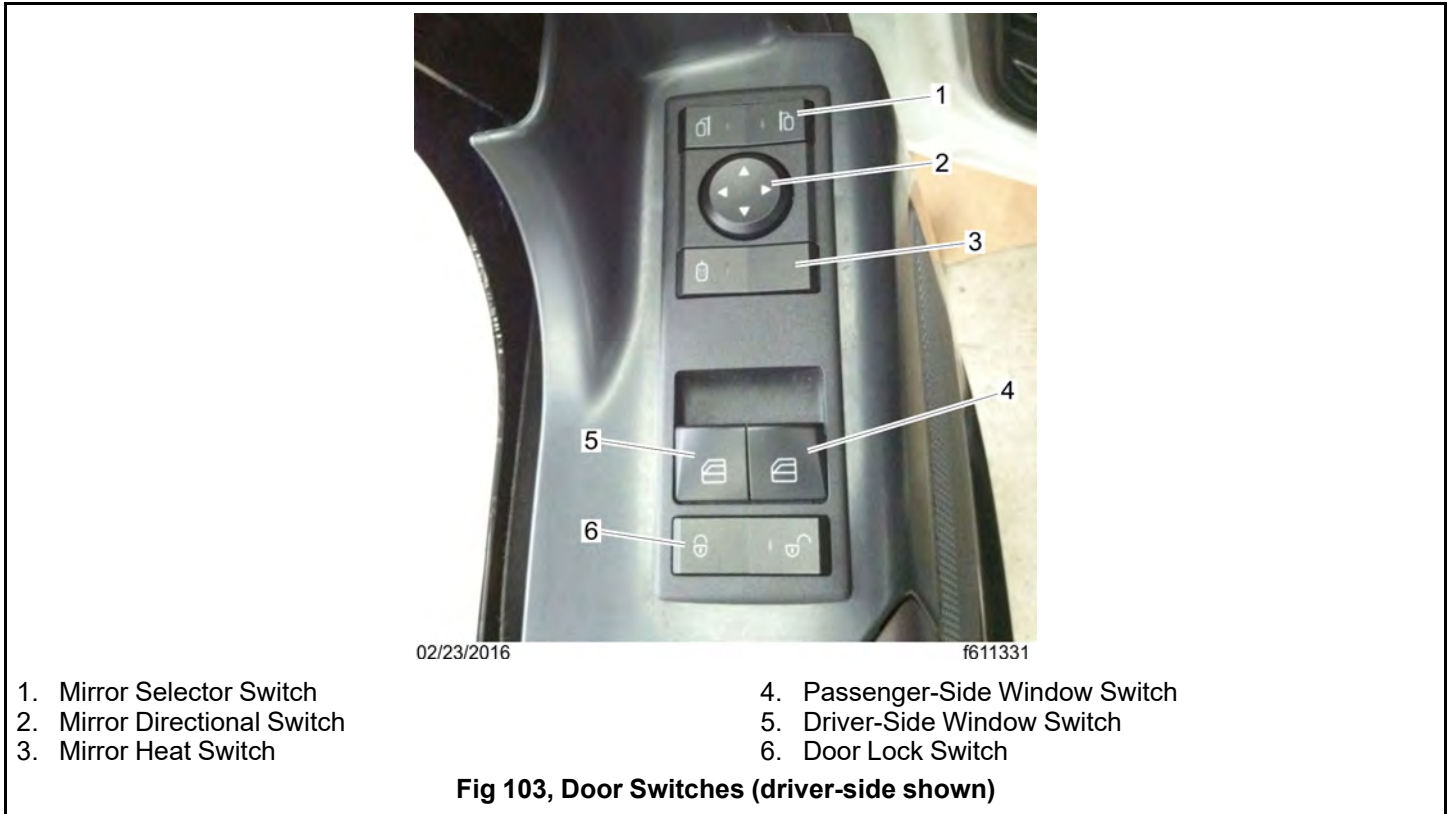

10.05 Windshield Wiper and Washer Controls

10.05.01 General Information



NOTICE:

Do not attempt to manually move the windshield wiper arms. Forcibly moving the wiper arms damages the wiper motor.

The windshield wipers and washer controls are on the left-hand stalk switch on the steering column. See Fig. 104, [Windshield Wiper and Washer Controls](#).

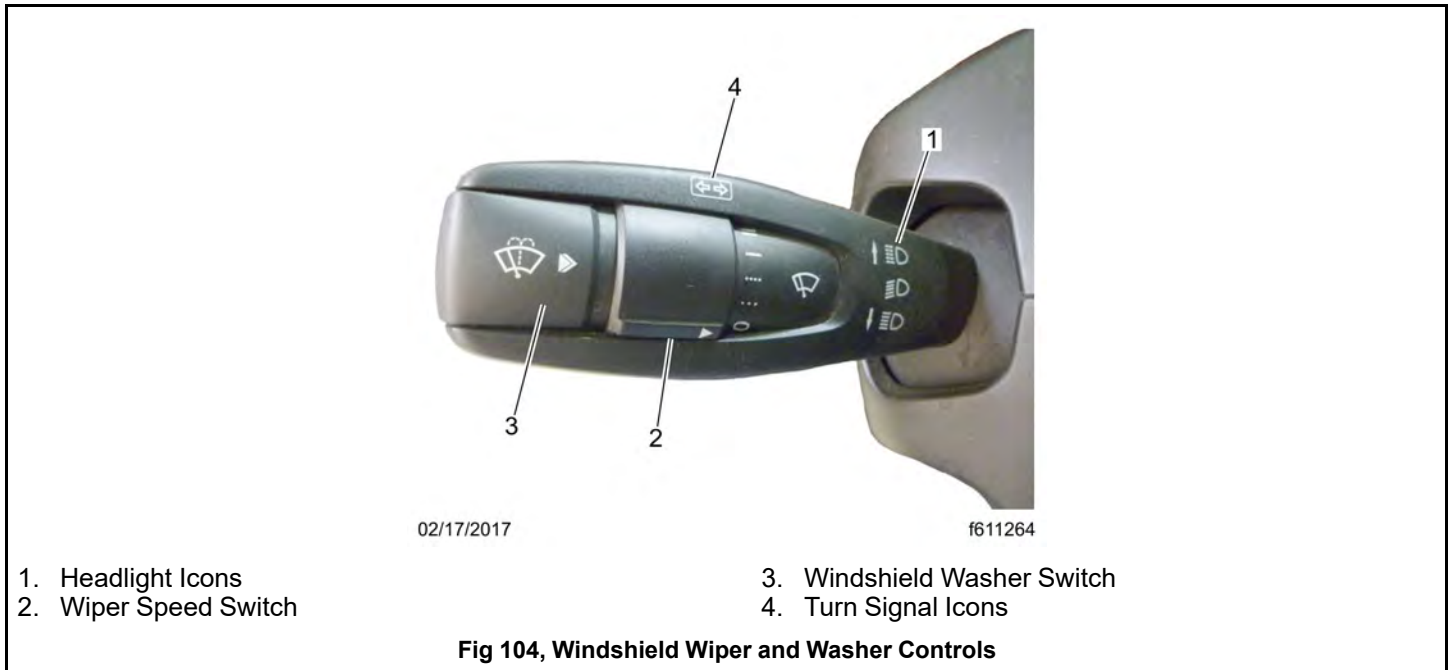

10.05.02 Wiper Controls

The wipers are operated by a rotary switch on the left-hand stalk switch. There are five settings: off, two intermittent speeds, and two continuous speeds. Symbols mark each setting on the dial.

Turn the wipers on by rotating the wiper speed switch up. Continue to rotate the switch to increase the wiper speed through the two intermittent speeds, the continuous low speed, to the continuous high speed. Rotate the switch down to slow the wipers. Rotate the switch all the way down to turn the wipers off.

The default speeds for the two intermittent speeds are six seconds and one second.

The first intermittent speed of six seconds is programmable. It can be reduced to one second or increased up to 25 seconds. To program the interval, rotate the switch from the first intermittent position to the off position, wait for the desired interval between wipes to lapse (between one and 25 seconds), and then move the switch back to the first intermittent position. If the switch is kept in the off position for more than 50 seconds, the interval changes back to the default of 6 seconds.

The second intermittent speed has an interval of one second is not programmable.

NOTE: The eM2 is equipped with a feature that turns on the headlights if the windshield wipers are on, and the vehicle is traveling between 10 and 40 mph (16 to 64 km/h). Cycling the headlight switch turns the headlights off.

10.05.03 Wipers and the Rain/Light Sensor

A rain/light sensor, location as shown, see Fig. 105, [Multipurpose Camera 2 Component Locations](#), is standard equipment. When the sensor detects rain or snow, and the wiper speed switch is set to one of the intermittent settings, the wipers activate to clean the window.

If the vehicle is moving faster than 40 mph (64 km/h) the wiper speed automatically increases and decreases, dependent upon how much moisture builds up on the windshield between wipes.

If the wiper switch is set to a continuous speed (low or high), input from the rain/light sensor is ignored.

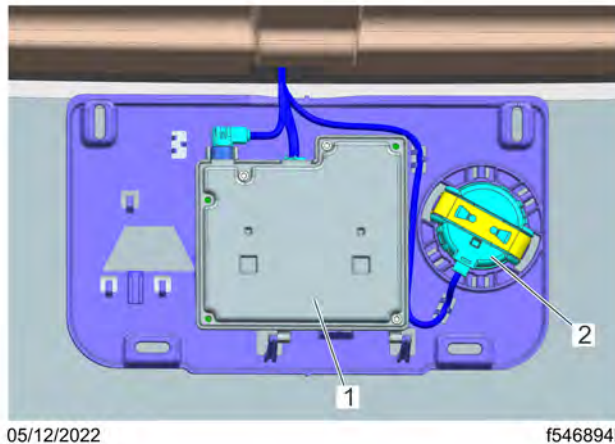

- 1. Multipurpose Camera 2 (MPC2)
- 2. Rain/Light Sensor

Fig 105, Multipurpose Camera 2 Component Locations

The behavior of the wipers based on the rain/light sensor input is independent of the headlamp switch position.

10.06 HVAC Controls

10.06.01 General Information

Controls for the heating, ventilation, and air-conditioning system (HVAC) consist of a fan speed switch, an air vent selection switch, and a temperature control switch. On vehicles with air conditioning, the panel also contains a telltale LED and an air recirculation button as shown, see Fig. 106, [HVAC Climate Control Panel, Standard](#).

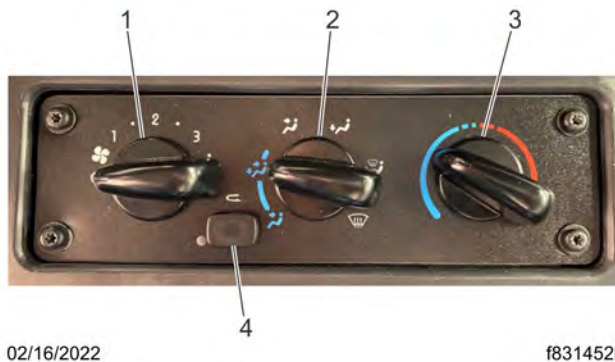

- 1. Fan Speed
- 2. Vent Selection
- 3. Temperature Control
- 4. Air Recirculation

Fig 106, HVAC Climate Control Panel, Standard

10.06.02 Fan Speed Switch

The fan speed switch controls the speed of the fan that forces fresh or recirculated air through the air outlets.

In the default mode fresh, or outside, air circulates through the heating and air conditioning system. If equipped with air conditioning, recirculation mode is available. This limits the amount of outside air entering the cab.

The fan has eight speeds.

10.06.03 Air Vent Selection Switch

The air selection switch allows you to control the flow of air through the face, floor, and defrost vents.

Before using any of the defrost modes, clear the screen at the base of the windshield if snow or ice is present.

With the intermediate modes between each telltale, there are nine modes to choose from on a system without air conditioning, as shown, see Fig. 107, [Air Selection Switch Without Air Conditioning](#), and eleven modes to choose from in a system with air conditioning as shown, see Fig. 108, [Air Selection Switch With Air Conditioning](#).

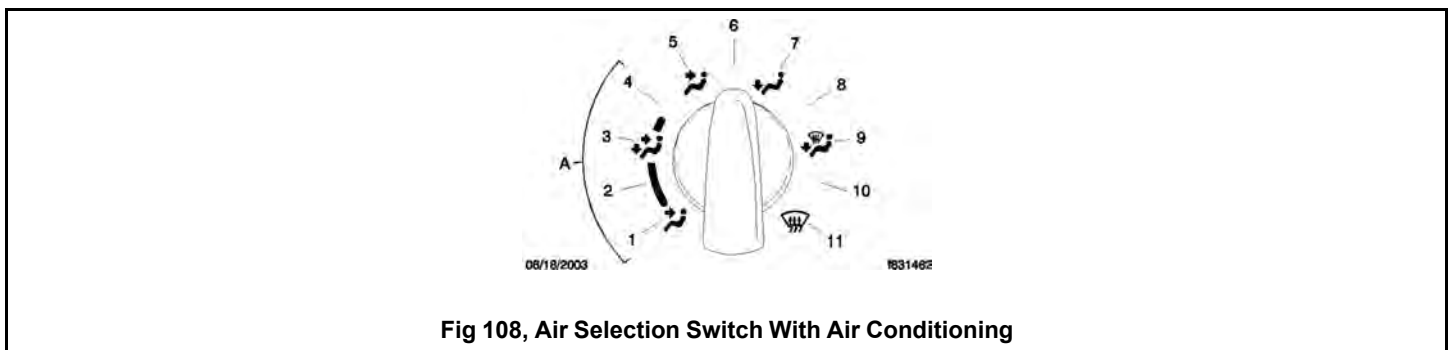
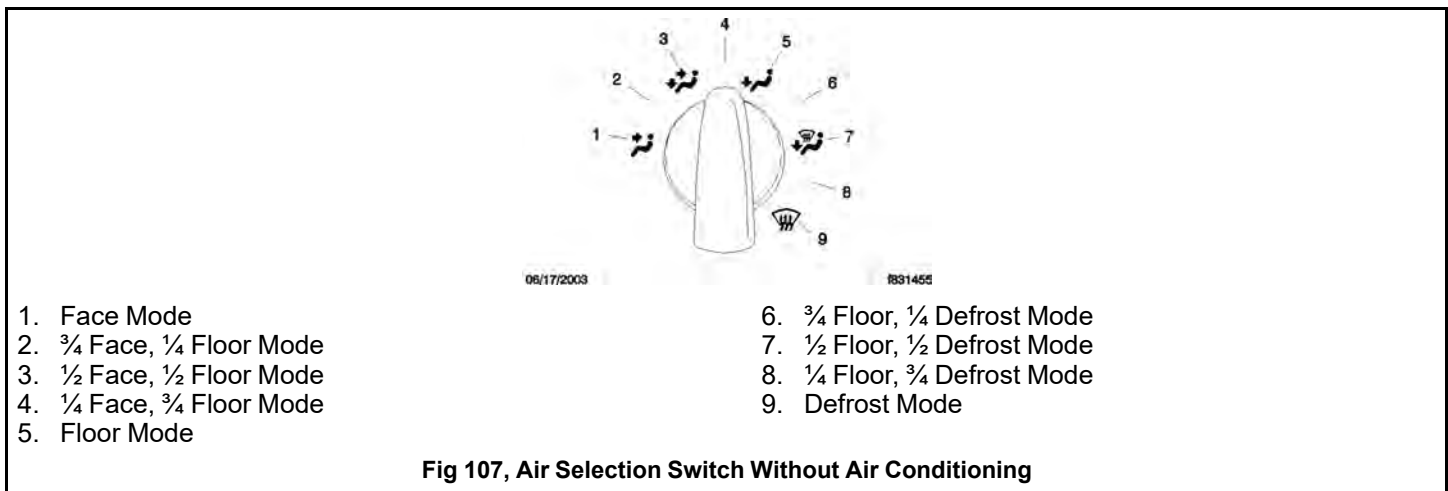

10.06.04 Temperature Control Switch

Turn the switch to the left (counterclockwise) for cool air, or to the right (clockwise) for hot. There are 21 positions on the temperature control switch.

10.06.05 Recirculation Mode

Press the recirculation button to prevent dusty or smoky air from entering the cab or to decrease the time required to cool or heat the cab interior during extreme outside temperature conditions. When recirculation mode is active the LED next to the recirculation button as shown, see Fig. 109, [HVAC Climate Control Panel, Standard](#), illuminates.

To prevent the buildup of odors or oxygen depletion inside the cab, after 20 minutes the system switches from full recirculation mode to partial recirculation mode for five minutes. The system cycles from full to partial recirculation as long as the mode is enabled.

Recirculation mode is not available when the air vent selection is set to partial or full defrost mode.

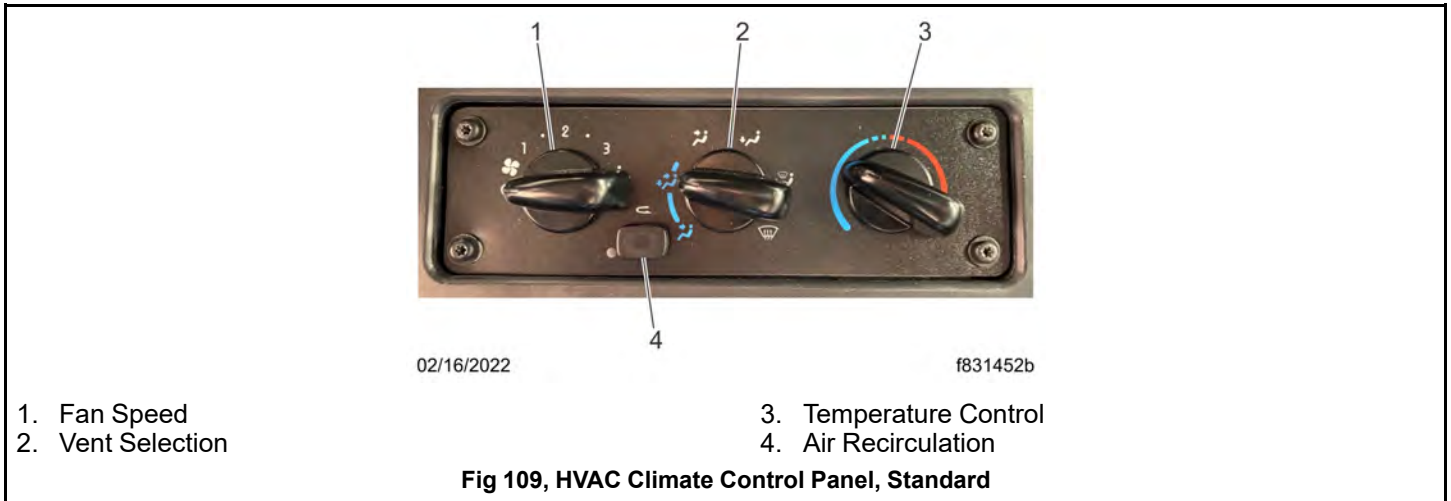

10.06.06 Air Conditioning

The four air conditioning modes are marked in blue on the air vent selection switch.

IMPORTANT: Operate the air conditioner at least five minutes each month, even during cool weather. This helps prevent drying and cracking of the refrigerant compressor seals and reduces the chance of refrigerant leaks in the system.

NOTE: The heating and air conditioning system has a brushless blower motor with a protection or shutdown mode to prevent damage due to overheating and overcurrent conditions. If the brushless blower motor goes into a protection mode, the motor operates at a slower speed. If the overheating or overcurrent condition continues, the motor shuts down and stops completely. The motor resumes normal operation after the motor has cooled or the overcurrent condition has been resolved. It is necessary to cycle the fan switch off, and then on, to reset the motor. If the problem appears repeatedly, take the vehicle to a Freightliner dealer or authorized service outlet for repairs.

11.01 Electric Vehicle Overview	144
11.01.01 General Information.....	144
11.01.02 Electric Vehicle Cooling Components.....	150
11.01.03 Electric Air Compressor	150
11.01.04 The Instrumentation Control Unit (ICU) and Fault Codes	150
11.02 Low-Voltage Battery Disconnect Procedure	151
11.03 Smart Battery Shut-Off Switch	152
11.04 Electric Vehicle Power Distribution	153
11.04.01 General Information.....	153
11.04.02 Cab Electrical and Electronic Components	156
11.05 Powernet Management	157

11. Electrical System

11.01 Electric Vehicle Overview

11.01.01 General Information

**DANGER:**

Service and repair of an electric vehicle should only be performed by technicians that have completed HV3 Daimler Safety Training. To prevent personal injury or death, or damage to the electric system, do not attempt repairs yourself.

**WARNING:**

The strong electromagnetic field generated by the inverter can cause severe personal injury or death to people with active implanted cardiac devices. Individuals with an active implanted cardiac device must stay away from the vicinity of the active equipment.

See Fig. 110, [Class 6 eM2 Electric Vehicle Components Overview](#) for an overview of the Class 6 eM2 electric vehicle components.

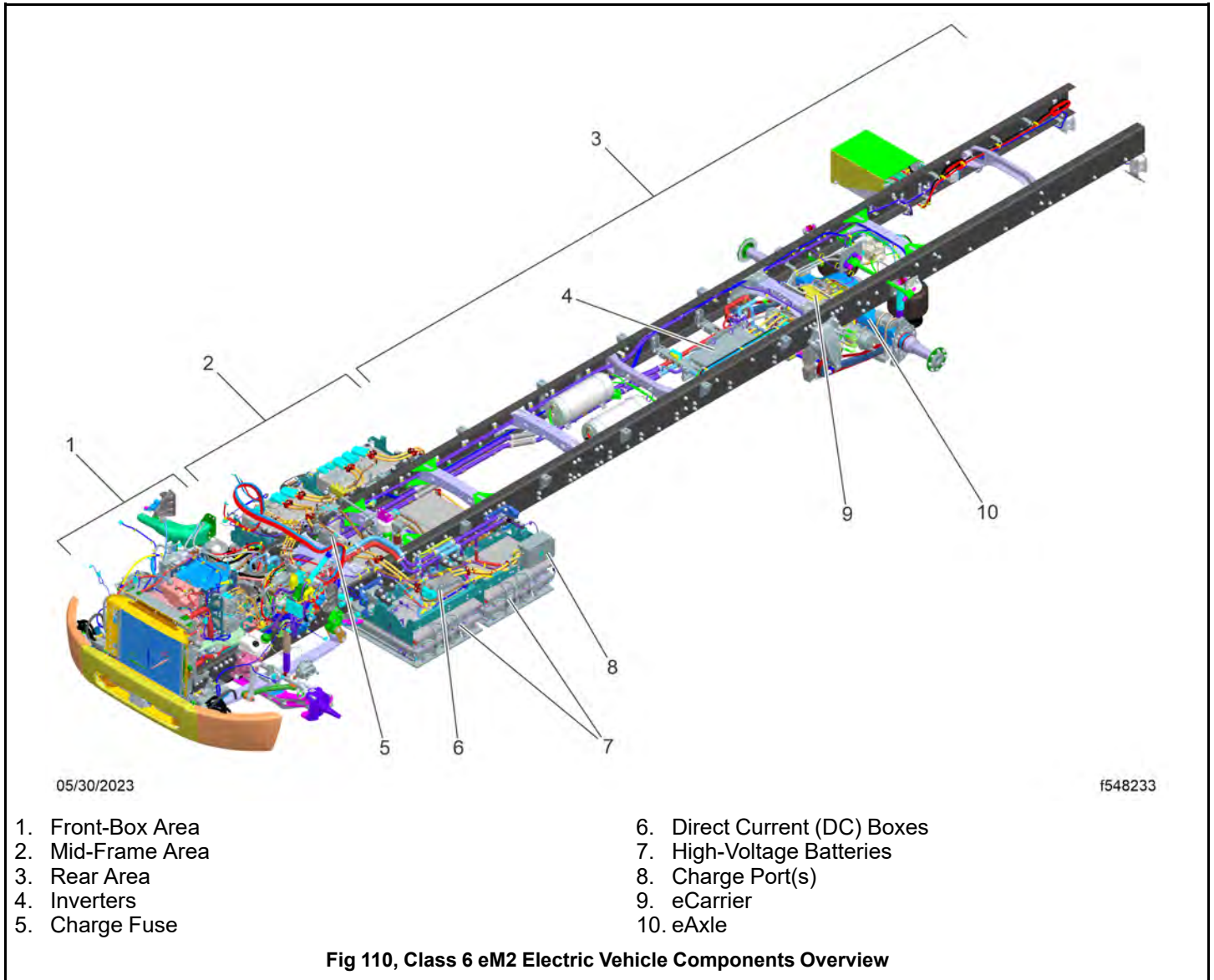

See Fig.111, [Class 7 eM2 Electric Vehicle Components Overview](#) for an overview of the Class 7 eM2 electric vehicle components.

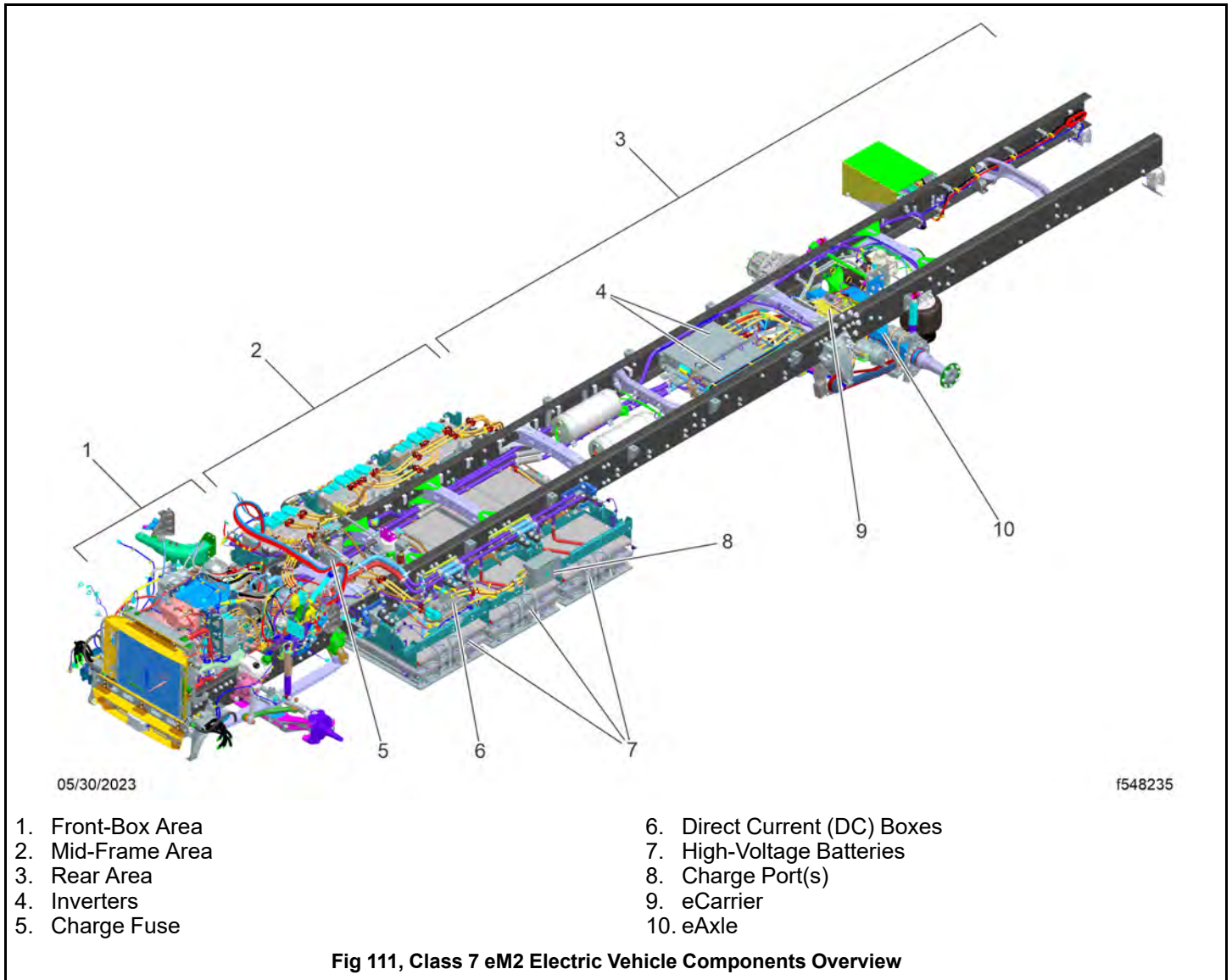

See Fig.112, [High-Voltage Battery](#) for a diagram of a high-voltage battery.

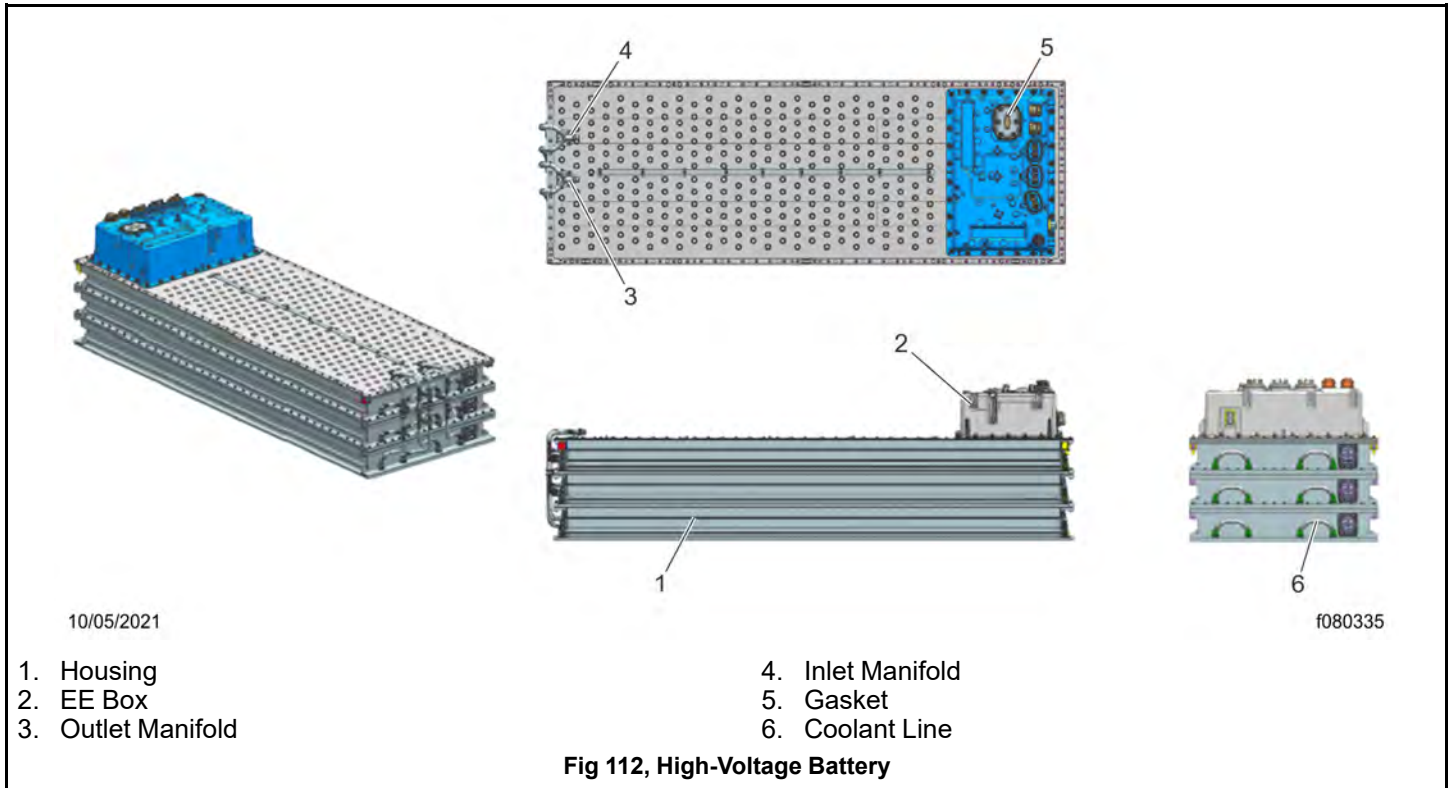

See Fig.113, [High-Voltage Cable](#) for the components of a high-voltage cable.

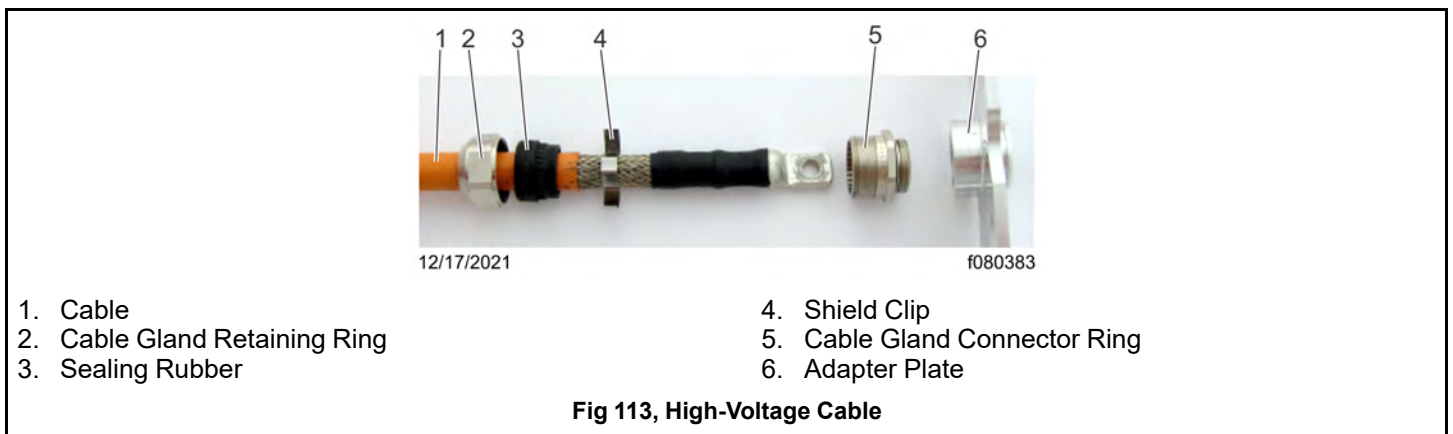

See Fig.114, [High-Voltage Cables Connection - Two Batteries](#) for the connections between two high-voltage batteries.

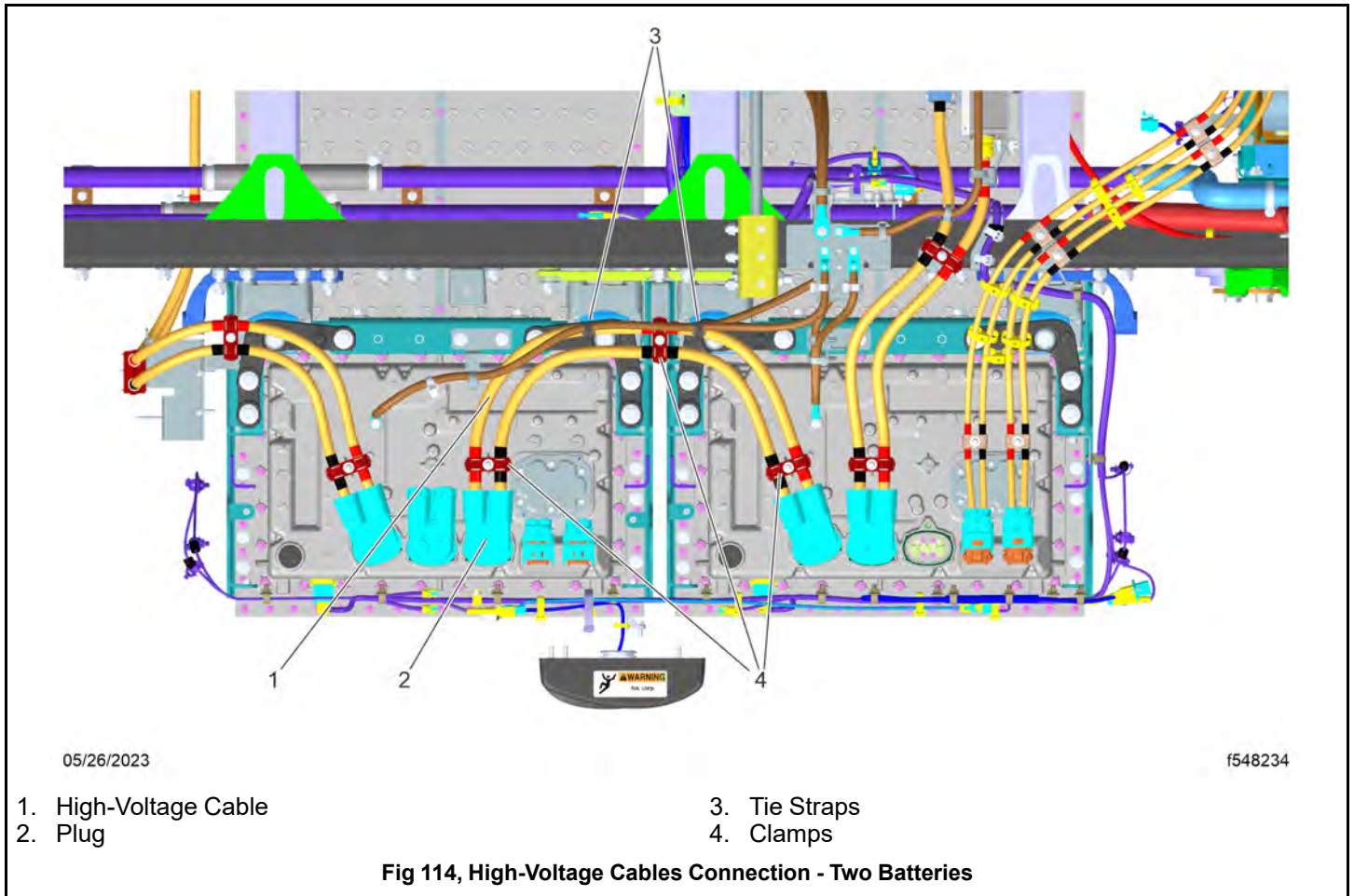

See Fig.115, [High-Voltage Cables Connection - Three Batteries](#) for the connections between three high-voltage batteries.

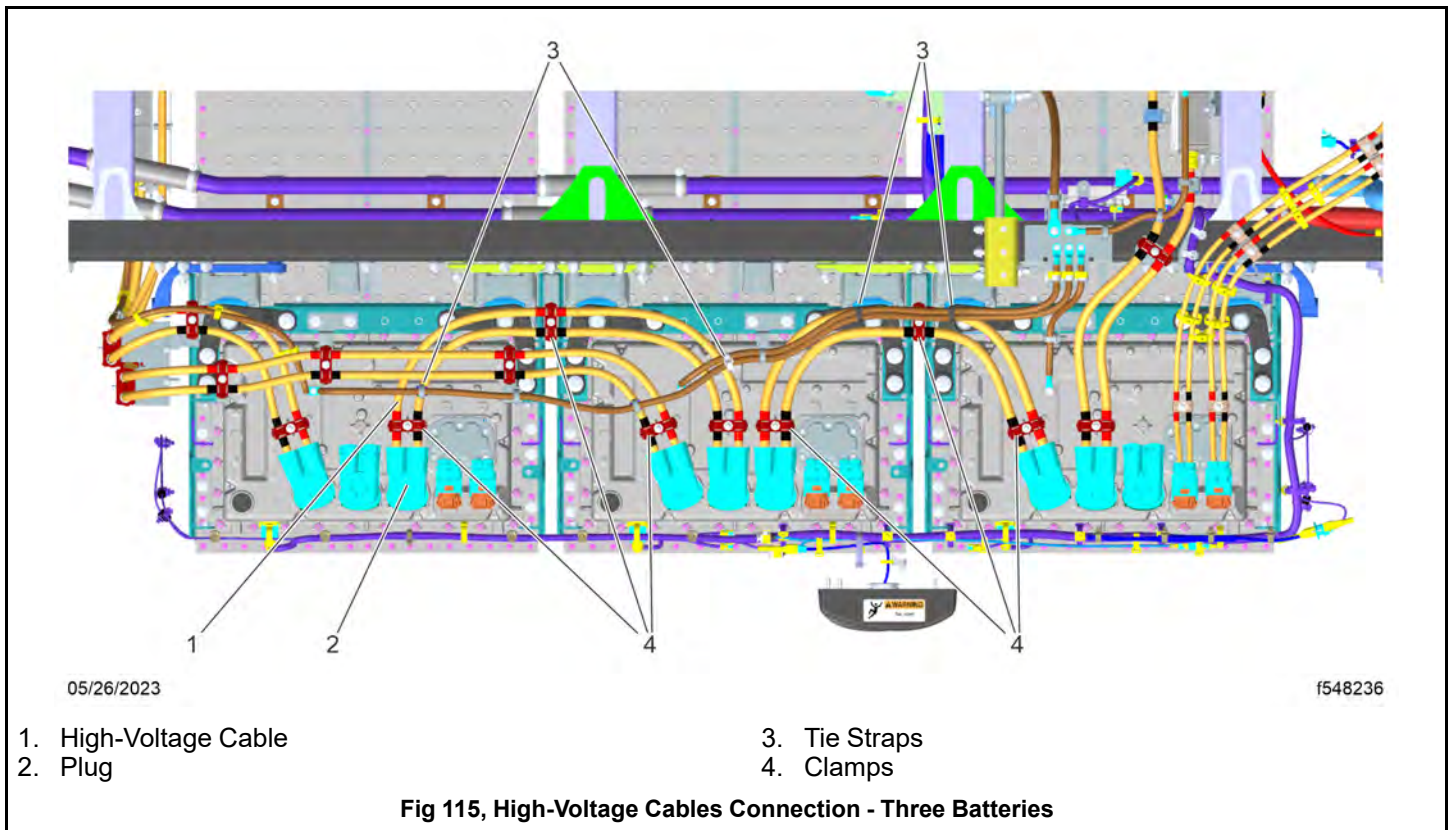

Inverter: An inverter converts power from a direct current (DC) power source (the high-voltage batteries) to the three phase alternating current power needed to drive the motor.

Charge Port(s): A vehicle may be outfitted with one or two charging ports. A single coupler in either inlet may be used to charge a vehicle with dual ports. When both inlets are used, inlet one charges battery one and two and inlet two charges battery three and the power supplied to inlet one is double the power supplied to inlet two.

Charging: The high-voltage batteries can only be charged at DC charging stations meeting the J1772 standards.

Charging Time: When charging with a direct current, the charging time will vary based on the size of the charger and the vehicle limitations. In general, charging a factory-fitted high-voltage battery to 95% of the charge level with a direct current and a charging power of 180kW will take 2-3 hours, depending on battery size.

Electric Vehicle Distribution Module (EVDM): An electrical system on a commercial vehicle usually consists of 12V and/or 24V loads/components that are connected to power distribution modules to get energized and be functional. In these systems, it is desirable to protect 12V and 24V components, outputs/inputs, wires and cables from possible over-current events. The electric vehicle power distribution module (EVDM) is the main component implementing this functionality on an electric vehicle.

The eM2 has a multiplex electrical system. By transmitting multiple electronic messages through the same wire, a multiplex system reduces the number of interconnected wires, allows for more precise control of the electrical system, and makes it easier and quicker to diagnose electrical faults and add optional equipment.

In addition, the wiring harnesses are developed for the maximum number of options, meaning that space for additional wires is available within the wiring harness regardless of the number of optional features on the vehicle. This design provides a cleaner main harness and is meant to eliminate the need for wiring overlays

Electronic control modules (ECUs) coordinate power to outputs such as lighting, displays, gauges, and indicators and control power distribution by monitoring inputs such as sensors and switches.

The ECUs also continuously monitor the status of all input devices and transmit messages over multiple control area networks (CANs), reducing the number of sensors required for operation.

11.01.02 Electric Vehicle Cooling Components

The cooling components are designed to keep the eAxles and high-voltage batteries at their optimum operating temperatures. This results in the most efficient delivery of power and less component stress.

The central components of the cooling system are the radiator assembly, surge tanks, electric refrigerant compressor, heaters, and the electric pumps; the pumps circulate the coolant through all of the connected components.

Radiator: The radiator is placed in front of the front box, connecting to the other cooling components. It helps to eliminate excess heat from the eAxle and high-voltage batteries. It includes a liquid coolant, hoses to circulate the coolant, fans and a thermostat that monitors the coolant temperature.

Surge Tank: The surge tank provides storage space for reserve coolant, expansion space for heated coolant, and de-aeration space. When coolant in the radiator runs low, reserve coolant stored in the surge tank flows from the tank, through the fill hose, to the water pump.

Electric Coolant Pump: An electric coolant pump is powered by the low-voltage system. It pressurizes the coolant to ensure the coolant circulates in the cooling system.

Positive Temperature Coefficient (PTC): The PTC heaters provide efficiency and safety to the electric vehicle heating system. This heater uses a PTC semiconductor as the heating element. The PTC semiconductor drastically increases its electrical resistance at temperatures above a certain level and is able to maintain a constant heating element temperature during load and supply voltage changes. For this reason, the risk of the heating element's overheating or catching fire is minimal, even under unexpected boil-dry conditions due to the loss of hot water. Moreover, the heat generation capacity is nearly constant over a wide range of battery voltage fluctuations.

Chiller: The chiller transfers the thermal energy from the battery coolant loop to the vehicle's refrigerant loop to maintain optimum battery temperatures. The chiller has an electronic expansion valve that regulates the refrigerant flow into the chiller.

Electric Refrigerant Compressor (eRC): The electric refrigerant compressor is the heart of the cooling cycle. The cycle begins when the compressor draws in cool, low-pressure refrigerant gas from indoors. The motor-driven compressor's sole function is to squeeze the refrigerant, raising its temperature and pressure so that it exits the compressor as a hot, high-pressure gas.

3/2 Valve: The three by two valve has one inlet, and two outlet options: A or B. It lets the coolant flow to either the radiator or the active cooling or heating modes.

11.01.03 Electric Air Compressor

The electric air compressor provides and maintains air under pressure to operate devices in the air brake system.

11.01.04 The Instrumentation Control Unit (ICU) and Fault Codes

NOTE: NOTE: Some non-critical faults may be suppressed and will not appear during an instrumentation control unit (ICU) self-check.

The majority of electrical and electronic issues on the vehicle will have an associated fault code, which will be displayed on the ICU.

If the ICU receives active fault codes during the ICU self-check, it displays them one after the other until the parking brake is released or the keyswitch is turned off. Once the parking brake is completely released, the ICU displays alerts until acknowledged. If there are no active faults, the ICU displays the home screen after the self-check completes.

When there is an active vehicle fault code, a popup appears on the ICU message screen. See [Table.23, ICU Electronic Control Unit Acronyms](#) for a list of Acronyms used in fault codes for the ICU.

ICU Electronic Control Unit Acronyms			
ABS	Antilock Brake System	EHPS	Electro-Hydraulic Power Steering
BMS#	Battery Management System There can be up to nine battery management systems: BMS1, BMS2, . . . BMS9.	ETCM	Electronic Transmission Control Module
CGW	Central Gateway	HVCF	Heating/Ventilation/AC Front (HVAC)
DBC	Direct Current Box	ICU	Instrumentation Control Unit
DCL	DC/DC Converter	RDF	Radar Front End
DCMD	Door Control Module, Driver	SAS	Steering Angle Sensor
DCMP	Door Control Module, Passenger	SAM	Signal Detect and Actuation Module
EAPU	Electronic Air Processing Unit	TPMS	Tire Pressure Monitoring System
ECPC	Electronic Common Powertrain Controller	VRDU	Video Radar Decision Unit

Table 10, ICU Electronic Control Unit Acronyms

11.02 Low-Voltage Battery Disconnect Procedure



NOTICE:

The low-voltage batteries on this vehicle are wired in series and in parallel to allow for both 12V and 24V power. Failure to follow the disconnect procedure could cause sparks and issues with the vehicle's electrical system.

1. Remove the three fasteners connecting the negative 12V battery strap, as shown, see Fig. 116, [Low-Voltage Battery Disconnect Process](#), and remove the strap from the vehicle.

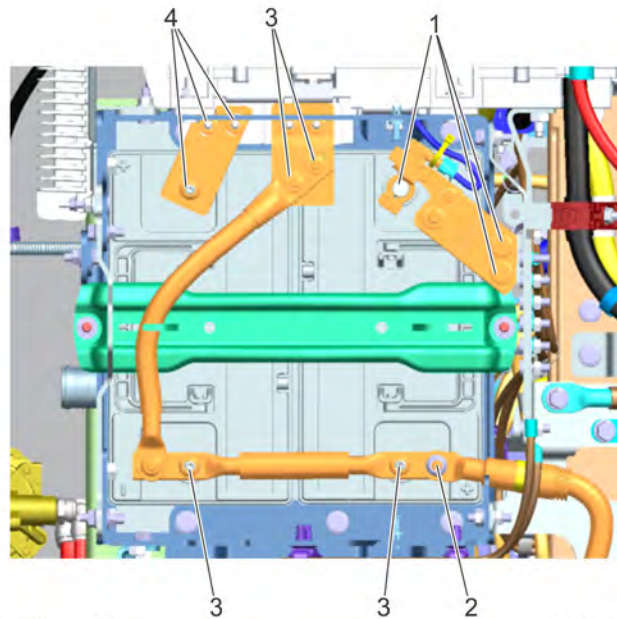

07/02/2022

f080431

1. Remove the negative 12V battery strap.
2. Disconnect the positive BCA cable.
3. Remove the remaining cables.
4. Remove the positive 24V connection plate.

Fig 116, Low-Voltage Battery Disconnect Process

2. Disconnect the positive battery cable access (BCA) cable and move it out of the way.
3. Remove the remaining four fasteners to remove the remaining cables from the batteries. Remove the cables from the vehicle.
4. Remove the three fasteners to remove the positive 24V connection plate.

11.03 Smart Battery Shut-Off Switch



WARNING:

Turning the smart battery shut-off switch to OFF does **not** disconnect power to all electrical components (e.g. the starter and SAM). To work on the vehicle safely, the vehicle must be decommissioned.

IMPORTANT: The keyswitch should be in the off position before turning the smart battery shut-off switch on or off.

The smart battery shut-off switch is located inside the cab on the outboard side of the driver's seat.

The smart battery shut-off switch can be used to open (turn off) or close (turn on) the circuits between the low-voltage battery and the battery cable access box (BCA). Where pressing the eStop button prevents the high-voltage system from turning on, turning off the smart battery shut-off switch disables the low-voltage power that enables cab and chassis functions.

To avoid accidental activation, the smart battery shut-off switch must be pressed and held for two seconds when turning on or off.

A vehicle in daily use would have the smart battery shut-off switch turned ON. When the switch is set to ON, a red LED indicator on the switch illuminates. See Fig. 117, [Smart Battery Shutoff Switch](#). The switch has interlocks to prevent its status from being changed while a vehicle is in operation.



05/30/2023

f548209a

1. Interior Grab Handle
2. Shutoff Switch

Fig 117, Smart Battery Shutoff Switch

Turning the smart battery shut-off switch OFF minimizes the power draw on the battery, preserving battery life and the ability of the vehicle to start after being parked for a number of days.

The smart battery shutoff switch should be set to OFF if the vehicle is going to be parked for more than two days.

11.04 Electric Vehicle Power Distribution

11.04.01 General Information

The electric vehicle power distribution system provides battery power to the electrical and electronic systems.

The following components make up the electrical vehicle power distribution system:

- Battery Cable Access (BCA)
- Electric Vehicle Distribution Module (EVDM)

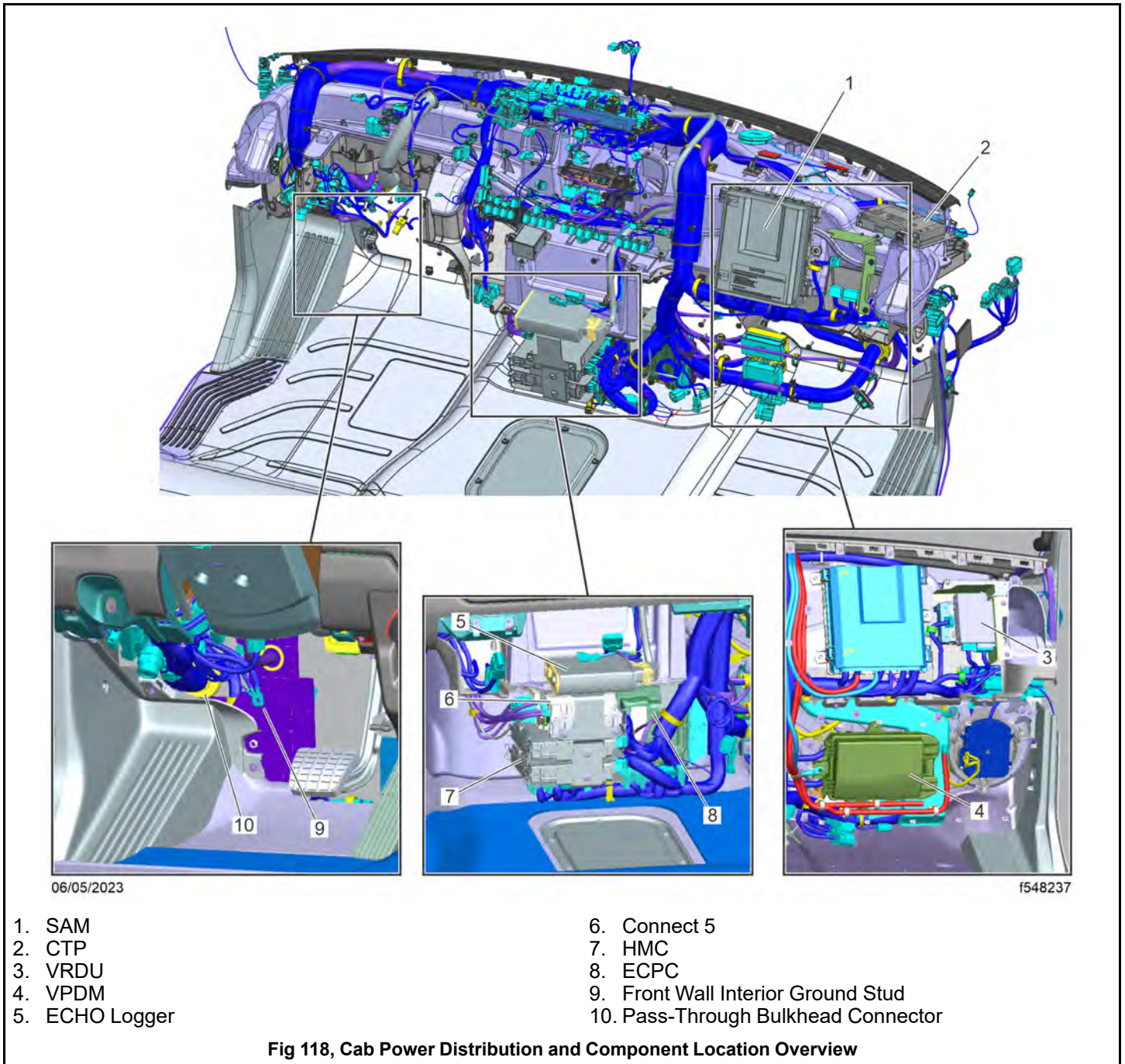

Vehicle power is supplied by the batteries to the battery cable access (BCA) box. The BCA front wall pass-through is the primary interface through which battery power gets transferred from outside the cab to the inside.

On vehicles equipped with an optional high current receptacle and/or optional inverter, the BCA has circuit protection and power cables supplying those devices. Fuse locations depend on the vehicle and are outlined on a label on the BCA cover. For an example see See Fig.119, [Example Fuse Labeling on BCA Cover](#).



Fig 120, EVDM Inside Cover Map of Fuses and Relays

Both the EVDM and the SAM are grounded at the cab-side front wall.

11.04.02 Cab Electrical and Electronic Components

Pass-Through Bulkhead Connector

The pass-through bulkhead connector is where the interior dash harness connects to the exterior chassis harness. This provides a disconnect point for harness service, testing, and replacement. It is located on the driver-side front wall of the vehicle. See Fig.121, [Cab Power Distribution and Component Location Overview](#).

Signal Detect and Actuation Module (SAM)

The signal detect and actuation module (SAM) is the primary module in the electrical system, combining chassis power distribution, cab power distribution, and modular switch functions into a single ECU. The SAM does **not** contain fuses or relays.

The SAM reads input information from sensors, switches, and databus messages, and drives output and controller area network (CAN) messages. The SAM is located behind the passenger side lower dash panel. See Fig. 121, [Cab Power Distribution and Component Location Overview](#).

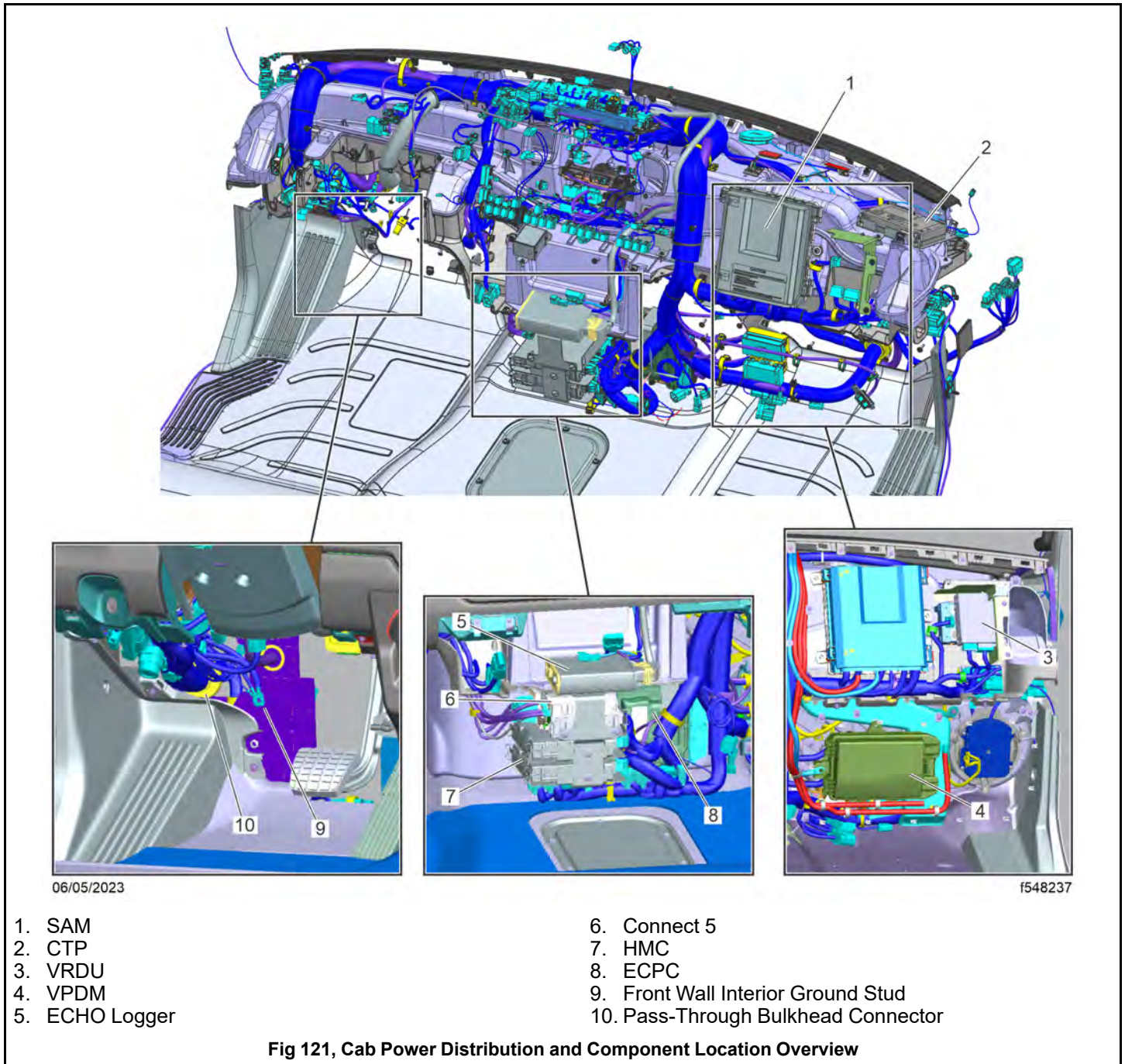

11.05 Powernet Management

The powernet management feature protects the batteries from excessive discharge by disconnecting certain loads—features that draw power—from the battery power supply. This allows the batteries to maintain enough of a charge to restart the vehicle.

Features that draw power are prioritized into different categories:

1. House loads: this includes the majority of dash power outlets.
2. Basic loads: this includes power for fleet management systems and third party telematics as well as critical dash power outlets.

By making noncritical features that draw power temporarily unavailable, powernet management allows the driver to continue using critical features.

Progressive low voltage disconnect (PLVD) is used to implement the powernet management feature.

The front reading lamps are designated as house loads and can be turned back on after being shutdown by PLVD by pressing on the light or light switch.

No alarm sounds before basic loads are turned off.

A time delay is implemented for the shutdown and reactivation of loads to avoid unnecessary cycling when battery voltage is close to shutdown thresholds.

Loads disconnected by the PLVD will reconnect when all of the following conditions are met:

- keyswitch ON;
- batteries reach and maintain 12.3 volts for one minute.

12.01 Charging the Vehicle	161
12.01.01 General Information	161
12.01.02 Charging	161
12.01.03 Troubleshooting When Charging is Interrupted	169
12.01.04 Programming the Vehicle to Charge	169
12.01.05 Preconditioning	171
12.01.06 Charging a Parked Vehicle.....	171
12.01.07 List of Tested Electric Vehicle Chargers	174
12.02 Operating the Vehicle	175
12.02.01 Starting the Vehicle	175
12.02.02 Driving Modes and Energy Efficiency.....	176
12.02.03 Normal Operation.....	177
12.02.04 Predicted Range	178
12.02.05 Cold-Weather Operation.....	179
12.02.06 Hot-Weather Operation	179
12.02.07 Starting the Vehicle After an Extended Shutdown	179
12.03 Vehicle Protection Warnings.....	180
12.03.01 General Information	180
12.03.02 Low State of Charge and Low Range Warnings.....	180
12.03.03 State of Charge and Range Information	180
12.03.04 Low State of Charge Warnings.....	180
12.03.05 Low Range Warnings	182
12.03.06 ePowertrain Telltales	183
12.03.07 eDrive Malfunctions.....	184
12.03.08 eMotor Overspeed Feature	185
12.03.09 High-Voltage Battery Warnings	186
12.03.10 High-Voltage Battery Thermal Event Warning.....	188
12.03.11 Combustible Gas Detection System.....	189
12.04 Vehicle Shutdown.....	189
12.04.01 Standard Shutdown Procedure	189
12.04.02 Emergency Shutdown Procedures	190

12.05 High-Voltage Battery State-of-Health and Deactivation Notifications.....	191
12.06 ePowertrain Telltales	193

12. Vehicle Charging, Operation, and Shutdown

12.01 Charging the Vehicle

12.01.01 General Information

**NOTICE:**

Rapid charging creates higher battery temperatures and decreases battery life. When possible, use low-charging methods to promote battery longevity.

The vehicle must be stationary, the park brake engaged, and the eStop button released for the vehicle to charge. During active charging, if the park brake is released, vehicle movement is detected, or the eStop button is pressed, charging will stop.

The eM2 can charge with the key in either the ON or OFF position. The recommended procedure is to turn the key OFF to shut down the vehicle, then turn the key back to the ON position. Do **not** turn the key to the start position. Plug the charger in and observe the lights on the charger inlet. Once a charge session initiation has been confirmed, turn the key to the OFF position and secure the vehicle.

12.01.02 Charging

1. Park the vehicle and chock the tires.
2. Set the park brake and put the vehicle in neutral.
3. Open the charge port access cover as shown in Fig.122, [Charge Port Access Door](#).



Fig 122, Charge Port Access Door

4. If the inlets are protected with doors, press the latches in the direction of the arrows to open the doors.
If the vehicle has charge port inlet plugs, as shown in Fig. 123, [Charge Port with Plugs](#), remove the plugs.

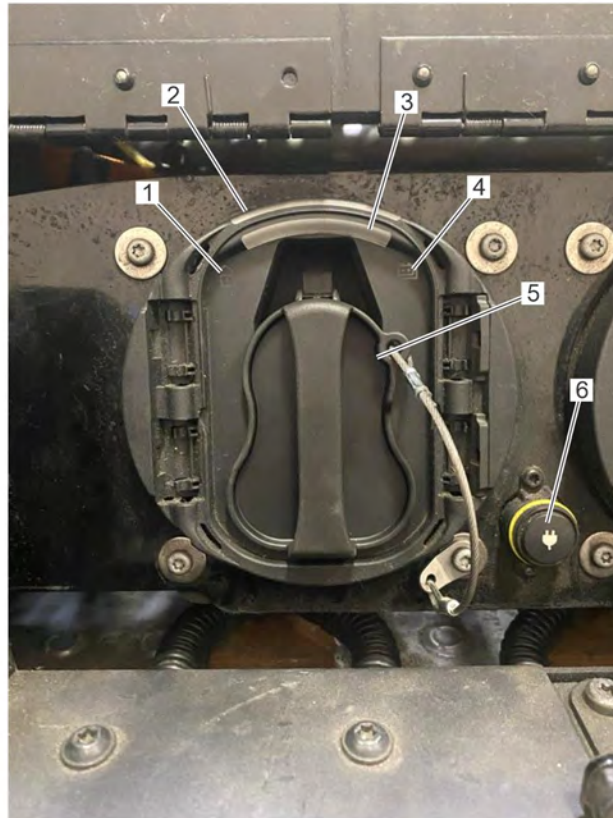

- | | |
|-------------------------|--------------------------|
| 1. Inlet Lock Lamp | 4. Battery Charging Lamp |
| 2. Inlet Status Lamp | 5. Inlet Door Plugs |
| 3. Charging Status Lamp | 6. Stop Charging Button |

Fig 123, Charge Port with Plugs

NOTE: A label outlining the meaning and sequence of the inlet status and charging status lamps is shown in Fig. 125, [Single Port Charging Label](#), and explained further in **Table 1**.

5. Examine the charge port inlets for damage. See Fig. 124, [Damaged Charge Port Inlet Example](#). If damage is present, do NOT attempt to charge the vehicle. Take the vehicle to an authorized Freightliner dealer for repair.

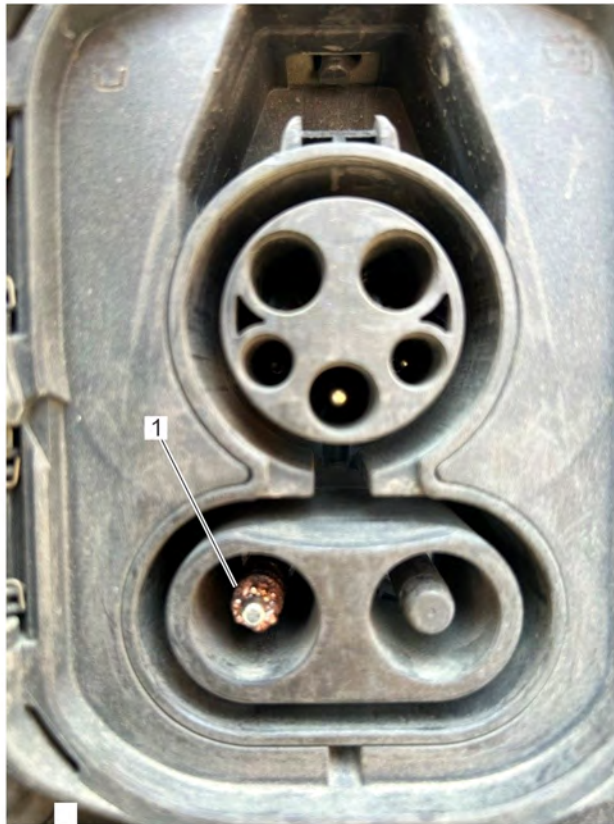

07/23/2025

f548914

1. Example of damage: stripped inlet plug

Fig 124, Damaged Charge Port Inlet Example

6. Verify the inlet status lamp is illuminated white, indicating that it is unlocked.

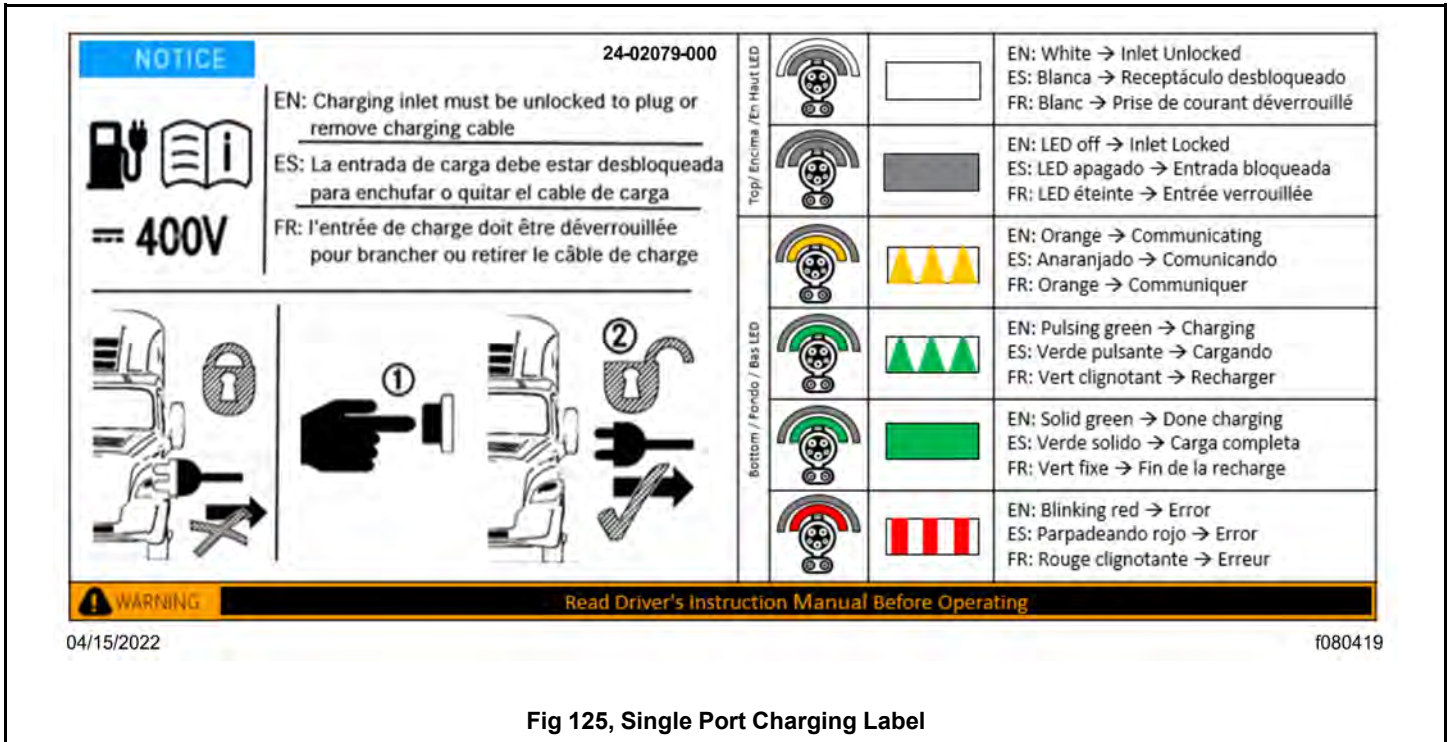

Fig 125, Single Port Charging Label

- Follow directions on the charge dispenser screen about payment or identity verification needed to start the charging process.
- Remove the coupler from the charge dispenser.

If necessary, press the coupler's top latch button, shown in Fig. 126, [Charging Coupler](#), to remove the coupler from the charge dispenser.



03/15/2022

f080406

- 1. Latch Button

Fig 126, Charging Coupler

- 9. Examine the coupler for damage. See Fig. 127, [Damaged Charging Coupler](#). Do not use the coupler if damage is present.



1. Example of damage: stripped coupler plug below broken plastic

Fig 127, Damaged Charging Coupler

10. Plug the coupler into the charge port inlet until fully engaged, indicated by an audible click.

When the coupler engages, the stop charging button illuminates, and the inlet status lamp and the inlet lock lamp go out.

As a connection is being established between the charger and the vehicle, the charging status lamp and the battery charging lamp pulse orange.

When the connection is made and charging of the high-voltage batteries begins, the charging status lamp and the battery charging lamp pulse green.

NOTE: If the coupler is not fully engaged, charging is limited at 1Kw. If this occurs, press the charge stop button, then remove the charge coupler. When the charging station resets, indicating it is available, restart the charging procedure.

11. When the vehicle is finished charging, the high-voltage batteries have either charged to 100 percent or reached the target state of charge, the charging status lamp and battery charging lamp illuminate a steady green.

If charging with the keyswitch OFF, both the charging status and battery charging lamps on the charging port turn off; if charging with the keyswitch ON, both lamps stay on.

The blue charger connected telltale, as shown in Fig.128, [Charger Connected Telltale](#), remains illuminated until the coupler is unplugged from the vehicle inlet.



IMPORTANT: Never release the park brake while the charging coupler is plugged in, or the truck may roll and cause damage to the equipment.

12. When charging is complete, press the coupler's top latch button and remove the charging coupler from the vehicle inlet before releasing the park brake. If the park brake is released prematurely, a warning window appears on the driver display and a continuous chime sounds until the issue is resolved. The dash label, shown in Fig.129, [Dash Label](#), is a reminder to unplug the charging cable before releasing the park brake.

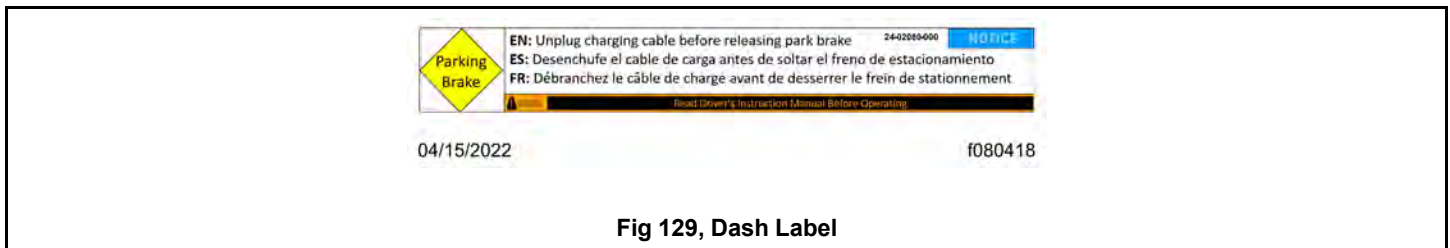

NOTE: The charging process can be stopped at any time in the following ways:

- Press the stop charging button to stop charging and automatically unlock the inlet.
 - Select the stop charging option on the charge dispenser to stop charging and unlock the inlet.
 - Press the coupler's top latch button to stop charging; then press the stop charging button.
 - Lock and unlock the cab door to unlock the inlet.
13. Install the charging inlet plugs if equipped, or latch the inlet doors and close the charge port cover.

Charging Indicator Lamps			
Indicator Lamp	Color	Meaning	Action
Inlet Lock Lamp	White	Unlocked	Plug in the coupler to start charging.
Inlet Lock Lamp	OFF	Locked	Lock and unlock the cab doors to unlock the inlet. OR Let the vehicle continue to charge.
Inlet Lock Lamp	Blinking White	Error	Unplug the coupler and then plug it in.
Stop Charging Button Lamp	White	A charging coupler is connected to the vehicle inlet.	Press to stop charging the vehicle.
Stop Charging Button Lamp	Off	The vehicle's batteries are not being charged.	If a coupler is connected, remove the coupler.
Charging Status Lamp	Pulsing Orange	The charger is communicating with the vehicle.	Wait five seconds.
Charging Status Lamp	Solid Orange	The charger is communicating with the vehicle.	Wait five seconds.
Charging Status Lamp	Pulsing Green	The vehicle is charging.	Allow the vehicle to continue to charge. OR Press the stop charging button.
Charging Status Lamp	Steady Green	The batteries target state of charge has been reached.	Unplug the coupler.
Charging Status Lamp	Blinking Red	Error	Unplug the coupler and then plug it in. If the error persists, have the charger coupler and/or vehicle inlet checked.
Charging Status Lamp	OFF	The vehicle's batteries are not being charged. OR The vehicle is communicating with the charger OR The batteries target state of charge has been reached and the vehicle is asleep.	Plug in the coupler to charge the batteries. OR Wait for charging to start. OR If the batteries are charged, unplug the coupler.
Inlet Status Lamp	White	A charging coupler is not connected to the vehicle.	Plug in a charging coupler.

Table 24, Charging Indicator Lamps

Inlet Status Lamp	OFF	A charging coupler is connected to the vehicle inlet.	Wait for the batteries to charge.
Battery Charging Lamp	Pulsing Orange	The charger is communicating with the vehicle.	Wait five seconds.
Battery Charging Lamp	Pulsing Green	The vehicle is charging.	Wait for the batteries to charge. OR Press the stop charging button.
Battery Charging Lamp	Steady Green	The batteries target state of charge has been reached.	Unplug the charging coupler.
Battery Charging Lamp	OFF	A charging coupler is not connected to the vehicle. OR The batteries target state of charge has been reached.	If plugged in, unplug the charging coupler.

Table 11, Charging Indicator Lamps

12.01.03 Troubleshooting When Charging is Interrupted

1. Verify the eStop button is released, the park brake is set, and that the vehicle is stationary.
2. Verify a target state of charge has been set and has not been reached.
3. Unplug the coupler from the vehicle inlet and plug it in again.

12.01.04 Programming the Vehicle to Charge

NOTE: Keeping a high-voltage lithium battery fully charged and deeply discharging a battery shortens battery life.

In general, a battery lasts longest when kept between a 15 percent and 85 percent state of charge.

NOTE: The vehicle does not have to be connected to a charger to set up charging limits or schedule departure times.

1. On the infotainment screen, select 'Settings' or the gear icon.
2. Select 'Charge Battery.'

The 'Charge Battery' menu, as shown, see Fig.130, [Charge Battery Screen](#).contains two options:

- 'Departure time': Setting a departure time causes the vehicle to draw power at a rate that results in the batteries reaching their target charge by the departure time and activates the preconditioning feature.
When no departure time is set, the vehicle draws the maximum power available until the target state of charge is reached. In this scenario, the time displayed represents when the target state of charge will be reached.
- 'Charging limit': This sets a target state of charge for the high-voltage batteries.

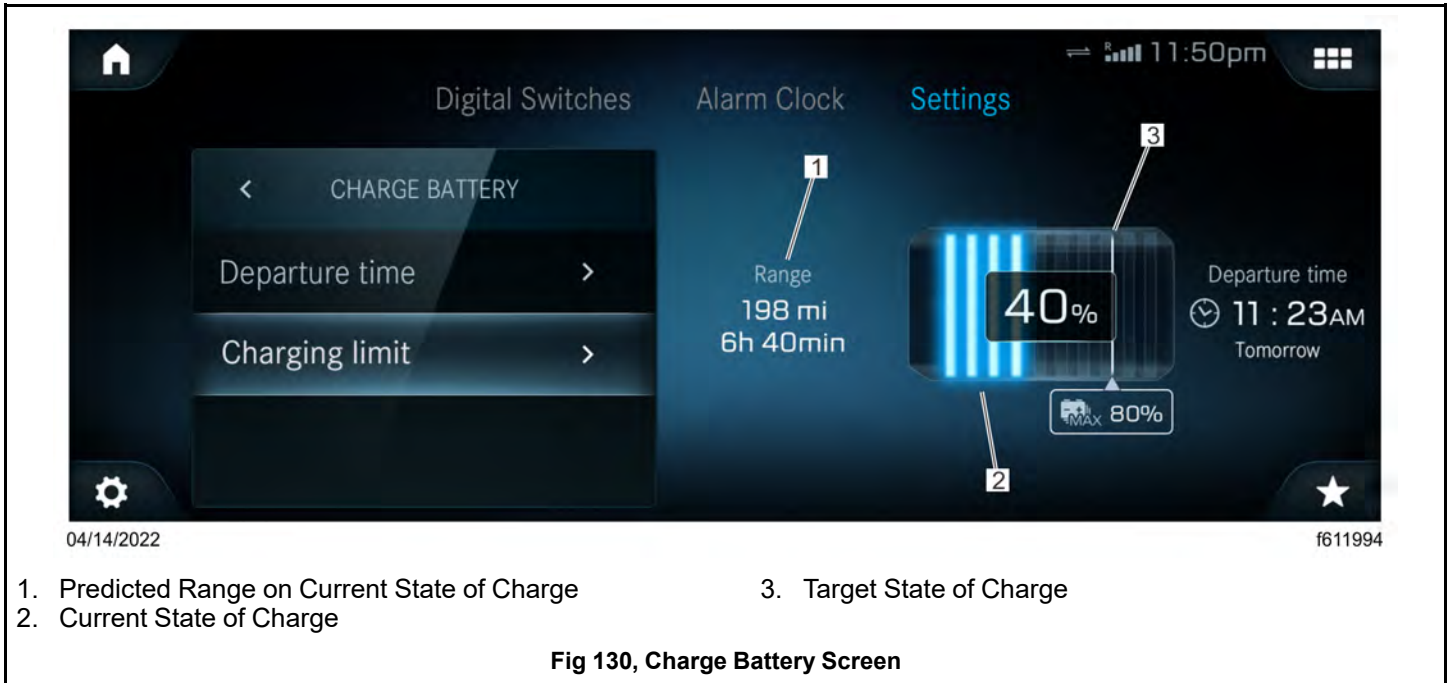

3. Choose 'Departure time' and enter the planned departure time. As shown, see Fig. 131, [Preconditioning Menu Options](#). the scheduled departure time can be set to repeat over multiple days. A desired cabin temperature for the departure time can also be specified.

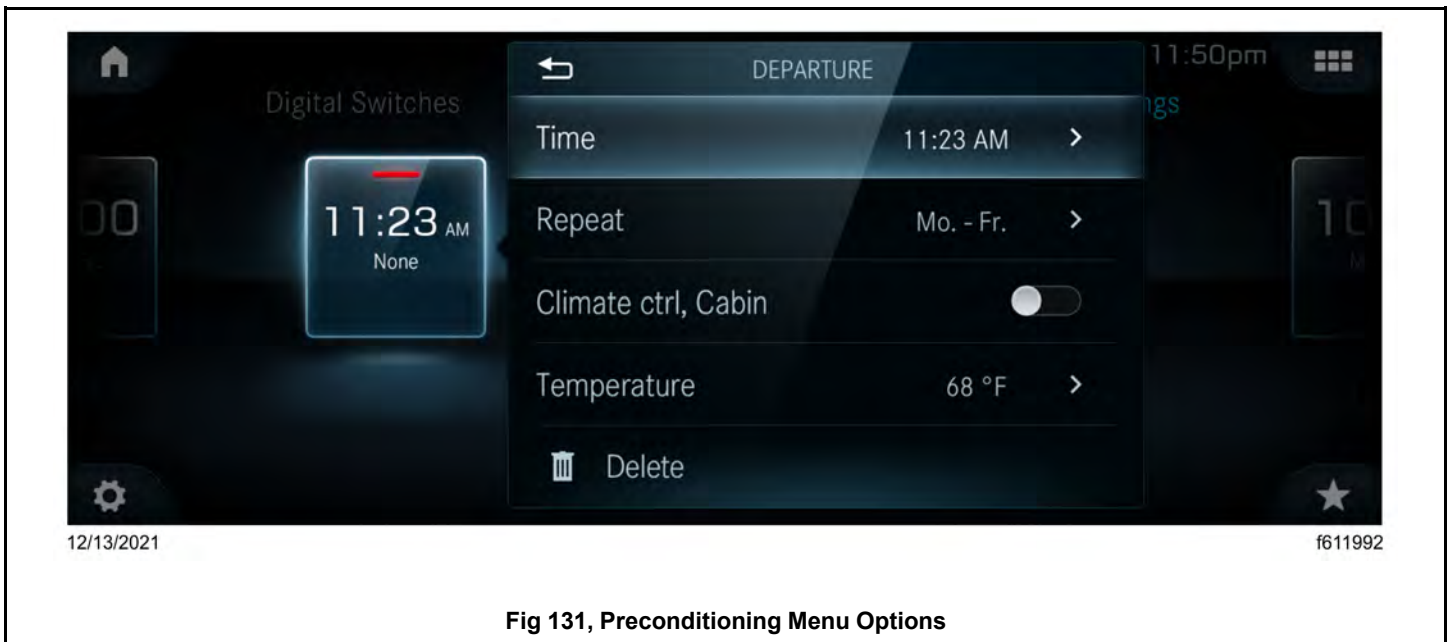

4. Select the back arrow to return to the 'Charge Battery' screen.

NOTE: The lowest accepted charge limit is 50 percent.

5. Select 'Charging Limit.'

When on the screen as shown, see Fig.132, [Charging Limit Screen](#). appears, drag the circle on the percentage bar to set the desired charging limit. This changes the maximum charging limit on the battery icon.

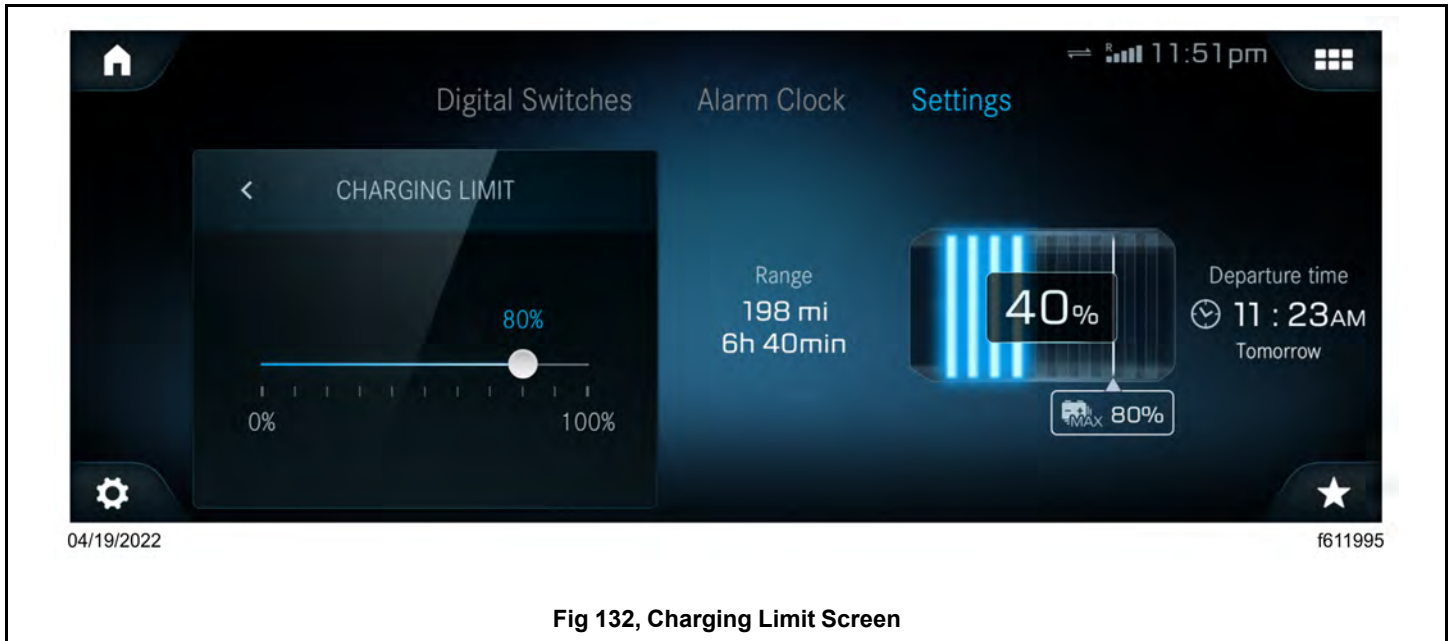

Fig 132, Charging Limit Screen

12.01.05 Preconditioning

The vehicle must be plugged into a charger to activate preconditioning. Preconditioning activates the vehicle's thermal management system to heat or cool the high-voltage batteries, eDrive, and eAxles to bring them to operating temperature by the scheduled departure time. This can reduce the initial on-road power draw from the vehicle's batteries during very hot or cold weather, increasing the predicted range on that charge.

If cab climate control is activated when scheduling a departure time, preconditioning activates the HVAC system to bring the cab to the desired temperature by the scheduled departure time.

If the scheduled departure time passes and the vehicle remains connected to the charger, preconditioning keeps the batteries, eDrive, eAxles, and cab at the desired temperature for a set amount of time.

Preconditioning deactivates if the charging cable is unplugged, the key switch is activated, or an HVAC setting is manually changed.

12.01.06 Charging a Parked Vehicle

When a vehicle is parked and disconnected from a charger, make sure to turn off the cab load disconnect switch located inside the cab, to the rear of the driver seat on the door side, as shown, see Fig.133, [Cab Load Disconnect Switch](#)

NOTE: The cab load disconnect switch must be depressed for at least one second to respond. Momentarily pressing the switch will not activate it; this is to prevent accidental pressing of the switch. When the switch is on, the LED illuminates.



05/30/2023

f548209a

Fig 133, Cab Load Disconnect Switch

When a vehicle is plugged into a charger and will remain plugged in until the next time it is driven, select 'Departure time' under the 'CHARGE BATTERY' settings menu to set the anticipated start of the next shift. See Fig.

135, [Charge Battery Screen](#) and see Fig. 136, [Preconditioning Menu Options](#). Setting departure time will allow the truck to keep high voltage on and maintain the LV batteries for up to 48 hours.

If a truck will be parked for an extended period (longer than 3 days) without being driven, attach a trickle charger to the 12V jump start posts, located under the hood on the passenger side, as shown, see Fig.

134, [Positive and Negative Posts on the Electric Vehicle Distribution Module \(EVDM\)](#)

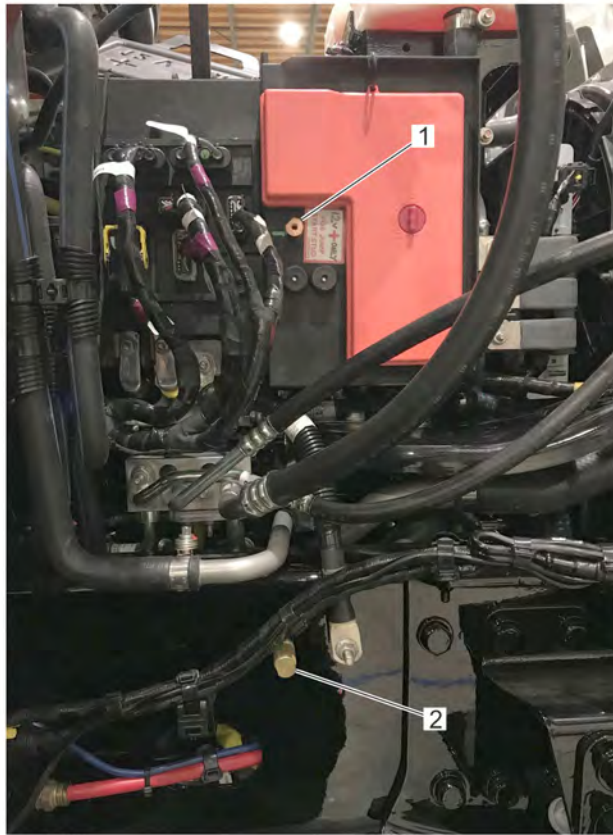

11/18/2021

f547684

Fig 134, Positive and Negative Posts on the Electric Vehicle Distribution Module (EVDM)

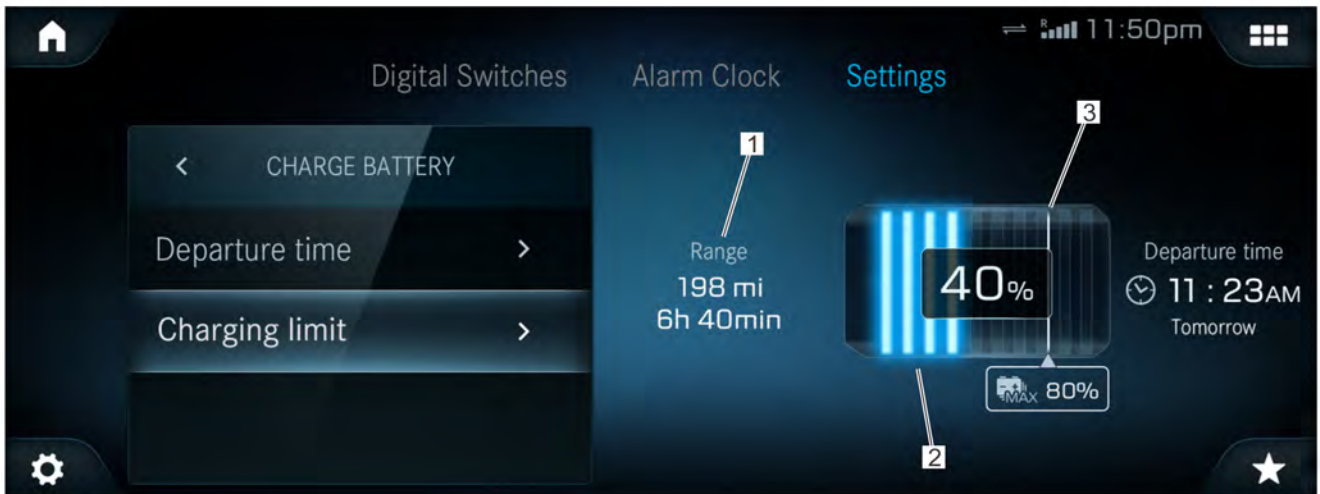

04/14/2022

f611994

- 1. Predicted Range on Current State of Charge
- 2. Current State of Charge

- 3. Target State of Charge

Fig 135, Charge Battery Screen

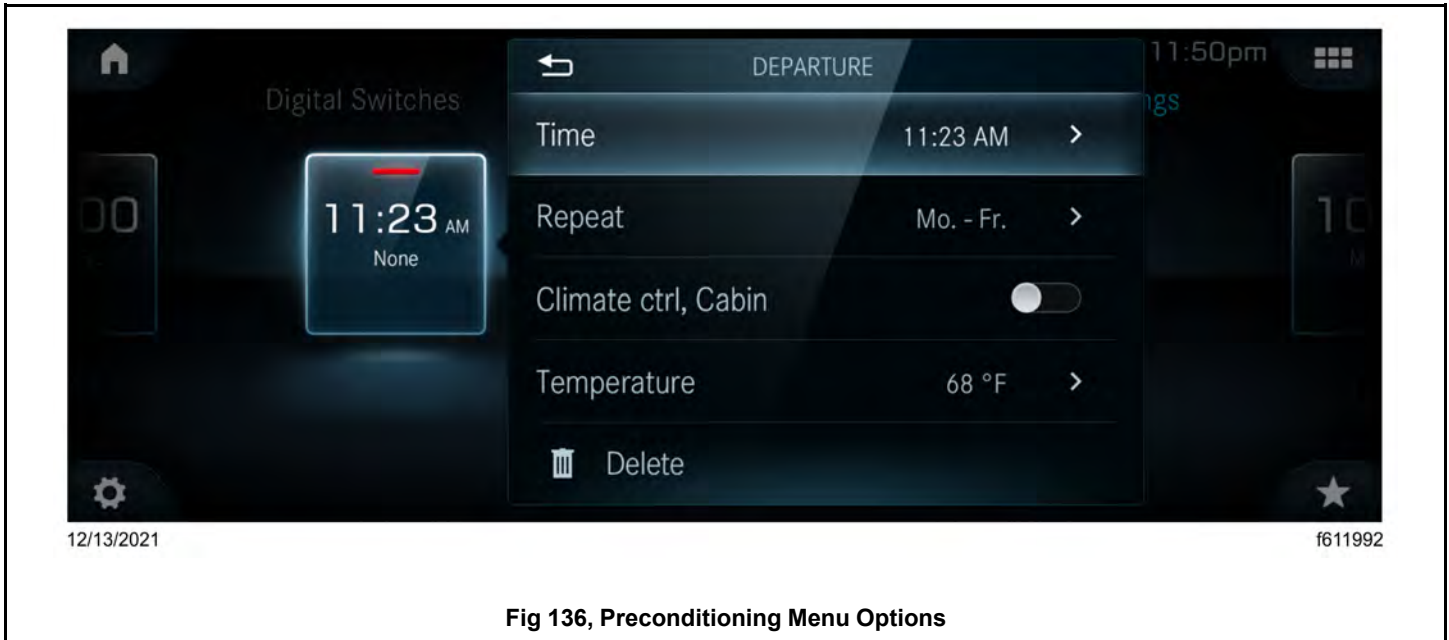

Fig 136, Preconditioning Menu Options

12.01.07 List of Tested Electric Vehicle Chargers

See the table for a list of Electrical Vehicle Supply Equipment (EVSE), commonly known as electric vehicle chargers, that have been tested with the Freightliner eM2 and eCascadia. This testing is to confirm performance with charging operation and major feature functionality.

NOTE: Please ensure that the vehicle's software is the most up-to-date version.

EVSE Make	EVSE Model	EVSE Type	Tested on a Single Charger	Tested with Detroit Connect
Detroit eFill (Power Electronics)	NB240	All-in-one	Yes	Yes
Alpitronic	Hypercharger 400kW	All-in-one	Yes	Yes
ABB	Terra-184	All-in-one	Yes	Yes
ABB	Single-phase Wallbox	All-in-one	Yes	Yes
ChargePoint	ExpressPlus	Distributed	Yes	No
Charge Point	CPE250	All-in-one	Yes	No
Kempower	T800	All-in-one; Movable shop charger	Yes	No
Signet	175kW	Distributed	No	Yes

Table 12, Recommended EVSE List

NOTE: All testing was performed with the latest charger software at the time of installation at DTNA's testing facility in Portland, OR. DTNA does not guarantee full feature functionality on future charger software releases beyond that testing at our facilities. Please contact the call center to confirm software versions if features do not function as expected.

12.02 Operating the Vehicle

12.02.01 Starting the Vehicle

NOTE: Before operating the vehicle, read **Chapter 3, Instruments**, and **Chapter 4, Driver Controls**.

1. If connected to the charging coupler, leave the parking brake set, and unplug the charging coupler from the vehicle inlet.
2. Complete the applicable pre-trip inspections and maintenance procedures in **Chapter 17**.
3. Use the direction switch on the right-hand stalk switch to put the vehicle in neutral, as shown, see Fig. 137, [Right-Hand Stalk Switch](#)

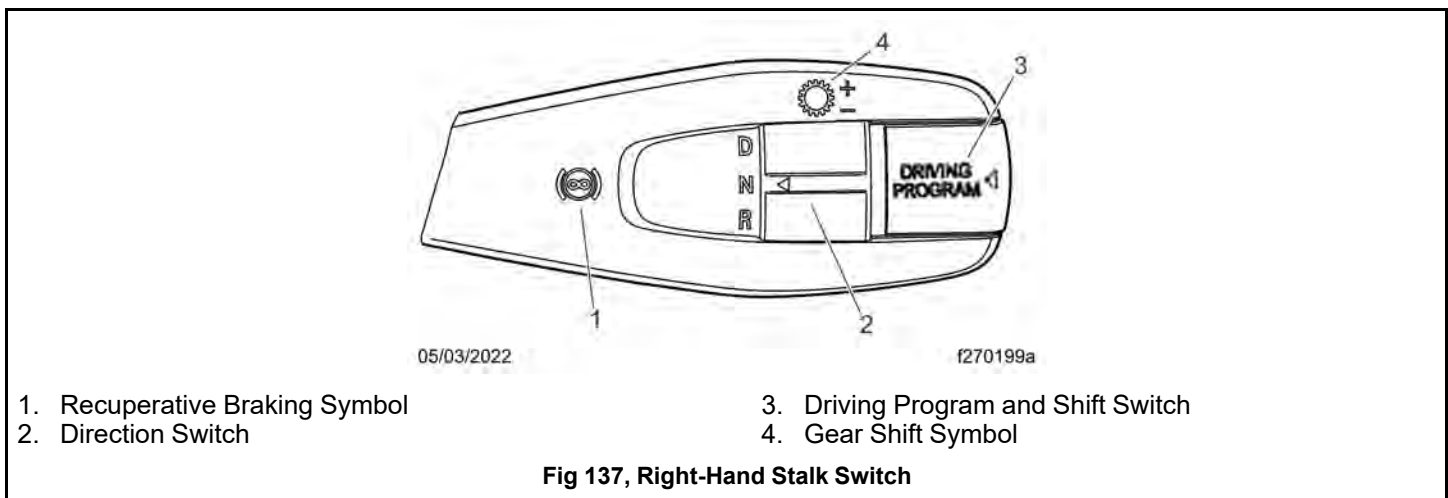

4. Turn the key in the keyswitch to the ON position. The high voltage system is turned on.
5. Wait for the system to do self-checks. Loud clicks are noticeable as the ABS system actuates the modulator valves. It may take up to a minute for a short buzzing sound to emit, indicating that the powertrain is ready.
6. Turn the key to the START position for a minimum of ½ second. After the vehicle has started the READY telltale, as shown, see Fig. 138, [ICC5 Driver Display Ready Icon](#), appears at the bottom of the power gauge on the driver's display.



NOTE: If the vehicle did not start up, or has a fault code, it may be necessary to restart the vehicle for the code to clear. Turn the key to the OFF position and wait until the dash goes dark. Repeat steps 4 through 6.

7. Press the brake pedal while shifting the vehicle into gear, disengage the park brake, then drive.

12.02.02 Driving Modes and Energy Efficiency

The vehicle can be equipped with three different driving program modes: economy, performance, and range. There is a boost mode available when in economy or performance mode.

The active driving mode displays as text in the center of the power gauge as shown, see Fig. 139, [Power Gauge](#). The driver can cycle through the available driving modes with a short press of the Driving Program switch, as shown, see Fig. 140, [Right-Hand Stalk Switch](#)

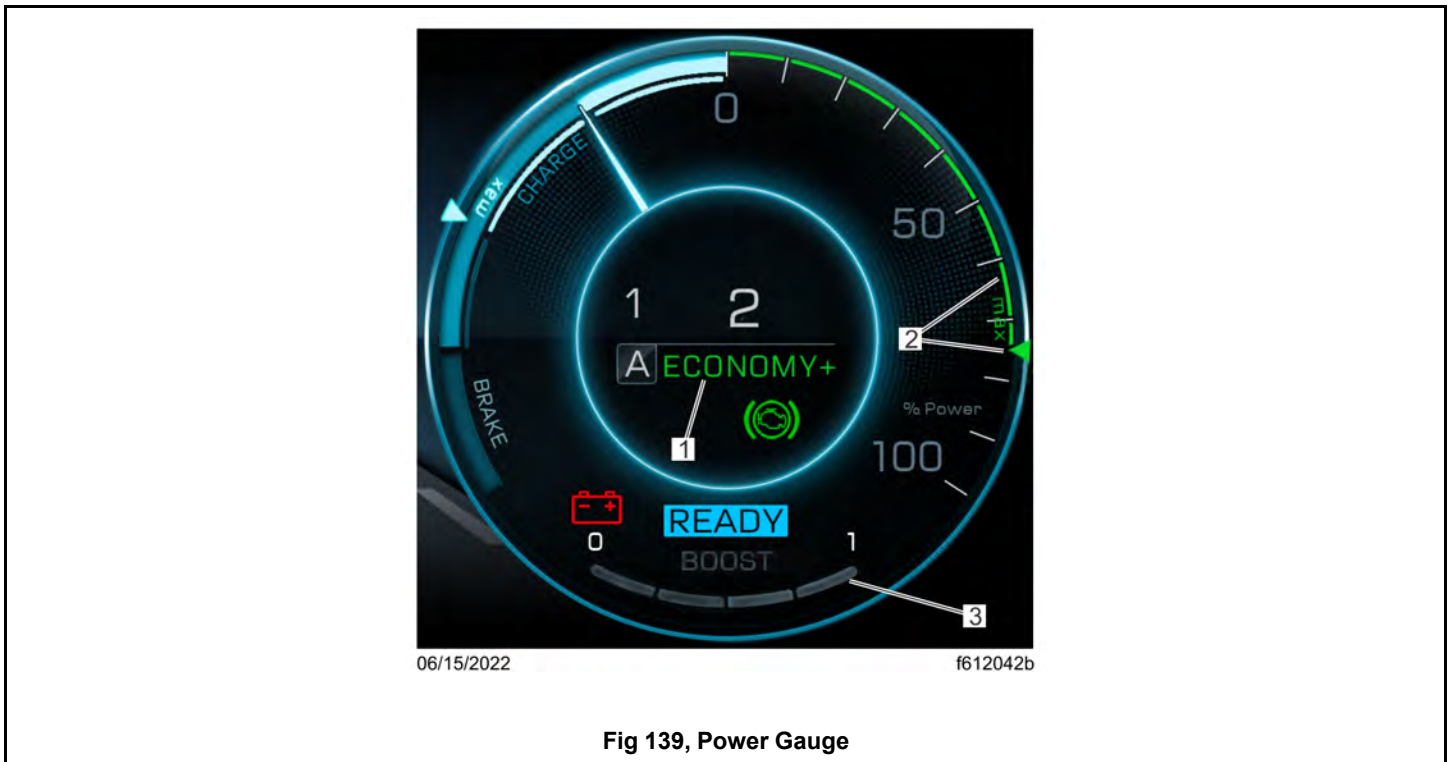

Fig 139, Power Gauge

Any reduction in performance associated with the current driving mode is shown with a green line capped with a caret on the power gauge. See Fig. 139, [Power Gauge](#). item 2.

Economy Mode

To encourage efficient driving behavior and reduce energy consumption, the default driving mode is economy. In economy driving mode, vehicle performance is slightly restricted to extend the vehicle's range. The power available in economy mode is marked by a green line and caret on the power gauge.

If equipped, boost mode is available in economy mode.

Performance Mode

If equipped, this driving mode increases vehicle performance and energy consumption and reduces the vehicle's range. Drivers should use performance mode only when acceleration is a priority.

As the green line and caret mark a limit in the amount of power available, they do not appear in performance mode.

If equipped, boost mode is available in performance mode.

Range Mode

In range driving mode there is an overall maximum vehicle speed limit of 55 mph (88 kph), HVAC performance is reduced, and boost mode is unavailable. This mode consumes the least energy and is for when the vehicle range is the primary concern.

As in economy mode, the power available is marked by a green line and caret on the power gauge.

If the high-voltage batteries drop to a 15 percent state of charge while in performance or economy mode, the vehicle automatically transitions into range mode. When transitioned into range mode by a low state of charge, the power gauge reduction is marked by an amber line and caret.

Boost Mode

Boost mode is used when there is a need to increase speed to pass or merge, or increase power to move a stationary vehicle forward on a steep grade. Both economy and performance driving modes can come with boost mode.

Press the accelerator pedal all the way to the floor (kick-down) to activate boost mode.

The boost status meter appears on the power gauge as shown, see Fig.139, [Power Gauge](#)

It displays the current boost power available as a white line. If no boost power is available the boost status meter appears grey. When boost mode is active, the boost status meter displays the power use as an amber line.

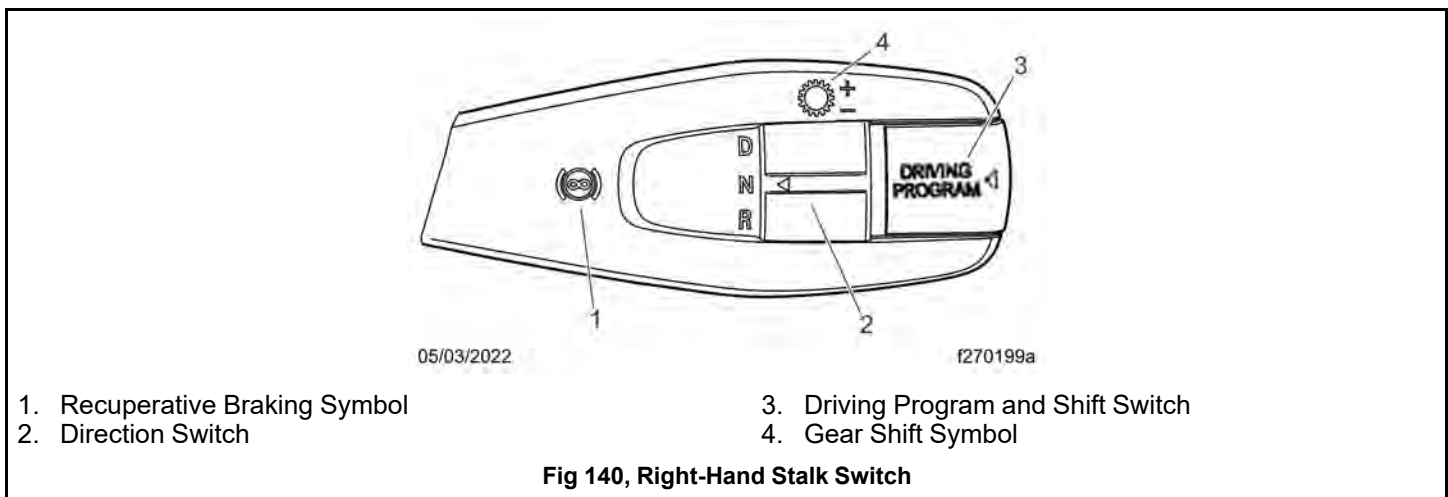

12.02.03 Normal Operation

The needle on the driver display power gauge, as shown, see Fig.141, [Power Gauge](#) shows how much available power is being used. When recuperative braking is active, the needle moves to the left of the zero; the trailing blue-white bar shows how much power is being fed to the batteries.

It's normal for the ePowertrain to experience reductions of power due to a variety of conditions, including:

- high ambient temperature,
- low ambient temperature,
- a high state of charge,
- a low state of charge.

If the loss of available power is connected to a diagnostic trouble code, take the vehicle to an authorized Freightliner service provider.

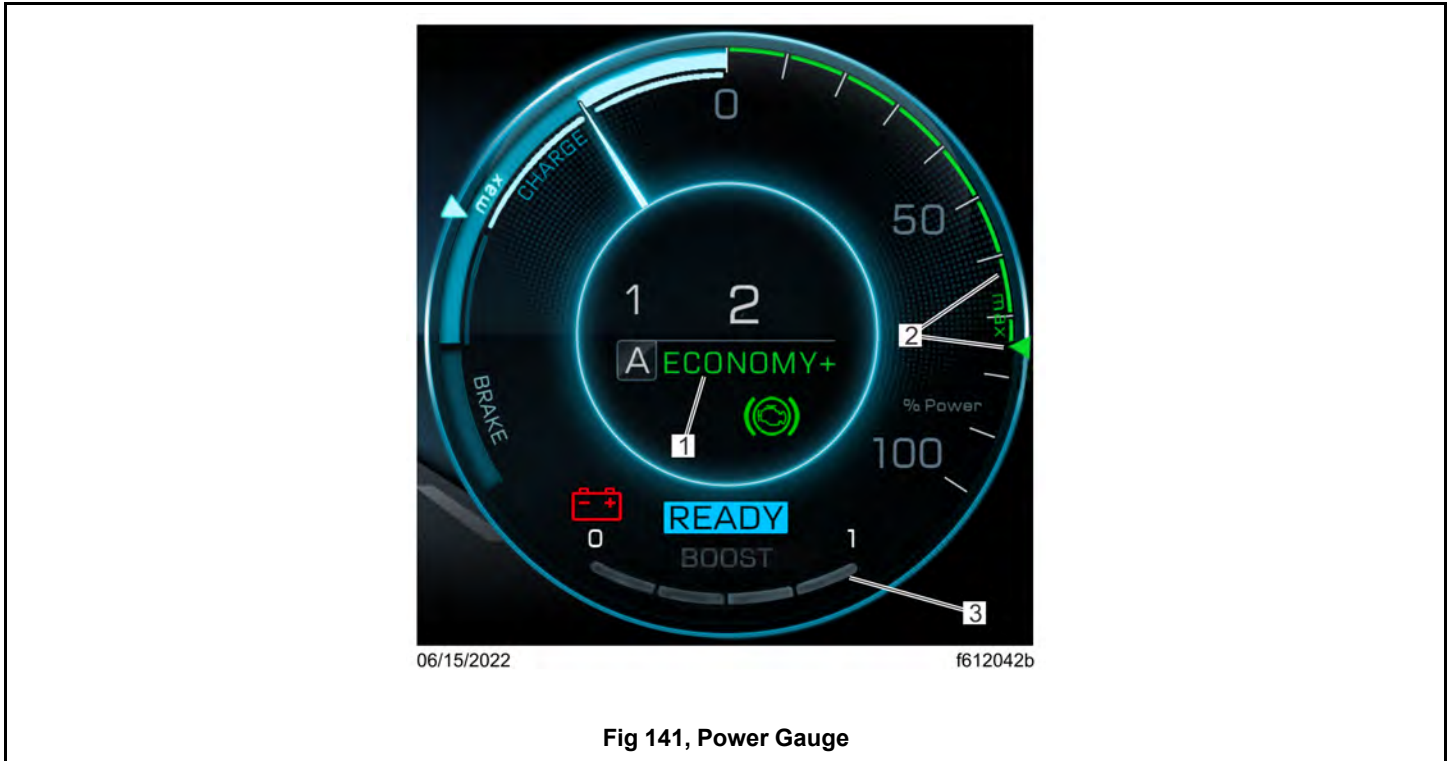

12.02.04 Predicted Range

NOTE: The predicted range display can be turned off at an authorised Freightliner dealer.

The predicted range at the base of the speedometer, as shown, see Fig.142, [Driver Display Speedometer](#) is a guideline.

The number is based on the high-voltage batteries current state of charge, current vehicle weight and speed, and travel history. The predicted range on a brand new vehicle is less accurate than on a vehicle that has been in service.



1. High-Voltage Battery Status
2. High-Voltage Battery State of Charge
3. Projected Range on Current State of Charge

Fig 142, Driver Display Speedometer

The actual range is affected by terrain, changing vehicle loads, changing vehicle speeds, driving behavior, environmental temperature, and auxiliary loads placed on the system.

If the vehicle load changes significantly, the remaining range is recalculated with the new range displaying within a minute.

- A terrain of steep hills and valleys reduces the vehicle range.
- Extremely hot or extremely cold conditions reduce the vehicle range. The vehicle is equipped with a thermal battery system to minimize loss of battery performance in both cold and hot weather, but the energy draw to heat and cool the batteries reduces the vehicle range.
- Running the cab heater or air conditioner, or any other auxiliary power draw, reduces the vehicle range.

12.02.05 Cold-Weather Operation

The eM2 vehicle is designed and tested for temperatures ranging from -4°F to 104°F (-20°C to 40°C).

If the vehicle is in good mechanical condition and the precautions necessary for cold-weather operation are followed, ordinary cold weather should not cause difficulty in starting and operating the vehicle.

IMPORTANT: Range performance, and the cab comfort/defrost performance, may reduce with lower temperatures. When temperatures are below -4°F (-20°C) leave the vehicle on the charger while parked to maximize the range and performance. If possible, park the vehicle inside, or find other ways to increase the ambient temperature of the vehicle.

12.02.06 Hot-Weather Operation

If the vehicle is in good mechanical condition and the precautions necessary for hot-weather operation are taken, ordinary hot weather should not cause difficulty in starting the vehicle or loss of efficiency in operating the vehicle.

12.02.07 Starting the Vehicle After an Extended Shutdown

Complete the applicable pre-trip inspections and maintenance procedures in **Chapter 17**

12.03 Vehicle Protection Warnings

12.03.01 General Information

The driver should be familiar with the different warning messages in order to bring the vehicle to a safe stop if necessary. If any vehicle system creates a false alarm, do **not** operate the vehicle until the issue has been corrected.

12.03.02 Low State of Charge and Low Range Warnings

NOTE: If the low-voltage batteries become completely discharged but the high-voltage batteries retain a charge, the vehicle can be jump-started. See **Chapter 18** for instructions.

The vehicle presents a series of notices, cautions, and warnings along with information from gauges and telltales to alert the driver to the high-voltage batteries having a low state of charge and the vehicle having a low remaining range.

If the state of charge and/or remaining range decreases beyond a certain point, driving is disabled. Charge the vehicle to enable driving.

12.03.03 State of Charge and Range Information

The high-voltage battery state of charge gauge at the bottom of the speedometer, as shown, see Fig. 143, [High-Voltage Batteries Normal Operation](#), represents the amount of energy stored in the batteries, with 0 representing a charge level too low to operate the vehicle and 1 representing fully charged high-voltage batteries.

The vehicle's estimated range appears above the state of charge gauge. This distance is based on the high-voltage batteries state of charge as well as the vehicle's weight, travel history, and current speed.

The telltale of stacked batteries to the left of the estimated range indicates the current status of the high-voltage batteries. The standard telltale that appears here is of stacked white batteries, as shown, see Fig. 143, [High-Voltage Batteries Normal Operation](#), which indicates normal operation.

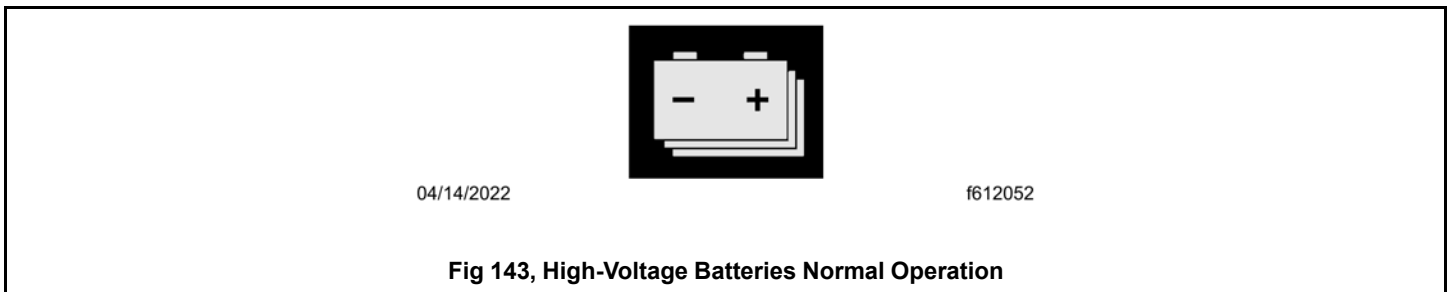

12.03.04 Low State of Charge Warnings

The state of charge bar graph has three color variations depending on the state of charge.

1. Flashing grey/blue: The vehicle is plugged in and charging. A blue plug appears in place of the white stacked batteries.
2. White: The high-voltage batteries have a normal state of charge. The white stacked batteries telltale is present.
3. Amber: A warning has been given about the high-voltage batteries state of charge. The stacked batteries telltale displays in amber as shown, see Fig. 144, [High-Voltage Battery State of Charge Low Telltale](#)
4. Flashing amber: A second warning has been given about the high-voltage batteries state of charge.



Fig 144, High-Voltage Battery State of Charge Low Telltale

The first notice about the high-voltage batteries state of charge occurs when it drops to approximately 15 percent.

If the vehicle is already in range mode, a low battery notice appears.

If the vehicle is in the economy or performance driving mode, dropping to a 15 percent state of charge triggers a low battery and activation of range mode notice, as shown, see Fig.

145, [Low High-Voltage Batteries State of Charge, Range Mode Activated Notice](#)



Fig 145, Low High-Voltage Batteries State of Charge, Range Mode Activated Notice

These notices can be dismissed by pressing the back button on the steering wheel.

If necessary, the driver may shift out of range driving mode.

The second notice is a warning, as shown, see Fig. 146, [Second Warning of Low State of Charge](#) and happens when the high-voltage batteries reach a state of charge of approximately 5 percent.



Fig 146, Second Warning of Low State of Charge

At this point, the estimated range ceases being calculated and displays as 0 miles or 0 kilometers and the state of charge bar graph flashes amber. If not active, range mode is activated; it is not possible to shift out of range mode. The maximum power line and caret on the power gauge displays in amber with the power limit defined by the amber caret steadily decreasing as vehicle performance is derated.

The driver should immediately bring the vehicle to a safe stop, apply the park brake, and turn off the ignition before the third warning, as shown, see Fig.147, [Third Warning, Low State of Charge](#) appears on the driver display screen.

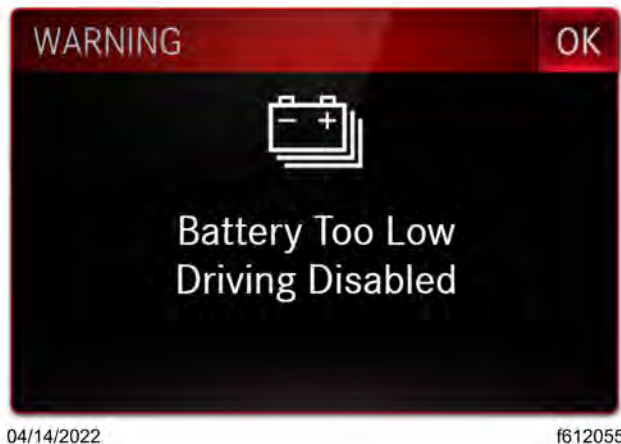

Fig 147, Third Warning, Low State of Charge

At this point the amber caret on the power gauge is at 0 percent and driving is not allowed.

Have the vehicle towed to a charging station. Towing instructions are contained in see [20.01 Shutting Down the High-Voltage System](#).

12.03.05 Low Range Warnings

There are two low remaining range warnings.

The first warning is turned off by default and the range estimate which triggers it is adjustable. It can be turned on and set in DiagnosticLink®, where it is named 'Battery Distance Low Warning Level 1.' When active and triggered, it drives the display as shown, see Fig.148, [First Warning of Low Remaining Range](#)

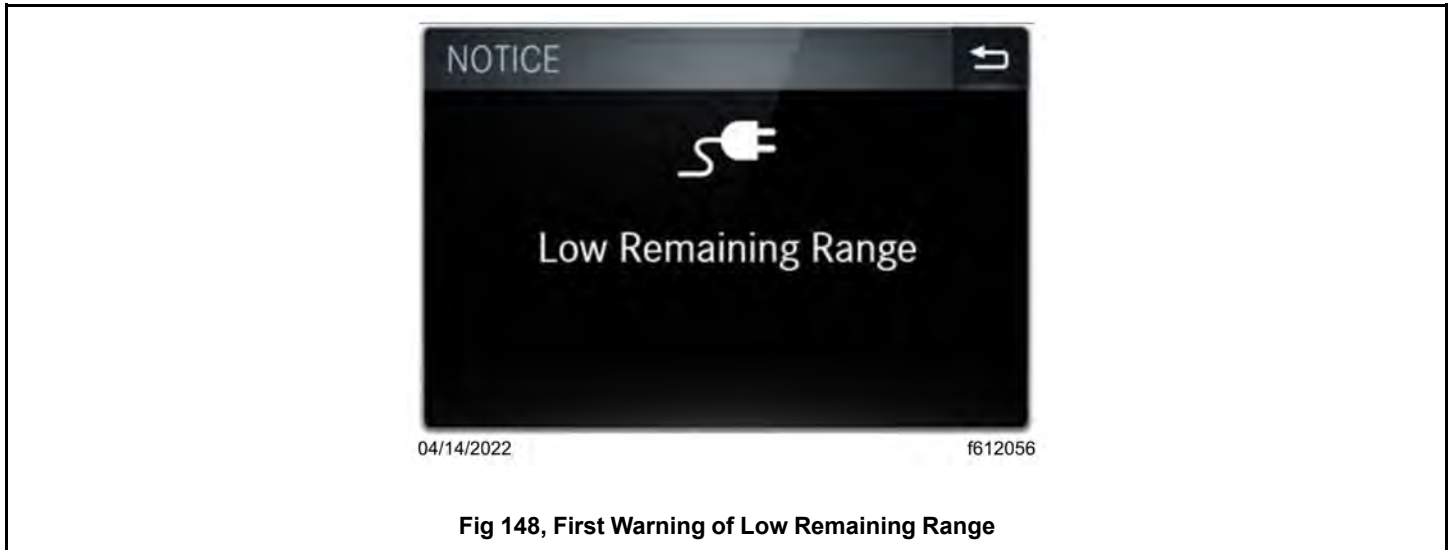

The second warning is triggered when the remaining range drops to approximately 15 miles (24 km). At this point a very low remaining range caution, as shown, see Fig.149, [Very Low Range Warning](#), appears and the range estimation display becomes unavailable.

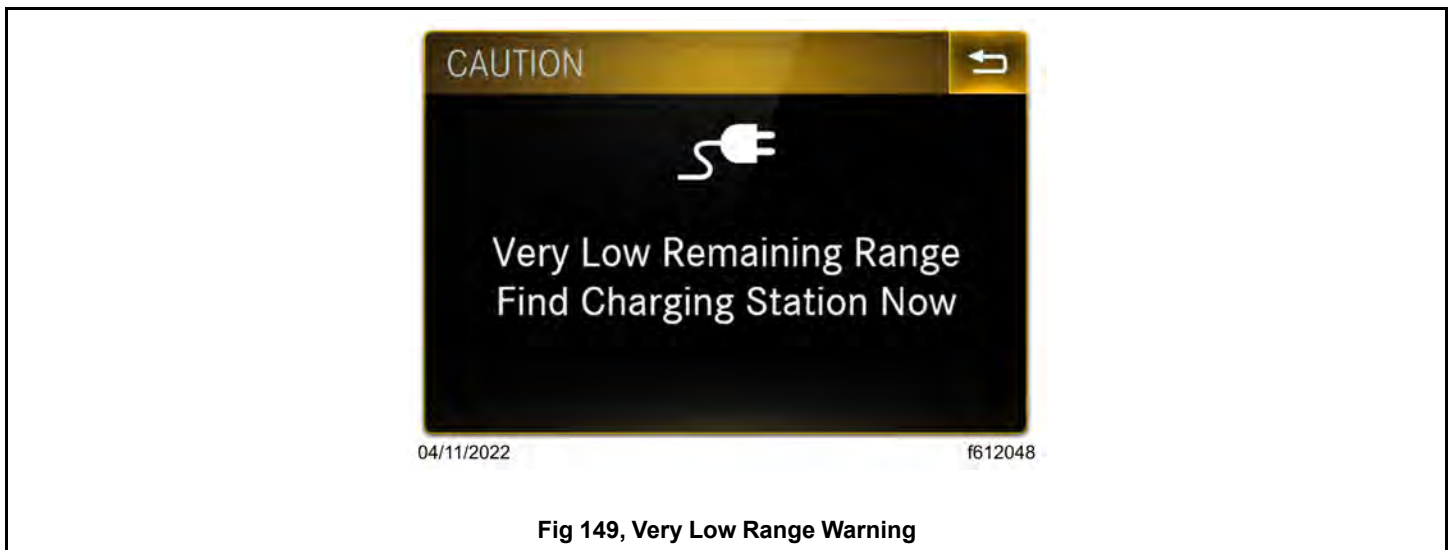

12.03.06 ePowertrain Telltales

There are two ePowertrain telltales, as shown, see Fig.150, [ePowertrain Problem Telltale](#) and see Fig. 151, [ePowerTrain Error Telltale](#). These telltales appear along with caution and warning windows about edrive malfunctions and issues with the high-voltage battery system.

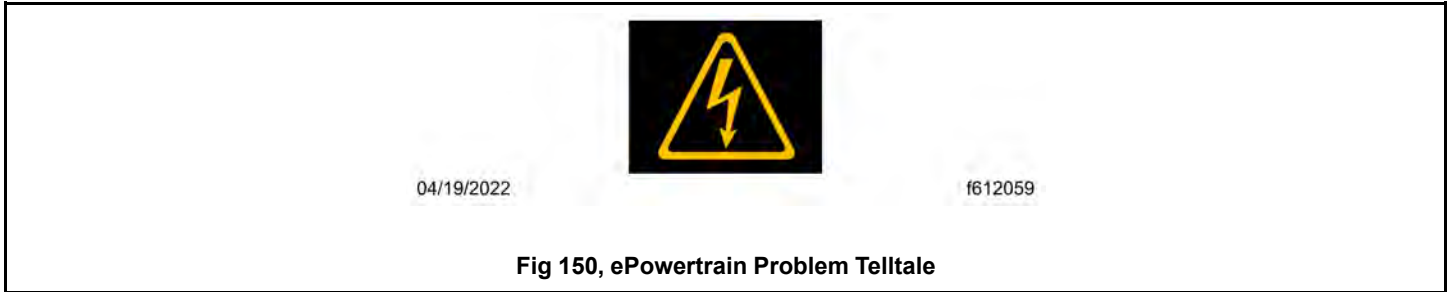

12.03.07 eDrive Malfunctions

A malfunctioning eDrive results in a cascade of windows, ranging from a notice informing the driver of reduced performance, as shown, see Fig.152, [eDrive Notice](#) to a caution notifying the driver to take the vehicle in for service, as shown, see Fig. 153, [eDrive Caution](#) to a warning that results in the vehicle shutting down, as shown, see Fig.154, [eDrive Warning](#)



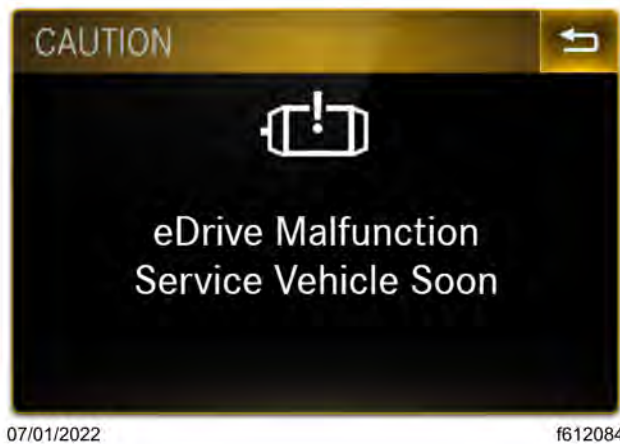

Fig 153, eDrive Caution



Fig 154, eDrive Warning

12.03.08 eMotor Overspeed Feature

**CAUTION:**

Failure to heed overspeed warnings may result in damage to the bearings and transmission of the vehicle, as well as potential damage to property, or personal injury.

This feature aims to prevent the motor speed from exceeding a series of thresholds by limiting power to the motor and presenting messages of increasing severity to the driver, instructing them to apply the service brakes.

If the eMotor's speed reaches the first threshold, power to the motor is reduced to slow the vehicle. If the truck is going downhill in manual mode, and is in first gear, the eMotor speed may still increase.

If the eMotor's speed reaches the motor's maximum limit, an amber caution appears, instructing the driver to apply the service brakes. See Fig.155, [eMotor Apply Brakes Caution](#). Do not rely on recuperative braking to slow the vehicle at this point.

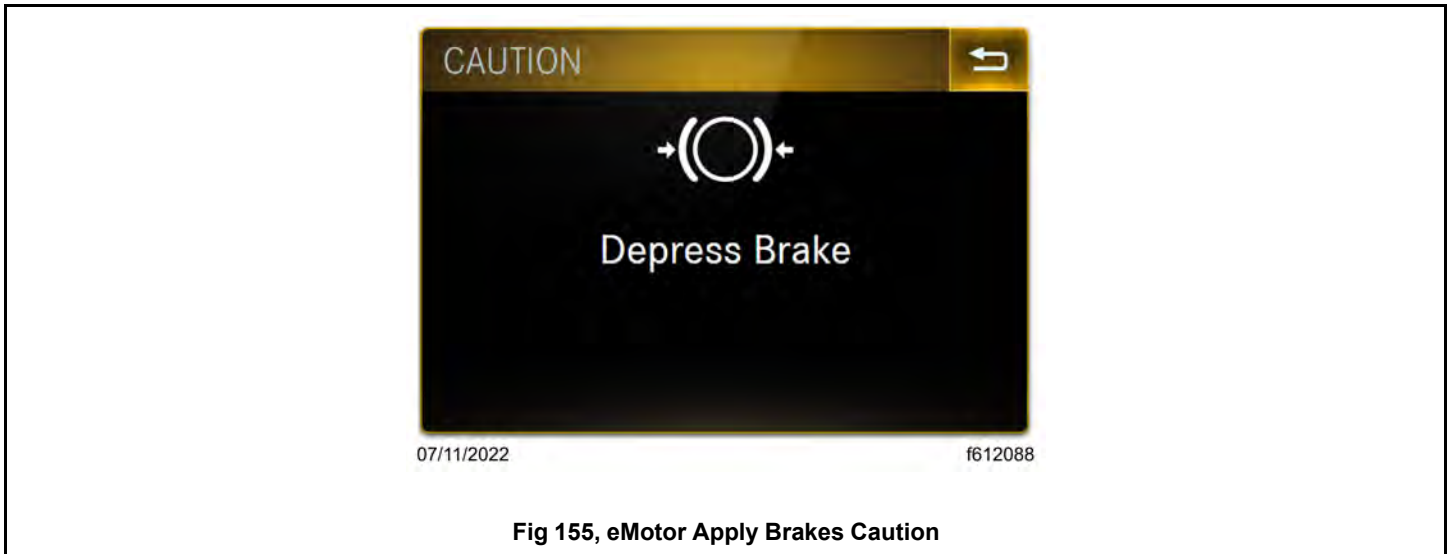

This caution can be dismissed by pressing the back button on the left-hand switch pod.

If the eMotor's speed exceeds the motor's limit, an acoustic alert activates and a red warning, as shown, see Fig. 156, [eMotor Overspeed Warning](#), instructs the driver to apply the service brakes.

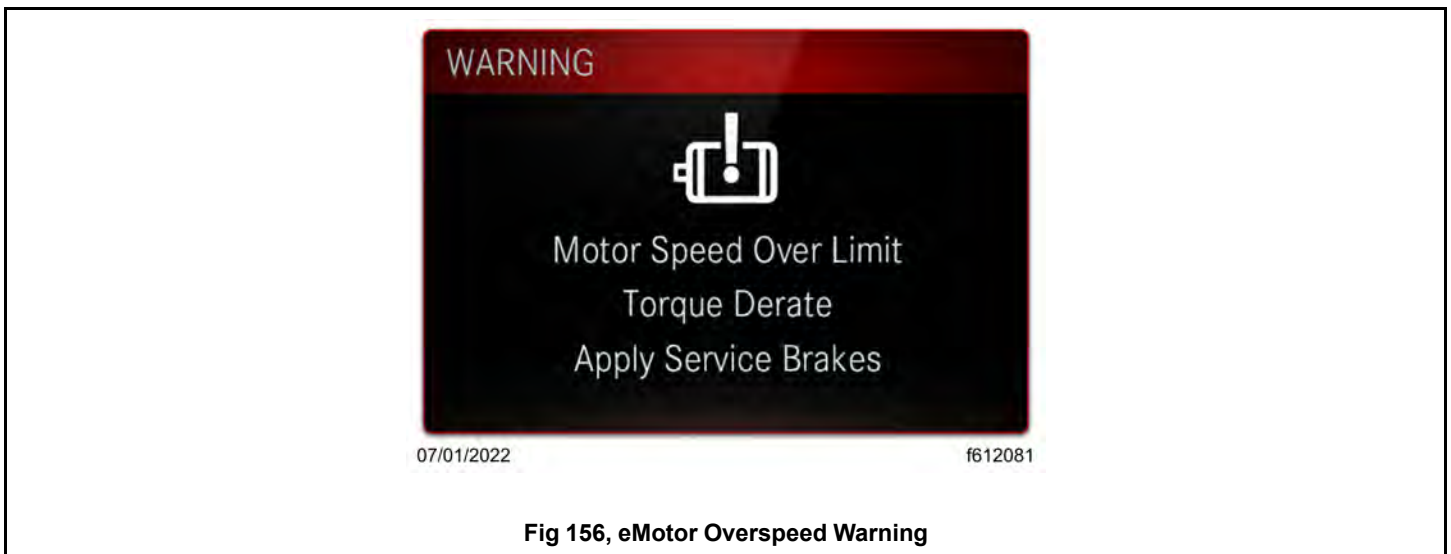

This warning cannot be dismissed.

12.03.09 High-Voltage Battery Warnings

There are a number of high-voltage battery cautions and warnings.

The high-voltage battery problem telltale, as shown, see Fig. 157, [High-Voltage Battery Problem Telltale](#), appears in the dynamic telltale portion of the driver display screen when a non-critical high-voltage battery fault has been detected. A minor issue that takes one of the nine high-voltage batteries offline is an example of a non-critical high-voltage battery fault. This telltale is a signal to take the vehicle in for service.

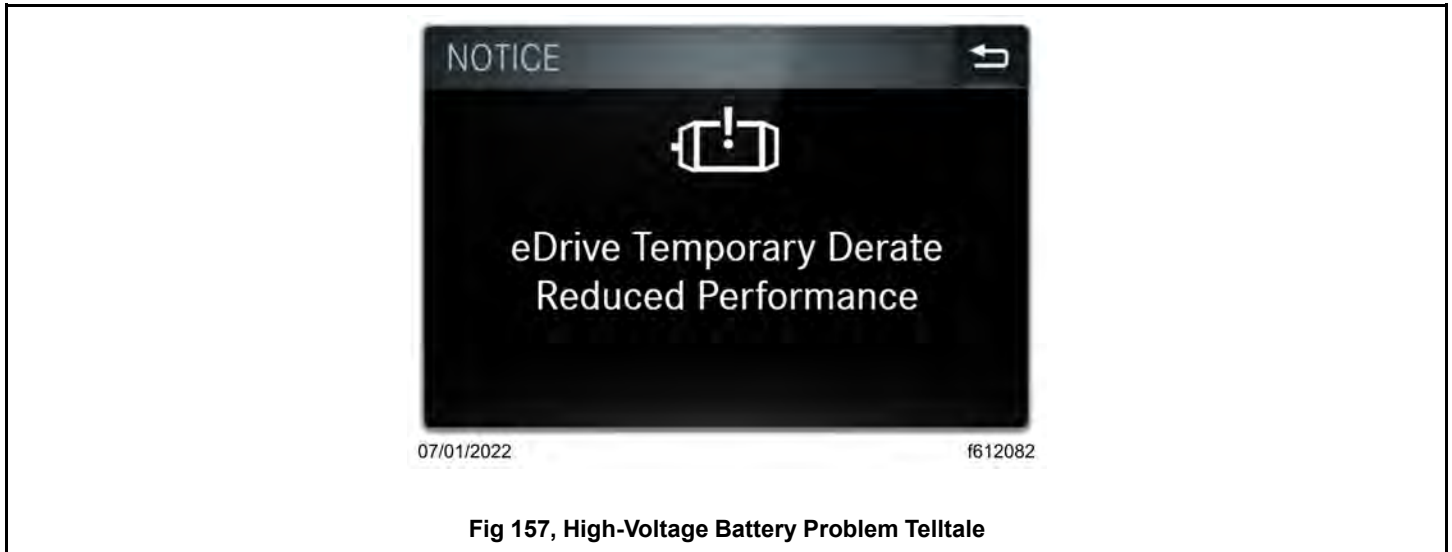

An amber caution window is also a signal to take the vehicle in for service.

An amber caution that states the driving range has been reduced, as shown, see Fig. 158, [High Voltage Battery Caution](#) for that a program derate has been activated, is a signal that the vehicle should be serviced soon.

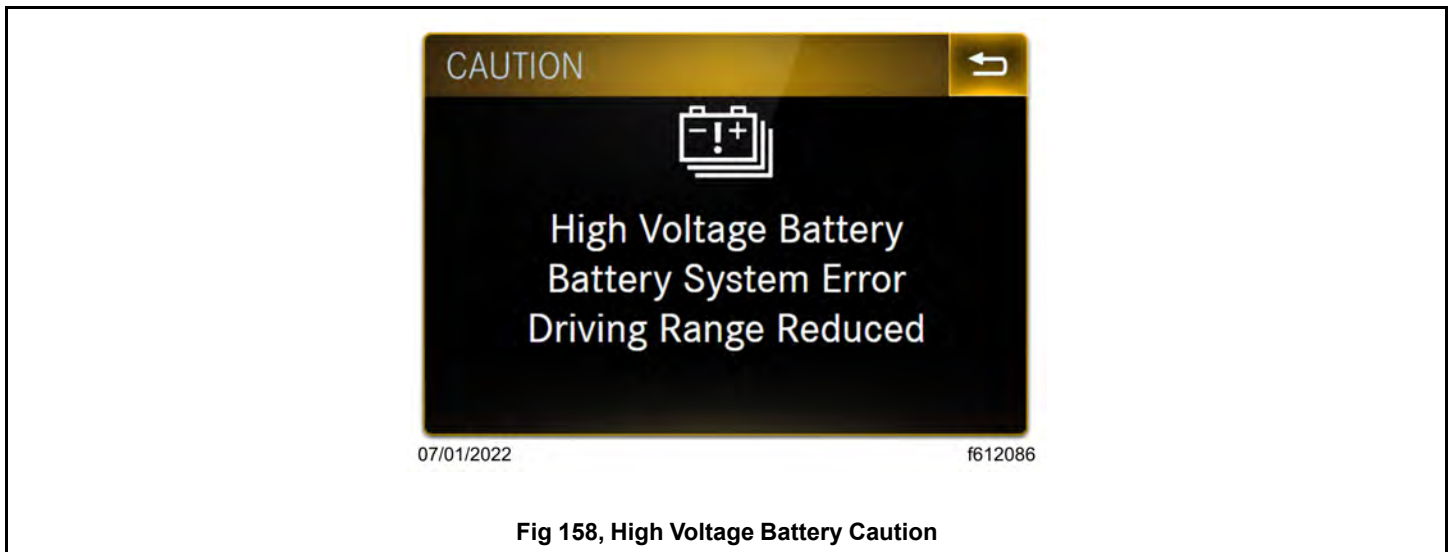

A red warning about a high-voltage battery situation, as shown, see Fig. 159, [High Voltage Battery Warning](#), should prompt moving the vehicle off the road to a safe location, turning the keyswitch to the off position, and a call for service.

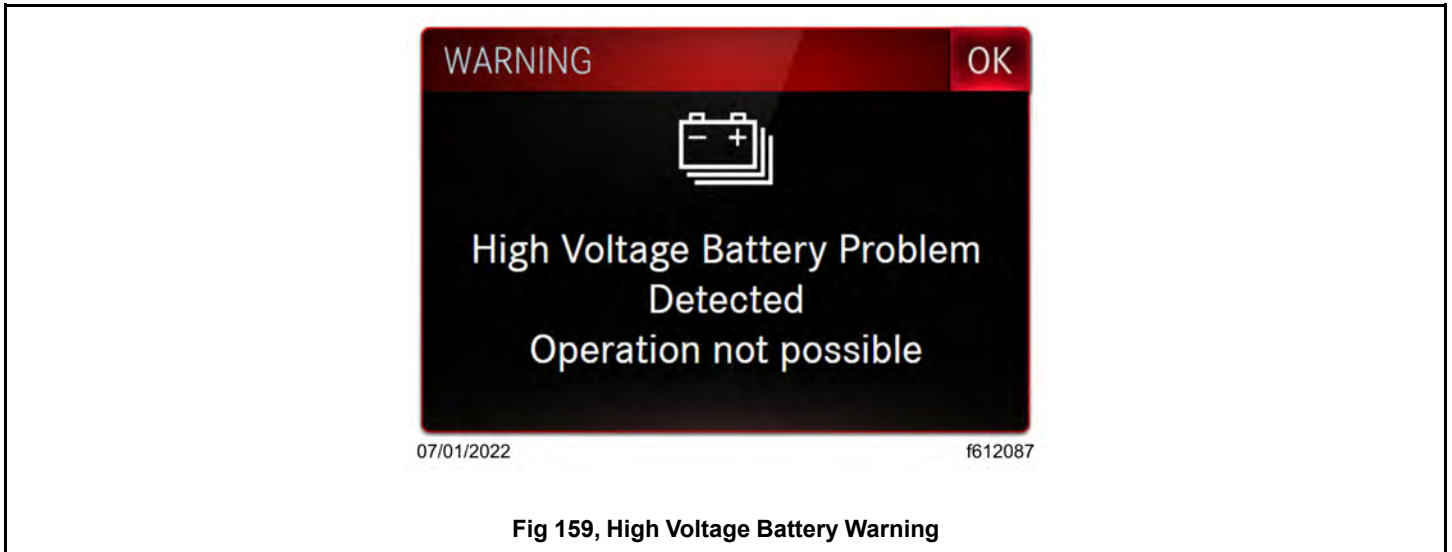

If a combustible gas detection system LED has illuminated or a high-voltage battery thermal event warning has appeared, exit the cab and call emergency services. For more information, see **Chapter 18**.

12.03.10 High-Voltage Battery Thermal Event Warning

If a thermal event is detected inside a high-voltage battery when the vehicle is on, the following things will happen:

- The red high-voltage battery thermal event telltale, as shown, see Fig. 160, [High-Voltage Battery Failure Telltale](#), appears in the dynamic telltale section of the driver display.
- A red warning message, as shown, see Fig. 161, [Thermal Event Warning Message](#), appears in the center of the driver display screen.





In response the driver should bring the vehicle to a safe stop, apply the park brake, turn the keyswitch to off, hit the eStop button, and exit the cab within five minutes. Once in a safe location, call emergency services.

For more information on this system, see **Chapter 18**.

12.03.11 Combustible Gas Detection System

If the explosive gas detection system sensors detects a 50 percent concentration of the lower explosive limit for a gas and maintains that level for six continuous seconds, a red LED on the system panel illuminates and an alarm sounds.

If a red LED illuminates when driving, quickly bring the vehicle to a safe stop. Apply the park brake, turn off the ignition, and press the eStop button on the dash prior to exiting the cab. Immediately call emergency services.

For more information on the combustible gas detection system, see **Chapter 18**.

12.04 Vehicle Shutdown

12.04.01 Standard Shutdown Procedure

1. With the vehicle stopped, set the parking brake and put the vehicle in neutral.
2. Turn the key to the off position to shut down the high-voltage system.
3. If the vehicle will remain parked for an extended amount of time, chock the tires.
4. If the vehicle is going to be parked for more than two days, turn off the cab load disconnect switch. The switch is located to the rear of the driver's seat on the door side and appears as as shown, see Fig. 162, [Cab Load Disconnect Switch](#).

To avoid accidental activation, the switch must be pressed and held for one second.



05/30/2023

f548209a

Fig 162, Cab Load Disconnect Switch

12.04.02 Emergency Shutdown Procedures

The high voltage system can be shut off in the following ways.

1. Turn the key to OFF and remove the key.
2. Press the eStop button located on the dash as shown, see Fig.163,[Emergency Shutdown Controls](#)



06/01/2023

f612218a

1. Hazard Warning Lights Switch

2. eStop Button

Fig 163, Emergency Shutdown Controls

A lock can be inserted through the eStop button guard to keep the button depressed.

- In addition, for the use of emergency responders, a cut through cable access point, as shown, see Fig. 164, [Cable Cut Through Point](#), exists below each cab door. If the eStop button on the dash cannot be accessed, emergency responders can cut the wiring at either of these locations.



06/01/2023

f548240

Fig 164, Cable Cut Through Point

12.05 High-Voltage Battery State-of-Health and Deactivation Notifications

As the high-voltage batteries near end-of-life, there are a series of three escalating pop-up messages that indicate the state of battery health. There are also two telltales associated with the caution and warning pop-ups described below, that illuminate during the respective battery state-of-health scenarios.

NOTE: If the vehicle's software is not up-to-date, the pop-ups may not appear on the driver display screen. The telltales illuminate regardless of vehicle software version.

The first notice, as shown in Fig. 165, [High-Voltage Battery Deactivation Notice](#), appears on the driver display screen 44 to 31 days before battery replacement is needed. When this pop-up appears, schedule battery replacement service with an authorized Freightliner dealer. To acknowledge the notice, select 'OK.'

There is no telltale associated with this notice.

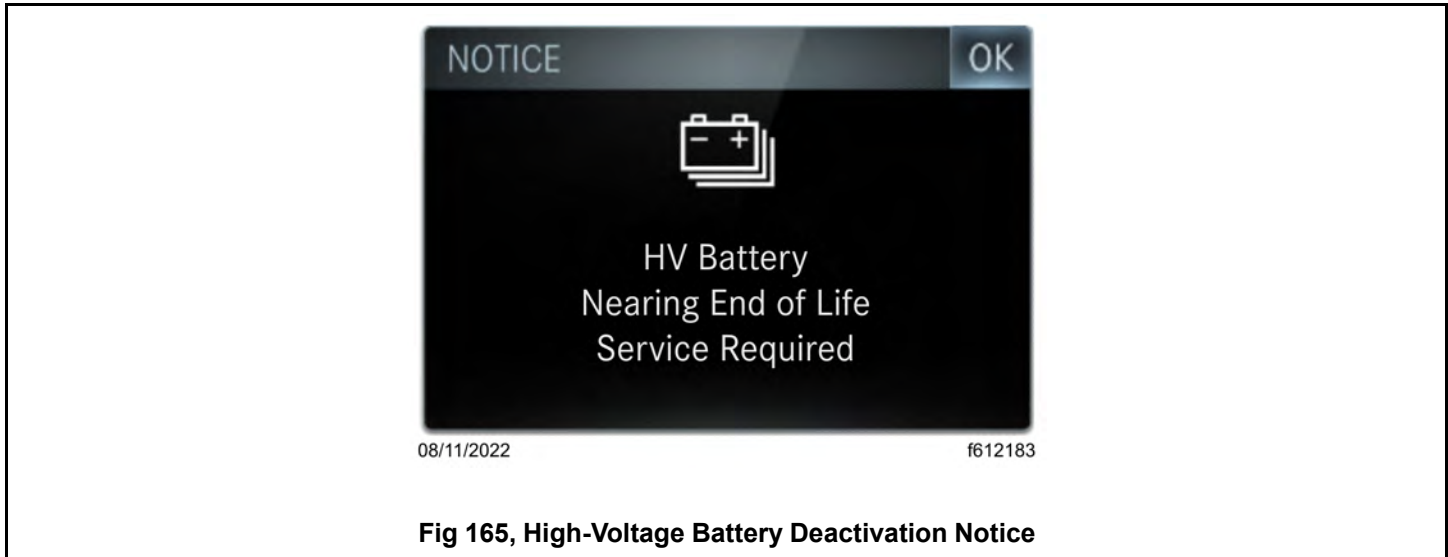

Fig 165, High-Voltage Battery Deactivation Notice

The second caution message, as shown in Fig. 166, [High-Voltage Battery Deactivation Caution](#), appears on the driver display screen every day for 30 calendar days until the truck disables itself. The caution screen shows the number of days remaining until shutdown and continues to count down. If not already completed, schedule battery replacement service with an authorized Freightliner dealer as soon as possible. To acknowledge the notice, select 'OK.'

The telltale associated with this pop-up is the same amber telltale named 'High-Voltage Battery Problem,' shown in the Table in the topic.

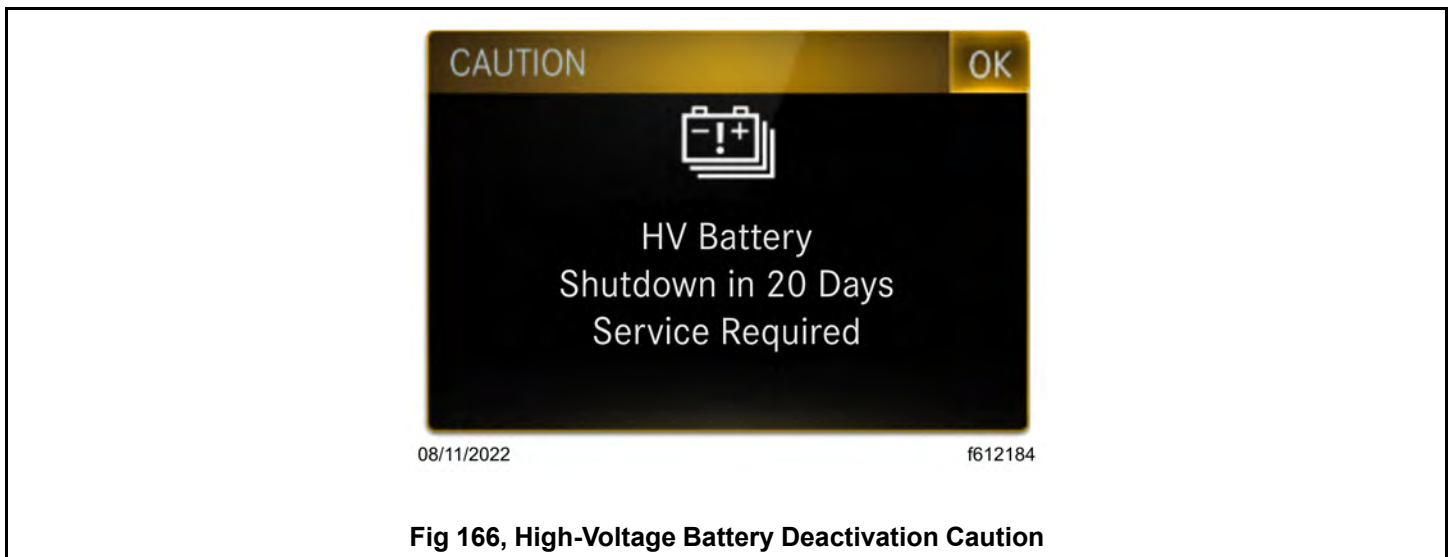
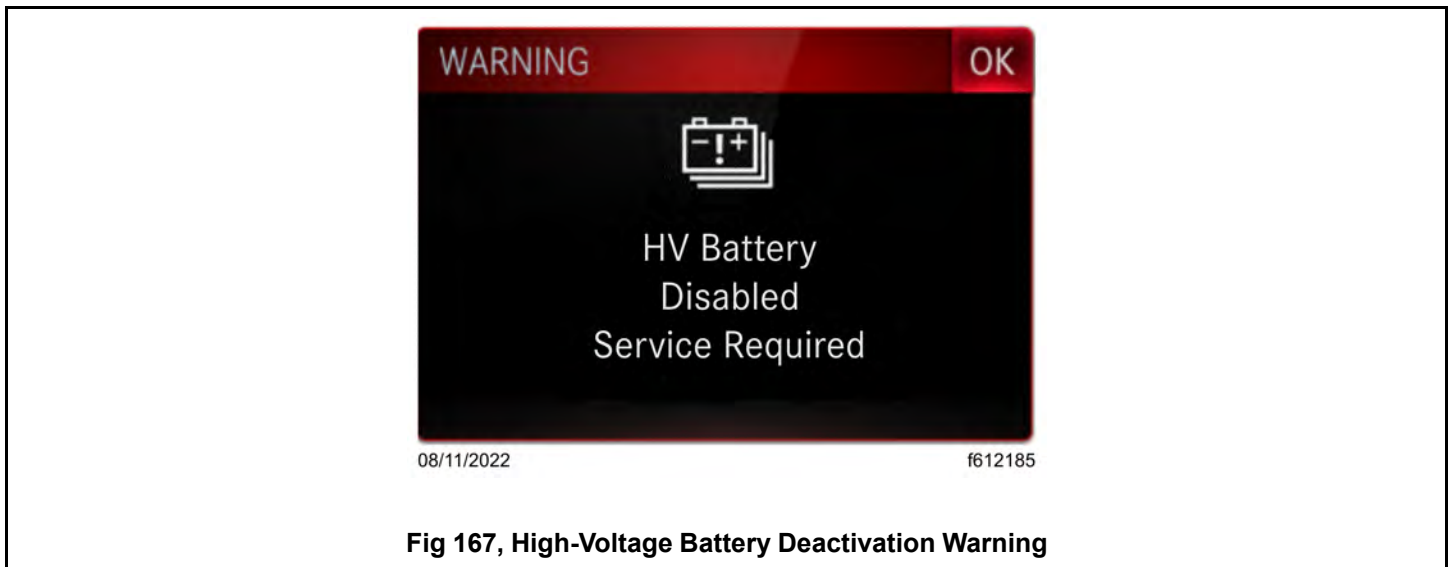

Fig 166, High-Voltage Battery Deactivation Caution

The third and final warning, as shown in Fig. 167, [High-Voltage Battery Deactivation Warning](#), appears if battery service is not completed. If the keyswitch is turned OFF for more than one hour, the battery state of health will be too low for high voltage to be turned back ON, making the vehicle undrivable. If this happens, the vehicle will need to be towed to a service center for battery replacement. This warning disappears when the battery is replaced.

The telltale associated with this pop-up is the same red telltale named 'High-Voltage Battery Failure,' shown in the Table in the topic. This telltale also illuminates when the vehicle detects a thermal event in a high-voltage battery. If the telltale is

active and the pop-up below (titled 'HV Battery Disabled Service Required') does NOT appear, out of an abundance of caution, bring the vehicle to a safe stop, apply the park brake, turn the keyswitch to off, and exit the cab within the next five minutes.



12.06 ePowertrain Telltales

Telltales and messages appear on the driver display. The positions of the telltales vary, but most use standard symbols.

The colors of telltales indicate the hazard level as follows: red (warning), amber (caution), green (normal function), blue (active status), grey (passive status), white (informational).

The colors of messages indicate the hazard level as follows: red (warning), amber (caution), grey (informational). See Table 26, [ePowertrain Telltale Lamps and Messages](#).

NOTE: For information on the features that use these telltales, see chapters 10 and 19.











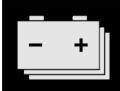

Telltale	Color	Description		Related Messages
	Blue	Charger Connected to Vehicle	A flashing telltale indicates the vehicle is actively charging. Solid illumination indicates the desired state of charge has been reached and that the charger is connected to the vehicle.	When a charging coupler is plugged into the vehicle, the vehicle's ability to drive is inhibited.
	Blue	Powertrain Active	Signals that the ePowertrain is activated and the vehicle is ready to drive.	If a door is opened when the parking brake is disengaged and the powertrain is active, a popup appears.
	Amber	Low-Voltage Battery Problem	A low-voltage battery problem has been detected.	

Table 26, ePowertrain Telltale Lamps and Messages

Telltale	Color	Description		Related Messages
	Red	Low-Voltage Battery Failure	The low-voltage batteries have failed or cannot be detected.	
	White	High-Voltage Battery Charge Normal Operation	The high-voltage batteries have a high enough charge to operate the vehicle.	
	Amber	High-Voltage Battery Charge Low	Indicates an state of charge warning is active. Turn off unneeded features drawing power. Drive the vehicle for 30-60 minutes, or manually charge the low-voltage batteries.	
	Amber	High-Voltage Battery Problem	Indicates a non-critical battery fault, such as one of the high-voltage batteries going offline or nearing end-of-life. Take the vehicle in for service.	
	Red	High-Voltage Battery Failure	A thermal event has been detected inside a high-voltage battery. Bring the vehicle to a safe stop, apply the park brake, turn the keyswitch to off, and exit the cab within the next five minutes. If there is time, press in the eS-top button.	The vehicle must be on for the high-voltage battery thermal event detection system to be active.
	Amber	ePowertrain problem	A high-voltage battery or ePowertrain problem has been detected. A derate program has been activated or the driving range has been reduced. Take the vehicle in for service.	
	Red	ePowertrain Error	A high-voltage battery or ePowertrain problem has been detected. Stop immediately.	
	Amber	eDrive problem	An eDrive problem has been detected	
	Red	eDrive error	And eDrive error has been detected	

13.01 Recuperative Braking	196
13.02 Energy Waste Mode	198
13.03 Descent Control	198
13.04 Hill Start Aid	199
13.05 Hold Function.....	200
13.06 Air Brake System.....	201
13.06.01 General Information	201
13.06.02 Air Brake System Operation.....	203
13.06.03 Automatic Slack Adjusters	205
13.07 ZF™ Antilock Braking System	205
13.07.01 General Information	205
13.08 Automatic Traction Control.....	206
13.09 Brake and Traction Telltales	207

13. Brake Systems

13.01 Recuperative Braking

NOTE: Activating recuperative braking while in cruise control can be used to activate descent control mode or deceleration mode.

IMPORTANT: Recuperative braking is not recommended in icy or snowy conditions.

The truck is equipped with a recuperative braking system. When recuperative braking is active, the motor acts as a generator, resisting the rotation of the wheels and creating electricity.

When the driver sets the right-hand stalk switch to low, medium or high, presses on the brake pedal, or a driver assistance system demands the vehicle decelerate, the vehicle is able to use some of the energy used to slow the vehicle to charge the high-voltage batteries.

If the vehicle is equipped with dynamic recuperative braking using the accelerator pedal, then using the accelerator pedal can engage recuperative braking.

Engaging Recuperative Braking



WARNING:

Recuperative braking may be inhibited. The driver should always be prepared to apply the service brakes to slow the vehicle. Failure to do so could result in damage to the vehicle, severe personal injury, or death.

To activate recuperative braking with the right-hand stalk switch, select position one through three, as shown in Fig. 168, [Recuperative Braking Positions](#).

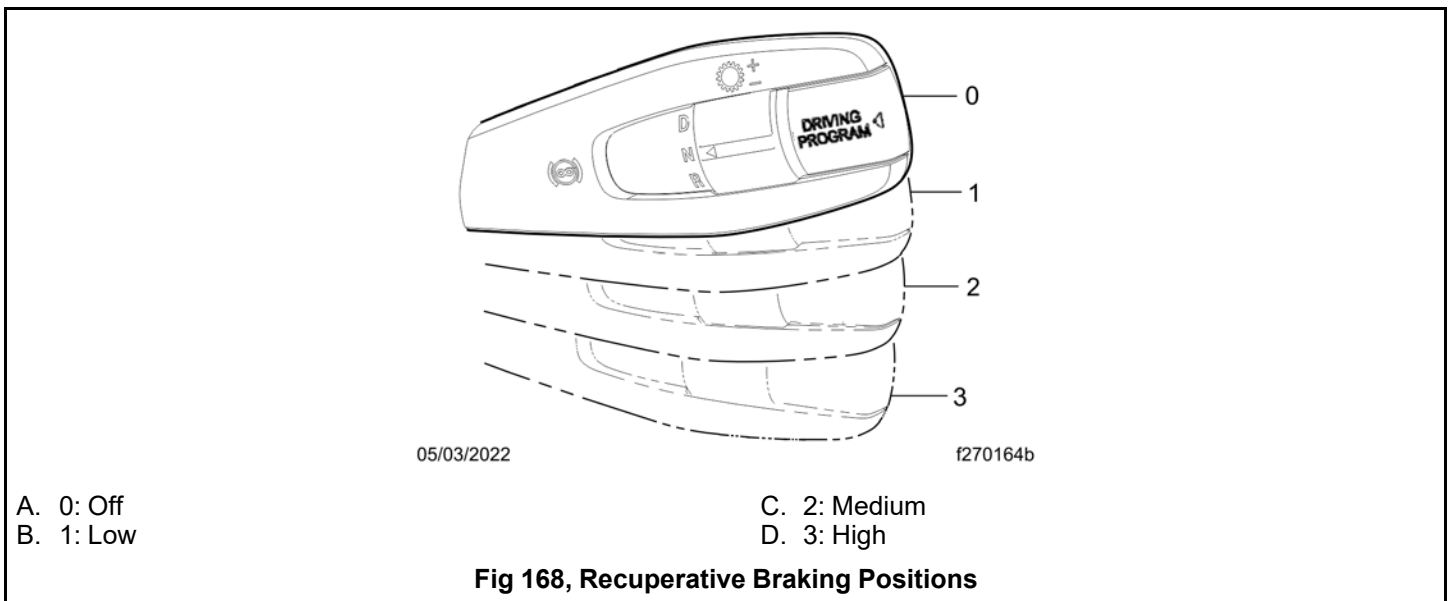

When a recuperative braking level is selected, the recuperative braking telltale shown in Fig. 169, [Recuperative Braking Telltale](#) appears on the driver display.



A thin inner blue line also appears on the charge meter section of the power gauge, as shown in Fig. 170, [Power Gauge](#) indicating the maximum level of recuperative braking requested. Each level (low, medium, high) extends the line by 1/3 until the line extends the length of the meter at 'high.' If level one or two is selected, a blue caret appears to mark the recuperative braking limit. If level three is requested, there is no limit and therefore no caret.

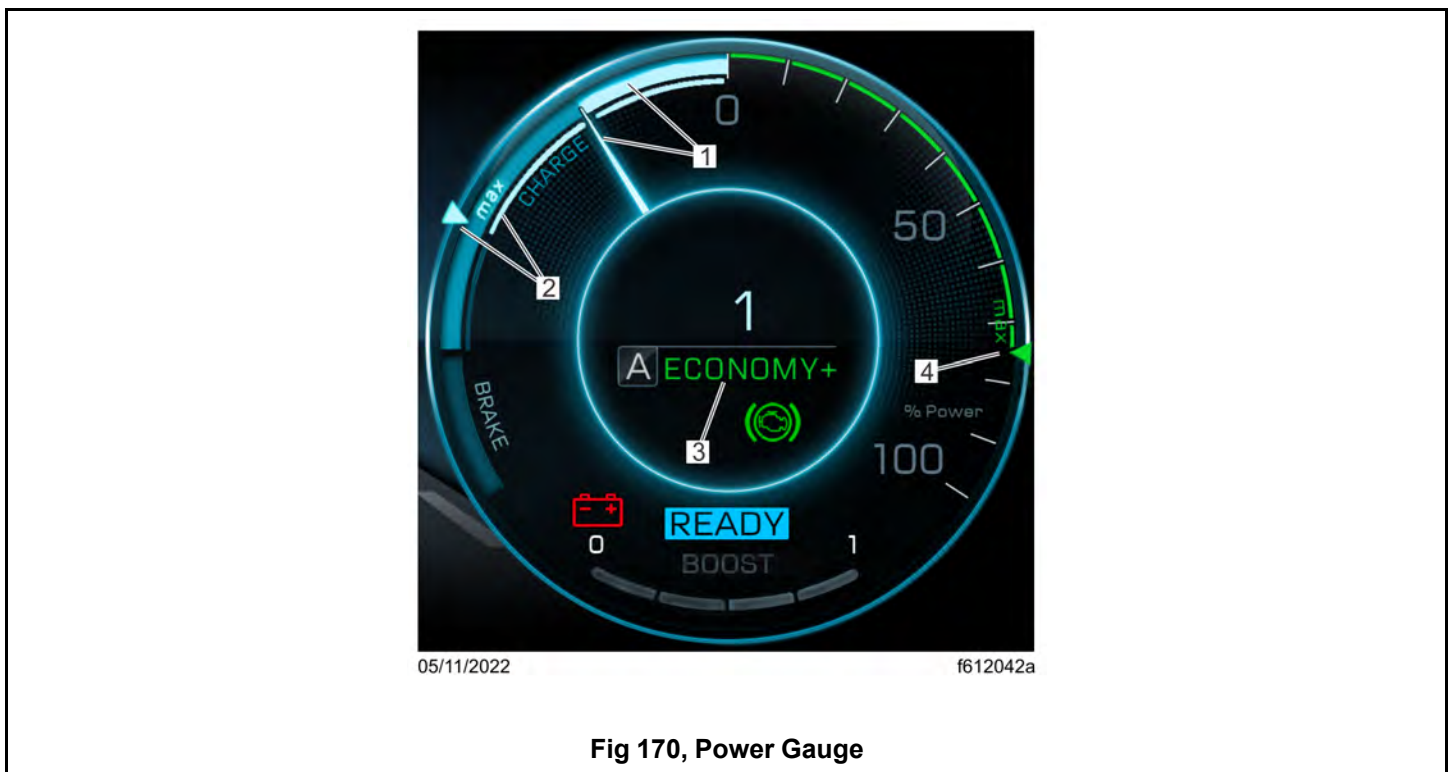

A dynamic thick outer blue line led by a electronic needle communicates the amount of recuperative braking power being generated at any moment.

Pressing on the accelerator pedal, putting the vehicle in neutral, or moving the right-hand stalk switch to the off position deactivates the recuperative braking charge request.

If the right-hand stalk switch is in the low, medium, or high position when the keyswitch is turned on, the recuperative brake telltale, shown in Fig. 169, [Recuperative Braking Telltale](#) flashes and recuperative braking is disabled. To enable recuperative braking and stop the telltale from flashing, move the right-hand stalk switch to the off position.

Recuperative Braking Limitations

A number of dynamic conditions affect the active amount of recuperative braking power generated. These include the vehicle's speed, mass, the terrain, and the high-voltage batteries current state of charge (SOC). Recuperative braking is limited if the batteries have a high SOC. It may also be limited if the high-voltage batteries are cold.

If the recuperative braking is limited, or severely limited, the driver is notified of this limitation through a message appearing on the driver's display.

Dynamic Recuperative Braking Using the Accelerator Pedal

If equipped with dynamic recuperative braking using the accelerator pedal, the driver can engage recuperative braking when lifting their foot off the accelerator pedal at speeds above approximately 20 mph (32 km). At low speeds, such as when in stop and go traffic, there is little to no kinetic energy to be captured through recuperative braking.

To activate recuperative braking using the accelerator pedal, the right-hand stalk switch must be requesting recuperative braking power at a low, medium, or high level. This level may act as a limit to the amount of recuperative braking power that can be recouped from a slowing vehicle, therefore DTNA suggests setting the stalk switch to high to allow the driver to regulate the amount of recuperative braking through modulating the pressure on the accelerator pedal.

When the driver lifts their foot off the accelerator pedal with the right-hand stalk switch engaged, the electric motor immediately uses the kinetic energy of the vehicle to charge the batteries, slowing the vehicle. Using this feature in traffic allows a driver to extend the vehicle's range.

When the vehicle is coasting, the recuperative braking needle sits at zero.

13.02 Energy Waste Mode

This mode improves braking performance by providing a base level of recuperative braking when the high-voltage batteries limit charging, such as when the batteries are at a high SOC.

To reduce stress on the service brakes when recuperative braking is limited, energy waste mode activates thermal management components (the AC compressor, pumps, and fans) to increase power consumption to increase available recuperative braking capacity. When active, energy waste mode creates a loud humming noise.

13.03 Descent Control

NOTE: If the high-voltage batteries are fully charged, recuperative braking is not available.

Descent control mode attempts to keep the vehicle below a set speed on a downhill slope by using all available recuperative braking stages.

To activate descent control mode, remove your foot from the accelerator pedal, set the right-hand stalk switch to any of the three 'on' positions (1, 2, or 3) as shown in Fig. 172, [Recuperative Braking Positions](#) and then use the set or resume buttons to set the vehicle speed. The descent control mode telltale, shown in Fig. 171, [Descent Mode Telltale](#) illuminates on the driver display when descent control mode is active.



Fig 171, Descent Mode Telltale

As descent control mode is not designed to keep the vehicle **above** any set speed, it is possible to eventually coast to a stop unless the accelerator pedal is applied or the right-hand stalk switch is moved to the 'off' position (0).

If the accelerator pedal is applied, the descent control mode resumes when the accelerator pedal is released.

Moving the right-hand stalk switch to the 'off' position deactivates descent control mode and resumes cruise control, using the descent control set speed as the cruise control set speed.

In the case of very steep grades, recuperative braking may not be able to maintain the vehicle speed below the set speed. In these circumstances, the driver can apply the service brakes to slow the vehicle below the set speed without dropping out of descent control mode. However, after releasing the service brakes, a new cruise set speed lower than the original set speed is set. The driver is informed of this new set speed by a message on the driver display.

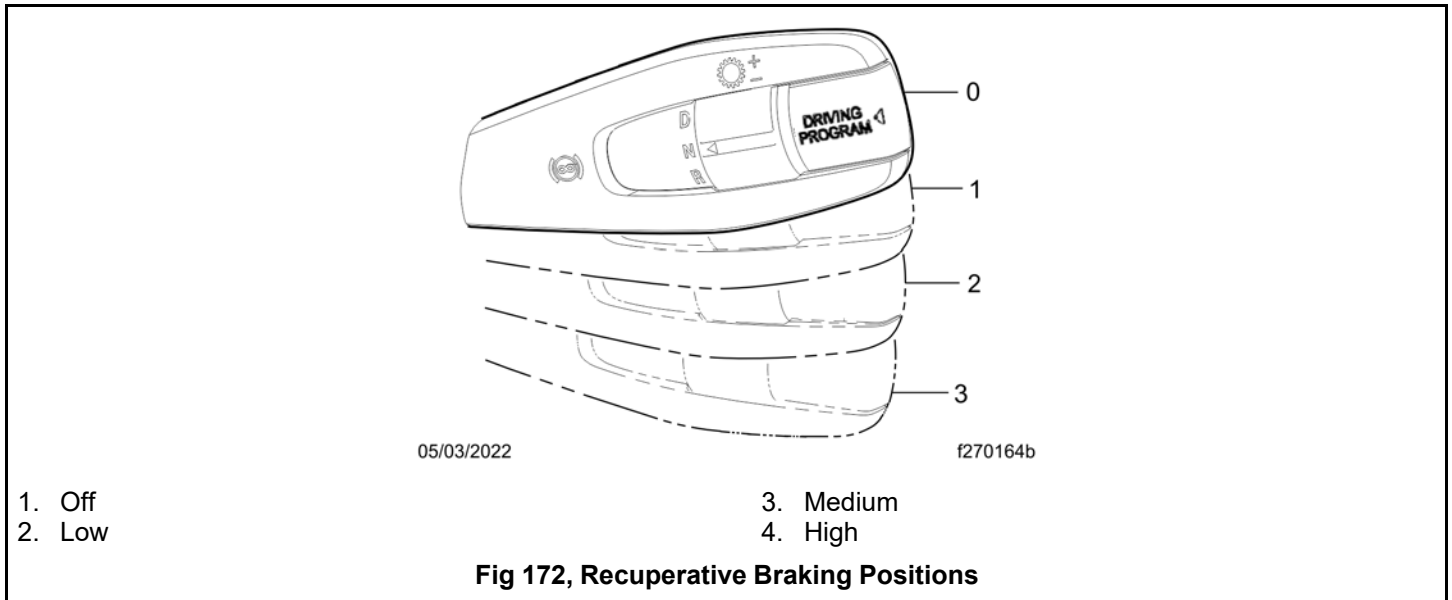

13.04 Hill Start Aid

The hill start aid (HSA) feature prevents the vehicle from rolling on a slope steeper than three percent to allow for a controlled launch.

HSA prevents a stationary vehicle in forward gear from rolling downhill prior to continuing to drive up the hill; HSA also prevents a stationary vehicle in reverse gear from rolling downhill prior to continuing to back up the hill.

HSA delays the release of service brakes until enough torque is available to begin moving the vehicle, up to a maximum of three seconds. If sufficient driveline torque is not detected after three seconds, the system audibly alerts the driver and releases the brakes.

HSA is on by default. It can be turned off by pressing the HSA OFF dash switch shown in Fig. 173, [Hill Start Aid Off Dash Switch](#).



When hill start aid is inactive, the HSA OFF telltale, shown in Fig. 174, [Hill Start Aid Disengaged Telltale](#) flashes on the driver display screen.



To turn hill start aid on again, press the HSA OFF switch or cycle the vehicle keyswitch.

If the hill start aid disengaged telltale appears as a solid image on the driver display screen, there is a fault in the system.

13.05 Hold Function

The hold function eases the strain of driving in stop-and-go traffic by allowing the driver to "hold" the brake without constantly applying pressure to the brake pedal. The hold function is an extension of hill start aid (HSA).

To activate the hold function, bring the vehicle to a complete stop, then press the brake pedal further toward the floor. The HOLD telltale, shown in Fig. 175, [Brake Hold Active Telltale](#) illuminates on the driver display to indicate the function is active and the vehicle's brake lights come on. The driver can then take their foot off the brake pedal without releasing the service brakes.

If the brake pedal is pressed down farther, air is added to the chamber, continuing the brake hold.



Fig 175, Brake Hold Active Telltale

To release the brake hold, press the accelerator pedal, engage the park brake, or rapidly apply and release the brake pedal.

The hold function is deactivated when the HSA OFF switch is pressed to disable HSA.

The hold function cannot be engaged if any of the following are true:

- the anti-lock braking system was active in bringing the vehicle to a stop,
- the anti-lock braking system is in a fault state, or
- the vehicle is in reverse gear.

If the hold function is active for four minutes, the window shown in Fig. 176, [Engage Park Brake Message - ICC5](#), appears on the ICU warning the driver to engage the park brake. An audible alarm activates at the same time and repeats every minute until the park brake is set.

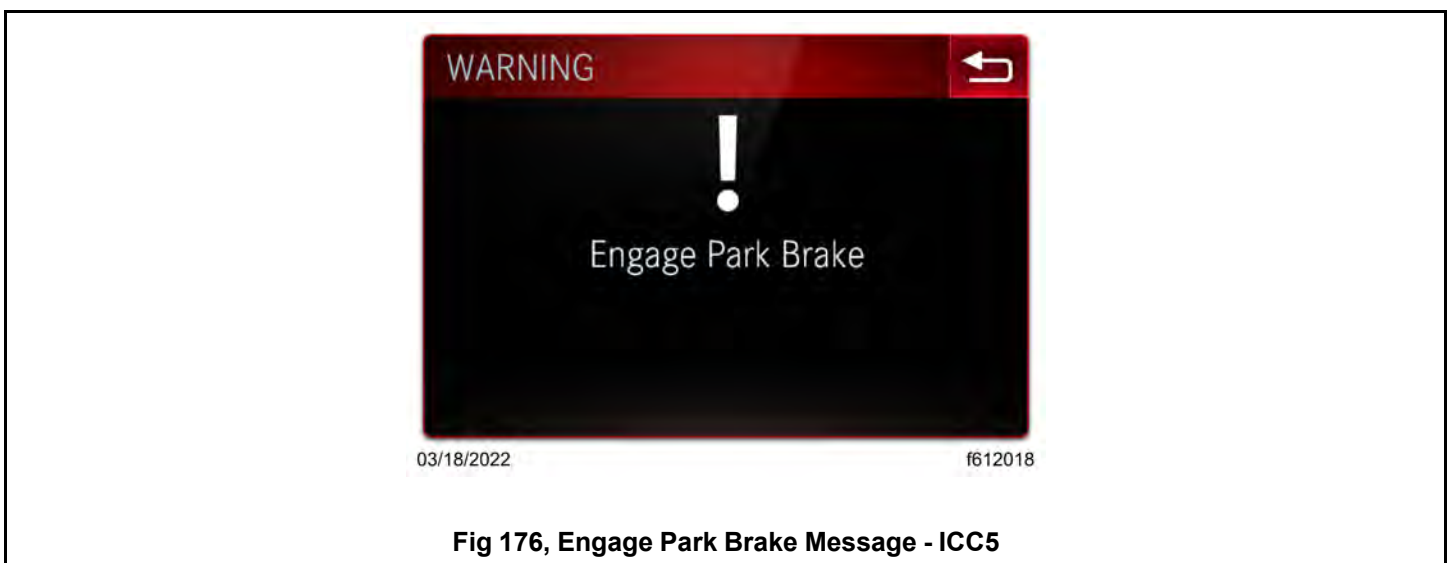

Fig 176, Engage Park Brake Message - ICC5

The same warnings are triggered if the hold function is active and:

- the ignition is turned off without the park brake being set, or
- the brakes are not strong enough to hold the vehicle in place and it starts rolling.

If a door is opened without the park brake being set when the hold function is active, the horn sounds and a visual warning activates on the driver display. If the seat occupancy sensor registers an empty seat under the same conditions, the same warnings are triggered. Warnings cease when the condition that triggered the warning is corrected.

13.06 Air Brake System

13.06.01 General Information

A dual air brake system consists of two independent air systems that use a single set of brake controls. Each system has its own reservoirs, plumbing, and brake chambers. The primary system operates the service brakes on the rear axle; the secondary system operates the service brakes on the front axle. Service brake signals from both systems are sent to the trailer.



WARNING:

Do not operate the vehicle with the front brakes backed off or disconnected. Backing off or disconnecting the front brakes will not improve vehicle handling and may lead to loss of vehicle control, resulting in property damage or personal injury.

Electronic Braking System

The eM2 is equipped with an electronic brake system (EBS). The EBS constantly monitors air pressure and deceleration, actively changing and regulating the air pressure of the brakes regardless of foot position. This allows for the driver to more easily brake on inclines, on declines, and in emergency situations, providing a smoother stop. When using the foot pedal to brake, the EBS analyzes how much the pedal is pressed down and applies the appropriate amount of air to achieve the request of the driver.

The psi of both the primary and secondary system appear on the brake air gauge on the driver display, shown, see Fig. 177, [Brake Air Gauge on Driver Display](#).



Fig 177, Brake Air Gauge on Driver Display

If air pressure drops below approximately 70 psi (483 kPa) in either system, a warning telltale illuminates. See Fig. 178, [Low Brake Air Pressure Telltale](#). If the park brake is not set, an audible alert also activates.

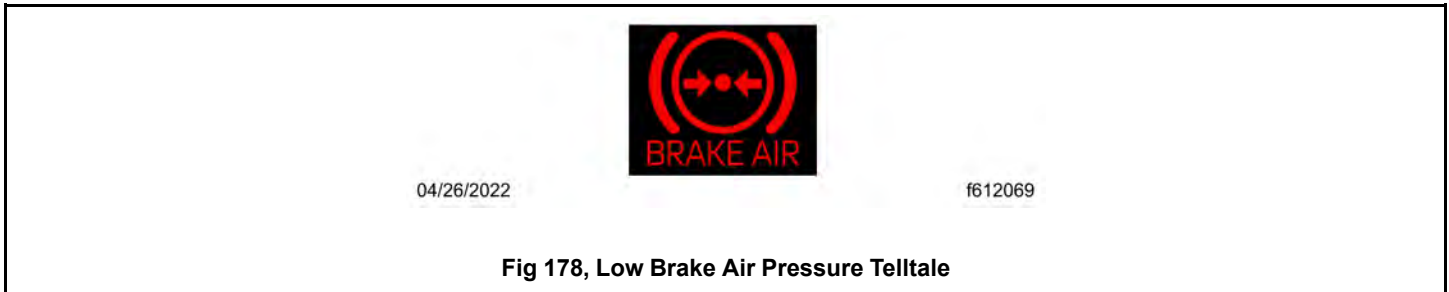

If the low air pressure warning displays, check the air pressure gauges to determine which system has low air pressure. Although the vehicle's speed can be reduced using the foot brake control pedal, either the front or rear service brakes will not be operating at full capacity, causing a longer stopping distance. Bring the vehicle to a safe stop and have the air system repaired before continuing.

IMPORTANT: In the event of a total loss of service brakes with full system air pressure, use the parking brake control valve (yellow knob) to bring the vehicle to a complete stop in the safest location possible.

Before a vehicle with insufficient brake system air pressure can be moved, the spring parking brakes must be released by applying an external air source at the gladhands, or by manually caging the parking brake springs.



WARNING:

Do not cage the spring parking brakes and then drive the vehicle. If you do this, there is no way to hold the vehicle stationary after coming to a complete stop and releasing the service brake pedal. This could result in serious personal injury or vehicle damage. Before releasing the spring parking brakes, make the connection to a towing vehicle or chock the tires.

After correcting the brake system problem, uncage the spring parking brakes before resuming normal vehicle operation.

Primary Air Brake System

Loss of air pressure in the primary air system causes the rear service brakes to become inoperative. The secondary air system continues to operate the front brakes and, if equipped, the trailer brakes.

Secondary Air System

Loss of air pressure in the secondary air system causes the front axle brakes to become inoperative. The primary air system continues to operate the rear service brakes and, if equipped, the trailer brakes.

Electric Air Compressor

The truck is equipped with an electric air compressor and an electric air dryer. These components are sometimes known as an eCompressor and an electronic air processing unit (EAPU). After initial vehicle startup, the driver must wait for the compressor to warm up to operating temperature and then, for the air dryer to clean its desiccant cartridge. The warm up duration may take up to five minutes and is affected by the outside air temperature.

During cleaning cycles, the compressor turns on and off, then the air dryer purges while cycling from cut-in pressure to cut-out pressure, to clean excess contaminants out of the system. Air escaping may be heard coming out of the exhaust port of the EAPU while cleaning.



NOTICE:

If the prior shutdown was performed improperly, on start up, the compressor might cycle several extra times to allow for proper cleaning of the EAPU. In this case, wait for the compressor to finish the additional cleaning cycles. See 12.01.01, page 161, Vehicle Shutdown.

During standard operation, the compressor runs only when the air tanks are at low pressure and no air will be heard exhausting from the EAPU, except while purging.

13.06.02 Air Brake System Operation

Before driving the vehicle, allow time for the air compressor to build up a minimum of 100 psi (689 kPa) pressure in both the primary and secondary systems. Monitor the air pressure system using the dual system air pressure gauge and the low-air-pressure telltale and buzzer. The warning telltale and buzzer shut off when air pressure in both systems reaches 64 to 76 psi (441 to 524 kPa).

IMPORTANT: Before driving the vehicle, secure all loose items in the cab so that they will not fly forward during a full brake application. Make sure all passengers are wearing seat belts.

During normal brake stops, depress the brake pedal until braking action slows down the vehicle. Increase or decrease the pressure on the pedal so that the vehicle comes to a smooth, safe stop. Apply the parking brake if the vehicle is to be parked.

When parking a vehicle attached to a trailer that does not have spring parking brakes, apply the tractor parking brake. Chock the trailer tires before disconnecting the vehicle from the trailer.



WARNING:

If a trailer or combination vehicle is not equipped with spring parking brakes, do not park it by pulling out only the trailer air supply valve knob. This would apply only the trailer service brakes. If air were to bleed from the trailer brake system, the trailer brakes would release, possibly causing an unattended runaway vehicle.



NOTICE:

Never apply the service and spring parking brakes simultaneously. To do so transmits excessive input force to the brake components, which could damage or cause eventual failure of brake actuating components.

Brake Controls

If pressure in both air systems drops to 20 to 45 psi (138 to 310 kPa), the yellow parking brake valve automatically pops out, applying the tractor spring parking brakes.

The yellow diamond-shaped knob in the control panel actuates the parking brake valve. Pulling out the parking brake valve applies the tractor spring parking brake. Pushing in the parking brake valve releases the tractor parking brakes.



05/19/2023

f610291a

Fig 179, Parking Brake Valve Knob

**NOTICE:**

Do not use the spring parking brakes if the service brakes are hot, such as after descending a steep grade. To do so could damage the brakes. Allow hot brakes to cool before using the spring parking brakes.

Do not use the spring parking brakes during freezing temperatures if the service brakes are wet. To do so could cause them to freeze. If the brakes are wet, drive the vehicle in low gear and lightly apply the brakes to heat and dry them.

Moving the lever down applies the trailer brakes, while moving it up releases the trailer brakes.

The valve can be partially or fully applied, but in any partially applied position it will be overridden by a full application of the brake pedal. The lever automatically returns to the up position when it is released.

**WARNING:**

Do not use the trailer service brakes for parking; they are not designed for this purpose. If air bleeds out of the trailer air tank during parking, the vehicle could roll, causing serious personal injury or property damage.

The red octagonal-shaped knob in the control panel actuates the trailer air supply valve. See Fig. 180, [Brake Valve Knobs](#). After the vehicle's air hoses are connected to a trailer and the pressure in both air systems is at least 65 psi (448 kPa), the trailer air supply valve must be pushed in. It should stay in to charge the trailer air supply system and to release the trailer spring parking brakes.

Pull the trailer air supply valve out before disconnecting a trailer.

If pressure in both air systems drops to 20 to 45 psi (138 to 310 kPa), the red trailer air supply valve and yellow parking brake valve automatically pop out, applying both the tractor and trailer spring parking brakes. If the trailer is not equipped with spring parking brakes, the trailer service brakes are applied.

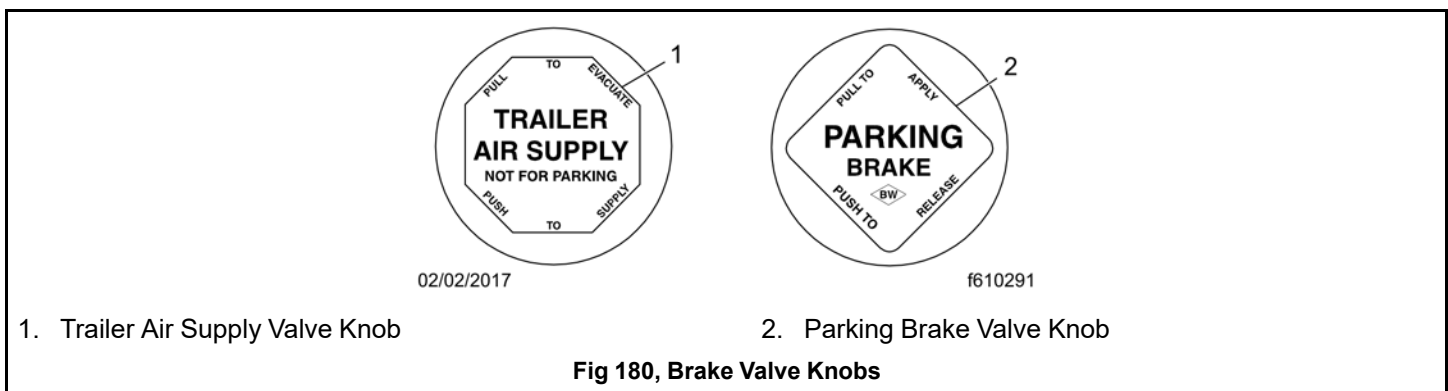

The yellow diamond-shaped knob in the control panel actuates the parking brake valve. See Fig. 180, [Brake Valve Knobs](#). Pulling out the parking brake valve applies both the tractor and trailer spring parking brakes and automatically causes the trailer air supply valve to pop out. Pushing in the parking brake valve releases the tractor parking brakes.

**NOTICE:**

Do not use the spring parking brakes if the service brakes are hot, such as after descending a steep grade. To do so could damage the brakes. Allow hot brakes to cool before using the spring parking brakes.

Do not use the spring parking brakes during freezing temperatures if the service brakes are wet. To do so could cause them to freeze. If the brakes are wet, drive the vehicle in low gear and lightly apply the brakes to heat and dry them.

If the trailer is not equipped with spring parking brakes, pulling out the parking brake valve applies the tractor parking brake and the trailer service brakes. When the tractor and trailer parking brakes (or trailer service brakes) are both applied, the trailer brakes are released by pushing in the trailer air supply valve, leaving the tractor parking brake applied. Air pressure in the primary or secondary reservoir must be at least 65 psi (448 kPa) before the tractor spring parking brakes, or the trailer service or spring parking brakes, can be released.

13.06.03 Automatic Slack Adjusters

Automatic slack adjusters should never be manually adjusted except during routine maintenance of the foundation brakes (such as replacing shoes), during slack adjuster installation, or in an emergency situation.

When the brake pushrod stroke exceeds the legal brake adjustment limit on a vehicle, there is likely a mechanical problem with the foundation brake components or the adjuster is improperly installed.

Visit a repair facility as soon as possible when brakes equipped with automatic slack adjusters are determined to be out of adjustment.

**WARNING:**

Manually adjusting an automatic slack adjuster to bring the pushrod stroke within legal limits is likely masking a mechanical problem. Adjustment is not repairing. Before adjusting an automatic slack adjuster, troubleshoot the foundation brake system and inspect it for worn or damaged components. Improperly maintaining the vehicle braking system may lead to brake failure, resulting in property damage, personal injury, or death.

13.07 ZF™ Antilock Braking System

13.07.01 General Information

IMPORTANT: For proper ABS system operation, do not change tire sizes. The sizes of the tires installed during production are programmed into the electronic control unit. Installing different-sized tires could result in a reduced braking force, leading to longer stopping distances.

The ZF Antilock Braking System (ABS) is an electronic wheel speed monitoring and control system that works with the standard air brake system. ABS passively monitors vehicle wheel speed at all times, and controls wheel speed during emergency stops.

ABS includes signal-generating tone wheels and sensors located in the wheel hubs of each sensed wheel. The sensors transmit vehicle wheel speed information to an electronic control unit, located in the vehicle electronics bay. The control unit's main circuit interprets the speed sensor signals and calculates wheel speed, wheel retardation, and a vehicle reference speed. If the calculations indicate wheel lockup, the main circuit signals the appropriate modulator valve to reduce braking pressure. During emergency braking, the modulator valve alternately reduces, increases, or maintains air pressure supply in the brake chamber to prevent front and rear wheel lockup.

The electronic control unit (ECU) also has a safety circuit that constantly monitors the wheel sensors, traction control valve (if equipped), modulator valves, and the electrical circuitry.

The ZF Antilock Braking System combines one front-axle control channel with one rear-axle control channel to form one control circuit. For example, the sensor and modulator valve on the left-front axle form a control circuit with the sensor and modulator valve on the right-rear axle. If, during vehicle operation, the safety circuit senses a failure in any part of the ABS,

a warning appears on the driver display, the tractor ABS telltale, shown in Fig. 181, [Tractor ABS Telltale](#) illuminates, and the control circuit where the failure occurred is switched to normal braking action. The remaining control circuit retains the ABS effect. Even if the ABS is completely inoperative, normal braking ability is maintained. An exception would be if a modulator valve (or combination modulator valve) is damaged and inoperative. As these components are an integral part of the air brake system, normal braking may be impaired or inoperative.



During emergency or reduced-traction stops, fully depress the brake pedal until the vehicle comes to a safe stop. *Do not pump the brake pedal.* With the brake pedal fully depressed, the ABS controls all wheels to provide steering control and a reduced braking distance. The tractor ABS telltale illuminates when the ABS is engaged.

Although the ZF ABS improves vehicle control during emergency braking situations, it is the driver's responsibility to change driving styles depending on existing traffic and road conditions. For example, the ABS cannot prevent an accident if the driver is speeding or following too closely.

13.08 Automatic Traction Control

Electric vehicles with ABS are equipped with automatic traction control (ATC). On these vehicles, the ATC system automatically limits wheel spin during reduced-traction situations. If the vehicle comes to a stop in soft soil or sand, it may be necessary to back up prior to attempting forward movement.

When the ATC system is in normal mode, it applies gentle braking to the spinning wheel to feed power to the wheel(s) with better traction. If both wheels are spinning, the system signals the motor to reduce power.

If the system detects wheel spin, the wheel spin telltale, shown in Fig. 182, [ATC Active Telltale](#) flashes and an alert is shown on the driver display.

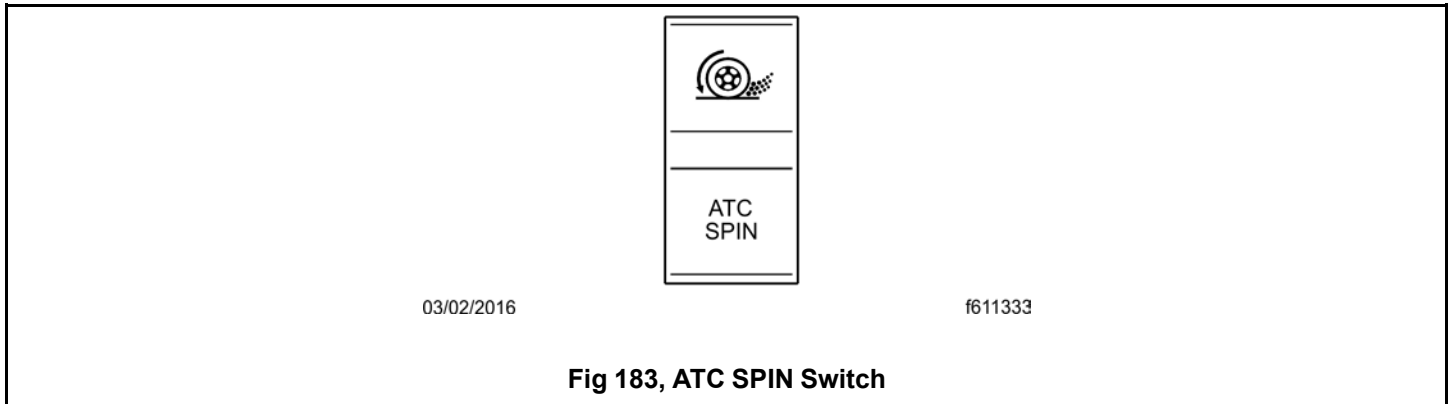

Pressing the ATC SPIN switch, shown in Fig. 183, [ATC SPIN Switch](#) deactivates ATC and allows drive wheel spin. When ATC is off, an ATC deactivated telltale, as shown in Fig. 184, [ATC Deactivated Telltale](#) appears on the driver display. Pressing the switch again, or cycling the keyswitch, cycles the system back to normal operation.

**NOTICE:**

The ATC spin feature is intended to be used under specific slippery conditions that require momentary increased wheel spin. Using this option for an extended period of time may damage the vehicle's brake system.

13.09 Brake and Traction Telltales

Telltales and messages appear on the driver display. The positions of the telltales vary, but most use standard symbols.

The colors of telltales indicate the hazard level as follows: red (warning), amber (caution), green (normal function), blue (active status), grey (passive status), white (informational).

The colors of messages indicate the hazard level as follows: red (warning), amber (caution), grey (informational).

Telltales for braking and traction related features are listed in, see Table.27, [Braking and Traction Telltale Lamps](#). Every vehicle may not be equipped with every feature.











Braking and Traction Telltale Lamps				
Telltale Lamp	Color	Description		Related Information
	Green	Recuperative Braking	Indicates recuperative braking has been activated by moving the right-hand stalk switch into position 1, 2, or 3 (low, medium, or high).	A blue line appears on the charge portion of the power gauge showing the amount of available recuperative braking requested.
	Green	Descent Control Mode	Indicates descent control mode is active.	The driver should always be ready to intervene by applying the service brakes. On steep roads recuperative braking may not be able to maintain the vehicle set speed.
	Amber	Hill Start Aid Disengaged	A blinking telltale indicates hill start aid is off. A solid telltale indicates a fault with the system.	To turn on HSA, press the HSA OFF switch again or cycle the vehicle keyswitch.
	Grey	Brake Hold Mode Engaged	Indicates brake hold mode is active. The service brake is maintained when the driver takes their foot off the brake pedal.	To release the brake hold, press the accelerator pedal, engage the park brake, or rapidly apply and release the brake pedal.
	Red	Park Brake Engaged	Indicates the park brake is engaged.	Always engage the park brake before exiting the vehicle.
	Red	Low Brake Air Pressure	Indicates air pressure in the primary or secondary reservoir has dropped below approximately 70 psi (483 kPa). Bring the vehicle to a safe stop and have the air system repaired before continuing.	A buzzer sounds if the park brake is released or the vehicle is moving when the air pressure is below 70 psi.
	Amber	Tractor Antilock Brake System (ABS)	Momentary illumination indicates the vehicle ABS is engaged. Solid illumination indicates a problem with the vehicle ABS. Repair the ABS to ensure full braking capability.	Even if the ABS is completely inoperative, normal braking ability is maintained.
	Amber	Automatic Traction Control (ATC) Active	A flashing telltale lamp indicates a wheel spin event has been detected, and the ATC system is active.	N/A

Table 27, Braking and Traction Telltale Lamps

Braking and Traction Telltale Lamps				
Telltale Lamp	Color	Description		Related Information
	Amber	Automatic Traction Control (ATC) Deactivated	Indicates the ATC SPIN switch has been pressed to allow wheel slip.	Press the switch again to active ATC.
	Red	Brake System Warning	A solid telltale indicates a failure in the Antilock Braking System/Electronic Braking System (ABS/EBS) or the electronic air processing unit (EAPU). Stop the vehicle and call for service.	N/A

14.01 Power Steering System	212
14.01.01 General Description	212
14.01.02 Cold Activation.....	212
14.01.03 High Temperature Derate and Shutdown	213
14.01.04 Misuse Protection	214

14. Steering System

14.01 Power Steering System

14.01.01 General Description

**NOTICE:**

Never steam clean or high-pressure wash the steering gear. Internal damage to gear seals, and ultimately the steering gear, can result.

**NOTICE:**

Avoid turning the tires when they are against a curb, as this places a heavy load on steering components and could damage them.

The power steering pumps, which are electrically driven, provide power assist for the steering system.

**WARNING:**

Driving the vehicle without the power-assist feature of the steering system requires much greater effort, especially in sharp turns or at low speeds, which could result in an accident and possible injury.

Drivers should carefully use the power available with a power steering system. If the front tires become lodged in a deep hole or rut, drive the vehicle out instead of using the steering system to lift the tires out of the hole.

If the power-assist feature does not work due to hydraulic fluid loss, steering pump damage, or another cause, bring the vehicle to a safe stop. Do not drive the vehicle until the cause of the problem has been corrected.

An error with the power steering system results in the display of this telltale in yellow as shown, see Fig. 185, [Electro-Hydraulic Power Steering Pump Error Telltale](#).

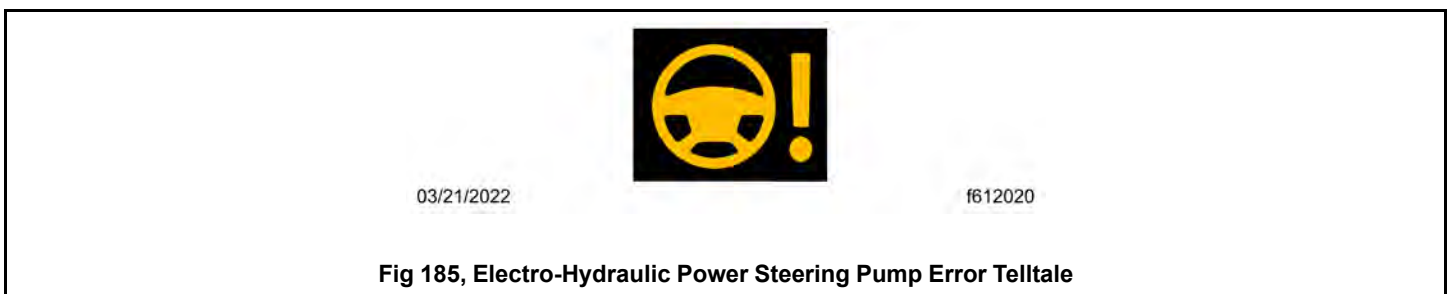

14.01.02 Cold Activation

When the ambient air temperature is below 32°F (0°C), the power steering pumps go into cold activation mode. The driver is notified by the cautionary low temperature window as shown, see Fig. 186, [Cold Activation Notification](#).

In Cold Activation mode the speed of the power steering pumps is limited until the motors warm up. Power steering is available, but steering requires more effort.

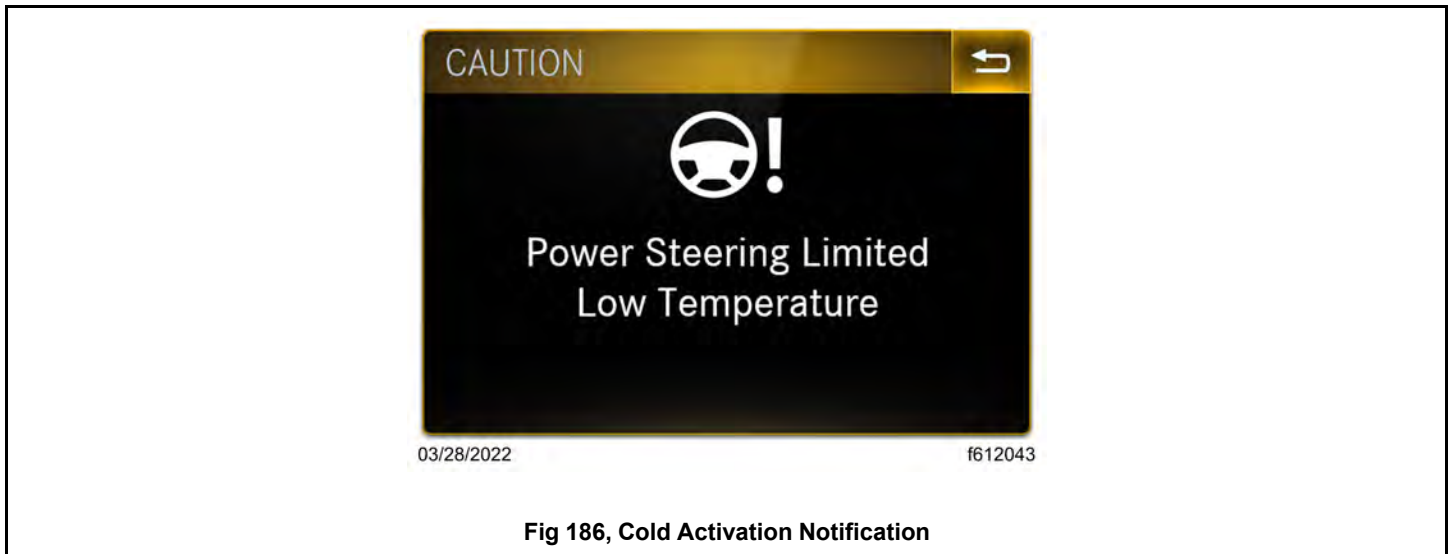

14.01.03 High Temperature Derate and Shutdown

When the power steering pumps experience temperatures over 203°F (95°C), they start to derate. Steering the vehicle takes more effort. A power steering pump derate caution, as shown, see Fig.187, [High Temperature Derate Notification](#) that appears on the driver display.

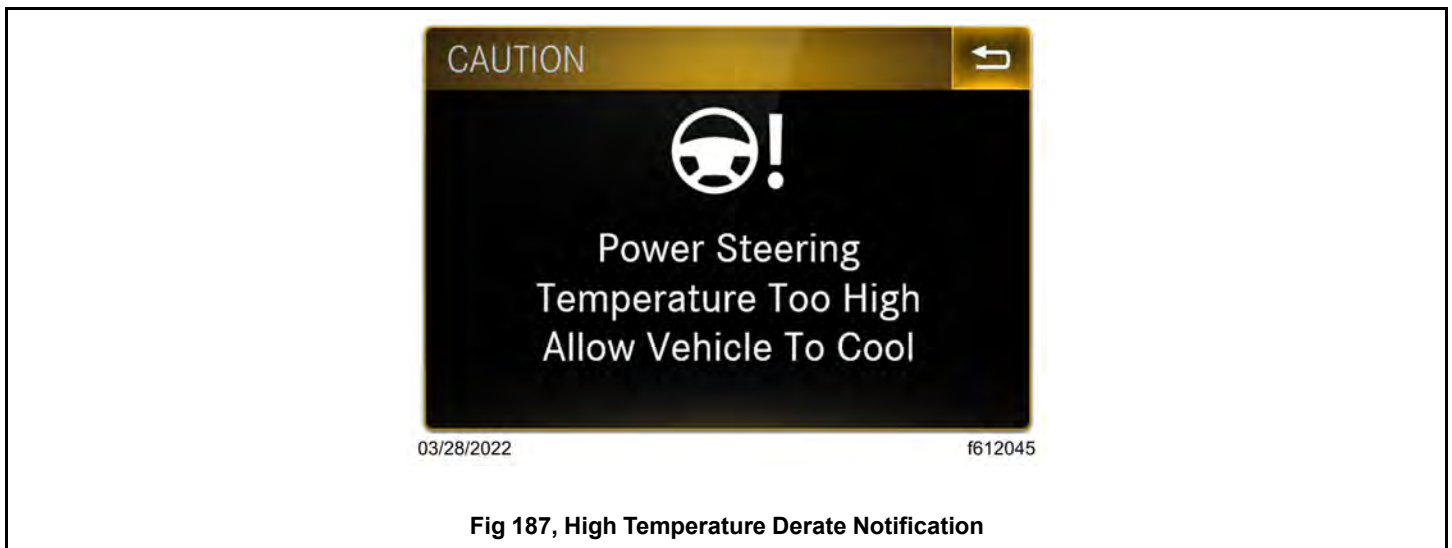

If the power steering pumps reach 230°F (110°C), the pumps will shut down, resulting in a loss of power steering. The driver is notified by a caution window as shown, see Fig.188, [High Temperature Shut Down Notification](#) stating that power steering is not functional.

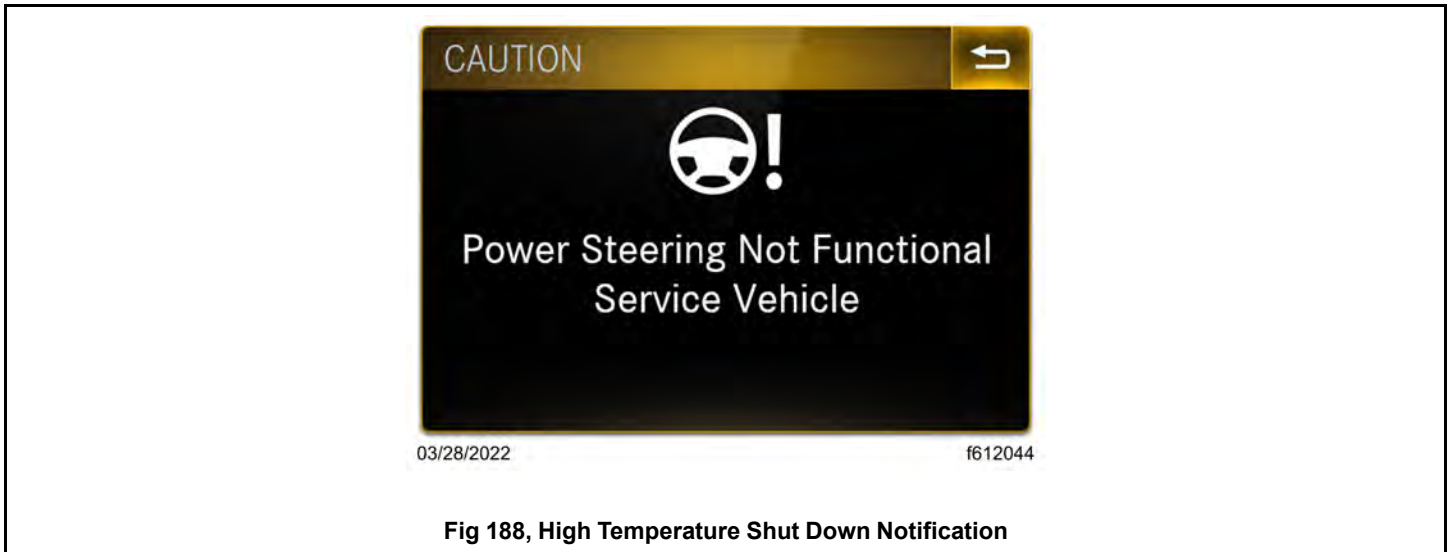

14.01.04 Misuse Protection

Prolonged and aggressive use of power steering that results in a larger current draw by the pumps may cause them to go into misuse protection mode. This limits power steering performance. If this occurs, the power steering malfunction window, as shown see Fig. 189, [Power Steering Malfunction Window](#) appears on the driver display along with the yellow electro-hydraulic power steering error telltale.



15.01 Transmission of the eAxle 2-Speed	216
15.01.01 Gear Display.....	216
15.01.02 Selected Gear.....	216
15.01.03 Recommended Shift	216
15.01.04 Autoneutral.....	216
15.01.05 DCDL Switch and ICU Display	217
15.01.06 DCDL Operation	218

15. eAxle

15.01 Transmission of the eAxle 2-Speed

15.01.01 Gear Display

The current eAxle 2-speed transmission gear and current shift mode are always displayed on the driver display screen. If there is a pending or recommended gear shift, this also appears as shown, see Fig.190, [Current and Pending Gear Display](#).

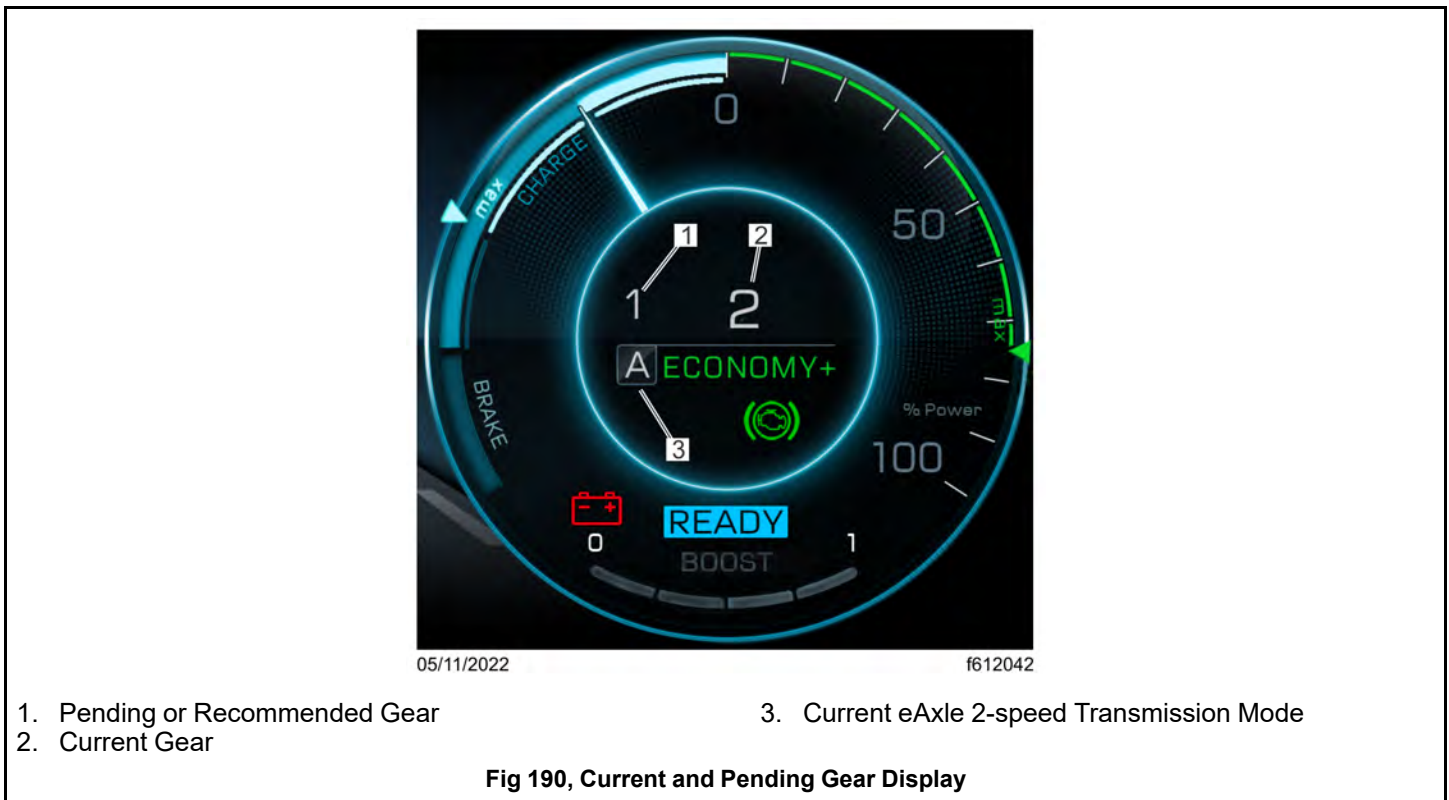

15.01.02 Selected Gear

If the selected gear is different than the recommended gear for longer than a half second, the recommended gear display flashes and the selected gear value is shown. Once the recommended gear and selected gear match, the recommended gear display disappears and the current gear display stops flashing.

15.01.03 Recommended Shift

In Manual mode, a recommended shift is displayed to indicate the most economical gear available.

15.01.04 Autoneutral

Autoneutral automatically shifts the eAxle 2-speed transmission into neutral under certain conditions.

If the vehicle is left in drive or reverse with the park brake applied, after a short period of time a buzzer sounds, the gear display blinks, and a pop up appears. If the driver does not shift the eAxle 2-speed transmission to neutral, the vehicle shifts the eAxle 2-speed transmission to neutral. This change is communicated through a pop up and the eAxle 2-speed transmission mode on the driver display changing to neutral.

If the vehicle is left in drive or reverse with no park brake applied for an extended period of time, the vehicle shifts the eAxle 2-speed transmission to neutral. This change is communicated through a popup and the eAxle 2-speed transmission mode on the driver display changes to neutral.

If the vehicle is left in drive or reverse and the driver turns the keyswitch to off or requests the vehicle power down by other means, a buzzer sounds and the eAxle 2-speed transmission shifts to neutral.

15.01.05 DCDL Switch and ICU Display

The differential lock is activated by a switch on the dash, shown in Fig. , or activated on the Axles screen. The driver-controlled differential lock (DCDL) feature (side-to-side wheel lock, traction control, or traction equalizer) is an option available on eM2 vehicles with single- or tandem-drive axles equipped with a Detroit e-axle.

The DCDL provides maximum traction for slippery conditions by forcing the wheels on each drive axle governed by the switch to rotate together. When the DCDL is engaged, the clutch collar completely locks the differential case, gears, and axle shafts together, maximizing the traction of both wheels.

The axles menu is on the infotainment display accessed by switch 5 as shown, see Fig.

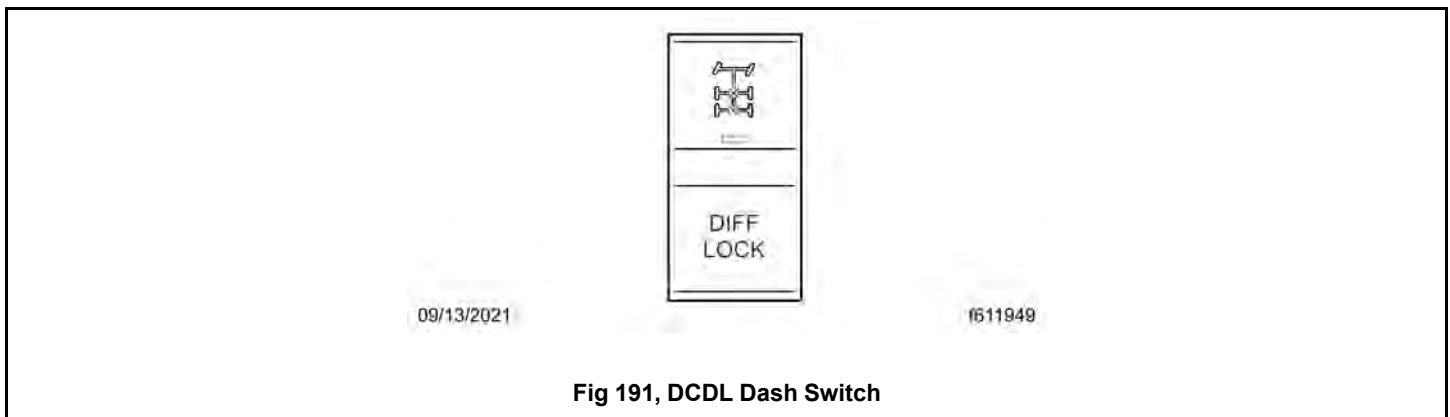

Fig 191, DCDL Dash Switch

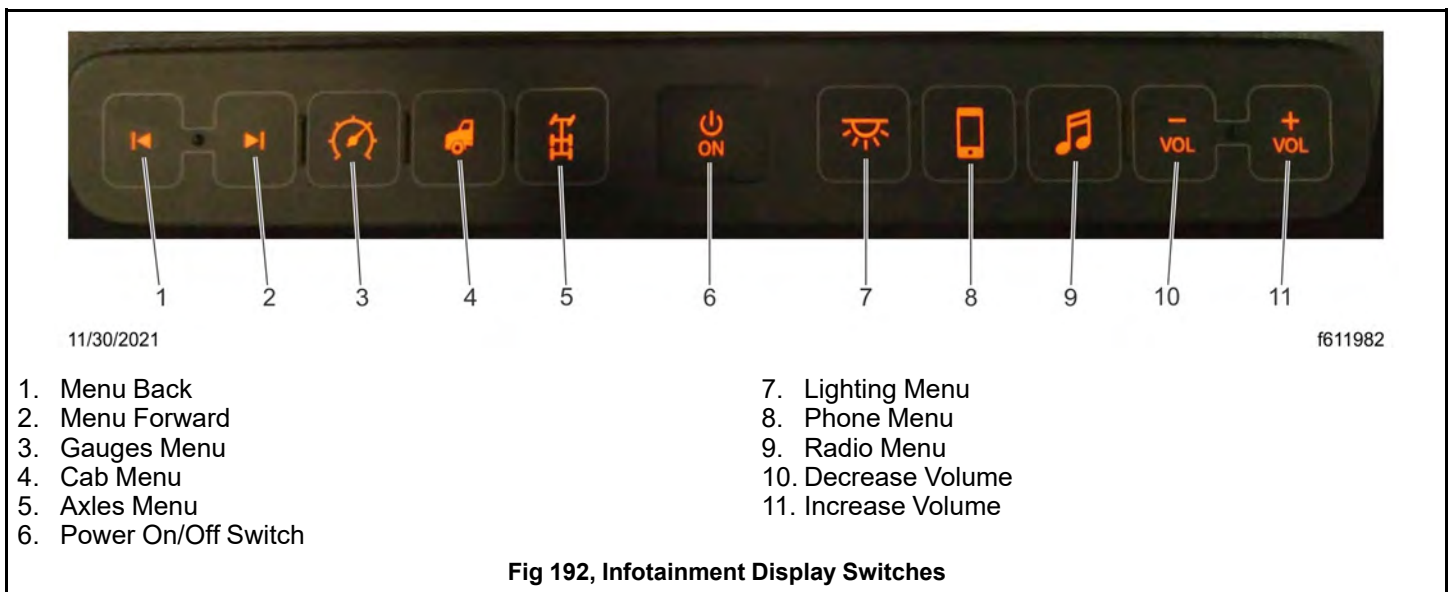
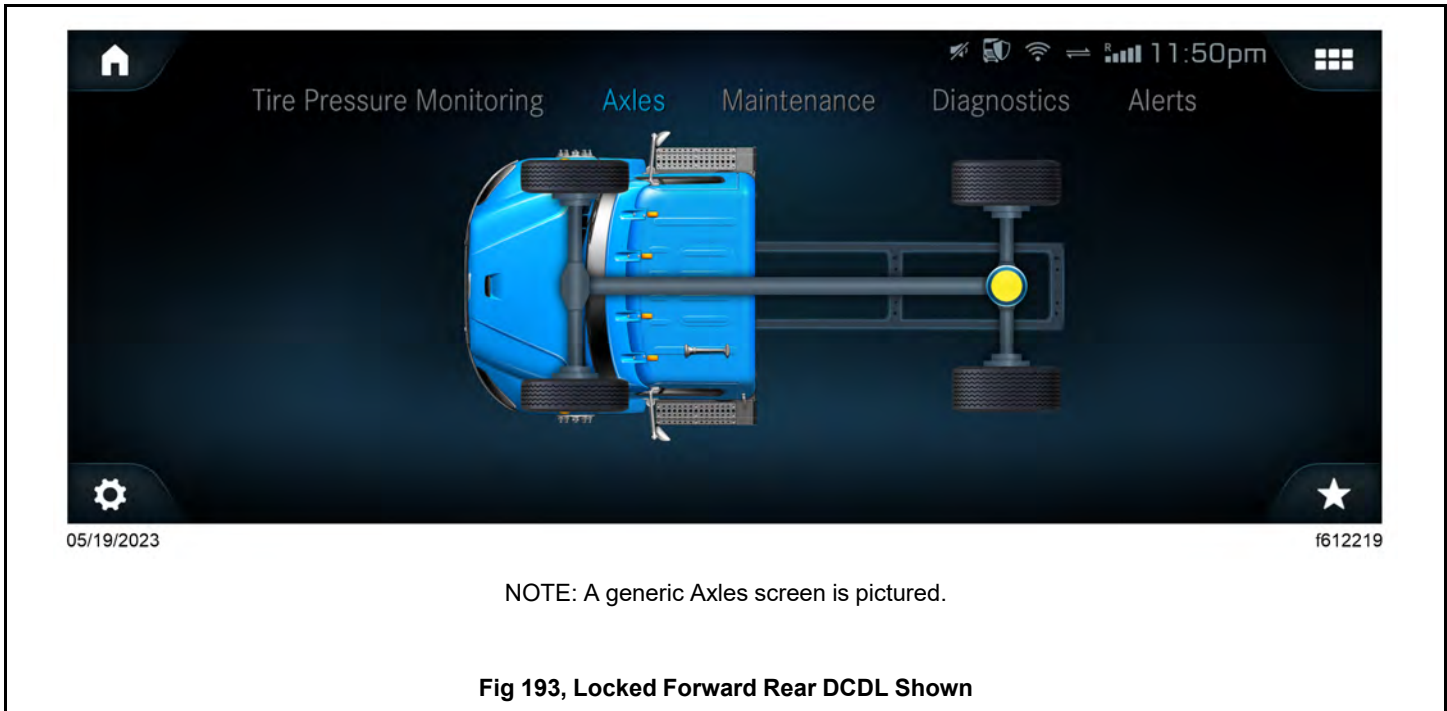

Fig 192, Infotainment Display Switches

The light on the differential lock dash switch illuminates solid amber when the lock is engaged.

Pressing the axle menu switch below the infotainment display calls up the Axles screen showing the axle locks on the vehicle. Unlocked axles display as blue bubbles. Locked axles display as yellow bubbles as shown, see Fig..

Tighten the adjusting nut 50 lbf·ft (68 N·m) while rotating the wheel hub assembly.



The driver can select a blue bubble on the screen to lock that axle. When the lock engages, the blue bubble displays yellow. If the DCDL is engaged when it should not be or not engaged when requested, the amber light on the physical switch and the yellow axle bubble on the infotainment screen flashes.

15.01.06 DCDL Operation



WARNING:

Locking the wheels when the vehicle is traveling down steep grades or when the wheels are slipping could damage the differential and/or lead to loss of vehicle control, causing personal injury and property damage.

IMPORTANT: If equipped with the optional automatic disengagement feature, the DCDL will not engage at speeds above 5 mph (8 km/h) and automatically disengages at 25 mph (40 km/h). The parameters of this feature are not modifiable.



NOTICE:

Engage the DCDL only when the vehicle is stopped or moving at less than 5 mph (8 km/h). Engaging the DCDL at speeds above 5 mph (8 km/h) can cause internal axle damage.

1. With the key ON, press the upper half of the differential lock dash switch or the differential lock bubble on the Axles screen to engage the DCDL.

- If the vehicle is moving, briefly let up on the accelerator to relieve torque on the gears, allowing the differential to fully lock.

The indicator light on the differential lock switch illuminates solid amber and the bubble on the infotainment display illuminates solid yellow when the lock is engaged.



WARNING:

Be especially careful when driving under slippery conditions with the differential locked. Though forward traction is improved, the vehicle can still slip sideways, causing possible loss of vehicle control, personal injury, and property damage.

- Drive cautiously and do not exceed 25 mph (40 km/h). When the differential is fully locked, the turning radius increases because the vehicle under steers. See Fig.194, [Turning Radii](#).

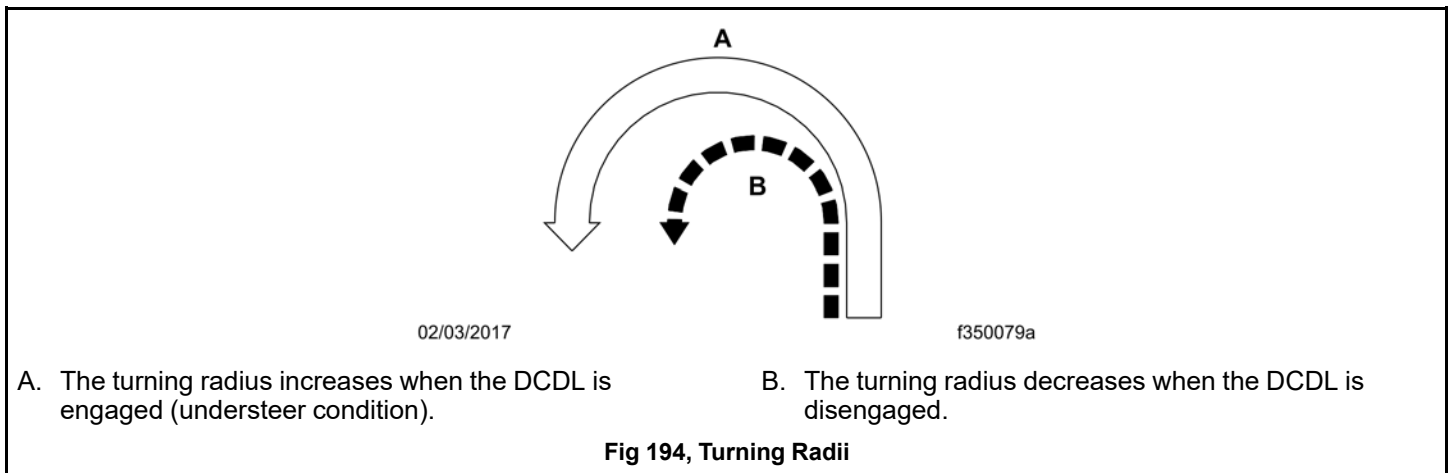

- To disengage the DCDL after leaving poor road conditions, briefly let up on the accelerator to relieve torque on the gears and press the lower half of the differential lock dash switch or select the yellow bubble on the Axles screen in the infotainment display.

When the lock disengages, the indicator light on the switch deactivates and the lock bubble on the Axles screen illuminates blue.

- Resume driving at normal speed.

16.01 Before Checking the Headlight Aim.....	222
16.02 Checking the Aim of the Headlights	222
16.03 Adjusting the Aim of a Headlight	224

16. Headlight Aiming

16.01 Before Checking the Headlight Aim

Do the following before checking or adjusting the headlight aim.

- Clean the headlight lenses. Use a soft cloth with mild, non-caustic soap or detergent, and water.
- Remove any large amounts of mud or ice from the underside of the fenders.
- Check for damage to the hood and hinge assembly. Repair as necessary.
- Check that the hood is closed and latched.
- Check the springs for sagging or broken leaves.
- Check the suspension for proper functioning of the leveling mechanism. On cabs with air suspensions, make sure that the height is properly adjusted.
- With the vehicle unloaded, check that the tires are inflated to the recommended air pressure.

16.02 Checking the Aim of the Headlights

1. Park the vehicle on a level surface 25 ft (7.6 m) away from, and perpendicular to, a vertical screen or wall. Shut down the engine and set the parking brake. Chock the tires.
2. Each headlight has a height adjusting dot on the lens as shown, see Fig. 195, [Headlight](#). Measure the distance from the ground to the height adjusting dot on each headlight as shown see Fig. 196, [Headlight Aiming Screen/Wall](#), ref. A. Make a note of these measurements.

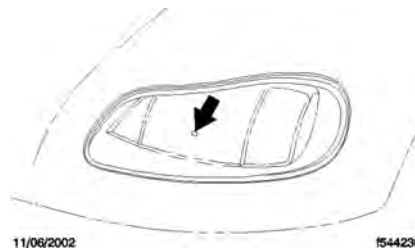

- A. The height adjusting dot is located in front of the low-beam lamp on the headlight lens.

Fig 195, Headlight

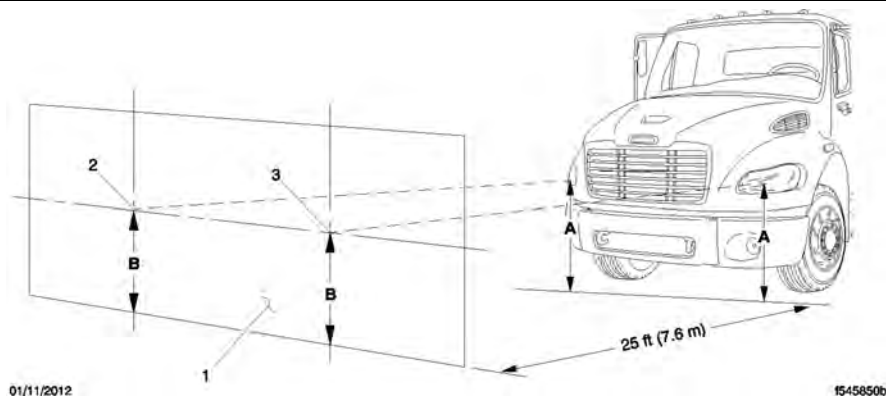

- | | |
|--|---|
| <p>A. Measure the distance from the ground to the center of each headlight bulb.</p> <p>B. Mark where the center of each headlight projection should appear.</p> | <p>1. Screen or Wall</p> <p>2. Center of Right-Hand Headlight Projection</p> <p>3. Center of Left-Hand Headlight Projection</p> |
|--|---|

Fig 196, Headlight Aiming Screen/Wall

3. On the screen or wall, mark the locations of each headlight bulb center using the measurements found in step 2. See Fig.196, [Headlight Aiming Screen/Wall](#), ref. 2 and ref. 3.
4. Turn on the low-beam headlights.
5. Check the vertical adjustment of the low beams. The center of each beam projection should fall on or near the marks made during step 3. See Fig.197, [Vertical Low-Beam Headlight Variation Limits](#).

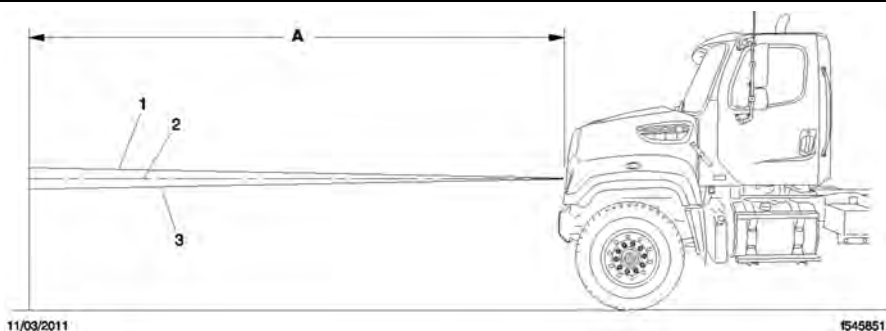

- | | |
|---|--|
| <p>A. Measurement: 25 ft (7.6 m)</p> <p>1. Low-Beam Angle Upper Limit</p> | <p>2. Ideal Low-Beam Projection</p> <p>3. Low-Beam Angle Lower Limit</p> |
|---|--|

Fig 197, Vertical Low-Beam Headlight Variation Limits

6. See Table.28, [Vertical Low-Beam Headlight Variation Limits](#) to determine the maximum vertical distance allowable between the marks on the wall and the center of each low-beam projection.

If the distance between either projection center and the mark made on the wall or screen is greater than the maximum distance as shown, see Table.28, [Vertical Low-Beam Headlight Variation Limits](#) to adjust the vertical positioning of that headlight.

Vertical Low-Beam Headlight Variation Limits			
Distance Between Ground and Headlight: inches (mm)	Desired Variation (see Fig. 197, Vertical Low-Beam Headlight Variation Limits, Item 2): inches (mm)	Upper Limit (see Fig. 197, Vertical Low-Beam Headlight Variation Limits, Item 1): inches (mm)	Lower Limit (see Fig. 197, Vertical Low-Beam Headlight Variation Limits, Item 3): inches (mm)
22–36 (560–900)	0	3.9 (100)	3.9 (100)
36–48 (900–1200)	2 (50) down	2 (50)	6 (150)
48–54 (1200–1400)	4 (101.6) down	1.6 (40)	6.5 (165)

16.03 Adjusting the Aim of a Headlight



NOTICE:

Do not use power tools to adjust headlight aim. Doing so will strip or break the adjusting screw.

The adjusting screw is located on the bottom of the headlight assembly, accessible from inside the wheel well when the hood is closed. See Fig.198, [Headlight Adjusting \(shown with the hood open\)](#).

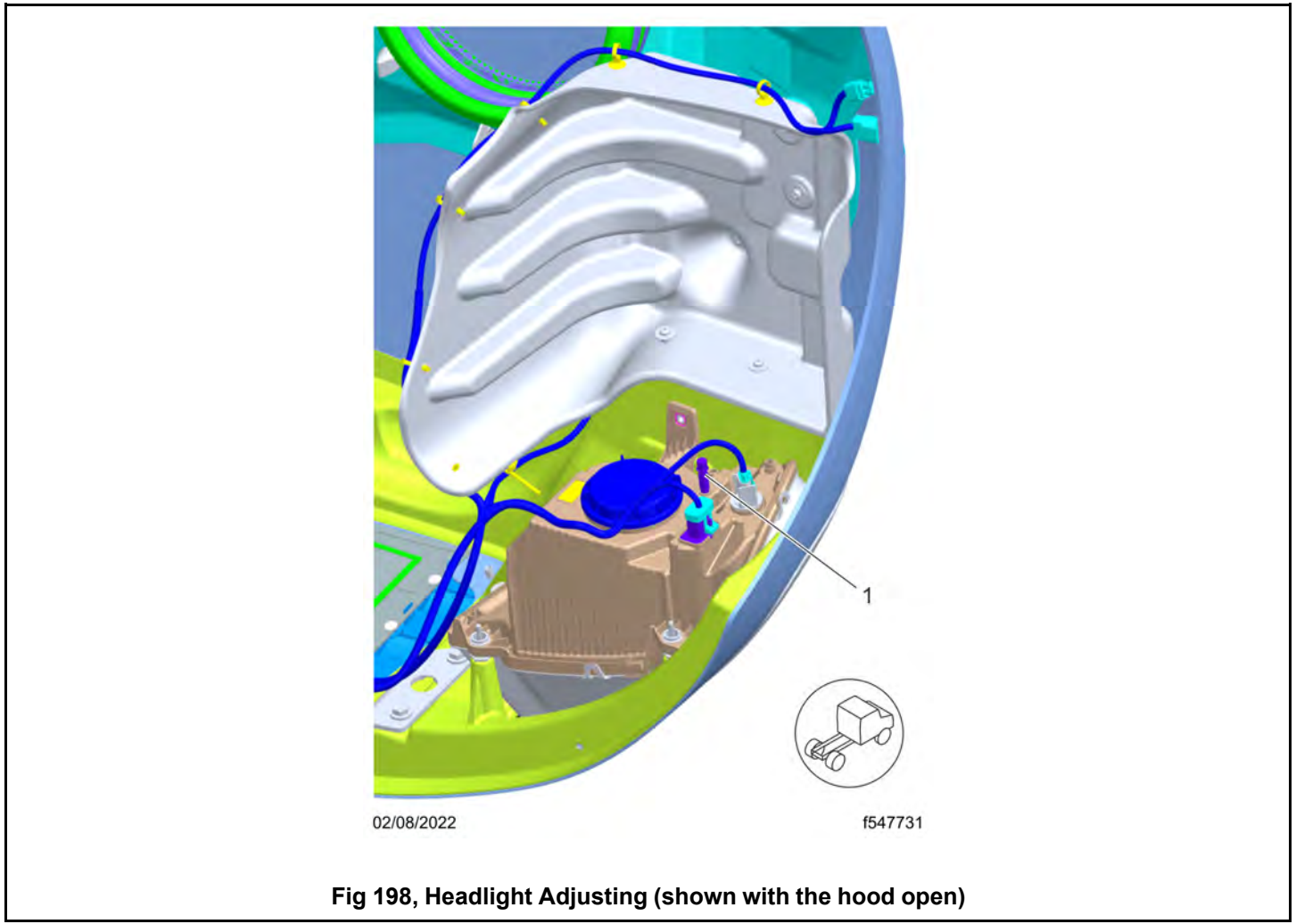

Fig 198, Headlight Adjusting (shown with the hood open)

1. Remove the plug.
2. Turn the adjusting screw clockwise to raise the beam of the headlight or counterclockwise to lower it.
3. Adjust the beam until the center of the low-beam projection and the mark on the wall or screen is within the limits given as shown, see Table.29, [Vertical Low-Beam Headlight Variation Limits](#).

Vertical Low-Beam Headlight Variation Limits			
Distance Between Ground and Headlight: inches (mm)	Desired Variation (Fig. , Item 2): inches (mm)	Upper Limit (Fig. , Item 1): inches (mm)	Lower Limit (Fig. , Item 3): inches (mm)
22–36 (560–900)	0	3.9 (100)	3.9 (100)
36–48 (900–1200)	2 (50) down	2 (50)	6 (150)
48–54 (1200–1400)	4 (101.6) down	1.6 (40)	6.5 (165)

4. If necessary, adjust the other headlight.

17.01 Cleaning and Disinfecting Cab Surfaces.....	228
17.01.01 Cleaning and Disinfecting Safely	228
17.01.02 Cleaning and Disinfecting the High-Touch Surfaces	228
17.01.03 Dashboard and Touch Screen Care	229
17.01.04 Cleaning and Disinfecting Chemicals to Avoid	229
17.02 Cleaning the Cab Floor	230
17.03 Cleaning the Upholstery.....	230
17.03.01 General Information	230
17.03.02 Cleaning Mordura® and Other Cloth Seats	230
17.03.03 Vinyl Upholstery Cleaning	231
17.04 Washing and Polishing the Cab	232
17.04.01 General Guidelines	232
17.04.02 Protecting Your Vehicle's Finish.....	232
17.04.03 Keeping Your Vehicle Looking New	232
17.04.04 Protecting Vehicle Labeling.....	232
17.05 Care of Exterior Lights	233
17.06 Caring for External Chrome Components	233
17.07 Care of Fiberglass Parts	233

17. Vehicle Appearance and Care

17.01 Cleaning and Disinfecting Cab Surfaces

17.01.01 Cleaning and Disinfecting Safely

The following guidelines are for cleaning and disinfecting commonly touched surfaces on the inside and outside of a vehicle.

For best results, follow cleaning and disinfecting procedures fully and consistently. Ensure there is adequate ventilation when using chemicals.

- Doors and windows should remain open when cleaning inside the vehicle.
- When cleaning and disinfecting, individuals should wear disposable gloves compatible with the products being used as well as any other personal protective equipment (PPE) required according to the product manufacturer's instructions and the safety data sheet (SDS).
- Gloves and any other disposable PPE used for cleaning and disinfecting the vehicle should be removed and disposed of after use.
- Wash hands with soap and water for at least 20 seconds immediately after removal of gloves and PPE, or use an alcohol-based hand sanitizer with at least 60 percent alcohol.

17.01.02 Cleaning and Disinfecting the High-Touch Surfaces

NOTE: Depending on how a vehicle is used, it may be helpful to create an inclusive checklist of high-touch surfaces to regularly clean.

To clean surfaces, soak a microfiber cloth with a detergent/water solution, wring the cloth out, and wipe down high-touch areas. Allow the detergent water/solution to sit on the surface for 20-30 seconds before using a fresh microfiber cloth slightly dampened with water to remove it.

After this soap and water wash, Freightliner recommends the use of either a dilutable or ready to use quaternary ammonium based disinfectant on vehicle interior and exterior surfaces.

IMPORTANT: Follow the manufacturer's instructions for using a disinfectant as these vary by product.

**NOTICE:**

Any disinfectant dispensed by a pressurized aerosol container is not recommended. The direct spray of liquids onto the vehicle's interior panels, electronic components, or permeable materials is not recommended.

Using an aerosol disinfecting spray may cause damage to parts of the vehicle.

Examples of either a dilutable or ready to use quaternary ammonium based disinfectant include:

- Lysol® Deodorizing Disinfectant Cleaner
- Fantastik® Disinfectant Multi-Purpose Cleaner
- Hillyard Vindicator®+ Disinfectant

All exterior high-touch surfaces should be cleaned with soap and water before applying disinfectant.

Exterior high-touch surfaces include, but are not limited to, the following:

- grab handles
- door handles
- hood latches and handles

- trailer glad hands

Freightliner recommends applying the disinfectant solution to a microfiber cloth until it is damp but not dripping and then wiping down high-touch areas. Take care to fully wet surfaces with the disinfectant, and ensure that it remains wet for the period of time stipulated by the disinfectant manufacturer to effectively disinfect the surface. Afterwards, if necessary, wipe off excess disinfecting solution with a new clean cloth.

If an interior high-touch surface is visibly dirty, clean it before applying disinfectant; if it appears clean, wipe down the area with disinfectant.

Interior high-touch surfaces include, but are not limited to, the following:

- grab handles
- seats
- arm rests
- steering wheel
- switch pods
- shift knob
- door handles
- seat belt buckles
- light and air controls
- doors and windows

17.01.03 Dashboard and Touch Screen Care

**NOTICE:**

When cleaning the dashboard do not use Armor-All Protectant®, STP Son-of-a-Gun®, window cleaner, or other equivalent treatments. These cleaners contain vinyl plasticizers which can cause stress crazing and cracking in the interior plastic panels. This type of damage is not covered by vehicle warranty.

Wipe down fragile components carefully to avoid damaging the vehicle.

Do not directly spray the screen or any other device in the vehicle. Do not use soap and water on a touch screen. Excess water or disinfectant will damage electrical components.

If the vehicle contains a touch screen, follow the manufacture's instructions for cleaning and disinfecting it. If manufacturer guidance is unavailable, spray a lint-free cloth with a mix of at least 70 percent isopropyl alcohol and distilled water and gently wipe down the screen and then dry it with a clean cloth.

17.01.04 Cleaning and Disinfecting Chemicals to Avoid

Freightliner vehicles should **not** be cleaned or disinfected with products that contain the following chemicals:

- hydrogen peroxide
- sodium chlorite
- sodium hypochlorite (chlorine bleach)
- glycol acid
- octanoic acid
- hypochlorous acid
- silicone

17.02 Cleaning the Cab Floor

Do not pressure wash the cab floor in an electric vehicle.

The supplemental restraint system (SRS)/crash detection equipment located behind the driver's seat as shown, see Fig. 199, [SRS/Crash Detection Equipment Location](#) which should not get wet. When cleaning the cab floor, do not allow any water to come in contact with the SRS/crash detection equipment housing.

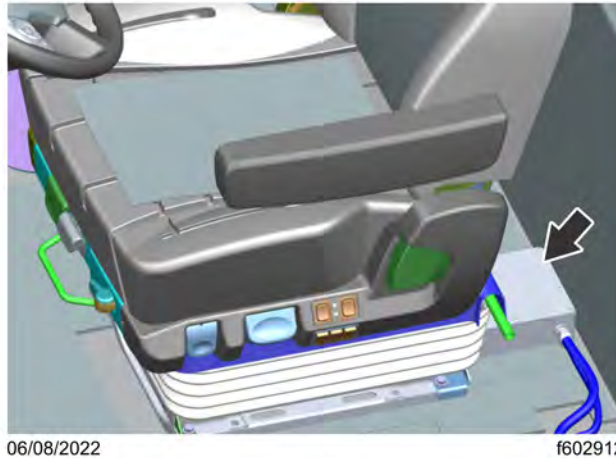

Fig 199, SRS/Crash Detection Equipment Location

17.03 Cleaning the Upholstery

17.03.01 General Information

To prevent soiling, frequent vacuuming or light brushing to remove dust and dirt is recommended. In most cases, quickly wiping down a seat with a damp cloth will remove dirt, spills, and pet hair.

To preserve the upholstery and prevent damage, carefully review the following sections for recommended cleaning procedures.

17.03.02 Cleaning Mordura® and Other Cloth Seats

Vacuuming cloth seats regularly and cleaning spills and stains as soon as they occur and will help keep the seats looking new.

NOTE: Using diluted laundry detergent to clean cloth seats may create excess suds.

Mordura is a highly durable cloth treated with a fire retardant, a Teflon water repellent, and other finishes that prevent color fading and wear. It is the standard cloth used in seats for the eM2.

How to clean a Mordura or other cloth seat:

1. Vacuum the seats to remove loose dirt and debris. Make sure to vacuum the seams where crumbs and debris can gather.
2. Lightly spray a cloth cleaning solution on a soiled or discolored area of the seat.

Don't spray the whole seat. Spray and clean one area before moving onto another.

If the stain has an odor, consider creating a solution of 1/4 cup (60 mL) baking soda and 1 cup (250 mL) of warm water to spray on the stain.

A cleaning solution of 1 cup white distilled vinegar, a few drops of dish soap, and a gallon (4 liters) of hot water may also be used. The smell of the vinegar will dissipate.

Do not saturate the cloth of the seat with any cleaner; soaking a cloth seat may lead to mold or mildew.

3. Using a soft or medium bristle brush, lightly scrub the sprayed area of the seat.
Do not use a stiff bristle brush as it may damage the upholstery.
4. Use a clean microfiber cloth to wipe away suds as they form.
Using a light colored cloth will enable you to see the dirt removed with the suds.
5. Repeat this spray, scrub, wipe process until the area is clean. Stains may take 3 to 7 sprays to remove.
6. Vacuum the seat again to help dry the cloth. Make sure the cloth is completely dry before sitting in the seat.

17.03.03 Vinyl Upholstery Cleaning

Ordinary Dirt

Wash the upholstery with warm water and mild soap, such as saddle or oil soap. Apply soapy water to a large area and let it soak for a few minutes, then rub briskly with a cloth to remove the dirt. This can be repeated several times, as necessary.

If dirt is deeply imbedded, use a soft bristle brush after applying the soap.

If dirt is extremely difficult to remove, wall-washing preparations normally found around the home can be used. Powdered cleaners, such as those used for sinks and tiles, are abrasive and must be used with caution as they can scratch the vinyl or give it a permanent dull appearance.

Chewing Gum

Harden the gum with an ice cube wrapped in a plastic bag, then scrape it off with a dull knife. Any remaining traces of gum can be removed with an all-purpose light oil (peanut butter will also work) and wiped off.

Tars, Asphalts, and Creosote

Each of these items stains vinyl after prolonged contact. They should be wiped off immediately and the area carefully cleaned, using a cloth dampened with naphtha.

Paint, Shoe Heel Marks

Paint should be removed immediately. Do not use paint remover or liquid-type brush cleaner on vinyl. An unprinted cloth, dampened with naphtha or turpentine may be used. Use care to prevent contact with parts of the upholstery that are not vinyl.

Sulfide Stains

Sulfide compounds, such as those found in eggs and some canned goods, can stain after prolonged contact with vinyl. These stains can be removed by placing a clean, unprinted piece of cloth over the spotted area and pouring a liberal amount of 6 percent hydrogen peroxide onto the cloth. Allow the saturated cloth to remain on the spot for 30 to 60 minutes. For stubborn spots, allow the hydrogen-peroxide saturated cloth to remain on the area overnight. Use caution to prevent the solution from seeping into the seams, or it will weaken the cotton thread.

Nail Polish and Nail Polish Remover

Prolonged contact with these substances causes permanent damage to vinyl. Careful blotting immediately after contact minimizes damage. Do not spread the liquid during removal.

Shoe Polish

Most shoe polishes contain dyes which penetrate vinyl and stain it permanently. Shoe polish should be wiped off as quickly as possible using naphtha or lighter fluid. If staining occurs, try the procedure used for sulfide stains.

Ball Point Ink

Ball point ink can sometimes be removed if rubbed immediately with a damp cloth, using water or rubbing alcohol. If this does not work, try the procedure used for sulfide stains.

Miscellaneous

If stains do not respond to any of the treatments described above, it is sometimes helpful to expose the vinyl to direct sunlight for up to 30 hours. Mustard, ball point ink, certain shoe polishes, and dyes often bleach out in direct sunlight, leaving the vinyl undamaged.

17.04 Washing and Polishing the Cab

17.04.01 General Guidelines

IMPORTANT: Carefully read all instructions before using or applying any cleaner or product on the vehicle or components. Failure to follow manufacturers' recommendations can result in damage to the finish.

**WARNING:**

Do not power wash or steam clean in the area of vehicle electrical components, unless specified by vehicle manuals or service literature. Power washing and steam cleaning can cause corrosion, permanently damaging these components, which could result in fire, personal injury, or property damage.

17.04.02 Protecting Your Vehicle's Finish

To protect the finish of your new vehicle, follow these guidelines carefully.

- During the first 30 days, rinse your vehicle frequently with water. If the vehicle is dirty, use a mild liquid soap. Do not use detergent.
- During the first 30 days, do not use anything abrasive on your vehicle. Brushes, chemicals, and cleaners may scratch the finish.
- During the first 120 days, do not wax your vehicle.

17.04.03 Keeping Your Vehicle Looking New

To extend the life of your vehicle's finish, follow these guidelines:

- Avoid washing your vehicle in the hot sun.
- Always use water. After the cab is completely washed, dry it with a towel or chamois.
- Do not dust painted surfaces with a dry cloth, as this will scratch the paint.
- Do not remove ice or snow from a painted surface with a scraper of any sort.
- To prevent damage to the finish, wax it regularly. Before waxing, if the finish has become dull, remove oxidized paint using a cleaner specifically designed for this purpose. Remove all road tar and tree sap before waxing. Freightliner recommends that a quality brand of cleaner or cleaner-polish and polishing wax be used.
- Do not let antifreeze stand on a painted surface. If this should occur, rinse the surface off with water.
- To prevent rust, have any nicks or other damage on the finish touched up as soon as possible.
- Park your vehicle in a sheltered area whenever possible.

17.04.04 Protecting Vehicle Labeling

A majority of the labels applied to cab are required for reasons of safety or identification. To prevent delamination and deterioration of labels and stickers, follow these guidelines carefully:

- Do not pressure wash the label or sticker or surfaces near it.
- Do not use strong alkaline soaps on or near the label or sticker.

17.05 Care of Exterior Lights

**NOTICE:**

Do not use a power buffer, paper towels, chemical solvents, or abrasive cleaners on the headlight lens, all of which can remove the UV coating from the surface, and result in yellowing of the lens.

Clean the headlight lenses by hand only, using a flannel cloth with mild, non-caustic soap or detergent, and water.

17.06 Caring for External Chrome Components

NOTE: Chrome components are optional on the eM2.

To prevent rust, keep chrome parts clean and protected at all times. This is especially important during winter driving and in coastal areas where there is exposure to salt air.

When cleaning chrome parts, use clean water and a soft cloth or sponge. A mild detergent may also be used.

Sponge gently, then rinse. If necessary, use a non-abrasive chrome cleaner to remove stubborn rust or other material. Do not use steel wool.

To help protect the chrome after cleaning, apply a coat of polishing wax to the surface. Never use wax on parts that are exposed to high heat, such as exhaust pipes.

17.07 Care of Fiberglass Parts

Wash any fiberglass components monthly with a mild detergent, such as dishwashing liquid. Avoid strong alkaline cleansers.

Apply a wax specifically designed for fiberglass.

18.01 Periodic Inspections and Maintenance, General Information	236
18.02 Checklists	236
18.02.01 Daily Pre-Trip Inspection Checklists	236
18.02.02 Weekly Post-Trip Inspection Checklist	238
18.02.03 Monthly Post-Trip Inspection Checklists	238
18.03 Fluids Added	239

18. Pre- and Post-Trip Checklists

18.01 Periodic Inspections and Maintenance, General Information

It is the driver's responsibility to inspect the vehicle and ensure it is completely roadworthy before placing it into service.

Commercial vehicles may be subject to inspection by authorized inspectors; an unsafe vehicle can be taken out of service until the driver or owner repairs it.

Use the following checklists to ensure that vehicle components are in good working condition before each trip. Careful inspections eliminate downtime to fix overlooked or forgotten items.

The checklists in this chapter can be copied and kept as a record that the procedures have been completed. For details on how to inspect each item on the checklists, see the corresponding procedure (step number) in see [18.01 Periodic Inspections and Maintenance, General Information](#).

18.02 Checklists

18.02.01 Daily Pre-Trip Inspection Checklists

NOTE: Checklists in this chapter correspond with the procedures and steps in see [18.01 Periodic Inspections and Maintenance, General Information](#), [Pre- and Post-Trip Inspections and Maintenance](#). Your vehicle may not be equipped with all components listed below.

See the following tables for a list of procedures that should be performed daily, before the first trip. Place a check mark in the **Done** column to indicate a procedure has been performed.

Inspector	Date

Suspension and Slack Adjusters Inspection		Done
1	Inspect suspension components.	
2	Inspect slack adjusters.	

Inspection of Wheels and Tires		Done
1	Inspect wheel covers.	
2	Examine tire condition.	
3	Check tire inflation.	
4	Examine and clean rims and wheel components.	
5	Inspect wheel bearing oil seals and lubrication levels.	
6	Check mud flaps.	

Mid-Frame Area Inspection		Done
1	Drain brake system air reservoirs on vehicles without automatic drain valves.	
2	Inspect frame rails and crossmembers.	

Front Box Inspection		Done
1	Check for oil leaks.	
2	Check for coolant leaks.	
3	Check power steering reservoir fluid level.	
4	Check eDrive surge tank coolant levels.	
5	Check battery surge tank coolant levels.	
6	Inspect visible wiring.	
7	Inspect frame rails.	

Cab Inspection		Done
1	Check the air pressure warning systems.	
2	Check the air governor cut-in and cut-out pressures.	
3	Check the air pressure build-up time.	
4	Check the air system leakage.	
5	Check the air pressure reserve.	
6	Inspect mirrors, windows, and windshield.	
7	Ensure the horn, windshield wipers, and windshield washers are working properly.	
8	Verify heater and defroster are working properly.	
9	Check the operation of all interior lamps	
10	Check the operation of all exterior lamps.	
13	Inspect all seat belts and tether belts.	
14	Make necessary mirror adjustments.	
15	Test the service brakes.	

Cab Inspection		Done
16	Test the backup beep.	
17	Test the gas detection system.	

18.02.02 Weekly Post-Trip Inspection Checklist

NOTE: Checklists in this chapter correspond with the procedures and steps in see [18.01 Periodic Inspections and Maintenance, General Information, Pre- and Post-Trip Inspections and Maintenance](#). Your vehicle may not be equipped with all components listed below.

See the following table for procedures that should be performed weekly, post-trip. Place a check mark in the **Done** column to indicate a procedure has been performed.

Inspector	Date

Front Box Inspection		Done
2	Check the windshield washer reservoir level.	
3	Inspect all water evacuation components.	
4	Inspect air vent hoses.	
5	Inspect the steering components.	

18.02.03 Monthly Post-Trip Inspection Checklists

NOTE: Checklists in this chapter correspond with the procedures and steps in see [18.01 Periodic Inspections and Maintenance, General Information, Pre- and Post-Trip Inspections and Maintenance](#). Your vehicle may not be equipped with all components listed below.

See the following tables for procedures that should be performed monthly, post-trip. Place a check mark in the **Done** column to indicate a procedure has been performed.

Inspector	Date

Brake Components		Done
1	Inspect brake system component fasteners.	
2	Inspect brake chamber exterior surfaces.	
3	Inspect air brake lines.	

Brake Components		Done
4	Inspect flex air lines.	
5	Inspect brake linings and brake drums/rotors.	
6	Check thickness of brake linings.	

eAxle	
1	Inspect rear pads.
2	Inspect bolts on mounting brackets.

Mid-Frame Area		Done
1	Drain brake system air reservoirs on vehicles without automatic drain valves.	
2	Inspect aerodynamic components.	

Front Box Inspection		Done.
1	Inspect the hood and bumper.	
2	Inspect radiator and heater hoses.	
3	Inspect the low-voltage batteries.	
4	Check the steering wheel for excessive play.	

18.03 Fluids Added

Use the following table to note any fluids that were added during the inspection and maintenance procedures.

Fluids Added During Inspection	
Fluid	Amount Added
Wheel hub oil	
Power steering fluid	
eDrive coolant	
Windshield washer fluid	
Battery circuit coolant	

19.01 Safety Precautions	242
19.02 Daily Pre-Trip Inspections and Maintenance	242
19.02.01 General Description	242
19.02.02 Suspension and Slack Adjuster Inspection	242
19.02.03 Wheel and Tire Inspection	243
19.02.04 Mid-Frame Area Inspection	246
19.02.05 Front Box Inspection	246
19.02.06 Inspection of the Cab	248
19.03 Weekly Post-Trip Inspections and Maintenance	254
19.03.01 Inspection of the Front Box	254
19.04 Monthly Post-Trip Inspections and Maintenance	255
19.04.01 Inspection of the Brake Component	255
19.04.02 Inspection of the eAxle	256
19.04.03 Inspection of the Mid-Frame Area	257
19.04.04 Inspection and Adjustments of the Front Box	257

19. Pre- and Post-Trip Inspections and Maintenance

19.01 Safety Precautions

**DANGER:**

When working on the vehicle, turn the key to the off position, set the parking brake, and chock the tires.

Before working on the high-voltage (HV) system, decommission the vehicle and verify the HV system is shut down

Before working under the vehicle, always place jack stands under the frame rails to ensure the vehicle cannot drop.

Failure to follow these directions could result in serious personal injury or death.

19.02 Daily Pre-Trip Inspections and Maintenance

19.02.01 General Description

Complete the following inspection and maintenance procedures to ensure that vehicle components are in good working condition before each trip. A driver who is familiar with the vehicle and drives it regularly can perform the daily inspections, then add the weekly and monthly post-trip inspections as scheduled.

If the driver does not operate the vehicle on a consistent basis, all daily, weekly, and monthly inspection and maintenance procedures should be performed before the trip.

IMPORTANT: The pre- and post-trip checklists, inspections, and maintenance procedures detailed in this chapter are **not all-inclusive**. Refer to other component and body manufacturers' instructions for specific inspection and maintenance instructions, as well as local, state, and federal guidelines.

NOTE: If any system or component does not pass this inspection, it must be corrected before operating the vehicle. Whenever equipment requires adjustment, replacement, and/or repair, see the **eM2 Workshop Manual** for procedures and specifications.

19.02.02 Suspension and Slack Adjuster Inspection

Walk around the vehicle and visually inspect suspension and slack adjuster components.

1. Inspect the following suspension components for signs of structural damage, cracks, or wear.
 - springs
 - spring hangers
 - shocks
 - suspension arms
 - suspension brackets
 - axle seats
 - bushings
2. Inspect slack adjusters for signs of damage. See Fig.200, [Meritor Automatic Slack Adjuster](#).

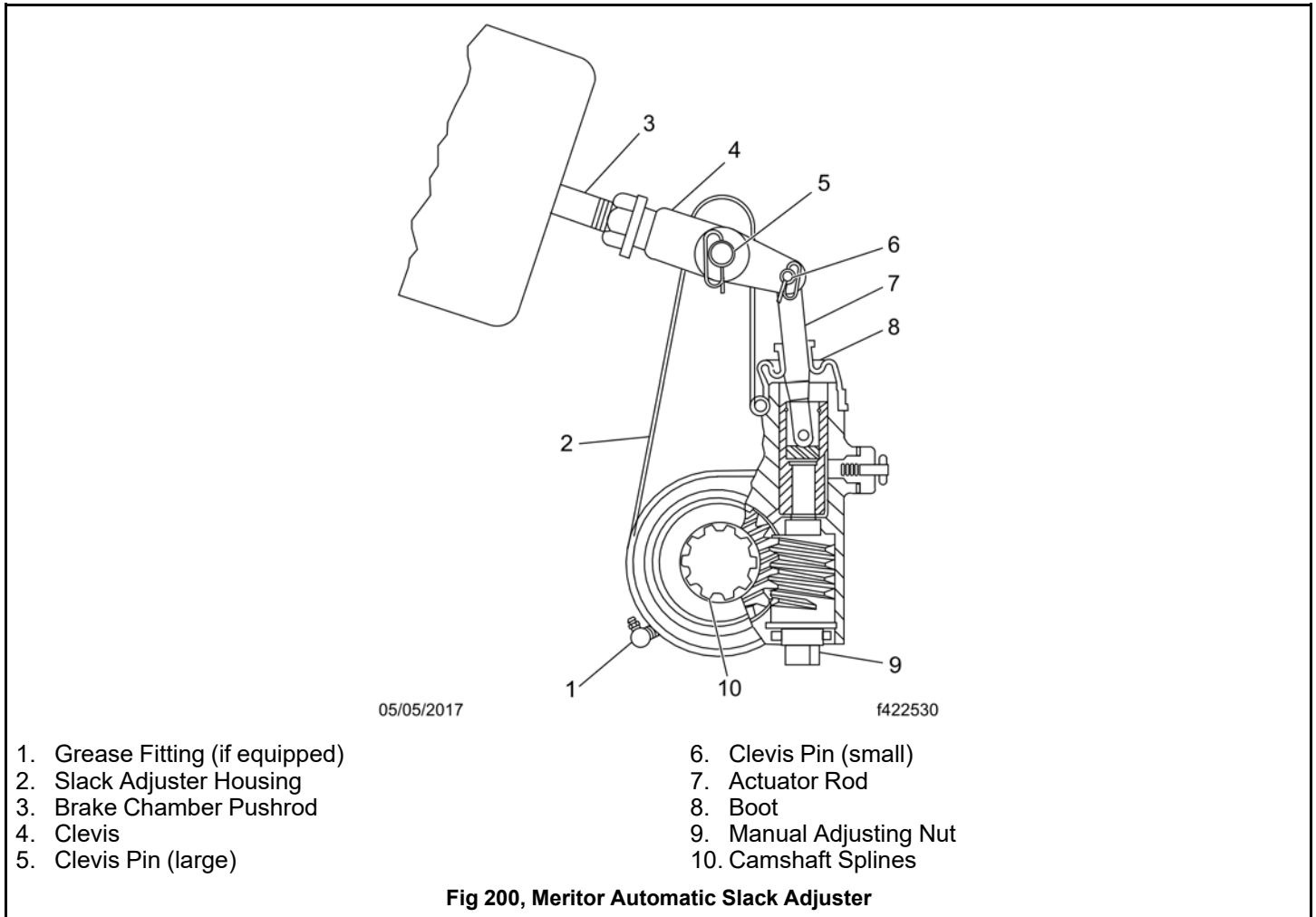

- Inspect slack adjuster boots for cuts or tears.
- Look for worn clevis pins on brake chamber pushrods.
- Look for missing or damaged cotter pins on the clevis pins.
- Ensure chamber piston rods are in line with the slack adjusters.

19.02.03 Wheel and Tire Inspection

Walk around the vehicle and visually inspect each wheel and tire assembly.

IMPORTANT: Wheel covers decrease drag force as a vehicle moves, thereby improving fuel efficiency. If replacement of a wheel cover is necessary, the replacement cover must meet or exceed the drag reduction performance of the originally installed cover in order to maintain compliance with greenhouse gas and fuel efficiency regulations.

1. If the vehicle was originally equipped with wheel covers, ensure all wheel covers are present and inspect them for damage or wear.
If equipped, remove the wheel covers from rear drive wheels prior to inspecting the tires and wheel components.

NOTE: To install a wheel cover, align the center cover opening on the cover support bracket and rotate 60 degrees until the cover latches.

2. Inspect each tire for the following:

- valve stem caps on every tire, screwed on finger-tight
- bulges, cracks, cuts, and penetrations
- oil contamination (petroleum derivatives will soften the rubber and destroy the tire)
- tread depth—if tread is less than 4/32 inch (3 mm) on any front tire, or less than 2/32 inch (1.5 mm) on any rear tire, replace the tire
- debris lodged between dual tire sets

IMPORTANT: Low-rolling resistance (LRR) tires minimize wasted energy as a tire rolls, thereby decreasing rolling effort and improving fuel efficiency. If tire replacement is necessary, replacement tires must meet or have less rolling resistance than the originally installed tires in order to maintain compliance with greenhouse gas and fuel efficiency regulations. Contact your tire manufacturer/supplier to determine the rolling resistance of the originally installed tires. Visit www.epa.gov/smartway for additional information and resources.

3. Check tire inflation.

For inflation pressures and maximum loads, see the tire manufacturer's guidelines. Inflate the tires to the applicable pressures if needed.

If a tire has been run flat or under-inflated, check the wheel and tire for damage before adding air.

Keep compressed air reservoirs and lines dry during tire inflation. Use well-maintained inline moisture traps and service them regularly.

**WARNING:**

Do not operate the vehicle with underinflated or overinflated tires. Incorrect inflation can stress the tires and make the tires and rims more susceptible to damage, possibly leading to rim or tire failure and loss of vehicle control, resulting in serious personal injury or death.

IMPORTANT: The load and cold inflation pressure must not exceed the rim or wheel manufacturer's recommendations, even though the tire may be approved for a higher load inflation. Consult the rim or wheel manufacturer for the correct tire inflation pressure for the vehicle load.

**NOTICE:**

A weekly pressure loss of 4 psi (28 kPa) or more in a tire may indicate damage. The tire should be inspected and, if necessary, repaired or replaced by a qualified tire service facility.

4. Examine each rim and wheel component.
 - 4.a Remove all dirt and debris from the assembly. Rust streaks or metal build-up around stud holes, or out-of-round or worn stud holes, may be caused by loose wheel nuts.

**WARNING:**

Have any worn or damaged wheel components replaced by a qualified person using the wheel manufacturer's instructions and the wheel industry's standard safety precautions and equipment. Otherwise a vehicle or workshop accident could occur, possibly resulting in serious personal injury or death.

- 4.b Inspect for broken, cracked, badly worn, bent, rusty, or sprung rings and rims.

**NOTICE:**

Use the recommended torque values and follow the proper tightening sequence. Insufficient wheel nut torque can cause wheel shimmy, resulting in wheel damage, stud breakage, and extreme tire tread wear. Excessive wheel nut torque can break studs, damage threads, and crack discs in the stud hole area.

- 4.c Make sure all wheel nuts are tightened. If tightening is necessary, use the tightening pattern, see Fig. 201, [Tightening Pattern, 10-Hole Wheels](#) to initially tighten the flange nuts 50 to 100 lbf·ft (68 to 136 N·m). Then tighten the flange nuts 450 to 500 lbf·ft (610 to 678 N·m).

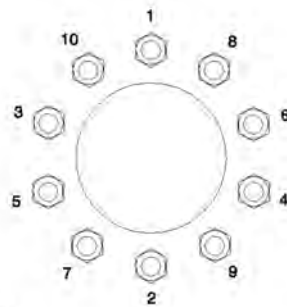

Fig 201, Tightening Pattern, 10-Hole Wheels

5. Inspect the outboard side of all wheel hubs and the hub oil seal area on the inboard side of each wheel for signs of oil leakage. If any oil is found on wheel and tire or brake components, remove the vehicle from service until the leak has been fixed.

If needed, fill the hubs to the level indicated on the hub cap. See **Group 35** of the **eM2 Maintenance Manual** for recommended lubricants.

6. Check that mud flaps are undamaged and hang 10 inches (25.4 cm) or less from the ground.

19.02.04 Mid-Frame Area Inspection



WARNING:

When draining the air reservoir, do not look into the air jets or direct them toward anyone. Dirt or sludge particles may be in the airstream and could cause injury.



NOTICE:

If the water drained from the air reservoirs is cloudy or oily, it may indicate a problem with the compressor. If oil is allowed to contaminate the air dryer, it will not remove the water from the air brake system, which could adversely affect braking.

1. On vehicles without automatic drains, drain the brake system air reservoirs.
2. Inspect visible frame rails for missing bolts, shiny areas, or rust streaks. Check all visible crossmembers for damage or signs of looseness.

19.02.05 Front Box Inspection

1. Check the ground underneath the front box for oil leaks.
2. Check the ground underneath the front box and along the chassis for coolant leaks.
3. Open the hood.

Check the power steering reservoir fluid level.

The power steering fluid level should be between the MIN COLD mark and the middle mark just above it. See Fig. 202, [Power Steering Fluid Reservoir](#).

If needed, fill the reservoir with automatic transmission fluid that meets Dexron III or TES-389 specifications.

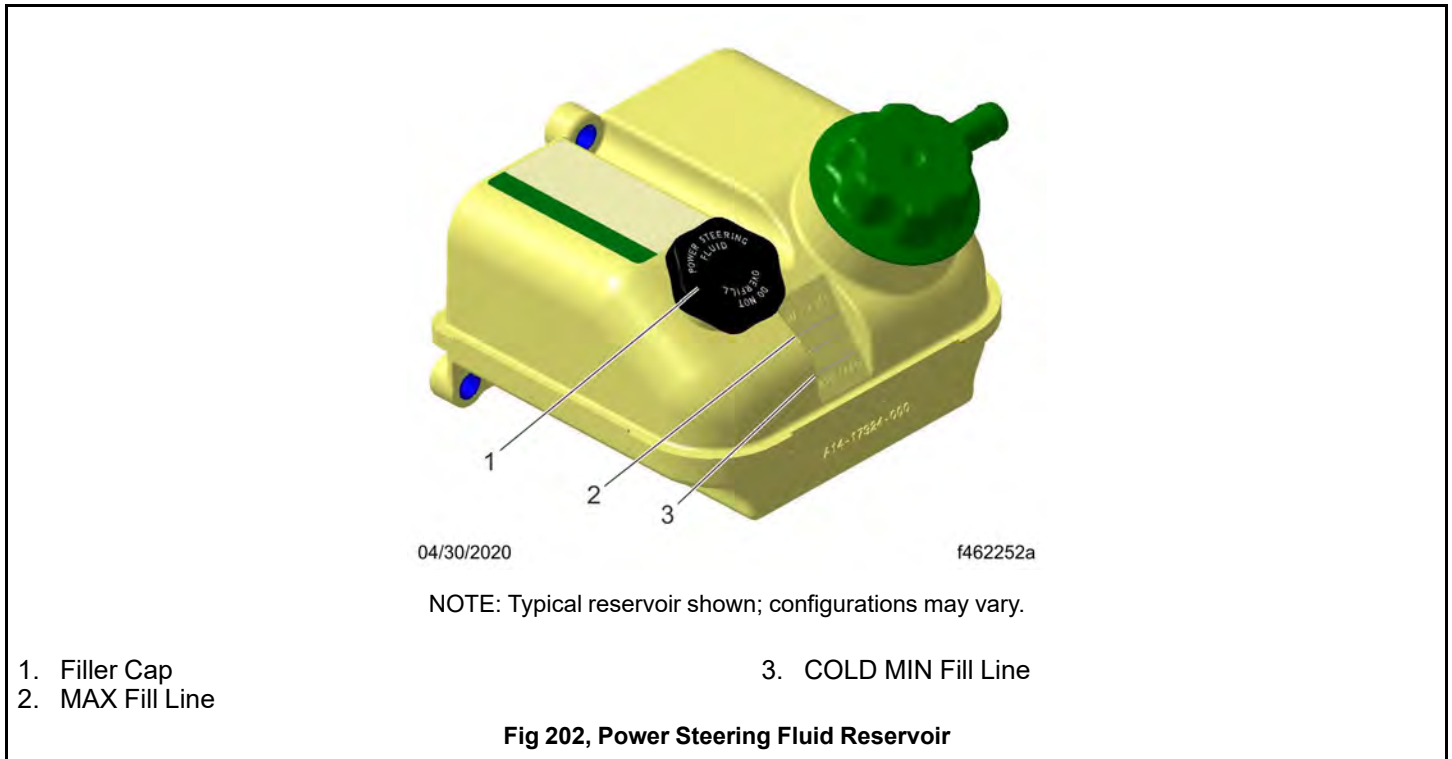

IMPORTANT: The surge tanks must be cool to check the coolant levels.



NOTICE:

Coolant must be filled to the COLD MAX line of the surge tanks. Low coolant could result in overheating, which could cause component damage.

4. Check the coolant level in the eDrive surge tank. See Fig.203, [Coolant Surge Tank \(one of two tanks\)](#).

If the coolant is low, fill the tank to the COLD MAX line with a 50/50 mixture of water and the type of antifreeze currently installed in your vehicle.

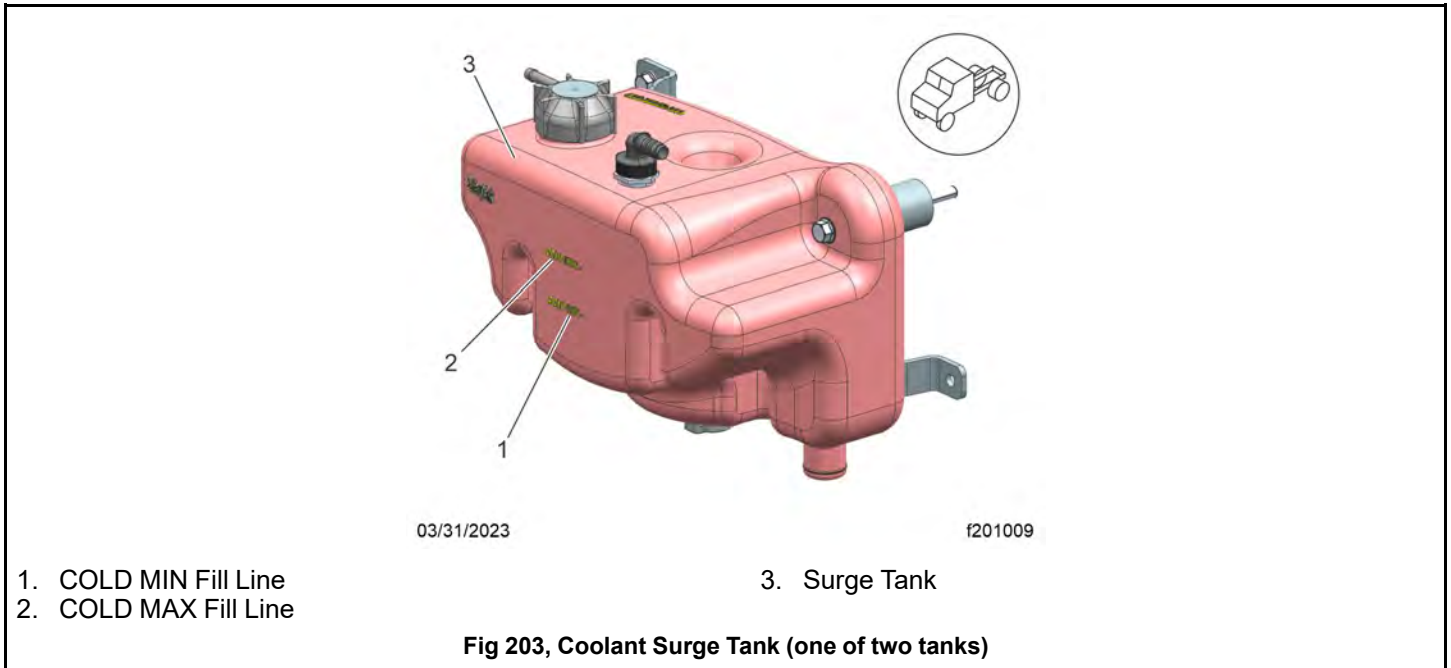

5. Check the coolant level in the battery surge tank. See Fig.203, [Coolant Surge Tank \(one of two tanks\)](#).

If the coolant is low, fill the battery system surge tank to the COLD MAX line with a 50/50 mixture of water and the type of antifreeze currently installed in your vehicle.

6. Inspect visible wiring for damage or looseness. Check for loose wiring, chafed insulation, and damaged or loose hold-down clamps.
7. Inspect visible frame rails for missing bolts, shiny areas, or rust streaks.
8. Close the hood.

19.02.06 Inspection of the Cab

1. With the key in the OFF position, check the air-pressure warning system.

NOTE: The low-air warning buzzer only works when the park brake is released. The low-air warning buzzer is silenced when the park brake is set.

- 1.a If not previously drained, drain the air reservoirs using moderate brake applications until pressure in both reservoirs is less than 70 psi (483 kPa).
- 1.b Turn the key to the ON position. The ICU will complete a self-check, and a low-air warning buzzer will sound. Ensure the low air pressure lamp (BRAKE AIR) remains illuminated and a low-air warning buzzer continues to sound after the ICU self-check is complete.
2. Check air governor cut-in and cut-out pressures.
 - 2.a Start the vehicle and ensure the BRAKE AIR lamp goes out and the buzzer silences when pressure reaches approximately 70 psi (483 kPa) in both air reservoirs.
The air governor should cut out at approximately 120 psi (827 kPa).
 - 2.b Apply the brake pedal several times. The air governor should cut in when pressure in the primary air reservoir (top air gauge) reaches approximately 100 psi (689 kPa).
3. Check air pressure build-up time.

- 3.a With the air system fully charged, make one full brake application and note the air pressure reading on the primary air gauge.
- 3.b Further reduce air pressure using moderate brake applications, then run the vehicle at governed rpm.
- 3.c Note the time that the pressure reaches the previously noted reading on the primary air gauge, then note the time that the air pressure reaches cut-out pressure.
- 3.d If it takes longer than 30 seconds to reach cut-out pressure after the primary air gauge passes the previously noted pressure (noted after one full brake application), eliminate any leaks or replace the air compressor before operating the vehicle.
4. Check air leakage in the system.
 - 4.a With the parking brake applied and the air system fully charged, release the service brakes and shut down the vehicle.
 - 4.b Wait one minute and note the air pressure drop in psi (kPa) per minute from the primary air reservoir.
If the pressure drop exceeds the limits shown, see Table.30, [Maximum Allowable Air Leakage](#), eliminate any leaks before operating the vehicle.
5. Check the air pressure reserve.

With the vehicle still off, make one full brake application and observe the pressure drop on the primary air gauge. If pressure drops more than 25 psi (172 kPa), eliminate any leaks before operating the vehicle.

Maximum Allowable Air Leakage		
Description	Pressure Drop: psi (kPa) Per Minute	
	Released	Applied
Truck or Tractor Only	2 (14)	3 (21)
Truck or Tractor w/Single Trailer	3 (21)	4 (28)
Truck or Tractor w/Two Trailers	5 (35)	6 (42)

Table 13, Maximum Allowable Air Leakage

**WARNING:**

When cleaning windshields and windows, always stand on the ground or on a secure ladder or platform. Use a long-handled window cleaner.

Do not use the cab steps, tires, fenders, fuel tanks, engine, or under-hood components to access the windshield or windows. Doing so could cause a fall and result in a severe injury.

**NOTICE:**

Do not use the turning vanes as handholds. Doing so could cause damage to the vehicle.

6. Inspect the mirrors, window glass, and windshield for cracks or other damage.
7. Ensure that the horn, windshield wipers, and windshield washers are operating properly. These devices must be in good working order for safe vehicle operation.
8. Turn the fan on and ensure the cab heater and window defroster are operating properly.
9. Check the operation of all interior lights.
 - 9.a Turn on the headlamps and leave them on.
 - 9.b Ensure ICU screens illuminate.
 - 9.c Ensure all equipped driver control switches illuminate and verify the interior cab lights controlled by these switches illuminate.
 - 9.d Ensure both turn signal indicators illuminate when the turn signal switch is activated.



03/31/2023

f548208

- | | |
|-----------------------------|---|
| 1. Clearance (Marker) Lamps | 5. Headlamp, Low Beam |
| 2. Identification Lamps | 6. Headlamp, High Beam |
| 3. Turn Signal | 7. Side Marker Lamp |
| 4. DRL/Accent Lamps | 8. Stop Lamps (Tail Lights), Turn Signals, Back-Up Lamp |

Fig 204, Exterior Lights

10. Check the operation of all exterior lamps. See Fig.204, [Exterior Lights](#).

Use the lamp check button on the key fob, see Fig.205, [Key Fob](#), or, if equipped, the LIGHT TEST switch by the driver's seat as, see Fig.206, [Pretrip Light Test Switch](#).

If neither are available, manually check the operation of all exterior lamps.

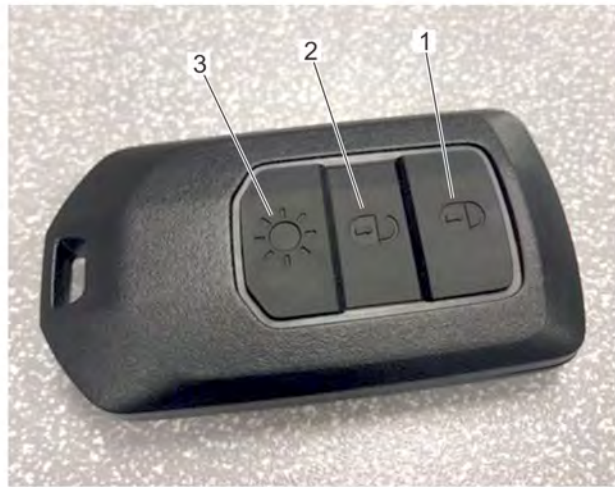

10/23/2019

f546880a

1. Door Lock
2. Door Unlock

3. Lamp Check

Fig 205, Key Fob

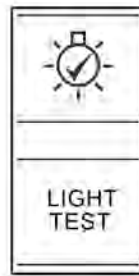

05/09/2022

f611436

Fig 206, Pretrip Light Test Switch

NOTE: Lamps added post-production, such as by a body builder, may or may not be incorporated in the light test groups. Manually check exterior lamps not included in the self-test.

11. To check the exterior lamps using the key fob lamp check button or the dash LIGHT TEST switch:
 - 11.a Make sure the parking brake is set.

NOTE: Vehicle factory settings will have groups of lamps activate sequentially up to 100 times or until manually stopped.

- 11.b Press either the LIGHT TEST switch or lamp check button to begin the pre-trip light inspection. If equipped, groups of lamps will cycle on and off in the following sequence:

- Group 1: Always ON: marker lamps, clearance lamps, tail lamps, licence plate lamp
- Group 2: Low beam headlamps
- Group 3: High beam headlamps and stop lamps
- Group 4: Backup lamps and daytime running lamps
- Group 5: Front and rear fog lamps
- Group 6: Turn signals and utility lamps

NOTE: LED accent lighting turns off when the high beam headlamps turn on.

- 11.c Walk around the truck and check that the lamps are working properly.
- 11.d Verify that all exterior lights and reflectors are clean and intact.
- 11.e The pretrip light inspection can be stopped by:
 - releasing the parking brake;
 - pressing either the lamp check button on the key fob or the LIGHT TEST switch on the dash.
- 12. To check exterior lamps manually:
 - 12.a Turn the keyswitch to the ON or ACC ON position.
 - 12.b Make certain the parking brake is set.
 - 12.c Activate the high-beam headlamps and hazard warning lamps.
 - 12.d Exit the cab and check that all exterior lamps and reflectors are clean and intact.
 - 12.e Check that the brake lamps, tail lamps, headlamps, turn signals, marker lamps, identification lamps, and clearance lamps are working properly.

**WARNING:**

Inspect and maintain seat belts. When any part of a seat belt system needs replacement, the entire seat belt must be replaced, both retractor and buckle side. Any time a vehicle is involved in an accident, and the seat belt system was in use, the entire vehicle seat belt system must be replaced before operating the vehicle. Do not attempt to modify the seat belt system; doing so could change the effectiveness of the system. Failure to replace worn or damaged seat belts, or making any modifications to the system, may result in personal injury or death.

- 13. Inspect the seat belts and tether belts.
 - 13.a Check the web for fraying, cuts, extreme dirt and dust, or for severe fading from exposure to sunlight, especially near the buckle latch plate and in the D-loop guide area.
 - 13.b Check operation of the buckle, latch, web retractor, and upper seat belt mount on the door pillar. Check all visible components for wear or damage.
 - 13.c Check the seat belt and tether belt connection points and tighten any that are loose.
- 14. Adjust the rearview and down view mirrors as necessary.
- 15. Test the service brakes.
 - 15.a With the key ON and air system fully charged, set the parking brake.
 - 15.b Put the vehicle in the lowest gear and gently attempt to move it forward. The vehicle should not move.

If the vehicle moves, the parking brakes are not operating correctly and must be repaired before the vehicle is operated.

16. Test the backup beep.

16.a Release the parking brake.

16.b Move the vehicle slightly backward to ensure that the backup beep is audible.

17. Press the 'Test' button on the combustible gas detection system control panel.

The system will illuminate the 'Trace Gas,' 'Significant,' and all other sensor LEDs, and sound the piezo buzzer. Watch to see that all lights illuminate or flash and listen to verify the buzzer alarm goes off.

If the self-diagnostic test fails, have the gas detection system repaired before putting the vehicle into service.

19.03 Weekly Post-Trip Inspections and Maintenance

19.03.01 Inspection of the Front Box



WARNING:

Washer fluids may be flammable and poisonous. Do not expose washer fluid to an open flame or any burning material, such as a cigarette. Always comply with the washer fluid manufacturer's recommended safety precautions.

1. Open the hood.
2. Check the windshield washer reservoir fluid level. The reservoir is located near the right-hand frame rail. See Fig. 207, [Windshield Washer Reservoir](#).



1. Washer Fluid Filler Cap

2. Battery Cable Access (BCA) Box

Fig 207, Windshield Washer Reservoir

3. Inspect water evacuation components.
 - 3.a Inspect the rain tray installed at the base of the windshield. Ensure that the seal on the forward edge of the rain tray is in good condition.
 - 3.b Inspect the drain hoses installed on the rain tray. Both hoses should be securely attached to the rain tray and direct water down the aft side of the front fenders.
4. Inspect the air vent hoses and verify the red caps are in place.
5. Inspect the steering components.
 - 5.a Inspect tie rods, steering arms, and the drag link for signs of looseness (i.e., shiny spots or rust tracks).
 - 5.b Check the steering gear mounting bolts for signs of looseness.
 - 5.c Inspect the steering intermediate shaft and end yokes for excessive looseness or other damage.
6. Close the hood.

19.04 Monthly Post-Trip Inspections and Maintenance

19.04.01 Inspection of the Brake Component

Walk around the vehicle and inspect brake system components for visible damage.

NOTE: Some vehicles may be equipped with a brake check valve on the dash, which allows the driver to set the service brakes and exit the vehicle to check the brake system for leaks. The parking brakes must be applied before the brake check valve will function.

1. Inspect all visible brake system components for missing fasteners or signs of looseness, such as rust tracks.

**NOTICE:**

If the external breather tube or breather cap is missing or incorrectly installed, road dirt and debris can adversely affect the operation of the brake chamber. Once inside of the chamber, dirt and debris can cause the internal parts of the chamber to deteriorate faster.

2. Inspect the exterior surfaces of brake chambers for damage. Make sure that breather holes are open and free of debris.

NOTE: Do not route air brake lines on top of anything likely to be stepped on.

3. Inspect air brake lines for dents, swelling, kinks, twisting, abrasion, and damage, especially near moving parts.
4. Inspect flex air lines for deterioration or signs of abrasion.
5. Inspect for cracked, worn, or oil-contaminated brake linings and brake drums (or rotors).
6. Check the thickness of the brake linings. Replace brake linings on all brake assemblies on the axle if any brake linings are worn to less than approximately 1/4 inch (6.4 mm) at the thinnest point.

19.04.02 Inspection of the eAxle

1. Check and inspect the rear pads.
2. Check and inspect the mounting brackets for loose bolts.

19.04.03 Inspection of the Mid-Frame Area

**WARNING:**

When draining the air reservoir, do not look into the air jets or direct them toward anyone. Dirt or sludge particles may be in the airstream and could cause injury.

**NOTICE:**

If the water drained from the air reservoirs is cloudy or oily, it may indicate a problem with the compressor. If oil is allowed to contaminate the air dryer, it will not remove the water from the air brake system, which could adversely affect braking.

1. On vehicles without automatic drain valves, drain the brake system air reservoirs.

IMPORTANT: Aerodynamic components decrease drag force as a vehicle moves, thereby improving fuel efficiency. If replacement of an aerodynamic component is necessary, replacement components must meet or exceed the drag reduction performance of the originally installed component in order to maintain compliance with greenhouse gas and fuel efficiency regulations.

2. Inspect the following aerodynamic components, if equipped, for structural damage, cracks, or wear.
 - Roof fairing/deflector
 - Side skirts
 - Cab extenders

19.04.04 Inspection and Adjustments of the Front Box

IMPORTANT: If replacement of the hood or bumper is necessary, the replacement component must meet or exceed the drag reduction performance of the originally installed item in order to maintain compliance with greenhouse gas and fuel efficiency regulations.

NOTE: Anytime a hood is adjusted, removed, or reinstalled, the headlamp aim should be checked.

1. Inspect the bumper and hood for structural damage, cracks, or wear.
2. Open the hood.

Inspect the radiators and heater hoses, including the clamps and support brackets.

NOTE: When traveling through areas of high insect concentration, it may be necessary to clean the exterior of the radiators as often as every 200 miles (320 km).

- 2.a Inspect the battery radiator for damage and accumulated debris. Straighten bent or damaged fins to permit air-flow across all areas of the cores.
- 2.b Inspect the vehicle radiator for damage and accumulated debris. Straighten bent or damaged fins to permit air-flow across all areas of the cores.
- 2.c Make sure the inlet and outlet hoses on the radiators are pliable and are not cracking or ballooning.
- 2.d Make sure the heater hoses are pliable and are not cracking or ballooning.
- 2.e Tighten hose clamps as necessary.

IMPORTANT: Do not overtighten hose clamps, as hose life can be adversely affected.

- 2.f Ensure hose support brackets are securely fastened. Make sure hoses are not located near sources of wear, abrasion, or high heat.



WARNING:

Battery posts, terminals, and related accessories contain lead and lead compounds, chemicals known to the State of California to cause cancer and reproductive harm. To prevent possible personal injury, always wash your hands after handling battery parts and related accessories.

IMPORTANT: When replacing hoses, install service-type knitted or braided yarn-reinforced neoprene hose. Extended-service-life silicone hoses may also be used. See the Alliance Parts Catalog at www.alliancebrandparts.com or contact your Freightliner dealer.

3. Inspect the low-voltage batteries.
 - 3.a Remove the battery box cover and inspect all visible battery cables for loose wiring or damage.
 - 3.b Check that the battery hold-down is secure.
 - 3.c Install the battery box cover
 - 3.d Close the hood.
4. Check the steering wheel for excessive play.
 - 4.a Turn the key to the ON position. With the front tires straight ahead, turn the steering wheel until motion is observed at the front wheels.
 - 4.b Align a reference mark on the steering wheel to a rule, then slowly turn the steering wheel in the opposite direction until motion is again detected at the wheels.
 - 4.c Measure the lash (free play) at the rim of the steering wheel. Excessive lash exists if steering wheel movement exceeds 2-1/4 inches (57 mm) with an 18 inch (450 mm) steering wheel.
 - 4.d If there is excessive lash, check the steering system for wear or incorrect adjustment before operating the vehicle.

20.01 Shutting Down the High-Voltage System	260
20.02 Emergency Responder Cable Cut Point	260
20.03 Crash Detection	261
20.04 Combustible Gas Detection System	261
20.04.01 General Description	261
20.04.02 How the System Works	264
20.04.03 Sensor False Positives	269
20.04.04 Resetting the Control Module	269
20.04.05 Test the System Daily	269
20.05 In Case of a High-Voltage Battery Thermal Event.....	270
20.06 Activating the Hazard Warning Lights.....	271
20.07 Optional Emergency Equipment	272
20.08 In Case of Fire in the Cab.....	272
20.09 Jump Starting.....	273
20.10 In Case of an Under-Inflated or Flat Tire	275
20.11 Lifting and Lowering the Vehicle.....	276
20.11.01 Raising a Vehicle with Air Suspension.....	276
20.11.02 Lowering a Vehicle with Air Suspension	278
20.12 Towing the Vehicle.....	278
20.12.01 Front Towing Hookup	278
20.13 Dealing With a Submerged Vehicle	285

20. In An Emergency

20.01 Shutting Down the High-Voltage System

Shut Down The High-Voltage System

In case of fire, submersion, accident, or other emergency, shut down the high-voltage system.

To shut down the high-voltage system, press the red Emergency High-Voltage Disconnect, or eStop, button on the dash, see Fig. 208, [Emergency High-Voltage Disconnect Button](#).



Pressing the red button immediately disables the high-voltage system by stopping the flow of power to and from the high-voltage batteries.

Affixing a lock through the yellow switch guard stops the red button from popping out.

To release the button and resume the flow of power, remove any attached lock and spin the button to either the left or right.

20.02 Emergency Responder Cable Cut Point

If first responders are unable to access the eStop button on the dash, the high-voltage system can be disabled by cutting through one of the two cable cut points.

A cable cut point is located below and toward the back of each cab door; a right-hand cable cut point, see Fig. 209, [Emergency Responder Cable Cut Point](#). Each cable cut point is marked with a yellow first responder cable cut tag decorated with cable cutters and a fire helmet.

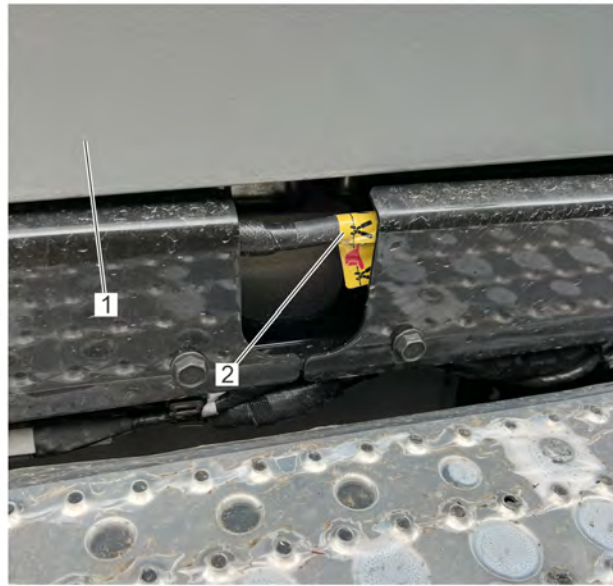

03/31/2023

f548205

1. Bottom of Right-Hand Cab Door

2. First Responder Cable Cut Point

Fig 209, Emergency Responder Cable Cut Point

20.03 Crash Detection

The crash detection feature monitors the vehicle for horizontal accelerations and rollover angles that would happen during a crash and that have a potential to injure the driver or cause damage to the high-voltage components.

When these movements are detected, the crash detection feature shuts down the high-voltage system and, if equipped, deploys the SRS air bag.

20.04 Combustible Gas Detection System

20.04.01 General Description

IMPORTANT: The gas detection system must be powered at all times. The gas detection system must be wired directly into the 12V batteries so that it can only be powered off by disconnecting the 12V batteries. When servicing the vehicle, disconnect the 12V batteries only when necessary and do not leave them disconnected for extended periods of time.

A USA Pro Shoreline multizone combustible gas detection system is standard equipment on an eM2. The system is designed to give early warning of a high-voltage battery thermal event. It does this through detecting hydrocarbon gas levels — methane, propane, butane, hydrogen, methanol, ethanol, diesel fuel, gasoline — and warning about these gas levels before they reach their lower explosive limit (LEL).

The LEL is the smallest amount of the gas that supports a flame when mixed with oxygen and ignited. Zero percent (0%) LEL indicates a gas-free atmosphere. One hundred percent (100%) LEL indicates that the air concentration for that gas has reached its lower explosive limit.

The system consists of two external sensors and a control panel.

The sensors are located under the deck plates at the midpoint of the high-voltage batteries, see Fig. 210, [Gas Detection System Sensors](#). This places them where rising gas vapors from the high-voltage batteries pass by or accumulate.

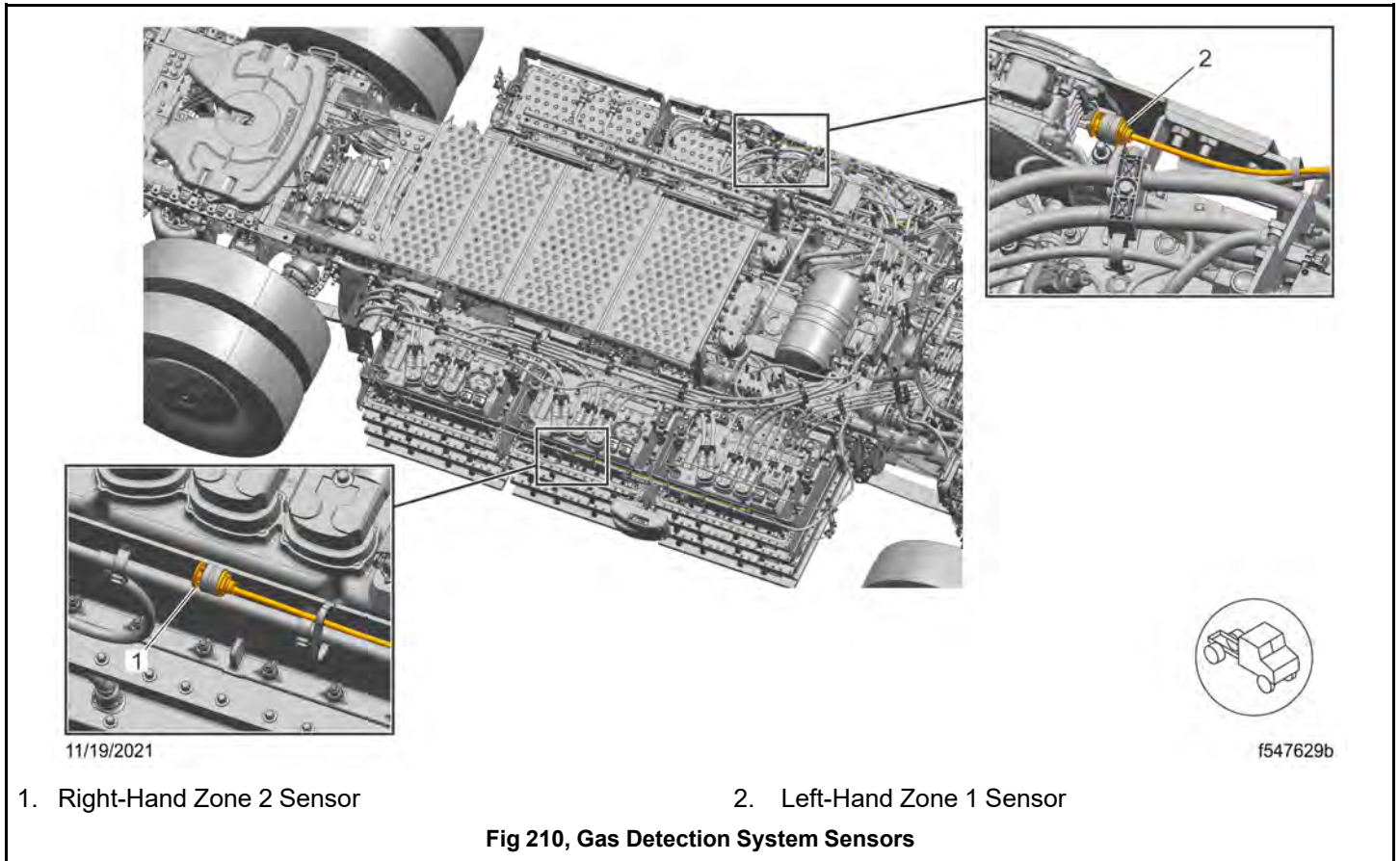

Two labels on the control panel highlight important information about the combustible gas detection system. The combustible gas status label, see Fig.211, [Combustible Gas Status Label](#) serves as a reminder to what the warning light colors represent. The warning label, see Fig.212, [Control Panel Warning Label](#) outlines what to do if the buzzer sounds and the lower red indicator illuminates.

The control panel is mounted in the front overhead panel of the cab, see Fig. 213, [USA Pro Shoreline Multizone Detection System Control Module](#).

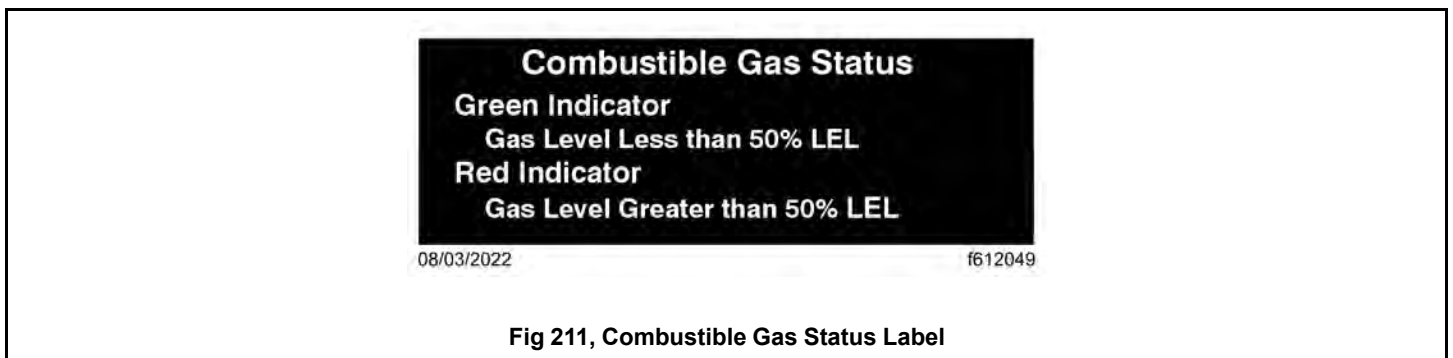



11/18/2021

f080387

Fig 212, Control Panel Warning Label

**WARNING:**

Immediately bring the vehicle to a safe stop when the buzzer alarm sounds and the lower red 'Significant' LED illuminates. Apply the park brake, turn off the ignition, and get clear of the vehicle.

If possible, hit the eStop button the dash prior to exiting the cab.

Move a safe distance from the vehicle, fifty to one hundred feet if possible, and upwind of any smoke. Call emergency services.

If possible, set out reflectors or flares to keep other people and vehicles at a safe distance and to guide them around the vehicle.

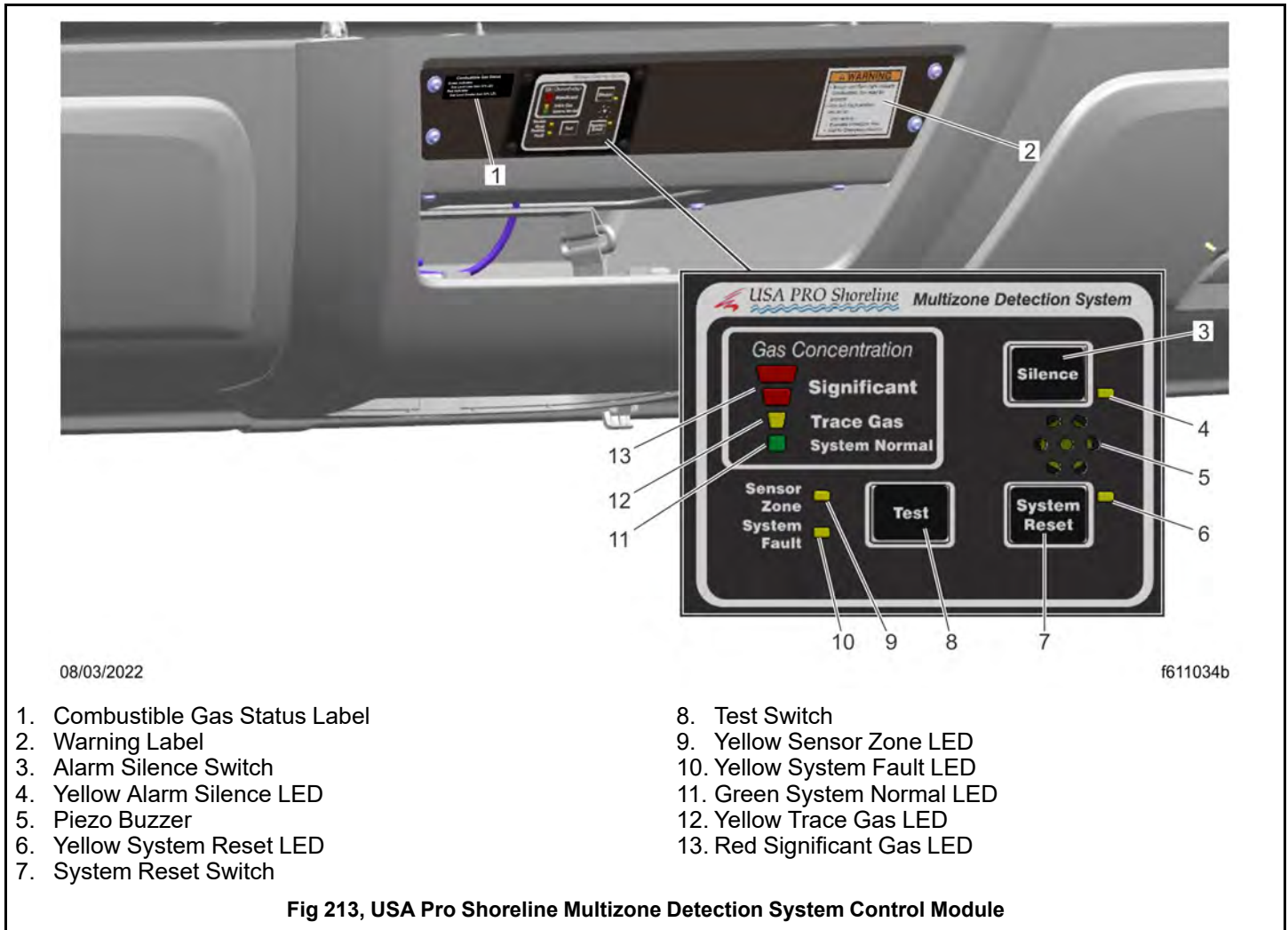

- 1. Combustible Gas Status Label
- 2. Warning Label
- 3. Alarm Silence Switch
- 4. Yellow Alarm Silence LED
- 5. Piezo Buzzer
- 6. Yellow System Reset LED
- 7. System Reset Switch

- 8. Test Switch
- 9. Yellow Sensor Zone LED
- 10. Yellow System Fault LED
- 11. Green System Normal LED
- 12. Yellow Trace Gas LED
- 13. Red Significant Gas LED

Fig 213, USA Pro Shoreline Multizone Detection System Control Module

20.04.02 How the System Works

Systems Normal

A steady green 'System Normal' LED indicates:

- the system is powered on,
- all components are operating normally,
- gas levels, if detected, are equal to or below 50 percent of the LEL.

It is good practice to verify the system LED is green before entering the vehicle. Though the panel is designed to be read when sitting inside the cab, the green light can clearly be seen through the back windows of the cab. It is also visible when standing next to the B-pillar and looking up through the side windows.

Trace Gas Levels Detected

A steady yellow 'Trace Gas' LED indicates a gas concentration greater than 20 percent of the LEL for that gas has been detected. A sensor has to detect an excess of 20 percent LEL for two continuous seconds before this lamp will illuminate.

The yellow 'Sensor Zone' LED will flash to indicate what sensor is reporting the LEL levels. A single flash indicates zone 1, the left-hand sensor, and a double flash indicate zone 2, the right-hand sensor.

The detection of trace gas amounts will not cause the buzzer alarm to sound.

If ambient gas levels return to normal, the yellow 'Trace Gas' LED will go out and the green 'Systems Normal' LED will illuminate.

What To Do When Trace Gas Levels Are Detected

Look in the mirrors for evidence of white smoke escaping from behind the cab or from the batteries.

If there is smoke:

- Pull over into a safe location as soon as possible.
- Turn off the ignition, set the park brake, press the eStop button, and exit the vehicle.
- Move a safe distance from the vehicle, fifty to one hundred feet if possible. Avoid inhaling the smoke. When in a safe location, call emergency services.



NOTICE:

If possible, set out reflectors or flares to keep other people and vehicles at a safe distance and to guide them around the vehicle.

If the alarm is false, do not consider the area clear until emergency responders have declared the area safe, all alarm indicators are OFF, and the alarm panel light illuminates green.

If smoke or flames are coming from a high voltage battery, trained emergency responders should use large amounts of water to cool the battery. Battery fires can take up to 24 hours to extinguish. Emergency responders should consider allowing the battery to burn in place.

Do not tow a vehicle until all fires have been extinguished and the high-voltage batteries are no longer giving off heat. After a fire, do not store a towed vehicle indoors.

If there is no smoke:

- Pull over into a safe location.
- Turn off the ignition, set the park brake, and exit the vehicle.
- If applicable, call a supervisor for assistance.
- Observe the vehicle for fifteen minutes.
- If you observe smoke, move a safe distance from the vehicle, fifty to one hundred feet if possible. Avoid inhaling the smoke. When in a safe location, call emergency services.
- If no smoke is observed after fifteen minutes, enter the truck and check for high-voltage or battery faults and warnings.

If faults are active HV related fault codes that prevent High Voltage from energizing, contact a supervisor. If there are HV related fault codes, but HV is energized and truck is able to drive, follow the information displayed on the instrumentation cluster or B-panel (most likely drive to nearest service center).

If no faults are present, drive the vehicle to the nearest service center. The vehicle should not be in operation until the problem is diagnosed and resolved.

Significant Gas Levels Detected



WARNING:

Immediately bring the vehicle to a safe stop when the buzzer alarm sounds and the lower red 'Significant' LED illuminates. Apply the park brake, turn off the ignition, press the eStop button, and get clear of the vehicle.

Waiting to see if the upper red 'Significant' LED illuminates after one minute could result in severe personal injury or death.

**WARNING:**

If outside the vehicle when the alarm buzzer sounds, do not attempt to open or enter the cab to retrieve items, turn off the ignition, or hit the eStop button; doing so could result in severe personal injury or death.

NOTE: The green 'Systems Normal' light is extinguished when the red 'Significant' LED illuminates. This does not indicate that the system has lost power or is not operating normally.

If gas concentrations increase to the 50 percent LEL for that gas, and maintain or exceed that level for six continuous seconds, the lower red 'Significant' LED illuminates and the buzzer alarm activates and emits a continuous alarm.

If ambient gas levels return to normal, the lower red 'Significant' LED goes out and the green 'Systems Normal' LED illuminates.

If gas concentrations greater than 50 percent of the LEL for that gas persist or increase for more than one minute, the upper red 'Significant' LED illuminates and the buzzer alarm starts beeping.

Once the upper 'Significant' LED comes on and the buzzer starts beeping, they continue to do so until the 'System Reset' button is pressed.

If the 'System Reset' button is pressed before ambient gas levels have dropped, the gas detection system will restart the alarm sequence.

What To Do When Significant Gas Levels Are Detected

Look in the mirrors for evidence of white smoke escaping from behind the cab or from the batteries.

If there is smoke:

- Pull over into a safe location as soon as possible.
- Turn off the ignition, set the park brake, press the eStop button, and exit the vehicle.
- Move a safe distance from the vehicle, fifty to one hundred feet if possible. Avoid inhaling the smoke. When in a safe location, call emergency services.

**NOTICE:**

If possible, set out reflectors or flares to keep other people and vehicles at a safe distance and to guide them around the vehicle.

If the alarm is false, do not consider the area clear until emergency responders have declared the area safe, all alarm indicators are OFF, and the alarm panel light illuminates green.

If smoke or flames are coming from a high voltage battery, trained emergency responders should use large amounts of water to cool the battery. Battery fires can take up to 24 hours to extinguish. Emergency responders should consider allowing the battery to burn in place.

Do not tow a vehicle until all fires have been extinguished and the high-voltage batteries are no longer giving off heat. After a fire, do not store a towed vehicle indoors.

If there is no smoke:

- Pull over into a safe location.
- Turn off the ignition, set the park brake, and exit the vehicle.
- If applicable, call a supervisor for assistance.
- Observe the vehicle for fifteen minutes.

- If there is smoke, move a safe distance from the vehicle, fifty to one hundred feet if possible. Avoid inhaling the smoke. When in a safe location, call emergency services.
- If there is no smoke, enter the truck and check for high-voltage or battery faults and warnings.

If there are active HV related fault codes that prevent High Voltage from energizing, contact a supervisor. If there are HV related fault codes, but HV is energized and truck is able to drive, follow the information displayed on the instrumentation cluster or B-panel (most likely drive to nearest service center).

If no faults are present, and if applicable, call a supervisor to discuss next steps. The vehicle cannot be driven until the problem is diagnosed and resolved.

System Faults

If a sensor has been disconnected or malfunctioned, the green 'System Normal' LED goes out and the yellow 'System Fault' LED illuminates. The yellow 'Sensor Zone' LED flashes to indicate the zone of the malfunctioning sensor. A single flash indicates zone 1, the left-hand sensor, and a double flash indicates zone 2, the right-hand sensor. If the system fault indicates a sensor zone not on the vehicle, the gas detection system needs to be reprogrammed.

If the wiring from the control panel to sensor has been damaged, only the 'System Fault' LED flashes.

If a sensor has been disconnected, malfunctioned, or the control panel wiring has been damaged, have the vehicle serviced. Do not operate the vehicle without a functioning gas detection system.

To reprogram the gas detection display:

1. Press the 'System Reset' and 'Silence' buttons at the same time for at least ten seconds.
2. Release the buttons when the alarm sounds and the 'Systems Normal' LED flashes. This indicates you have entered programming mode.
3. Press the 'Silence' button to cycle through the different sensor zones. The sensor zone LED flashes to indicate the current sensor.
4. If the amber 'Trace Gas' LED illuminates on the current sensor zone, this means the current sensor zone is being monitored. Press the 'Test' button to disable/enable monitoring of the current sensor zone.
5. Wait one minute. If no action is taken for one minute, the alarm sounds twice to notify programming is complete and normal operation is engaged.

For the functions of all lights and buttons on the overhead console, see Table 31, [USA Pro Shoreline AMGaDS III Plus Control Module Functions](#).

USA Pro Shoreline Multizone Detection System Control Module

Item	Display	Function	Action Required
'System Normal' LED	Green (illuminated)	System is on and all components are operating properly.	None required.
	Unlit	Detection system is not functioning.	Ensure the batteries are connected and replace any blown fuses. If the gas detection system is still not functioning, immediately replace the system.
'Trace Gas' Concentration LED	Yellow (illuminated)	Minor gas concentration detected.	Use caution and watch the control panel.
'Significant' Gas Concentration LEDs	Red Lower Bar (illuminated)	Dangerous gas concentration at or above 50% of the LEL have been detected. The buzzer alarm sounds.	Quickly bring the vehicle to a safe stop. Apply the park brake, turn off the ignition, exit the cab, and call emergency responders.

Table 31, USA Pro Shoreline AMGaDS III Plus Control Module Functions

Item	Display	Function	Action Required
		The green 'System Normal' LED goes out.	
	Red Upper Bar (illuminated)	Dangerous gas concentration at or above 50% of the LEL present for over 1 minute.	Immediately bring the vehicle to a safe stop. Apply the park brake, turn off the ignition, exit the cab, and call emergency responders.
'Sensor Zone' LED	Off	Sensors are functioning properly.	None required.
	On (flashing)	Specifies sensor zone. Single flash designates zone 1. Double flash designates zone 2.	If paired with gas concentration LED, this indicates which sensor is registering the gas concentration. If paired with 'System Fault' LED, this indicates which sensor is registering as non-operational.
'System Fault' LED	Off	Sensors are functioning properly.	None required.
	On	A system component has malfunctioned.	If only the 'System Fault' LED is flashing, verify the wiring from the control panel to the sensor. If the 'Sensor Zone' LED is flashing, verify the designated sensor is connected and operational. Replace damaged sensors immediately.
'System Reset' Switch	—	Resets the system after an alarm.	Reset the system only after the gas has cleared and emergency responders have declared the vehicle safe.
'System Reset' Switch LED	Yellow (illuminated)	Indicates the system has been successfully reset.	None required.
	Off	Normal condition.	None required.
'Test'	—	Pressing the switch illuminates all the control panel LEDs and transfers all I/O contacts.	Test the system daily.
'Silence' Switch	—	Silences the alarm buzzer.	Press to silence the alarm buzzer.
'Silence' Switch LED	Yellow (illuminated)	Indicates the buzzer is active but silenced.	Quickly bring the vehicle to a safe stop. Apply the park brake, turn off the ignition, exit the cab, and call emergency responders.
	Off	Normal condition.	None required.

Table 14, USA Pro Shoreline AMGaDS III Plus Control Module Functions

20.04.03 Sensor False Positives

**NOTICE:**

Daimler Truck North America (DTNA) does not recommend cleaning or disinfecting a vehicle with products that contain silicone. Silicone-based chemicals and cleaners may disable the sensors.

Harsh chemicals and extremely high temperatures may damage the sensors.

Puncture of or damage to the seal located inside the sensor housing will significantly shorten the sensor life.

Periodic testing is required to verify sensor operation.

The sensors are sensitive to all hydrocarbon vapors.

An alarm may be triggered by cleaning products, paint, polish, lacquer, gasoline, silicone, silicone spray, or other chemicals. The sensors may also detect hydrogen fumes from an overcharged 12V battery.

If the alarm buzzer goes off but it is determined that the high-voltage batteries are not involved in a high-thermal event, check for recent use of chemicals or a battery charger.

20.04.04 Resetting the Control Module

Do not attempt to reset the system until the gas has cleared, and, if called, emergency personnel have declared the vehicle safe.

- Silence: If an alarm has been activated by cleaning chemicals or a fault, pressing the 'Silence' switch will silence the alarm buzzer.
- System Reset: press the 'System Reset' switch to transfer I/O contacts and turn off the yellow alarm 'Silence' LED.

20.04.05 Test the System Daily

**NOTICE:**

Daimler Truck North America (DTNA) strongly recommends that all operators follow California Code of Regulations (CCR) inspection requirements, regardless of where the vehicle is operated. Per Title 13 CCR § 935 (2), gas detection systems should be tested three times per calendar year at equal intervals. The testing procedure should simulate the same operating environment in which the vehicle is used.

Test results validating the performance of the gas detection system within the parameters established by the component manufacturer and NFPA 52 should be maintained as a permanent part of the vehicle service records. Use of alcohol, propane, and other harsh liquids or gases are not acceptable methods for testing.

Press the 'Test' button on the control panel daily.

The system will proceed with a self-diagnostic test that will include illumination of the 'Trace Gas,' 'Significant,' and all other sensor LEDs. It will also sound the piezo buzzer. Listen to verify the buzzer alarm goes off and watch to see that all lights illuminate or flash.

Test the sensors three times per calendar year, after any system component has been replaced, and if the vehicle was involved in an accident or fire.

The gas detection system sensors must be tested regularly by a trained technician, using certified test equipment that satisfies CCR § 935 (2) or NFPA 52 regulations.

DTNA recommends the highest level of safety validation if there are multiple validation requirements in the state or locality where the vehicle is operated or domiciled.

20.05 In Case of a High-Voltage Battery Thermal Event

The vehicle is equipped with a thermal event detection system to spot thermal events inside the high-voltage batteries.

Gas detection sensors that identify external off-gassing associated with high-voltage battery thermal events back-up this system. The gas detection sensors are always active, even when the vehicle is off. For more information, see the **Combustible Gas Detection System** section in this chapter.

The driver should be familiar with the vehicle warning systems in order to bring the vehicle to a safe stop or avoid starting the vehicle if a high-voltage thermal event is detected.



DANGER:

When fire is involved, consider the entire vehicle energized and **DO NOT TOUCH** any part of the vehicle. Doing so could result in severe personal injury or death.

Emergency responders should protect themselves with full personal protective equipment (PPE).



WARNING:

A damaged high voltage battery can create rapid heating of the battery cells.

If smoke is coming from a high voltage battery assume that it is heating. Leave the area. Avoid breathing in the smoke. Breathing in the smoke could result in severe personal injury.



NOTICE:

If smoke or flames are coming from a high voltage battery, trained emergency responders should use large amounts of water to cool the battery.

Battery fires can take up to 24 hours to extinguish. Emergency responders should consider allowing the battery to burn in place.

Do not tow a vehicle until all fires have been extinguished and the high-voltage batteries are no longer giving off heat.

After a fire, do not store a towed vehicle indoors.

If a thermal event is detected inside a high-voltage battery when the vehicle is on, the following things will happen:

- The red high-voltage battery thermal event telltale, see Fig.214, [High-Voltage Battery Thermal Event Telltale](#), appears in the dynamic telltale section of the driver display.
- A red warning message, see Fig.215, [Thermal Event Warning Message](#), appears in the center of the driver display screen.

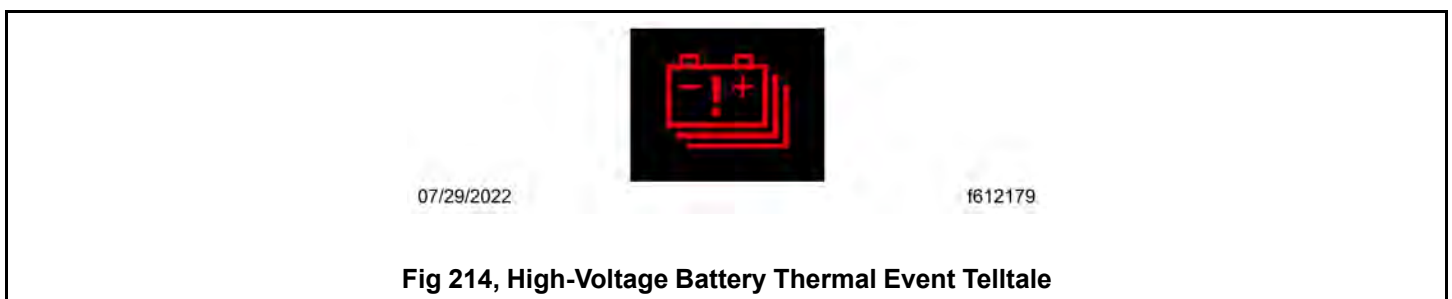

Fig 214, High-Voltage Battery Thermal Event Telltale



Fig 215, Thermal Event Warning Message

The warning message must be acknowledged before it will close.

The vehicle will continue to operate in the case of a thermal event occurring in only one battery pack. However, the driver is strongly advised to bring the vehicle to a safe stop, apply the park brake, turn the keyswitch to off, hit the eStop button, and exit the cab within five minutes of seeing the thermal popup warning. A failure resulting in a thermal event in one battery pack can spread to all packs.

If smoke or flames from the area of the batteries are visible, do **not** approach the batteries for any reason. Do **not** attempt to use a fire extinguisher or other methods to put the fire out. Move a safe distance from the vehicle, fifty to one hundred feet if possible, and upwind of any smoke. Then call emergency services.

A battery fire will produce a thick, dark smoke that can impair visibility. If possible, set out reflectors or flares to keep other people and vehicles at a safe distance and to guide them around the vehicle.

20.06 Activating the Hazard Warning Lights

The hazard warning light switch is located on the dash, see Fig.216, [Emergency Switches on the eM2 Dash](#).



1. Hazard Warning Lights Switch

2. Emergency High-Voltage Disconnect Button

Fig 216, Emergency Switches on the eM2 Dash

The hazard warning lights can be activated regardless of the key position.

To activate the hazard lights, push the center of the triangular switch. All the turn signal lights on the vehicle and trailer, as well as the turn signal indicators in the ICU flash simultaneously when the hazard lights are activated.

Push the switch again to turn the hazard lights off.

20.07 Optional Emergency Equipment

Optional emergency equipment that can be ordered with the vehicle includes:

- a fire extinguisher
- a first aid kit
- triangular reflectors
- road flares

If ordered, optional emergency equipment will be located in the cab, usually near the driver's seat. It is recommended that the driver store emergency equipment within easy reach.



WARNING:

Use extreme care when placing road flares in emergency situations that involve exposure to flammable substances. A fire could occur causing serious personal injury.

If there is an emergency while driving:

- Quickly and safely pull off the road.
- Turn on the hazard warning lights.
- Place reflectors or road flares along the side of the road to alert other drivers that an emergency situation exists.

20.08 In Case of Fire in the Cab



DANGER:

When fire is involved, consider the entire vehicle energized and **DO NOT TOUCH** any part of the vehicle. Doing so could result in severe personal injury or death.

Emergency responders should protect themselves with full personal protective equipment (PPE).



WARNING:

Do not allow flames, sparks, or any other heat sources (such as cigarettes or light bulbs) to contact materials in the cab. Any materials in the cab in contact with these heat sources could cause serious personal injury or vehicle damage.

**NOTICE:**

After a fire, do not store a recovered electric vehicle indoors.

When a fire in the cab is detected, quickly bring the vehicle to a safe stop, apply the park brake, and turn off the vehicle. If possible, hit the eStop button on the dash prior to exiting the cab.

According to data from the National Highway Traffic Safety Administration, the incidence of fire in heavy- and medium-duty trucks is rare. In addition, Federal Motor Vehicle Safety Standard #302 limits the flammability of specified materials used inside the cab. However, most materials can burn.

20.09 Jump Starting

**WARNING:**

Batteries release explosive gas. Do not smoke when working around batteries. Put out all flames and remove all sources of sparks or intense heat in the vicinity of the battery.

Do not allow the vehicles to touch each other. Do not lean over the batteries when making connections. Keep all other persons away from the batteries.

Failure to follow these precautions could lead to severe personal injury as a result of an explosion or acid burns.

**NOTICE:**

The eM2 contains two low-voltage systems: 24V and 12V. These directions detail the steps to charge or 'jump start' the 12V batteries. On an eM2, the 12V batteries must be operational for the high-voltage batteries to activate.

To jump start another vehicle from an eM2, both the 12V and the high-voltage (HV) batteries on the eM2 **must** be active. An active high-voltage system is necessary to keep the low-voltage (12V) charge at a sufficient level to provide the 'jump.'

To jump start another vehicle from an eM2, follow the directions below, switching out the other vehicle for 'the eM2' and 'the eM2' for the 'the power source.'

Only use jumper cables approved for use with heavy duty vehicles. The use of inadequate or damaged jumper cables may damage both vehicles.

Do not connect an eM2 to a vehicle with a different operating voltage. Electronic devices on both vehicles can be damaged if vehicles with different operating voltages are connected.

NOTE: eM2 vehicles are equipped with under-hood jump start posts; **always** connect to these posts instead of the batteries.

When using jumper cables, follow the instructions below.

1. Apply the parking brakes and turn off the lights and all other electrical devices.
2. Open the hood.

**NOTICE:**

Always connect the battery, jumper cables, and charger correctly (positive-to-positive, negative-to-negative). Connecting a charging device backwards (positive-to-negative or negative-to-positive) will damage the vehicle.

3. Connect one end of a 12V positive (+) jumper cable to the 12V positive (+) post on the electric vehicle distribution module (EVDM), see Fig.217, [Positive and Negative Posts on the EVDM](#).



11/18/2021

f547684

1. Positive Post

2. Negative Post

Fig 217, Positive and Negative Posts on the EVDM

4. Connect the other end of the 12V positive (+) jumper cable to the 12V positive (+) connection on the power source providing the jump start.

The power source may be a battery, external battery charger, or the jump start post of a vehicle.

**WARNING:**

Do the next step exactly as instructed and do not allow the clamps of one cable to touch the clamps of the other cable. Otherwise, a spark could occur near a battery, possibly resulting in severe personal injury from explosion or acid burns.

5. Connect one end of the negative (-) jumper cable to the negative (-) connection on the power source providing the jump start.
The power source may be a battery, external battery charger, or the jump start post of a vehicle.
6. Connect (ground) the other end of the (-) jumper cable to the negative (-) jump start post on the eM2, see Fig. 217, [Positive and Negative Posts on the EVDM](#).
7. Start the power source providing the jump start. This could mean starting the engine of the vehicle providing the jump start or turning on an 12V external battery charger.
Let the power source run a few minutes to charge the batteries of the vehicle being jump started.
8. On the vehicle being jump started, turn the key to the “start” position.
9. Once the high-voltage system is enabled, continue to allow the eM2 to charge until all ICU low-voltage warnings turn off.

**WARNING:**

Do the next step exactly as instructed and do not allow the clamps of one cable to touch the clamps of the other cable. Otherwise, a spark could occur near a battery, possibly resulting in severe personal injury from explosion or acid burns.

10. Disconnect the negative (-) (grounded) jumper cable from the negative (-) post on the vehicle that needed the jump start. See Fig. 217, [Positive and Negative Posts on the EVDM](#).
11. Disconnect the other end of the negative (-) jumper cable from the power source that provided the jump start.
12. Disconnect the positive (+) jumper cable from the positive (+) power source that provided the jump start.
13. Disconnect the other end of the positive (+) jumper cable from the 12V positive (+) post on the EVDM of the eM2. See Fig. 217, [Positive and Negative Posts on the EVDM](#).
14. Close the hood.

20.10 In Case of an Under-Inflated or Flat Tire

The eM2 is equipped with a tire pressure monitoring system (TPMS) which monitors tire pressure and temperature. For full information on the TPMS, see [5.01.01 General Information : Instruments](#). The TPMS can be accessed on the infotainment panel in the vehicle.

The TPMS shows the tire pressure in pounds per square inch (psi) or bar units and color codes this information to communicate its severity level. See Fig. 218, [Tire Pressure Monitoring System \(TPMS\), Tire Pressure - ICC5](#).

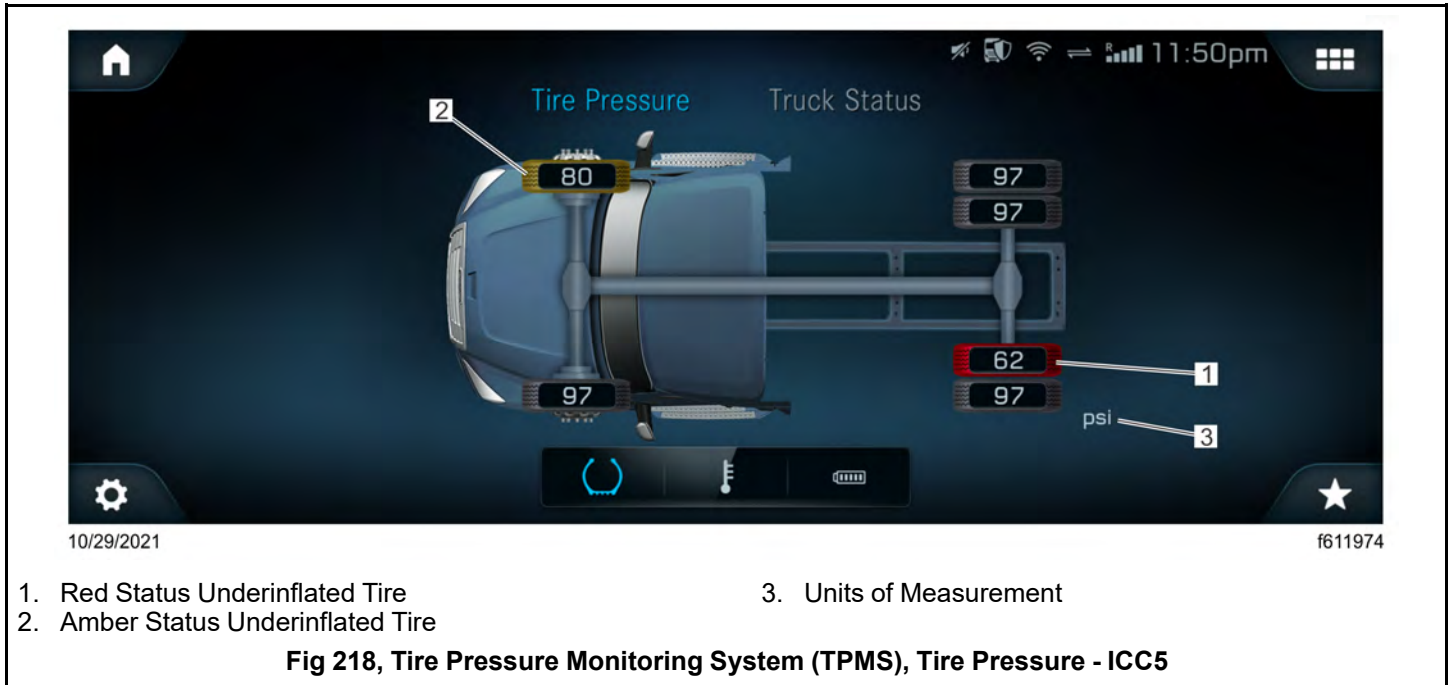

Red status indicates that the tire pressure poses a threat to the control of the vehicle.

Amber status indicates a condition that may result in damage to the vehicle. Driving with under-inflated tires may permanently damage the tires and increases the likelihood of tire failure.

Pull off the road to a safe location as soon as possible if any tire displays as amber or red. Avoid any sudden steering maneuvers or abrupt braking.

If the TPMS issues a warning when all tires are properly inflated, have the vehicle checked at an authorized Freightliner facility.

Repair a flat tire as soon as possible.

20.11 Lifting and Lowering the Vehicle

20.11.01 Raising a Vehicle with Air Suspension

1. Park the vehicle on a level surface, set the parking brakes, and shut down the vehicle. Chock the tires.



WARNING:

Remove the air from the suspension. Failure to remove the air from the suspension may cause the vehicle to move or shift on the jack stands as air pressure drains from the system; this could cause the vehicle to fall, resulting in damage to the vehicle, serious injury, or death.

2. Exhaust all air from the air suspension.

**WARNING:**

Do not use bottle jacks to raise the vehicle. Always use floor jacks.

Bottle jacks can slip, allowing the vehicle to fall, which could result in damage to the vehicle, serious injury, or death.

IMPORTANT: Only lift unloaded vehicles and vehicles disconnected from trailers.

**NOTICE:**

Do not place jack stands under any of the suspension components; doing so could cause suspension component damage. Jack stands can be placed at any point below the axle, including the differential area.

Do not lift the vehicle from the batteries, eCarrier, or frontbox. See Fig.219,, page 277 for an illustration of no lift areas.

3. Place a floor jack under the axle housing, the clamp group, or the frame rail.

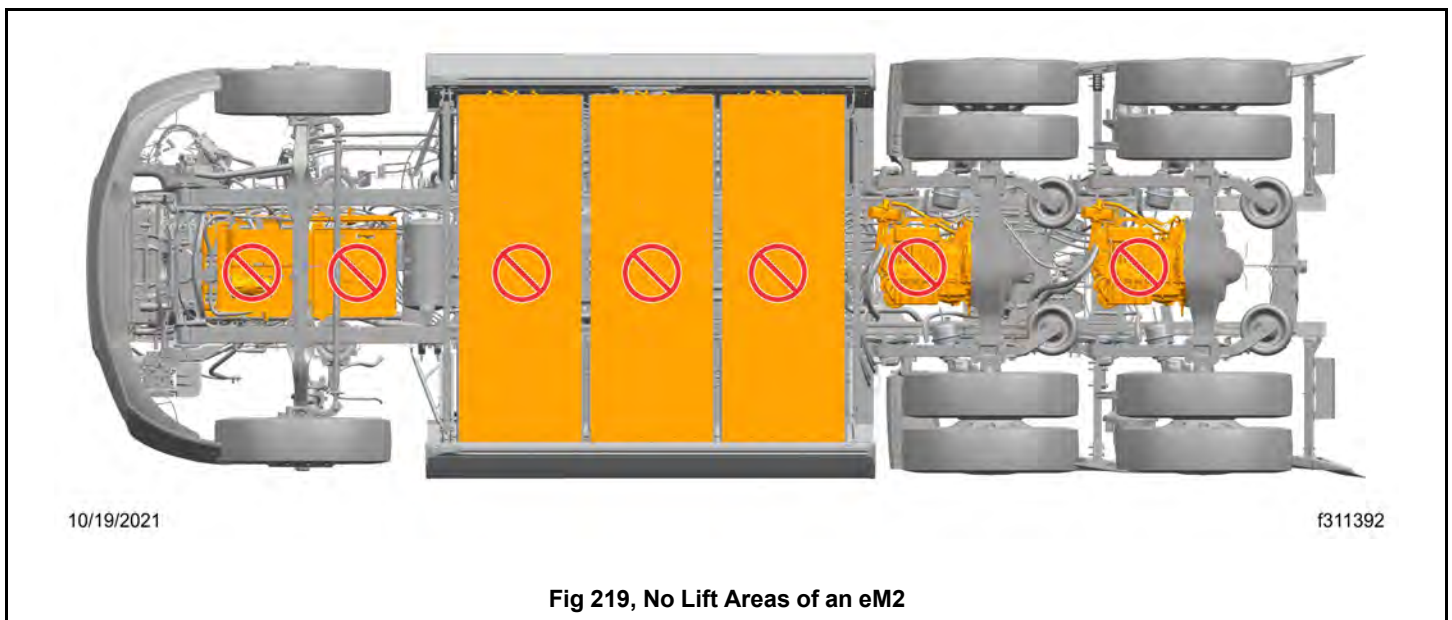

**NOTICE:**

4. Raise the vehicle. Add additional jack stands under the axles as needed to support the vehicle.

20.11.02 Lowering a Vehicle with Air Suspension

**WARNING:**

Do not use bottle jacks to raise the vehicle. Always use floor jacks.
Bottle jacks can slip, allowing the vehicle to fall, which could result in damage to the vehicle, serious injury, or death.

**NOTICE:**

Do not place jack stands under any of the suspension components; doing so could cause suspension component damage.

Jack stands can be placed at any point below the axle, including the differential area.

1. Using a floor jack, raise the vehicle to remove any jack stands used to support the vehicle.
2. Slowly lower the vehicle to the ground.
3. Inflate the air suspension, and check for proper operation. Refer to **Group 32** of the **eM2 Workshop Manual** for instructions.

20.12 Towing the Vehicle

20.12.01 Front Towing Hookup

**WARNING:**

Do not tow an unbraked vehicle if the combined weight of both vehicles is more than the sum of the gross axle weight ratings (GAWR) of the towing vehicle. Otherwise brake capacity will be inadequate, which could result in personal injury or death.

**WARNING:**

Before towing an eM2 all rear axle shafts must be removed. Failure to remove the axle shafts will result in damage to the axle/vehicle, and the driven electric motors may cause induction currents and thus pose an electrical hazard.

If the vehicle is in a location where the drive shafts cannot be removed, the vehicle being rescued may only be towed out of the danger zone for a short distance and at a walking pace. Where possible, the ignition should be switched on and the neutral gear should be engaged. Once the vehicle is out of the danger zone, the drive shafts must be removed. If equipped with an aero bumper, remove before towing, or the bumper will be damaged.

1. Press the eStop button on the dash and secure it with a lock.
2. Lower the stinger assembly so that it is level and approximately 1 inch (0.3 cm) off the ground. Back the tow truck so that the crossbar with lift adaptors is within 6 inches (15 cm) of the aerodynamic bumper. See Fig. 220, [Positioning the Stinger Assembly](#).

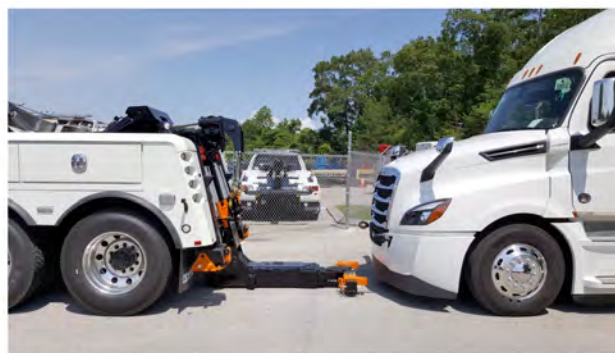

06/07/2022

f130149

Fig 220, Positioning the Stinger Assembly

**NOTICE:**

When using tow loops to move the vehicle, do not pass a sling (for example, a rope or chain) from one loop to another. Known as reeving, this practice is **not** permissible in most industrial applications of towing and hoisting. Reeving can overload the loops and result in damage to the vehicle. See Fig.221,, page 280. The eM2 should not require the use of tow loops.

3. If the vehicle requires lifting ,
pull the tow cables out of the tow truck and connect the tow cable lifting hooks onto the tow loops, then extend the recovery boom within 4 to 6 inches (10 to 15 cm) of being vertical of the tow loops. See Fig. 222, [Tow Cables Connected to the Tow Loops](#).



09/21/2017

f311215

IMPORTANT: Do not reeve when towing.

1. Tow Loop

2. Chain

Fig 221, Reeving

4. Lift the front of the truck until there is enough clearance for the stinger and crossbar to pass under the bumper. See Fig.223, [Moving the Stinger and Crossbar Under the Bumper](#).

If enough clearance cannot be gained with a single lift, jack stands or other means capable of supporting the weight on the front axle must be used while the cables are shortened to allow a second lift.



06/14/2017

f130150

Fig 222, Tow Cables Connected to the Tow Loops



06/14/2017

f130151

Fig 223, Moving the Stinger and Crossbar Under the Bumper



WARNING:

Failure to chock the tires or connect the tow truck's air brake system before releasing the spring parking brakes could allow the disabled vehicle to suddenly roll. This could cause property damage or personal injury.

5. Chock the rear tires.

**WARNING:**

Before towing an eM2 all rear axle shafts must be removed. Failure to remove the axle shafts will result in damage to the axle/vehicle, and the driven electric motors may cause induction currents and thus pose an electrical hazard.

If the vehicle is in a location where the drive shafts cannot be removed, the vehicle being rescued may only be towed out of the danger zone for a short distance and at a walking pace. Where possible, the ignition should be switched on and the neutral gear should be engaged. Once the vehicle is out of the danger zone, the drive shafts must be removed.

6. Remove all rear axle shafts.

For any axle shaft that has been removed, cover the ends of the hubs with metal plates or plywood cut to fit the axle opening and drilled to fit the axle shaft studs. This prevents lubricant from leaking out and will keep contaminants from getting into and damaging the wheel bearings and axle lubricant.

7. Use mid-rise or high-rise forks, or lift adaptors (part number 0200020) on the crossbar to provide clearance for the aerodynamic bumper. See Fig.224, [Lift Adaptors Installed on the Crossbar](#).



Fig 224, Lift Adaptors Installed on the Crossbar

8. Extend the stinger and place the lift adaptors under the axle. Make certain the lift adaptors are under the front suspension springs between the U-bolts. See Fig.225, [Positioning the Stinger with Lift Adaptors Under the Axle](#).

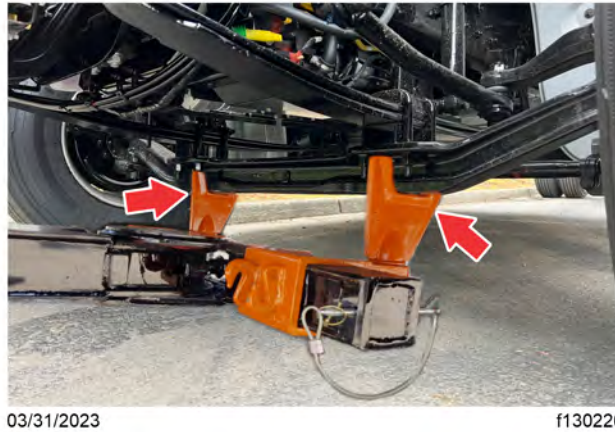

Fig 225, Positioning the Stinger with Lift Adaptors Under the Axle



WARNING:

Failure to protect high-voltage (HV) cables from towing chains could cause property damage, severe personal injury, or death.

9. Secure the vehicle axle to the tow truck crossbar with a chain or ratchet strap.
10. Back the tow truck under the front axle.
11. Retract the recovery boom. See Fig.226, [Retracting the Recovery Boom](#).



Fig 226, Retracting the Recovery Boom

12. Connect the air and electrical supply lines from the tow truck to the truck being towed.

IMPORTANT: On trucks equipped with a front air suspension, either air pressure must be supplied to the secondary air system or the front suspension must be blocked to operating height with wooden spacers and the axle chained to the frame to prevent damage to the truck.

13. Release the park brake and remove the chocks from the rear tires.
14. Use the stinger to pull the truck close to the back of the tow truck for final towing position. See Fig. 227, [Final Towing Position](#).



06/14/2017

f130157

Fig 227, Final Towing Position

15. Connect the safety chains. See Fig. 228, [Safety Chains Connected on the Towed Vehicle](#).



06/14/2017

f130158

Fig 228, Safety Chains Connected on the Towed Vehicle

20.13 Dealing With a Submerged Vehicle

**DANGER:**

Handling a submerged vehicle without appropriate training and personal protective equipment (PPE) could result in serious injury and death.

The removal and de-energizing of a partially or completely submerged vehicle should always be handled by trained emergency responders outfitted with the required PPE.

**WARNING:**

Do not disable the high-voltage system by cutting through an emergency responder cable cut point if the cable is submerged.

Submersion in water (especially salt water) can damage low and high voltage components. Cutting a submerged cable can result in an electrical short and subsequent fire once the vehicle is no longer submerged. This could cause serious injury or death

**WARNING:**

Damaged high voltage batteries can produce flammable gas and fire which can lead to serious injury or death.

Vent the passenger compartment once the vehicle out of the water.

Do not store a recovered vehicle indoors.

The high voltage system of the eM2 is isolated from the chassis. When undamaged, the system will not energize the surrounding water, even when fully submerged.

If in the vehicle when it is submerged, exit the vehicle if it can be done safely. To minimize risk, avoid contact with a submerged high voltage system and batteries. If possible, hit the eStop button on the dash prior to exiting.

When in a safe location, immediately contact emergency services.

Emergency responders will check for damage and, after removing the vehicle from the water, disable the high-voltage system.

21.01 Noise Emissions.....	288
21.02 Greenhouse Gas Emissions.....	289

21. Emissions Information

21.01 Noise Emissions

Every eM2 is equipped with an acoustic vehicle alerting system (AVAS). The AVAS makes the minimum noise possible to alert pedestrians, bicyclists, and other non-motorized road users of the presence and approach of the vehicle.

Each vehicle is equipped with two AVAS speakers. One is located at the front of the vehicle, see Fig. 229, [Location of Front AVAS Speaker](#) and the other is attached on the inside rear of the right-hand frame rail. The general location of the rear AVAS speaker, see Fig.230, [General Location of Rear AVAS Speaker](#).

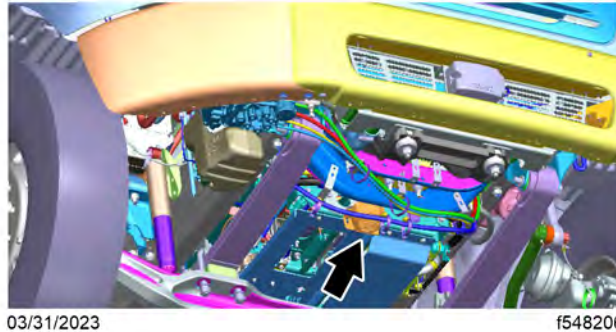

Fig 229, Location of Front AVAS Speaker

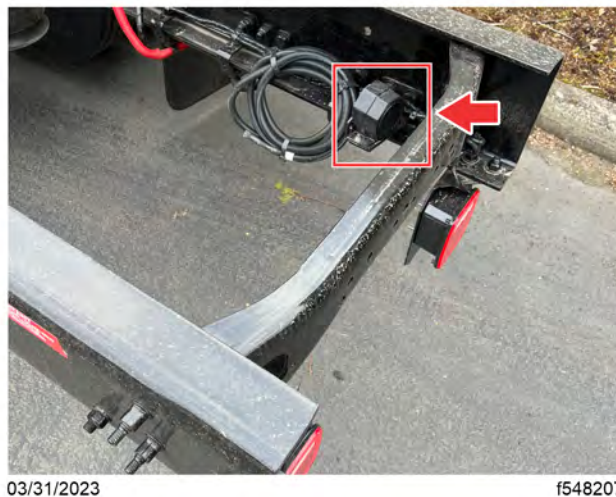

Fig 230, General Location of Rear AVAS Speaker

Each vehicle has a defined AVAS sound, built upon the vehicle noise profile, which cannot be adapted to personal preferences.

The AVAS generates noise when the key is in the ON position and the park brake is released. While driving or when the vehicle is in neutral, sound is broadcast through the front speaker. When the vehicle is in reverse, sound is broadcast through the rear speaker.

When speeding up, the volume of the AVAS sound increases until maximum volume is reached at about 19 mph (30 km/h). This volume is maintained until approximately 60 mph (97 km/h) at which point it turns off. It turns on again when the vehicle slows down to around 20 mph (32 km/h).

The rear speaker will broadcast a beeping sound when the vehicle is in reverse. If the vehicle has been ordered with a back-up alarm, this beep will sound like an electric alarm clock. If the vehicle is ordered with no backup alarm, the reverse beep alert will sound like someone regularly striking a high-pitched key on a piano. The back-up volume is set by the factory and cannot be changed; vehicle speed does not affect the back-up sound volume.

Any deactivation of AVAS imperils the safety of other road users and is strongly discouraged.

21.02 Greenhouse Gas Emissions

Model year 2013 and later vehicles must meet requirements as specified by EPA10, GHG14, GHG17 and GHG21 regulations. See Table 1.1 and Table 1.2 in see [3.01 Component Information Label](#) for additional information on what EPA and GHG regulations apply to different eM2 model years.

Model year 2013 and later vehicles are equipped with components that increase energy efficiency such as low-rolling resistance tires, vehicle speed limiters, and aerodynamic devices such as the hood, cab side extenders, and chassis side fairings.

It is a violation of U.S. federal law to alter components that would bring the vehicle out of compliance with certification requirements [Ref: 42 U.S.C. S7522(a) (3)]. It is the owner's responsibility to maintain the vehicle so that it conforms to all EPA regulations.

22.01 Telematics Information and Terms of Use	292
22.01.01 General Description	292
22.01.02 Telematics Information We Collect and Why We Collect it	292
22.01.03 What We Do With Telematics Information and Who We Share it With	293
22.01.04 Collection Method	293
22.01.05 Safeguards	293
22.01.06 Your Consent	293
22.01.07 Your Rights	293
22.01.08 Privacy Statement Changes	294
22.02 Frequency Bands and Maximum Transmission Output	294
22.02.01 Wireless Applications on the Vehicle	294
22.02.02 The Common Telematics Platform	294

22. Telematics Information

22.01 Telematics Information and Terms of Use

22.01.01 General Description

Your vehicle may be equipped with one or more devices that gather certain information (listed below) about the vehicle and the environment in which it is operating. These devices may periodically send this information ('telematic information') to Daimler Truck North America LLC (DTNA). Additionally DTNA and its dealers may manually retrieve 'telematics information' from devices on the vehicle for the purposes described below.

22.01.02 Telematics Information We Collect and Why We Collect it

The 'telematics information' we collect may include, but is not limited to, the following information about the vehicle:

- performance
- operation
- location
- speed
- trips
- travel history
- stop and idle times
- fuel consumption
- fault codes
- diagnostic information
- steering performance
- braking performance
- air bag deployment
- seatbelt use
- decelerations
- other information relating to the performance, operation, health and safety of the vehicle.

DTNA gathers this information to improve the performance, operation, health and safety of your vehicle and other DTNA vehicles and products. Information is gathered:

- **To enable your subscription services.** DTNA and other third party service providers have developed a variety of applications and services that are now available to you to optimize the performance, use, reliability and safe operation of your vehicle. These services are enabled by the telematics information we receive from your vehicle and will likely be made more effective in the future by the use of that telematics information and similar information we receive from other DTNA vehicles.
- **To make your vehicle safer and to improve its performance.** Depending on the type of devices installed on your vehicle, DTNA may periodically update your vehicle's on-board software to improve the performance and safe use of the vehicle. We may need to obtain certain telematics information to ensure the effectiveness of these updates.
- **To monitor and manage the health and efficiency of your vehicle.** Telematics information from your vehicle may be used by DTNA and its affiliates, dealers, and service providers to more effectively diagnose and resolve problems with your vehicle and to help you maintain it.
- **To improve your customer service experience.** Telematics information may be used by DTNA and its affiliates, dealers, and service providers to provide you a more efficient and effective customer service experience in conjunction with vehicle service, maintenance, field service campaigns and recalls.

- **For product development and product improvement.** Telematics information may be analyzed and used to identify and resolve performance and safety issues and to develop improvements to our products that will benefit you and our future customers.
- **To develop more meaningful product marketing.** Telematics information may be used to provide more customized and meaningful information to our customers regarding products and services that best satisfy their operational requirements and improve the performance of their businesses.
- **To help match our customers with the right products.** Telematics information may be used to develop future products and services that best satisfy the operational requirements of our customers.

22.01.03 What We Do With Telematics Information and Who We Share it With

DTNA may use telematics information for any purpose allowed by law, including but not limited to using the information for any of the purposes described in this chapter. DTNA may share telematics information with its service providers, affiliates, subsidiaries, dealers, and distributors, but only for lawful business purposes. This may include third parties who process information on behalf of DTNA, third parties who you authorize directly to receive information from us, and law enforcement agencies pursuant to applicable law.

DTNA may also combine telematics information it obtains from your vehicle with data from others, anonymize and de-identify that aggregated data, and use and disclose that aggregated data and derivatives of it indefinitely and for any purpose whatsoever, including sharing it with third parties for any purpose without restriction. DTNA will be the exclusive owner of all rights, title and interests in and to all aggregated data. You will not have any rights in any aggregated data or any derivatives or proceeds of it. DTNA shall not have any obligation to provide any aggregated data to you or to compensate you for any use or disclosure of any aggregated data.

22.01.04 Collection Method

The telematics information may be transmitted automatically or manually from the devices on your vehicle to DTNA or Detroit Diesel Corporation (DDC) through diagnostic tools, including but not limited to DDC DiagnosticLink.

22.01.05 Safeguards

DTNA will use reasonable data security systems and procedures in an effort to protect telematics information from unauthorized use, access, disclosure, distribution, loss or alteration. We do this through physical, electronic and procedural safeguards that are designed to protect the confidentiality, integrity and availability of telematics information. However, no security system is perfect. DTNA cannot guarantee that telematics information will not be hacked, deleted, intercepted, or altered.

DTNA will also require other parties to whom telematics information is disclosed to take reasonable steps to protect the telematics information from unauthorized use, access, disclosure, distribution, loss, or alteration.

22.01.06 Your Consent

By continuing to provide to us, or allowing us to receive or retrieve, telematics information through the devices on your vehicle, you consent to its collection and use as described in this chapter.

Although some information may be transferred to and processed in countries without laws providing the same level of data protection as your country, our use and disclosure of your information is subject to these terms of use regardless of where your information is transferred.

If you have subscribed to a subscription service such as Virtual Technician or Detroit Analytics, the Telematics Terms and Conditions for that service will apply to DTNA's collection, storage, use, and sharing of the data covered by those Telematics Terms and Conditions.

22.01.07 Your Rights

You may ask DTNA to discontinue receiving and retrieving telematics information from the devices on your vehicle. If you do so, you will be unable to receive telematics subscription services relating to your vehicle and remotely receive important vehicle software updates, among other things. If you are interested in that option, please contact DTNA at: **DetroitConnect@Daimler.com**.

22.01.08 Privacy Statement Changes

DTNA reserves the right to amend these terms of use from time to time. Changes will be reflected in the online version of this document, which can also be found at: <https://dtnacontent-dtna.prd.freightliner.com/content/dtna-servicelit/search/home-page.html>. **By continuing to provide to us, or allowing us to receive or retrieve, Telematics Information through the devices on your vehicle, you consent to and accept those changes.**

NOTE: These terms of use do not apply to aftermarket telematics devices that may be provided by others or configured to send information to someone other than DTNA or its affiliates, dealers or service providers.

22.02 Frequency Bands and Maximum Transmission Output

22.02.01 Wireless Applications on the Vehicle

Frequency Bands and Maximum Transmission Output			
Component	Service	Frequency Band	Transmission Output
CTP2019DTNA	4G LTE	LTE FDD Band 2 LTE FDD Band 4 LTE FDD Band 5 LTE FDD Band 7 LTE FDD Band 17	0.25 W (Power Class 3)
	3G UMTS/HSDPA/HSUPA	UMTS Band 1 UMTS Band 2 UMTS Band 4 UMTS Band 5 UMTS Band 8	0.25 W (Power Class 3)
	2G GSM/GPRS/EDGE	GSM 850 MHz E-GSM 900 MHz	2 W (Power Class 4)
		DCS 1800 MHz PCS 1900 MHz	1 W (Power Class 1)
	WLAN (IEEE 802.11b)	2.4 GHz band	20 mW
	WLAN (IEEE 802.11g/n)	2.4 GHz band	20 mW
	Bluetooth	2.4 GHz band	10 mW
	GPS / GLONASS	1575 and 1602 MHz	Receive only

Table 15, Frequency Bands and Maximum Transmission Output

22.02.02 The Common Telematics Platform

The Detroit Connect Platform is the connectivity module of Daimler Trucks North America. It receives and transmits data in real time and is the interface for all connectivity-related services. Both the Detroit Connect Platform and a valid agreement is required for use of the Detroit Connect services.

Vehicle antennas (WLAN/BT/CellularNetworks) are located inside and behind the dashboard on the passenger side. In both locations, the shortest possible distance between the antennas and any human or animal body part inside the vehicle cabin is greater than 8 in (20 cm).

Therefore Daimler Trucks North America LLC declares that the radio equipment type CTP2019DTNA is in compliance with Directive 2014/53/EU.



CONTACT INFORMATION

For questions, please create a Service Technical Request using the DTTS Application on the DTNA Portal.