



New Cascadia Driver's Manual

**Models: PE116 DC
PE116 SLP
PE126 DC
PE126 SLP**

Table of Contents

| | |
|---|-----|
| 1. Foreword..... | 5 |
| 2. Vehicle Identification | 9 |
| 3. Vehicle Access | 29 |
| 4. Instruments | 49 |
| 5. Driver Controls | 159 |
| 6. Detroit Assurance 4.0..... | 193 |
| 7. Detroit Assurance | 209 |
| 8. Driver Assistance Features..... | 257 |
| 9. Climate Controls | 301 |
| 10. Seats and Restraints | 311 |
| 11. Cab and Sleeper Features | 327 |
| 12. Electrical System | 337 |
| 13. Engine Starting, Operation, and Shutdown..... | 355 |
| 14. Optional Engine Systems..... | 365 |
| 15. Emissions and Fuel Efficiency..... | 373 |
| 16. Brake Systems | 387 |
| 17. Steering System | 403 |
| 18. Automated and Automatic Transmissions | 405 |
| 19. Manual Transmissions and Clutch..... | 435 |
| 20. Drive Axles | 439 |
| 21. Fifth Wheels | 447 |
| 22. Trailer Couplings..... | 465 |
| 23. Headlights | 469 |
| 24. Vehicle Appearance and Care..... | 479 |
| 25. Pre- and Post-Trip Checklists..... | 485 |
| 26. Pre- and Post-Trip Inspections and Maintenance..... | 491 |
| 27. In An Emergency | 515 |
| 28. Telematics Data | 531 |

| | |
|---|---|
| 1.01 Customer Assistance Center..... | 6 |
| 1.02 Environmental Concerns and Recommendations | 6 |
| 1.03 Data Logging | 6 |
| 1.04 Emissions and Fuel Efficiency Compliance..... | 6 |
| 1.05 Reporting Safety Defects | 6 |

1. Foreword

1.01 Customer Assistance Center

Having trouble finding service? Call the Customer Assistance Center at 1-800-385-4357 or 1-800-FTL-HELP. For dealer referrals and breakdown support, call night or day, weekdays or weekends. For specification requests and all other concerns and inquiries, the Customer Assistance Center is available 5:00 A.M. to 4:00 P.M. PST Monday through Friday. Our people are knowledgeable, professional, and committed to following through to help you keep your truck moving.

1.02 Environmental Concerns and Recommendations

Whenever you see instructions in this manual to discard materials, you should first attempt to reclaim and recycle them. To preserve our environment, follow appropriate environmental rules and regulations when disposing of materials.

1.03 Data Logging

This vehicle is equipped with a control module that performs data logging capabilities.

This vehicle is equipped with one or more devices that record specific vehicle data and may perform some of the same functionality as a regulated Event Data Recorder but the device(s) are not subject to, nor designed pursuant to, 49 C.F.R. Part 563.

The type and amount of data recorded varies depending on how the vehicle is equipped (such as the brand of engine, if an air bag is installed, or if the vehicle features a collision avoidance system, etc.). GPS location data, fault codes, and other technical data may be recorded.

This data may help provide a better understanding of the circumstances of a crash.

Personal data such as name, gender, and age are not recorded. However, other parties such as law enforcement, could combine the data logger's contents with the type of personally identifying data routinely acquired during a crash investigation.

1.04 Emissions and Fuel Efficiency Compliance

This vehicle must be regularly inspected and maintained as indicated in the **New Cascadia Maintenance Manual**, and in the **Pre- and Post-Trip Inspections and Maintenance** chapter in this manual, in order to continue satisfactory performance and ensure coverage of the vehicle under the manufacturer's warranty.

Many maintenance procedures ensure that the vehicle and engine continue to comply with applicable emissions standards. Maintenance procedures, using components engineered to comply with greenhouse gas emissions and fuel efficiency regulations, may be performed by an authorized Daimler Truck North America dealer, an independent outlet, or the vehicle owner or operator.

The vehicle owner is responsible for determining the suitability of replacement components to maintain compliance with federal and local jurisdictional regulations. Components including, but not limited to, low-rolling resistance tires are specifically designed and manufactured to exacting standards for regulatory fuel efficiency and greenhouse gas emissions compliance. It is important that these components are always replaced with components that meet or exceed the performance of the originally installed components.

1.05 Reporting Safety Defects

Vehicles domiciled in the USA thought to have a defect that could cause a crash, injury, or death, should immediately be reported to the National Highway Traffic Safety Administration (NHTSA) and Daimler Truck North America LLC.

If the NHTSA receives similar complaints, it may open an investigation; if it finds that a safety defect exists in a group of vehicles, it may order a recall and remedy campaign. However NHTSA cannot become involved in individual problems between you, your dealer, or Daimler Truck North America LLC.

To contact NHTSA, call the Vehicle Safety Hotline toll-free at 1-888-327-4236 (TTY: 1-800-424-9153).

To e-mail NHTSA, go to www.safertruck.gov/.

You can contact NHTSA by mail at: Administrator, NHTSA Headquarters, 1200 New Jersey Avenue SE, West Building, Washington, DC 20590.

For more information about motor vehicle safety, go to www.safertruck.gov/.

To contact Freightliner about a concern about a specific vehicle call the Customer Assistance Center at 1-800-385-4357 or complete a Product Concern Form.

Vehicles domiciled in Canada thought to have a defect that could cause a crash, injury, or death, should immediately be reported to Transport Canada and Daimler Truck North America LLC.

If Transport Canada receives similar complaints, it may open an investigation; if it finds that a safety defect exists in a group of vehicles, it may order a recall and remedy campaign. However, Transport Canada cannot become involved in individual problems between you, your dealer, or Daimler Truck North America LLC.

To contact Freightliner about a concern about a specific vehicle call the Customer Assistance Center at 1-800-385-4357 or complete a Product Concern Form.

To contact Transport Canada, call the Defect Investigations and Recalls Division toll-free in Canada at 1-800-333-0510 or 819-994-3328 in the Gatineau-Ottawa area or internationally.

You can also contact Transport Canada by mail at: Transport Canada, 330 Sparks Street, Ottawa, Ontario, K1A 0N5 Canada.

The following websites contain more information on Canadian recalls:

English: www.tc.gc.ca/recalls.

French: www.tc.gc.ca/rappels.

For additional road safety information, please visit the Road Transportation website:

English: www.tc.gc.ca/en/services/road

French: www.tc.gc.ca/fr/services/routier

© 2016–2023 Daimler Truck North America LLC. All rights reserved. Daimler Truck North America LLC is a Daimler company.

No part of this publication, in whole or part, may be translated, reproduced, stored in a retrieval system, or transmitted in any form by any means, electronic, mechanical, photocopying, recording, or otherwise, without the prior written permission of Daimler Truck North America LLC. For additional information, please contact Daimler Truck North America LLC, Service Systems and Documentation, P.O. Box 3849, Portland OR 97208–3849 U.S.A. or see <https://northamerica.daimlertruck.com/> and <https://freightliner.com/>.

| | |
|--|----|
| 2.01 Component Information Label | 10 |
| 2.02 Component GWR Label..... | 11 |
| 2.03 Federal Motor Vehicle Safety Standard Label | 13 |
| 2.04 Canada Certification Label | 15 |
| 2.05 Mexico Labeling | 16 |
| 2.05.01 Mexico Certification Label..... | 16 |
| 2.05.02 Spanish Weights and Measures Label..... | 18 |
| 2.06 Emissions Labels | 19 |
| 2.06.01 Aftertreatment System Indicators Label | 19 |
| 2.06.02 Vehicle Emission Control Information Label | 21 |
| 2.06.03 Noise Emission Control Labels..... | 23 |
| 2.06.04 Certified Clean Idle Label | 25 |
| 2.07 Customer Assistance Label..... | 25 |

2. Vehicle Identification

2.01 Component Information Label

NOTE: Labels shown in this chapter are examples only. Actual specifications may vary from vehicle to vehicle.

The component information label lists the vehicle model, identification number, and major component models and serial numbers.

For vehicles domiciled in Mexico, this label will be in Spanish as shown in Fig.1, [Component Information Label \(Spanish\)](#). Otherwise it will be printed in English as shown in Fig.2, [Component Information Label \(English\)](#).



INFORMACION DE COMPONENTES

USE EL NUMERO DE IDENTIFICACION DE VEHICULO CUANDO ORDENE PARTES.

| | | |
|--|----------------------------|------------------------|
| FABRICADO POR: DAIMLER VEHICULOS COMERCIALES MEXICO | | FECHA DE FABRIC: 06/20 |
| MODELO: MM106064S | MODELO BASE: M2106 | DIST. ENTRE EJE: 230 |
| NO. DE SERIE VEH: 3ALHCYD28MDMN5409 | CLIENTE: V83361 | |
| MOTOR: DD8 7.7L 6 CYL SINGLE STAGE 280 HP / 220 | MOTOR: 936913S0010863 | |
| TRANS PRINCIPAL: ALLISON 3000 RDS AUTOMATIC TRANSMISSION | TRANSMISION: 6511714361 | |
| PTO: DETROIT DA-F-12-0-3 12.000# FF1 71.5 KPI | PTO: 739912B0165864 | |
| EJE DELANTERO: MT-40-14X 40.000# R-SERIES TANDEM REAR A | EJE DELANTERO: DRA21199653 | |
| EJE INT. 1RO: | EJE INT. 1RO: | |
| EJE INT. 2DO: | EJE INT. 2DO: | |
| EJE INT. 3RO: | EJE INT. 3RO: | |
| EJE INT. 4TO: | EJE INT. 4TO: | |
| EJE INT. 5TO: | EJE INT. 5TO: | |
| EJE INT. 6TO: | EJE INT. 6TO: | |
| EJE TRASERO: MT-40-14X 40.000# R-SERIES TANDEM REAR A | EJE TRASERO: DRA21199652 | |
| PROVEEDOR DE PINTURA: ELITE EY PAINT C | RELACION: 6.14 | |
| NO. DE PINTURA: CAB COLOR A: L0006EY | | |

PARA INFORMACION COMPLETA DE PINTURA: VER HOJA DE ESPECIFICACIONES DE L VEHICULO.

09/29/2020

f080196s

Fig 1, Component Information Label (Spanish)



COMPONENT INFORMATION

SEE VEHICLE ID NO. WHEN ORDERING PARTS

| | | |
|--|-----------------------------|--------------------|
| MANUFACTURED BY: DAIMLER TRUCKS NORTH AMERICA LLC | | DATE OF MFR: 07/15 |
| MODEL: PX113064S T | BASE MODEL: CA113DC | WHEELBASE: 164 |
| VEHICLE ID NO: 1FUJGBDV4GLZZ9999 | CUSTOMER: N00000 | |
| ENGINE MOD: DETROIT DD13 12.8L 410 HP / 1800 RPM 20 | ENGINE NO: 9999999999999999 | |
| MAIN TRANS MOD: DT12-DB-1450 HEAVY DUTY 12-SPEED DIRECT | TRANS NO: 9999999999999999 | |
| PTO MOD: MFS-12-143A 12.000# FF1 SINGLE FRONT AXL | PTO NO: MON999999999 | |
| FRONT AXLE MOD: MT-40-14X 40.000# R-SERIES DUALTRAC 74-7 | FRONT AXLE NO: FOR999999999 | |
| 1ST INT AXLE MOD: | 1ST INT AXLE NO: | |
| 2ND INT AXLE MOD: | 2ND INT AXLE NO: | |
| 3RD INT AXLE MOD: | 3RD INT AXLE NO: | |
| 4TH INT AXLE MOD: | 4TH INT AXLE NO: | |
| 5TH INT AXLE MOD: | 5TH INT AXLE NO: | |
| 6TH INT AXLE MOD: | 6TH INT AXLE NO: | |
| REAR AXLE MOD: MT-40-14X 40.000# R-SERIES DUALTRAC 74-7 | REAR AXLE NO: FOR999999999 | |
| PAIN MFR: ELITE BC PAINT C | RATIO: 2.47 | |
| PAIN CODE: CAB COLOR A: L0306EB | | |

FOR COMPLETE PAINT INFORMATION SEE VEHICLE SPECIFICATION SHEET

06/21/2016

f080196

Fig 2, Component Information Label (English)

The component information label is attached to the outside of the ziplock document bag and the right-hand door. See Fig. 3, [Component Information Label Location](#).

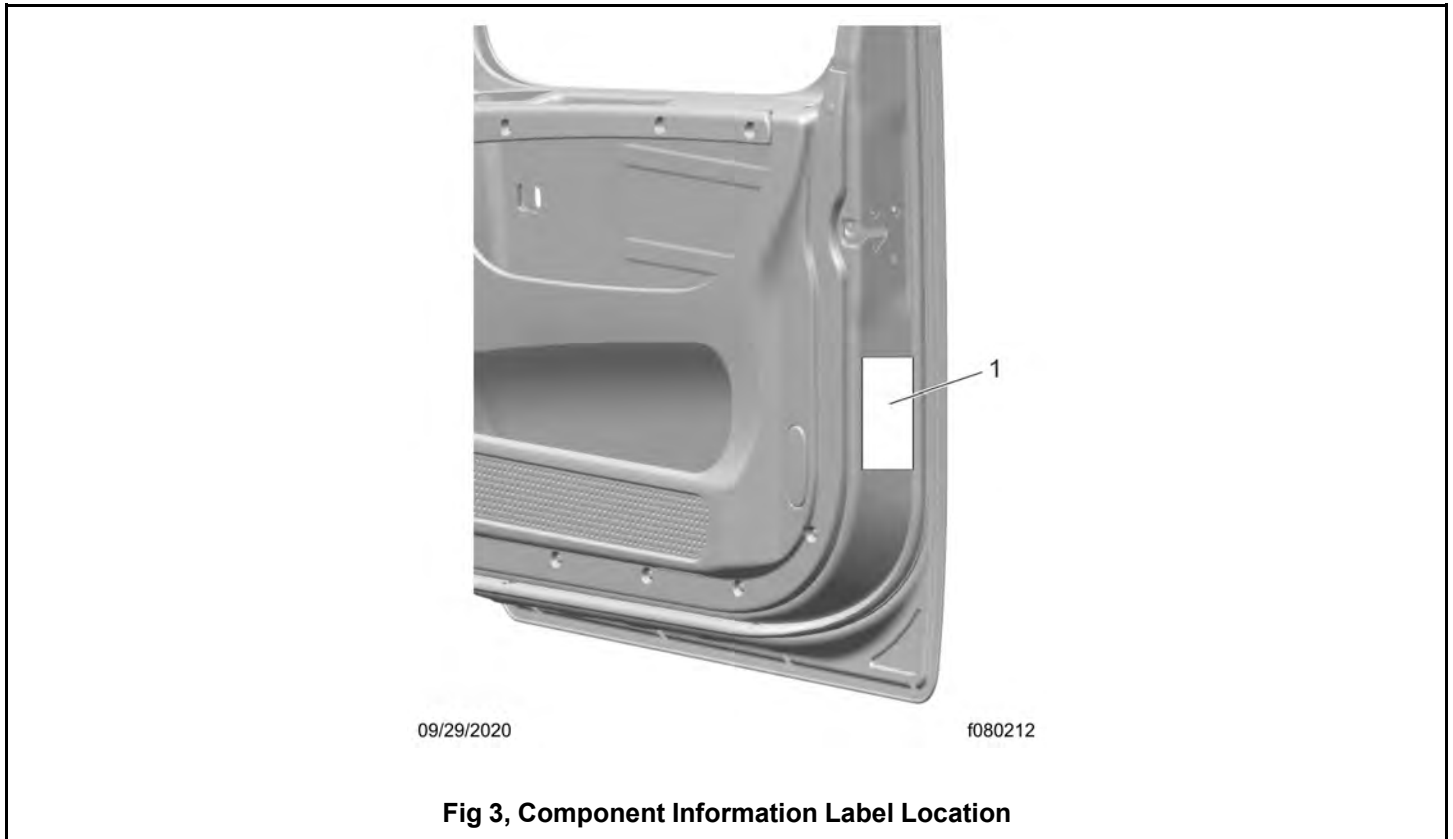

Fig 3, Component Information Label Location

2.02 Component GWR Label

NOTE: Vehicles manufactured for the Canada market will have a Canada Certification label instead of a component GWR label.

The component GWR label (see Fig.4, [Component GWR Label \(English\)](#)) provides maximum GWR ratings for each component. For vehicles domiciled in Mexico, this label will be in Spanish as shown in Fig.5, [Component GWR Label \(Spanish\)](#).

| | | | | | | | | | | | | |
|---|-----------------------------------|--------------|---------------|---------------|--------------|--------------|--------------|--------------|--------------|-----------|----------------|------------------------|
|  | MAXIMUM GWR BY COMPONENT (KG/LBS) | COMPONENT | FRONT AXLE | 1ST INT AXLE | 2ND INT AXLE | 3RD INT AXLE | 4TH INT AXLE | 5TH INT AXLE | 6TH INT AXLE | REAR AXLE | COMPONENT GVWR | |
| | | AXLES: | (5443) 12000 | (9072) 20000 | | | | | | | (9072) 20000 | CHASSIS: |
| | | SUSPENSION: | (5443) 12000 | (9072) 20000 | | | | | | | (9072) 20000 | ENG/TRANS: |
| | | TIRES: | (5601) 12350 | (9253) 20400 | | | | | | | (9253) 20400 | 5TH WHEEL: |
| | | RIMS: | (6713) 14800 | (11612) 25600 | | | | | | | (11612) 25600 | PARK BRAKE: |
| | | HUBS/SPOKES: | (6032) 13300 | (10432) 23000 | | | | | | | (10432) 23000 | AXLE: |
| | | BRAKES: | (6032) 13300 | (9072) 20000 | | | | | | | (9072) 20000 | VIN: 1FUJGBDV4GLZZ9999 |
| | | STEERING: | (6032) 13300 | | | | | | | | | f080200 |
| | | 06/21/2016 | | | | | | | | | | |

Fig 4, Component GWR Label (English)

| FREIGHTLINER | | COMPONENTE DELANTERO PRIMERO 1RO | | | | | | 2DO | 3RO | 4TO | 5TO | 6TO | EJE TRASERO | PESO BRUTO DEL COMPONENTE | |
|--|---------------|----------------------------------|---------------|--|--|--|--|-----|-----|-----|-----|---------------|------------------------|---------------------------|--|
| PESO MAXIMO POR COMPONENTE (KG/LB) | EJE: | (5443) 12000 | (9072) 20000 | | | | | | | | | (9072) 20000 | LARGUERO: | (36288) 80000 | |
| | SUSPENSION: | (5443) 12000 | (9072) 20000 | | | | | | | | | (10596) 23360 | MOTOR/TRANS: | | |
| | NEUMATICOS: | (5996) 13220 | (10596) 23360 | | | | | | | | | (13426) 29600 | QUINTA RUEDA: | | |
| | RIM/AROS: | (6713) 14800 | (13426) 29600 | | | | | | | | | (11793) 26000 | FRENO ESTAC: | | |
| | CUBOS/RADIOS: | (6032) 13300 | (11793) 26000 | | | | | | | | | (9525) 21000 | EJE: | | |
| | FRENOS: | (5443) 12000 | (9525) 21000 | | | | | | | | | | VIN: 3ALHCYD28MDMN5409 | | |
| | DIRECCION: | (6032) 13300 | | | | | | | | | | | | | |
| 09/29/2020 | | | | | | | | | | | | | | f080200s | |

Fig 5, Component GWR Label (Spanish)

The component GWR label is located on the right-hand B-pillar as shown in Fig.6, Label Locations.

09/29/2020

f720776f

- A. Left-Hand B-Pillar
- B. Left-Hand Door
- C. Right-Hand B-Pillar
- 1. Primary Noise Emission Control Label (Mexico or United States)
- 2. Customer Assistance Label (United States or Mexico)
- 3. FMVSS Certification Label or Spanish Weights and Measurement Label
- 4. Canada Certification Label or FMVSS Certification Label
- 5. Entry/Exit Warning Decal
- 6. Vehicle Emission Control Information Label
- 7. Secondary Noise Emission Control Label (English)
- 8. Mexico Certification Label
- 9. Component GWR Label (Spanish or English)

Fig 6, Label Locations

2.03 Federal Motor Vehicle Safety Standard Label

Tractors with or without fifth wheels manufactured for the U.S. are marked as certified by means of an FMVSS certification label which also lists suitable tire and rim combinations. See Fig.8, [FMVSS Vehicle Certification Label \(complete vehicle\)](#) for an example of a FMVSS vehicle certification label.

This label is attached to the left-hand B-pillar. It is applied on the interior edge for vehicles domiciled in the United States or manufactured for U.S./Canada operation. See Fig.7, [Component GWR Label](#).

Tractors built without a fifth wheel for U.S. operations will have an incomplete FMVSS vehicle certification label. The incomplete vehicle documentation included with the vehicle will certify the vehicle conforms to all applicable regulations in effect on the date of completion. The final certification label must be attached by the final-stage manufacturer.

| | | | | | | | | | | | | |
|---|-----------------------------------|--------------|---------------|---------------|--------------|--------------|--------------|--------------|--------------|-----------|----------------|------------------------|
|  | MAXIMUM GWR BY COMPONENT (KG/LBS) | COMPONENT | FRONT AXLE | 1ST INT AXLE | 2ND INT AXLE | 3RD INT AXLE | 4TH INT AXLE | 5TH INT AXLE | 6TH INT AXLE | REAR AXLE | COMPONENT GVWR | |
| | | AXLES: | (5443) 12000 | (9072) 20000 | | | | | | | (9072) 20000 | CHASSIS: |
| | | SUSPENSION: | (5443) 12000 | (9072) 20000 | | | | | | | (9072) 20000 | ENG/TRANS: |
| | | TIRES: | (5601) 12350 | (9253) 20400 | | | | | | | (9253) 20400 | 5TH WHEEL: |
| | | RIMS: | (6713) 14800 | (11612) 25600 | | | | | | | (11612) 25600 | PARK BRAKE: |
| | | HUBS/SPOKES: | (6032) 13300 | (10432) 23000 | | | | | | | (10432) 23000 | AXLE: |
| | | BRAKES: | (6032) 13300 | (9072) 20000 | | | | | | | (9072) 20000 | VIN: 1FUJGBDV4GLZZ9999 |
| | | STEERING: | (6032) 13300 | | | | | | | | | f080200 |
| | | 06/21/2016 | | | | | | | | | | |

Fig 7, Component GWR Label



| | | | | | | | | |
|--|--|---------------------|-----------|----------------|-----------|----------|----------|-----|
|  | MANUFACTURED BY: DAIMLER TRUCKS N.A. LLC | GAWR/PNBE | GAWR/PNBE | TIRES | RIMS | KPA COLD | PSI COLD | "S" |
| | DATE OF MFR: 07/15 | KGS | LBS | | | | | |
| | GVWR/PNBV-KG: 23,587 | FRONT AXLE: 5,443 | 12,000 | 275/80R22.5(G) | 22.5X8.25 | 758 | 110 | S |
| | GVWR/PNBV-LBS: 52,000 | 1ST INT AXLE: 9,072 | 20,000 | 445/50R22.5(L) | 22.5X14.0 | 827 | 120 | S |
| | THIS VEHICLE COMPLIES WITH ALL APPLICABLE FEDERAL MOTOR VEHICLE SAFETY STANDARDS IN EFFECT AT THE DATE OF MANUFACTURE SHOWN ABOVE. | 2ND INT AXLE: | | | | | | |
| | VEHICLE ID NO: 1FUJGBDV4GLZZ9999 | 3RD INT AXLE: | | | | | | |
| | TYPE: TRUCK/TRACTOR TT/CT | 4TH INT AXLE: | | | | | | |
| | COUNTRY OF ORIGIN: U.S.A. | 5TH INT AXLE: | | | | | | |
| | | 6TH INT AXLE: | | | | | | |
| | 08/31/2020 | REAR AXLE: 9,072 | 20,000 | 445/50R22.5(L) | 22.5X14.0 | 827 | 120 | S |
| | | | | | | | f080199 | |

Fig 8, FMVSS Vehicle Certification Label (complete vehicle)

The FMVSS label is applied to the exterior edge of the B-pillar if paired with a Spanish weights and measurements label. See Fig.9, [Label Locations](#). Vehicles domiciled in Mexico are labeled with a Spanish weights and measurement label that lists suitable tire and rim combinations. See Fig.10, [Spanish Weights and Measures Label](#).

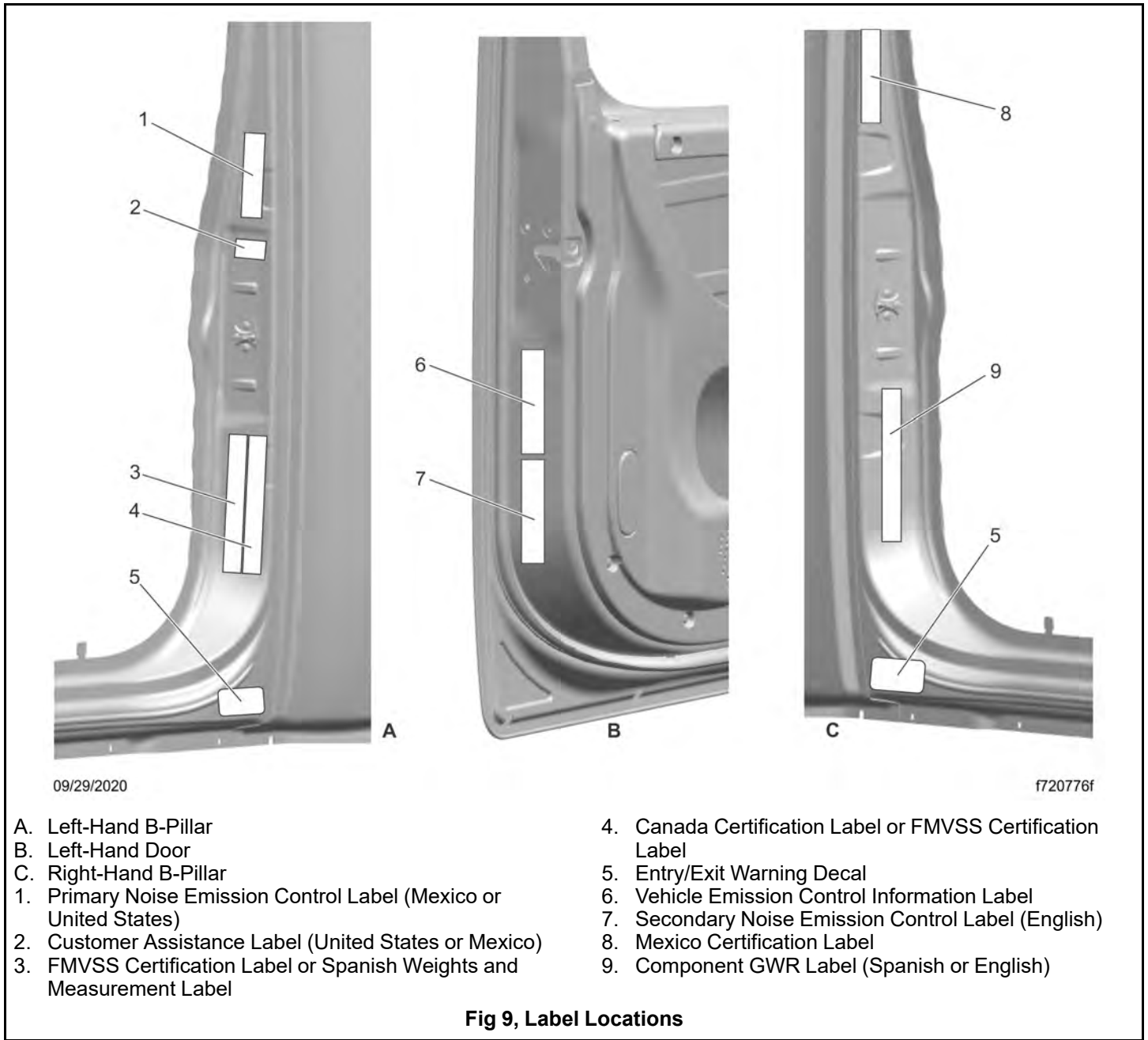

| | | | | | | | | | | |
|---|-----------------------|--------------------------------------|----------------|--------|------------|------------|-----------|-----|---------------------|---------|
|  | FABRICADO POR: | DAIMLER VEHICULOS COMERCIALES MEXICO | PV-KGS | PV-LBS | NEUMATICOS | RIM/AROS | KPA | PSI | *S"ENCILLA/ FRIO | "D"OBLE |
| | FECHA DE FABRICACION: | 06/20 | EJE DELANTERO: | 5,443 | 12,000 | 11R22.5(H) | 22.5X8.25 | 827 | 120 | S |
| | PBV (GVWR)-KG: | 23,587 | 1RO: | 9,072 | 20,000 | 11R22.5(G) | 22.5X8.25 | 724 | 105 | D |
| | PBV (GVWR)-LBS: | 52,000 | 2DO: | | | | | | | |
| | | | 3RO: | | | | | | | |
| | | | 4TO: | | | | | | | |
| | NO. SERIE VEHICULO: | 3ALHCYD28MDMN5409 | 5TO: | | | | | | | |
| | | CHASIS-CABINA | 6TO: | | | | | | | |
| | FABRIC. DE MEX. | | EJE TRASERO: | 9,072 | 20,000 | 11R22.5(G) | 22.5X8.25 | 724 | 105 | D |
| | | | | | | | | | | |

09/29/2020 f080199s

Fig 10, Spanish Weights and Measures Label

The tire and rim combinations listed on these labels are those that can be installed on the vehicle for the given gross axle weight rating. Tires and rims installed on the vehicle at the time of manufacture may have a higher load capacity than that certified by the tire and rim label. If the tires and rims currently on the vehicle have a lower load capacity than that shown on the tire and rim label, then the tires and rims determine the load limitations on each of the axles.

2.04 Canada Certification Label

Complete tractors with fifth wheels manufactured for Canada are marked with a Canada certification label attached to the left-hand B-pillar.

Complete tractors with fifth wheels manufactured for dual Canada/United States operations will have both a FMVSS certification label and Canada certification label. In this case the FMVSS certification label will be applied on the interior edge of the B-pillar and the Canada certification label will be applied on the exterior edge as show in Fig.11, [Label Locations](#).

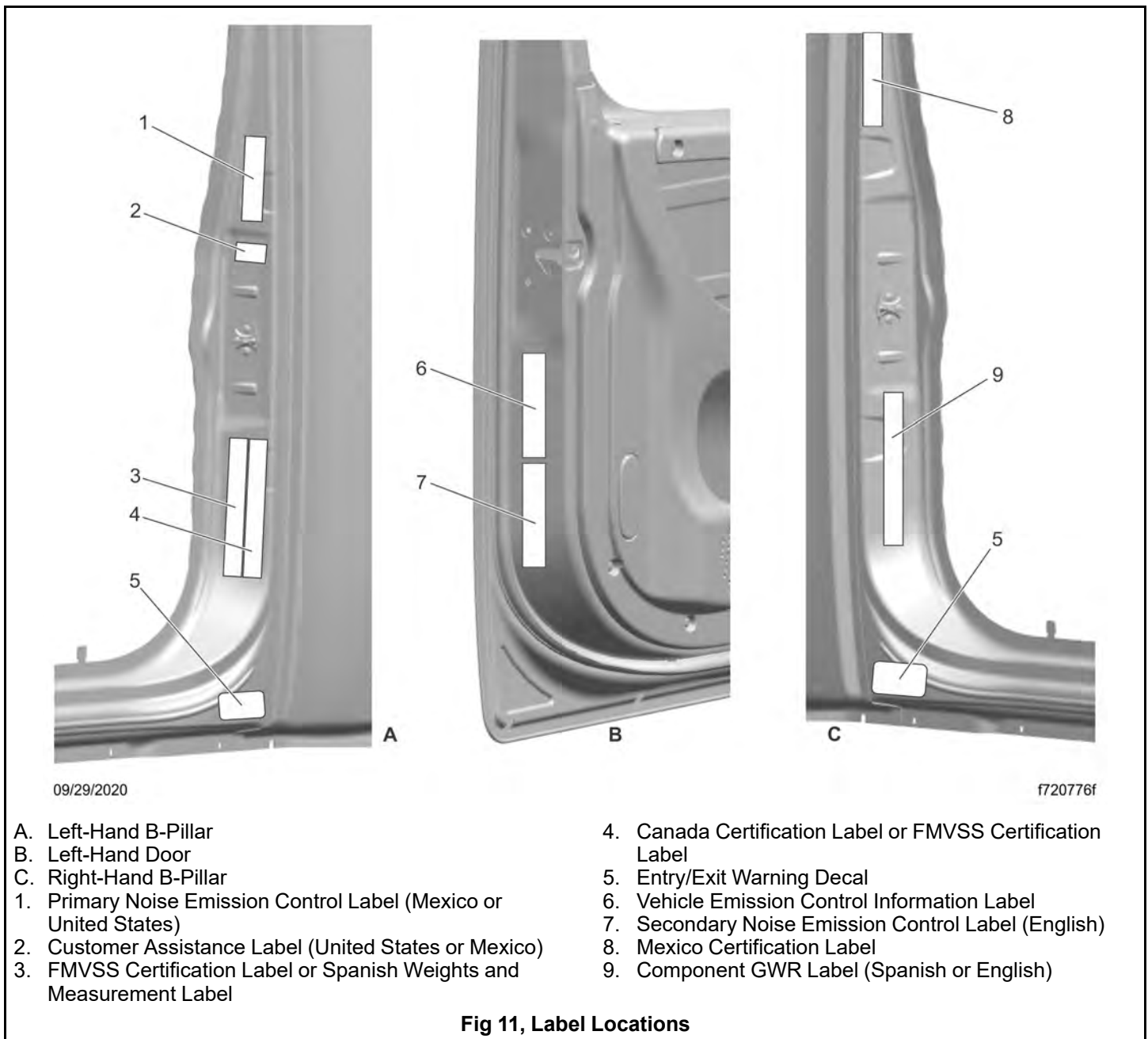

See Fig.12, [Canada Certification Label](#) for an example of a Canada certification label.

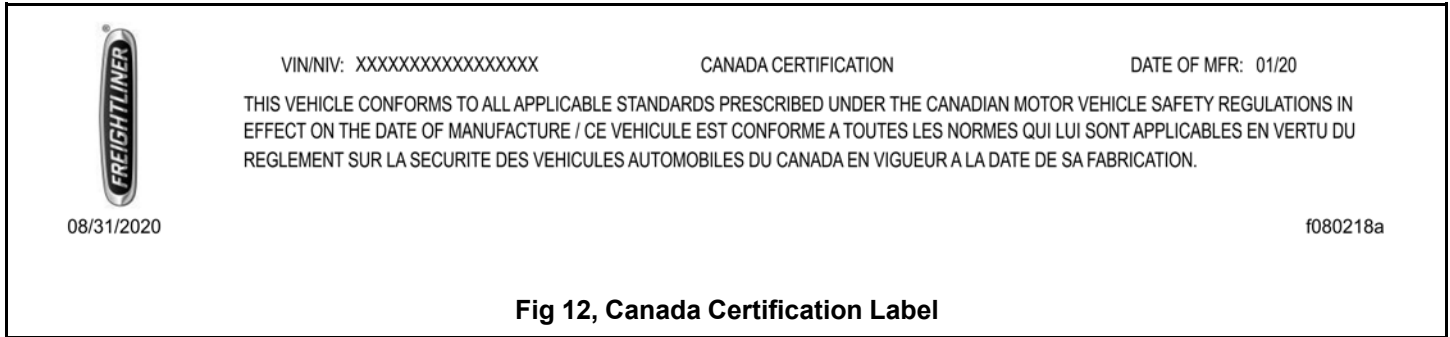

Trucks built without a cargo body and tractors built without a fifth wheel that are intended for service in Canada will have an incomplete Canada vehicle certification label attached to the left-hand B-pillar. After completion of the vehicle, a complete Canada certification label must be attached by the final-stage manufacturer to certify that the vehicle conforms to all applicable vehicle safety regulations in effect on the date of completion.

2.05 Mexico Labeling

2.05.01 Mexico Certification Label

The Mexico certification label states that the vehicle complies with the Normas Oficiales Mexicanas (NOMs) standards in effect on the date the vehicle was manufactured. See Fig.15, [Mexico Certification Label](#).

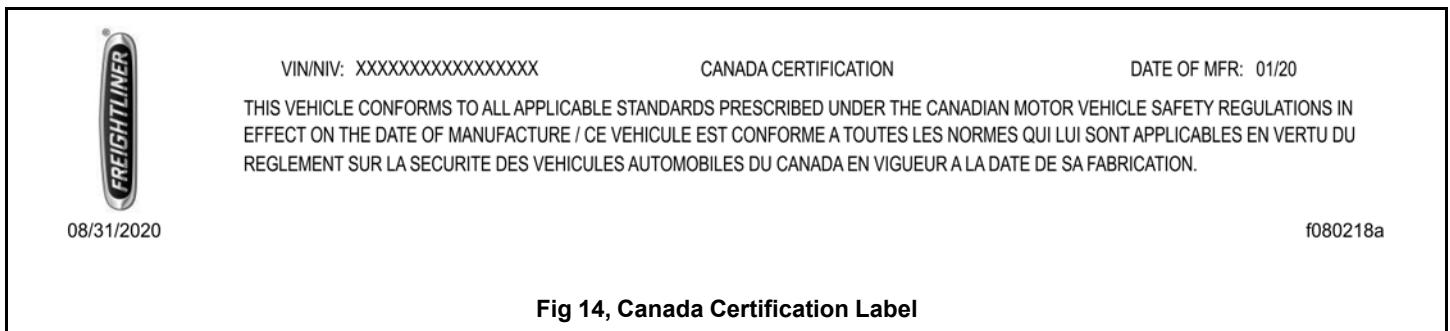
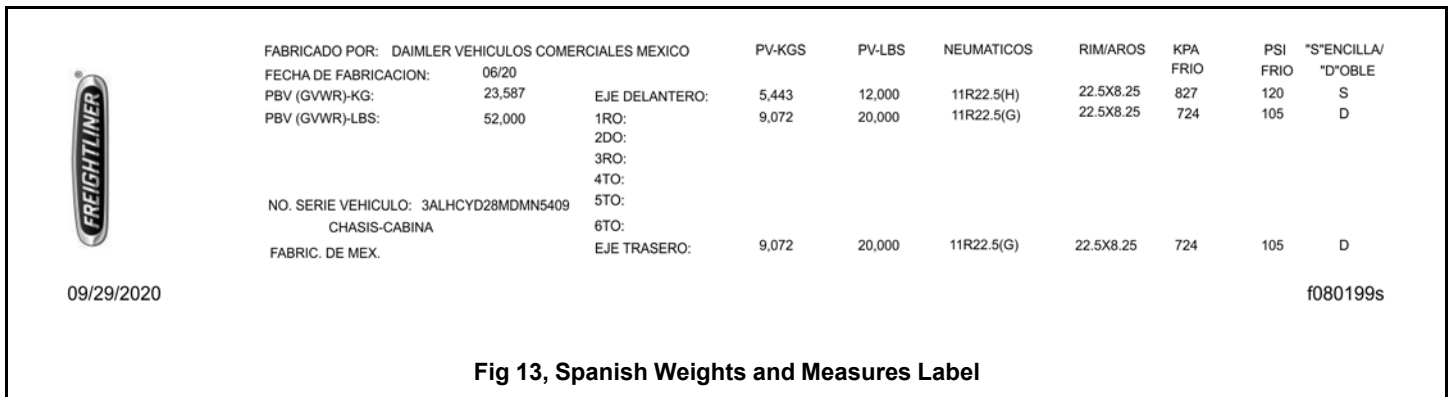
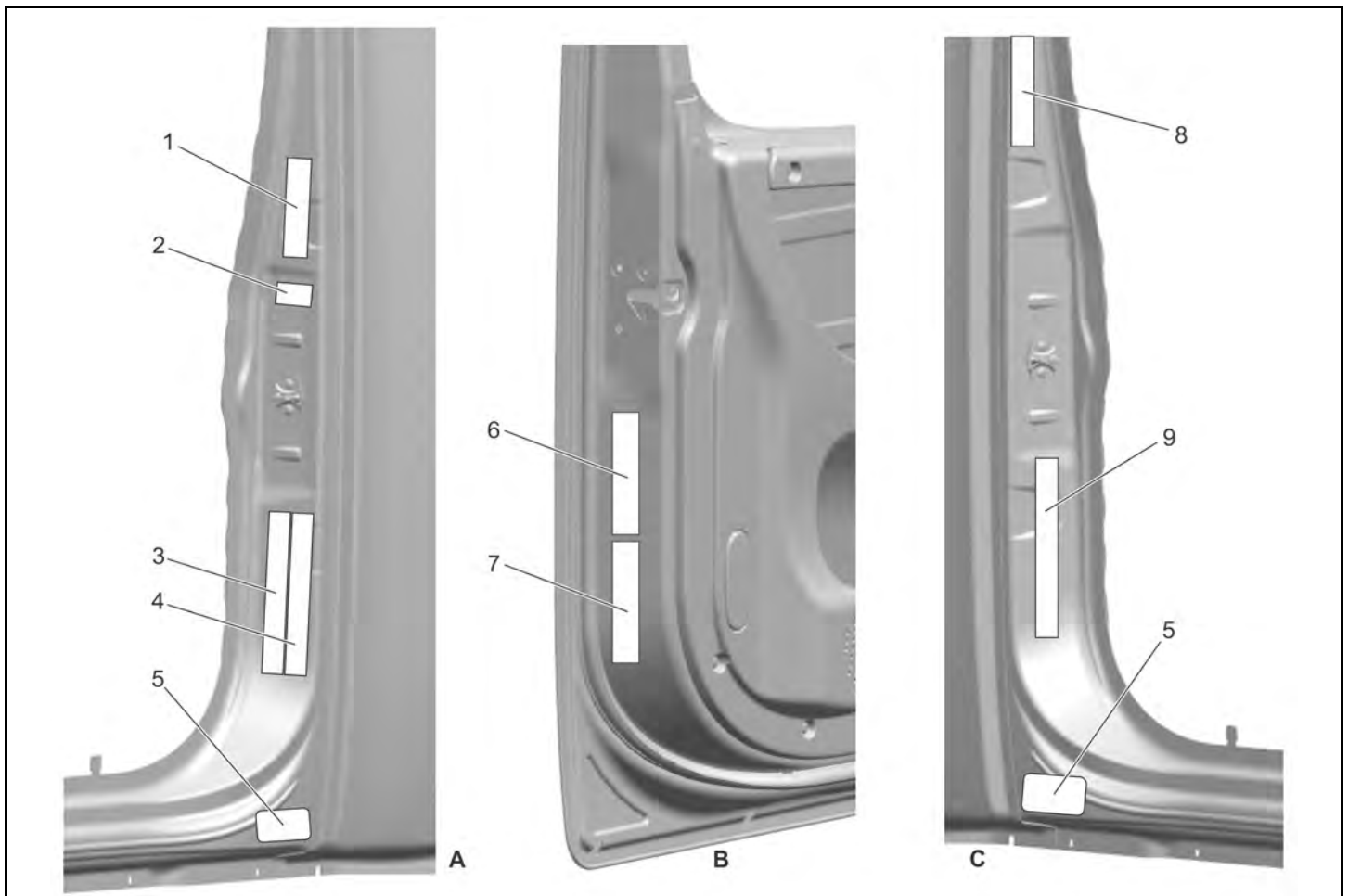



Fig 15, Mexico Certification Label

Vehicles domiciled in Mexico will have a Mexico certification label applied to the right-hand B-pillar as show in Fig. 16, [Label Locations](#).



09/29/2020

f720776f

- A. Left-Hand B-Pillar
- B. Left-Hand Door
- C. Right-Hand B-Pillar
- 1. Primary Noise Emission Control Label (Mexico or United States)
- 2. Customer Assistance Label (United States or Mexico)
- 3. FMVSS Certification Label or Spanish Weights and Measurement Label
- 4. Canada Certification Label or FMVSS Certification Label
- 5. Entry/Exit Warning Decal
- 6. Vehicle Emission Control Information Label
- 7. Secondary Noise Emission Control Label (English)
- 8. Mexico Certification Label
- 9. Component GWR Label (Spanish or English)

Fig 16, Label Locations

2.05.02 Spanish Weights and Measures Label

Vehicles with a Mexico certification label will also have a Spanish weights and measures label. See Fig. 17, [Spanish Weights and Measures Label](#) for an example.

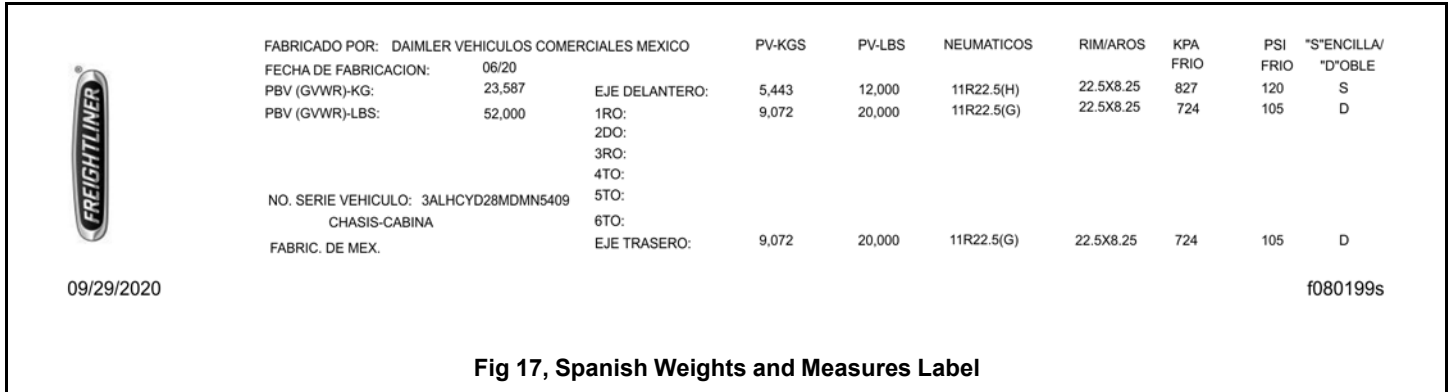

When both a United States Federal Motor Vehicle Safety Standard (FMVSS) label and a Spanish weights and measures label are applied to the left-hand B-pillar, the Spanish label will be applied on the interior edge of the B-pillar and the FMVSS label will be applied on the exterior edge. See Fig. 18, [Label Locations](#).

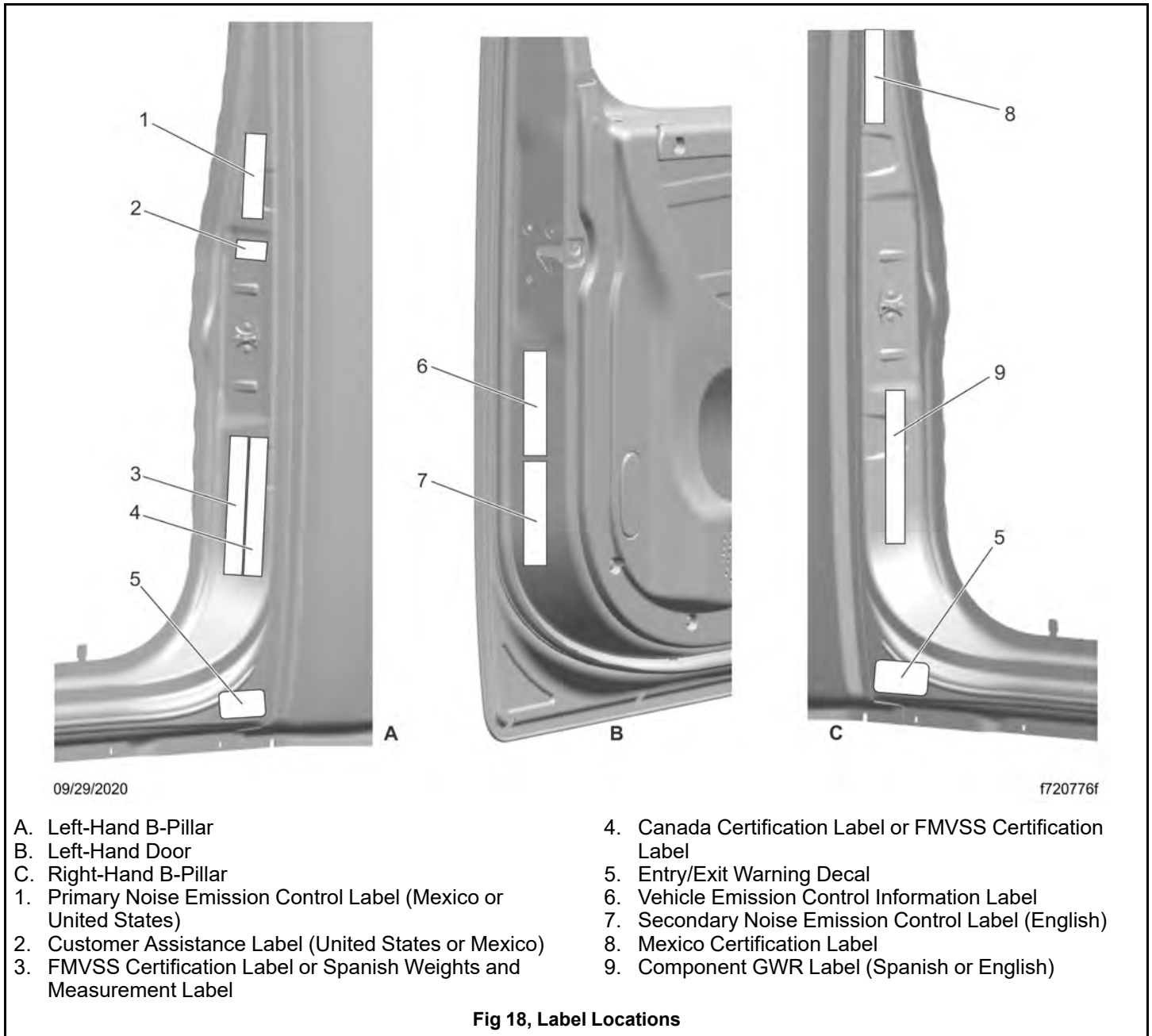

2.06 Emissions Labels

2.06.01 Aftertreatment System Indicators Label

Model year 2007 and later diesel engines in vehicles domiciled in the U.S. or Canada are required to meet all EPA exhaust gas emission regulations effective as per the applicable emission model year, and are equipped with an emission aftertreatment system (ATS).

Vehicles domiciled outside of the U.S. and Canada may not have aftertreatment equipment, depending upon local statutory emissions guidelines.

See Table.1, [EPA Regulations](#) and Table.2, [Emission Regulations by Model Year](#) for additional information on what EPA and GHG regulations apply to different model years.

See Fig. 19, [ATS Indicators](#), [EPA10](#) and [Newer](#) for information on the driver's visor warning label for important warning indicators in the instrument cluster that pertain to the ATS.

| Regulation | Emissions Components |
|---|--|
| EPA07 (Reduction of nitrogen oxides (NOx) emissions to 1.1 g/bhp-hr, and particulate matter emissions to 0.01 g/bhp-hr) | Aftertreatment device (ATD) containing a diesel particulate filter that traps soot and ash. |
| EPA10 (Reduction of NOx emissions to 0.2 g/bhp-hr) | EPA07-type ATD, with additional selective catalyst reduction (SCR) technology that utilizes diesel exhaust fluid (DEF) to convert NOx to nitrogen and water vapor. |
| GHG14 (Reduction of greenhouse gas emissions) | Fuel efficiency components including, but not limited to, engines, tires, aerodynamic components, vehicle speed limiters, and idle reduction timers specifically designed to meet regulatory fuel efficiency and greenhouse gas emissions standards. |
| GHG17 | Fuel efficiency components including, but not limited to, engines, tires, aerodynamic components, vehicle speed limiters, and idle reduction timers specifically designed to meet regulatory fuel efficiency and greenhouse gas emissions standards. |
| GHG21 | GHG14/17 components plus additional components including, but not limited to, transmissions, axles, predictive technologies, idle reduction technologies for vocational vehicles, and tire pressure monitoring systems. |

1. Cummins and Detroit ATD's are also equipped with a diesel oxidation catalyst to break down pollutants.

Table 1, EPA Regulations

| Model Year | Engine Regulation | Vehicle Regulation |
|----------------|-------------------|--------------------|
| 2007—2009 | EPA07 | N/A |
| 2010—2012 | EPA10 | N/A |
| 2013—2015 | EPA10, GHG14 | GHG14 |
| 2016 | EPA10, GHG17 | GHG14 |
| 2017—2020 | EPA10, GHG17 | GHG17 |
| 2021 and later | EPA10, GHG21 | GHG21 |

Table 2, Emission Regulations by Model Year

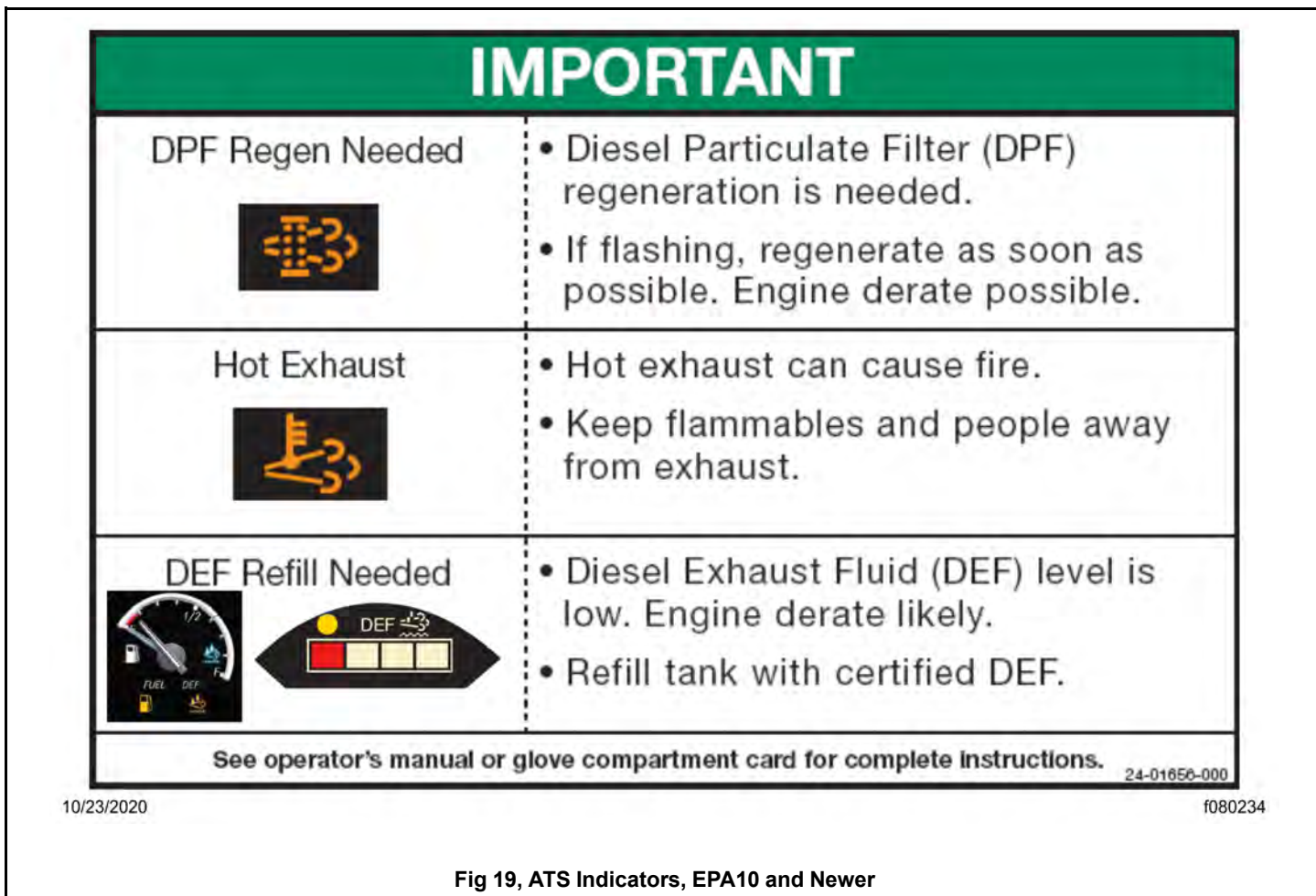

It is a violation of U.S. federal law to alter exhaust plumbing, ATS, or other components in any way that would bring the engine/vehicle out of compliance with certification requirements [Ref: 42 U.S.C. S7522(a) (3)]. It is the owner's responsibility to maintain the vehicle so that it conforms to EPA regulations.

2.06.02 Vehicle Emission Control Information Label

Model year 2013 and later vehicles meet requirements as specified by GHG14, GHG17 and GHG21 regulations, respectively. These vehicles are equipped with components that increase fuel efficiency and reduce greenhouse gas (GHG) emissions. Components may include, but are not limited to, low-rolling resistance tires; aerodynamic devices such as hood, cab side extenders, and fuel tank fairings; vehicle speed limiters; and idle shutdown timers.

A Vehicle Emission Control Information Label is located on the left-hand door. See Fig.20, [Label Locations](#). Among other GHG relevant information the label indicates the emission model year of the vehicle. As this label is about meeting United States federal requirements, it is printed in English.

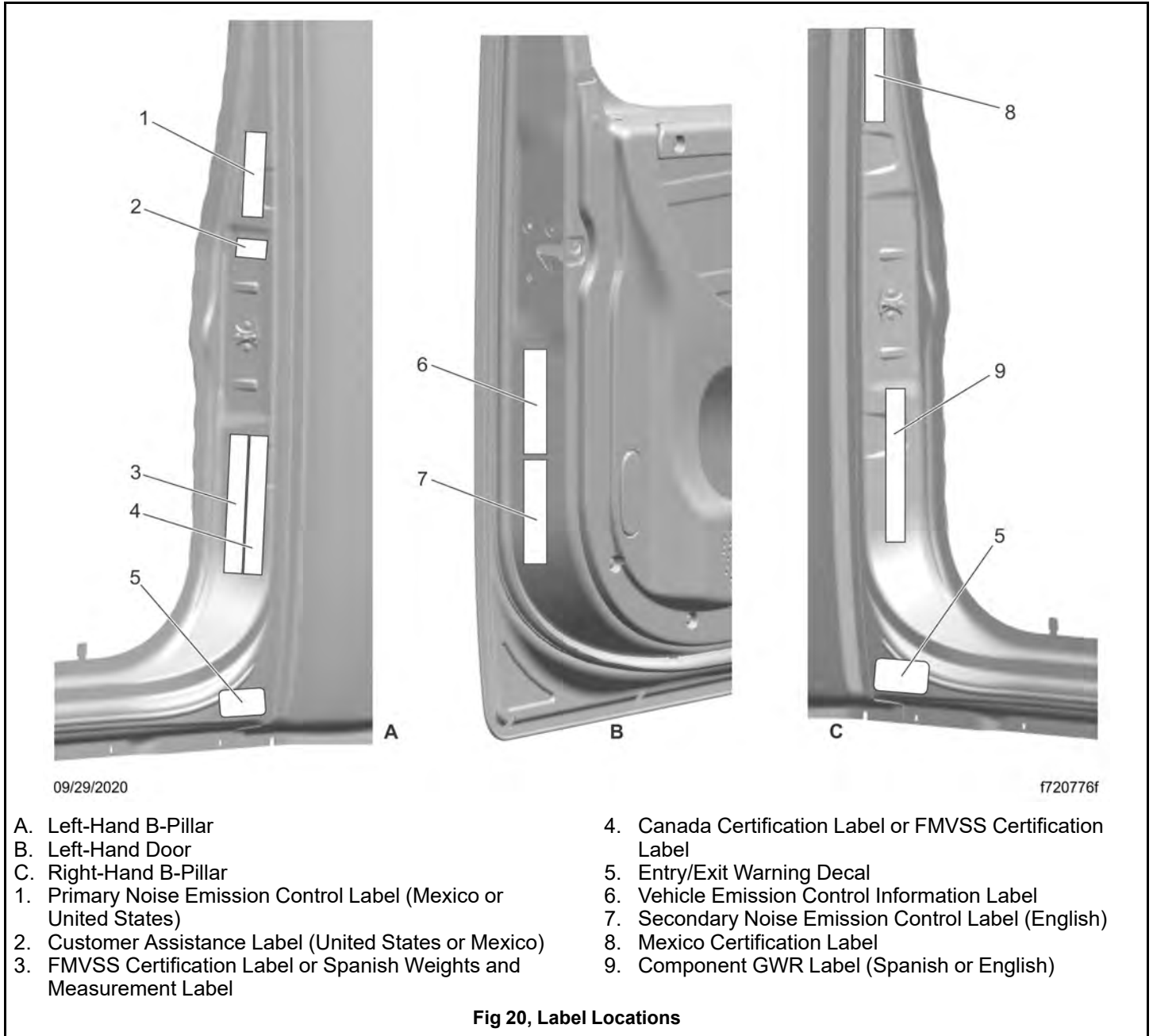

It is the owner's responsibility to maintain the vehicle so that it conforms to U.S. EPA and NHTSA regulations.

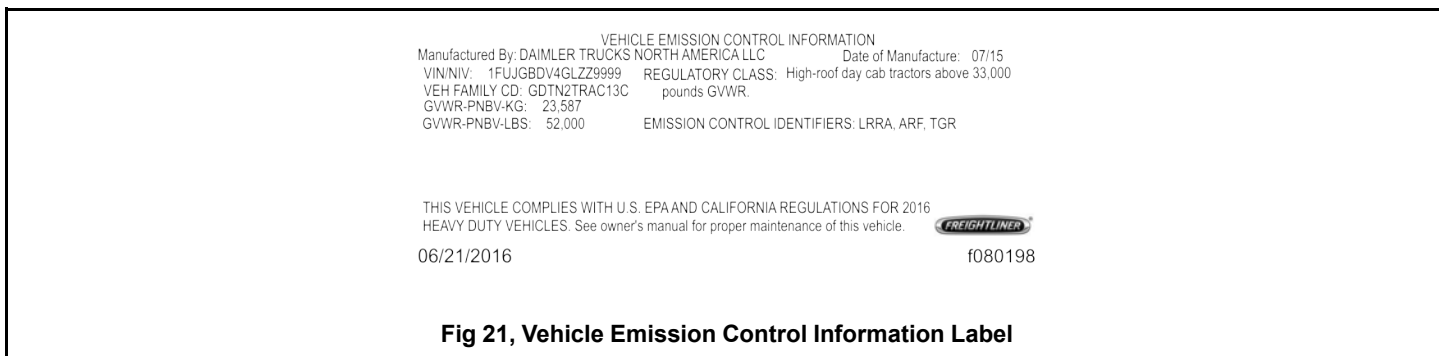

2.06.03 Noise Emission Control Labels

For vehicles manufactured for operation in the United States, an English-language Environmental Protection Agency (EPA) noise emission control label is applied to attest that the vehicle conforms to United States EPA regulations for noise. See Fig. 22, [EPA Vehicle Noise Emission Control Label \(complete vehicle\)](#).

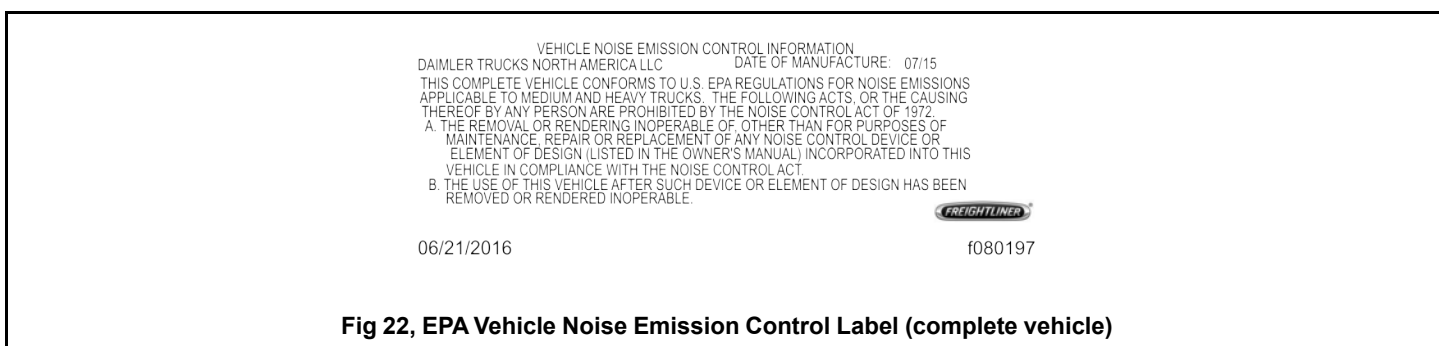

For vehicles manufactured for operation in Mexico, a Spanish-language Normas Oficiales Mexicanas (NOM) vehicle noise emission control label attesting that the vehicle conforms to Mexican NOM regulations for noise is applied. See Fig. 23, [NOM Vehicle Noise Emission Control Label \(complete vehicle\)](#).

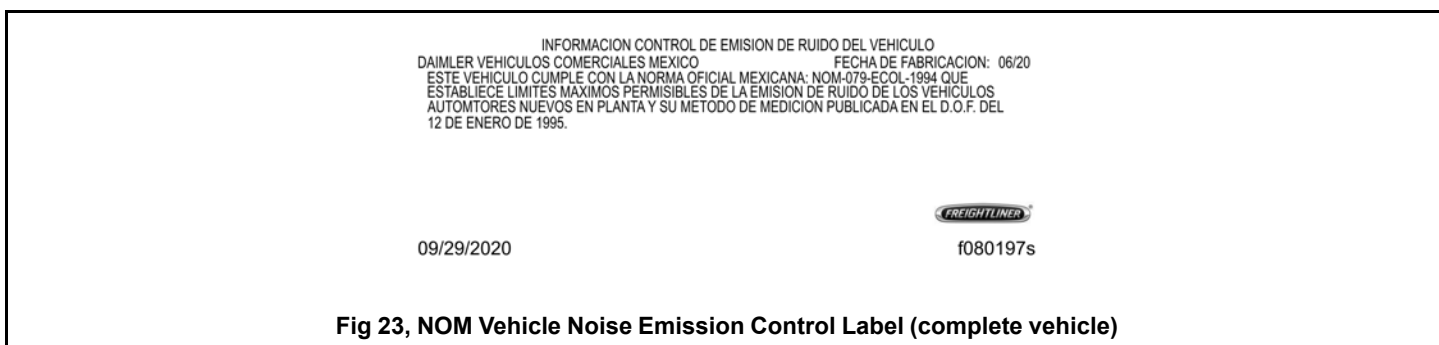

If only a single noise emission control label is applied, it will be located in the primary location on the left-hand B-pillar as shown in Fig. 24, [Label Locations](#).

For vehicles manufactured for dual Mexico/United States operation, both labels are applied. The NOM vehicle noise emission control label will be located in the primary location on the left-hand B-pillar and the EPA noise emission control label will be applied to the left-hand door as shown in Fig. 24, [Label Locations](#).

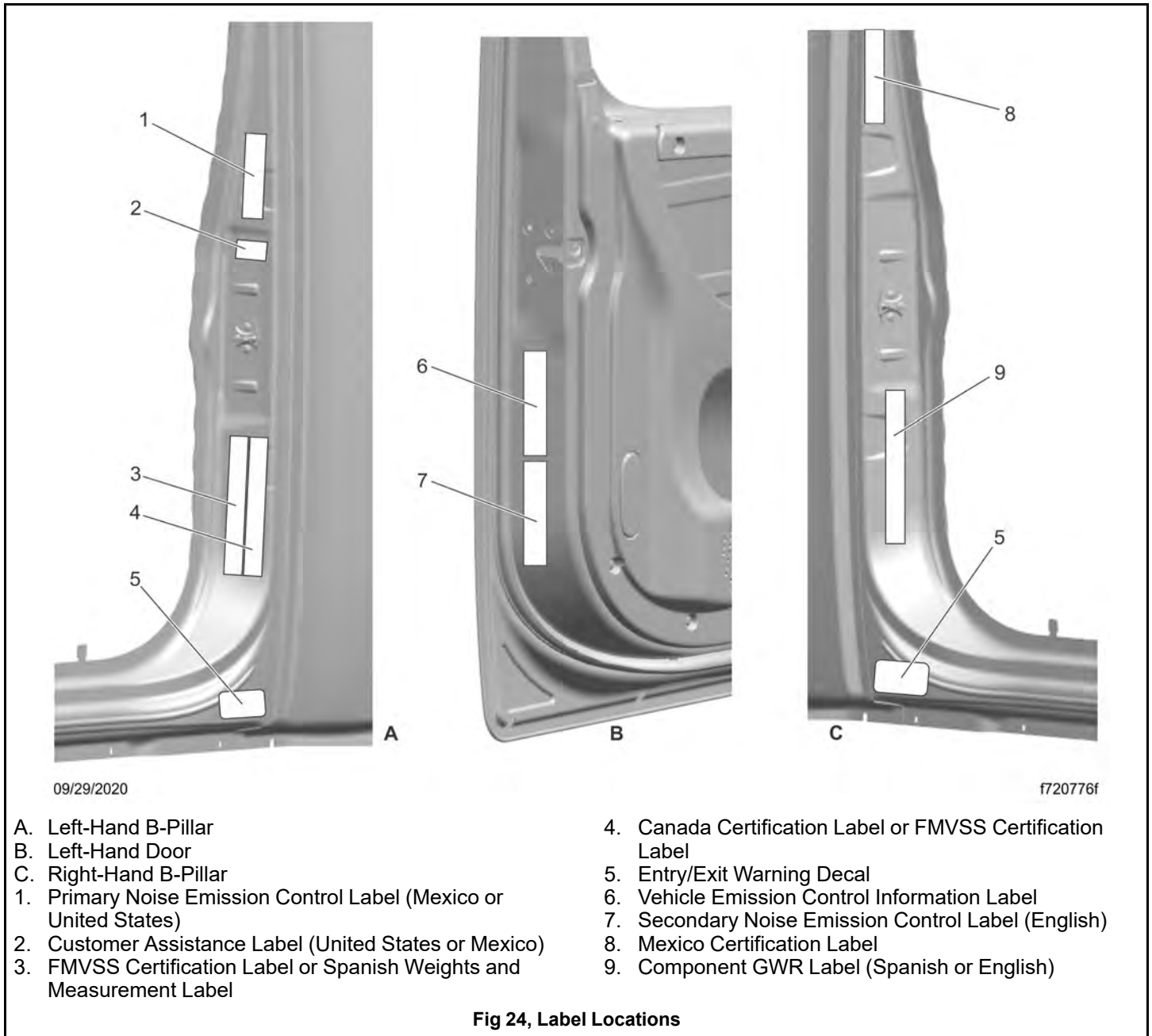

It is the owner's responsibility to maintain the vehicle so it conforms to all applicable regulations (EPA, NOM).

IMPORTANT: Certain Freightliner incomplete vehicles may be produced for the United States market with incomplete noise control hardware. Such vehicles will have an incomplete vehicle noise emission control information label. See Fig. 25, [EPA Vehicle Noise Emission Control Label \(incomplete vehicle\)](#). For such vehicles, it is the final-stage manufacturer's responsibility to complete the vehicle in conformity to the applicable regulations and label it for compliance.

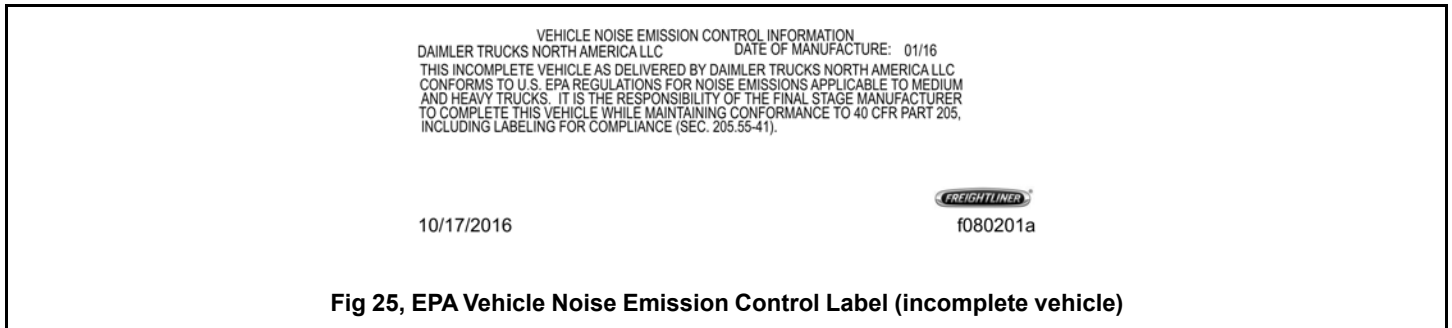

2.06.04 Certified Clean Idle Label

The California Air Resources Board (CARB) requires model year 2008 and newer heavy-duty diesel engines to meet CARB's Heavy-Duty Diesel Engine Idling Requirement in order to limit emissions of particulate matter and NOx.

Certified vehicles are equipped with a label placed near the bottom exterior edge of the left-hand door. See Fig. 26, [CARB Clean Idle Label](#).



2.07 Customer Assistance Label

The customer assistance center telephone number is printed on the customer assistance label. The label also includes a QR code encoded with the VIN, readable by dealer apps, to bring up information about the vehicle.

For vehicles domiciled in Mexico this label will be in Spanish as shown in Fig.27, [Customer Assistance Label, Spanish](#). For vehicles domiciled in the United States it will be printed in English as shown in Fig.28, [Customer Assistance Label, English](#).





The customer assistance label is located on the left-hand B-pillar, as shown in Fig.29,[Label Locations](#).

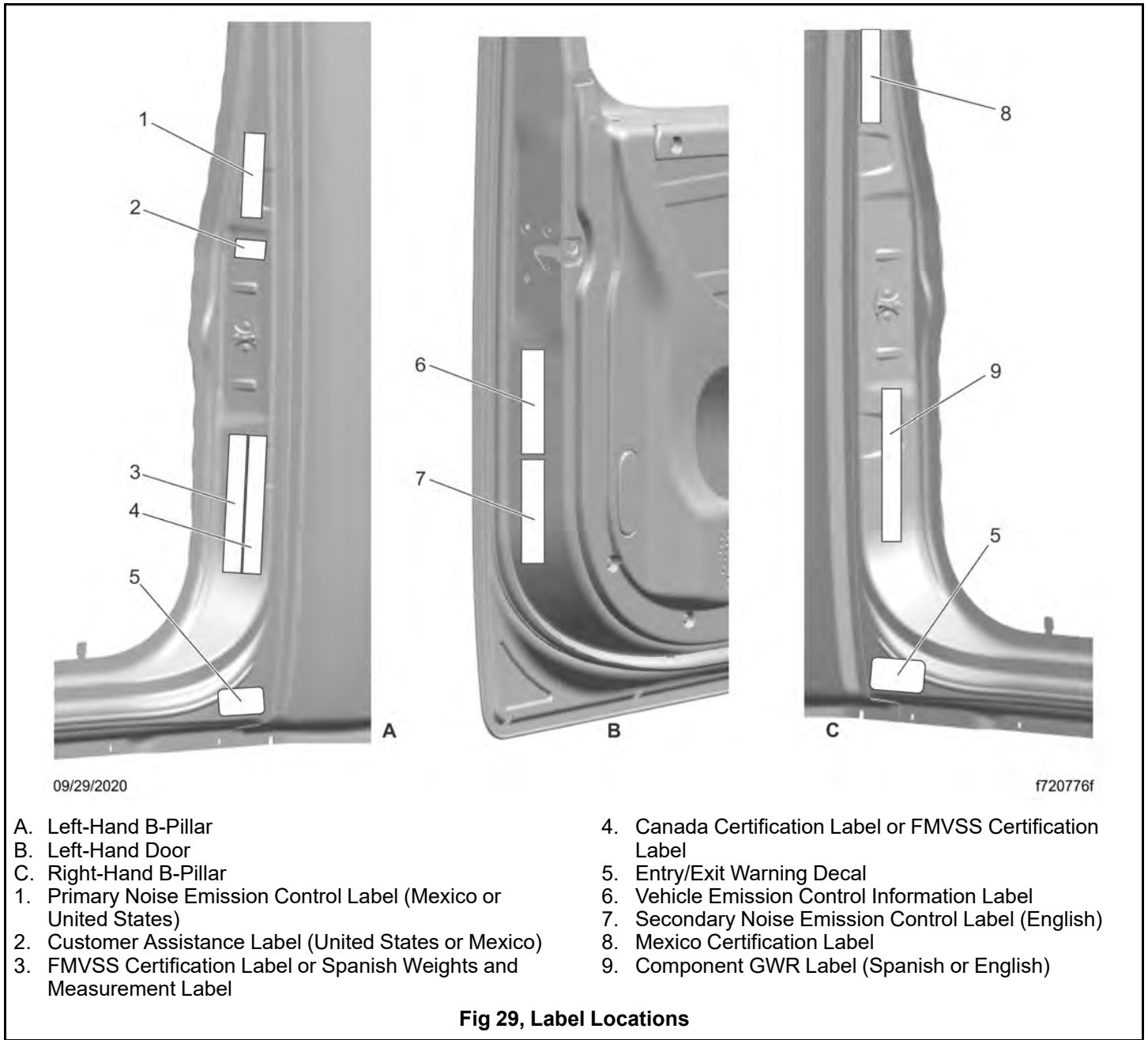

| | |
|--|----|
| 3.01 Door Locks and Handles..... | 30 |
| 3.02 Remote Keyless Entry | 31 |
| 3.02.01 Key Fob Use..... | 31 |
| 3.02.02 Replacement of the Key Fob Battery | 32 |
| 3.02.03 Key Fob Programming | 35 |
| 3.02.04 Specifications | 36 |
| 3.02.05 Grab Handles and Access Steps..... | 36 |
| 3.02.06 Cab-to-Sleeper Access | 40 |
| 3.02.07 Sleeper Door | 40 |
| 3.02.08 Sleeper Luggage Door | 42 |
| 3.02.09 Back-of-Cab Access..... | 44 |
| 3.02.10 External Cab Access | 46 |
| 3.02.11 Opening and Closing of the Hood | 46 |

3. Vehicle Access

3.01 Door Locks and Handles

One common key operates the ignition switch and all of the door locks.

IMPORTANT: Each key is numbered. Record the number so a duplicate key can be made, if needed.

To unlock the driver's door from outside the cab, insert the key in the lockset and turn it one-quarter turn clockwise. See Fig. 30, [Exterior Door Handle](#). To remove the key, turn it counterclockwise to the original position. Pull out on the door pull handle to open the door.

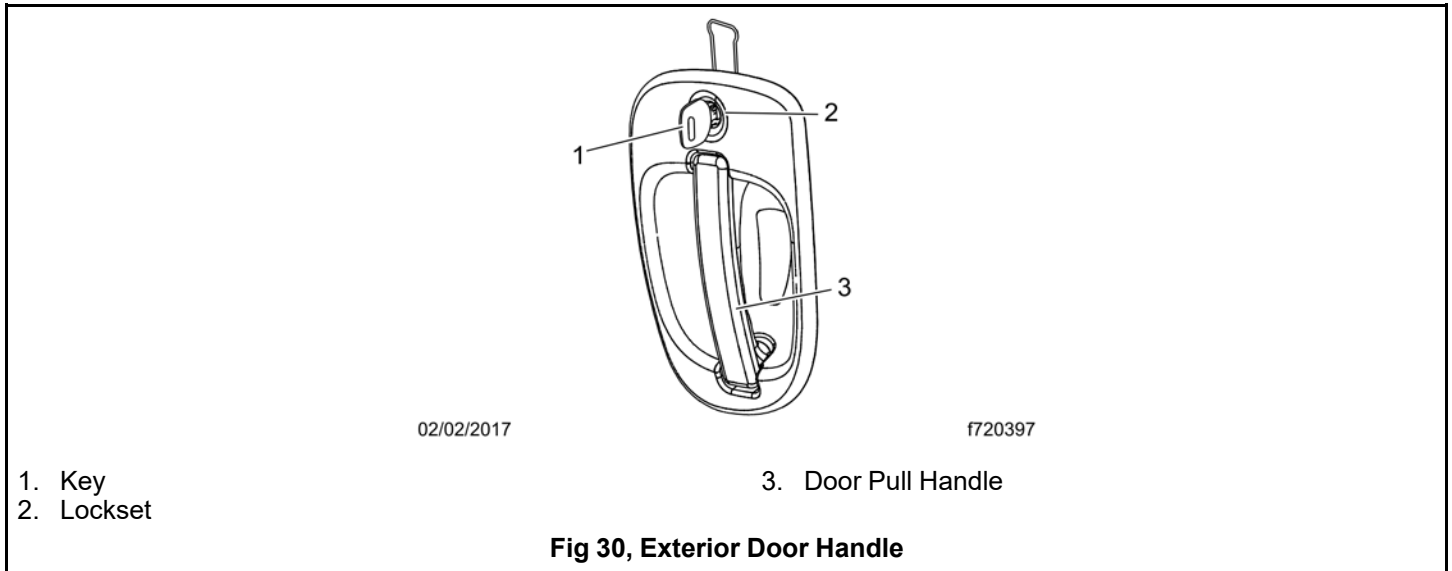

To unlock the passenger's door from outside the cab, insert the key in the lockset and turn it one-quarter turn counterclockwise. Turn the key clockwise to the original position to remove it.

NOTE: The cab door locks can be operated when the doors are open.

To lock a door from outside the cab, insert the key in the lockset and turn it in the direction opposite to the unlocking direction (counterclockwise for the driver's door, clockwise for the passenger's door). Close the door if it is open.

To lock either door from inside the cab, push the lock button downwards. See Fig.31, [Door Interior](#).

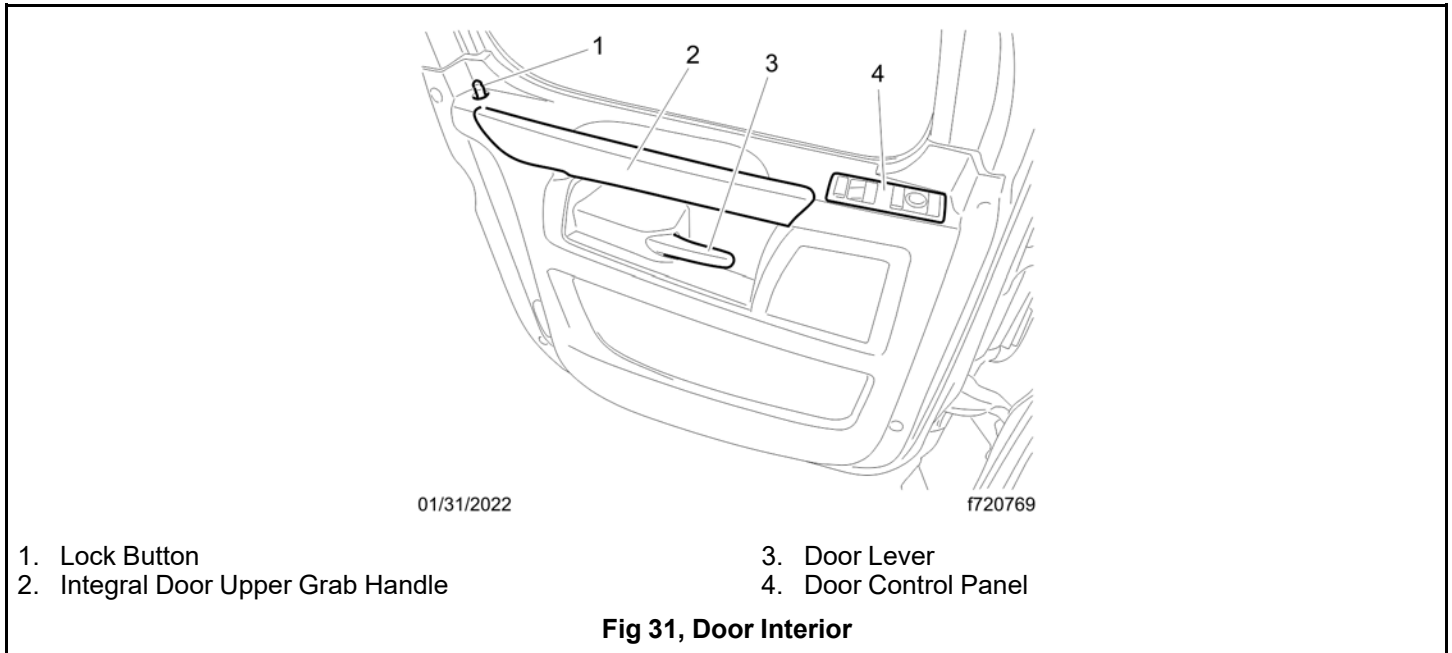

To open the door from the inside, lift up on the door lever. This will unlatch the door whether or not it is locked.

To unlock the door without unlatching it, pull the lock button upwards.

3.02 Remote Keyless Entry

3.02.01 Key Fob Use



WARNING:

Failure to observe the following safety instructions can result in an explosion, fire, damage to the key fob, electric shock and other injuries, as well as property damage:

- Do not pierce, break, crush, or cut the key fob or the battery.
- Do not expose the key fob or the battery to an open flame or extremely high temperatures.
- Do not expose the key fob or the battery to liquids or extremely low atmospheric pressure.



NOTICE:

Do not drop the key fob. Doing so could damage the fob, including damage to the battery compartment allowing the button cell battery to fall out.

Keyless entry is an available option for your vehicle. The key fob can be used to transmit a signal to remotely lock and unlock the doors, start and end the pre-trip light check, and open the door windows. See Fig.32, [Key Fob](#).

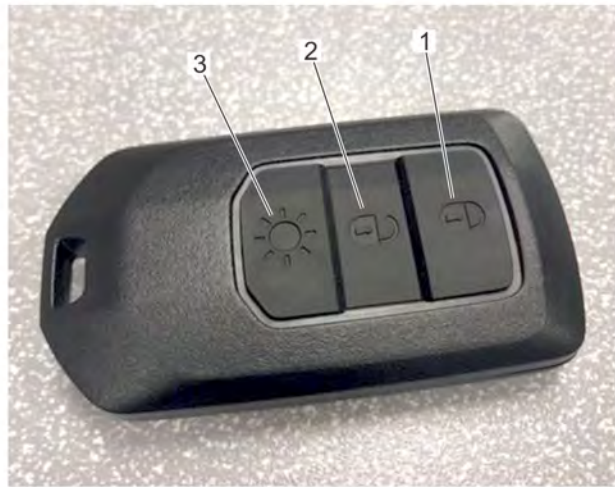

10/23/2019

f546880a

1. Lock Button
2. Unlock Button

3. Lamp Check Button

Fig 32, Key Fob

- To lock both doors, press the lock button.
- To unlock both doors, press the unlock button.
- To open the door windows, press the unlock button for three seconds.
- To start or end the pre-trip light check, press the lamp check button.

3.02.02 Replacement of the Key Fob Battery

**DANGER:**

Do not ingest the key fob battery. The button cell battery in this key fob is a chemical burn hazard. Always keep the key fob and button cell batteries away from children.

Always safely dispose of used batteries.

If the button cell battery in this key fob is swallowed, it can cause severe internal burns within two hours and can lead to death. If you think a battery might have been swallowed or otherwise placed inside any part of the body, seek immediate medical attention.

If the battery compartment does not close securely, stop using the key fob.

**WARNING:**

Failure to observe the following safety instructions can result in an explosion, fire, damage to the key fob, electric shock and other injuries, as well as property damage:

- Do not try to charge the key fob battery. It is not rechargeable.
- The key fob housing is made of plastic with sensitive electronic components and a CR2032 button cell battery. There is a risk of explosion if the battery is replaced with a battery other than a CR2032.
- The button cell battery that powers this device is considered hazardous and must be recycled or disposed of separately from household waste. Store the old battery in a safe place until it can be disposed of safely.

You will need a flat surface, a CR2032 replacement button battery, and a 5/32 inch (4mm) flat screwdriver or similar tool to replace the key fob battery.

1. Remove the key fob from the key ring.
2. Hold the fob with the opening for the key ring upwards and carefully insert the flat end of the screwdriver on one side of key fob as shown in Fig.33, [Opening the Key Fob](#). Twist the end of the screwdriver to pry the two halves apart.



07/12/2022

f547910a

Fig 33, Opening the Key Fob

3. Move the end of the screwdriver to the other side of the top of the fob and pry that side apart.
4. Use your fingers to separate the two pieces of the fob.
5. Lay the side of the fob with the battery flat on the table and insert the end of the screwdriver underneath the top of the battery to gently lift it out. See Fig.34, [Removing the Battery](#).

Dispose of the used battery safely according to local regulations.



Fig 34, Removing the Battery

6. Insert the new battery with the + side down and the blank side up as shown in Fig.35, [Inserting the Battery](#).

The bottom edge of the battery must be inserted toward the bottom of the key fob, pressing open the metal cradle to create space for it to slip into place.



Fig 35, Inserting the Battery

7. Align the hooked tag on the bottom edge of the circuit board side of the fob with the matching recess on the other side of the fob as shown in Fig.36, [Align the Key Fob Hook](#). Press the two sides of the fob together working from the bottom toward the top.

The two halves may need some adjustment to snap into place.

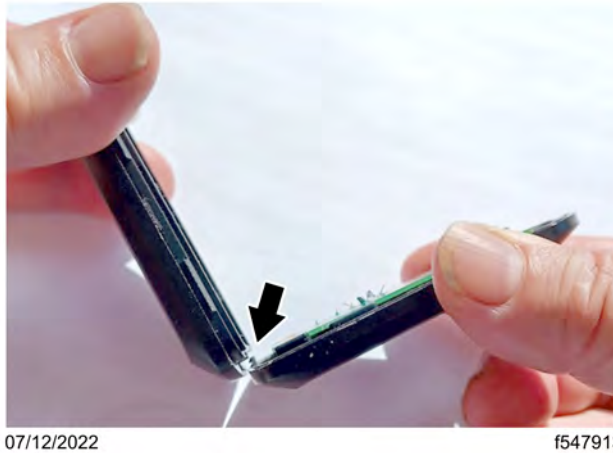

Fig 36, Align the Key Fob Hook

IMPORTANT: If the fob will not close completely and securely, open it and try again. If it is not possible to securely close the fob, stop using it. An unsecured button battery is hazardous. Safely dispose of the defective battery and fob according to local regulations and order a new fob at an authorised Freightliner dealership.

8. Verify the fob is fully and completely closed as shown in Fig.37, [Securely Closed Key Fob](#).



Fig 37, Securely Closed Key Fob

9. Attach the key fob to the key ring.

3.02.03 Key Fob Programming

A maximum of four fobs can be programmed to work on one vehicle. Whenever a new fob is needed, all existing fobs must be reprogrammed at the same time. Any existing fobs that were previously programmed will no longer work on the vehicle unless they are all reprogrammed at the same time.

To have the key fobs programmed, take the vehicle to an authorized Freightliner dealer or service facility.

3.02.04 Specifications

This system consists of a key fob that uses a radio frequency link for communication between the fob and the vehicle.

3.02.05 Grab Handles and Access Steps

Entering the Driver Side

For ease of entry and exit, there is a handle on both the A-pillar and the B-pillar. In addition, the steering wheel and door grab handle may be used to provide a secure handhold. There are at least two access steps to provide secure footholds.

**CAUTION:**

Slipping or falling from the vehicle can result in personal injury or property damage.

Wet or dirty shoes greatly increase the chance of slipping or falling. If your shoes are wet or dirty, be especially careful when entering or exiting the vehicle.

Always maintain three-point contact with the vehicle when entering or exiting the cab. Three-point contact means both feet and one hand, or both hands and one foot.

When steps are mounted on battery box covers, make sure that the cover is latched and secure before using the steps.

Do not step on the fuel tank, battery box, frame, etc. unless adequate slip resistant surfaces and handholds are provided.

Do not jump from the vehicle.

Do not use parts of the vehicle as hand holds that are not designed for this purpose.

1. Open the driver-side door and place anything that you are carrying in the cab.
2. Facing the cab, grasp the B-pillar and A-pillar grab handles with your hands. See Fig.38, [Driver-Side Cab Access](#).

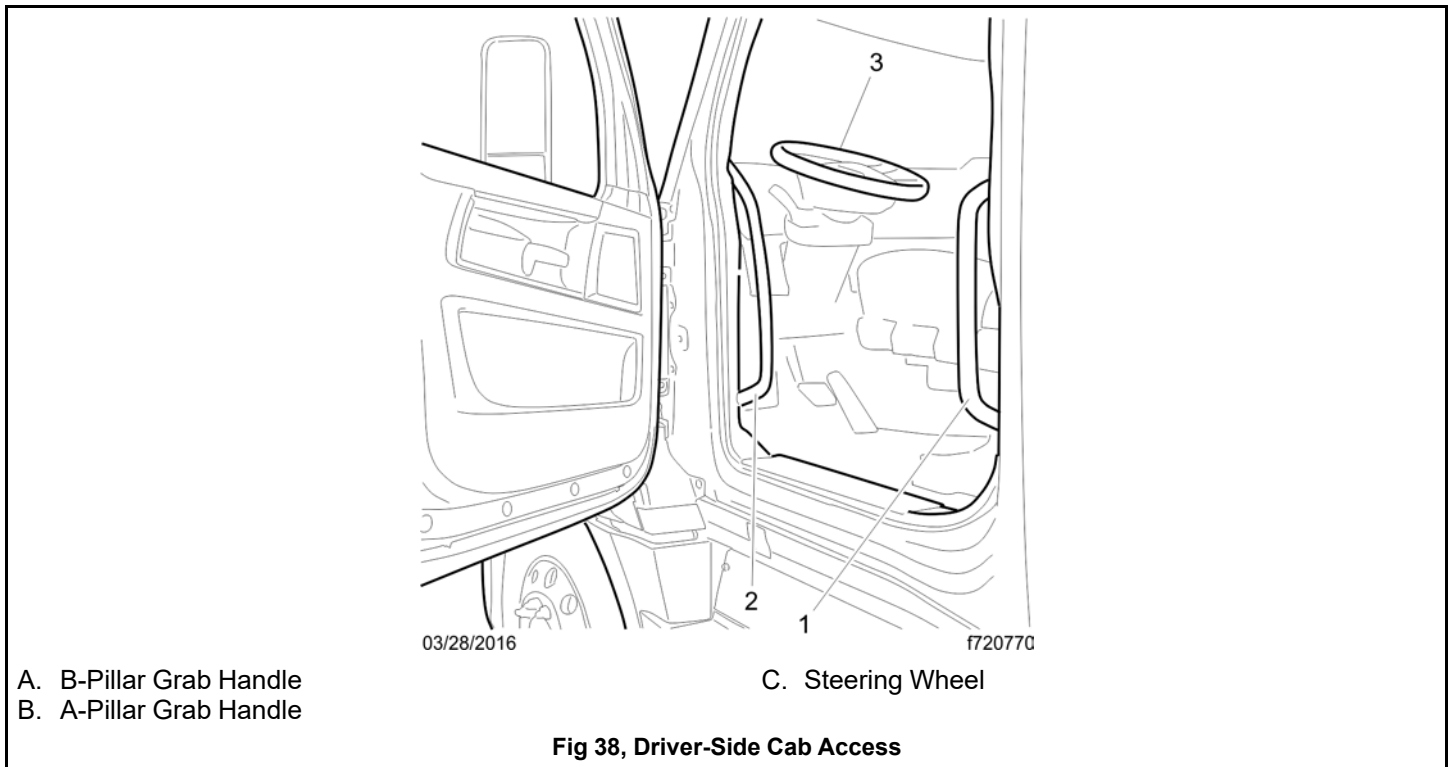

3. Step up on the bottom step with your right foot.
4. Step up on the top step with your left foot, grasping the grab handles higher as you move up.
5. Step into the cab with your right foot first, and grasp the steering wheel with your left hand.

Exiting the Driver Side

For ease of entry and exit, there is a handle on both the A-pillar and the B-pillar. In addition, the steering wheel and door grab handle may be used to provide a secure handhold. There are at least two access steps to provide secure footholds.

**CAUTION:**

Slipping or falling from the vehicle can result in personal injury or property damage.

Wet or dirty shoes greatly increase the chance of slipping or falling. If your shoes are wet or dirty, be especially careful when entering or exiting the vehicle.

Always maintain three-point contact with the vehicle when entering or exiting the cab. Three-point contact means both feet and one hand, or both hands and one foot.

When steps are mounted on battery box covers, make sure that the cover is latched and secure before using the steps.

Do not step on the fuel tank, battery box, frame, etc. unless adequate slip resistant surfaces and handholds are provided.

Do not jump from the vehicle.

Do not use parts of the vehicle as hand holds that are not designed for this purpose.

IMPORTANT: Do not attempt to exit the cab while carrying any items in your hands. Place them in an accessible location on the seat or cab floor and make sure they will not get in your way as you exit, then retrieve them after you have exited the cab.

**CAUTION:**

Always face in when exiting the cab. Do not attempt to exit with your back to the cab, as you would going down a flight of stairs. It is easier to slip or lose your balance. If you slip when exiting in this way, there is a greater likelihood of personal injury.

1. Grasp the steering wheel with your right hand and the A-pillar grab handle with your left hand, and place your left foot on the top step. See Fig.39, [Driver-Side Cab Access](#).

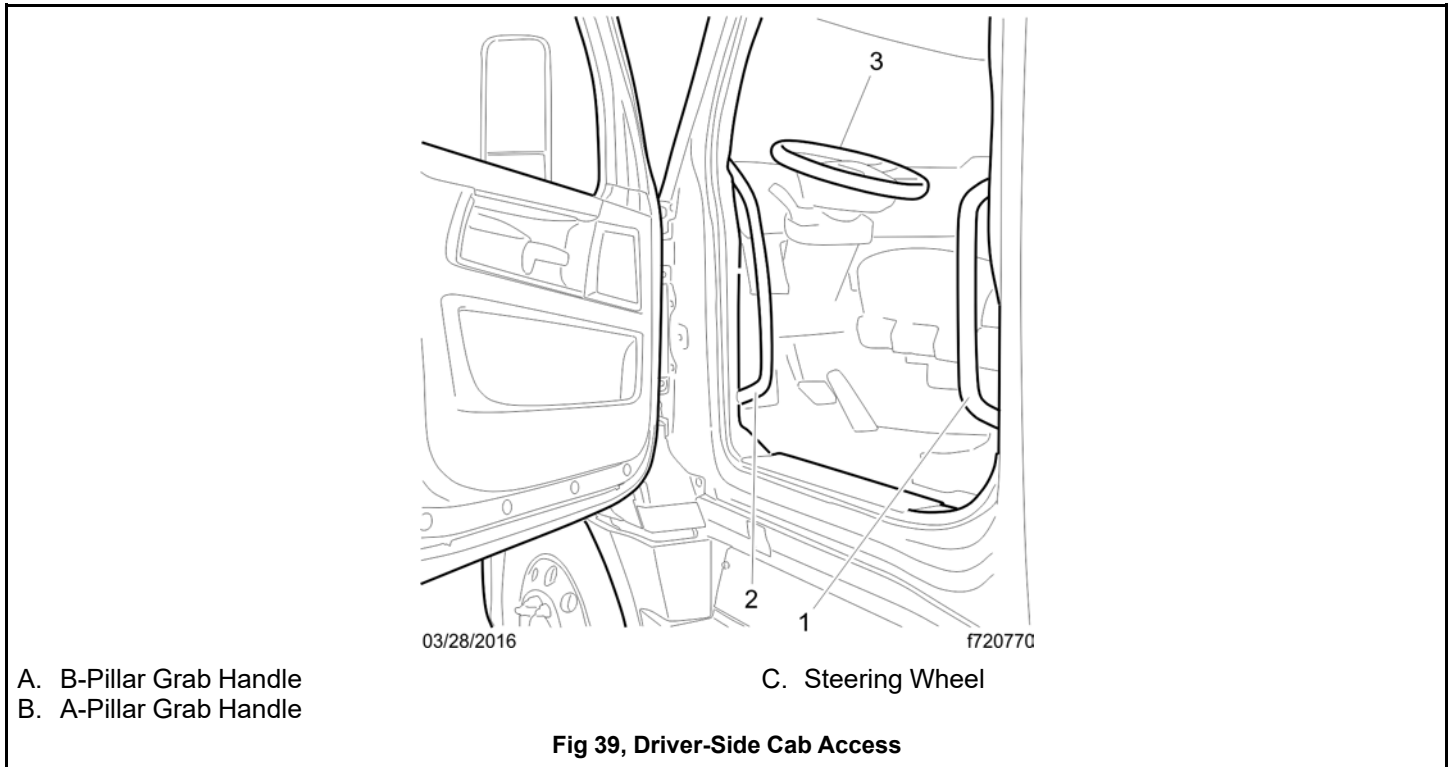

2. Face into the cab, and grasp the B-pillar grab handle with your right hand.
3. Step down on the bottom step with your right foot, grasping the grab handles lower as you move down.
4. Step to the ground with your left foot first.

Entering the Passenger Side

For ease of entry and exit, there is a handle on both the A-pillar and the B-pillar. In addition, the steering wheel and door grab handle may be used to provide a secure handhold. There are at least two access steps to provide secure footholds.



CAUTION:

Slipping or falling from the vehicle can result in personal injury or property damage.

Wet or dirty shoes greatly increase the chance of slipping or falling. If your shoes are wet or dirty, be especially careful when entering or exiting the vehicle.

Always maintain three-point contact with the vehicle when entering or exiting the cab. Three-point contact means both feet and one hand, or both hands and one foot.

When steps are mounted on battery box covers, make sure that the cover is latched and secure before using the steps.

Do not step on the fuel tank, battery box, frame, etc. unless adequate slip resistant surfaces and handholds are provided.

Do not jump from the vehicle.

Do not use parts of the vehicle as hand holds that are not designed for this purpose.

1. Open the passenger-side door and place anything that you are carrying in the cab.
2. Facing the cab, grasp the B-pillar and A-pillar grab handles with your hands. See Fig.40, [Passenger-Side Cab Access](#).

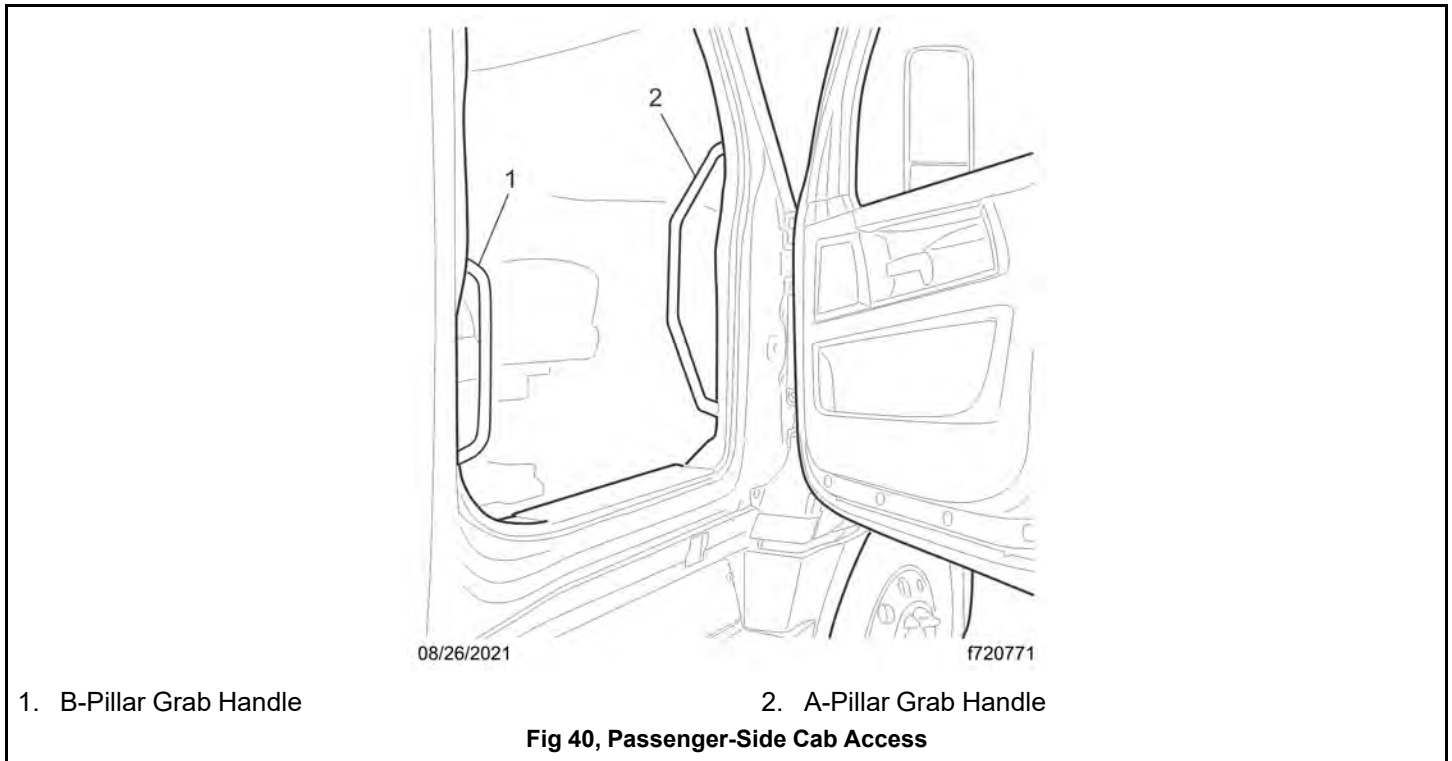

3. Step up on the bottom step with your left foot.
4. Step up on the top step with your right foot, grasping the grab handles higher as you move up.
5. Step into the cab with your left foot first, while holding on to the grab handle with your right hand.

Exiting the Passenger Side

For ease of entry and exit, there is a handle on both the A-pillar and the B-pillar. In addition, the steering wheel and door grab handle may be used to provide a secure handhold. There are at least two access steps to provide secure footholds.



CAUTION:

Slipping or falling from the vehicle can result in personal injury or property damage.

Wet or dirty shoes greatly increase the chance of slipping or falling. If your shoes are wet or dirty, be especially careful when entering or exiting the vehicle.

Always maintain three-point contact with the vehicle when entering or exiting the cab. Three-point contact means both feet and one hand, or both hands and one foot.

When steps are mounted on battery box covers, make sure that the cover is latched and secure before using the steps.

Do not step on the fuel tank, battery box, frame, etc. unless adequate slip resistant surfaces and handholds are provided.

Do not jump from the vehicle.

Do not use parts of the vehicle as hand holds that are not designed for this purpose.

IMPORTANT: Do not attempt to exit the cab while carrying any items in your hands. Place them in an accessible location on the seat or cab floor and make sure they will not get in your way as you exit, then retrieve them after you have exited the cab.

IMPORTANT: The sleeper doors have two-stage latching. When closing the doors, ensure that they are completely latched to prevent wind noise and water intrusion.

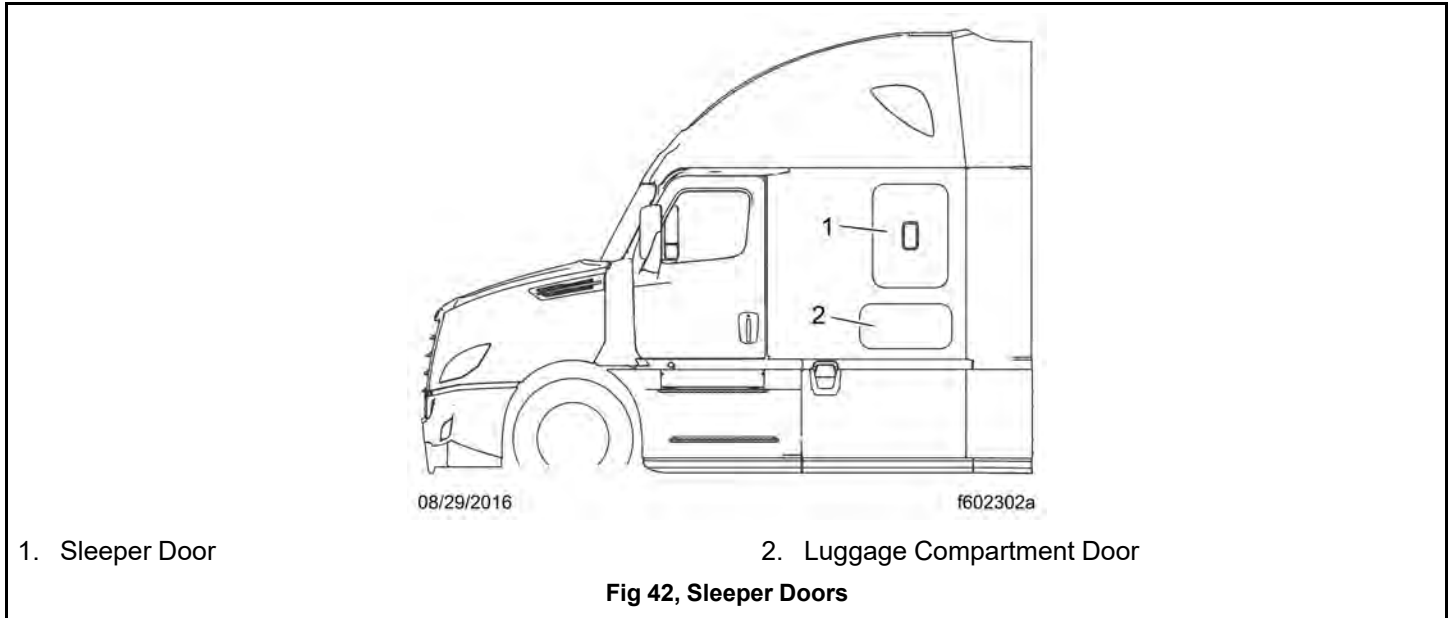

08/29/2016

f602302a

1. Sleeper Door

2. Luggage Compartment Door

Fig 42, Sleeper Doors

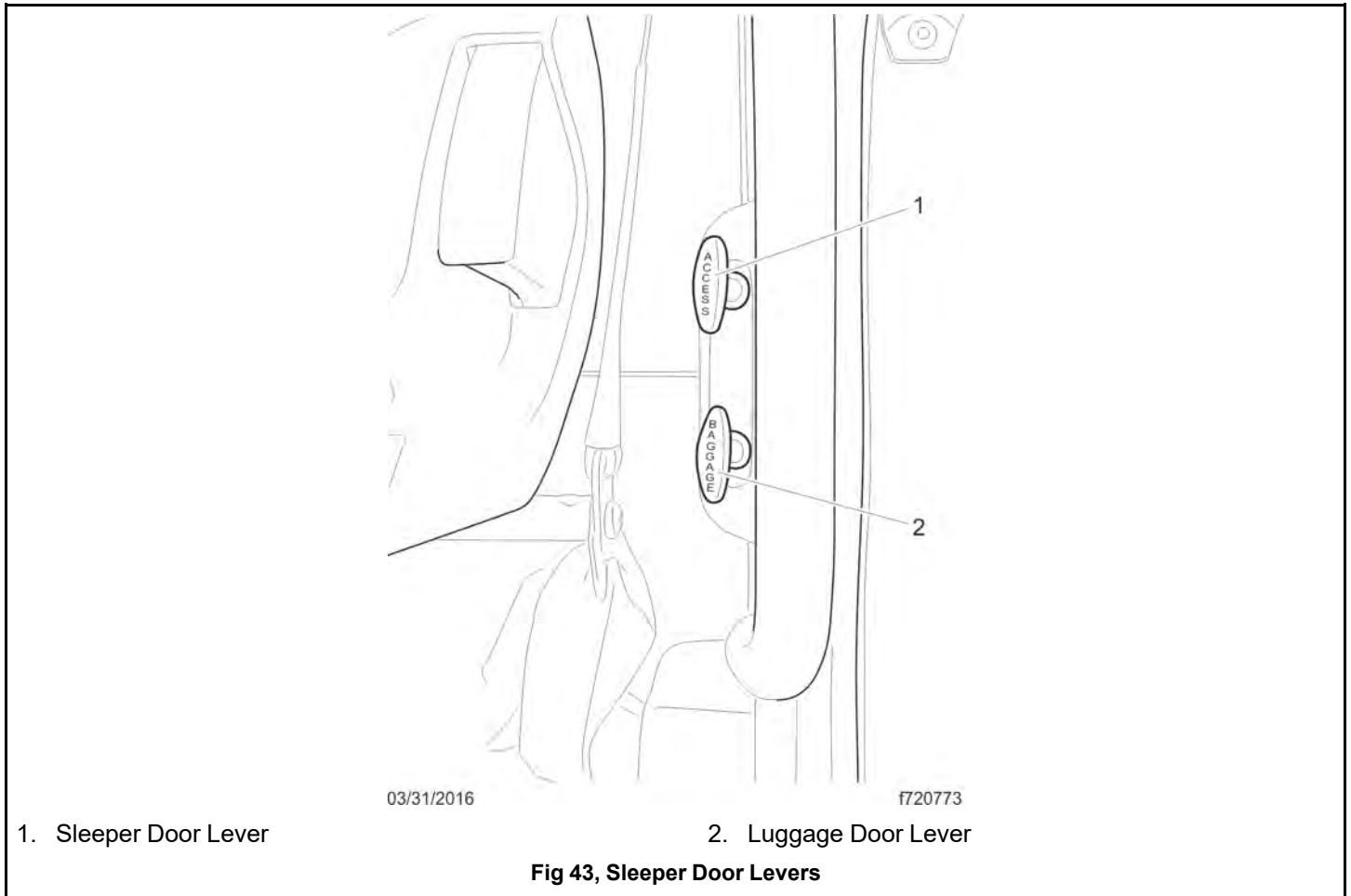

3.02.08 Sleeper Luggage Door

To open the sleeper luggage door (see Fig.44, [Sleeper Doors](#), Ref. 2), pull out on the lower lever located inside the cab door opening; see Fig.45, [Sleeper Door Levers](#). To close the sleeper luggage door, push it closed until it latches.

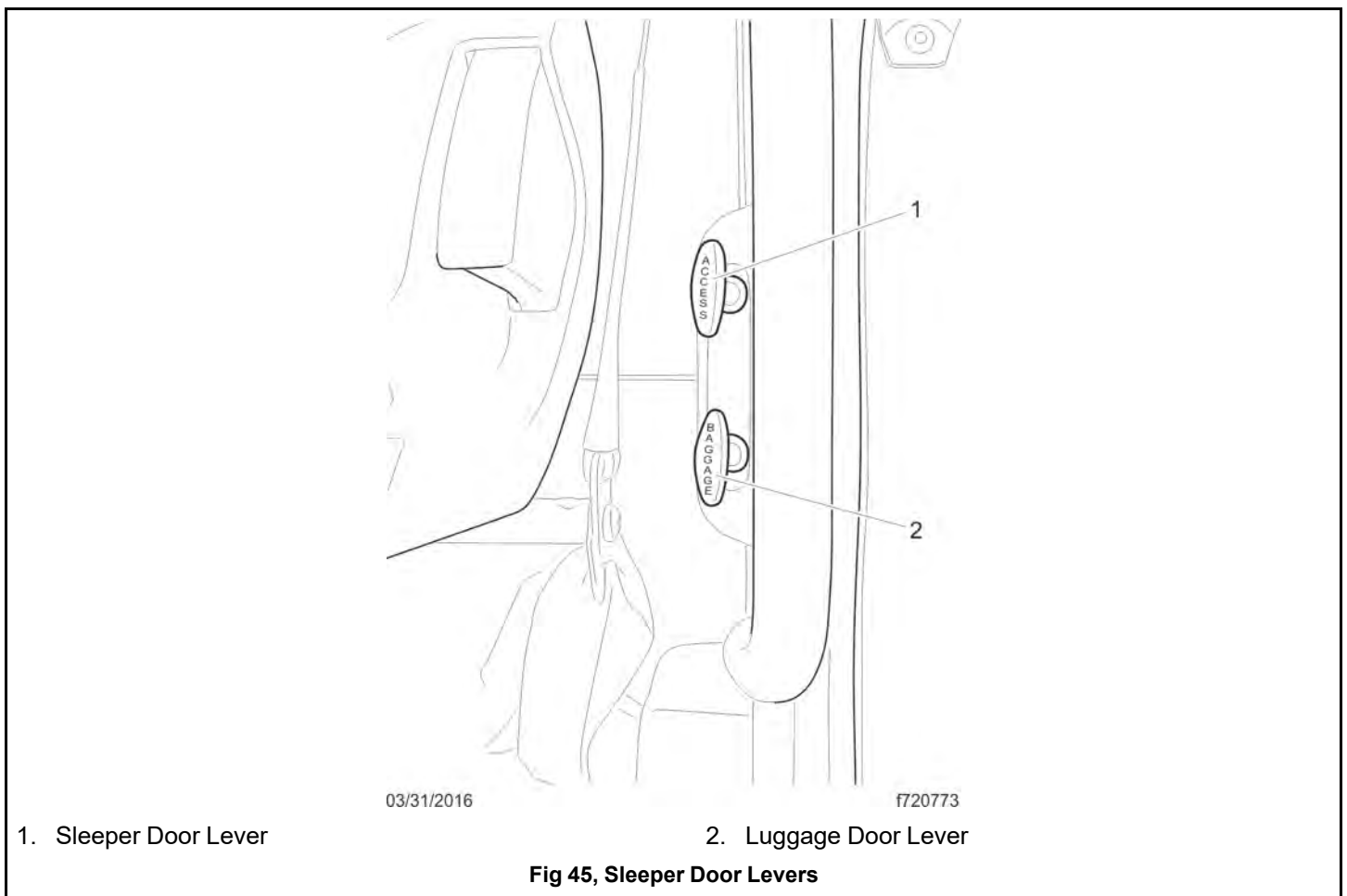
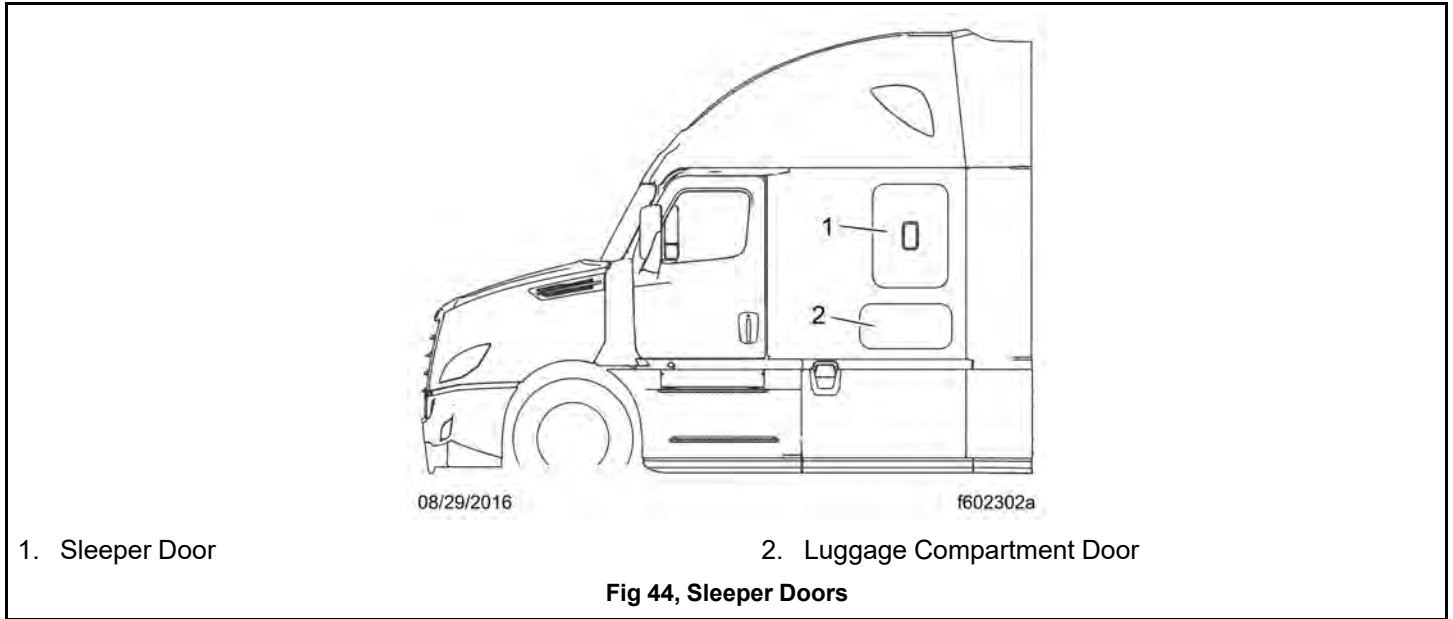

3.02.09 Back-of-Cab Access

Back-of-Cab Access, General Description

When trailer air and electrical connections cannot be reached conveniently from the ground, Federal Motor Carrier Safety Regulations require commercial carriers to provide back-of-cab access.

A grab handle is typically located on the back wall of the sleeper or cab. Steps are mounted on the frame rail, and a deck plate is mounted across the top of the frame rails. See Fig.46, [Back-of-Cab Access](#).

**CAUTION:**

Follow these rules for back-of-cab access. Failing to follow these rules could lead to a fall, and possible personal injury.

Never step on any exterior part unless it has a slip-resistant surface meant for safe stepping. If the surface is movable, such as a battery box cover with a slip-resistant surface, be certain it is firmly secured.

Be careful not to trip on items such as chains or air lines in the back-of-cab area.

Always follow safety procedures for back-of-cab access, maintaining three-point contact both hands and one foot, or both feet and one hand whenever moving around, and always face in toward the deck plate when climbing up or down.

Wet or dirty shoes, steps, or grab rails greatly increase the chance of slipping or falling. If your shoes or the contact areas are wet or dirty, clean and dry them as much as possible before accessing the back of cab area, and be especially careful when climbing or standing on the vehicle.

Never jump onto, or off of, a vehicle; doing so creates a very high likelihood of a fall and personal injury.

IMPORTANT: Climb onto, and down from, back-of-cab access facing in toward the vehicle, as you would on a ladder. Do not climb up or down facing out away from the vehicle.

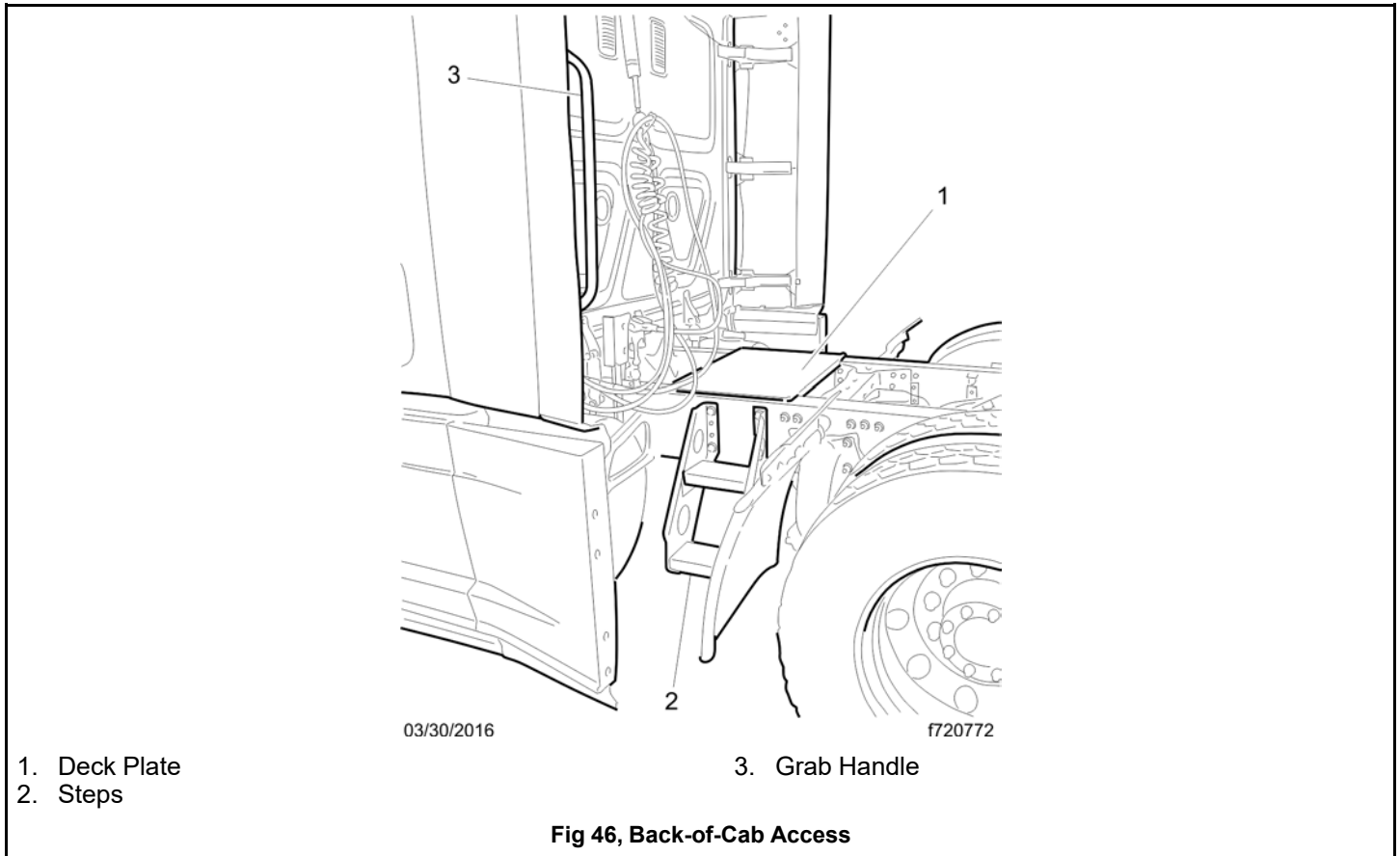

Accessing Back-of-Cab Area



WARNING:

External surfaces of the exhaust system remain hot after the engine has been shut down. When accessing the back of the cab or sleeper, do not touch any part of the exhaust system other than the exhaust-mounted grab handle, if equipped, or severe burns could occur.

1. Facing the deckplate, grasp the grab handle with both hands. Reach up as far as is comfortable.
2. Place one foot on the bottom step and pull yourself up.
3. Place your other foot on the top step.
4. Move your lower hand to a higher position on the grab handle.
5. Step onto the deck plate.

Exiting Back-of-Cab Area

1. Facing toward the center of the vehicle, grasp the grab handle with both hands.
2. Step one foot at a time onto the top step.
3. Move your upper hand to a lower position on the grab handle.
4. Move one foot to the bottom step.

- Step to the ground with your upper foot first.

3.02.10 External Cab Access

A-Pillar Turning Vane



WARNING:

When accessing the outside of the cab to clean the door's windows or windshield, do not grab or hold onto the A-pillar turning vane. This feature is not designed as a steadying device or handhold.

Misuse of the turning vane may result in injury to the operator or damage to the truck.

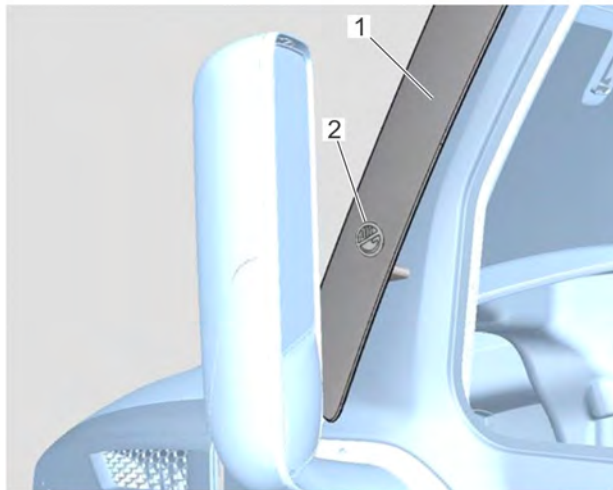

09/13/2021

f720829

1. A-Pillar Turning Vane

2. "Not a Handhold" Symbol

Fig 47, A-Pillar Turning Vane

3.02.11 Opening and Closing of the Hood

Opening and Closing the Hood, General Description

The hood can be raised to a full-open position. Tilt-assist struts help to both raise the hood and lower it into the vehicle operating position.

In the vehicle operating position, the hood is secured to the cab-mounted cowl by a hold-down latch on each side.

Newer vehicles may be equipped with a right-hand locking hood strut. This strut locks automatically when the hood is fully opened. See Fig. 48, [Locking Right-Hand Hood Strut](#).

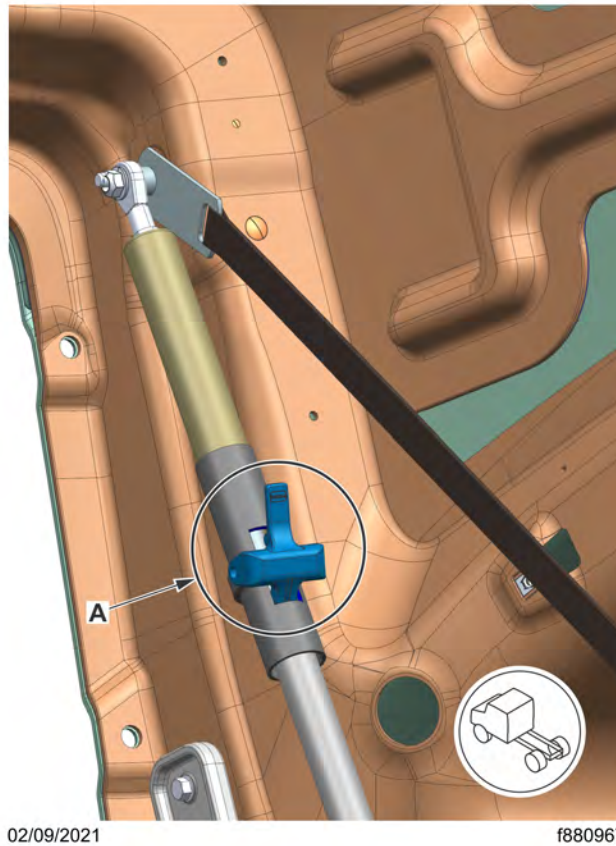

02/09/2021

f880967

A. Locking Lever

Fig 48, Locking Right-Hand Hood Strut

To unlock the strut and lower the hood, flip the lever located midway on the strut downwards.

Opening the Hood

1. Release both hood hold-down latches by pulling the handles outward.
2. Slowly tilt the hood with both hands on the grab handle.
3. As the hood starts to open, walk backwards as you pull. The hood will stop in the full-open position.

IMPORTANT: If equipped, check that the automatic locking hood strut is fully engaged before working on the vehicle.

Closing the Hood

1. If the vehicle is equipped with a locking hood-strut, disengage it by pushing the lever down.
2. Push on the top center of the hood, tilting it toward the closed position.
3. As the hood goes over center, allow it to settle on the rear supports.
4. Make sure the hood is flush with the cowl, then secure the hood by engaging both hood hold-down latches.

IMPORTANT: Make sure that both hood hold-down latches are fully engaged before operating the vehicle.

| | |
|--|----|
| 4.01 Instrumentation Control Unit: ICUC..... | 53 |
| 4.01.01 General Description | 53 |
| 4.01.02 Ignition Sequence | 53 |
| 4.01.03 ICUC Screen Navigation | 54 |
| 4.01.04 Time and Date | 58 |
| 4.01.05 Software Updates | 58 |
| 4.02 Driver Display Overview: ICUC..... | 61 |
| 4.02.01 ICUC Alert Messages..... | 61 |
| 4.02.02 ICUC Time and Alarm Settings..... | 62 |
| 4.02.03 ICUC Driver Display Screens | 63 |
| 4.03 Digital Gauges and System Monitors: ICUC | 74 |
| 4.03.01 ICUC Gauges | 74 |
| 4.03.02 Engine Oil Temperature Gauge | 75 |
| 4.03.03 Turbocharger Boost Pressure Gauge | 76 |
| 4.03.04 Transmission Oil Temperature Gauge..... | 77 |
| 4.03.05 Drive Axle Oil Temperature Gauges..... | 79 |
| 4.03.06 Application Air Pressure Gauge | 80 |
| 4.03.07 DEF and Diesel Particulate Filter Monitoring | 81 |
| 4.03.08 Eco Driver Feedback..... | 82 |
| 4.03.09 Tire Pressure Monitoring System | 82 |
| 4.03.10 Other ICUC Gauges and Measurements..... | 83 |
| 4.03.11 Alerts | 83 |
| 4.03.12 Battery Voltage | 83 |
| 4.03.13 Diagnostics | 84 |
| 4.03.14 Engine Maintenance | 84 |
| 4.03.15 Maintenance System..... | 84 |
| 4.03.16 Transmission Prognostics..... | 85 |
| 4.03.17 Suspension Air Pressure | 85 |
| 4.03.18 ICUC Vehicle Operations: Vehicle Settings | 86 |
| 4.03.19 Cruise Control | 86 |
| 4.03.20 Transmission | 86 |

| | |
|---|-----|
| 4.03.21 Attention Assist..... | 87 |
| 4.03.22 Engine Idle Adjustment..... | 87 |
| 4.03.23 Optimized Idle | 87 |
| 4.04 Infotainment: ICUC..... | 88 |
| 4.04.01 Safety Information..... | 88 |
| 4.04.02 Navigation and Infotainment Reception | 88 |
| 4.04.03 General ICUC Infotainment Information | 88 |
| 4.04.04 ICUC Audio Features | 90 |
| 4.04.05 ICUC Telephone Features | 91 |
| 4.05 Analog Instruments | 92 |
| 4.05.01 Air Intake Restriction Gauge | 92 |
| 4.05.02 Application Air Pressure Gauge | 93 |
| 4.05.03 Coolant Temperature Gauge..... | 93 |
| 4.05.04 Drive Axle Oil Temperature Gauges..... | 94 |
| 4.05.05 Engine Oil Pressure Gauge | 95 |
| 4.05.06 Engine Oil Temperature Gauge..... | 96 |
| 4.05.07 Fuel/Diesel Exhaust Fluid (DEF) Gauge | 97 |
| 4.05.08 Primary and Secondary Air Pressure Gauges | 98 |
| 4.05.09 Speedometer..... | 99 |
| 4.05.10 Suspension Air Pressure Gauge | 100 |
| 4.05.11 Tachometer | 100 |
| 4.05.12 Transmission Fluid Temperature Gauge | 101 |
| 4.05.13 Turbocharger Boost Pressure Gauge | 102 |
| 4.05.14 Voltmeter..... | 102 |
| 4.06 Instrumentation Control Unit: ICC5 | 103 |
| 4.06.01 General Description, ICC5..... | 103 |
| 4.06.02 Ignition Sequence | 103 |
| 4.06.03 ICC5 Screen Navigation | 104 |
| 4.06.04 ICC5 Steering Wheel Buttons | 105 |
| 4.06.05 ICC5 Touch Screen Operation | 106 |
| 4.06.06 Time and Date | 107 |

| | |
|---|-----|
| 4.06.07 Software Updates | 107 |
| 4.07 Driver Display Overview: ICC5 | 107 |
| 4.07.01 General Description, ICC5 Display | 107 |
| 4.07.02 ICC5 Driver Display Screen | 109 |
| 4.07.03 ICC5 Steering Wheel Buttons | 109 |
| 4.07.04 Basic ICC5 Functions | 111 |
| 4.08 Digital Gauges and System Monitors: ICC5 | 112 |
| 4.08.01 ICC5 Gauges | 112 |
| 4.08.02 Coolant Temperature Gauge | 114 |
| 4.08.03 Engine Oil Pressure Gauge | 115 |
| 4.08.04 Engine Oil Temperature Gauge | 116 |
| 4.08.05 Transmission Oil Temperature Gauge | 116 |
| 4.08.06 Drive Axle Oil Temperature Gauges | 116 |
| 4.08.07 Lift Axle Pressure Gauge | 116 |
| 4.08.08 DPF Soot Level Gauge | 117 |
| 4.08.09 Application Air Pressure Gauge | 117 |
| 4.08.10 Suspension Air Pressure Gauge | 117 |
| 4.08.11 Trailer Application Air Pressure Gauge | 117 |
| 4.08.12 Turbo Boost Pressure Gauge | 117 |
| 4.08.13 Base ICC5 A-Panel Gauges | 117 |
| 4.08.14 Battery Voltage | 117 |
| 4.08.15 Speedometer and Tachometer | 118 |
| 4.08.16 Fuel Level Gauge | 119 |
| 4.08.17 Diesel Exhaust Fluid (DEF) Level Gauge | 119 |
| 4.08.18 Odometer | 119 |
| 4.08.19 Primary and Secondary Air Gauges | 120 |
| 4.08.20 Floating ICC5 A-Panel Gauges | 121 |
| 4.08.21 Eco Driver Feedback | 122 |
| 4.08.22 ICC5 B-Panel Chassis Status Information | 123 |
| 4.08.23 Tire Pressure Monitoring System (TPMS) | 123 |
| 4.08.24 Axles | 124 |

| | |
|--|-----|
| 4.08.25 Maintenance System..... | 124 |
| 4.08.26 Diagnostics | 125 |
| 4.08.27 Active Driver Alerts | 125 |
| 4.08.28 ICC5 B-Panel Controls | 125 |
| 4.08.29 Digital Switches | 126 |
| 4.08.30 Optimized Idle | 126 |
| 4.08.31 Settings..... | 127 |
| 4.08.32 Lighting | 128 |
| 4.08.33 Climate Control Information | 129 |
| 4.09 Infotainment: ICC5 | 130 |
| 4.09.01 General ICC5 Infotainment Information..... | 130 |
| 4.09.02 System Settings..... | 130 |
| 4.09.03 Connecting and Disconnecting a Phone Using Bluetooth®..... | 131 |
| 4.09.04 Using a Mobile Phone | 133 |
| 4.09.05 Phone Contacts and Call List..... | 136 |
| 4.09.06 Radio | 138 |
| 4.09.07 Sound System Settings | 140 |
| 4.09.08 Favorites | 140 |
| 4.09.09 Media..... | 141 |
| 4.09.10 Smartphone | 141 |
| 4.10 Warnings, Indicators, and Messages | 142 |
| 4.10.01 Audible Alerts: ICUC | 142 |
| 4.10.02 Audible Alerts: ICC5..... | 142 |
| 4.10.03 Warnings, Indicators, and Messages | 142 |
| 4.10.04 Engine Protection System | 157 |

4. Instruments

4.01 Instrumentation Control Unit: ICUC

4.01.01 General Description

The instrumentation control unit (ICU) provides the driver with engine and vehicle information. A New Cascadia vehicle can be equipped with either an ICUC or ICC5. See Fig.49, [Instrument Cluster Overview - ICUC](#) for a typical ICUC layout.

This section provides general system and operating instructions for ICUC components. Following sections provide more detailed information.

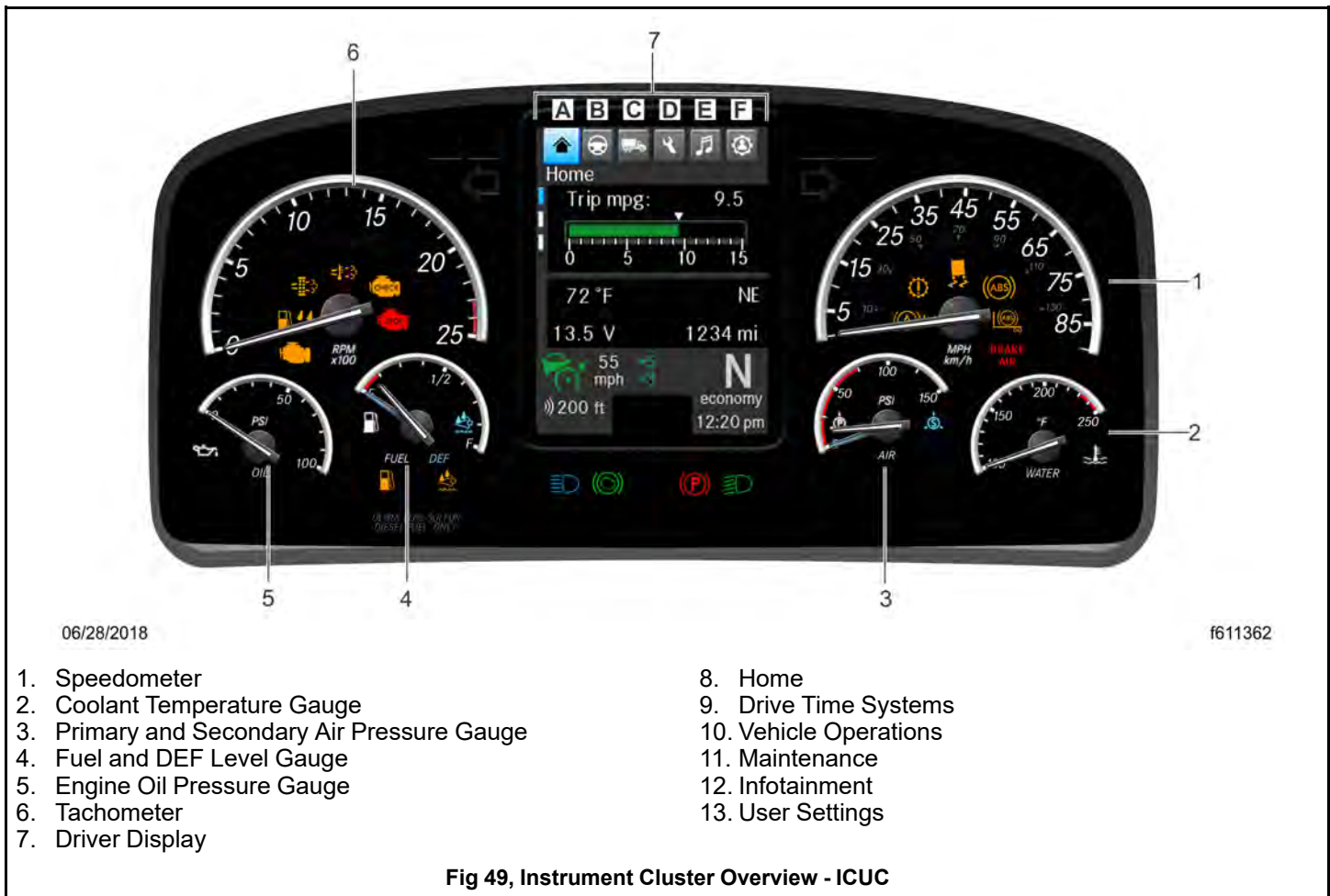

ICUC

The instrument cluster unit (common), or ICUC, is comprised of six physical gauges, indicator lamps (telltales), a six inch portrait driver display screen, steering wheel mounted switches, and audible warning systems. Warning and indicator lamps illuminate in red (warning), amber (caution), green (status on), or blue (high-beam headlights active).

The driver display screen provides information on various vehicle systems as well as warnings, cautions, and notifications on systems status.

4.01.02 Ignition Sequence

When the ignition is turned on, the ICU runs a self-check. Observing the ignition sequence is a good way to ensure the ICU is functioning properly.

IMPORTANT: Do not crank the engine until the ICU self-check is complete.

ICUC

NOTE: Air gauges in the ICUC do not complete a sweep of their dials during the ignition sequence.

When the ignition is turned on, the following actions should occur in the ICUC:

- Freightliner and engine logo displays on the driver display until startup is complete
- Speedometer and tachometer complete a full sweep of their dials
- Warning and indicator lamps illuminate, then are extinguished (if not active)
- Audible alert sounds for any active faults
- Active alerts are displayed on the ICUC screen.

If the ICUC receives active fault codes, it displays them one after the other until the ignition is turned off. The alerts are displayed until they are acknowledged. If there are no active faults, the ICUC displays the home screen after the self-check completes.

IMPORTANT: If any red or amber warning and indicator lamps do not illuminate during the ICUC self-check or do not go out (if not active) after the self-check completes, take the vehicle to an authorized Freightliner service facility as soon as possible. If active faults are present, take the action outlined in "Warnings, Indicators, and Messages" tables in this chapter, then take the vehicle to an authorized Freightliner service facility as soon as possible.

4.01.03 ICUC Screen Navigation

In the ICUC, the driver display screen is broken up into three areas: a navigable menu at the top of the screen, the display area (with a screen indicator if there is more than one page), and a static display at the bottom of the screen. See Fig. 50, [ICUC Driver Display](#).

NOTE: To adjust the brightness of ICUC screen go to User Settings.

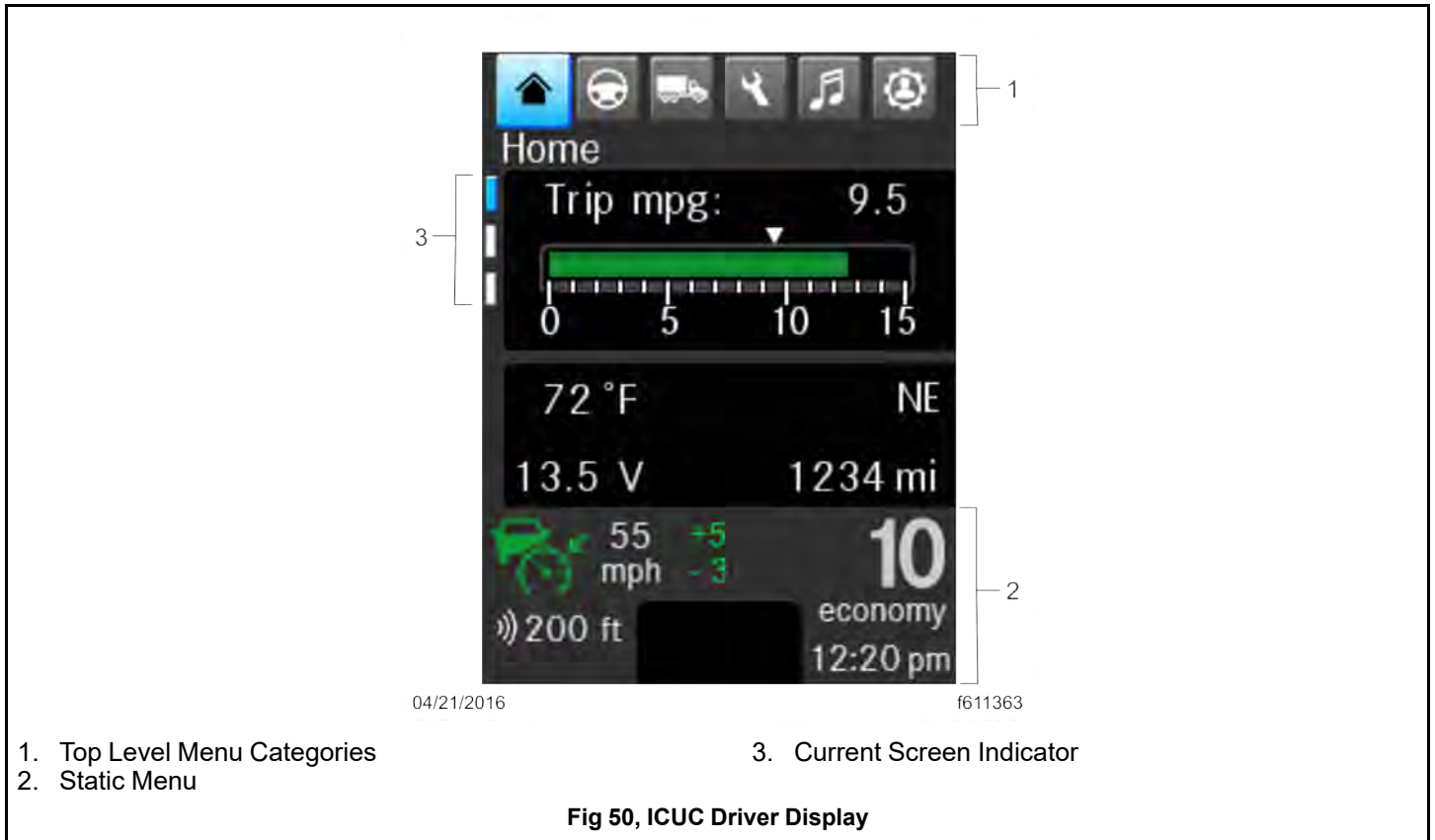

The ICUC top level menu categories allows a driver to quickly carry out common actions. Top level menu categories include Home, Drive Time Systems, Vehicle Operations, Maintenance, Infotainment, and User Settings. See Fig. 51, [Instrument Cluster Overview - ICUC](#).

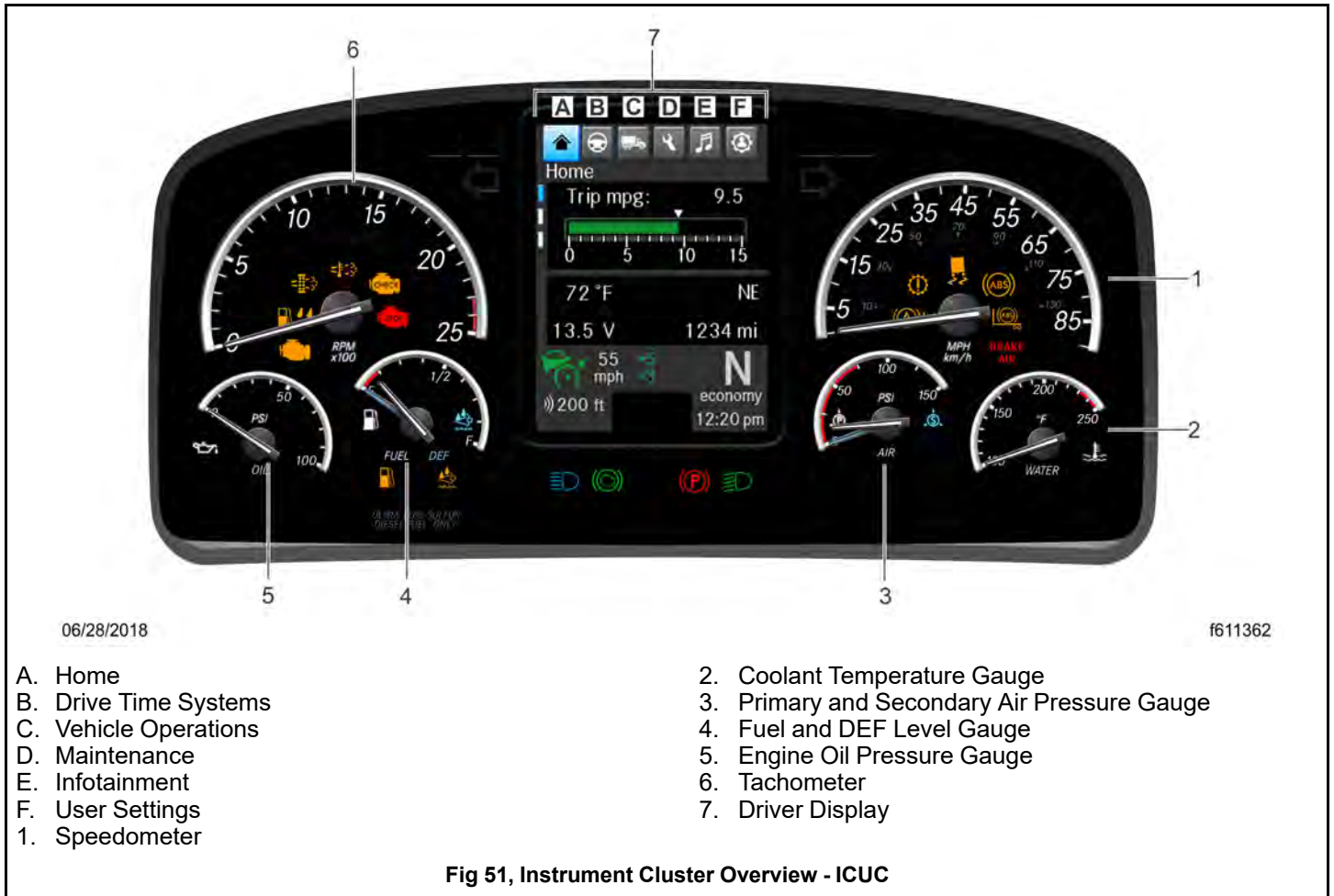

The static menu display shows vehicle speed, transmission gear indicators, cruise control settings, and a clock. Soft tell-tales are also displayed in this area. See Fig.52, [ICUC Static Display](#).

NOTE: Some optional features have icons in the static display area, for example, Optimized Idle status and Descent Control Mode.

If present, the screen indicator dashes communicate how many display screens are available in the current menu category. See Fig.50, [ICUC Driver Display](#).

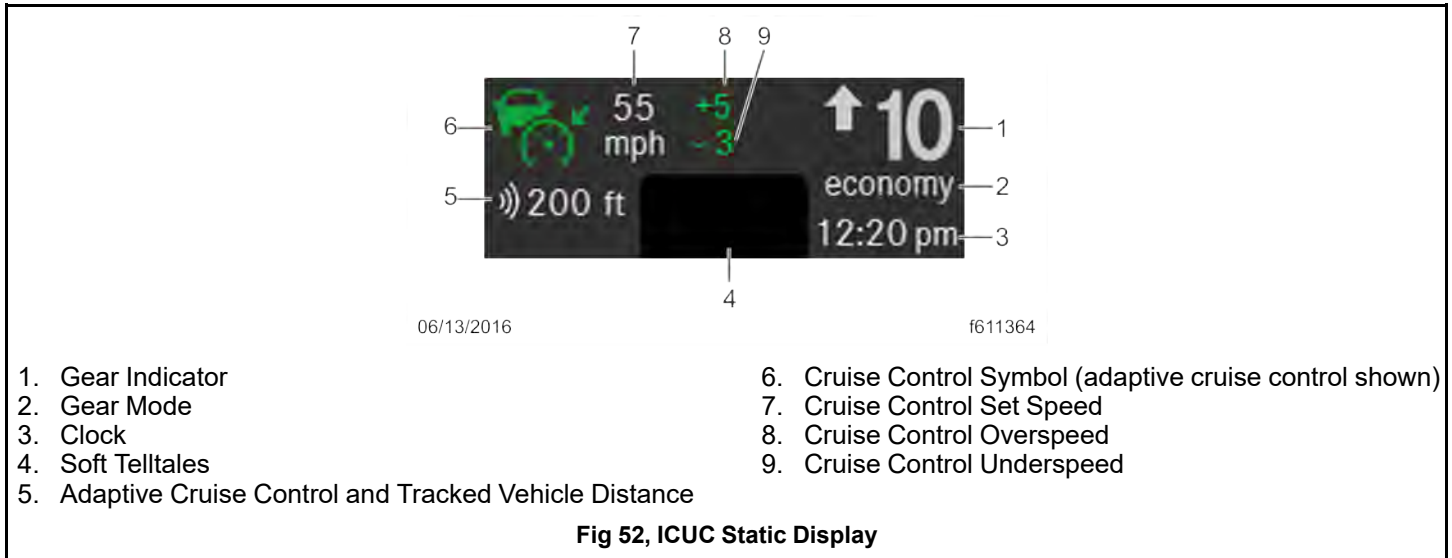

To navigate the ICUC menus, use the Menu Right and Menu Left switches on the steering wheel to move between the top-level menus.

Use the Menu Up and Menu Down buttons to move from screen to screen within the selected category.

See Fig.53, [ICUC Steering-Wheel-Mounted Switches](#) for an overview of steering wheel mounted switches.

For Quick Access Systems menus press the Quick Access System Settings button in the right-hand switch pod. If Quick Access Systems menus are not available, the button will bring up the home screen.

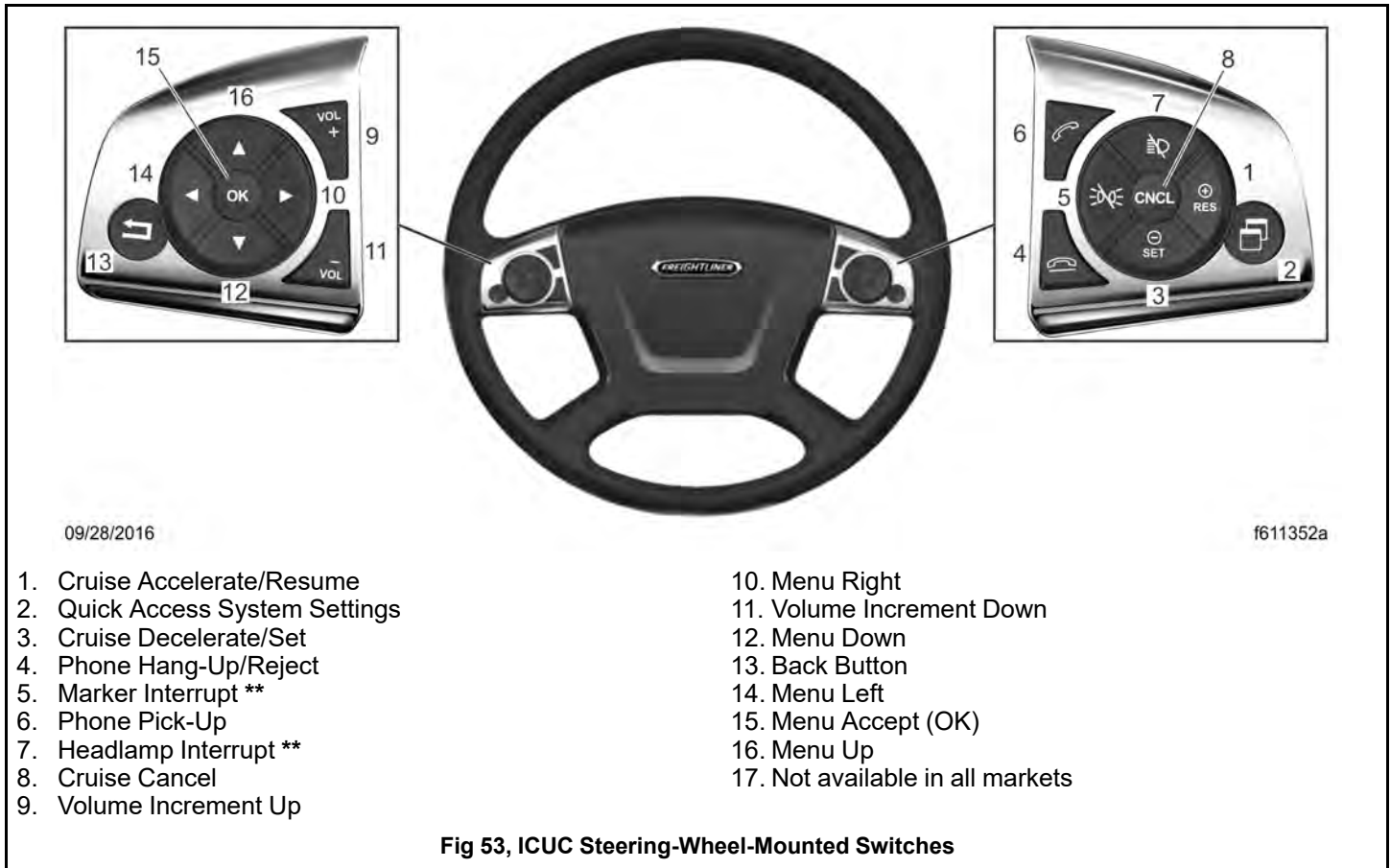

4.01.04 Time and Date

NOTE: Time and date are set automatically when the vehicle is equipped with a tachograph. When a vehicle is equipped with a tachograph only the time zone can be changed.

ICUC time and alarm clock settings are found under User Settings. See "Driver Display: ICUC" in this chapter for details.

The correct time and date is required for the following ICU functions to work:

- Alarm clock
- Maintenance
- Prognostics

4.01.05 Software Updates

A software update consists of three steps:

1. Downloading the software.
2. Installing the software.
3. Activating the software by restarting the system.

A popup message will appear when an update is available. In addition, the software update option in the diagnostics menu will be active.

The vehicle must be in neutral gear, the parking brake set, and the engine off before a software update can start. Once started, a software update cannot be cancelled.

During the software update process, progress messages will be provided. See Fig. 54, [Example ICUC Software Update Screens](#) for typical ICUC software update screens.



04/29/2019

f611643

Fig 54, Example ICUC Software Update Screens

If a software update is interrupted, the system will ask if you want to restart the process or inform you that the vehicle cannot be driven until the update is complete. If a software update fails, the system will attempt to revert to the previous version. A notification will appear when a software update has been successfully installed.

Failure to install software updates may make data less secure and/or mean vehicle systems are not operating at their best.

NOTE: An estimation of installation time will be given before the software update starts. Installation can take several minutes. During installation individual functions and controls will not be available or only available to a limited degree.

4.02 Driver Display Overview: ICUC

4.02.01 ICUC Alert Messages

Below is an overview of ICUC driver display screens and functions.

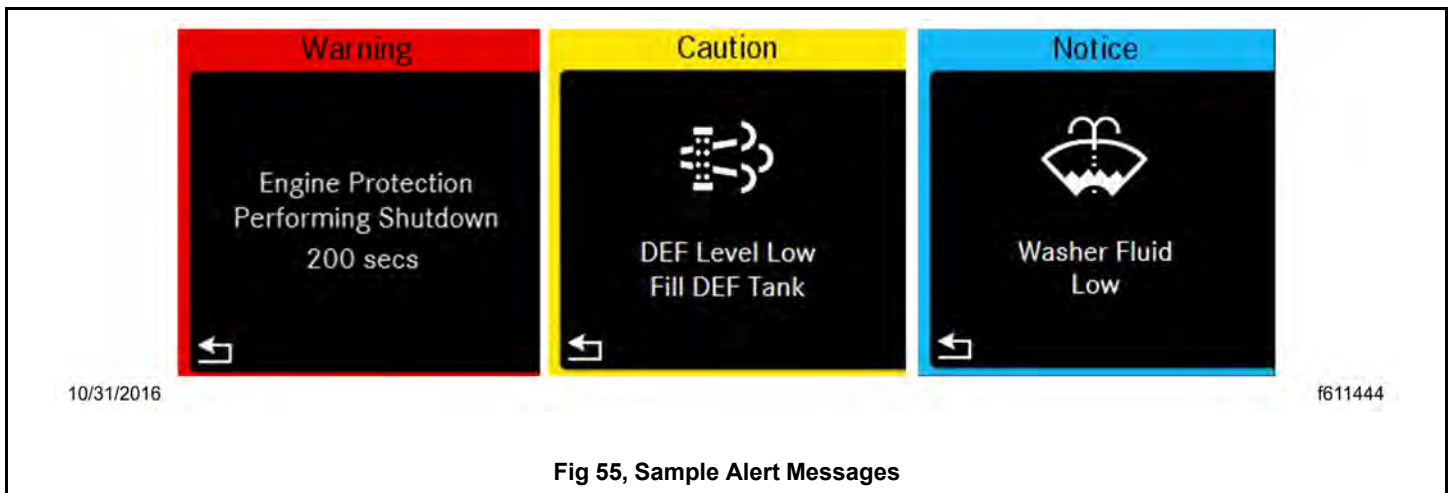

Fig 55, Sample Alert Messages

Alert messages are displayed when certain conditions occur. They include warnings, cautions, and notices that require the driver's attention. Not all alert messages are critical to the operation of the vehicle. More important messages take priority over less important messages. The header text and color indicates the priority of the on-screen message, listed from the highest to the lowest:

- Warning (red)
- Caution (amber)
- Status/Informational (blue, green, white, and grey)

Warnings alert the driver to situations or conditions that may pose a threat to control of the vehicle. Follow all instructions given in the message.

Cautions alert the driver to situations or conditions that may result in damage to vehicle components, or derating of engine power.

Status notices alert the driver to situations or conditions that may improve fuel efficiency or improve vehicle drivability.

See Fig. 55, [Sample Alert Messages](#) for typical alert messages.

ICUC Watch for Ice Popup

When ambient air temperature drops below 34°F (1°C), a Watch For ICE popup message will appear. See Fig. 56, [ICUC Watch for Ice Popup](#). Acknowledge and dismiss this message by pressing the back button in the left hand steering wheel switch pod.

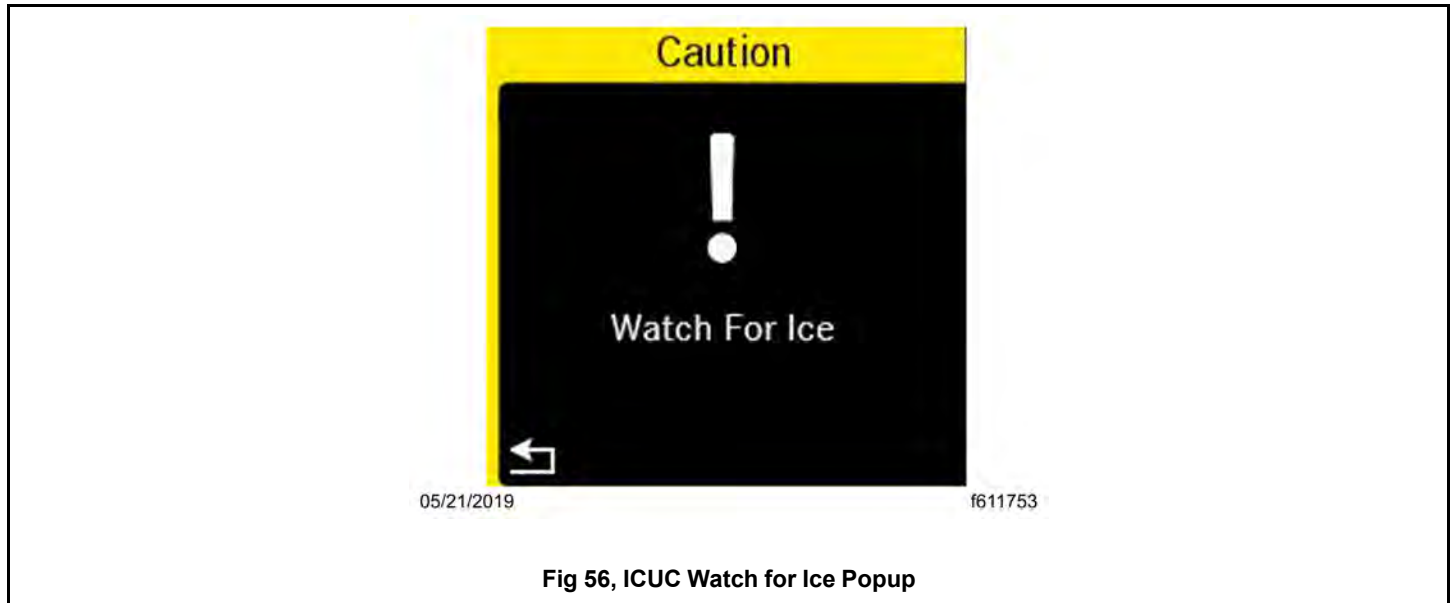

Fig 56, ICUC Watch for Ice Popup

An ambient air temperature below 34°F (1°C) will also cause a snowflake icon to appear next to the display temperature. The snowflake icon will display until the ambient air temperature rises to 37°F (3°C).

If the temperature drops below 34°F (1°C) after rising above 37°F (3°C), the Watch For ICE popup and snowflake will reappear.

4.02.02 ICUC Time and Alarm Settings

Below is an overview of ICUC driver display screens and functions.

Time Settings: Display Format

NOTE: Local Time Offsets can also be viewed under this menu.

In the ICUC, time can be displayed in 12 or 24 hour format. Time format is set under Time Settings under User Settings.

1. Select the gear icon to open the User Settings menu. The last settings menu accessed will open.
2. If not on the Settings Options List Screen, use the Up arrow in the left-hand steering wheel switch pod to move to this screen.
3. Press OK to access the settings menus.
4. Use the Down arrow in the left-hand steering wheel switch pod to get to Time.
5. Press OK to access Time.
6. Use the Right arrow to navigate from 12h to 24h or 24h to 12h.
7. Press OK on the left-hand steering wheel switch pod to choose an option.

Setting An Alarm

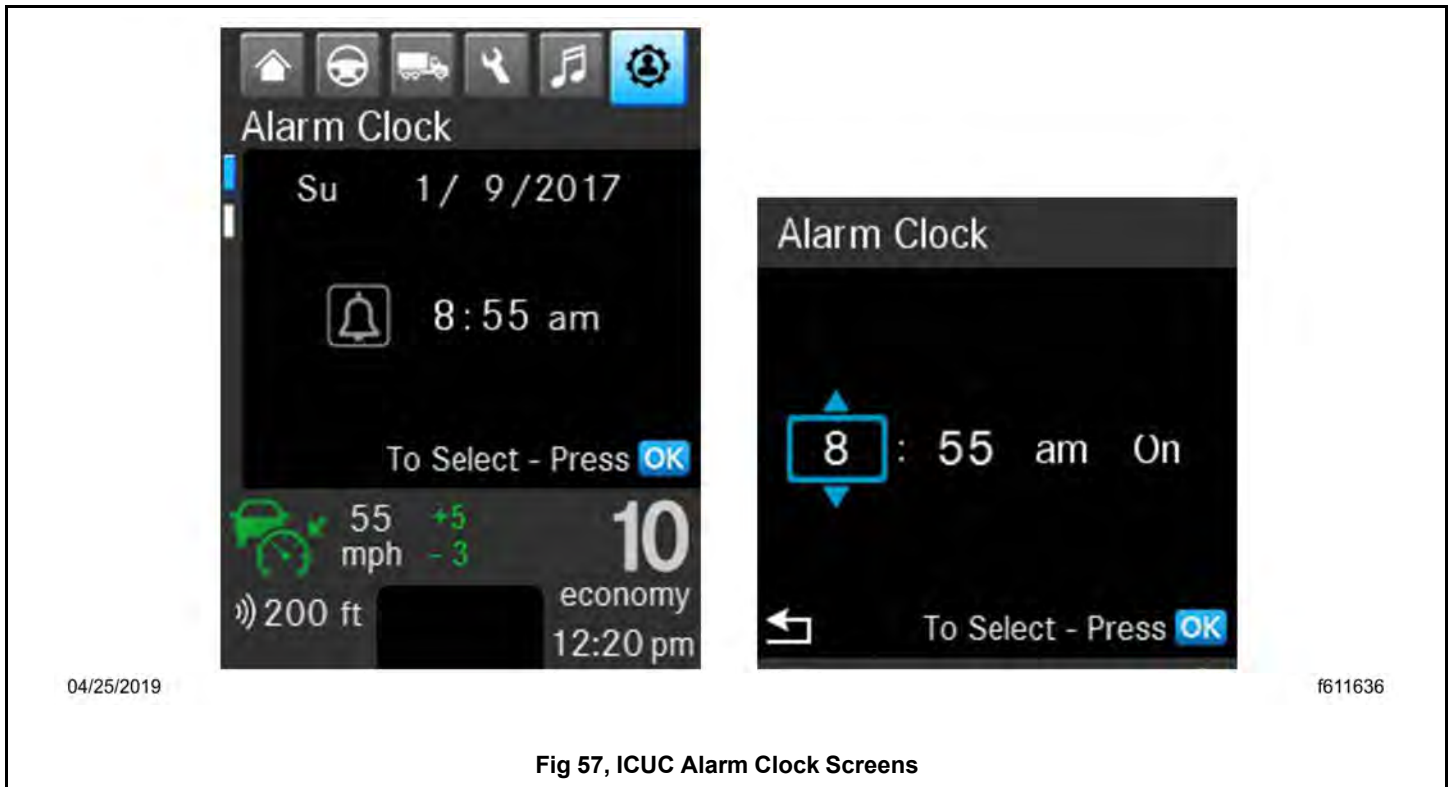

Fig 57, ICUC Alarm Clock Screens

In the ICUC, one alarm can be set under Alarms under the User Settings. See Fig.57, [ICUC Alarm Clock Screens](#).

The alarm triggers a repeated chirping sound as well as a alarm pop-up. Both can be dismissed by pressing the back button on the left hand steering wheel switch pod.

1. Select the gear icon to open the User Settings menu. The last settings menu accessed will open.
2. If not on the Alarms screen, use the Down arrow in the left-hand steering wheel switch pod to move to this screen.
3. Press OK to access the alarm clock options.
4. Use the Up and Down arrow to choose hour, minute, and am/pm and alarm status.
5. Press OK to set the alarm.

4.02.03 ICUC Driver Display Screens

The six ICUC top-level menu categories are:

- Basic Information
- Drive Time Systems
- Vehicle Operations
- Maintenance
- Infotainment
- User Settings

Quick Access Systems are also available via the right-hand steering wheel Quick Access System Settings button.

NOTE: Screens will vary depending on vehicle options. Some screens are accessible only when the vehicle is parked and the parking brake is on.

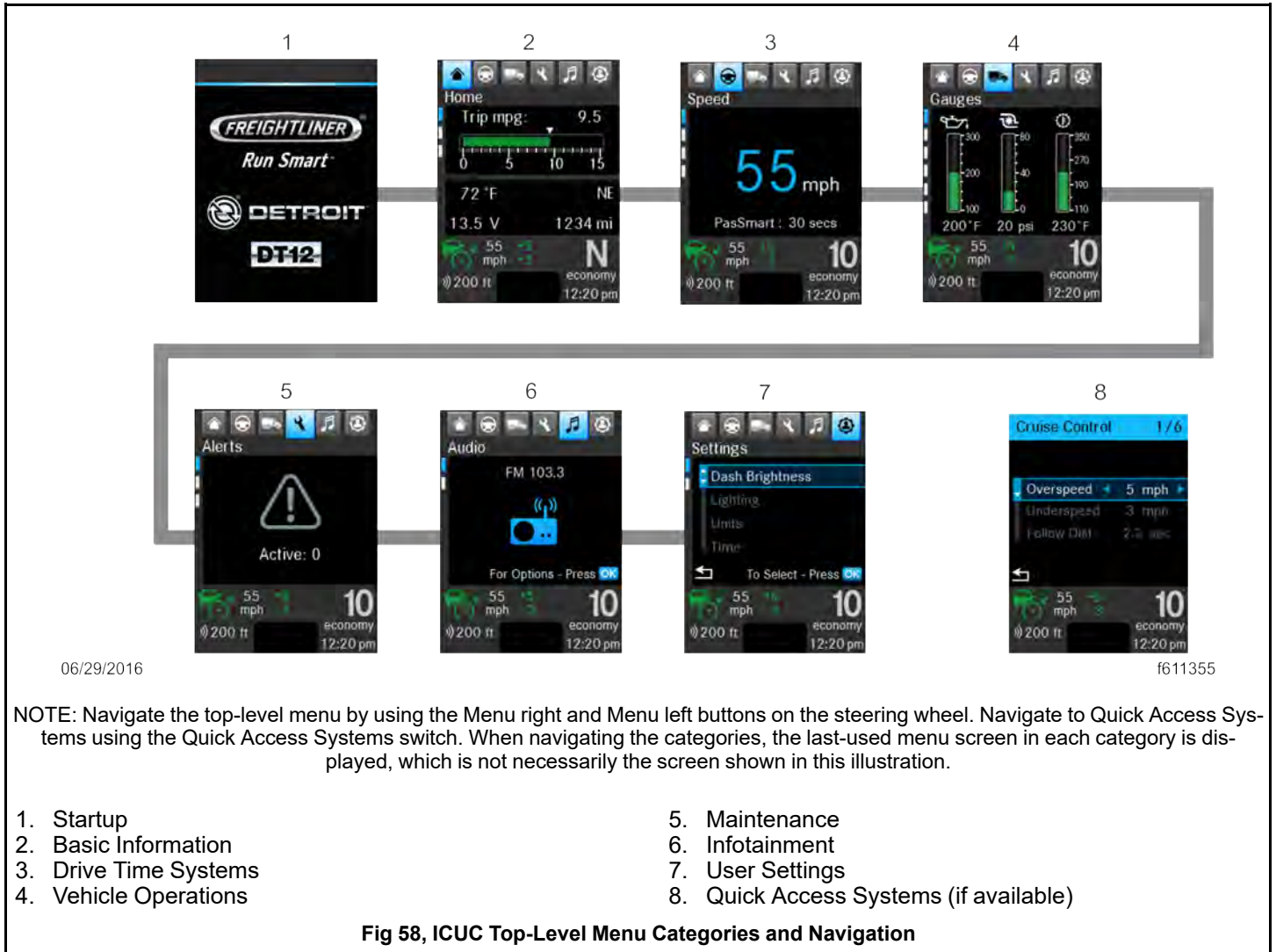

Basic Information Screens

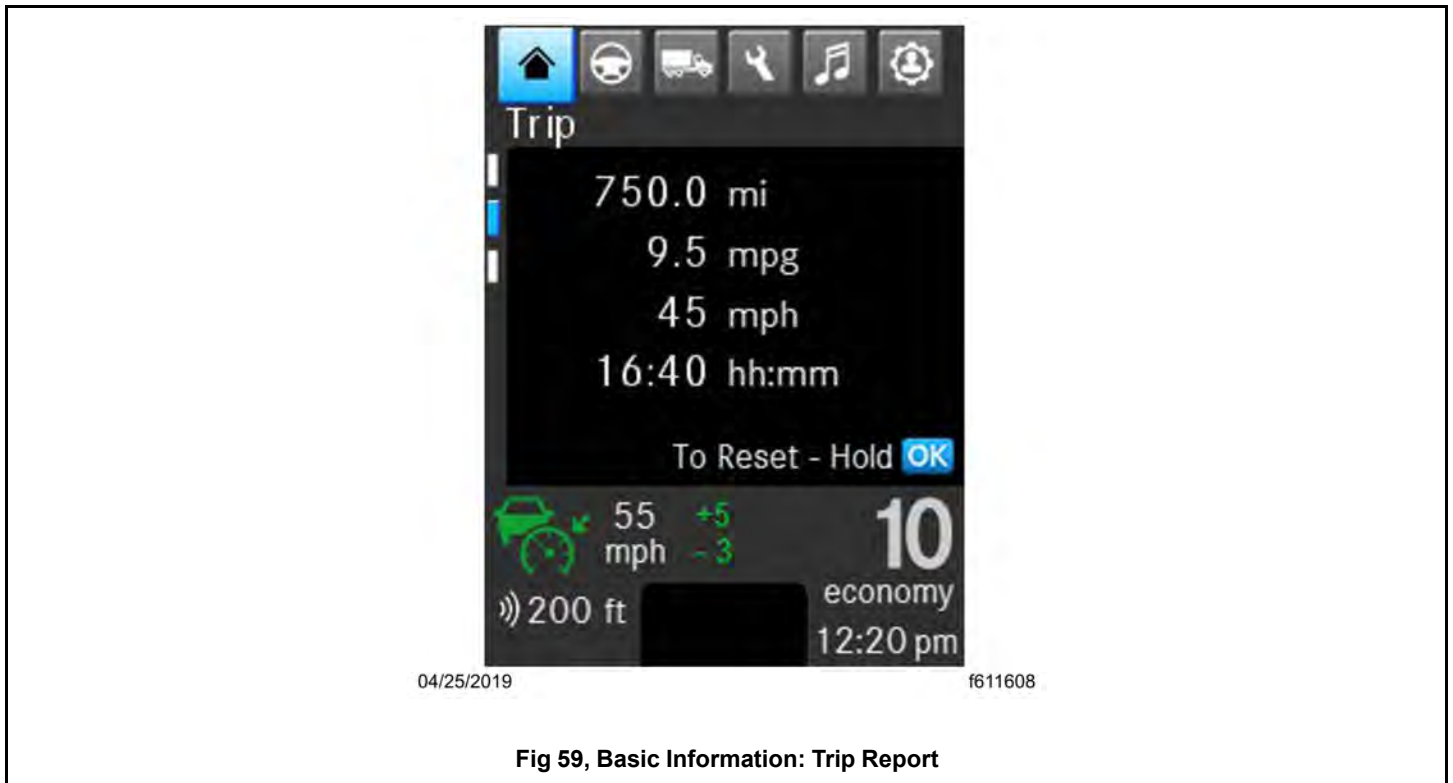

Fig 59, Basic Information: Trip Report

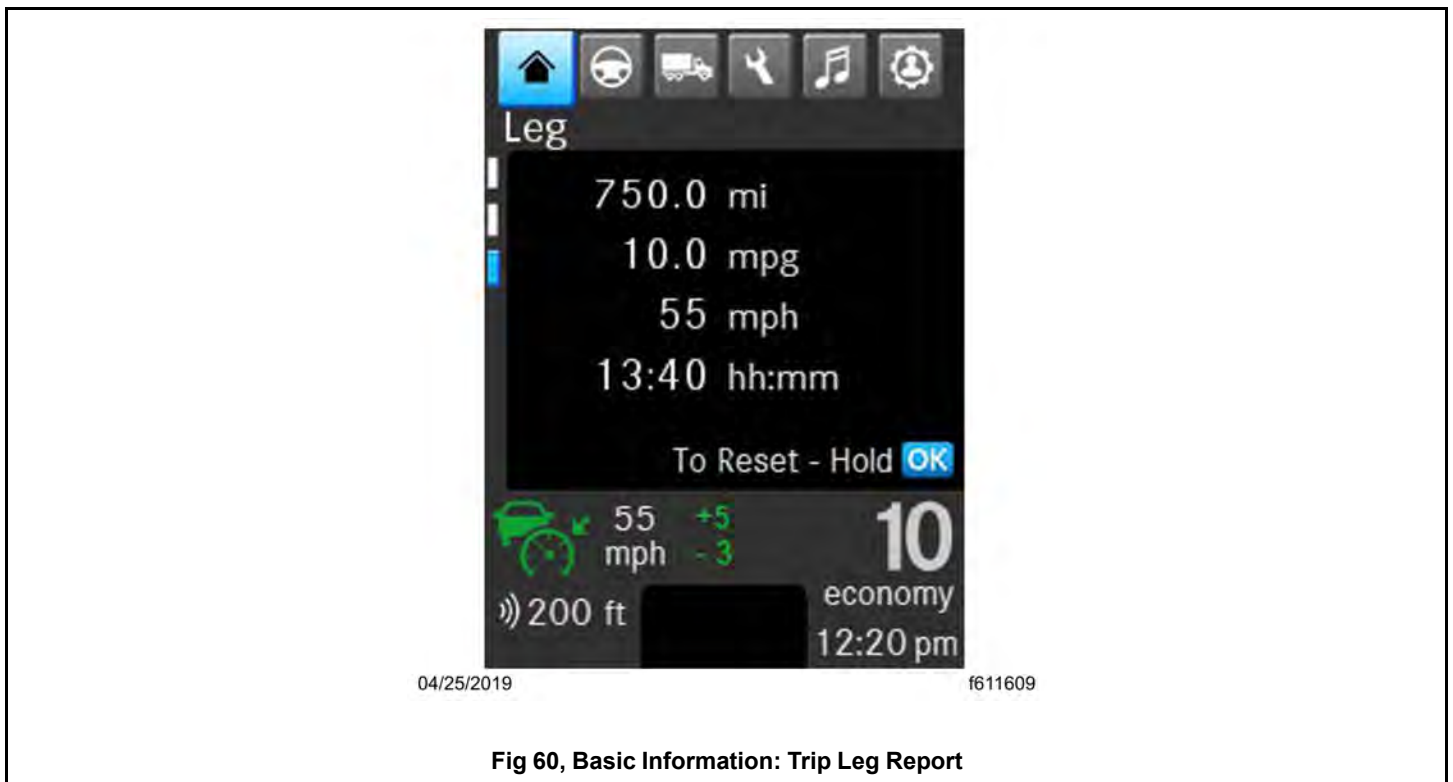

Fig 60, Basic Information: Trip Leg Report

There are currently three top-level menu options under Basic Information:

- Home
- Trip
- Leg

The Home screen displays a fuel consumption bar graph, the current outside temperature, the vehicle charging system voltage, compass direction of travel, and odometer. See Fig.58,[ICUC Top-Level Menu Categories and Navigation](#).

The Trip report screen displays calculations based on the engine run time such as trip mpg. See Fig. 59,[Basic Information: Trip Report](#).

The trip Leg report screen which displays calculations based on engine run time such as length of trip leg, average speed, hours. See Fig.60,[Basic Information: Trip Leg Report](#).

Drive Time Systems Screens



Fig 61, Drive Time Systems: Driver Assistance

There are currently four menu options under Drive Time Systems:

- Speed
- Driving Assistance
- Eco Driver Feedback (discontinued in January 2020)
- Video

The Speed screen shows the current vehicle speed as well as temperature, odometer and PasSmart information. See Fig. 58,[ICUC Top-Level Menu Categories and Navigation](#).

The Driving Assistance screens, depending on systems installed, show lane departure warnings, adaptive cruise control, active lane assist, traffic sign display, and/or side guard assist. See Fig.61,[Drive Time Systems: Driver Assistance](#).

The Eco Driver Feedback screens display bar graphs measuring cruise control usage, smooth acceleration, and gentle braking. For fuller explanation, see the Digital Instruments: ICUC section.

Depending on systems installed, video is recorded when active safety systems are engaged or unsafe driving conditions are detected.

Vehicle Operations Screens

There are currently five top-level menu options under Vehicle Operations:

- Gauges
- Diesel Particulate Filter
- Tire Pressure Monitoring
- Locks
- Vehicle Settings

For information on gauge screens and Tire Pressure Monitoring see "Instruments and Systems: ICUC" in this chapter. Information on diesel particulate filter monitoring is covered in chapter **Chapter 14** Emissions and Fuel Efficiency. Information on Transmission Prognostics is covered in **Chapter 17**, Automated and Automatic Transmissions. For information on Locks see **Chapter 19**, Drive Axles.



Fig 62, Vehicle Operations: Vehicle Settings

The Vehicle Settings screen provides access to vehicle system settings such as cruise control, transmission, attention assist, and idle adjust. See Fig.62, [Vehicle Operations: Vehicle Settings](#).

ICUC Maintenance Screens

There are currently five top-level menu options under Maintenance:

- Alerts
- Diagnostics

- Engine Maintenance
- Trans Prognostics
- Maintenance System

The maintenance screens are used to retrieve fault codes and other diagnostic and service information pertaining to the vehicle.

The Alerts screens show all active notices, cautions, and warnings. See Fig.63, [Maintenance: Alerts](#).

Fault codes are color-coded to indicate the severity of the fault. Red indicates a condition that may pose a threat to control of the vehicle. Amber indicates a condition that may result in damage to vehicle components or derating of engine power. Blue, grey, and green are used to indicate component status.



04/25/2019

f611622

Fig 63, Maintenance: Alerts

The Diagnostics screens show active diagnostic trouble codes and if a software update is available. See Fig. 64, [Maintenance: Diagnostics](#).



Fig 64, Maintenance: Diagnostics

The Engine Maintenance screen shows engine hours. See Fig.65, [Maintenance: Engine Maintenance](#).

The Maintenance System screens give information about when maintenance is required. See "Instruments and Systems: ICUC" in this chapter for more details.



Fig 65, Maintenance: Engine Maintenance

ICUC User Settings Screens

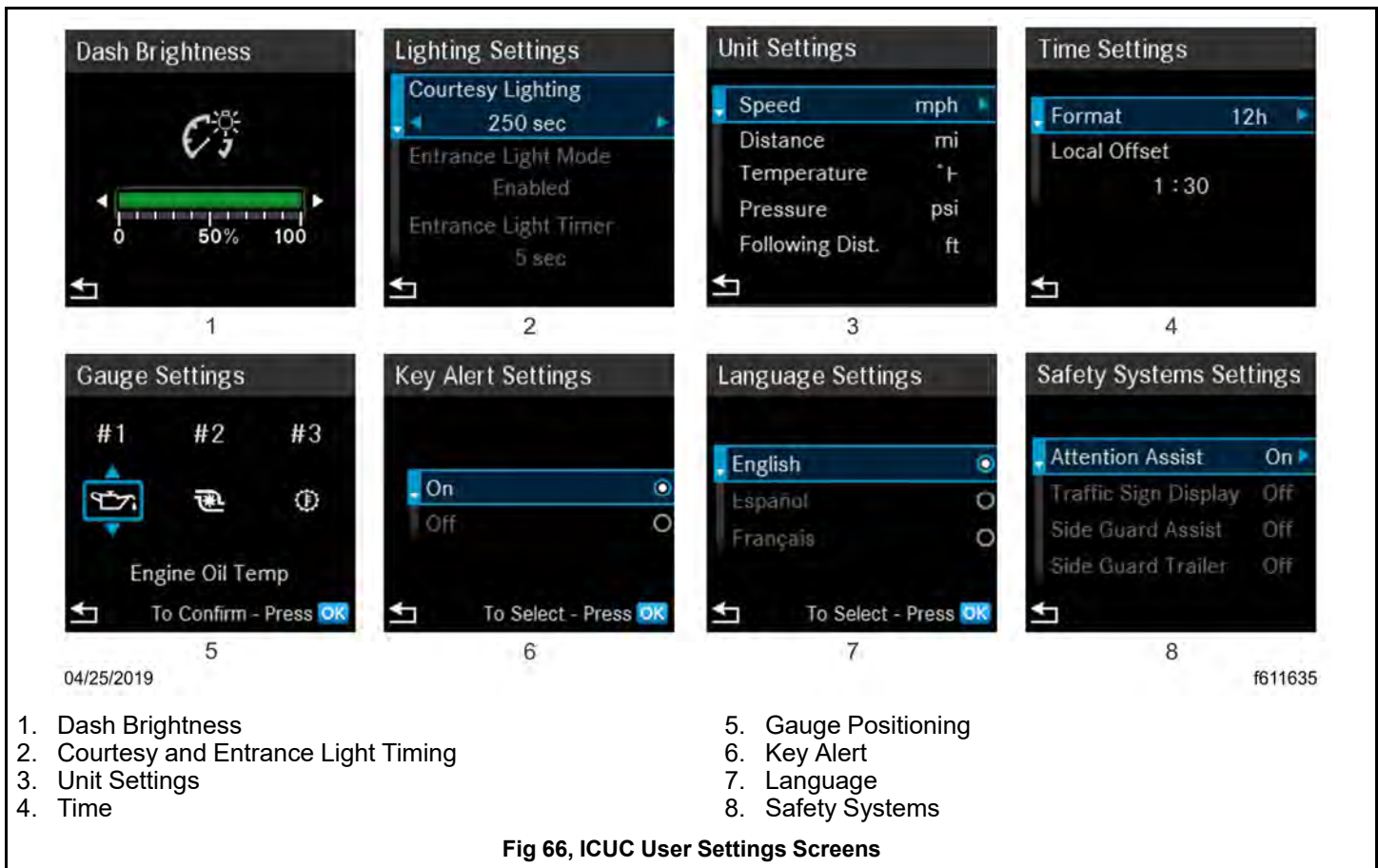

The ICUC Setting Options List screens (see Fig.66, [ICUC User Settings Screens](#)) allow the driver to choose the following:

- Dash Brightness
- Lighting Settings
- Units Settings
- Time Settings
- Gauge Settings
- Key Alert Settings
- Language Settings
- Safety System Settings

Dash Brightness allows for setting the brightness of the dashboard display.

Lighting Settings controls if the courtesy and entrance lights are on and how long they stay on.

Unit Settings controls the measurement values for speed, distance traveled, temperature, pressure, and following distance.

Time Settings controls the time display format (12h/24h) and local time zone offsets.

Gauge Settings allow the driver to change the order in which gauges are displayed on the gauge screens.

Key Alert Settings control if the key alerts is on or off.

Language Settings allow the driver to set the ICU language to be in either English (American), Spanish (Mexican), or French (Canadian).

Safety System Settings allow the driver to turn safety features such as Attention Assist, Traffic Sign Display, Side Guard Assist, and Side Guard Trailer on or off.

ICUC Quick Access Systems Screens

Quick Access Screens are activated by a button on the right hand steering wheel pod. There are up to six top-level menu options:

- Hysteresis
- Cruise Control
- Transmission
- Engine Idle Adjust
- Power Take Off
- Optimized Idle

Hysteresis allows the driver to set the overspeed and underspeed in mph (km/h). See Fig. 67, [Quick Access Screen: Hysteresis](#).

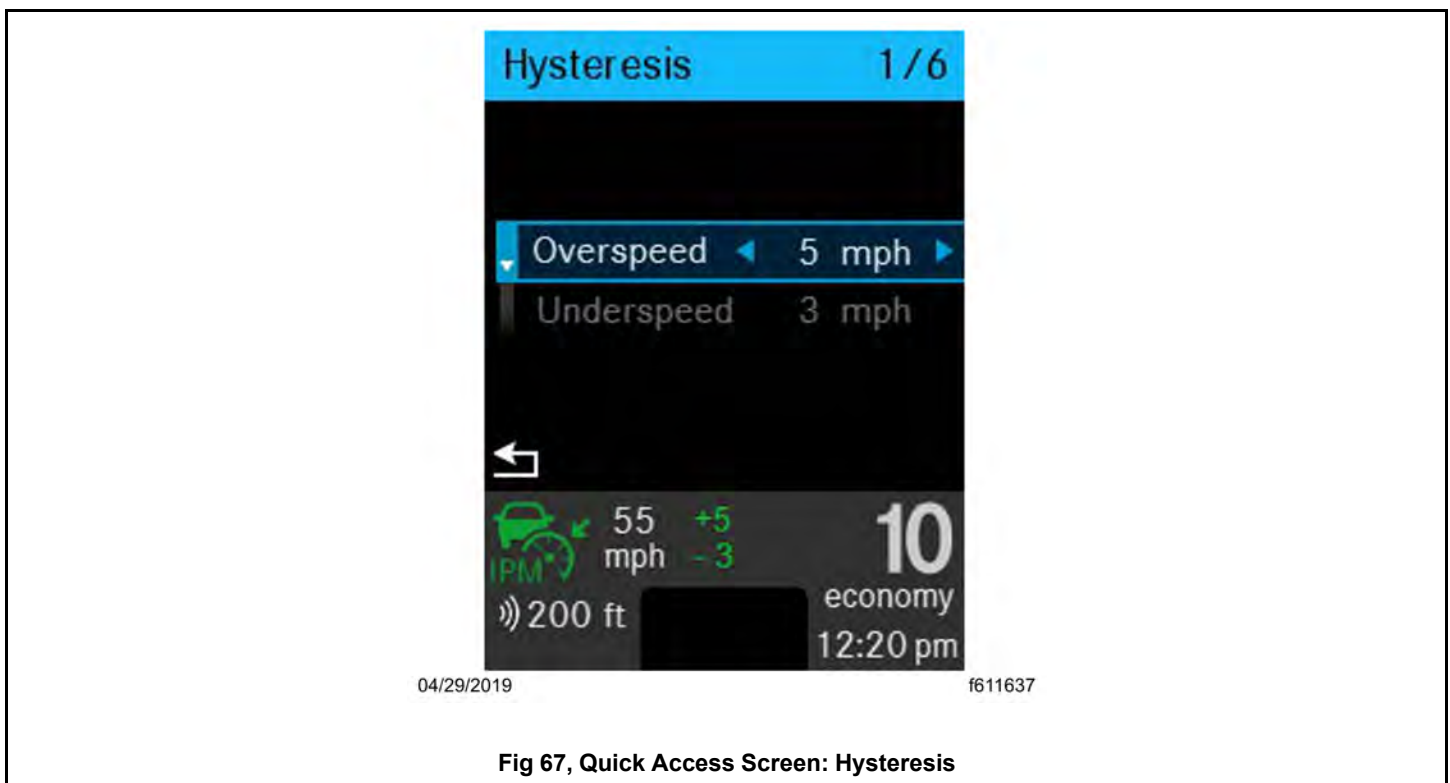

Fig 67, Quick Access Screen: Hysteresis

Cruise Control allows the driver to control such features as active lane assist, lane position, and following distance. See Fig. 68, [Quick Access Screen: Cruise Control](#). For more information see "Instruments and Systems: ICUC" in this chapter.

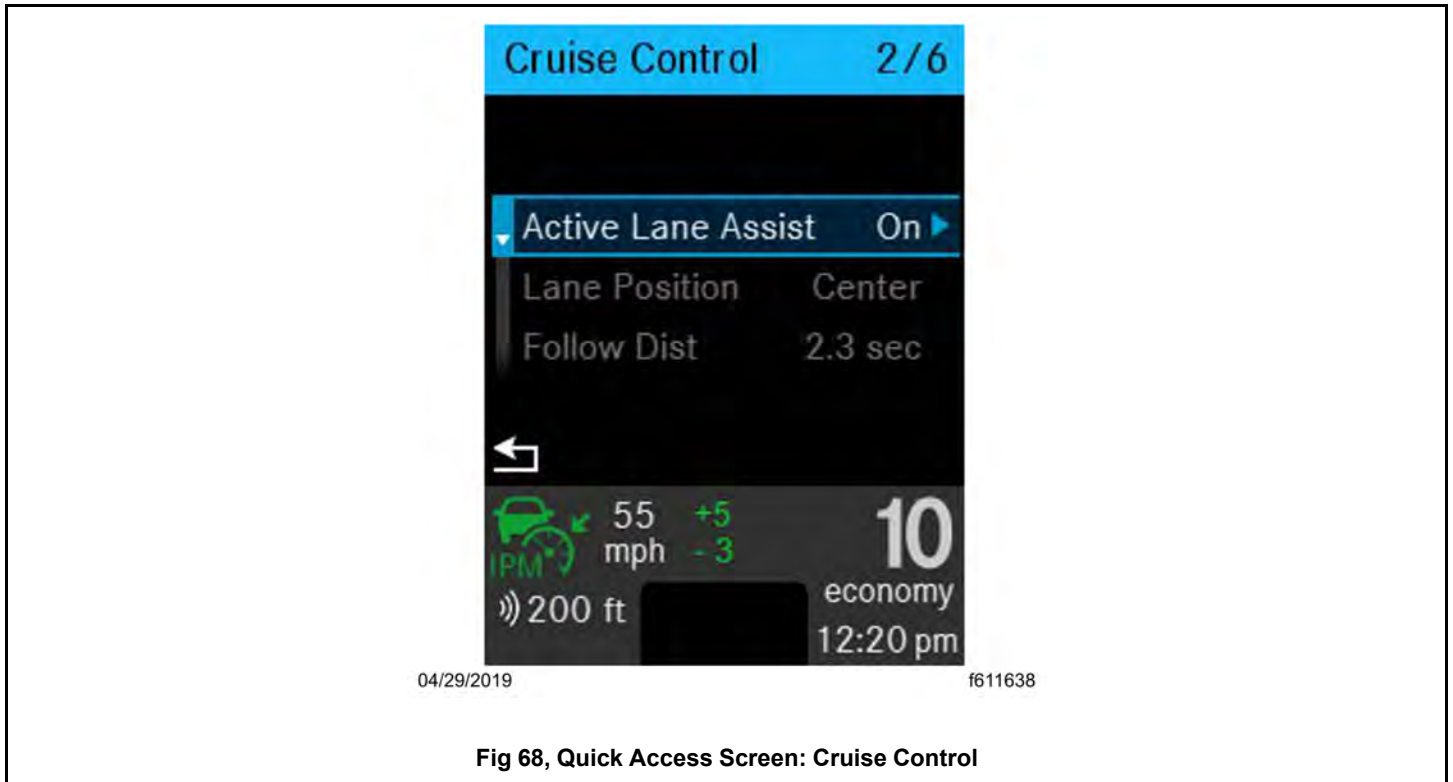

Fig 68, Quick Access Screen: Cruise Control

Transmission allows the driver to turn the creep mode or eCoast feature on or off. See Fig. 69, [Quick Access Screen: Transmission](#). See "Instruments and Systems: ICUC" in this chapter for more information.

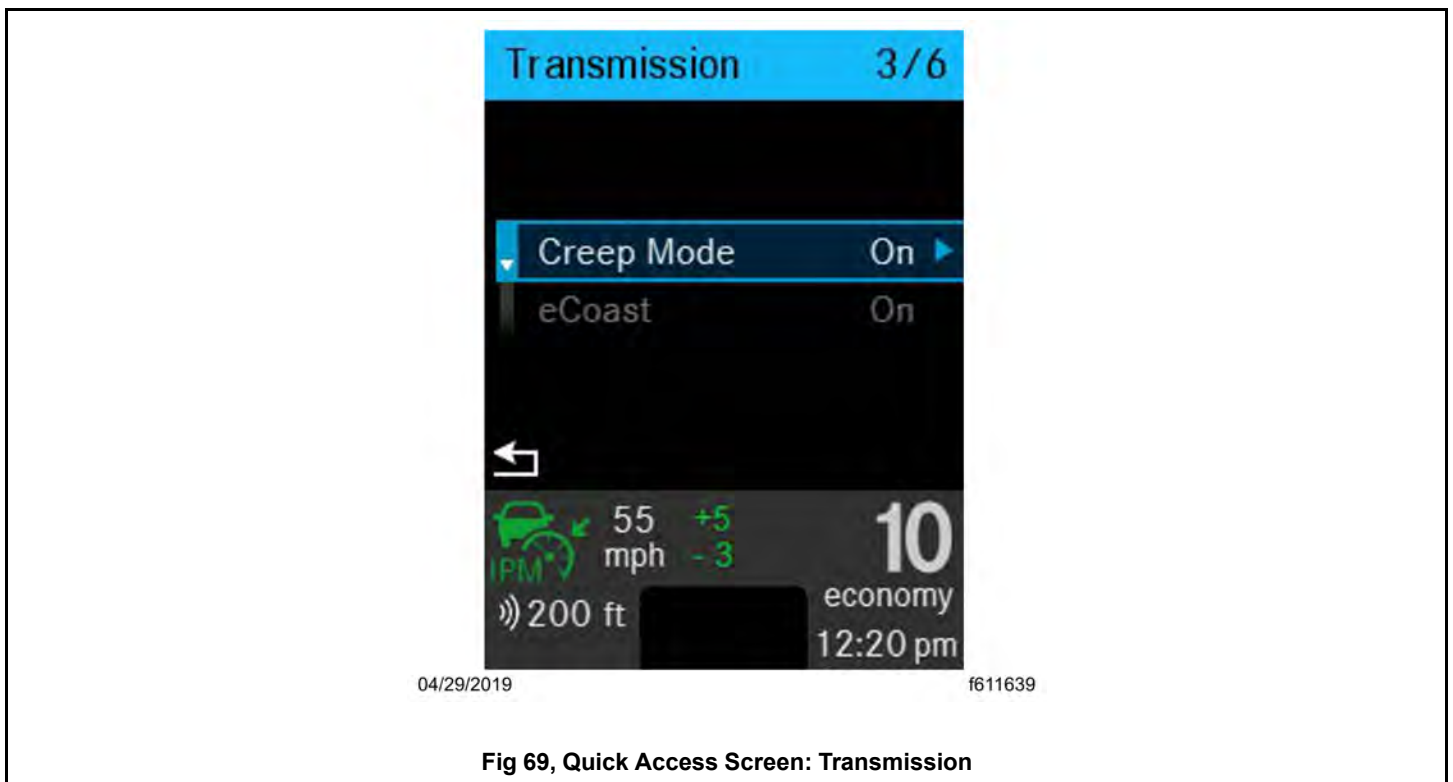

Fig 69, Quick Access Screen: Transmission

Engine Idle Adjust allows the driver to adjust or deactivate the engine idle. It is not available when the vehicle is in motion. See Fig.70,[Quick Access Screen: Engine Idle Adjust](#). For more information see "Instruments and Systems: ICUC" in this chapter.

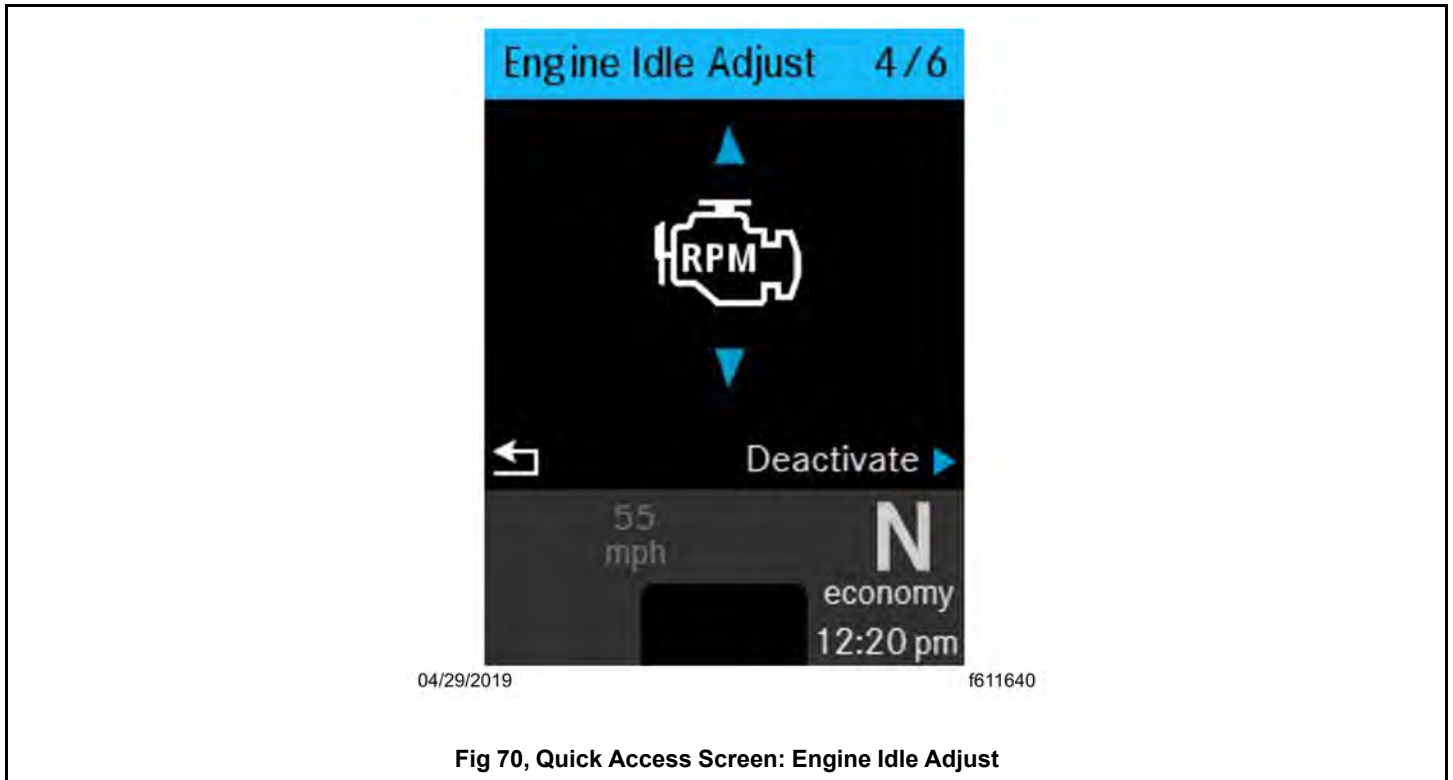

Fig 70, Quick Access Screen: Engine Idle Adjust

Power Take Off allows the driver to customize the amount of power being transferred. See Fig. 71,[Quick Access Screen: Power Take Off \(PTO\)](#).



Fig 71, Quick Access Screen: Power Take Off (PTO)

The Optimized Idle screens allow the driver to choose the optimized idle mode and enable or disable the feature. For more information see "Instruments and Systems: ICUC" in this chapter

4.03 Digital Gauges and System Monitors: ICUC

4.03.01 ICUC Gauges

In the ICUC there are six digital gauges and two system screens for the Diesel Particulate Filter (DPF), and the Tire Pressure Monitoring System (TPMS).

The six digital gauges under the Vehicle Operations menu of the driver display are:

- Engine Oil Temperature
- Turbo Boost Pressure
- Transmission Oil Temperature
- Front Axle Oil Temperature
- Rear Axle Oil Temperature
- Application Air Pressure

In the ICUC, if a value measured by a digital gauge exceeds the normal range, an amber caution or red danger popup message will appear. However the bar graph color will remain green and the bar graph icons will remain white.

NOTE: The order of ICUC digital gauges and therefore the screen on which they display can be changed under Gauge Settings under Settings.

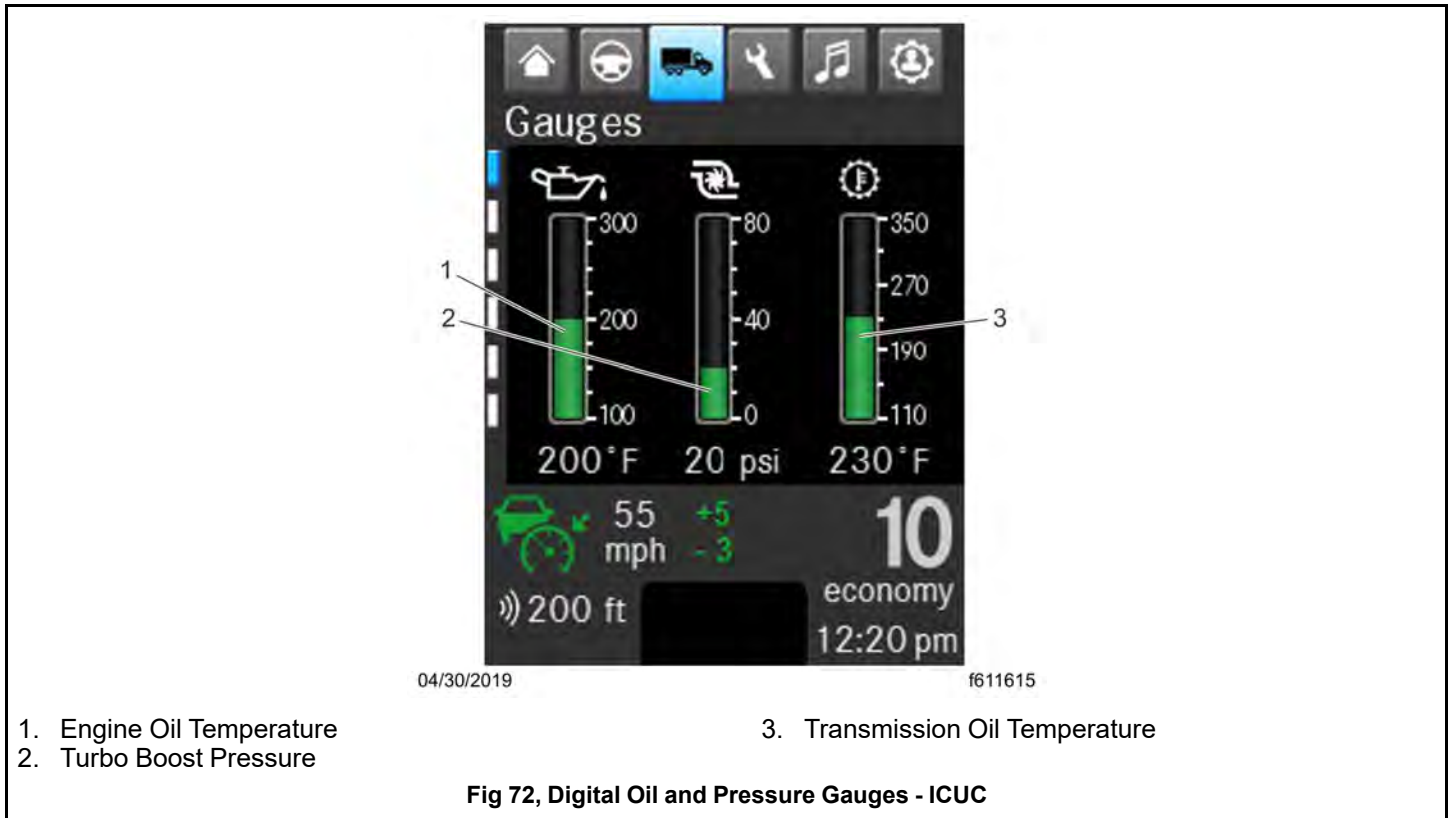

4.03.02 Engine Oil Temperature Gauge



NOTICE:

A sudden increase in oil temperature that is not caused by a load increase may indicate mechanical failure. Bring the vehicle to a safe stop and investigate the cause to prevent further damage. Do not operate the engine until the cause has been determined and corrected.

During normal operation, the optional engine oil temperature gauge (see Fig.73,[Digital Oil and Pressure Gauges - ICUC](#)) should read in the following temperature range:

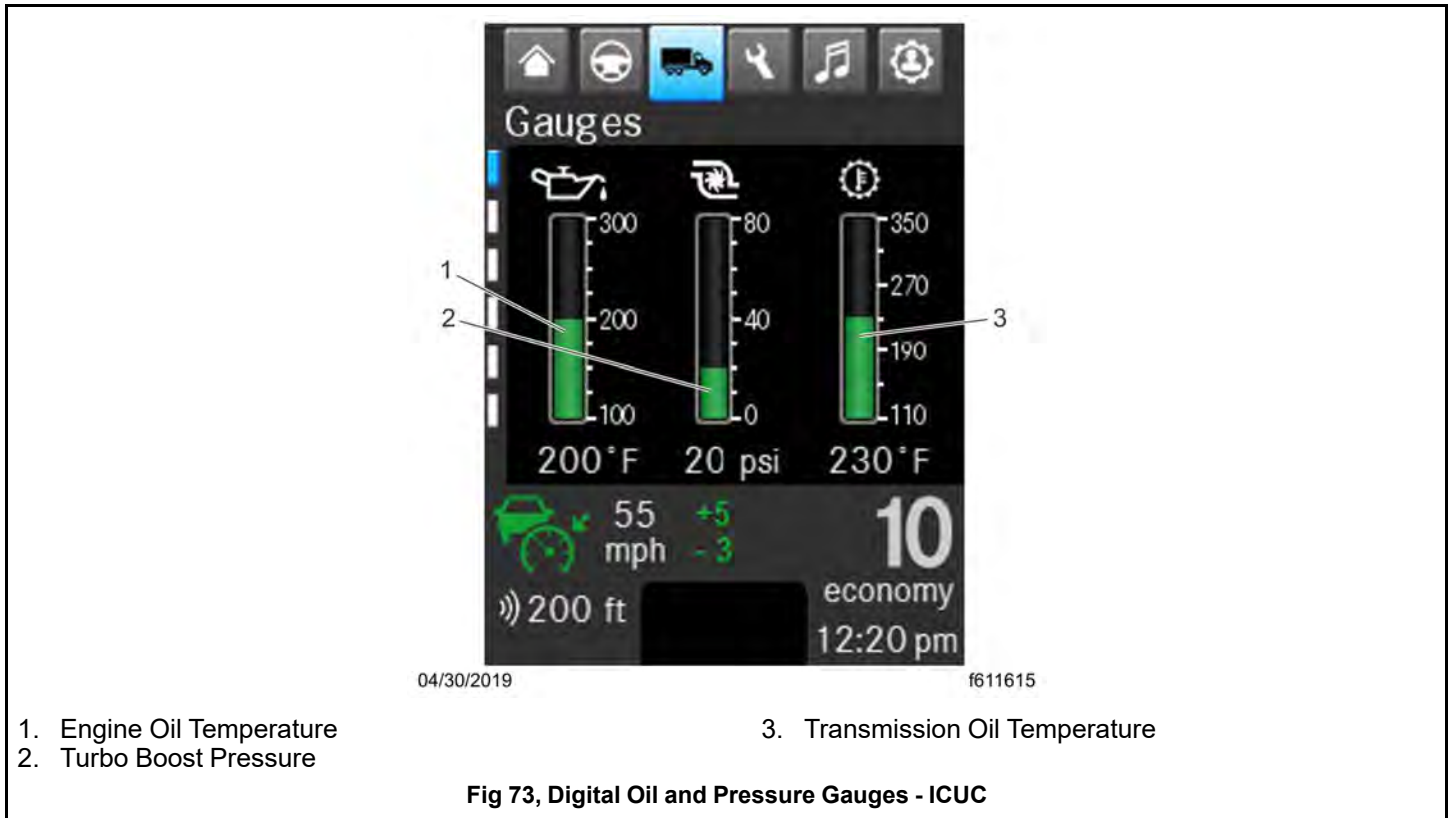

- 200 to 260°F (93 to 126°C) for Detroit and Cummins engines

Under heavy loads, such as when climbing steep grades, temperatures that exceed the normal oil temperature range for a short period are not unusual. If the temperature returns to normal when the load decreases, there is no problem.

4.03.03 Turbocharger Boost Pressure Gauge

The turbocharger boost pressure gauge (see Fig.74,[Digital Oil and Pressure Gauges - ICUC.](#)) indicates the pressure in the intake manifold, in excess of atmospheric pressure, being created by the turbocharger.

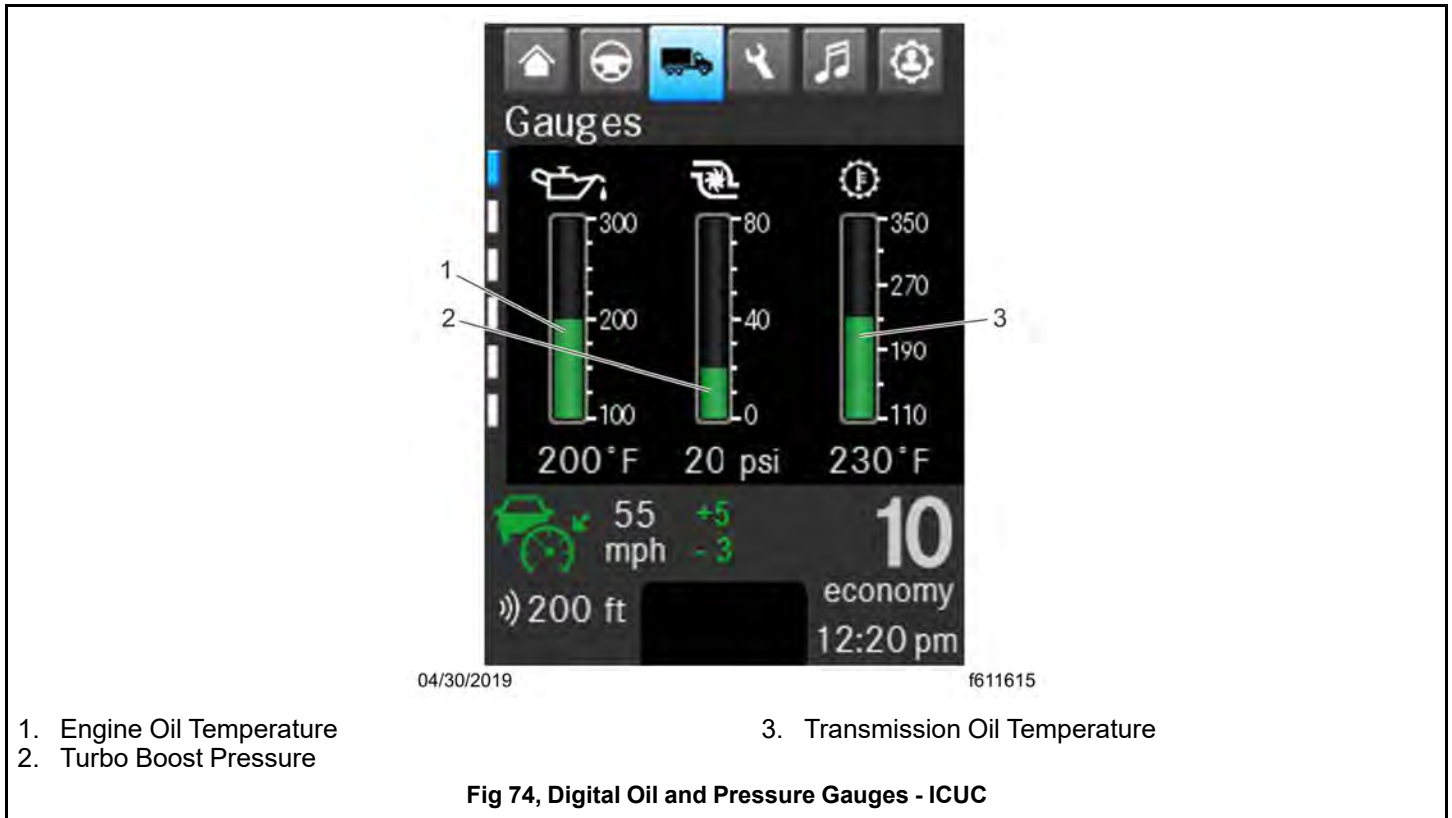

4.03.04 Transmission Oil Temperature Gauge

The transmission oil temperature gauge, (see Fig.75,[Digital Oil and Pressure Gauges - ICUC](#)) measures the transmission lubricant operating temperature. Temperatures vary by application, but the transmission fluid temperature gauge reading should not exceed 250°F (121°C).

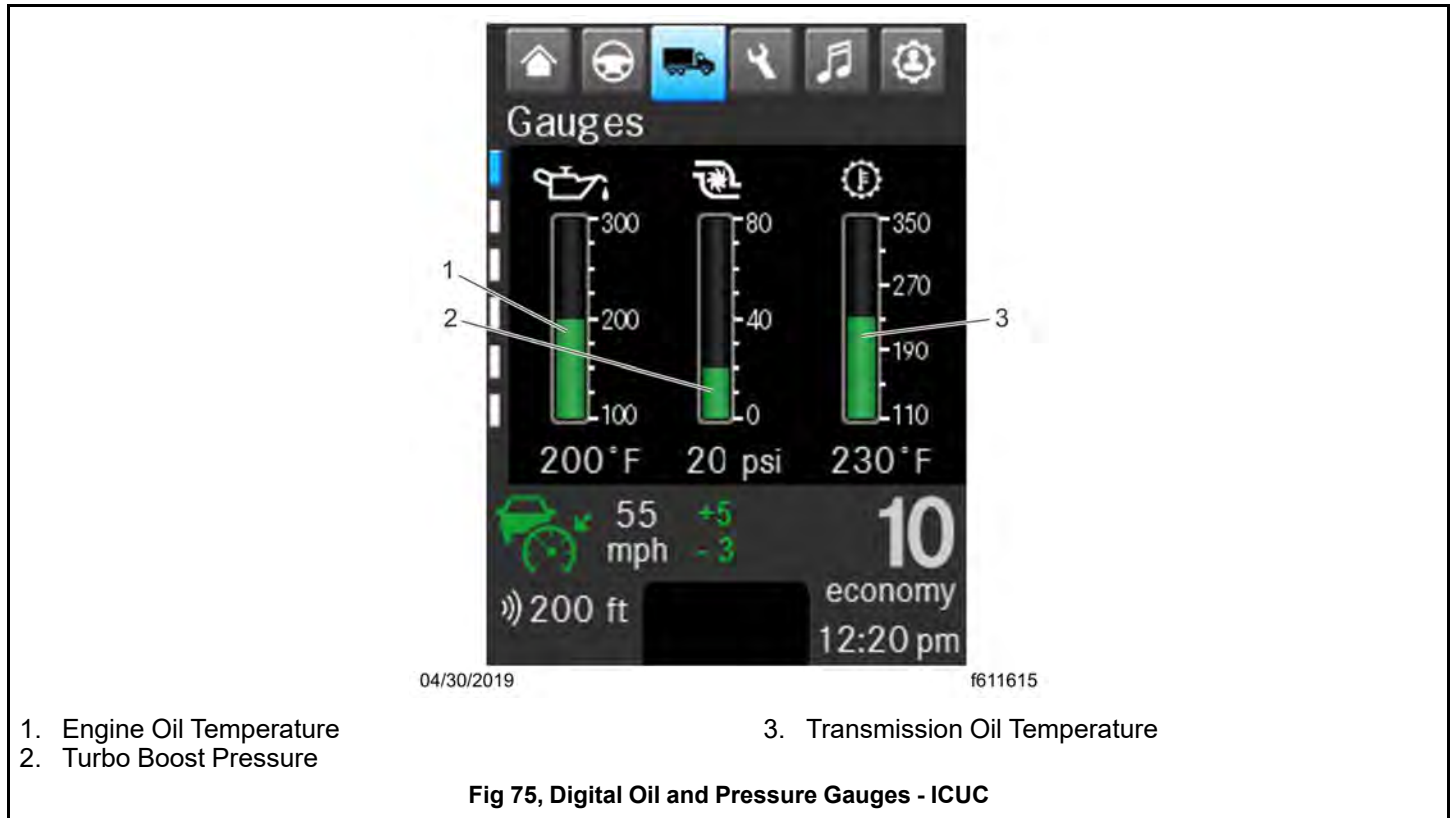

NOTICE:

A sudden increase in transmission fluid temperature that is not caused by a load increase may indicate mechanical failure. Bring the vehicle to a safe stop and investigate the cause to prevent further damage. Do not operate the vehicle until the cause has been determined and corrected.

Under heavy loads, such as when climbing steep grades, temperatures that exceed the normal oil temperature range for a short period are not unusual. If the temperature returns to normal when the load decreases, there is no problem.

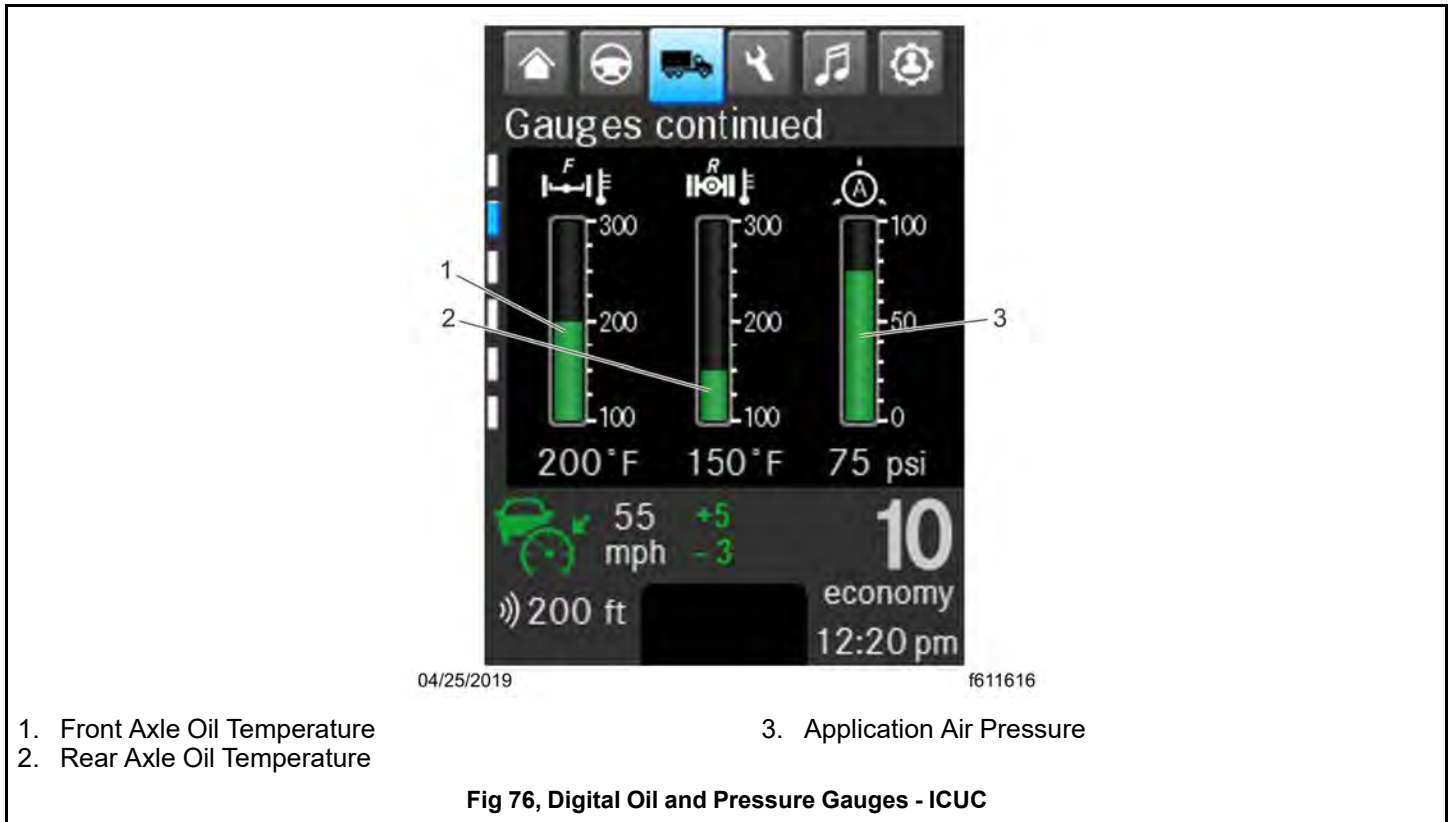

4.03.05 Drive Axle Oil Temperature Gauges

**NOTICE:**

A sudden increase in oil temperature that is not caused by a load increase may indicate mechanical failure. Bring the vehicle to a safe stop and investigate the cause to prevent further damage. Do not operate the vehicle until the cause has been determined and corrected.

During normal operation, drive axle oil temperature gauges (see Fig.77, [Digital Oil and Pressure Gauges - ICUC](#)) should read as follows:

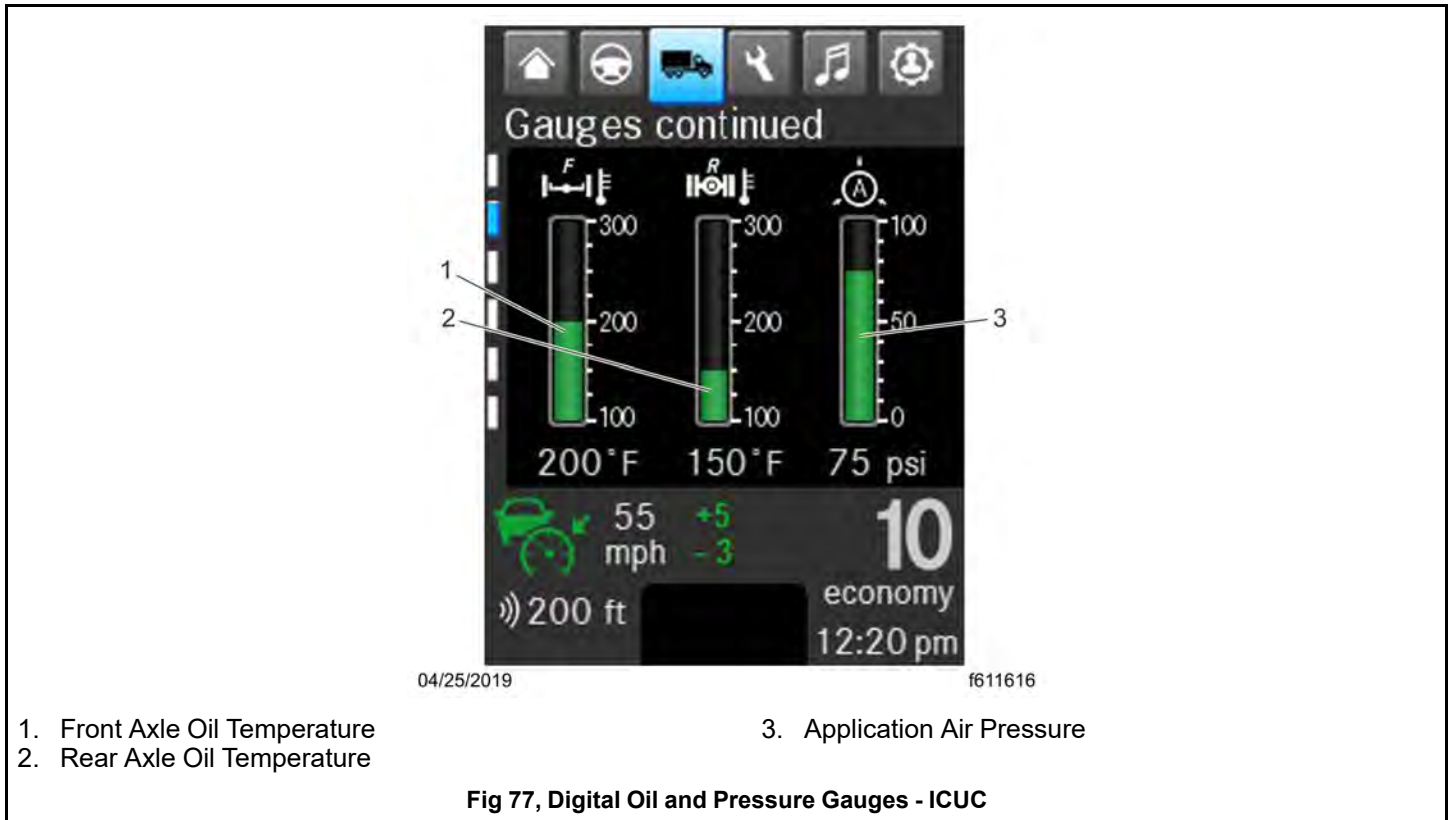

- 160 to 220°F (71 to 104°C) for Detroit® Classic Model 2, 4, and 6 axles.
- 160 to 329°F (71 to 165°C) for Detroit® New Final Drive (NFD) axles.
- 160 to 329°F (71 to 165°C) for Detroit® Adaptive Tandem 6 X 4 axles.
- 160 to 275°F (71 to 135°C) for Meritor drive axles.
- 180 to 200°F (82 to 93°C) for Dana Spicer® drive axles.

Under heavy loads, such as when climbing steep grades, temperatures that exceed the normal oil temperature range for a short period are not unusual. If the temperature returns to normal when the load decreases, there is no problem.

4.03.06 Application Air Pressure Gauge

The application air pressure gauge (see Fig.78, [Digital Oil and Pressure Gauges - ICUC](#)) registers the air pressure being used to apply the brakes. The gauge will not register air pressure until the foot brake pedal is depressed or the trailer hand brake is applied.

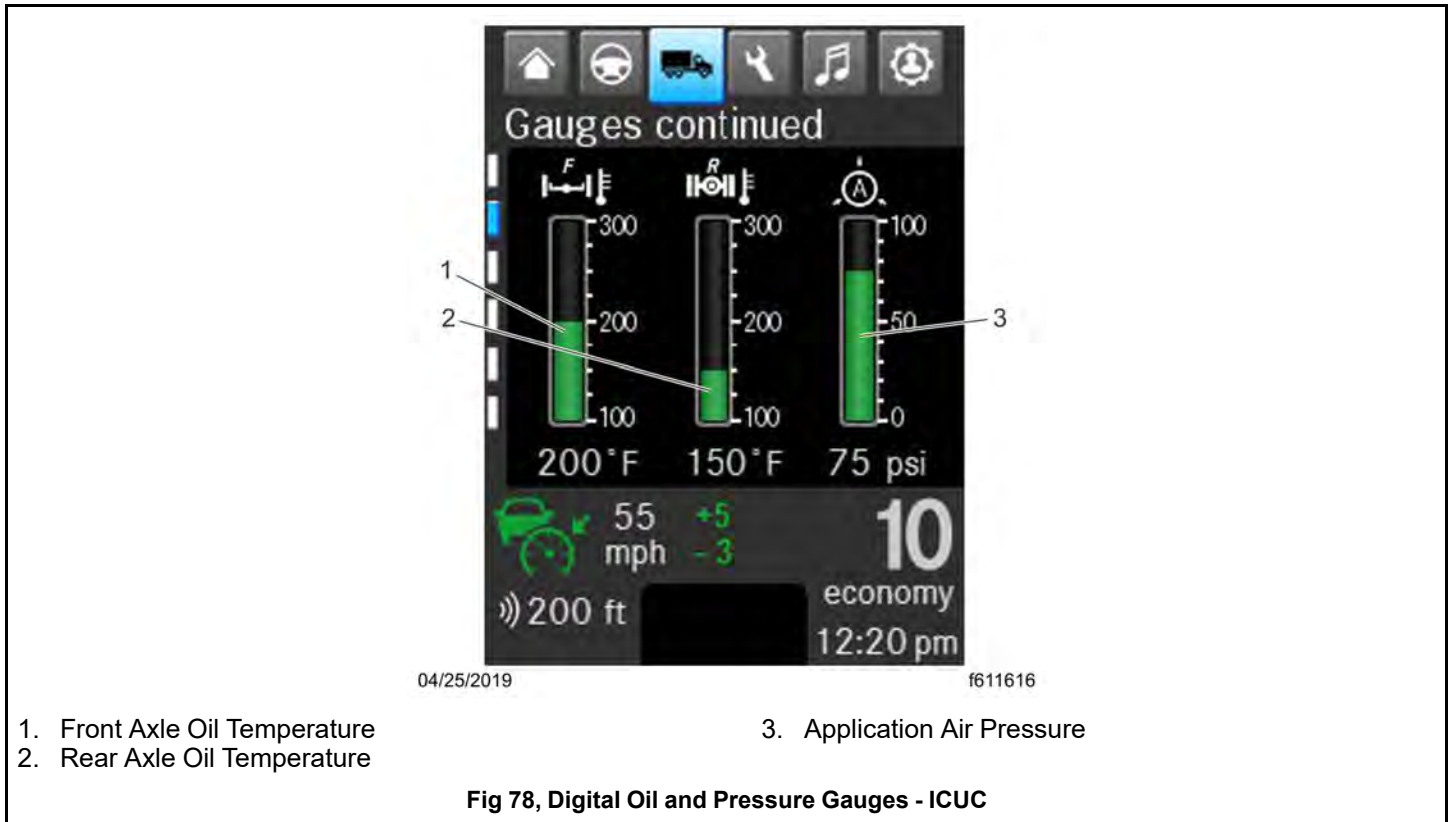

4.03.07 DEF and Diesel Particulate Filter Monitoring

See the **Emissions and Fuel Efficiency** chapter for details of Diesel Particulate Filter and DEF level monitoring.

4.03.08 Eco Driver Feedback

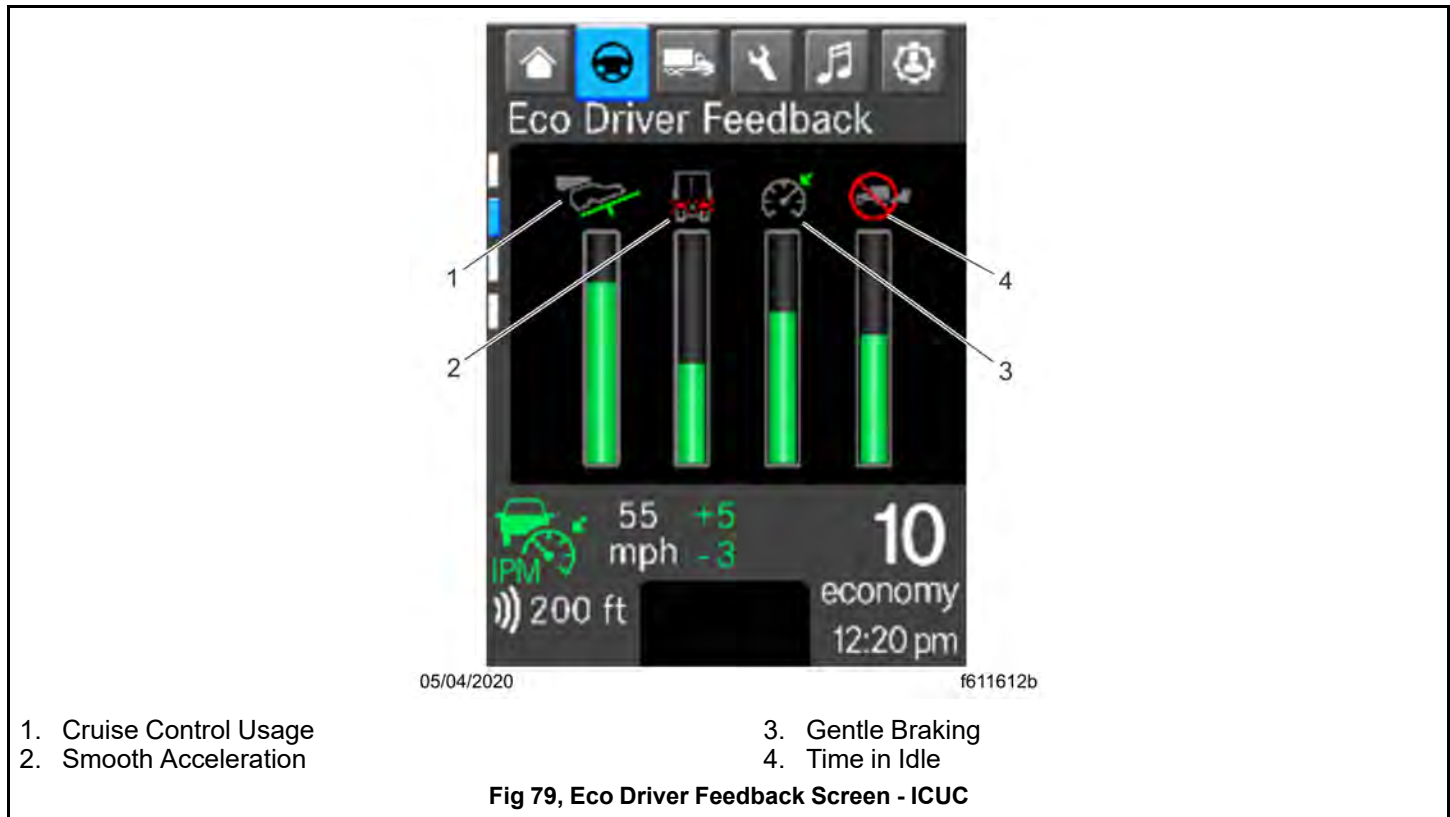

NOTE: The Eco Driver feature was discontinued in January 2020.

Eco Driver Feedback encourages a driver to make economical driving a habit with the goal of saving fuel and reducing wear.

Eco Driver Feedback gauges, located under the Drive Time Systems menu, display a driver's performance in four categories: gentle braking, smooth acceleration, cruise control usage, and time spent idling.

The ICU bar graphs display driver performance since the start of the vehicle. Performance values are newly calculated with each vehicle start. See Fig.79, [Eco Driver Feedback Screen - ICUC](#).

Examples of driving behavior that increases or decreases the amount of green in each column are as follows:

- Time in cruise control increases the Cruise Control Usage value.
- Failure to engage cruise control after the Use Cruise Control popup appears decreases the Cruise Control Usage value
- Pumping the accelerator pedal decreases the Smooth Acceleration value.
- Keeping the speed steady with cruise control off increases the Smooth Acceleration value.
- Sudden braking outside of an urban environment decreases the Gentle Braking value.
- No incidences of sudden breaking over time increases the Gentle Braking value.

4.03.09 Tire Pressure Monitoring System

The Tire Pressure Monitoring System (TPMS) screens display tire pressure, temperature, and sensor battery status. See Fig.80, [Vehicle Operations: TPMS Axle Tire Pressure, Temperature, and Sensor Status](#). Maintaining correct tire pressure increases fuel economy. Sustained high tire temperature can cause a tire to deteriorate, leading to tread separation and blowouts.

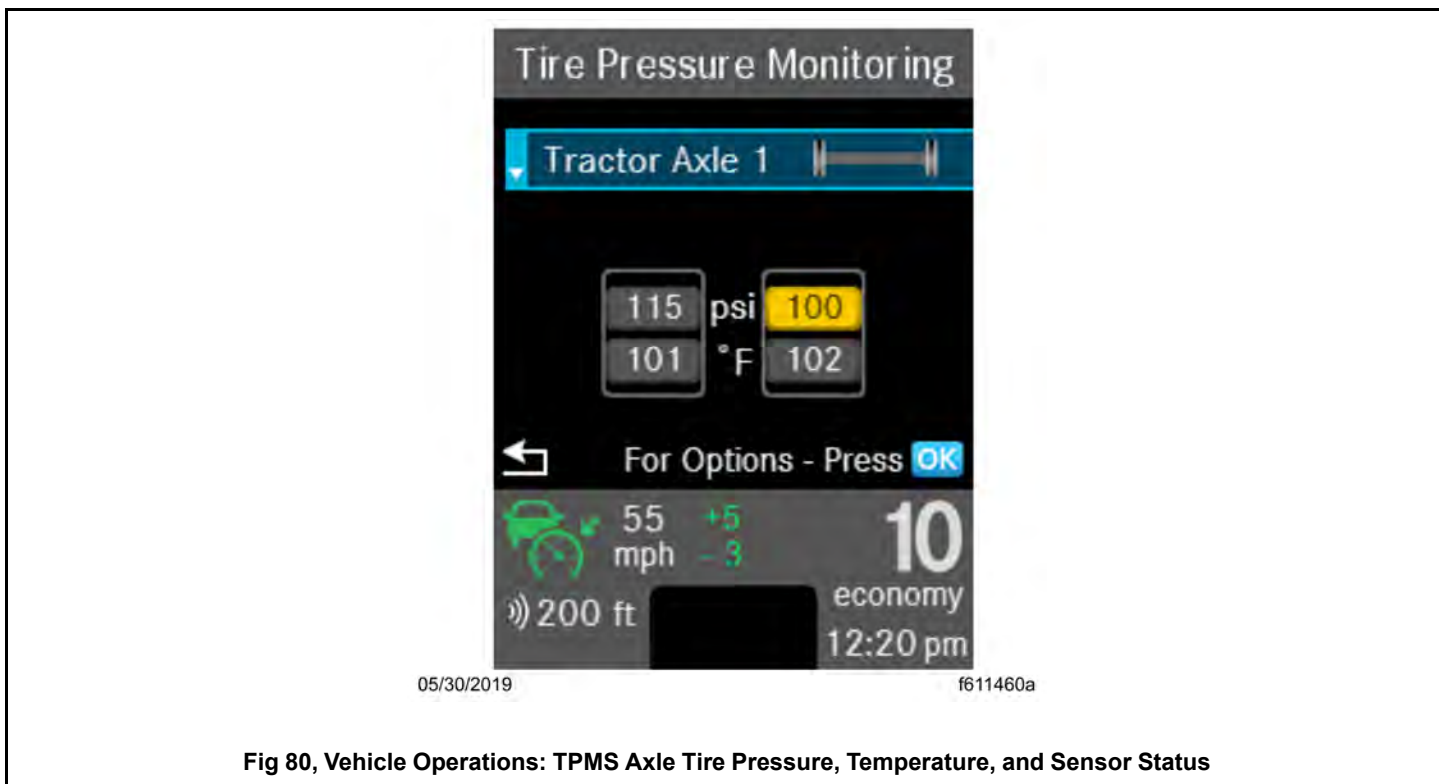

Fig 80, Vehicle Operations: TPMS Axle Tire Pressure, Temperature, and Sensor Status

Tire pressure can be displayed in psi or bar units. Temperature can be displayed in °F or °C. Units of measure are set under Settings. Sensor battery status is displayed as a bar chart inside the outline of a battery.

The TPMS will change the color of the tire on the ICUC screen if the tire pressure or temperature is either too high or too low. See Fig.80, [Vehicle Operations: TPMS Axle Tire Pressure, Temperature, and Sensor Status](#). It will also change the color of the sensor battery icon if the power levels are too low. Amber indicates a condition that may result in damage. Red indicates a condition that may pose a threat to the vehicle.

Tire pressure monitoring settings are part of the TPMS. Threshold temperatures and what triggers alerts can be set on this screen.

4.03.10 Other ICUC Gauges and Measurements

In addition to the two screens of gauges displayed under the Vehicle Operations menu described above, the ICUC driver display communicates a number of values related to vehicle operations. They are listed in alphabetical order below.

4.03.11 Alerts

The Alerts screen stores the current active alerts.

Alerts are color-coded to indicate severity. Red indicates a condition that may pose a threat to control of the vehicle. Amber indicates a condition that may result in damage to vehicle components or derating of engine power. Grey is used for notices.

4.03.12 Battery Voltage

The Home screen in the ICU displays the vehicle charging system voltage in the bottom left. By monitoring this number, the driver can stay aware of potential battery charging problems and have them fixed before the batteries discharge enough to create starting difficulties.

The Home screen will normally show approximately 13.7 to 14.1 volts when the engine is running. The voltage of a fully charged battery is 12.7 to 12.8 volts when the engine is off. Battery voltage under 12.0 volts is considered a low battery, and a completely discharged battery will produce only about 11.0 volts.

If the Home screen shows an undercharged or overcharged condition for an extended period, have the charging system and batteries checked at an authorized Freightliner service facility.

4.03.13 Diagnostics

The Diagnostics screen communicates fault codes and other diagnostic information about the vehicle.

Fault codes are color-coded to indicate the severity of the fault. Red indicates a condition that may pose a threat to control of the vehicle. Amber indicates a condition that may result in damage to vehicle components or derating of engine power. Grey indicates a condition that may affect fuel efficiency or vehicle handling.

4.03.14 Engine Maintenance

Shows the number of hours the engine has been operating.

4.03.15 Maintenance System

NOTE: The wrench icon is indicative of service, not of something that needs to be fixed.

Standard messaging is based on the number of miles (km) driven or time passed since the last service.

Predictive maintenance information is calculated based on these factors as well as engine and transmission load and oil temperature.

Currently, predictive maintenance information is given for engine oil, transmission oil, and axle oil changes. By taking driving conditions into account, predictive maintenance provides more accurate intervals for fluid changes.

Just before the service interval ends, a message that maintenance is due will appear. See Fig. 81, [Maintenance System Status - ICUC](#).



Fig 81, Maintenance System Status - ICUC

When the service interval is reached, a pop-up notice that maintenance is due will appear with every key cycle.

When the service interval is overdue, the color of the wrench icon on the maintenance screen will change from white to amber and the message will change to Maintenance Overdue. This cautionary pop-up will continue to appear with every key cycle.

Each service interval must be reset in the maintenance system when service is performed to provide for accurate future service intervals and to turn off pop-up messaging.

The reset button for maintenance system screens will not appear until the vehicle has been driven 6.2 miles and the engine has run for fifteen minutes.

Maintenance system information and service recommendations can also be viewed in the Detroit Connect portal. Information on the portal is updated every seven days.

4.03.16 Transmission Prognostics

The transmission prognostics screen is only available for Allison transmissions. It displays information on the transmission health status (oil filter status, oil level, and oil life). If transmission health falls below acceptable limits, a message will pop-up on the driver display.

NOTE: For a valid oil level measurement, the vehicle must be stopped on a level surface with the transmission in neutral (N).

4.03.17 Suspension Air Pressure

The ICUC may display four vehicle air suspension yellow caution alerts.

These include Suspension Lowered (see Fig.82,[Suspension Lowered Alert - ICUC](#)) and Suspension Raised (see Fig. 83,[Suspension Raised Alert - ICUC](#)) alerts indicating that the current rear suspension height is either below or above the normal ride height.



Fig 82, Suspension Lowered Alert - ICUC



Fig 83, Suspension Raised Alert - ICUC

ECAS Problem Detected alert (see Fig.84,[ECAS Problem Detected Alert- ICUC](#)) indicates the electronically controlled air suspension system has an active fault.

A flashing Load Transfer alert (see Fig.85,[Load Transfer Alert - ICUC](#)) indicates the ECAS system is applying the maximum available vehicle load on the drive axle up to the maximum allowable limit determined by the gross axle weight rating (GAWR). Load transfer mode automatically deactivates when the vehicle reaches 45 mph (72 kmh).

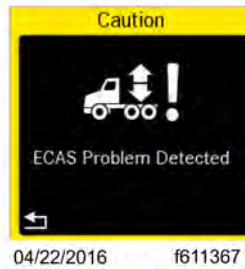

Fig 84, ECAS Problem Detected Alert- ICUC

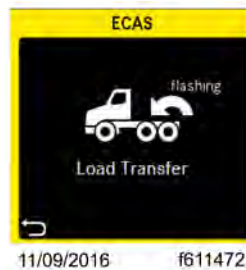

Fig 85, Load Transfer Alert - ICUC

4.03.18 ICUC Vehicle Operations: Vehicle Settings

The ICUC Vehicle Operations menu has a submenu called Vehicle Settings. Settings and controls for features installed on the vehicle can be found here. These may include:

- Cruise Control
- Transmission
- Attention Assist
- Engine Idle Adjust
- Optimized Idle

Many of these may also be accessible under the Quick Access Systems menu.

4.03.19 Cruise Control

Settings for cruise control include setting the overspeed and underspeed in mph or kph and setting the following distance in seconds. For full instructions on standard Cruise Control, see the chapter on **Driver Assistance Features**.

4.03.20 Transmission

The Transmission vehicle settings menu allows the driver to turn Creep Mode and eCoast on or off.

Creep mode is a DT12 Transmission feature that helps the driver move the vehicle at slow speeds by slipping the clutch to reduce torque to the wheels. It is designed to improve maneuverability in situations like parking, docking, and slow traffic.

To activate Creep mode for the first time within the current driving cycle, press the accelerator pedal to launch the vehicle, thereby fully engaging the clutch. Stopping the vehicle with the service brake will not cause the vehicle to exit Creep Mode. While in Creep Mode, a lower gear may be selected and the transmission can be upshifted or downshifted with the shifter stalk.

The eCoast feature is standard on DT12 engines. On a downslope the clutch will momentarily disengage so the vehicle maintains momentum while the engine idles. Engine rpms will drop to 600 in eCoast mode. Input from the driver will cause the vehicle to exit eCoast mode.

For a fuller coverage of Creep and eCoast mode see the chapter on **Automated and Automatic Transmissions**.

4.03.21 Attention Assist

The Attention Assist feature is intended to support the driver by calling attention to drowsy driving behavior and thereby encouraging rest.

The Attention Assist feature estimates the driver's attention level based on lane keeping and steering behavior and activity levels in using turn signals, retarder, and kick down operations.

When attention levels drop below a certain threshold, an audible warning will sound, a visual warning will appear on the ICU, and lane departure warnings will be activated if previously disabled.

4.03.22 Engine Idle Adjustment

This feature allows the increase or decrease of the base engine idle speed. Increasing the base engine idle might be necessary to generate enough power to operate accessories.

The following conditions must be met to the engine idle speed to be adjusted:

- Engine is running
- Vehicle is at a standstill
- Transmission is in neutral

4.03.23 Optimized Idle

Optimized Idle reduces idle time by automatically stopping and restarting the engine. Besides saving fuel, it helps keep the batteries charged while maintaining engine and cab temperature.

The following conditions must be met for the optimized idle to function:

- Vehicle in neutral gear
- Park brake set
- Hood latched
- Sleeper fan on

Optimized idle can be started with the engine running or the engine off.

With the key on, go to Vehicle Settings and scroll down to Optimized Idle. Press OK.

To enable optimized idle, press okay again. A screen will appear saying the default battery mode is on and interior comfort mode is off.

If you want to optimize the environment of the sleeper section, turn on comfort mode. Press the right hand arrow in the left hand switch pod to turn interior comfort mode on and then press OK.

The vehicle will go into standby mode, an under hood alarm will briefly sound, and the engine will crank and achieve 900 rpm. The ICUC screen will then state that it is in interior comfort mode and the engine and air conditioning/fan will run until it achieves the temperature requested by the driver. The engine will then shut down.

Optimized idle can be shut off by ICUC controls or pressing the brake. If the sleeper fan is turned off, optimized idle will not shut down but the engine will.

For a fuller description of Optimized Idle, see the chapter on **Optional Engine Systems**.

4.04 Infotainment: ICUC

4.04.01 Safety Information

**WARNING:**

There is a risk of distraction from operating integrated communication equipment while the vehicle is in motion.

A driver can be distracted from the traffic situation if operating communication equipment integrated in the vehicle when driving, possibly causing loss of control of the vehicle.

Only operate this equipment when the road and traffic situation permits, otherwise stop and operate the equipment with the vehicle stationary.

The driver must observe the legal requirements of the country the vehicle is driving through when operating the system.

Wearing polarized sunglasses may impair or limit your ability to read the display.

4.04.02 Navigation and Infotainment Reception

Features of both the navigation and infotainment system depend on cellular and satellite reception. In certain situations, such as driving through tunnels, mountains, or parked in multistory parking lots, reception may be impaired due to interference or there may be no reception at all.

4.04.03 General ICUC Infotainment Information

The ICUC infotainment system options consist of:

- AM/FM Radio
- Satellite Radio: SiriusXM®
- Weather Radio
- CD player
- USB & AUX input
- Smart phone Integration

ICUC Infotainment Screens

Use 'Menu Up' and 'Menu Down' to navigate the infotainment screens:

1. Audio (AM/FM/Weather, SiriusXM, CD, USB, AUX). See Fig. 86, [Infotainment: Radio](#).



Fig 86, Infotainment: Radio

- 2. Telephone, showing signal strength, battery level, phone number, and active call length. See Fig. 87, [Infotainment: Active Call](#).



Fig 87, Infotainment: Active Call

4.04.04 ICUC Audio Features

Radio and Other Audio Sources

NOTE: It is a standard safety feature for the radio to mute during safety related events; starting in June 2021 Pana-Pacific/Aptiv radios installed in Freightliner vehicles will automatically mute when the vehicle is in reverse gear.



Fig 88, Infotainment: Radio

Radio stations, presets, and other audio sources can be accessed under Audio.

1. Select the single bar note icon to open the infotainment menu. The last infotainment menu accessed will open.
2. If not on the Audio screen, press the Up arrow in the left-hand steering wheel switch pod to move to this screen.
3. Press OK on the left-hand steering wheel switch pod to access Audio Settings.
4. Use the Right and Left arrows to navigate from one audio source to another from radio to USB for example.
5. Use the Up and Down arrows to navigate through an audio options list of choices. Choices can vary depending on the number of audio sources available and saved presets.
6. Press OK on the left-hand steering wheel switch pod to select an audio source. The audio source is selected.
7. Press the Back button to return to the main Audio screen.

Weather Radio (WX)

Weather Radio is an option under Audio.

Weather radio channels WX1 through WX7, corresponding to frequencies 162.400 MHz through 162.550 MHz, are the standard weather radio channels used by NOAA Weather Radio in the United States, Weatheradio Canada/Radiométéo Canada in Canada, and SARMEX in Mexico. Each system consists of a nationwide network of radio stations broadcasting official weather warnings, watches, advisories, forecasts and other non-weather related hazard information including news on natural disasters (earthquakes, avalanches, floods), environmental hazards (oil spills, chemical releases), and public safety messages (AMBER alerts, network outages). All services operate 24 hours a day, 7 days a week.

The average range for reception from a transmitter is approximately 40 miles (60 km). The National Weather Service operates more than 1000 transmitters.

Adjusting the Volume

Volume can be adjusted up using the VOL+ and down using the VOL switches in the left-hand steering wheel switch pod.

4.04.05 ICUC Telephone Features

General Description, Telephone

Telephone is the second screen under infotainment. The main telephone screen shows the connected phones current signal and battery strength. If a call is in progress it will show the phone number and call length.

Telephone Settings



Fig 89, Infotainment: Active Call

Telephone settings displays the phone's call history, contacts, and any contact presets.

1. Select the single bar note icon to open the infotainment menu. The last infotainment menu accessed will open.
2. If not on the Telephone Screen, use the Down arrow in the left-hand steering wheel switch pod to move to this screen.
3. When on the Telephone screen, select OK on the left-hand steering wheel switch pod to access Telephone Settings.
4. Use the Right and Left arrows to navigate from one telephone setting to another from contacts to missed calls for example.
5. Use the Up and Down arrows in the left-hand steering wheel switch pod to navigate through the current Telephone Settings list of choices.
6. Press OK on the left-hand steering wheel switch pod to choose an option.
7. Press the Back left-hand steering wheel switch pod to return to the main screen.

4.05 Analog Instruments

4.05.01 Air Intake Restriction Gauge

Physical instruments are listed here in alphabetical order. Some are optional and therefore not found in every vehicle. Digital instruments and gauges are described in their ICU section.

The air intake restriction gauge indicates the vacuum on the engine side of the air cleaner. On standard installations, it is mounted on the air intake duct in the engine compartment, and has a go/no-go restriction indicator without graduations. See Fig. 90, [Manual-Reset Air Restriction Indicator, Go/No-Go](#). As an option, a graduated indicator (see Fig. 91, [Air Intake Restriction Indicator, Graduated](#)) on the air intake duct or, for easier viewing, a dash-mounted restriction gauge may be installed.



Fig 90, Manual-Reset Air Restriction Indicator, Go/No-Go

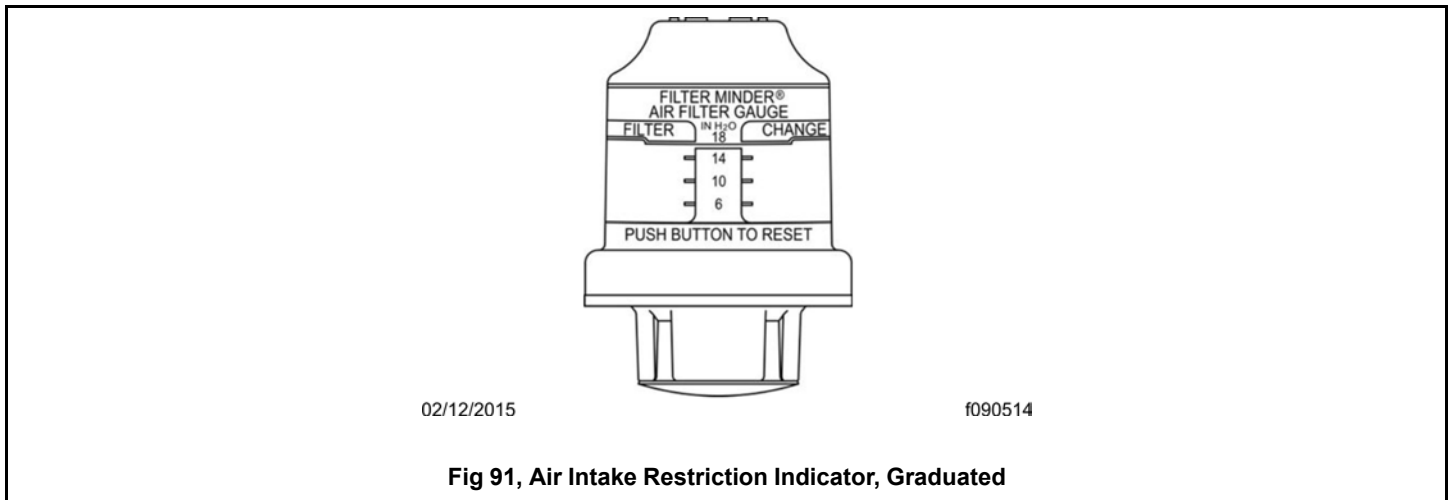

Fig 91, Air Intake Restriction Indicator, Graduated

Air intake restriction vacuum is measured in Inches of Water (in H₂O). For vehicles equipped with a graduated indicator or a restriction gauge on the dash, check the gauge with the engine off. If the yellow signal stays locked in the red zone once the engine is shut down, or is at or above the values, shown in Table 3, [Air Intake Maximum Restriction Values \(in H₂O\)](#), the air cleaner element needs to be replaced.

| Engine Make | GHG14, GHG17, and GHG21 Engines |
|-------------|---------------------------------|
| Cummins | 25 |
| Detroit | 18 |

Table 3, Air Intake Maximum Restriction Values (in H₂O)

NOTE: Rain or snow can wet the filter and cause a temporary high reading.

4.05.02 Application Air Pressure Gauge

Physical instruments are listed here in alphabetical order. Some are optional and therefore not found in every vehicle. Digital instruments and gauges are described in their ICU section.

An application air pressure gauge (see Fig.92,[Application Air Pressure Gauge](#)) registers the air pressure being used to apply the brakes, and should be used for reference only. The gauge will not register air pressure until the foot brake pedal is depressed or the trailer hand brake is applied.



4.05.03 Coolant Temperature Gauge

Physical instruments are listed here in alphabetical order. Some are optional and therefore not found in every vehicle. Digital instruments and gauges are described in their ICU section.



NOTICE:

A sudden increase in coolant temperature may indicate engine or cooling system failure. Bring the vehicle to a safe stop and investigate the cause to prevent further damage. Do not operate the engine until the cause has been determined and corrected.

During normal engine operation, the coolant temperature gauge should read 175 to 195°F (79 to 91°C). If the temperature remains below 160°F (71°C), inspect the cooling system to determine the cause. See Fig. [93, Analog Coolant Temperature Gauge - ICUC](#).

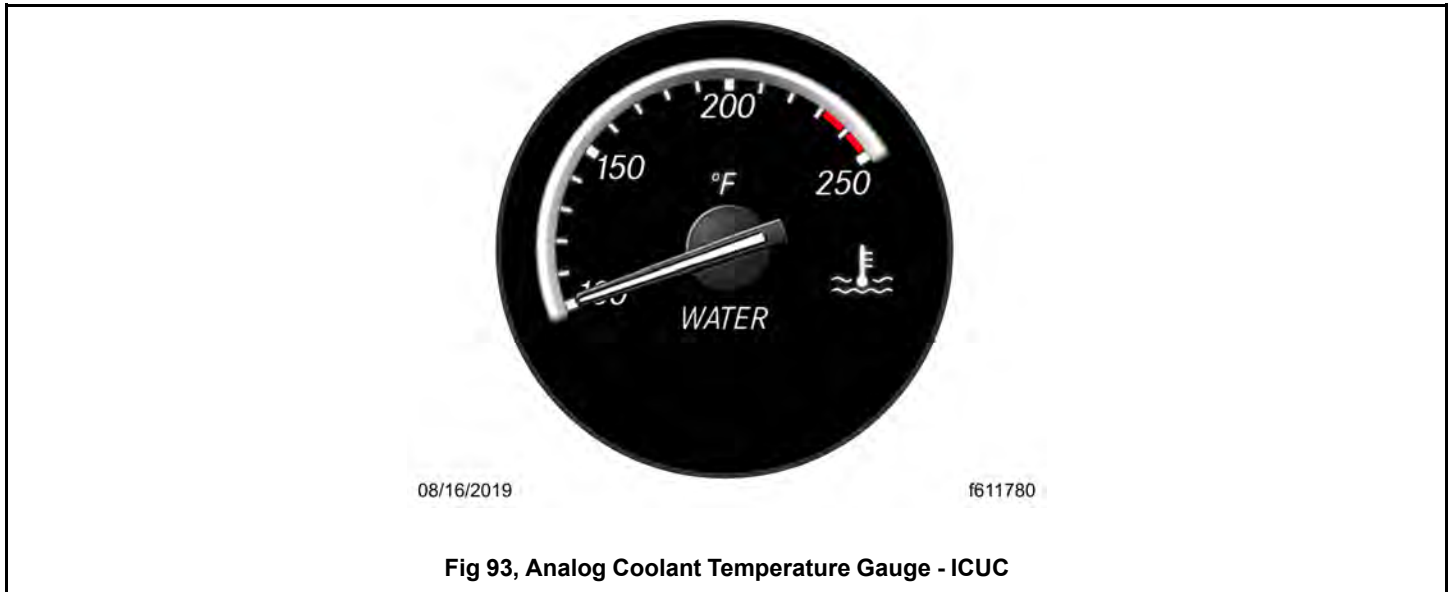

Fig 93, Analog Coolant Temperature Gauge - ICUC

For Detroit engines, if coolant temperature rises above the maximum temperature listed in Table 4, [Maximum Coolant Temperature](#), the CHECK engine lamp will illuminate. If the condition does not improve, the STOP engine lamp will also illuminate and an audible warning will sound. The engine will then derate or shut down, depending on the type of engine protection system installed.

For Cummins engines, the fan will come on when the coolant temperature reaches 215°F (101°C) and the check engine light will illuminate when coolant temperature rises above the maximum temperature listed in Table 4, [Maximum Coolant Temperature](#).

| Engine Make | Temperature: °F (°C) |
|------------------------|----------------------|
| Cummins | 221 (105) |
| Detroit DD13/DD15/DD16 | 234 (112) |

Table 4, Maximum Coolant Temperature

4.05.04 Drive Axle Oil Temperature Gauges

Physical instruments are listed here in alphabetical order. Some are optional and therefore not found in every vehicle. Digital instruments and gauges are described in their ICU section.



NOTICE:

A sudden increase in oil temperature that is not caused by a load increase may indicate mechanical failure. Bring the vehicle to a safe stop and investigate the cause to prevent further damage. Do not operate the vehicle until the cause has been determined and corrected.

During normal operation, the drive axle oil temperature gauges should read as follows:

- 160 to 220°F (71 to 104°C) for Detroit® Classic Model 2, 4, and 6 axles.
- 160 to 329°F (71 to 165°C) for Detroit® New Final Drive (NFD) axles.
- 160 to 329°F (71 to 165°C) for Detroit® Adaptive Tandem 6 X 4 axles.

- 160 to 275°F (71 to 135°C) for Meritor drive axles.
- 180 to 200°F (82 to 93°C) for Dana Spicer® drive axles.

Under heavy loads, such as when climbing steep grades, temperatures that exceed the normal oil temperature range for a short period are not unusual. If the temperature returns to normal when the load decreases, there is no problem. See Fig. 94, [Drive Axle Oil Temperature Gauge \(rear drive axle gauge shown\)](#).



4.05.05 Engine Oil Pressure Gauge

Physical instruments are listed here in alphabetical order. Some are optional and therefore not found in every vehicle. Digital instruments and gauges are described in their ICU section.



NOTICE:

A sudden decrease or absence of oil pressure may indicate mechanical failure. Bring the vehicle to a safe stop and investigate the cause to prevent further damage. Do not operate the engine until the cause has been determined and corrected.

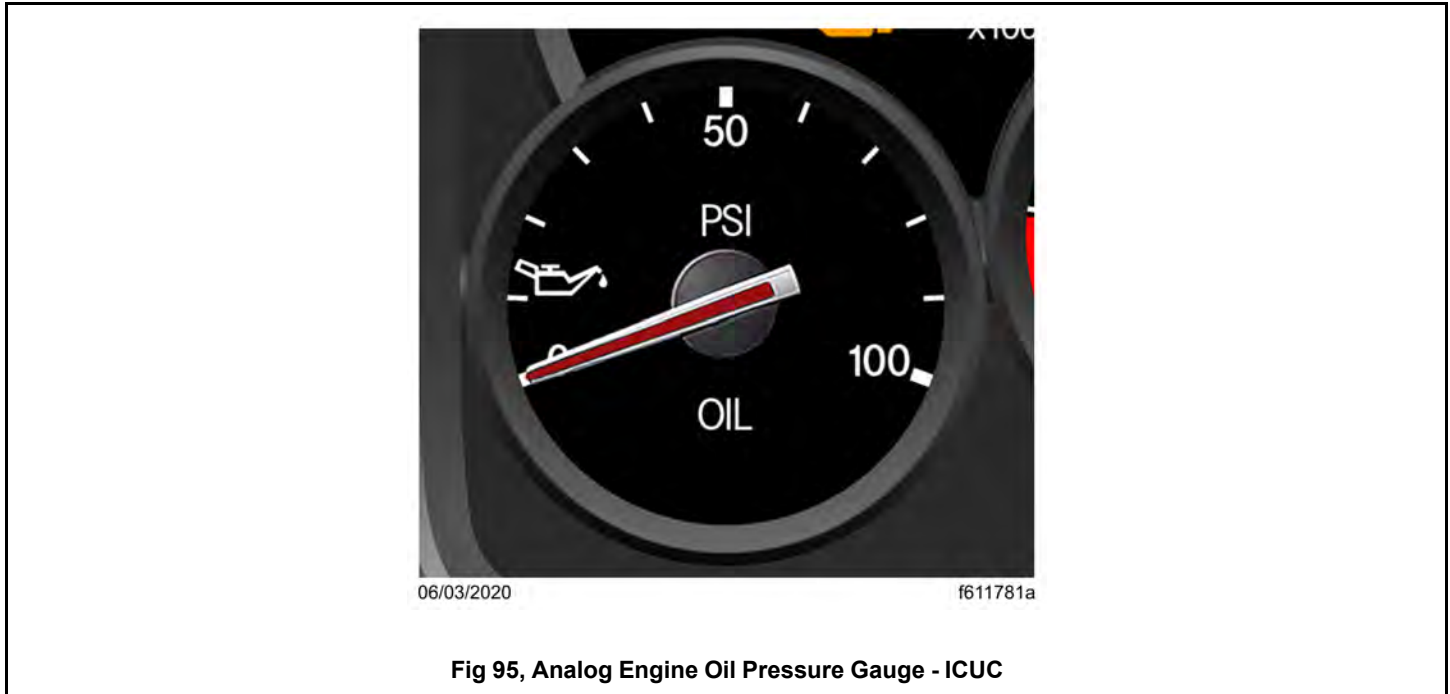

Fig 95, Analog Engine Oil Pressure Gauge - ICUC

Except for Detroit Gen 5 DD13 and DD15 engines, the engine oil pressure gauge displays the current engine oil pressure. If engine oil pressure falls below the minimum levels shown in Table 5, [Minimum Engine Oil Pressure](#), the CHECK engine lamp will illuminate. If the condition does not improve, the STOP engine lamp will also illuminate and an audible warning will sound. The engine will then derate or shut down, depending on the type of engine protection system installed.

NOTE: Oil pressures are given with the engine at operating temperature. With the engine cold, oil pressure may be higher. Individual engines may vary from the listed pressures; observe and record pressures when the engine is new to create a guide for checking engine condition.

| Engine Model | At Idle Speed: psi (kPa) ¹ | At Rated RPM: psi (kPa) ² |
|---------------------------|---------------------------------------|--------------------------------------|
| Cummins | 15 (103) | 35 (241) |
| Detroit Gen 5 DD13/DD15 | 50 (344) | 50 (344) |
| All Other Detroit Engines | 14 (97) | 55 (350) |

1. Standard idle speed is 600 RPM. Actual engine idle speed can vary ±100 RPM depending on transmission type.
2. All Detroit heavy-duty engines are rated at 1800 RPM.

Table 5, Minimum Engine Oil Pressure

For Detroit Gen 5 DD13 and DD15 engines, the gauge will read a steady 50 psi (344 kPa) with normal engine oil pressure. If the engine oil pressure is low, the CHECK lamp will illuminate and the oil pressure gauge will read 25 psi (172 kPa). If the condition does not improve, the STOP lamp will illuminate, an audible warning will sound, and the gauge will read 0 psi. The engine will then derate or shut down, depending on the type of engine protection system installed.

4.05.06 Engine Oil Temperature Gauge

Physical instruments are listed here in alphabetical order. Some are optional and therefore not found in every vehicle. Digital instruments and gauges are described in their ICU section.

**NOTICE:**

A sudden increase in oil temperature that is not caused by a load increase may indicate mechanical failure. Bring the vehicle to a safe stop and investigate the cause to prevent further damage. Do not operate the engine until the cause has been determined and corrected.

During normal operation, the optional engine oil temperature gauge should read in the following temperature range:

- 200 to 260°F (93 to 126°C) for Detroit and Cummins engines

Under heavy loads, such as when climbing steep grades, temperatures that exceed the normal oil temperature range for a short period are not unusual. If the temperature returns to normal when the load decreases, there is no problem. See Fig. 96, [Engine Oil Temperature Gauge](#).

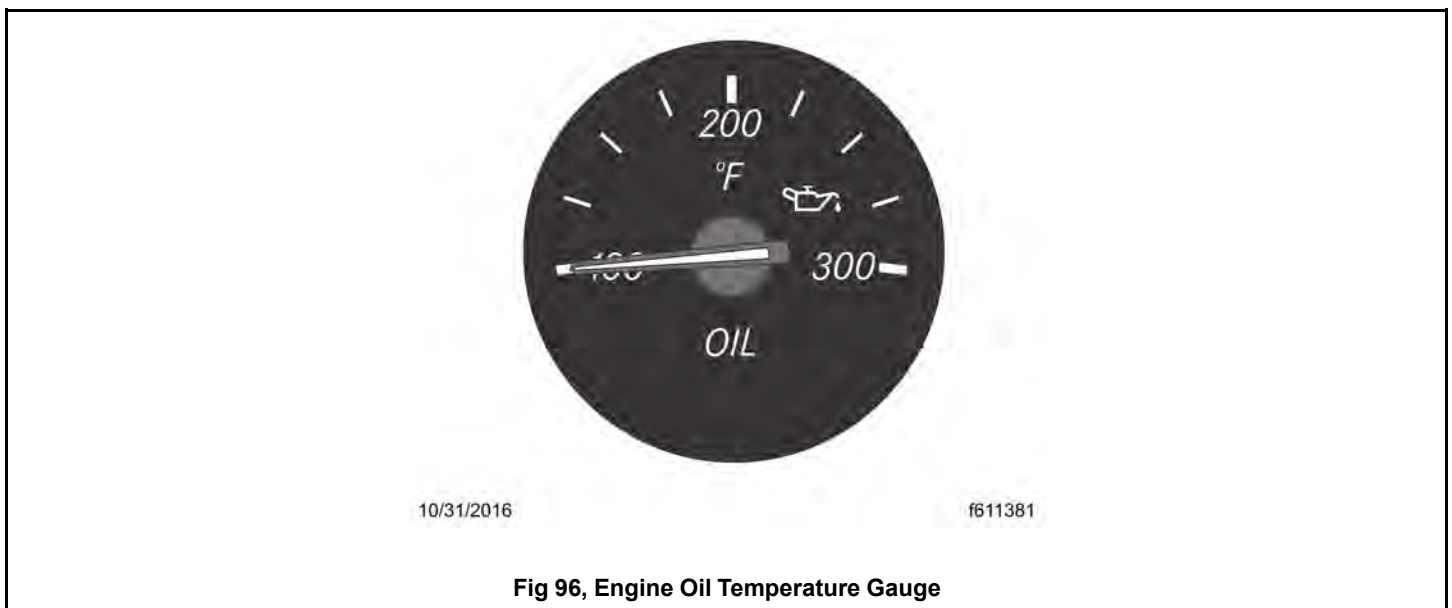

4.05.07 Fuel/Diesel Exhaust Fluid (DEF) Gauge

Physical instruments are listed here in alphabetical order. Some are optional and therefore not found in every vehicle. Digital instruments and gauges are described in their ICU section.

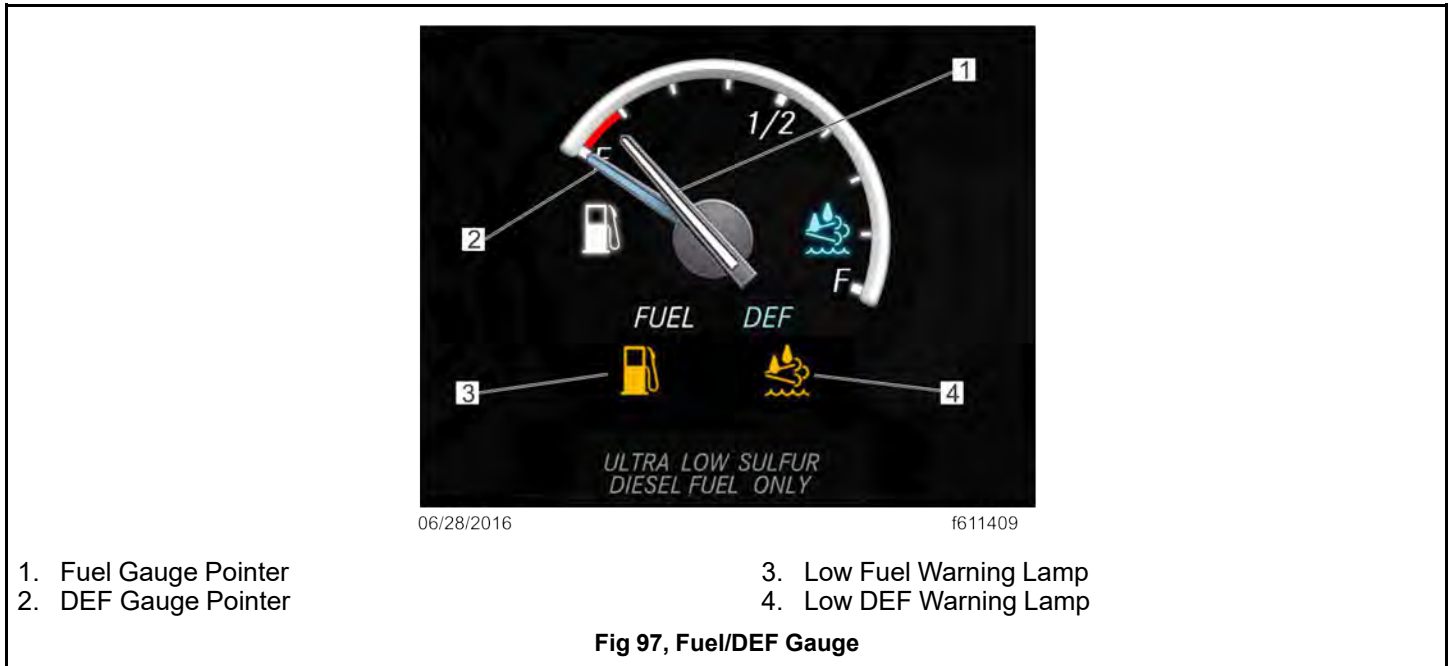

The fuel and DEF levels can be measured in a dual purpose fuel/DEF level gauge. See Fig. 97, [Fuel/DEF Gauge](#).

The diesel fuel and DEF levels are indicated on the gauge. A low fuel warning lamp illuminates amber when the diesel fuel level registers 1/8th of capacity. The low DEF warning lamp illuminates amber when the DEF level reaches 10% of capacity. See [15.01 Greenhouse Gas Emissions and Fuel Consumption Standards](#) in **Emissions and Fuel Efficiency** for details of the DEF gauge functions.

4.05.08 Primary and Secondary Air Pressure Gauges

Physical instruments are listed here in alphabetical order. Some are optional and therefore not found in every vehicle. Digital instruments and gauges are described in their ICU section.



WARNING:

If air pressure falls below minimum pressure, the braking ability of the vehicle will be limited. Slow the vehicle down and bring it to a gradual stop. Do not attempt to move the vehicle until air pressure has risen above the minimum level. Moving a vehicle without adequate braking power could cause an accident resulting in property damage, personal injury, or death.

Air pressure gauges register the pressure in the primary and secondary air systems. See Fig. 98, [Analog Combined Application Air Pressure Gauge - ICUC](#). Normal pressure, with the engine running, is 100 to 120 psi (689 to 827 kPa) in both systems.



08/16/2019

f611779

Fig 98, Analog Combined Application Air Pressure Gauge - ICUC

NOTE: The low-air warning buzzer only works when the park brake is released. The low-air warning buzzer is silenced when the park brake is set.

If air pressure drops below approximately 70 psi (483 kPa), a warning light illuminates and the driver display shows a warning. A low-air warning buzzer also sounds if the park brake is not set.

NOTE: If the pressure in both air systems drops below 70 psi, the parking brakes will drag or apply.

4.05.09 Speedometer

Physical instruments are listed here in alphabetical order. Some are optional and therefore not found in every vehicle. Digital instruments and gauges are described in their ICU section.

Two physical speedometer options are available. The U.S. version of the speedometer (see Fig. 99, [Analog Speedometer - ICUC](#)) registers speed in both miles per hour (mph) and kilometers per hour (km/h), with mph in larger numbers. The metric version of the speedometer face reverses this arrangement, with km/h in larger numbers.



08/16/2019

f611782

Fig 99, Analog Speedometer - ICUC

4.05.10 Suspension Air Pressure Gauge

Physical instruments are listed here in alphabetical order. Some are optional and therefore not found in every vehicle. Digital instruments and gauges are described in their ICU section.

A suspension air pressure gauge (see Fig. 100, [Suspension Air Pressure Gauge](#)) registers the air pressure applied to the vehicle air suspension.



4.05.11 Tachometer

Physical instruments are listed here in alphabetical order. Some are optional and therefore not found in every vehicle. Digital instruments and gauges are described in their ICU section.

The tachometer or rev counter indicates engine speed in revolutions per minute (rpm) and serves as a guide for shifting the transmission and keeping the engine in the appropriate rpm range. The tachometer has only one unit of measurement, 0-2500 rpm. For low idle and rated rpm, consult your vehicle's engine identification plate. See Fig. 101, [Analog Tachometer - ICUC](#).



01/02/2020

f611783

Fig 101, Analog Tachometer - ICUC

4.05.12 Transmission Fluid Temperature Gauge

Physical instruments are listed here in alphabetical order. Some are optional and therefore not found in every vehicle. Digital instruments and gauges are described in their ICU section.

The transmission fluid temperature gauge, (see Fig.102, [Transmission Fluid Temperature Gauge](#)) measures the transmission lubricant operating temperature. Temperatures vary by application, but the transmission fluid temperature gauge reading should not exceed 250°F (121°C).



10/31/2016

f611383

Fig 102, Transmission Fluid Temperature Gauge

**NOTICE:**

A sudden increase in transmission fluid temperature that is not caused by a load increase may indicate mechanical failure. Bring the vehicle to a safe stop and investigate the cause to prevent further damage. Do not operate the vehicle until the cause has been determined and corrected.

Under heavy loads, such as when climbing steep grades, temperatures that exceed the normal oil temperature range for a short period are not unusual. If the temperature returns to normal when the load decreases, there is no problem.

4.05.13 Turbocharger Boost Pressure Gauge

Physical instruments are listed here in alphabetical order. Some are optional and therefore not found in every vehicle. Digital instruments and gauges are described in their ICU section.

A turbocharger boost pressure gauge (see Fig.103, [Turbocharger Boost Pressure Gauge](#)) indicates the pressure in the intake manifold, in excess of atmospheric pressure, being created by the turbocharger.

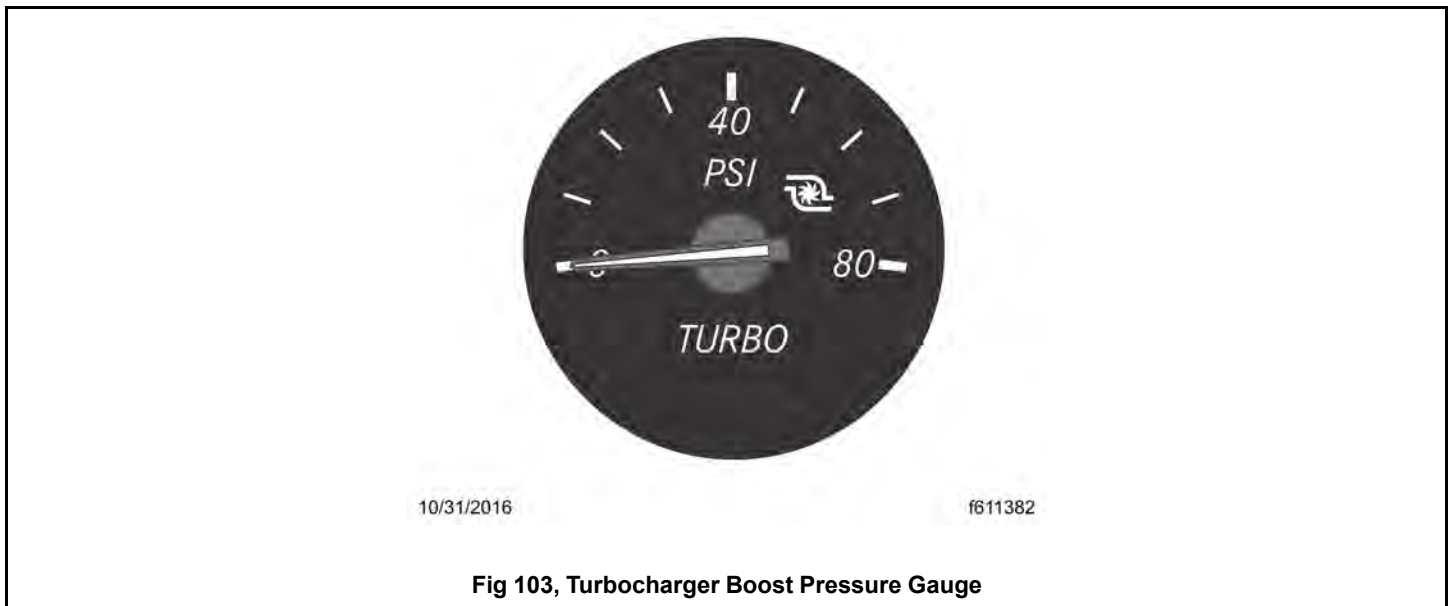

Fig 103, Turbocharger Boost Pressure Gauge

4.05.14 Voltmeter

Physical instruments are listed here in alphabetical order. Some are optional and therefore not found in every vehicle. Digital instruments and gauges are described in their ICU section.

The voltmeter indicates the vehicle charging system voltage when the engine is running and the battery voltage when the engine is off. By monitoring the voltmeter, the driver can stay aware of potential battery charging problems and have them fixed before the batteries discharge enough to create starting difficulties.

The voltmeter will normally show approximately 13.7 to 14.1 volts when the engine is running. The voltage of a fully charged battery is 12.7 to 12.8 volts when the engine is off. Battery voltage under 12.0 volts is considered a low battery, and a completely discharged battery will produce only about 11.0 volts.

If the voltmeter shows an undercharged or overcharged condition for an extended period, have the charging system and batteries checked at an authorized Freightliner service facility.

On a vehicle equipped with a battery isolator system, the voltmeter measures the average voltage of all the batteries when the engine is running. When the engine is off, the voltmeter shows only the isolated battery voltage and does not indicate the voltage of the engine-starting batteries.

4.06 Instrumentation Control Unit: ICC5

4.06.01 General Description, ICC5

The instrumentation control unit (ICU) provides the driver with engine and vehicle information. A New Cascadia vehicle can be equipped with either an ICUC or ICC5. See Fig. 104, [ICC5 Dual Display Screens and USB2 ports](#) for a typical ICC5 layout.

This section provides general system and operating instructions for ICC5 components. Following sections provide more detailed information.

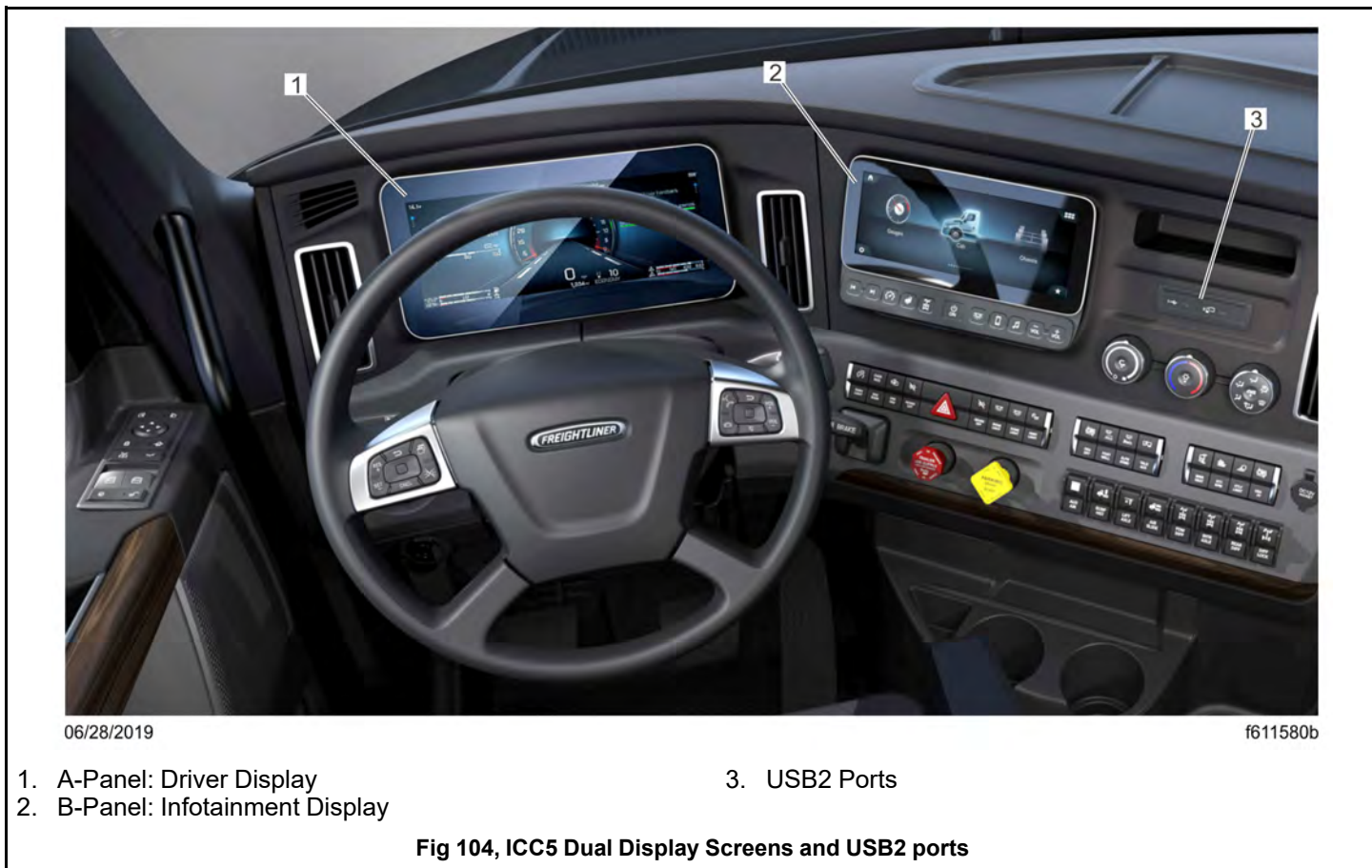

ICC5

The Instrument Cluster Connect 5, or ICC5, has a driver display screen, an infotainment touch screen, a multimedia connection unit with two USB2 ports, optical finger navigation control (OFN) buttons on the steering wheel, and visual and audible warning systems.

The driver display, or A-panel, provides the driver with information about the vehicle status and vehicle systems. The infotainment display, or B-panel, provides access to phone, radio, navigation, and other controls. See "Driver Display: ICC5" in this chapter for details on the A-panel display features. See "Infotainment: ICC5" in this chapter for details on the B-panel display and multimedia connection unit.

4.06.02 Ignition Sequence

When the ignition is turned on, the ICU runs a self-check. Observing the ignition sequence is a good way to ensure the ICU is functioning properly.

IMPORTANT: Do not crank the engine until the ICU self-check is complete.

ICC5

NOTE: There is no Lane Departure Warning audible self-test.

When the ignition is turned on, the following actions should occur in the ICC5:

- The logos for the engine and transmission display on the infotainment screen.
- If installed, an Active Brake Assist (ABA) popup disclaimer appears on the driver display screen.
- If ignition status is set to Adaptive Cruise Control (ACC), the tripmeter and odometer values are shown on the driver display screen.
- If the ignition is set to ON, all ICC5 screens and options are available.

IMPORTANT: If any red or amber warnings do not go out after the self-check completes, take the action outlined in the **Warnings, Indicators, and Messages** section in this chapter, then take the vehicle to an authorized Freightliner service facility as soon as possible.

4.06.03 ICC5 Screen Navigation

NOTE: The brightness of the ICC5 display screens can be adjusted in Settings.

The ICC5 is equipped with two screens. The driver display screen in the dashboard in front of the driver and the infotainment screen.

The driver display screen provides basic vehicle and environmental information. Battery voltage, outside ambient air temperature, current time, and current compass direction are displayed across the top of the screen. Information such as fuel gauge, current speed, gear, odometer reading, and primary and secondary air pressure gauges display on the bottom of the screen. Telltales are displayed at both the top and bottom of the screen.

The driver display screen provides information in two different modes: a base screen layout and a pilot screen layout.

The base screen consists of a digital tachometer/speedometer in the center of the screen. See Fig. 105, [Driver Display Base Screen - ICC5](#).

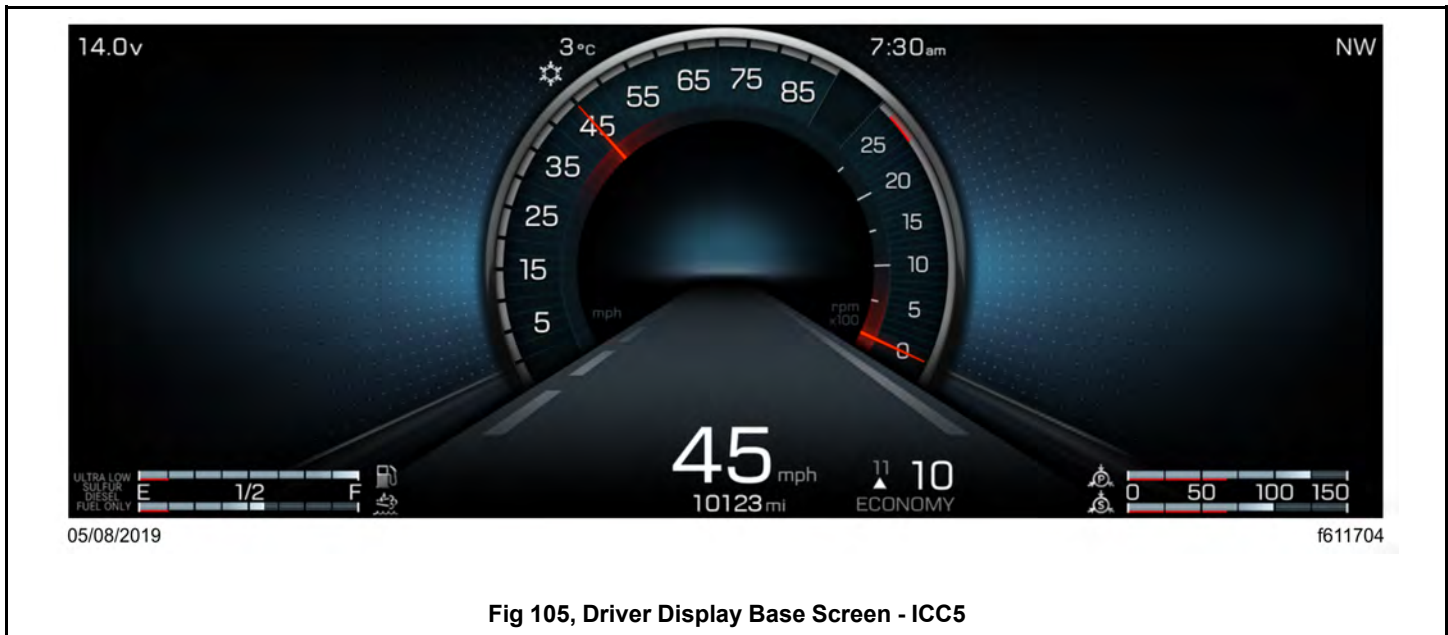

Fig 105, Driver Display Base Screen - ICC5

The pilot screen moves the speedometer and tachometer to the bottom of the screen to provide driving assistance information in the screen's center. See Fig. 106, [Driver Display Pilot Screen - ICC5](#)



Fig 106, Driver Display Pilot Screen - ICC5

The infotainment screen is a touch screen and displays the standard gauges as well as information about the cab and chassis. It also serves as the navigation systems screen, provides access to lighting and radio controls, and manages the integration of phone, smart phone and media sources. Each corner of the ICC5 infotainment display is a quick access icon for commonly used features. For an overview of menu category icons on the infotainment screen as well as infotainment quick access icons, see Fig.107, [Infotainment Menu Options, Icons, Status Line - ICC5](#).

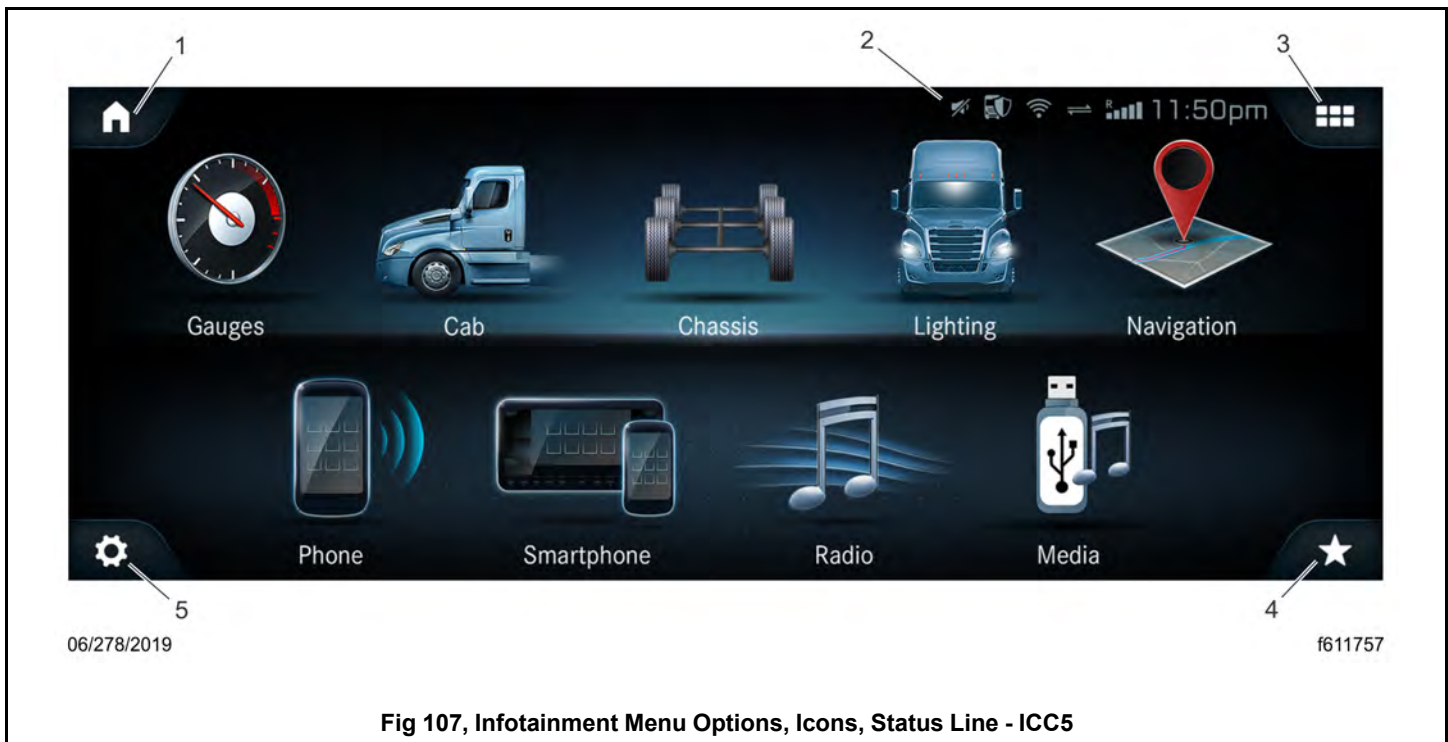

Fig 107, Infotainment Menu Options, Icons, Status Line - ICC5

NOTE: Screens may vary depending on vehicle options. Some screens are accessible only when the vehicle is parked.

4.06.04 ICC5 Steering Wheel Buttons

To navigate features and screens, use the Optical Finger Navigation Control (OFN) buttons on the steering wheel. See Fig. 108, [Steering-Wheel-Mounted Optical Finger Navigation Control \(OFN\) buttons - ICC5](#).

The buttons in the left-hand pod control the driver display features. The buttons in the right-hand pod provide access to infotainment features and menus.



10/25/2018

f611531

A. Menu Buttons The left Menu button accesses the driver display. The right Menu button accesses the infotainment screen.

- 1. Cruise Accelerate/Resume
- 2. Back Button
- 3. Quick Access System Settings
- 4. Marker Interrupt
- 5. Cruise Cancel

- 6. Cruise Decelerate/Set
- 7. Phone Pick-Up
- 8. Back Button
- 9. Volume Increment Up
- 10. Volume Increment Down
- 11. Mute Button
- 12. Phone Hang-Up/Reject
- 13. Not available in all markets.

Fig 108, Steering-Wheel-Mounted Optical Finger Navigation Control (OFN) buttons - ICC5

4.06.05 ICC5 Touch Screen Operation

IMPORTANT: All keyboard entries are locked when the parking brake is disengaged. Other touch screen options still function.

Tapping

Tap the touch screen to:

- Select a menu item, icon, or entry
- Enter characters with keyboard by tapping on a character buttons.

Single-Finger Swipe

Use a single-finger swipe to:

- Navigate in menus: swipe up, down, left or right.
- Scroll through screens.
- Select a menu item, icon, or entry.

Touching, Holding and Moving

Touch, hold, and move the finger to:

- Select the value on a slider control.

4.06.06 Time and Date

NOTE: Time and date are set automatically when the vehicle is equipped with a tachograph. When a vehicle is equipped with a tachograph only the time zone can be changed.

ICC5 time and alarm clock settings can be found under the Settings menu. See the appropriate Driver Display section for details.

The correct time and date is required for the following ICC5 functions to work:

- Alarm clock
- Navigation guidance with time-dependent traffic routing
- Calculation of the expected time of arrival
- Maintenance
- Prognostics

4.06.07 Software Updates

A software update consists of three steps:

1. Downloading the software.
2. Installing the software.
3. Activating the software by restarting the system.

A popup message and a blue folder will appear in one of the dynamic telltale locations on the driver display when an update is available. In addition the software update option in the diagnostics menu will be active.

The vehicle must be in neutral gear, the parking brake set, and the engine off before a software update can start. Once started, a software update cannot be cancelled.

During the software update process, progress messages will be provided.

If a software update is interrupted, the system will ask if you want to restart the process or inform you that the vehicle cannot be driven until the update is complete. If a software update fails, the system will attempt to revert to the previous version. A notification will appear when a software update has been successfully installed.

Failure to install software updates may make data less secure and/or mean vehicle systems are not operating at their best.

NOTE: An estimation of installation time will be given before the software update starts. Installation can take several minutes. During installation individual functions and controls will not be available or only available to a limited degree.

4.07 Driver Display Overview: ICC5

4.07.01 General Description, ICC5 Display

The ICC5 driver display (or A-panel display) is used to communicate information about the current vehicles status and environmental information. The battery voltage, outside ambient air temperature, current time, and current compass direction are displayed across the top of the screen. Information such as fuel gauge, current speed, odometer reading, current gear, and primary and secondary air pressure gauges display on the bottom of the screen.

The driver display provides information in two different modes: a base screen layout (see Fig. 109, [Driver Display Base Screen - ICC5](#)) and a pilot screen layout (see Fig. 110, [Driver Display Pilot Screen - ICC5](#)). What screen displays depends on safety features installed and if the vehicle is in motion.

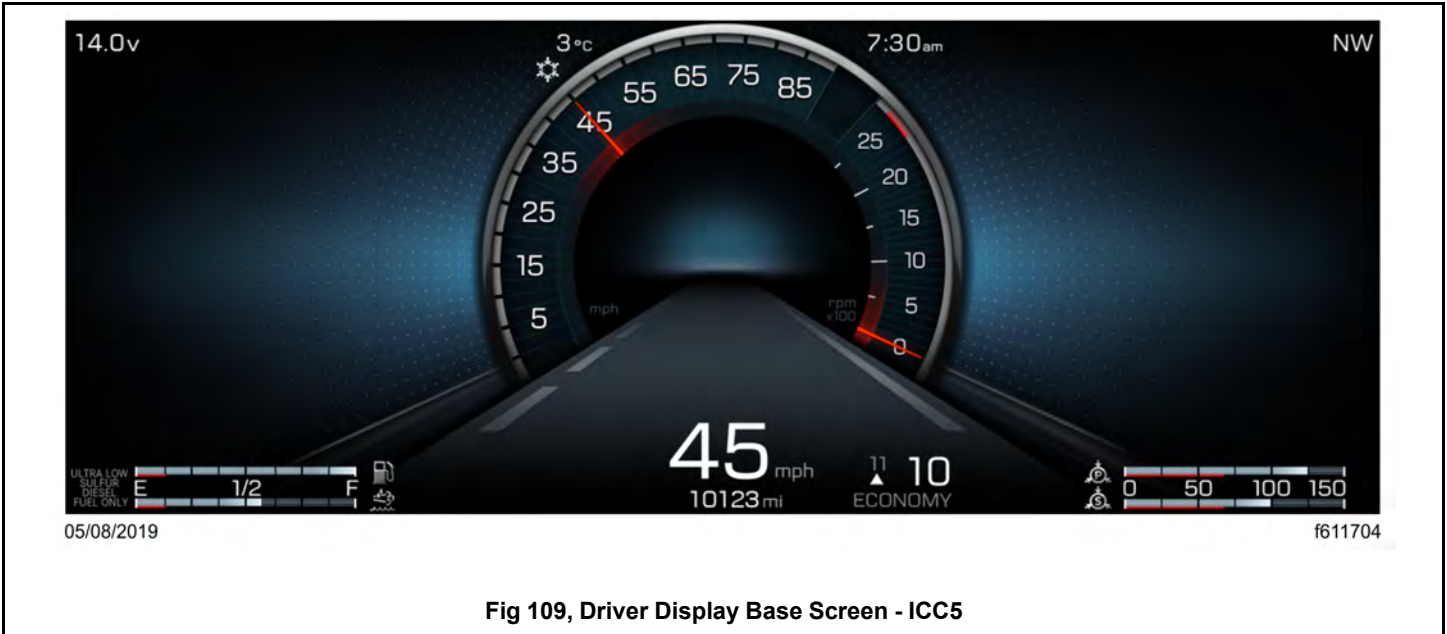
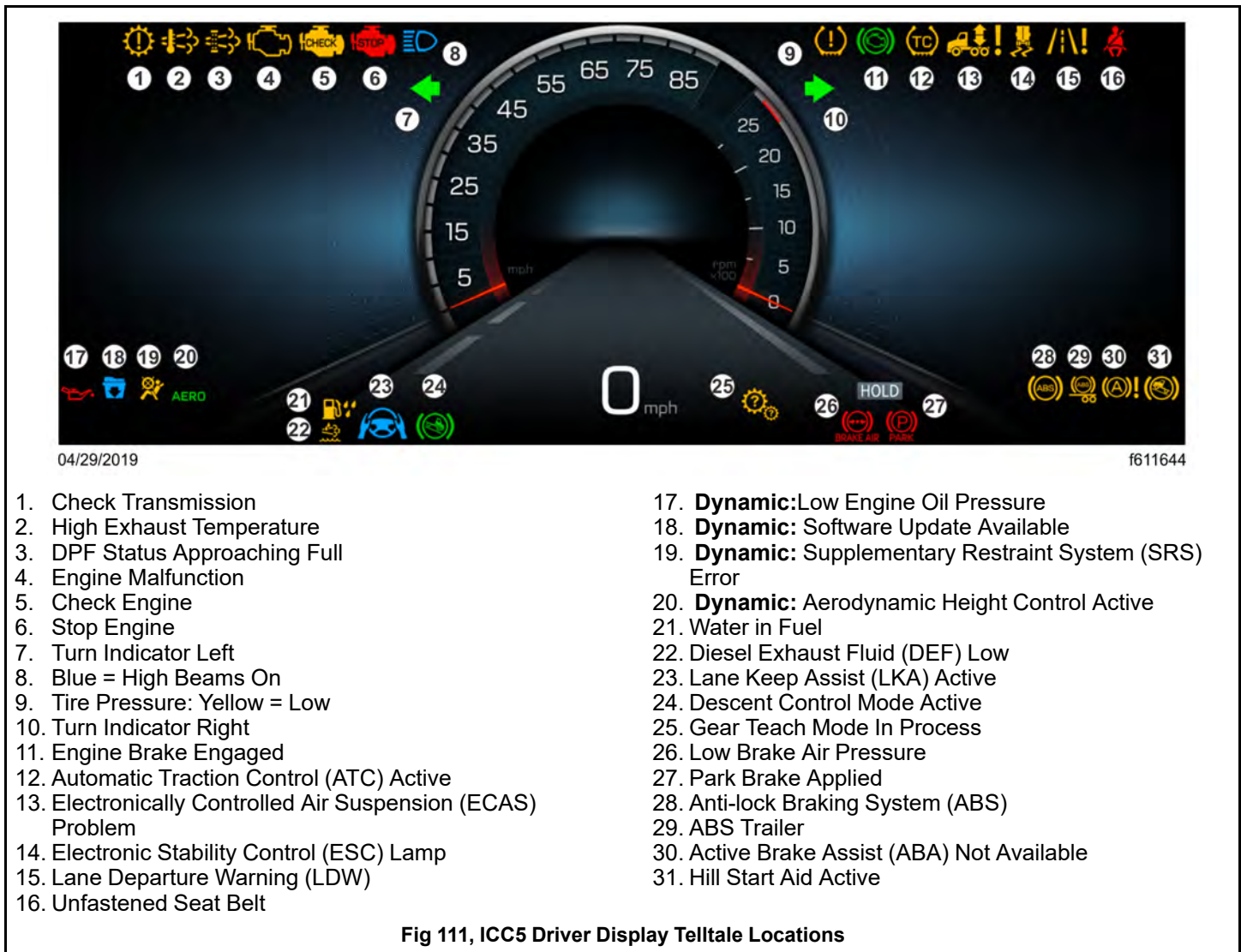

Fig 109, Driver Display Base Screen - ICC5



Fig 110, Driver Display Pilot Screen - ICC5

4.07.02 ICC5 Driver Display Screen



Each telltale has its screen location except for dynamic telltales which are displayed in positions 17-20 and sorted in priority order from right to left meaning position 20 has the highest priority. See Fig. 111, [ICC5 Driver Display Telltale Locations](#). If there are more than four dynamic telltales active, only the four highest priority ones are displayed.

NOTE: For a full list of telltales and their meanings, see **Warnings, Indicators, and Messages** in this chapter.

4.07.03 ICC5 Steering Wheel Buttons

To navigate features and screens, use the Optical Finger Navigation Control (OFN) buttons on the steering wheel.

The buttons in the left-hand pod control the driver display features. See Fig.

112, [Steering-Wheel-Mounted Left-Hand Switch Pod - ICC5](#). The buttons in the right-hand pod provide access to infotainment features and menus. See Fig. 113, [Steering-Wheel-Mounted Right-Hand Pod - ICC5](#).

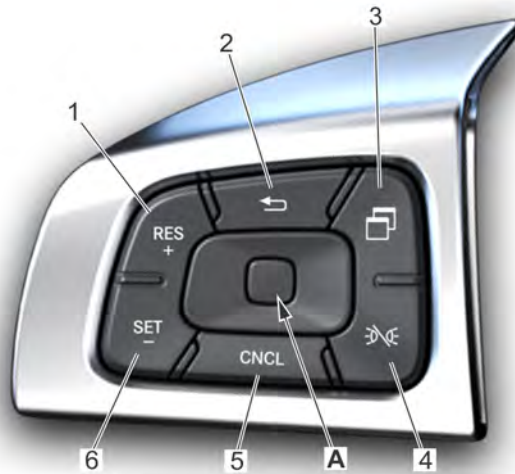

10/25/2018

f611531a

- | | |
|---|---|
| <p>A. Menu Button Press the button to access instrument panel menus. When the button is pressed, information appears on the driver display screen.</p> <p>1. Cruise Accelerate/Resume</p> <p>2. Back Button</p> | <p>3. Quick Access System Settings</p> <p>4. Marker Interrupt</p> <p>5. Cruise Cancel</p> <p>6. Cruise Decelerate/Set</p> |
|---|---|

Fig 112, Steering-Wheel-Mounted Left-Hand Switch Pod - ICC5

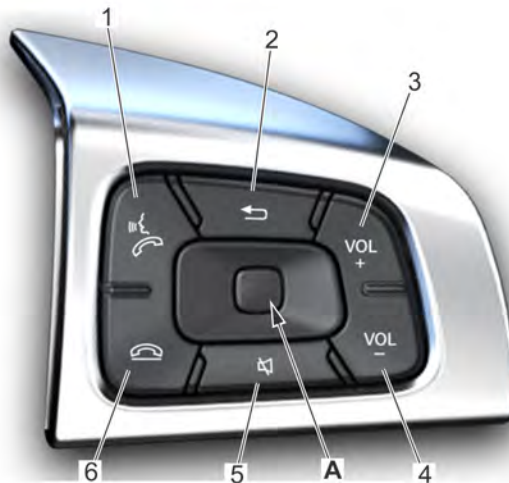

10/25/2018

f611531b

- | | |
|---|--|
| <p>A. Menu Button Press the button to access instrument panel menus. When the button is pressed, information appears on the 10-inch head unit screen.</p> <p>1. Phone Pick-Up</p> <p>2. Back Button</p> | <p>3. Volume Increment Up</p> <p>4. Volume Increment Down</p> <p>5. Mute Button</p> <p>6. Phone Hang-Up/Reject</p> |
|---|--|

Fig 113, Steering-Wheel-Mounted Right-Hand Pod - ICC5

4.07.04 Basic ICC5 Functions

ICC5 Alert Messages

Alert messages appear on the driver display when certain conditions occur. They include warnings, cautions, and notices that require the driver's attention. Not all alert messages are critical to the operation of the vehicle. More important messages take priority over less important messages. The header text and color indicates the priority of the on-screen message, listed from the highest to the lowest:

- Warning (red)
- Caution (amber)
- Status/Informational (blue, green, white, and grey)

Warnings alert the driver to situations or conditions that may pose a threat to control of the vehicle. Follow all instructions given in the message.

Cautions alert the driver to situations or conditions that may result in damage to vehicle components, or derating of engine power.

Status notices alert the driver to situations or conditions that may improve fuel efficiency or vehicle handling.

ICC5 Time and Date Settings

The following settings can be controlled under Time and Date: selecting a time zone, turning Automatic Summer Time on or off, turning Summer Time on or off, and setting the date and time format.

Automatic Summer Time is another name for automatic daylight saving time. If this is set to on then the controls for Summer Time are unavailable.

Dates can be displayed as: DD.MM.YYYY, MM/DD/YYYY, or YYYY/MM/DD. Selection is made using either/or radio buttons.

Time can be displayed in 12 AM/PM or 24 hour format.

ICC5 Alarm Settings

NOTE: The ability to set the alarm clock and timers is only available when the parking brake is engaged.

Alarm Clock Controls and Features:

- Time of Day
- Repeat
- Audio Source
- Light Alarm

Tapping on a bar at the bottom of the screen in the alarm clock menu switches between alarm clocks and the sleep timers. If alarms have been set, the corresponding icon in the bar indicates this with the number of active alarms shown inside a circle.

Up to fifteen alarms can be shown in a carousel view on the screen. They are sorted from the beginning of the day on the left and the end of the day on the right. If less than fifteen alarms have been set, a Add Alarm icon will be available in carousel display at the far right. If fifteen alarms have been created, the Add Alarm icon is not available.

New alarms are set to be On when created. Alarms can be toggled off and on by pressing on an alarm tile. An active alarm has a red line at the top of the alarm tile.

If an alarm has been set to repeat, the selected days of the week will be listed below the time.

The audio of an alarm can be set under Audio Source. Options include up to 15 preset alarm sounds and any available radio station.

If an alarm includes turning on lights, a light icon is shown on the alarm tile at the bottom right. Wake up lighting can be set to be turned on at 10% to 100% brightness.

Alarms can be edited by pressing on the pencil icon below the alarm tile. To delete an alarm, press on the edit pencil icon and choose Delete.

ICC5 Sleep Timer Settings

The sleep timer's function is to turn off the light(s) and/or music after a certain period of time. The default value is 30 minutes but the sleep timer can be set anywhere from 1 minute to 3 hours and 59 minutes.

ICCC5 Temperature

NOTE: Pay attention to road conditions when air temperatures are near freezing.

In the ICC5 the ambient air temperature displays at the top and slightly to the right on the driver display screen. See Fig. 114, [Driver Display Base Screen - ICC5](#). The temperature can be set to display in °F or °C in Settings.

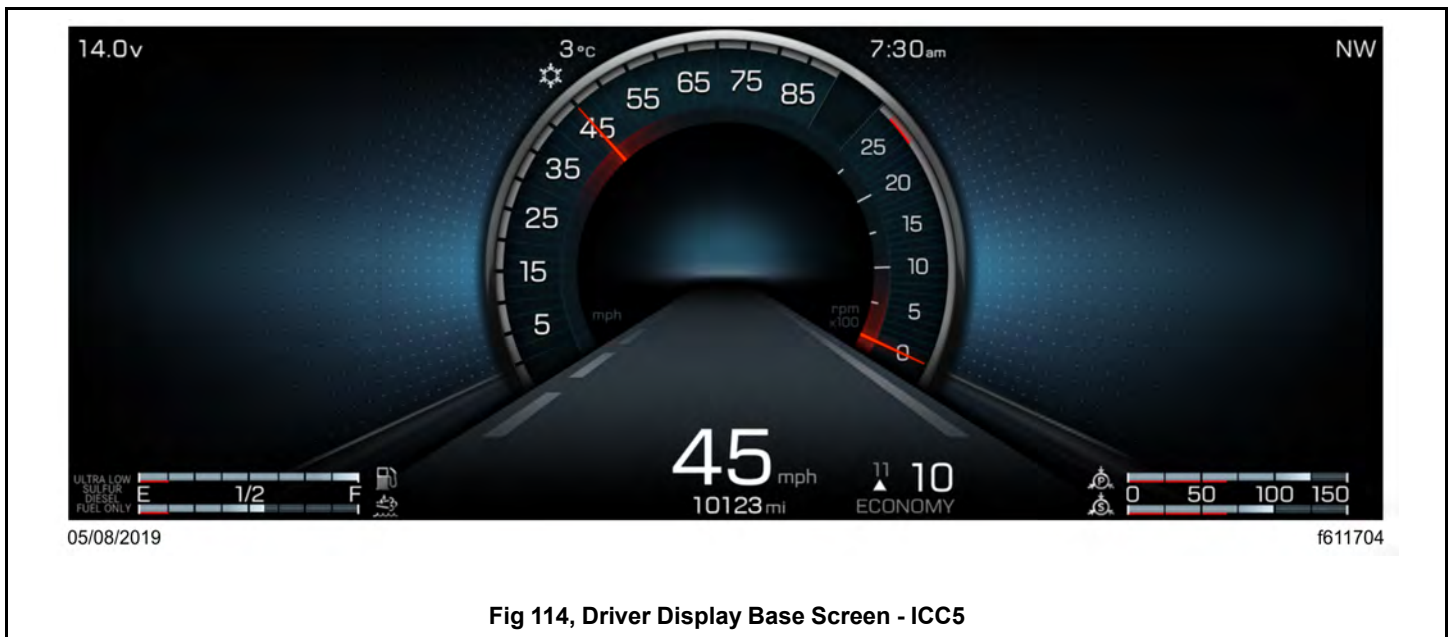

Fig 114, Driver Display Base Screen - ICC5

When ambient air temperature drops below 34°F (1°C), a snowflake icon will appear below the display temperature. The snowflake icon will display until the ambient air temperature rises to 37°F (3°C).

If the temperature drops below 34°F (1°C) after rising above 37°F (3°C), the snowflake will reappear.

4.08 Digital Gauges and System Monitors: ICC5

4.08.01 ICC5 Gauges

There are thirteen digital gauges under the Gauges menu on the B-panel or infotainment display. See Fig. 115, [Example Gauge Screen - ICC5](#) for an example screen overview. Twelve are informational only; if active, Soot Level includes a button to start a regeneration.

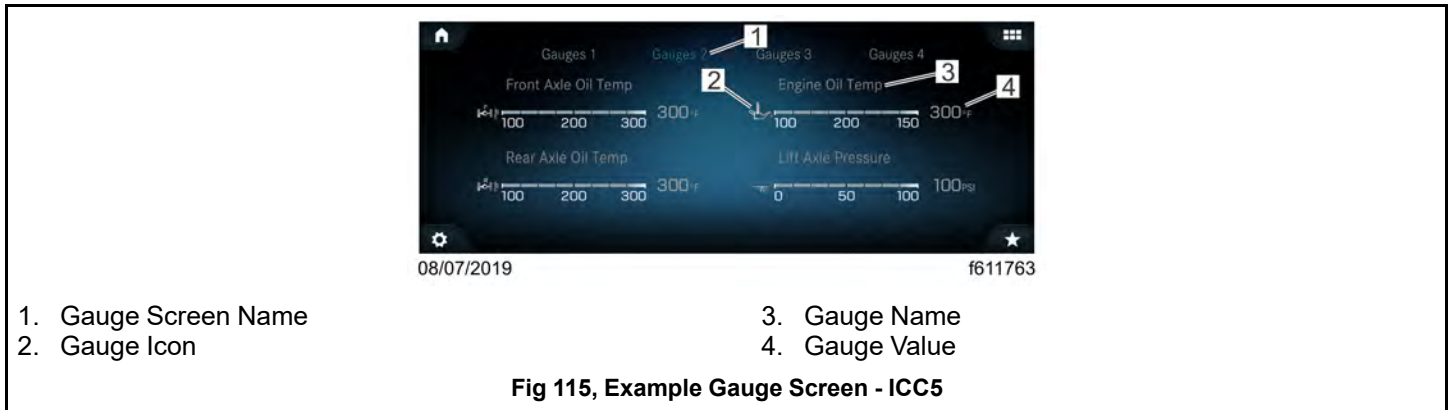

The default display order of gauges is as follows:

- Coolant Temperature
- Engine Oil Pressure
- Engine Oil Temperature
- Transmission Oil Temperature
- Front Axle Oil Temperature
- Rear Axle Oil Temperature
- Lift Axle Pressure
- Soot Level
- Application Air Pressure
- Suspension Air Pressure
- Trailer Application Air Pressure
- Trailer Suspension Air Pressure
- Turbo Boost Pressure

The default can be changed. Pressing on an existing gauge will cause a popup window to appear with the option to either Remove or Replace the gauge. Choosing Replace will bring up a radio button list of all available gauges from which to choose; replacing a gauge will move the first gauge into a different screen placement. Removing a gauge removes the gauge from the gauge screens. A removed gauge can be added back by pressing the Add or plus sign button. Doing so will cause a radio button list to appear listing the gauges available to be added.

Gauge units of measurements are controlled under Settings which can be accessed under the Cab menu or by pressing the star menu icon in the lower left corner.

Moving between gauge screens can be accomplished by pressing the gauge screen name at the top of the screen.

In the ICC5, if a value measured by a digital gauge exceeds the normal range, the gauge icon, display bar graph color, and gauge value will change color to amber to indicate caution or red to indicate danger. See Fig. 116, [Gauge Caution & Warning Indicator Display - ICC5](#).

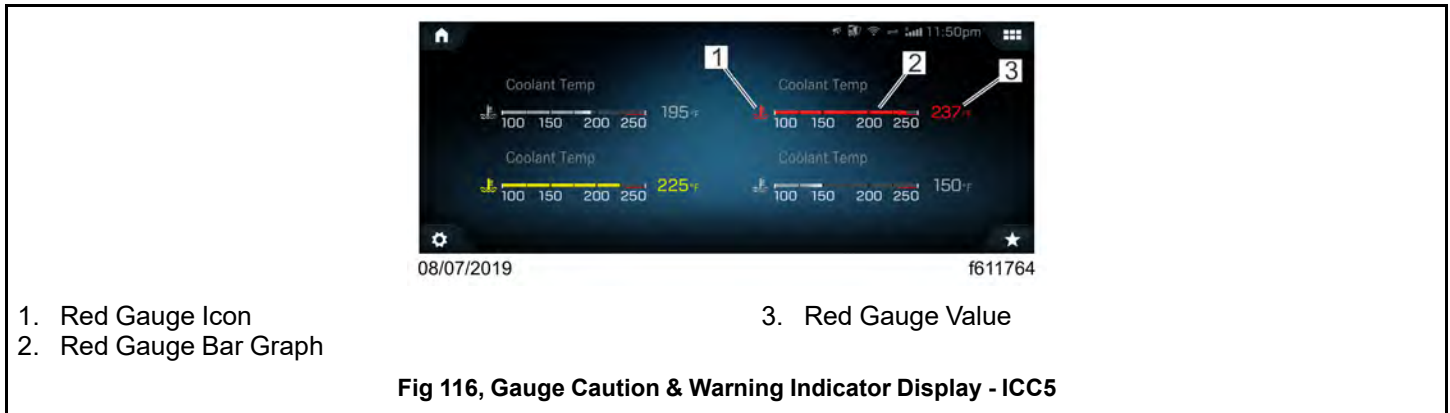

Fig 116, Gauge Caution & Warning Indicator Display - ICC5

Gauge information can also be viewed on the driver display. See Fig. 117, [Coolant Temperature & Engine Oil Pressure on Driver Display - ICC5](#).

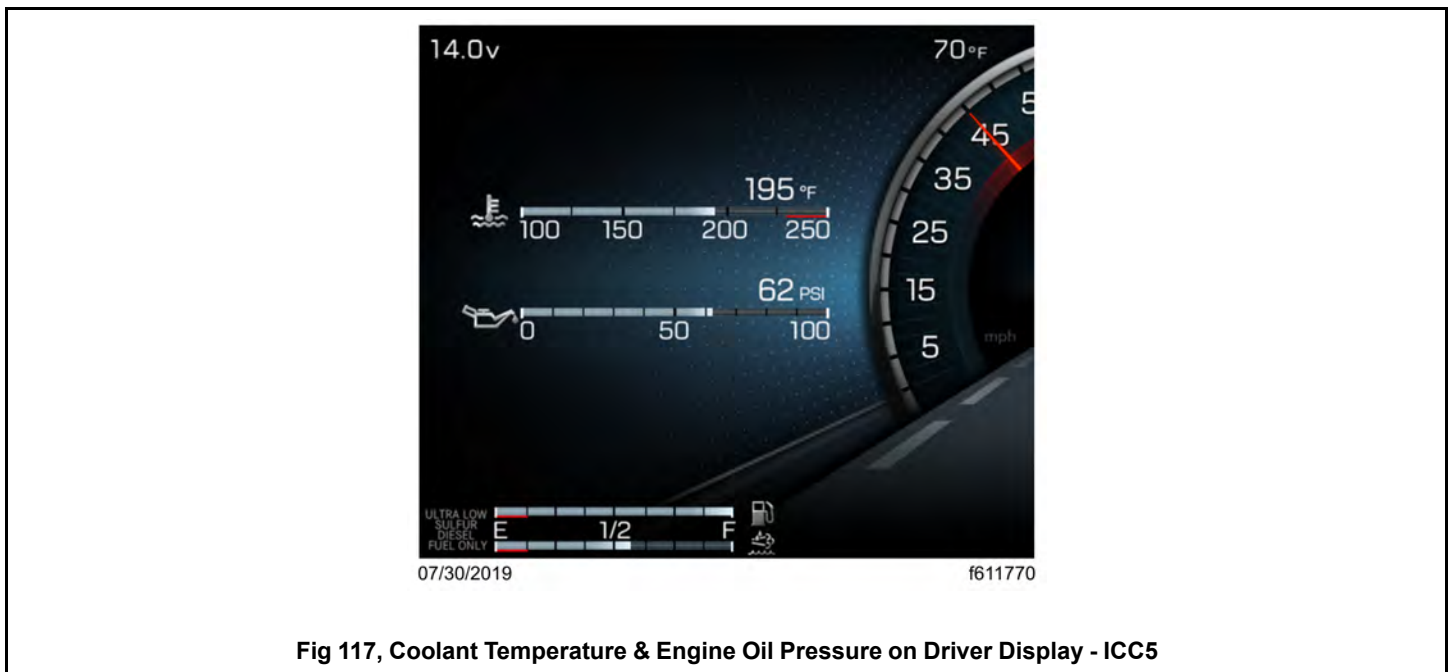

Fig 117, Coolant Temperature & Engine Oil Pressure on Driver Display - ICC5

4.08.02 Coolant Temperature Gauge



NOTICE:

A sudden increase in coolant temperature may indicate engine or cooling system failure. Bring the vehicle to a safe stop and investigate the cause to prevent further damage. Do not operate the engine until the cause has been determined and corrected.

During normal engine operation, the coolant temperature gauge should read 175 to 195°F (79 to 91°C). If the temperature remains below 160°F (71°C), inspect the cooling system to determine the cause.

For Detroit engines, if coolant temperature rises above the maximum temperature listed in Table.6, [Maximum Coolant Temperature](#), the CHECK engine lamp will illuminate. If the condition does not improve, the STOP engine lamp will also

illuminate and an audible warning will sound. The engine will then derate or shut down, depending on the type of engine protection system installed.

For Cummins engines, the fan will come on when coolant the temperature reaches 215°F (101°C) and the check engine light will illuminate when coolant temperature rises above the maximum temperature listed in Table 6, [Maximum Coolant Temperature](#).

| Engine Make | Temperature: °F (°C) |
|------------------------|----------------------|
| Cummins | 221 (105) |
| Detroit DD13/DD15/DD16 | 234 (112) |

Table 6, Maximum Coolant Temperature

4.08.03 Engine Oil Pressure Gauge



NOTICE:

A sudden decrease or absence of oil pressure may indicate mechanical failure. Bring the vehicle to a safe stop and investigate the cause to prevent further damage. Do not operate the engine until the cause has been determined and corrected.

Except for Detroit Gen 5 DD13 and DD15 engines, the engine oil pressure gauge displays the current engine oil pressure. If engine oil pressure falls below the minimum levels shown in Table 7, [Minimum Engine Oil Pressure](#), the CHECK engine lamp on the driver display will illuminate. If the condition does not improve, the STOP engine lamp will also illuminate and an audible warning will sound. The engine will then derate or shut down, depending on the type of engine protection system installed.

NOTE: Oil pressures are given with the engine at operating temperature. With the engine cold, oil pressure may be higher. Individual engines may vary from the listed pressures; observe and record pressures when the engine is new to create a guide for checking engine condition.

| Engine Model | At Idle Speed: ¹ psi (kPa) | At Rated RPM: ² psi (kPa) |
|---------------------------|--|---|
| Cummins | 15 (103) | 35 (241) |
| Detroit Gen 5 DD13/DD15 | 50 (344) | 50 (344) |
| All Other Detroit Engines | 14 (97) | 55 (350) |

1. Standard idle speed is 600 RPM. Actual engine idle speed can vary ± 100 RPM depending on transmission type.

2. All Detroit heavy-duty engines are rated at 1800 RPM.

Table 7, Minimum Engine Oil Pressure

For Detroit Gen 5 DD13 and DD15 engines, the gauge will read a steady 50 psi (344 kPa) with normal engine oil pressure. If the engine oil pressure is low, the CHECK lamp will illuminate and the oil pressure gauge will read 25 psi (172 kPa). If the condition does not improve, the STOP lamp will illuminate, an audible warning will sound, and the gauge will read 0 psi. The engine will then derate or shut down, depending on the type of engine protection system installed.

4.08.04 Engine Oil Temperature Gauge

**NOTICE:**

A sudden increase in oil temperature that is not caused by a load increase may indicate mechanical failure. Bring the vehicle to a safe stop and investigate the cause to prevent further damage. Do not operate the engine until the cause has been determined and corrected.

During normal operation, the optional engine oil temperature gauge should read in the following temperature range:

- 200 to 260°F (93 to 126°C) for Detroit and Cummins engines

Under heavy loads, such as when climbing steep grades, temperatures that exceed the normal oil temperature range for a short period are not unusual. If the temperature returns to normal when the load decreases, there is no problem.

4.08.05 Transmission Oil Temperature Gauge

The transmission fluid temperature gauge measures the transmission lubricant operating temperature. Temperatures vary by application, but the transmission fluid temperature gauge reading should not exceed 250°F (121°C).

**NOTICE:**

A sudden increase in transmission fluid temperature that is not caused by a load increase may indicate mechanical failure. Bring the vehicle to a safe stop and investigate the cause to prevent further damage. Do not operate the vehicle until the cause has been determined and corrected.

Under heavy loads, such as when climbing steep grades, temperatures that exceed the normal oil temperature range for a short period are not unusual. If the temperature returns to normal when the load decreases, there is no problem.

4.08.06 Drive Axle Oil Temperature Gauges

**NOTICE:**

A sudden increase in oil temperature that is not caused by a load increase may indicate mechanical failure. Bring the vehicle to a safe stop and investigate the cause to prevent further damage. Do not operate the vehicle until the cause has been determined and corrected.

During normal operation, drive axle oil temperature gauges should read as follows:

- 160 to 220°F (71 to 104°C) for Detroit® Classic Model 2, 4, and 6 axles.
- 160 to 329°F (71 to 165°C) for Detroit® New Final Drive (NFD) axles.
- 160 to 329°F (71 to 165°C) for Detroit® Adaptive Tandem 6 X 4 axles.
- 160 to 275°F (71 to 135°C) for Meritor drive axles.
- 180 to 200°F (82 to 93°C) for Dana Spicer® drive axles.

Under heavy loads, such as when climbing steep grades, temperatures that exceed the normal oil temperature range for a short period are not unusual. If the temperature returns to normal when the load decreases, there is no problem.

4.08.07 Lift Axle Pressure Gauge

The lift axle pressure gauge registers the air pressure applied to the lift axles.

4.08.08 DPF Soot Level Gauge

See the chapter on **Emissions and Fuel Efficiency** for details of Diesel Particulate Filter and DEF level monitoring.

4.08.09 Application Air Pressure Gauge

An application air pressure gauge registers the air pressure being used to apply the brakes. The gauge will not register air pressure until the foot brake pedal is depressed or the trailer hand brake is applied.

4.08.10 Suspension Air Pressure Gauge

The suspension air pressure gauge registers the air pressure applied to the vehicle air suspension.

4.08.11 Trailer Application Air Pressure Gauge

The trailer application air pressure registers the applied air pressure in the brake circuit.

4.08.12 Turbo Boost Pressure Gauge

The turbo boost pressure gauge registers the pressure in the intake manifold, in excess of atmospheric pressure, being created by the turbocharger.

4.08.13 Base ICC5 A-Panel Gauges

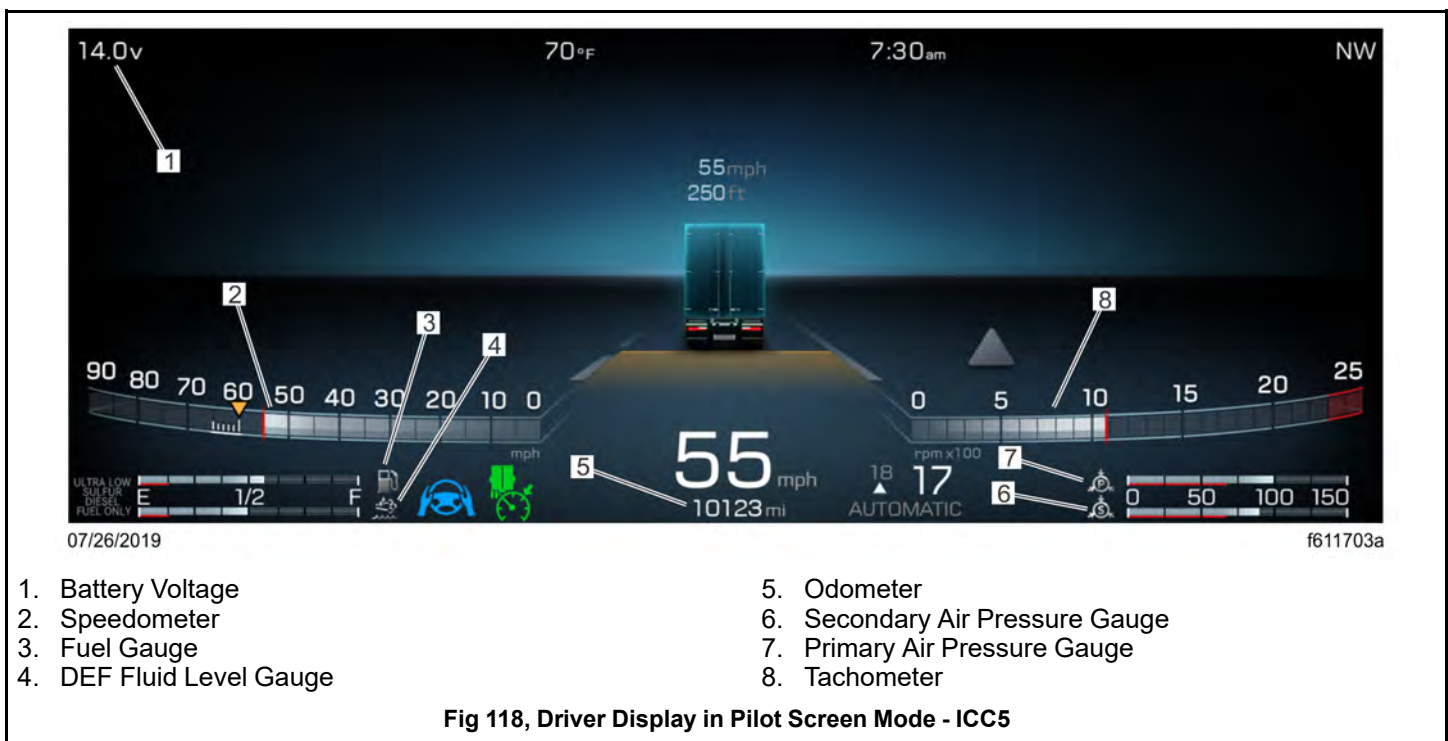

Outside of the gauges screen, the ICC5 offers a number of other digital gauges and instruments.

4.08.14 Battery Voltage

The ICC5 A-panel displays the vehicle charging system voltage in the upper left corner. By monitoring this number, the driver can stay aware of potential battery charging problems and have them fixed before the batteries discharge enough to create starting difficulties.

The driver display will normally show approximately 13.7 to 14.1 volts when the engine is running. The voltage of a fully charged battery is 12.7 to 12.8 volts when the engine is off. Battery voltage under 12.0 volts is considered a low battery, and a completely discharged battery will produce only about 11.0 volts.

If the driver display screen shows an undercharged or overcharged condition for an extended period, have the charging system and batteries checked at an authorized Freightliner service facility.

4.08.15 Speedometer and Tachometer

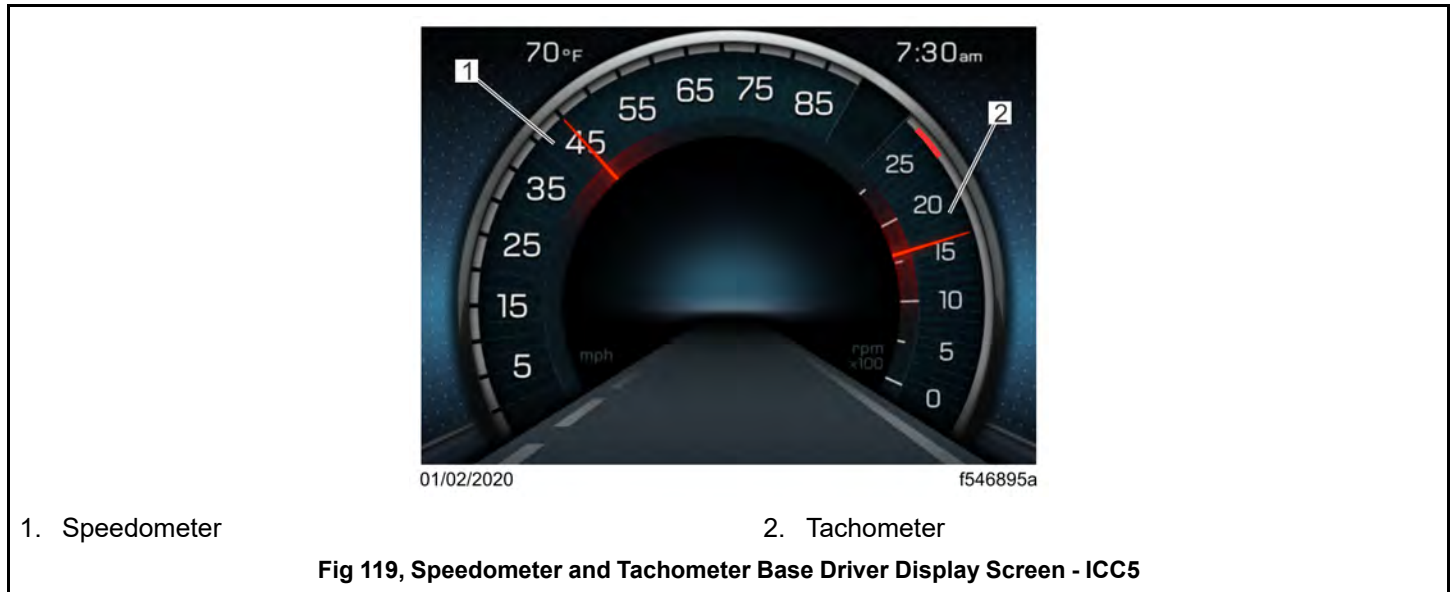

In the ICC5 the speedometer and tachometer are combined. On the driver display base screen the information is presented as a centered arch (see Fig.119,[Speedometer and Tachometer Base Driver Display Screen - ICC5](#)). On the driver display pilot screen, it becomes a split band near the bottom of the screen (see Fig. 120,[Driver Display in Pilot Screen Mode - ICC5](#)).

The speedometer registers the speed of the vehicle.



The tachometer indicates engine speed in revolutions per minute (rpm) and serves as a guide for shifting the transmission and keeping the engine in the appropriate rpm range. The tachometer has an overspeed zone, marked in red, from 2300 to 2500 rpms.

The speedometer and tachometer and measure miles per hour (mph) or kilometers per hour (km/h), depending on the option selected in the system settings.

4.08.16 Fuel Level Gauge

Fuel levels are indicated on a gauge in the lower left corner of the driver display screen above the DEF level gauge. The fuel pump icon to the right of the gauge will illuminate amber when the diesel fuel level registers 1/8th of capacity and stay amber until the fuel tank is refilled.

4.08.17 Diesel Exhaust Fluid (DEF) Level Gauge

The driver display screen shows a DEF level gauge in the lower left hand corner below the fuel gauge. When the DEF level reaches 1/8th of capacity, the low DEF icon and the remaining measurement bar illuminate amber. The bar will continue to remain amber as it decreases until the DEF tank is empty, at which point only the low DEF icon will remain lit. See the chapter on **Emissions and Fuel Efficiency** for more details on the DEF level gauge.

4.08.18 Odometer

The odometer is located below the speed indicator at the bottom center of the screen. See Fig. 121, [Driver Display in Pilot Screen Mode - ICC5](#). Depending on what values are chosen in the Settings menu, the odometer will display engine miles driven in mph or km. The display units can be changed at any time.



4.08.19 Primary and Secondary Air Gauges

Primary and secondary air gauges are stacked in the lower right corner of the A-panel display. See Fig. 122, [Driver Display in Pilot Screen Mode - ICC5](#). When the air pressure drops too low, both the air pressure measurement and the air pressure icon will change color. A complete lack of air pressure will result in only the icon being either amber (caution) or red (danger).

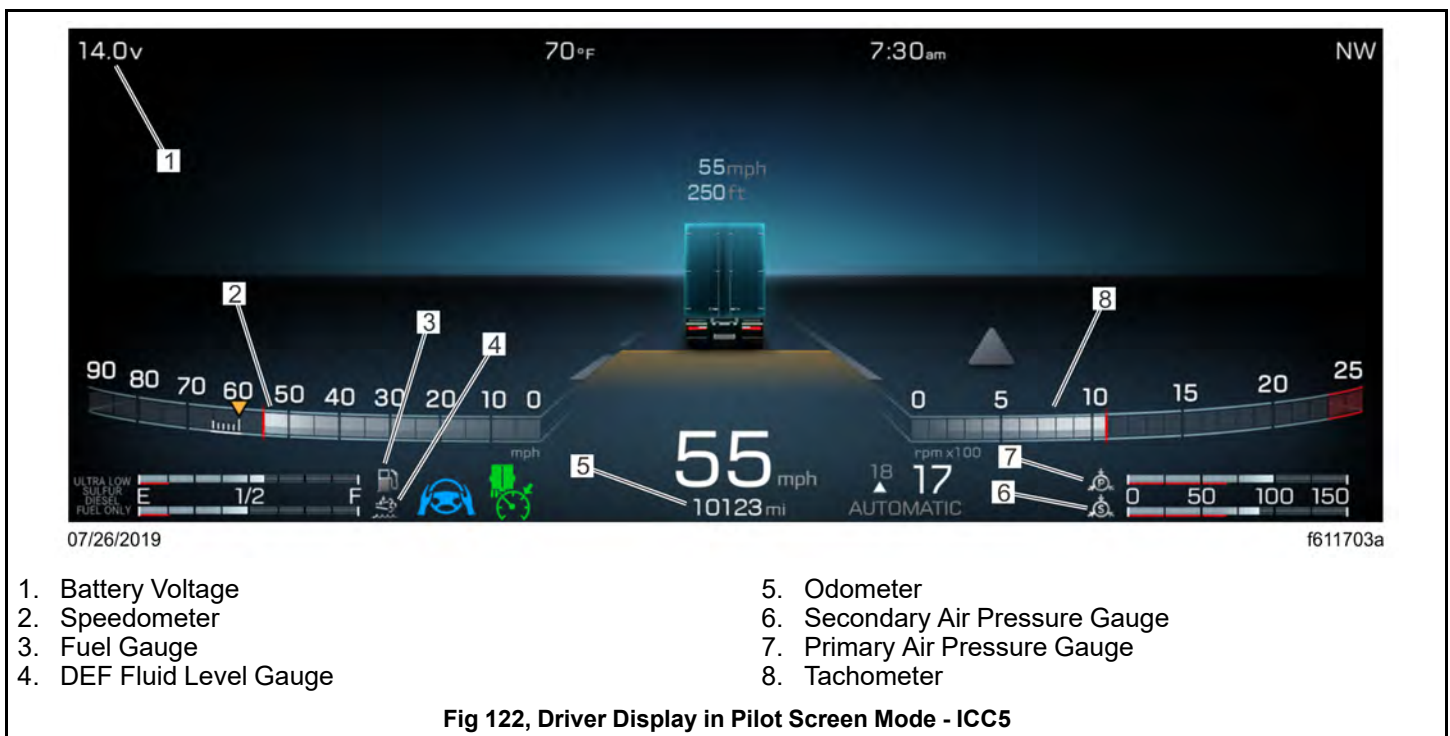

4.08.20 Floating ICC5 A-Panel Gauges

Vehicle information can also be accessed on the driver display or A-panel screen by moving through versions of the base layout.

The gauge information available on the infotainment or B-panel screen shows up on the left side of the speedometer/tachometer. See Fig.123,[Coolant Temperature & Engine Oil Pressure on Driver Display - ICC5](#)..

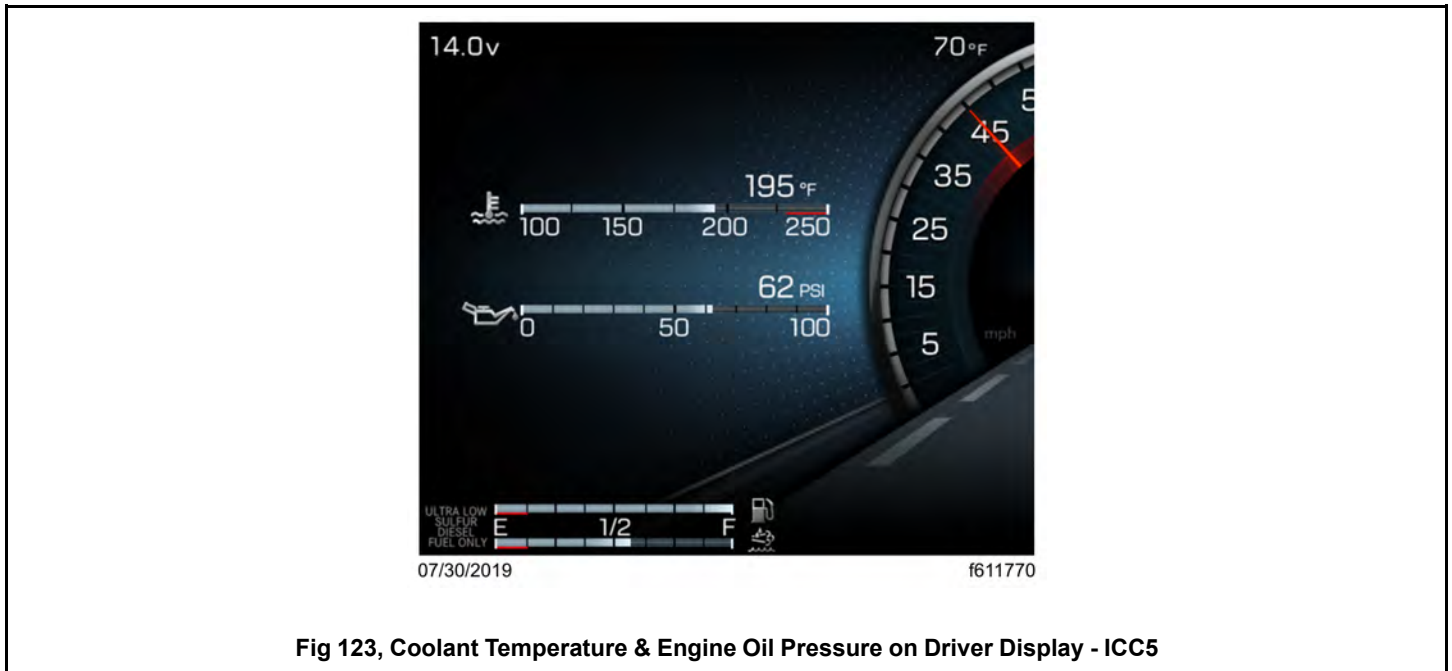

Safety feature graphics and pop-up screens appear in the center and feature related icons appear at bottom center of the screen.

Data such as trip information, fuel consumption, and eco driver feedback appear to the right of the speedometer/tachometer. See Fig.124,[Eco Driver Feedback on the Driver Display - ICC5](#).

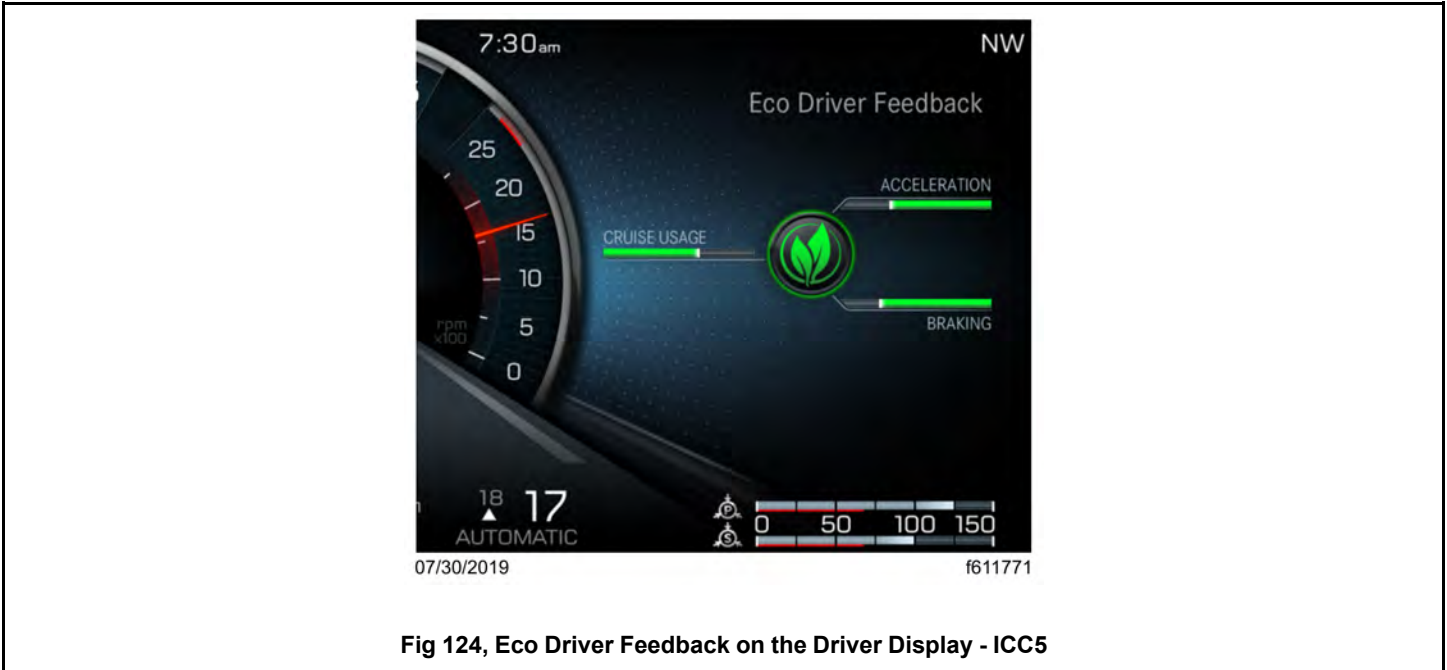

Fig 124, Eco Driver Feedback on the Driver Display - ICC5

4.08.21 Eco Driver Feedback

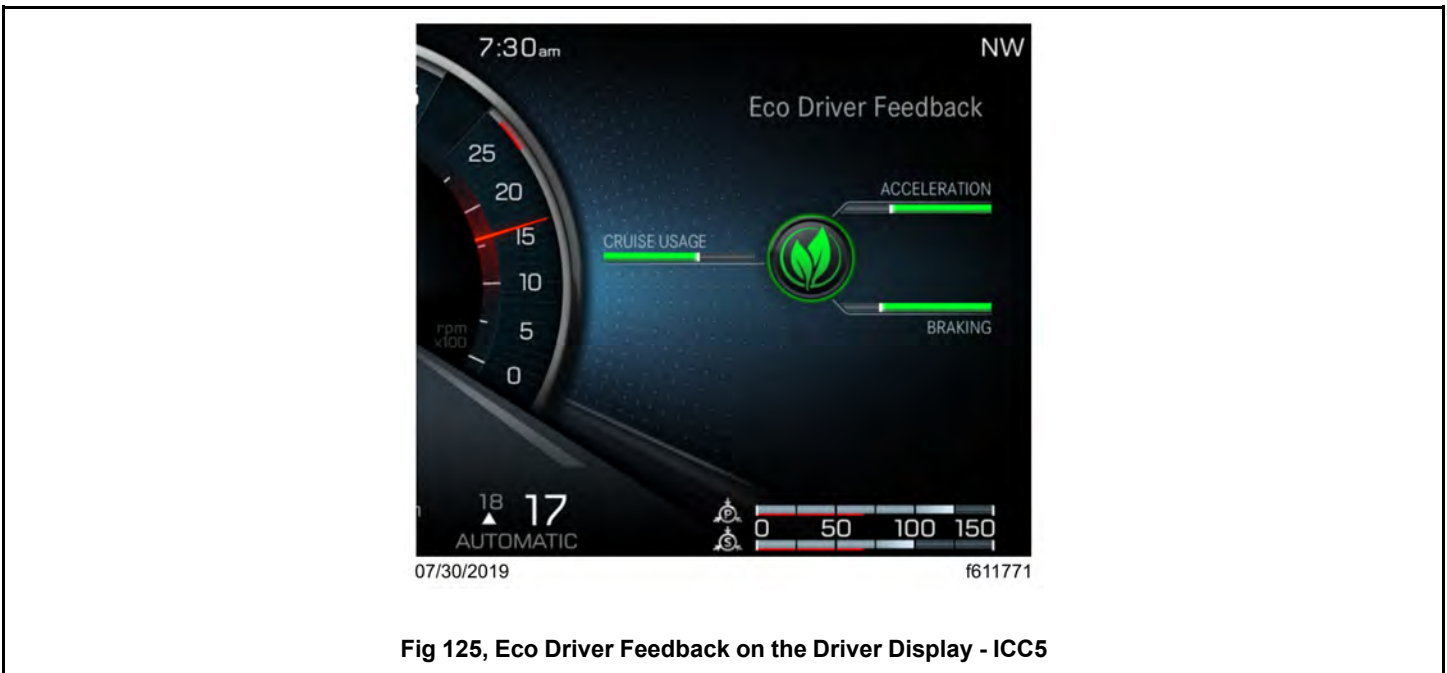

Fig 125, Eco Driver Feedback on the Driver Display - ICC5

NOTE: The Eco Driver feature was discontinued in January 2020.

Eco Driver Feedback encourages a driver to make economical driving a habit with the goal of saving fuel and reducing wear. See Fig.125, [Eco Driver Feedback on the Driver Display - ICC5](#).

Eco Driver Feedback gauges, displayed on the right-hand side of the driver display, show a driver's performance in three categories: gentle braking, smooth acceleration, and cruise control usage. Performance is newly calculated with each vehicle start.

Examples of driving behavior that increases or decreases the amount of green in each column are as follows:

- Time in cruise control increases the Cruise Control Usage value.
- Failure to engage cruise control after the Use Cruise Control popup appears decreases the Cruise Control Usage value
- Pumping the accelerator pedal decreases the Smooth Acceleration value.
- Keeping the speed steady with cruise control off increases the Smooth Acceleration value.
- Sudden braking outside of an urban environment decreases the Gentle Braking value.
- No incidences of sudden breaking over time increases the Gentle Braking value.

4.08.22 ICC5 B-Panel Chassis Status Information

In addition to controls and gauges, the ICC5 B-panel provides access to chassis status information:

- Tire Pressure Monitoring System
- Axles
- Maintenance System
- Diagnostics
- Active Driver Alerts

4.08.23 Tire Pressure Monitoring System (TPMS)

The tire pressure monitoring system displays tire pressure, temperature, and sensor status. Maintaining correct tire pressure increases fuel economy. Sustained high tire temperature can cause a tire to deteriorate, leading to tread separation and blowouts.

Tire Pressure has three submenu options: tire pressure, tire temperature, and sensor status. Selecting the tire icon image will display a vehicle image on the screen showing the tire pressure for each tire. Tire pressure can be displayed in psi or bar units. The unit of measure is displayed behind the rear left tire on the vehicle image. See Fig. 126, [TPMS: Tire Pressure - ICC5](#). Units of measure are set under Settings.

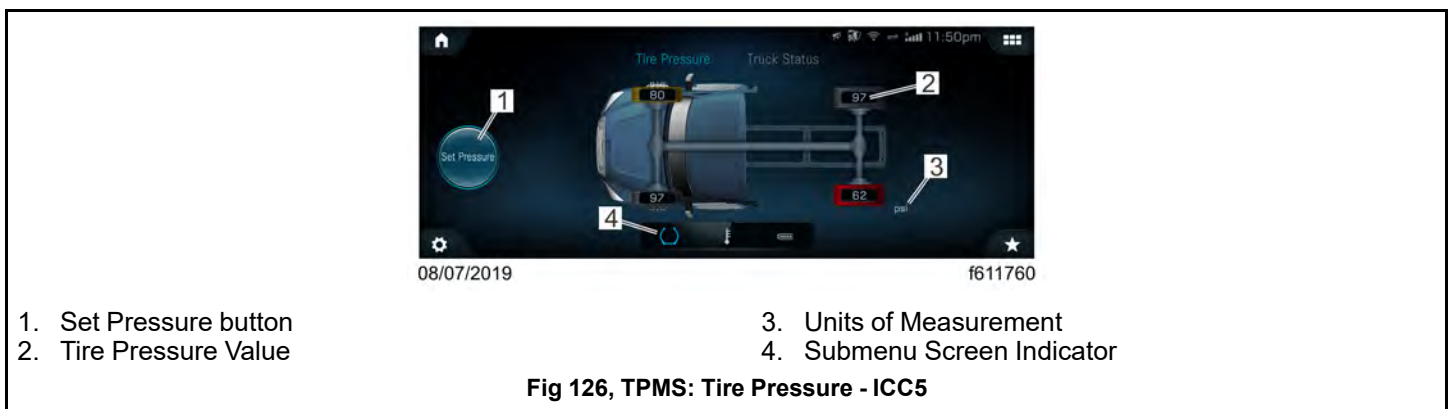

Tires on the truck image will change color if tire pressure is too high or too low based on factory settings. Red indicates a condition that may pose a threat to the control of the vehicle. Amber indicates a condition that may result in damage. See Fig.127, [TPMS: Tire Temperature- ICC5](#),

The option to Set Pressure is available on the tire pressure screen. Selecting this option allows you to change default settings.

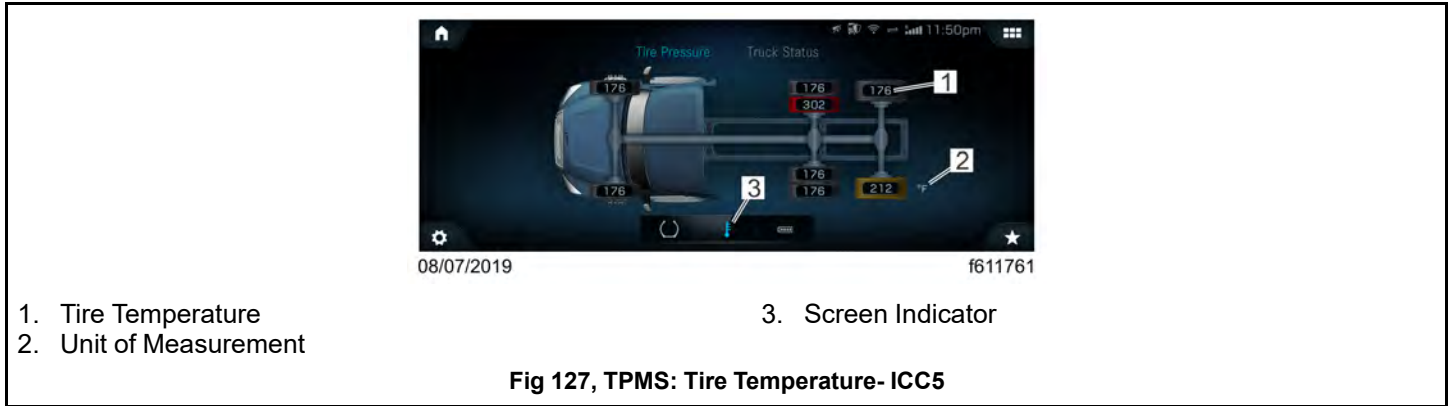

Selecting the temperature icon will show an image of the vehicle on the screen showing the temperature of each tire. Tire temperature can be displayed in Fahrenheit or Celsius. The unit of measure is displayed behind the rear left tire on the vehicle image. Units of measure are set under Settings.

Tires on the truck image will change color if tire temperature is too high. Red indicates a condition that may pose a threat to the vehicle. Amber indicates a condition that may result in damage.

Selecting the battery icon will show the battery strength of each tire sensor.

If a sensor's battery life is low, both the tire and the sensor icon on the truck image will change color to amber. If sensor battery status is critically low they will become red. See Fig.128, [TPMS: Sensor Status - ICC5](#).

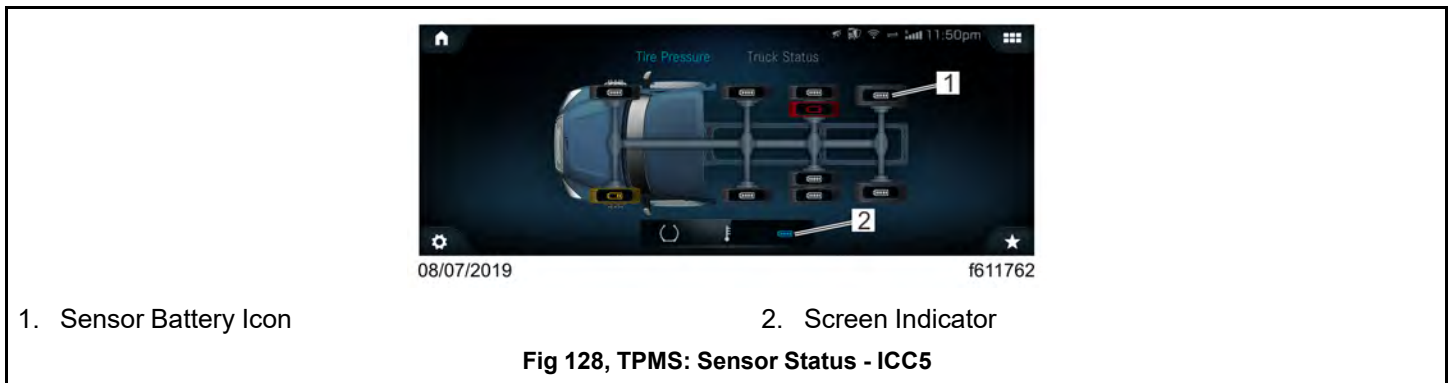

4.08.24 Axles

This menu provides access to the axle locks status screen showing engaged locks.

For more information see the chapter on **Drive Axles**.

4.08.25 Maintenance System

NOTE: the wrench icon indicates a need for maintenance, not something broken that needs to be fixed.

Standard messaging is based on the number of miles (km) driven or time passed since the last service.

Predictive maintenance information is calculated based on these factors as well as engine and transmission load and oil temperature.

Currently, predictive maintenance information is given for engine oil, transmission oil, and axle oil changes. By taking driving conditions into account, predictive maintenance provides more accurate intervals for fluid changes.

Just before the service interval ends, a message that maintenance is due will appear. See Fig. 129, [Example ICC5 Maintenance Screen - ICC5](#).

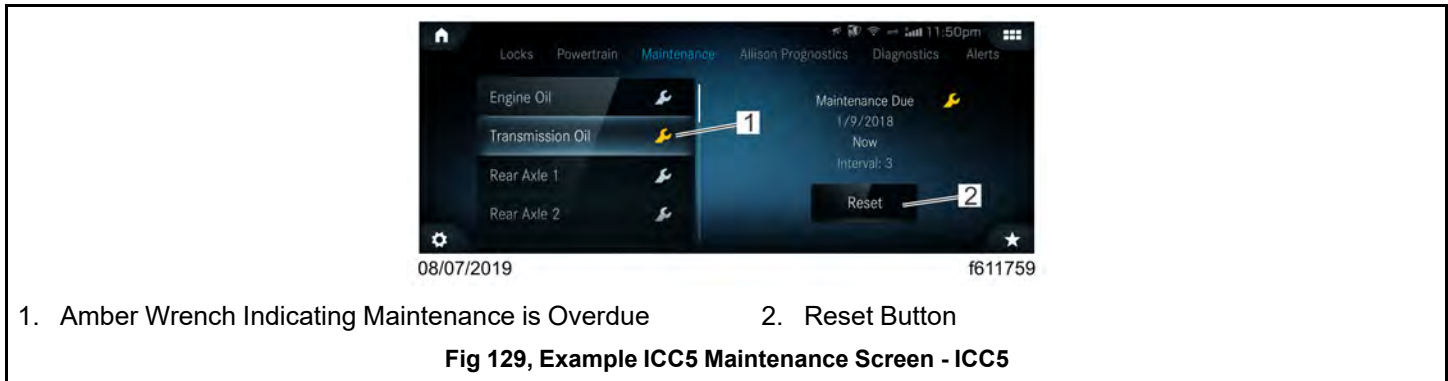

When the service interval is reached, a pop-up notice that maintenance is due will appear with every key cycle.

When the service interval is overdue, the color of the wrench icon on the maintenance screen will change from white to amber and the message will change to Maintenance Overdue. This cautionary pop-up will continue to appear with every key cycle.

The color of the wrench icon on the maintenance screen will change from white to amber when a maintenance service is overdue.

A service interval countdown can be reset by pressing the reset button which will cause a confirmation pop-up message to appear. If the required maintenance has been carried out, click Yes. Resetting the maintenance system when service is performed creates accurate future service intervals.

The reset button for maintenance system screens will not appear until the vehicle has been driven 6.2 miles and the engine has run for fifteen minutes.

Maintenance system information and service recommendations can also be viewed in the Detroit Connect portal. Information on the portal is updated every seven days.

4.08.26 Diagnostics

The Diagnostics screen communicates fault codes and other diagnostic information about the vehicle.

Fault codes are color-coded to indicate the severity of the fault. Red indicates a condition that may pose a threat to control of the vehicle. Amber indicates a condition that may result in damage to vehicle components or derating of engine power. Grey indicates a condition that may affect fuel efficiency or vehicle handling.

4.08.27 Active Driver Alerts

The Active Driver Alerts screen stores the current active alerts.

Alerts are color-coded to indicate severity. Red indicates a condition that may pose a threat to control of the vehicle. Amber indicates a condition that may result in damage to vehicle components or derating of engine power. Grey is used for notices.

4.08.28 ICC5 B-Panel Controls

In addition to the features described above, the ICC5 B-panel provides a number of digital controls and environmental information. Under the Cab menu this includes:

- Digital Switches
- Optimized Idle
- Settings

4.08.29 Digital Switches









| | | | | |
|---|---|---|---|---|
|  |  |  |  |  |
| Lane Departure Warning | Inhibit Regeneration | Active Traction Control | Power Takeoff 1 | Air Suspension Level Up |
|  |  | |  |  |
| Lane Keep Assist Active | Regeneration Activation | | Power Takeoff 2 | Air Suspension Level Down |

Table 8, Example of Digital Switch Icons and Layout

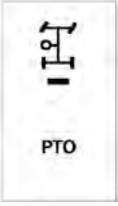
Digital switches can be used to turn different vehicle functions on or off. An indicator at the top of the digital button shows the status of the switch with a red line indicating On.

the arrangement of the switches depends on the features of the vehicle. In general switches are grouped into pairs stacked on top of each other. If a feature only has one switch or only one switch is available it will be displayed at the top of the two switch column.

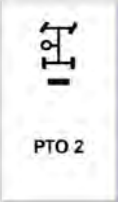
4.08.30 Optimized Idle

General Description, Optimized Idle

Optimized Idle reduces idle time by automatically stopping and restarting the engine. Besides saving fuel, it helps keep the batteries charged while maintaining engine and cab temperature.

The following conditions must be met for the optimized idle to function:

- Vehicle in neutral gear
- Parking brake set
- Hood latched
- Sleeper fan on

Optimized idle has four unique operating modes: battery, cold startability (engine oil temperature), interior comfort mode, keyless.

- Battery mode: starts the engine when battery voltage is below a certain threshold.
- Engine oil temperature mode: starts the engine when the engine oil temperature is below a certain threshold.
- Comfort mode: starts the engine to maintain the driver's selected interior temperature
- Keyless mode: maintains any of the modes above without the key in the ignition switch.

Optimized Idle Procedure

Optimized idle can be started with the engine running or the engine off.

1. With the key on, go to the Cab menu and select Optimized Idle. A caution notice will popup.
2. Read the caution and press Enable.
3. A screen may appear to start Standby or another mode. If this is the only option, press Enable.
4. Otherwise a screen will appear with an Enable with Comfort button as an option. If you want to optimize the environment of the sleeper section, select the Enable with Comfort button.
5. The vehicle will go into standby mode, an under hood alarm will briefly sound, and the engine will crank and achieve 900 rpm. The screen will change to the selected mode. A Disable button will be present.
6. The engine and fan/air conditioning will run until it achieves the temperature requested by the driver. The engine will then shut down.

Optimized idle can be shut off by ICUC controls or pressing the brake. If the sleeper fan is turned off, optimized idle will not shut down but the engine will.

4.08.31 Settings

The settings menu allows you to choose system features such as display language, units of measurement, and sound levels.

Tap on the settings (gear) icon in the lower left hand corner of the infotainment screen to access Settings. Settings can also be accessed under the Cab menu.

NOTE: Settings options will change based on the features installed on the vehicle.

Settings: Display Style

Adaptive Cruise Display is the only current feature for which display options are available.

Settings: Language

Language options currently include English (American), Français (Canadian), and Español (Mexican).

Settings: Units

NOTE: Setting a Distance unit to either imperial (miles) or metric (kilometers) will auto-populate the Consumption to the same system of measurement.

Units refers to units of measurement and are selected using an either/or radio buttons in each category.

Units are set for Speed (km/h or mph), Fuel Consumption (1/100km or mpg), and Distance (kilometers or miles). Other units include:

- Following Distance: either distance or time
- Pressure: either kPa or PSI
- Temperature: either Celsius or Fahrenheit

Settings: Brightness

Brightness levels for the instrument display, infotainment display, and the dash can be adjusted here using touch-screen slider controls.

Settings: Key Alert

This setting turns the audible lock alert on or off.

Settings: Display Off and On

Selecting this setting turns the display off. Touching anywhere on the display screen turns it on again.

Settings: Controls

Controls provides the ability to change keyboards to accommodate different languages and scripts as well as change the sensitivity levels of touch controls. Touch control settings include slow, medium, and fast.

Audible system feedback controls can also be accessed here as well as under audio settings.

Settings: Audio

Audio Settings control the volume of navigation and traffic announcements, audible system feedback, and phone ringtone and speech volume.

Audible system feedback setting choices include normal, loud, and off. All other audio settings provide touch-screen slider controls to set volume.

Settings: Licence Activation

License Activation lists all activated software licences with activation and expiration dates.

Settings: Reset

The Reset option under Settings allows you to delete all data from the system.

Driving Assistance Settings

The Driving Assistance menu is only available if at least one driving assistant setting is available.

The Driving Assistance menu in Settings allows you to turn available features on or off and/or change setting parameters.

Possible Driving Assistance menu options include:

- Side Guard Assist
- Active Lane Assist
- Traffic Sign Display
- eCoast
- Attention Assist
- Creep Mode

Driving assistance features are described in the chapter on **Driver Assistance Features** and the chapter on **Optional Engine Systems**.

4.08.32 Lighting

The lighting menu provides controls for a set of interior and exterior lights using the touch screen.

Exterior lighting

The exterior lighting screen presents an image of the front of the vehicle showing lights and digital switches for those lights. Touching a switch lights up the switch, activates the lights on the image of the truck, and turns on that light on the truck itself; touching the switch again turns all these lights off.

Touching the intelligent high-beam headlights control at the bottom of the screen will change its status. For this switch the status of On is indicated by a lighted bar at the top of the icon.

When intelligent high-beam headlights are on, the high-beam headlights will switch to low-beam headlights when a vehicle approaches from the opposite direction. They will switch back to high-beam headlights when no vehicles are approaching from the opposite direction.

The intelligent headlights can also be controlled by using the headlight switch and turn signal lever; see the chapter on **Driver Controls** for more information.

Touching the courtesy lighting icon will open a popup showing the current lighting duration and allowing the lighting duration to be adjusted.

Exterior lighting controlled by the rotary dial cannot be controlled through the exterior light screen.

If the fog lamp is turned on via the rotary dial, the fog lamp on the truck graphic will be shown as on.

Interior Lighting

The interior lighting menu shows an image of an interior of the vehicle. The digital switches for interior lighting allow for the control of overhead, foot well, and sleeper lights.

Touching any of the light icons on the screen will light up the digital switch, activate the lights on the interior image of the truck, and turn on those lights in the truck itself.

All interior lights can be dimmed using the slider next to the light icon.

All available lights in the cab can be turned off and on by touching the Off button.

Entrance lighting can be controlled by the settings icon. Touching the settings icon will open a popup window where the entrance lighting can be toggled off or on and entrance light timing controls can be accessed. Choosing entrance light timing will open a slider that allows modification of the length of time the entrance light is on.

All sleeper lights can be dimmed using the slider next to the light icon.

4.08.33 Climate Control Information

NOTE: See **Chapter 8** Climate Controls for detailed climate control panel operating instructions.

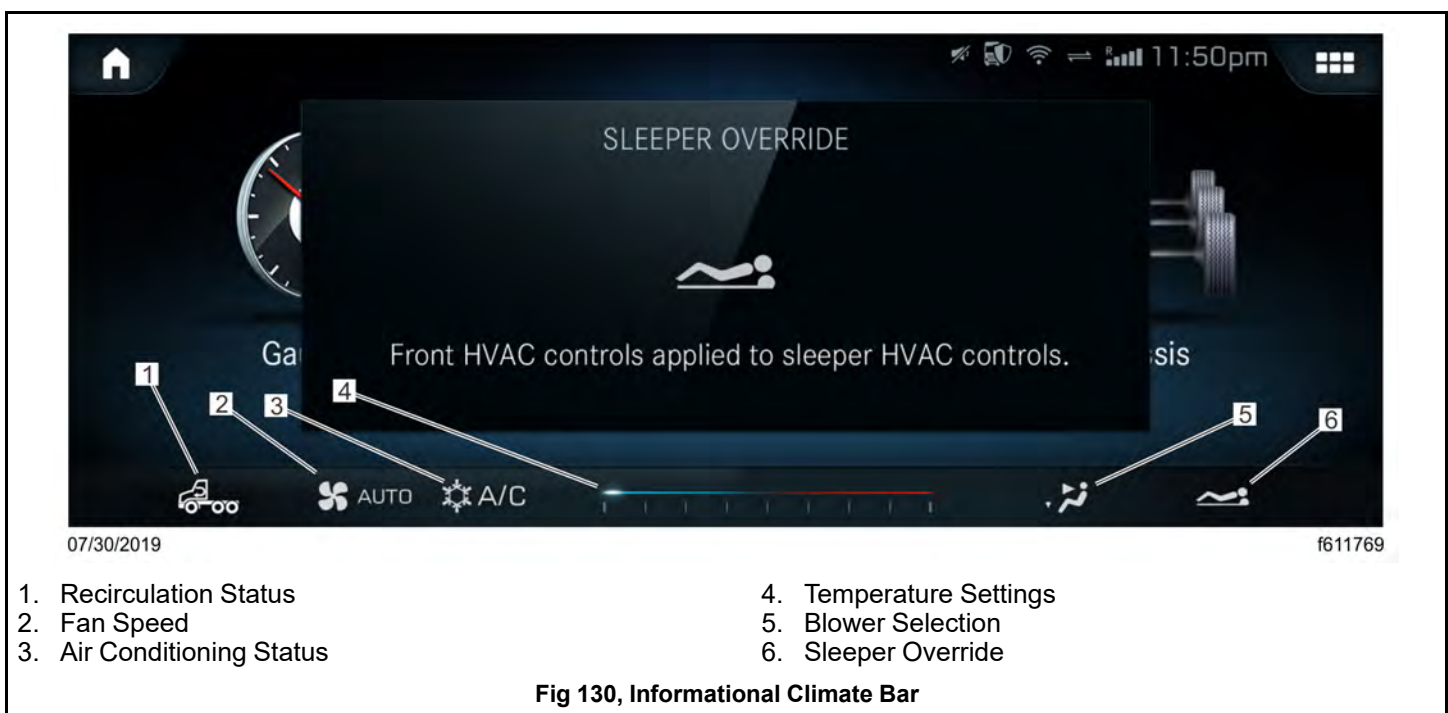

On vehicles equipped with the ICC5, climate control information will briefly appear on the B-panel display when physical climate controls are adjusted. The following controls should cause the climate bar to appear: recirculation settings, fan speed, air conditioning status, temperature setting, and blower selection.

If the cab is equipped with a sleeper and the sleeper override button is pressed, the sleeper override icon will also appear in the climate bar. In addition, changes to the climate control of the sleeper area will appear in a pop-up message.

4.09 Infotainment: ICC5

4.09.01 General ICC5 Infotainment Information

Information and controls available on the ICC5 infotainment (B-panel) display:

- Shortcut icons, statusline, and climate bar
- Gauges
- Cab
- Chassis
- Lighting
- Navigation
- Phone
- Radio
- Media
- Smartphone

4.09.02 System Settings

Select the gear icon to open the Settings menu. Settings is also available within the Cab menu.

System Settings lets you choose settings for driving assistance features, the system itself (language, units of measurement, etc.), and connectivity.

For more information see **Driver Display: ICC5** in this chapter.

Connectivity

Connectivity settings control the on or off status of the following features:

- Bluetooth
- NFC (Near Field Communication)
- Wi-Fi

Active and authorized devices will have an options menu (opened by selecting the three dots to the right of a device name) to manage device call logs, contacts, and deauthorization.

Up to two phones can be active and connected via Bluetooth.

Bluetooth

Bluetooth is a wireless technology standard for exchanging data over short distances, typically less than 33 feet (10 m).

A phone connected via Bluetooth will disconnect from the system when taken far enough away from the vehicle or turned off. It will automatically reconnect when in range of an active system if it has not been deauthorized.

Device Manager

Under the Device Manager menu you can:

- Connect a new device
- See a list of active and authorized devices
- Control transmission volume
- Control reception volume
- Deauthorize a device

The last three options can be accessed by selecting the three dots to right of the device name. Both the reception and transmission volume consist of a slider control with a range of -2 to 2.

4.09.03 Connecting and Disconnecting a Phone Using Bluetooth®

General Description

One can connect or authorize a mobile device such as a smartphone to interact with the ICC5 infotainment system through the Phone menu.

Up to fifteen mobile phones can be authorized at a time.

NOTE: The Smartphone menu is for connecting a device via MirrorLink®, Android Auto or Apple CarPlay.

Requirements:

- Bluetooth® is activated on the mobile phone.
- The phone is visible to Bluetooth®.
- Bluetooth® is activated on the infotainment system.

Activating Bluetooth®

NOTE: An iPhone may be connected to the infotainment system via Apple CarPlay.

1. Open Settings by selecting the gear shortcut icon in the lefthand corner of the screen.
2. Select Connectivity.
3. Make sure Bluetooth is turned on.
4. Make sure Bluetooth is active on the phone and the phone is visible via Bluetooth.

Connecting a Phone Using Bluetooth®

NOTE: Older phones may require that an authorization code be manually entered on the mobile phone and into the infotainment system.

1. Open the Device Manager.
2. Select Connect Device.
3. Select Connect New Device. The vehicle searches for the device.
4. If the connection fails, the message My Device Was Not Found will appear. Verify the Activating Bluetooth requirements have been met.
5. Select the My Device Was Not Found message or press the reload icon at the top right to have the vehicle rescan for devices.
6. When a device is found, the name of that device will appear on the screen in addition to the message My Device Was Not Found. Select the device name.
7. A pop-up will appear asking for verification of a passkey on the phone. Verify the passkey. The device is authorized and connected.

NOTE: The phone will automatically reconnect to the system when in range until deauthorized either in the ICC5 infotainment system or on the phone itself.

The Phone Menu

Once a phone is authorized and connected, a mobile phone menu for that phone is available.

In addition, the call list and contacts of the primary phone are loaded and accessible.

The phone menu provides a search function for the primary phone's contacts, a number pad for calling people not in the contact list, and access to Bluetooth and phone specific settings.

Connecting a Second Phone

Connecting a second phone follows the same process as connecting the initial phone, however the call list and contacts of the second phone are not loaded.

1. Open the Device Manager.
2. Select Connect Device.
3. Select Connect New Device. The vehicle searches for the device.
4. When a device is found, the name of that device will appear on the screen in addition to the message My Device Was Not Found. Select the device name.
5. A pop up will appear asking for verification of a passkey on the phone. Verify the passkey. The device is authorized and connected.

NOTE: The phone will now automatically reconnect to the system when in range until deauthorized either in the ICC5 infotainment system or on the phone itself.

Two Phone Mode

In two phone mode, the primary mobile phone can access the phone's contact and call list on the infotainment system and make outgoing calls and receive incoming calls; the secondary mobile phone can receive incoming calls.

Switching Primary and Secondary Phones

NOTE: When the secondary phone becomes the primary phone, that phone's contacts and call list are loaded into the system. The previous primary phone, now the secondary phone, has no data accessible on the system.

1. Open the Phone menu.
2. Select the icon showing two phones. The primary and secondary phone are switched.

Changing Phone Specific Settings

NOTE: You can only change phone functions on the primary mobile phone.

1. Open the Phone menu. The primary active phone's name should display in the upper left.
2. Select the gear icon to access the setting for the phone. The Options screen appears.
3. Choose which of the following options to change:
 - Synchronize Contacts Automatically
 - Synchronize contacts: this options is only available if Synchronize Contacts Automatically is turned off.
 - Delete Contacts: deletes all contacts downloaded from the active phone. Only available if Synchronize Contacts Automatically is turned off.
 - Delete Call List: deletes the call list downloaded from the active phone.
 - Name Format: names may be displayed as Last, First; Last First; or First Last.
 - Bluetooth: Access Device Manager to connect a new phone, deauthorize a phone, and control a phone's transmission and reception volume.

Disconnecting a Phone

A phone may disconnect from the system for the following reasons:

- It moves out of range

- It is shut off or otherwise loses power

NOTE: The phone should automatically reconnect when on and in range of an active system it is authorized to connect to. To cancel this automatic pairing, the phone must be deauthorized either on the system or on the phone.

Reconnecting a Phone

If a phone does not automatically reconnect to an authorized vehicle, do the following:

1. Open the Phone menu.
2. Select Connect Device or, if this is not available, select the Bluetooth icon. The Bluetooth Devices menu opens.
3. Find the phone under Authorized Devices and select the phone name. The vehicle will connect with the phone.

NOTE: if the connection fails, double check that Bluetooth is active on the phone and the phone is visible to Bluetooth.

Replacing a Phone

Replacing a mobile phone is the same process as connecting a phone.

To deauthorize the mobile phone being replaced, see **Deauthorizing a Phone Through the Phone Menu** in this chapter.

Deauthorizing a Phone Through the Phone Menu

Deauthorizing a mobile phone, either the primary or secondary phone, can be done in via the Phone menu or through system Settings.

1. Open the Phone menu.
2. Select the Bluetooth icon at the bottom of the screen. The Bluetooth Devices menu opens showing a list of active and authorized phones.
3. If necessary, swipe down the screen to see a list of all authorized devices.
4. Select the three dots to the right of the phone to deauthorize. The list of options available for that phone displays.
5. Select Deauthorize. The system asks for verification.
6. Select Yes. The phone is deauthorized.

Deauthorizing a Phone Through Settings

Deauthorizing a mobile phone, either the primary or secondary phone, can be done in via the Phone menu or through Settings.

1. Open the Settings menu by selecting the shortcut icon of a gear in the lower left corner. The system settings menu opens.
2. Select Connectivity. The Wi-Fi & Bluetooth menu opens.
3. Select Device Manager. The Bluetooth Devices menu opens showing a list of active and authorized phones.
4. Select the three dots to the right of the phone to deauthorize. The list of options available for that phone opens.
5. Select Deauthorize. The system asks for verification.
6. Select Yes. The phone is deauthorized.

4.09.04 Using a Mobile Phone

General Phone Information

Calls may disconnect in the following situations:

- Insufficient network coverage

- Lack of free voice channels when you travel into a new transmitter/receiver area (cell)
- Phone SIM card is not compatible with the available network
- The second SIM card of a Twincard mobile phone is already logged onto the network

In addition, voice quality may fluctuate. The infotainment system supports high quality calls in HD Voice®, but this depends on HD Voice® being supported by both the mobile phone in use and the network.

Setting Reception and Transmission Volume

NOTE: A phone must be active to access these settings.

This setting helps ensure optimal speech reception and transmission quality.

1. Open the Phone menu.
2. Select the Bluetooth icon. The Bluetooth Devices menu opens.
3. Select the three dots to the right of the phone to access that phone's options.
4. Select Reception Volume and set the volume.
5. Select the back arrow.
6. Select Transmission Volume and set the volume.
7. Return to the main phone screen by pressing the back arrow or selecting the physical phone button at the bottom of the infotainment screen.

Searching for a Contact and Making a Call

NOTE: A phone must be active to access these settings.

1. Open the Phone menu.
2. Select the magnifying glass icon for Search. A keyboard opens.
3. Start entering the first or last name of a contact or a partial or full phone number. As you type a number will appear next to the icon for the results list showing how many phone contacts have that series of characters.
4. When the number is small enough, select the results list icon to the right of the search box. A results list appears.
5. Select the desired contact. The contact card appears.
6. Select the desired contact phone number. A call is placed.

Starting Phone Voice Recognition

NOTE: When in two phone mode, the phone voice recognition is only available on the primary phone.

Press and hold the Voice button on the right-hand OFN steering wheel pod for at least one second. Phone voice recognition is now available.

Ending Phone Voice Recognition

Press either the Mute Volume or End Call button on the right-hand OFN steering wheel pod. Mobile phone voice recognition has ended.

Making a Call

1. Open the Phone menu. The primary phone menu appears.
2. Select the number pad icon or select Contacts or Call List menu.
 - 2.a If using the number pad, enter a number. Select the green phone receiver icon. The call is made.
 - 2.b If using the Contact's menu, select a contact. The contacts information is shown. Select a phone number. The call is made.

2.c If using the Call List menu, select the phone number. The call is made.

Accepting a Call

There are two ways to accept a call:

- Press the Accept Call button on the right-hand OFN steering wheel pod.
- Select the accept call button on the infotainment screen.

Ending or Rejecting a Call

There are two ways to end or reject a call:

- Press the End Call button on the right-hand OFN steering wheel pod.
- Press the end call button on the infotainment screen.

Putting an Active Call on Hold and Taking it Off Hold

The function and behavior of taking calls on and off hold and accepting and rejecting waiting calls can vary depending on the phone, phone plan, and network provider. If functions and behavior vary from these directions, consult the manufacturer's operating instructions and provider information.

NOTE: A call on hold can be ended by selecting the End Call button on either the right-hand OFN steering wheel pod or the infotainment screen.

1. Select the active call number. The call is put on hold.
2. Select the active call number. The call is taken off hold.

Accepting a Waiting Call in Single Phone Mode

If there is an incoming call while a call is being conducted, a screen notification is shown. Depending on the mobile phone and network provider, you may also hear a sound.

Tap on the Accept Call button on either the right-hand OFN steering wheel pod or the infotainment screen. The waiting call is now active. The previous call has been put on hold.

Accepting a Waiting Call in Two Phone Mode

If two phone mode is active and the second call is incoming on the secondary phone, you may hear a signal in addition to getting a screen notification and hearing a sound.

NOTE: Accepting a incoming waiting call on the secondary phone while in two phone mode with a call on hold on the primary phone, will end the active call on the secondary phone.

Tap on the Accept Call button on either the right-hand OFN steering wheel pod or the infotainment screen. The waiting call is now active. The previous call has been on hold.

Switching Between Calls

If there is an active call and another call connection has been established, there are two ways to switch back and forth between calls:

- Select the Switch Calls icon of two arrows pointed in opposite directions on the infotainment screen.
- Select the waiting call. The active call is put on hold. The chosen call is active.

NOTE: On some mobile phones, ending the active call will automatically take the call waiting off hold.

Functions Available During a Call

The following functions are available during an active call:

- The microphone: selecting the microphone turns it on or off.
- The number pad: can be used to send Dual Tone Multiple Frequency (DTMF) tones.

- The Transfer to Phone icon: transfers an active hands-free call over to the phone.

4.09.05 Phone Contacts and Call List

Importing Phone Contacts

Phone contacts of the primary phone are automatically imported when a phone is initially connected to the system.

NOTE: Deleting all contacts and turning off Synchronize Contacts Automatically without deauthorizing the phone will cause the phone to reconnect to the system without re-importing the contacts list.

Changing the Format of Contacts' Names

NOTE: This does not change the format of contacts' names on the phone.

1. Open the Phone menu.
2. Select the gear icon on the bottom of the primary phone's screen. The Options menu opens.
3. Select Name Format. Three name formats appear: Last Name, First Name; Last Name First Name; First Name Last Name.
4. Select the radio button for your choice of name format. The format of the names in the phone contact list is changed.

Turning Off Synchronizing Phone Contacts

Default system behavior is to have contacts on the primary phone automatically synchronize.

1. Open the Phone menu.
2. If in two phone mode, make sure the phone you want to synchronize is the primary phone.
3. Select the gear icon at the bottom of the phone screen. The Options menu opens.
4. Move the radio button to turn off Synchronize Contacts Automatically. Contacts will no longer be synchronized for this phone.

Deleting All Contacts for the Primary Phone

NOTE: A phone must be connected to the infotainment system to access these settings.

Deleting all contacts for the primary phone does not delete the contacts off the phone nor does it delete any of the contacts saved to Favorites. The contacts saved to Favorites can still be accessed and used from the Favorites menu as long as the phone is connected to the infotainment system.

Deauthorizing the phone also does not delete any contacts saved to the Favorites menu. They do, however, become unavailable for use.

Synchronize Contacts Automatically must be turned off to delete contacts. As long as Synchronize Contacts Automatically remains off, the phone can disconnect and reconnect to the system without contacts being reloaded.

1. Open the Phone menu.
2. Select the gear icon on the bottom of the screen for the connected phone. The Options menu opens.
3. Turn off Synchronize Contacts Automatically.
4. Select Delete Contacts. A message asking for verification appears.
5. Select Yes. All contact data for the primary phone is deleted off the infotainment system except for contacts saved to Favorites.

Deleting a Phone's Call List

NOTE: A phone must be connected to the infotainment system to access these settings.

Deleting the call list from the infotainment system does not delete the call list off the phone.

If a phone disconnects and then reconnects to the infotainment system, the phone call list will be reloaded.

1. Open the Phone menu.
2. Select the gear icon on the bottom of the screen for the connected phone. The Options menu opens.
3. Select Delete Call List. A message asking for verification appears.
4. Select Yes. The call list for the primary phone is deleted.

Saving a Contact as a Favorite

NOTE: A phone must be connected to the infotainment system to access these settings.

1. Open the Phone menu. The screen for the primary phone appears.
2. Open the Contacts. The phone's list of contacts appears.
3. Select the contact you want to add to the Favorites menu.
4. Press and hold on the phone number. The Options menu for the contact appears.
5. Select Create new favorite. A favorite is created.

Saving a Call List Number as a Favorite

1. Open the Phone menu. The screen for the primary phone appears.
2. Open the Call List. The phone's call list appears.
3. Press and hold the phone number you want to add to the Favorites menu. The Options menu for the number appears.
4. Select Create new favorite. A favorite is created.

Renaming a Phone Favorite

1. Select the star shortcut icon to open the Favorites menu.
2. Press and hold on an individual favorite. The Options menu for the favorite will open.
3. Select Rename. A keyboard will appear.
4. Type in the new name for the favorite. Select OK. The favorite has been renamed.

Moving a Phone Favorite

The order of the favorites menu can be changed to place frequently accessed favorites on the first screen.

1. Select the star shortcut icon to open the Favorites menu.
2. Press and hold on an individual favorite. The Options menu for the favorite will open.
3. Select Move. The favorites screen will change appearance. A check mark will appear over the chosen favorite and arrows will appear on each side of it.
4. Press on the arrows to move the favorite to either the left or right until it's in the chosen position.
5. Select the check mark on top of the favorite. The favorite's new position is saved.

Deleting a Phone Favorite

1. Select the star shortcut icon to open the Favorites menu.
2. Press and hold on an individual favorite. The Options menu for the favorite will open.
3. Select Delete. The favorite is deleted.

Deleting All Phone Favorites

NOTE: If you delete the phone's contact list, none of the contacts saved to the Favorites menu will be deleted. The only way to delete all phone contacts saved to the Favorites menu is to delete each phone contact favorite individually or reset the Favorites menu.

4.09.06 Radio

General Description Radio

NOTE: It is a standard safety feature for the radio to mute during safety related events; starting in June 2021 Pana-Pacific/Aptiv radios installed in Freightliner vehicles will automatically mute when the vehicle is in reverse gear.

Opening the Radio icon opens the radio home screen with four options across the top: SiriusXM, FM, AM, and WX.

Searching for an AM/FM Radio Station

NOTE: Searching for an AM/FM radio stations by name is not currently available.

1. Select either FM or AM at the top of the Radio menu.
2. Select the magnifying glass icon. A keyboard with a search bar opens.
3. Press the 123 to access the number pad. The keyboard changes to numbers and symbols.
4. Enter the first two or three digits of the desired station frequency ID. The number of results shows next to the results list icon to the right.
5. Select the results list icon. A list of radio frequencies displays, i.e. 89.0 MHz, 89.1 MHz, 89.2 MHz, etc.
6. Select the desired frequency. The radio is set to that frequency.

NOTE: Selecting the arrows to the left of the station icon identification or album artwork will page through the different stations available, in any, at this frequency.

SiriusXM® Radio

Search options include searching for a station by name, category, or browsing the complete list of available stations.

Searching for a SiriusXM® Satellite Radio Stations by Name

1. Select SiriusXM at the top of the Radio menu.
2. Select the magnifying glass icon. A keyboard with a search bar appears.
3. Start typing the name of a known station. The number of stations with that word appears to the right next the results list icon.
4. Select the results list icon. The list of results appears.
5. Select a station. The station starts playing.

Searching for a SiriusXM® Satellite Radio Station by Category

1. Select SiriusXM at the top of the Radio menu.
2. Select the list icon at the bottom of the screen. The SiriusXM menu opens.
3. Select Category. A list of station categories appears.
4. Select the desired category. The Category list of stations in that category appears.
5. Select a station. The station starts playing.

Browsing SiriusXM® Satellite Radio Stations

1. Select SiriusXM at the top of the Radio menu.
2. Select with the list icon at the bottom of the screen. The SiriusXM menu opens.
3. Select SiriusXM. A current station/channel list appears.
4. Select the desired station. The station starts playing.

Adding a Radio Channel to Favorites

Up to twenty different items can be saved to the Favorites menu.

1. Open the Radio icon.
2. Navigate to the desired radio station.
3. Press and hold on the station icon or current album artwork. The Options menu will open.
4. Select Save as Favorite. The station is now a favorite.

Deleting a Radio Station Favorite

NOTE: While Global Favorites are created inside individual applications, they are deleted, moved, or renamed inside the Global Favorites menu. For directions, please see the **Favorites** section in this chapter.

Setting a Radio Station Preset

The infotainment system can save up to 12 radio presets.

1. Open the Radio icon.
2. Navigate to the desired radio station.
3. Press and hold on the station icon or current album artwork. The Options menu will open.
4. Select Add to presets. The station is now a preset.

Saving a Radio Station Preset as a Favorite

A radio station can be saved as both a preset and a favorite.

1. Open the Radio icon.
2. Use the arrows to the right and left of the screen to navigate to the desired preset.
3. Press and hold on the preset. The Options menu opens.
4. Select Save as Favorite. The preset is now also saved under the Favorites menu.

Moving a Radio Preset

Radio station presets can be reordered to move those more frequently accessed to the first screen.

1. Open the Radio icon.
2. Use the arrows to the right and left of the screen to navigate to the desired preset.
3. Press and hold on the preset. The Options menu opens.
4. Select Move. A checkmark appears over the preset with arrows to each side.
5. Press the arrows to move the preset into the desired order.
6. Select the checkmark over the preset. The preset is now saved in its new location.

Deleting a Radio Preset

1. Open the Radio icon.
2. Use the arrows to the right and left of the screen to navigate to the desired preset.
3. Press and hold on the preset. The Options menu opens.
4. Select Delete. The preset is now deleted.

Weather Radio (WX)

Weather Radio displays as WX in the top radio menu.

Weather radio channels WX1 through WX7, corresponding to frequencies 162.400 MHz through 162.550 MHz, are the standard weather radio channels used by NOAA Weather Radio in the United States, Weatheradio Canada/Radiométéo Canada in Canada, and SARMEX in Mexico. Each system consists of a nationwide network of radio stations broadcasting official weather warnings, watches, advisories, forecasts and other non-weather related hazard information including news on natural disasters (earthquakes, avalanches, floods), environmental hazards (oil spills, chemical releases), and public safety messages (AMBER alerts, network outages). All services operate 24 hours a day, 7 days a week.

The average range for reception from a transmitter is approximately 40 miles (60 km). The National Weather Service operates more than 1000 transmitters.

Displaying AM/FM/WX Emergency Warnings

1. Select the gear icon at the bottom of the AM, FM, or WX radio screen. The Options menu for that application opens.
2. Turn on or off Display Emergency Warnings.

4.09.07 Sound System Settings

Adjusting the Volume

Volume can be increased or decreased by pressing the VOL or +VOL buttons below the infotainment screen or by using the VOL+ or VOL buttons on the OFN steering wheel switch pod.

Muting and Unmuting the Radio

The global Radio menu has an icon of a speaker with a line through it. Press this icon to mute the radio. The radio mutes. The icon image changes to a speaker playing music.

To unmute the radio select the icon of the speaker playing music. The radio starts playing. The icon image changes to a speaker with a line through it.

Muting and Unmuting Media Devices

To mute or unmute audio playback from media devices you can increase or decrease the volume or halt media playback.

Play of media devices can be halted via the Media menu by selecting the pause button. Restarting media playback may be done by selecting the play button the Media menu.

Bluetooth streaming may require restarting playback on the connected device.

4.09.08 Favorites

General Description

The Favorites menu offers quick access to frequently used phone numbers and radio stations. It can be accessed by selecting the star shortcut icon at the bottom right of the infotainment screen.

Favorites are created from inside different applications. For directions on saving a phone contact to the Favorites menu, see **Saving a Contact as a Favorite** in this chapter. For directions on saving a radio station to the Favorites menu, see **Adding a Radio Channel to Favorites** in this chapter.

It is possible to create up to twenty favorites.

Renaming Favorites

1. Tap on the star shortcut icon to open the Favorites menu. Saved favorites are displayed.
2. Press and hold on the icon for a favorite. The Options menu appears.
3. Select Rename. A keyboard appears.
4. Enter the new name. Select OK. The favorite has been renamed.

Moving Favorites

Favorites can be reordered to move the most popular to the first screen of the Favorites menu.

1. Tap on the star shortcut icon to open the Favorites menu. Saved favorites are displayed.
2. Press and hold on the icon for a favorite. The Options menu appears.
3. Select Move. The selected favorite now has a checkmark over it and arrows at each side.
4. Press on either the right or left arrow to move the favorite into the desired position.
5. Select the checkmark. The favorite has been saved in its new position.

Deleting Favorites

1. Tap on the star shortcut icon to open the Favorites menu. Saved favorites are displayed.
2. Press and hold on the icon for a favorite. The Options menu appears.
3. Select Delete. The favorite is now deleted.

4.09.09 Media

General Description

The vehicle infotainment system is capable of playing music from a phone, USB drive, or other device. The vehicle has two USB2 ports to connect devices. Devices can also be connected to the system via Bluetooth.

If an authorized phone is connected to the system via Bluetooth when the Media menu is opened, the infotainment system should automatically start streaming that music.

Playing Audio Off a Phone or Other Device

Selecting a different audio source than the one active turns off the music. You may need to restart the music on the device when returning to the original audio source to get the music to play.

NOTE: Bluetooth audio functions are not available if an Apple CarPlay, Android Auto, or MirrorLink session is active.

1. Open the Media menu.
2. Select the audio source: Bluetooth, USB1, or USB2.
3. If necessary, select the music to play. Music starts playing through the vehicle speakers.

4.09.10 Smartphone

NOTE: Apple CarPlay, Android Auto, and MirrorLink should **not** be used for navigation for a truck or bus as both lack the ability to take vehicle-based route restrictions into account.

Apple CarPlay

Apple CarPlay allows a driver to use an iPhone to make calls, send and receive messages, listen to music, and get directions.

Apple CarPlay can connect to the system via a USB2 cable or Bluetooth.

Android Auto

Android Auto allows the driver to use an Android phone to make calls, send and receive messages, get information, listen to music, and get directions.

Android Auto requires that a smartphone be connected to the system via a USB2 cable.

MirrorLink®

MirrorLink allows a driver to use any MirrorLink enabled smart phone to get directions, listen to music, and use smart phone applications.

MirrorLink uses huge icons that allow for the control of smart phone features without getting distracted from the task of driving.

4.10 Warnings, Indicators, and Messages

4.10.01 Audible Alerts: ICUC

An audible alert sounds whenever one of the following conditions exists:

- Engine oil pressure falls below the minimum preset value.
- Coolant temperature rises above the maximum preset value.
- Air pressure falls below approximately 70 psi (483 kPa).
- Parking brake is set with the vehicle moving faster than 2 mph (3 km/h).
- System voltage falls below 11.9 volts.
- Door is unlatched with the parking brake off.

Optional audible alert sounds whenever one of the following conditions exists:

- Driver seat occupancy sensor reads someone in the seat with the seat belt not fastened and the parking brake off.
- Key is in the ignition and the door is unlatched.

4.10.02 Audible Alerts: ICC5

An audible alert sounds whenever one of the following conditions exists:

- Engine oil pressure falls below the minimum preset value.
- Coolant temperature rises above the maximum preset value.
- Air pressure falls below approximately 70 psi (483 kPa).
- Parking brake is set with the vehicle moving faster than 2 mph (3 km/h).
- System voltage falls below 11.9 volts.
- Door is unlatched and the vehicle speed exceeds 5 mph (8 km/h).

Optional audible alert sounds whenever one of the following conditions exists:

- Driver seat occupancy sensor reads someone in the seat with the seat belt not fastened and the parking brake off.
- Key is in the ignition and the door is unlatched.

4.10.03 Warnings, Indicators, and Messages

Warning and indicator lights (telltales) with icon symbols are displayed on the physical dashboard and on ICU screens. The positions of the telltales and warnings vary, but most telltale symbols are standard. See the below tables for a listing of different warnings and telltales in addition to messages and popup screens.

The colors of telltales and warnings indicate the hazard level: red (warning), amber (caution), green and blue (active status), grey (passive status), white (informational). Blue is currently used to indicate an active phone call, that a software download is available, and that utility lamps and high beams are on.

IMPORTANT: Depending upon local jurisdictional emissions guidelines, vehicles and/or engines that are domiciled outside of the U.S. and Canada may not be compliant with EPA10 or GHG21 regulations. Noncompliant vehicles may not be equipped with all of the telltales shown in the below tables.







| Warnings, Indicators, and Messages — Engine System | | | | |
|---|-------|--------------------------------|--|---|
| Telltale | Color | Description | | Related Messages |
|  | Red | Stop Engine* | Indicates a serious fault that requires engine shutdown immediately. The engine protection system will reduce the maximum engine torque and speed, and, if the condition does not improve, will shut down the engine within 30 to 60 seconds. Safely bring the vehicle to a stop on the side of the road and shut down the engine as soon as the red light is seen. If the engine shuts down while the vehicle is in a hazardous location, turn the key to the OFF position for a few seconds, then restart the engine and move the vehicle to a safer location. | Various |
|  | Red | Engine Oil Level Warning | | |
|  | Red | Low Engine Oil Pressure | Indicates the engine oil pressure is below the minimum allowable pressure. |  ICUC Warning |
|  | Red | Engine Oil Temperature Warning | | |
|  | Red | Low Coolant Level | | |

Table 9, Engine Related Indicators









| Warnings, Indicators, and Messages — Engine System | | | | |
|---|-------|--|---|---|
|  | Red | High Coolant Temperature | Indicates the coolant temperature is above the maximum allowable temperature. |  <p>04/22/2016 f611371</p> <p>ICUC Warning</p> |
|  | Amber | Check Engine* | Indicates an engine condition (low oil pressure, low coolant level, high coolant temperature, high DPF soot level, uncontrolled DPF regeneration, or battery voltage 11.9 volts or less) that requires correction. Correct the condition as soon as possible. If the condition worsens, the STOP engine lamp will illuminate. | Various |
|  | Amber | Engine Malfunction Indicator Lamp (MIL)* | A steadily illuminated amber MIL lamp indicates an engine fault that effects emissions. | |
|  | Amber | Engine Malfunction Indicator Lamp (MIL)* | Alternate Engine Malfunction Indicator lamp. A steadily illuminated amber MIL lamp indicates an engine fault that effects emissions. | |
|  | Amber | Engine Oil Level Caution | | |
|  | Amber | Engine Oil Pressure Caution | | |
|  | Amber | Low Coolant Level Caution | | |
|  | Amber | High Coolant Temperature Caution | | |

Table 9, Engine Related Indicators





| Warnings, Indicators, and Messages — Engine System | | | | |
|---|-------|-----------------------|--|--|
|  | Amber | Start Blocked | Indicates that the system is preventing the starter from cranking. This can occur when the ignition switch is turned to START before the gauge sweep has completed. Display of the Start Blocked screen does not indicate a problem with the starter. Turn the ignition switch back to ON, wait for the message to turn off, then turn the ignition switch to START again. |  ICUC Notice |
|  | Amber | Start Blocked | Alternative Telltale for Start Blocked. | |
|  | Green | Start Engine | | |
|  | Green | Optimized Idle Active | Indicates optimized idle is active. | |

Table 9, Engine Related Indicators

*See Chapter 14 **Emissions and Fuel Efficiency** for an explanation of the Aftertreatment System (ATS) warning indicators, and actions required to avoid further engine protection steps.



| Telltale, Indicator Icons, and Messages — Transmission | | | | |
|---|-------|----------------------------------|---|------------------|
| Telltale | Color | Description | | Related Messages |
|  | Red | Transmission Fluid Level Warning | Indicates low transmission fluid level. Safely bring the vehicle to a stop as soon as possible. | |
|  | Amber | Caution Check Transmission | Indicates an undesirable transmission condition. | |

Table 10, Transmission Related Indicators



| Telltale, Indicator Icons, and Messages — Transmission | | | | |
|---|-------|--------------------------------------|---|---|
|  | Amber | Low Transmission Fluid Level Caution | Indicates low transmission fluid level. | |
|  | Amber | High Transmission Temperature | Indicates transmission is overheating. |  04/22/2016 f611377 ICUC Caution |

Table 10, Transmission Related Indicators





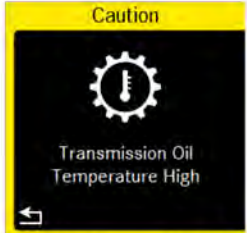

| Telltale, Indicator Icons, and Messages — Brakes | | | | |
|---|-------|--|---|---|
| Telltale | Color | Description | | Related Messages |
|  | Red | Low Brake Air Pressure (EPA10 and Newer) | Indicates air pressure in the primary or secondary reservoir has dropped below approximately 70 psi (483 kPa). | |
|  | Red | Low Brake Air Pressure (EPA10 and Newer) | Alternate low brake air pressure telltale. Indicates air pressure in the primary or secondary reservoir has dropped below approximately 70 psi (483 kPa). |  06/30/2016 f611429 ICUC Warning |
|  | Red | Parking Brake Engaged (EPA10 and Newer) | Indicates the parking brake is engaged. | |
|  | Red | Parking Brake Engaged (EPA10 and Newer) | Alternative icon indicating the parking brake is engaged. | |
|  | Amber | Hill Start Aid Disengaged | A blinking telltale indicates hill start aid is inactive. | To turn on HSA, press the HSA OFF switch again or restart the vehicle. |

Table 11, Brake Related Indicators





| Telltale, Indicator Icons, and Messages — Brakes | | | | |
|---|-------|------------------------------|---|--|
| | | | A solid telltale indicates a fault with the system. | |
|  | Amber | Winch Brake Caution | | |
|  | Amber | Work Brake Caution | | |
|  | Green | Descent Control Mode Engaged | | |
|  | Green | Engine Brake Engaged | Indicates the engine brake is enabled. | |

Table 11, Brake Related Indicators





| Telltale, Indicator Icons, and Messages — Driving Safety | | | | |
|---|-------|---|--|------------------|
| Telltale | Color | Description | | Related Messages |
|  | Amber | Electronic Stability Control (ESC) Active | Flashing indicates a stability event has been detected, and the ESC system is active. Solid illumination indicates a problem with the stability system. Repair the ESC system immediately to ensure full stability capability. | |
|  | Amber | Electronic Stability Program Off | | |
|  | Amber | Tractor Anti-Lock Braking System (ABS) | Momentary illumination indicates the vehicle ABS is engaged. Solid illumination indicates a problem with the vehicle ABS. Repair the ABS immediately to ensure full braking capability. | |
|  | Amber | Trailer Anti-Lock Braking System (ABS) | Momentary illumination indicates the trailer ABS is engaged. Solid illumination indicates a problem with the trailer ABS. | |

Table 12, Driving Safety Related Icons









| Telltale, Indicator Icons, and Messages — Driving Safety | | | | |
|--|-------|---|--|---|
| | | | Repair the ABS immediately to ensure full braking capability. | |
|  | Amber | Active Brake Assist Active | Indicates Active Brake Assist is engaged. | |
|  | Amber | Active Brake Assist Unavailable (GHG14 and newer) | Indicates the Active Brake Assist system is not available. |  <p>04/22/2016 f611353</p> <p>ICUC Caution</p> |
|  ICC5 Telltale | Amber | Lane Departure Unavailable | Indicates that lane departure warning is disabled due to minimum speed, lack of lane markings, or system not being available. Only on vehicles equipped with Detroit Assurance radar. | |
|  ICUC Telltale | Amber | Lane Departure Unavailable | Indicates that lane departure warning is disabled due to minimum speed, lack of lane markings, or system not being available. Only on vehicles equipped with Detroit Assurance radar. |  <p>06/28/2016 f611372</p> <p>ICUC Caution</p> |
|  ICC5 Telltale | Amber | Adaptive Cruise Control Not Available | Indicates that Adaptive Cruise Control (ACC) is not available Only on vehicles equipped with a radar-based collision warning and mitigation system (CWS/ CMS). | |
|  ICUC Telltale | Amber | Adaptive Cruise Control Not Available | Indicates that Adaptive Cruise Control (ACC) is not available Only on vehicles equipped with a radar-based collision warning and mitigation system (CWS/ CMS). |  |

Table 12, Driving Safety Related Icons

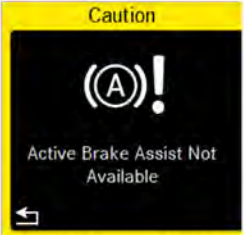





| Telltale, Indicator Icons, and Messages — Driving Safety | | | | |
|---|-------|-------------------------------------|---|--|
| | | | | ICUC Caution If ACC is not available, Active Lane Assist (ALA) will not be available. |
|  | Amber | IPPCC Error | | |
|  | Green | Adaptive Cruise Control Active | | |
|  | Red | Adaptive Power Steering (APS) Error | | An error with APS deactivates Active Lane Assist (ALA). |
|  | Blue | Lane Keep Assist (LKA) Active | LKA is a component of Active Lane Assist (ALA) along with Lane Departure Protection (LDP). If Adaptive Cruise Control (ACC) is not available, ALA will not be available. | This is also the Switch icon |
|  | Grey | Lane Keep Assist (LKA) on Standby | | When LKA is OFF there is no steering wheel icon |
|  | Amber | Gear Teach Mode in Progress | | |
|  | Green | AERO active | Indicates that aerodynamic height control (AERO) is active. | |

Table 12, Driving Safety Related Icons







| Telltale, Indicator Icons, and Messages — Suspension | | | | |
|---|-------|---|---|---|
| Telltale | Color | Description | | Related Messages |
|  | Amber | Suspension Higher Than Normal Ride Height / Axle Lifted | Indicates the current rear suspension height is above the normal ride height. |  11/09/2016 f611471 ICUC Caution |
|  | Amber | Suspension Lower Than Normal Ride Height / Axle Dropped | Indicates the current rear suspension height is below the normal ride height. |  06/29/2016 f611434 ICUC Caution |
|  | Amber | Suspension Height | | |
|  | Amber | Electronically Controlled Air Suspension (ECAS) Error | Indicates Electronically Controlled Air Suspension (ECAS) active fault. |  04/22/2016 f611367 ICUC Caution |

Table 13, Suspension Related Indicators



| Telltale, Indicator Icons, and Messages — Suspension | | | | |
|---|-------|------------------|---|---|
|  | Amber | Load Transfer | Indicates the ECAS system is applying the maximum available vehicle load on the drive axle up to the maximum gross axle weight rating (GAWR). |  ICUC Caution |
|  | Amber | 5th Wheel Adjust | | |

Table 13, Suspension Related Indicators



| Telltale, Indicator Icons, and Messages — Battery | | | | |
|---|-------|------------------|--|------------------|
| Telltale | Color | Description | | Related Messages |
|  | Red | Battery Critical | | |
|  | Red | Battery Failure | | |
|  | Amber | Battery Failure | | |

Table 14, Battery-Related Indicators



| Telltale, Indicator Icons, and Messages — Tires and ATC | | | | |
|---|-------|---------------------------|---|--|
| Telltale | Color | Description | | Related Messages |
|  | Red | Low Tire Pressure Warning | Indicates a notable loss of tire pressure in at least one tire. | If a tire monitoring system is available, the tire(s) with low pressure will be highlighted red. |
|  | Amber | Low Tire Pressure Warning | Indicates low tire pressure in at least one tire. | If a tire monitoring system is available, the tire(s) with low pressure will be highlighted amber. |

Table 15, Tire-Related Indicators



| Telltale, Indicator Icons, and Messages — Tires and ATC | | | | |
|---|-------|---|--|---|
|  | Amber | Automatic Trac-tion Control (ATC) Active | Flashing indicates a wheel spin event has been detected, and the ATC system is active. | |
|  | Amber | Automatic Trac-tion Control (ATC) Deactivated | Indicates the ATC SPIN button has been pressed to allow wheel slip. |  <p>ICUC Caution</p> |

Table 15, Tire-Related Indicators



| Telltale, Indicator Icons, and Messages — Fuel | | | | |
|---|-------|-----------------------|---|------------------|
| Telltale | Color | Description | | Related Messages |
|  | Amber | Low Fuel | Indicates low fuel level. Refill the main fuel tank. | |
|  | Amber | Water in Fuel Warning | Indicates the fuel may contain water. Drain any water collected in the fuel/water separators. | |

Table 16, Fuel-Related Indicators



| Telltale, Indicator Icons, and Messages — DEF and DPF | | | | |
|---|-------|------------------------------------|---|---|
| Telltale | Color | Description | | Related Messages |
|  | Red | Diesel Particulate Filter Critical | Indicates a parked regen is required immediately. |  <p>ICUC Warning</p> |

Table 17, Diesel Exhaust Fluid (DEF) and Diesel Particulate Filter (DPF)-Related Icons







| Telltails, Indicator Icons, and Messages — DEF and DPF | | | | |
|---|-------|--|--|---|
|  | Amber | Diesel Particulate Filter (DPF) Status | <p>Solid illumination indicates a regen is required. Change to a more challenging duty cycle (such as highway driving) to raise exhaust temperatures for at least twenty minutes, or perform a parked regen.</p> <p>Blinking indicates that a parked regen is required immediately. An engine derate and shutdown will occur.</p> |  <p>06/10/2016 f611401</p> <p>ICUC Caution</p> |
|  | Amber | Diesel Particulate Filter Inhibited | | |
|  | Green | Diesel Particulate Filter Regeneration in Progress | Indicates a regen is in progress. | |
|  | Amber | High Exhaust System Temperature (HEST)* | <p>Slow (10-second) flashing indicates a regeneration (regen) is in progress.</p> <p>When the HEST lamp is illuminated, do not park the vehicle near objects that can be harmed by high temperatures or flammable materials.</p> <p>Solid illumination indicates high exhaust temperatures at the outlet of the tail pipe when speed is below 5 mph (8 km/h).</p> | |
|  | Amber | Low Diesel Exhaust Fluid | <p>Indicates low diesel exhaust fluid.</p> <p>Fill the DEF tank.</p> | See Chapter 15, Emissions and Fuel Efficiency , for an explanation of the Aftertreatment System (ATS) warnings, and actions required to avoid further engine protection steps. |
|  | Amber | Low Diesel Exhaust Fluid | <p>Alternative icon to indicate Low Diesel Exhaust Fluid.</p> <p>Fill the DEF tank.</p> | See Chapter 15, Emissions and Fuel Efficiency , for an explanation of the Aftertreatment System (ATS) warnings, and actions required to avoid further engine protection steps. |

Table 17, Diesel Exhaust Fluid (DEF) and Diesel Particulate Filter (DPF)-Related Icons











| Telltale, Indicator Icons, and Messages — Lamps | | | | |
|---|-------|--------------------------|--|------------------|
| Telltale | Color | Description | | Related Messages |
|  | Green | Right-Turn Indicator On | Flashing indicates the outside right-turn signal lamps are activated. | |
|  | Green | Left-Turn Indicator On | Flashing indicates the outside left-turn signal lamps are activated. | |
|  | Blue | High-Beams On | Indicates the high-beam headlights are on. | |
|  | Green | Low-Beams On | Indicates the low-beam headlights are on. | |
|  | Blue | Automatic High-Beams On | Indicates the high-beam headlights have been set to automatic and are on. | |
|  | Grey | Automatic High-Beams Off | Indicates the high-beam headlights have been set to automatic and are off. | |
|  | Green | Automatic Low-Beams On | Indicates the low-beam headlights have been set to automatic and are on. | |
|  | Grey | Automatic Low-Beams Off | Indicates the low-beam headlights have been set to automatic and are off. | |
|  | Green | Daytime Running Lamps On | Indicates the daytime running lamps are on. | |
|  | Blue | Auxiliary Drive Lamps On | Indicates the auxiliary drive lamps are on. | |

Table 18, Lamp Indicators



| Telltale, Indicator Icons, and Messages — Lamps | | | | |
|---|-------|------------------------------|---|--|
|  | Blue | Utility Lamps On | Indicates the utility lamps are on. | |
|  | Green | Taillights / Marker Lamps On | Indicates the taillights, aka marker lamps, are on. | |

Table 18, Lamp Indicators



| Telltale, Indicator Icons, and Messages — Passenger Safety | | | | |
|---|-------|---|--|------------------|
| Telltale | Color | Description | | Related Messages |
|  | Red | Unfastened Seat Belt | <p>On some vehicles, activates with an audible alert when the system detects that the parking brake is off and the driver seat belt is not fastened.</p> <p>On vehicles with a seat occupancy sensor, the seat being occupied, seat belt not fastened, and parking brake off will cause this warning to activate.</p> <p>On other vehicles, this lamp illuminates for 15 seconds when the ignition is first turned on.</p> | |
|  | Amber | Supplemental Restraint System (SRS) Error | <p>Indicates a malfunction has occurred in the restraint system and restraint system components may be triggered unintentionally or may not deploy as intended during an accident.</p> <p>Have the restraint system checked and repaired immediately.</p> | |

Table 19, Passenger Safety Indicators

| Telltale, Indicator Icons, and Messages — Weather | | | | |
|---|-------|-------------|--|---|
| Telltale | Color | Description | | Related Messages |
|  | White | Snowflake | Indicates ambient air temperature has dropped below 34°F (1° C). Pay attention to road conditions and watch for ice. |  ICUC Caution |

Table 20, Weather-Related Indicators



| Telltale, Indicator Icons, and Messages — ICU Application | | | | |
|---|-------|-----------------------------|--|---|
| Telltale | Color | Description | | Related Messages |
|  | Blue | Active Phone Call | Indicates a phone is connected to the ICU and a call is active. | The phone screen in the infotainment section of the ICU will also show an active call, including the number being called and call length. |
|  | Blue | Software Download Available | Indicates a software download is available. For reasons of security and optimal vehicle functioning, software updates should be quickly installed. | A pop-up message will also appear. |

Table 21, ICU Application Icons

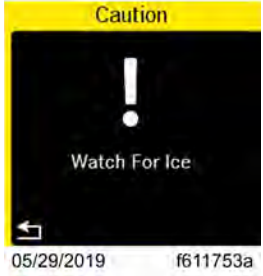

| Telltale, Indicator Icons, and Messages — Air Gauge | | | | |
|---|-------|-----------------------|--|------------------|
| Telltale | Color | Description | | Related Messages |
|  | Red | Primary Air Warning | | |
|  | Red | Secondary Air Warning | | |

Table 22, Air Gauge Indicators



| Telltale, Indicator Icons, and Messages — Air Gauge | | | | |
|---|-------|-------------------------|--|--|
|  | Red | Application Air Warning | | |
|  | Amber | Primary Air Caution | | |

Table 22, Air Gauge Indicators

4.10.04 Engine Protection System

**WARNING:**

When the red STOP engine lamp illuminates, most engines are programmed to shut down automatically within 30 seconds. The driver must immediately move the vehicle to a safe location at the side of the road to prevent causing a hazardous situation that could cause bodily injury, property damage, or severe damage to the engine.

See Chapter 14 Emissions and Fuel Efficiency for an explanation of the aftertreatment system (ATS) warning indicators, and actions required to avoid further engine protection steps.

The STOP engine lamp illuminates when the engine protection system is activated in one of two ways. On some engines, the engine protection system will derate the engine, allowing it to run at lower rpm and slower vehicle speed. Drive the vehicle to a safe location or to a service facility.

IMPORTANT: Safely bring the vehicle to a stop on the side of the road and shut down the engine as soon as the red light is seen. If the engine shuts down while the vehicle is in a hazardous location, turn the key to the OFF position for a few seconds, then restart the engine and move the vehicle to a safer location.

On other engines, the engine protection system will shut down the engine. It will first derate the engine, then shut it down completely 30 to 60 seconds after the indicator illuminates (depending on the critical fault type) if the condition does not improve. Bring the vehicle to a stop on the side of the road before the engine shuts down.

Some vehicles may have a shutdown-override switch, which may be used to momentarily override the shutdown sequence. See the chapter on **Engine Starting, Operation, and Shutdown** for detailed information regarding the shutdown process.

IMPORTANT: Do not attempt to restart the engine while the vehicle is moving. Bring the vehicle to a safe stop, then restart the engine.

To restart the engine, turn the ignition to OFF, leave it there a few seconds, then turn the ignition to START. The engine will run for a short period and shut down again if the condition does not improve.

| | |
|--|-----|
| 5.01 Ignition Switch..... | 161 |
| 5.02 Lighting Controls | 162 |
| 5.02.01 Exterior Lighting Controls | 162 |
| 5.02.02 Interior Lighting Controls | 168 |
| 5.03 Horn Controls | 171 |
| 5.03.01 Electric Horn..... | 171 |
| 5.03.02 Air Horn | 171 |
| 5.04 Powertrain Controls..... | 171 |
| 5.04.01 Aftertreatment System Regen Switches..... | 171 |
| 5.04.02 Axle Switches | 172 |
| 5.04.03 Engine Brake Switches..... | 173 |
| 5.04.04 Engine Fan Switch | 174 |
| 5.04.05 Hill Start Aid Override Switch | 174 |
| 5.04.06 Power Take-Off (PTO) Switch | 175 |
| 5.04.07 Transmission Controls..... | 175 |
| 5.05 Dash-Mounted Brake Controls | 176 |
| 5.05.01 Parking Brake Control Valve | 176 |
| 5.05.02 Trailer Air Supply Valve | 177 |
| 5.05.03 Trailer Brake Lever..... | 177 |
| 5.05.04 Antilock Braking System..... | 178 |
| 5.06 Windshield Wiper and Washer Controls | 179 |
| 5.06.01 General Description, Windshield Wiper and Washer Controls..... | 179 |
| 5.06.02 Wiper Controls..... | 179 |
| 5.06.03 Wipers and the Rain/Light Sensor | 180 |
| 5.06.04 Windshield Washers | 181 |
| 5.07 Suspension Controls | 181 |
| 5.07.01 Air Suspension Height Control Switch..... | 181 |
| 5.07.02 Aerodynamic Height Control | 182 |
| 5.07.03 ECAS Dash Switches..... | 183 |
| 5.07.04 ECAS Remote Control Unit..... | 185 |
| 5.08 Fifth Wheel Controls | 186 |

| | |
|--|-----|
| 5.08.01 Fifth Wheel Slide Control Switch | 186 |
| 5.08.02 Trailer Auxiliary Switch | 187 |
| 5.09 Adjustable Steering Column Controls..... | 187 |
| 5.10 Radio Controls | 188 |
| 5.11 Climate Controls..... | 189 |
| 5.11.01 Cab Climate Control | 189 |
| 5.11.02 Sleeper Climate Control..... | 190 |
| 5.12 Seat Controls | 191 |

5. Driver Controls

5.01 Ignition Switch

The ignition switch is located on the left-hand dash, below the headlight switch.

The ignition switch has four positions: OFF, ACC (accessory), ON, and START. See Fig.131, [Ignition Switch](#).

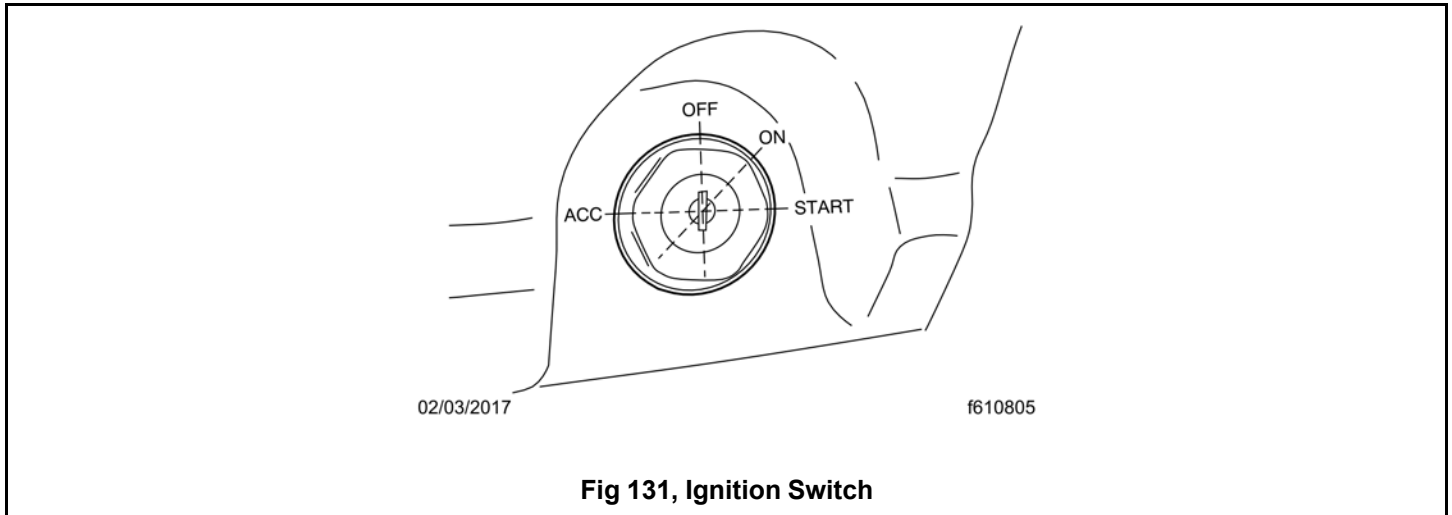

Fig 131, Ignition Switch

In the OFF position, the ignition switch is vertical. The key can be inserted and removed only in the OFF position.

The following functions are operable when the ignition switch is in the OFF position (regardless of whether the key is inserted):

- low-beam headlights
- taillights
- brake lights
- road lights
- dome lights
- clearance lights
- hazard warning lights
- utility lights
- baggage compartment lights
- spotlights
- electric horn
- clock
- refrigerator
- CB radio
- power mirrors
- power receptacle
- fuel heater
- electric oil pan heater

- electric or diesel-fired engine coolant pre-heater

Turn the key counterclockwise to reach the ACC position. In addition to all the functions that are operable in the OFF position, the following functions are operable when the switch is in the ACC position:

- radio/stereo system
- heater and A/C fan
- mirror defog
- windshield fan
- ether start system
- air dryer
- backup lights

Turn the key clockwise past the OFF position to reach the ON position. With the switch in the ON position, all electrical systems become operable and the warning and indicator lamps illuminate. Wait for three seconds before starting the engine.

IMPORTANT: Do not crank the engine until the ICU self-check is complete.

Turn the key clockwise past the ON position to reach the START position to start the engine. Release the key the moment the engine starts. Do not operate the starter longer than thirty seconds, then allow the starter to cool between attempts. If the starter overheats, the starter protection system will prevent operation of the starter until it has cooled.

The ignition key also locks and unlocks the cab doors.

5.02 Lighting Controls

5.02.01 Exterior Lighting Controls

Unless otherwise noted below, press the upper half of the switch to turn the desired light(s) on or off.

Exterior light controls are listed here in alphabetical order. The ICC5 also provides some exterior light controls.

Automatic Headlights

If the vehicle is equipped with a rain-light sensor and the headlight switch is in the 'A' position, the low beam headlights and all exterior lights activate when the outside light decreases to a pre-set level. See Fig.132, [Headlight Switch](#).



08/28/2018

f611525

- | | |
|--|------------------|
| 1. Fog Lights (optional)—Activate by pulling the switch out when the marker lights or headlights are on. | 3. Off |
| 2. Automatic Headlights | 4. Marker Lights |
| | 5. Headlights |

Fig 132, Headlight Switch**Auxiliary High Beam Lights**

If present, auxiliary high-beam lights are located in the front bumper. To activate the auxiliary high beam lights, press the upper part of the dash switch. The auxiliary high beam lights will illuminate only when the high-beam headlights are on. They will switch off temporarily when the low-beam headlights are on, until the high beams are on again. Press the upper half of the switch to deactivate the auxiliary high beam lights. See Fig. 133, [Dash-Mounted and Sleeper-Control Light Switches](#).

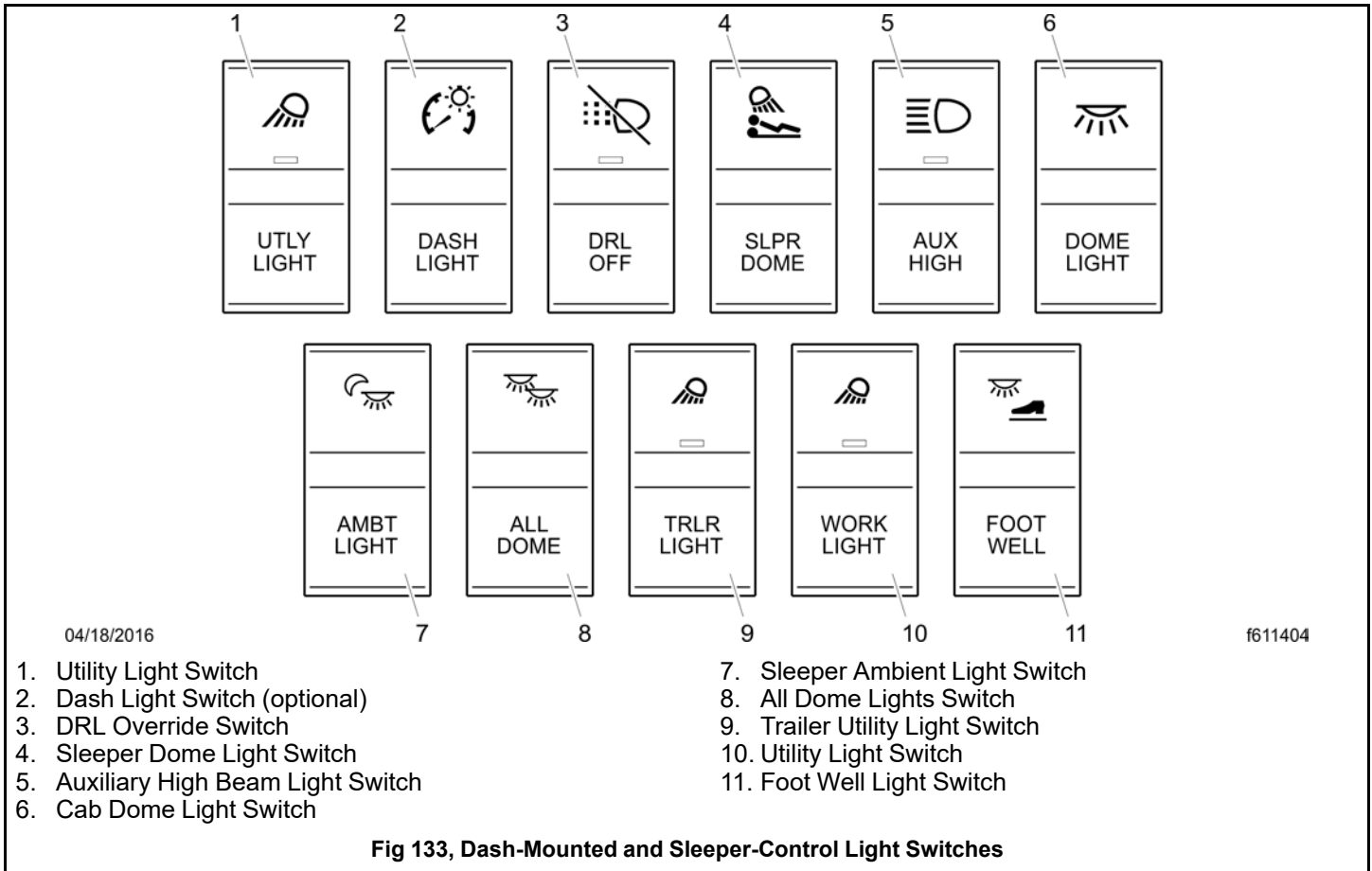

Backup Lights

Backup lights activate only when the vehicle is in reverse, and are designed to be used while backing up at night.

Daytime Running Lights

If the vehicle is equipped with daytime running lights (DRL), they are automatically activated when the ignition is switched on and the parking brake is released. The DRL turn off when the engine falls below 400 rpm, the parking brake is applied, or the headlights are turned on.

Daytime running lights are mandatory for vehicles domiciled in Canada. Vehicles domiciled in any other location may have an optional override switch (see Fig.133, [Dash-Mounted and Sleeper-Control Light Switches](#), ref. 3). This is a momentary switch that enables the driver to deactivate the DRL.

NOTE: For right-hand drive vehicles domiciled in Australia, the rear lights do not come on while daytime running lights are on.

Fog Lights

Fog lights are designed to reduce glare in foggy conditions. The marker lights or headlights must be on in order to turn the fog lights on. Pull the headlight switch outward to activate the fog lights.

Hazard Warning Lights

The hazard warning light switch is located on the dash switch panel. See Fig.134, [Hazard Warning Switch](#). The hazard lights can be activated regardless of the ignition switch position.

To activate the hazard lights, press the center of the switch once. The switch will blink at the same rate that the hazard lights flash. Press the switch again to turn them off. All the turn signals on the vehicle and trailer, as well as the turn signal indicators in the ICU, flash simultaneously when the hazard lights are activated.



Fig 134, Hazard Warning Switch

Headlights & Follow Me Home Feature

The headlight switch is a rotary switch located to the left of the steering column, above the ignition switch. See Fig. 132, [Headlight Switch](#).

If the Follow Me Home feature is activated, the low-beam headlights will remain on for nine seconds after the vehicle is parked, if the headlights were on prior to engine shutdown. This feature provides temporary lighting in the path of the headlights while walking to a building or other destination. If a vehicle door is opened or closed while this feature is active, the timer will add an additional 10 seconds of lighting. This feature can be temporarily disabled by turning the ignition switch on, or by cycling the headlight switch from the off position to one of the other two positions.

Some vehicles may have a feature that automatically turns on the headlights if the windshield wipers are on and the vehicle is moving faster than 10 mph (16 km/h). At speeds between 10 and 40 mph (16 to 64 km/h), cycling the headlight switch will turn the headlights off.

High-Beam Headlights

With the low-beam headlights on, push the turn-signal lever away from you to turn on the high-beam headlights. See Fig. 135, [Steering Column-Mounted Turn Signal Lever](#). To turn off the high-beam headlights, pull the lever to the middle position.

With the low-beam headlights on, pull the lever towards you to flash the high-beam headlights momentarily.

When the high-beam headlights are on, a blue telltale illuminates on the instrument cluster.

NOTE: The ignition switch must be on for the high beams to work.

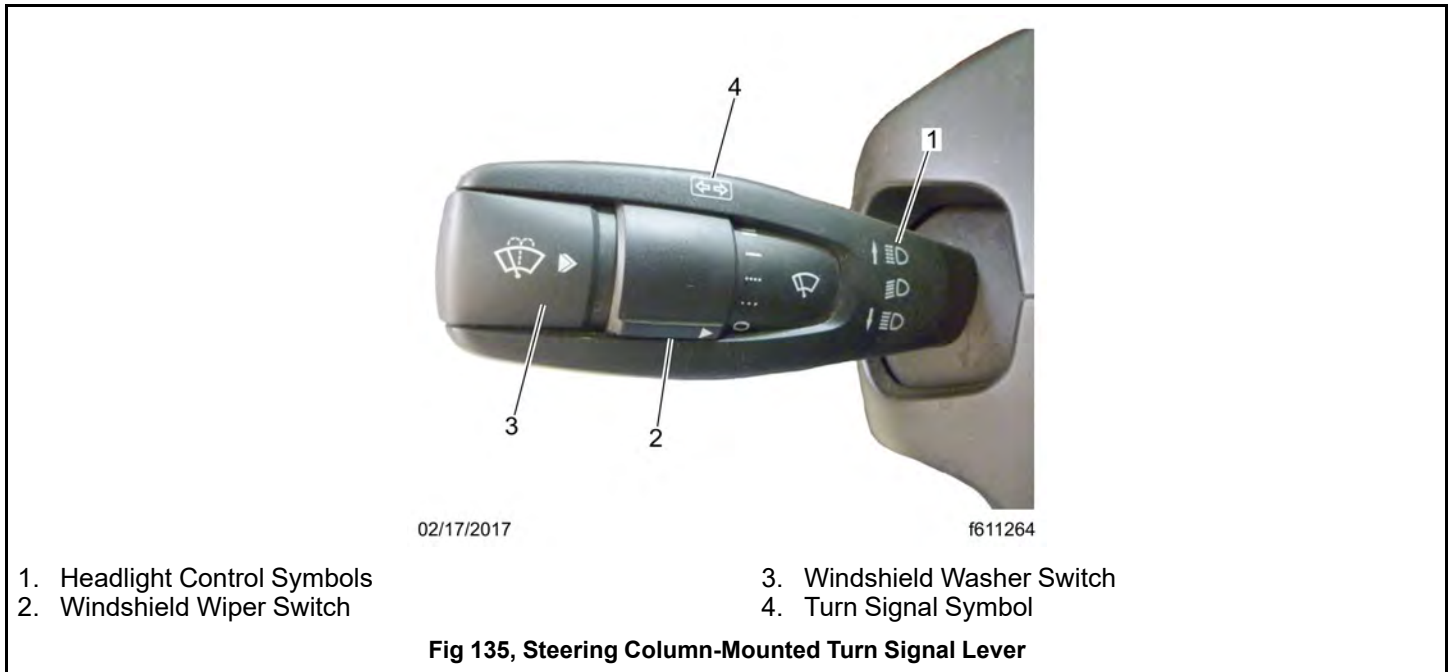

Intelligent High-Beam Headlights

The intelligent high-beam headlight feature activates when the headlight switch is in the 'A' position and the turn signal lever is pushed away from the driver in the high-beam position. See Fig. 132, [Headlight Switch](#) and Fig. 135, [Steering Column-Mounted Turn Signal Lever](#).

When a vehicle approaches from the opposite direction, the high-beam headlights deactivate and the low-beam headlights activate. The high-beam headlights activate again when there are no vehicles approaching from the opposite direction.

Marker Lights

To turn the marker lights on, turn the headlight switch clockwise past the off position. See Fig. 132, [Headlight Switch](#).

Marker Interrupt

NOTE: This switch may not be available in all export markets.

The marker interrupt switch is located in the right-hand switch pod of the steering wheel for the ICUC system (see Fig. 136, [Steering-Wheel-Mounted Right-Hand Switch Pod - ICUC](#)), and the left-hand button pod of the steering wheel for the ICC5 button (see Fig. 137, [Steering-Wheel-Mounted Left-Hand Pod - ICC5](#)). Pressing it temporarily flashes the marker lights.

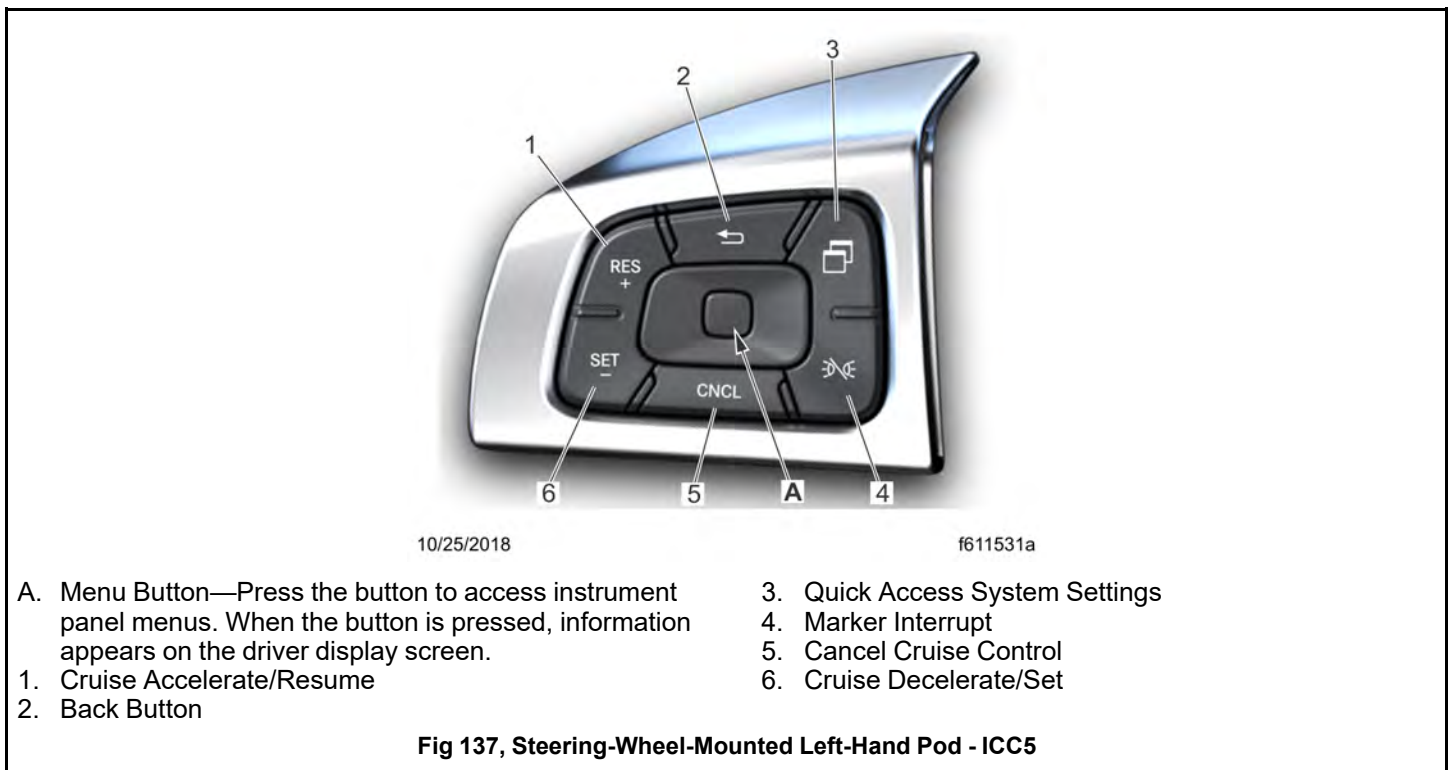

Pretrip Light Test Switch

When the driver presses the pretrip light test switch, shown in Fig. 138, [Pretrip Light Test Switch](#), all exterior lights are activated so the driver can exit the vehicle and verify they are working properly. For additional information see [26.01 Safety Precautions](#) Pre- and Post-Trip Inspections and Maintenance.

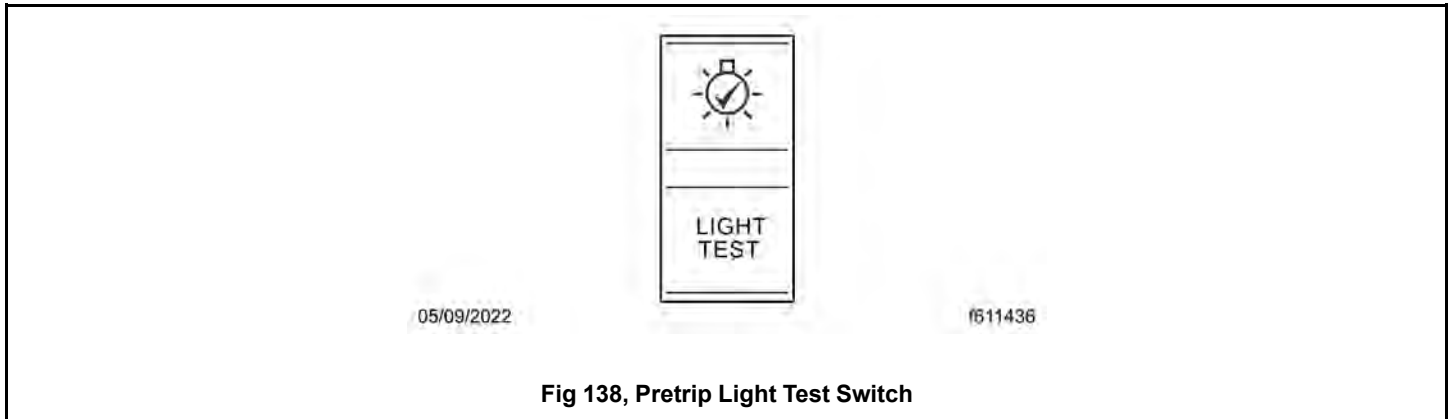

Spotlight

The spotlight switch is located on the pivoting handle of the spotlight. There may be a single spotlight assembly mounted above the driver's door, or one above each door.

Turn Signals

The turn-signal lever is mounted on the left-hand side of the steering column. Pulling the turn-signal lever up activates the right-turn signal; pushing it down activates the left-turn signal. The lever is typically a non-canceling combination turn-signal, windshield wiper/washer switch, and high beam headlight control unit. See Fig. 135, [Steering Column-Mounted Turn Signal Lever](#).

When a turn signal is activated, a green telltale light flashes on the instrument panel.

On a self-canceling turn signal lever, the lever automatically returns to the neutral position when the steering wheel returns to the straight-ahead position after a turn.

Utility Lights

Utility lights can be swivel-mounted on upper half of the cab, mounted on the exhaust support, or flush-mounted on the back of the cab or sleeper. Press the upper half of the switch to turn the utility lights on or off.

When activated, a red indicator light in the switch is illuminated.

5.02.02 Interior Lighting Controls

Unless otherwise noted below, press the upper half of the switch to turn the desired light(s) on or off.

Interior light controls are listed here in alphabetical order.

The interior lights include panel lights, dome lights, reading lights, and courtesy lights.

Vehicles come pre-set from the factory with theater lighting, which ramps up lights from low power to full power when activated. See Fig. 139, [Cab and Sleeper Interior Lighting](#).

Sleepers have rear dome lights, ambient lights, reading lights, task lights, foot well lights, and baggage compartment lights.

Many interior lights have a dimming function. By holding down the switch, the lights can be cycled between bright and dim.

The ICC5 provides some digital interior light controls. See [4.01.01 General Description Instruments](#) for more information.

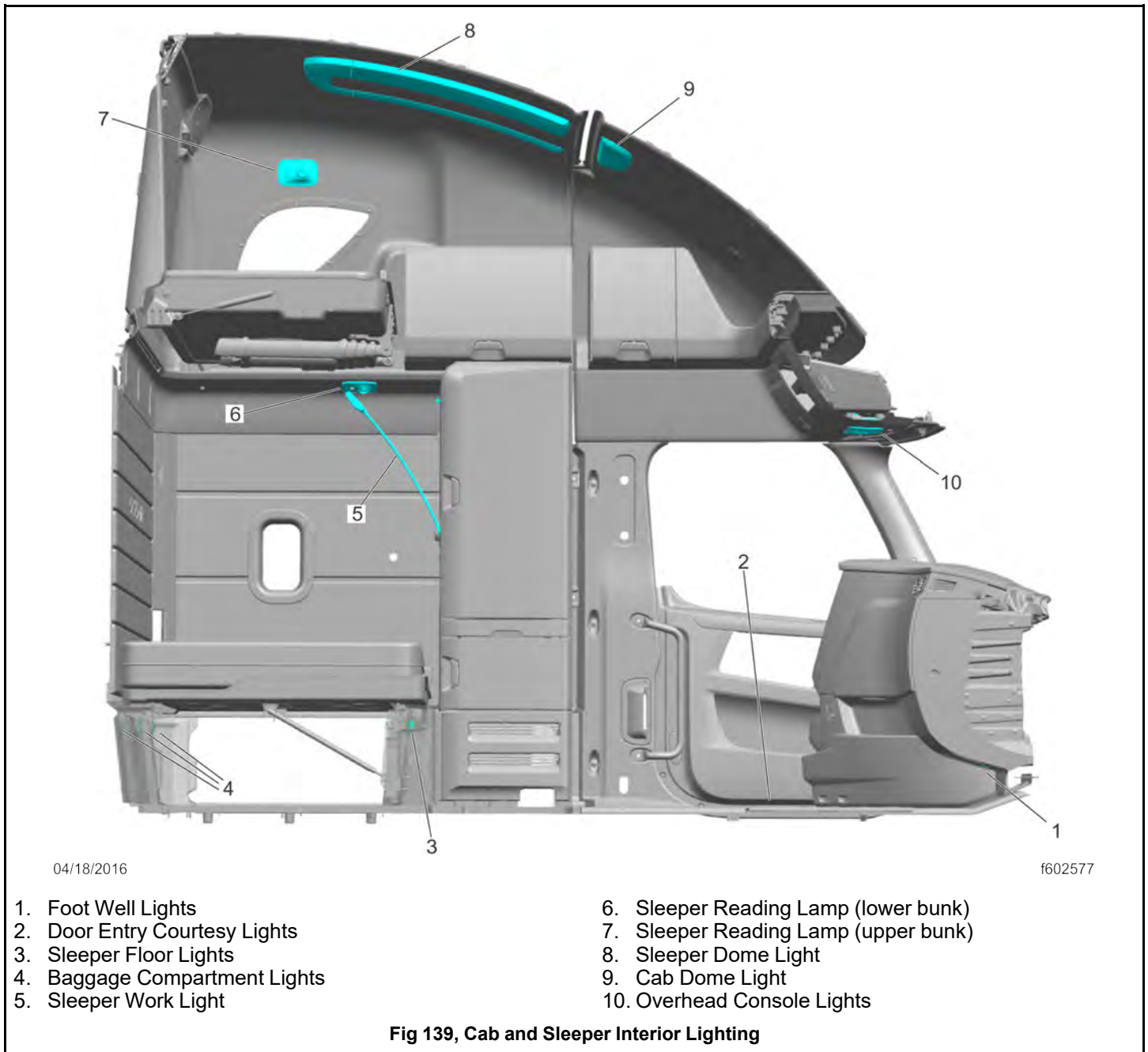

Baggage Compartment Lights

Baggage compartment lights are located on the underside of the lower bunk, on both sides. Both lights turn on when either baggage compartment door is opened to illuminate the baggage compartment. The lights also come on when the lower bunk is raised.

Foot Well Lights

When the driver or passenger doors are opened, amber lights illuminate both foot wells. These lights can also be activated with the foot well light switch. See Fig.140, [Dash-Mounted and Sleeper-Control Light Switches](#). Press the upper half of the switch to turn the foot well lights on or off.

Overhead Console Lights

The overhead console lights consist of two dome lights, two reading lights, and an amber lamp that provides ambient light for the center dash panel and the cup holders. The dome lights illuminate when a door opens, then stay on for a short time after both doors are closed. Press the lens of the reading light or dome light to activate each one independently of the others.

Dash Lights

The dash lighting illuminates independently of the headlights. The brightness can be set to adjust automatically based on ambient lighting.

The brightness can also be adjusted in either the ICUC or ICC5 under the Settings menu or through the use of an optional dash switch.

When using the dash switch, the panel lights brighten and dim in 10% increments, depending on whether the upper half or the lower half of the switch is pressed. When the panel lights are turned on with the switch, they will default to the intensity that was last set.

Cab Dome Light

A rear cab dome light is located on the headliner, between the bunk and the cab on sleeper vehicles. The rear cab dome light will activate with the dome lights when a door is opened, then stay on for a short time after both doors are closed. The length of time this courtesy lighting stays on can be controlled via the settings menu in any ICU system as can the time the entrance light stays on.

Use the dash-mounted switch or the switch in the sleeper panel to activate the rear cab dome light. See Fig. 140, [Dash-Mounted and Sleeper-Control Light Switches](#).

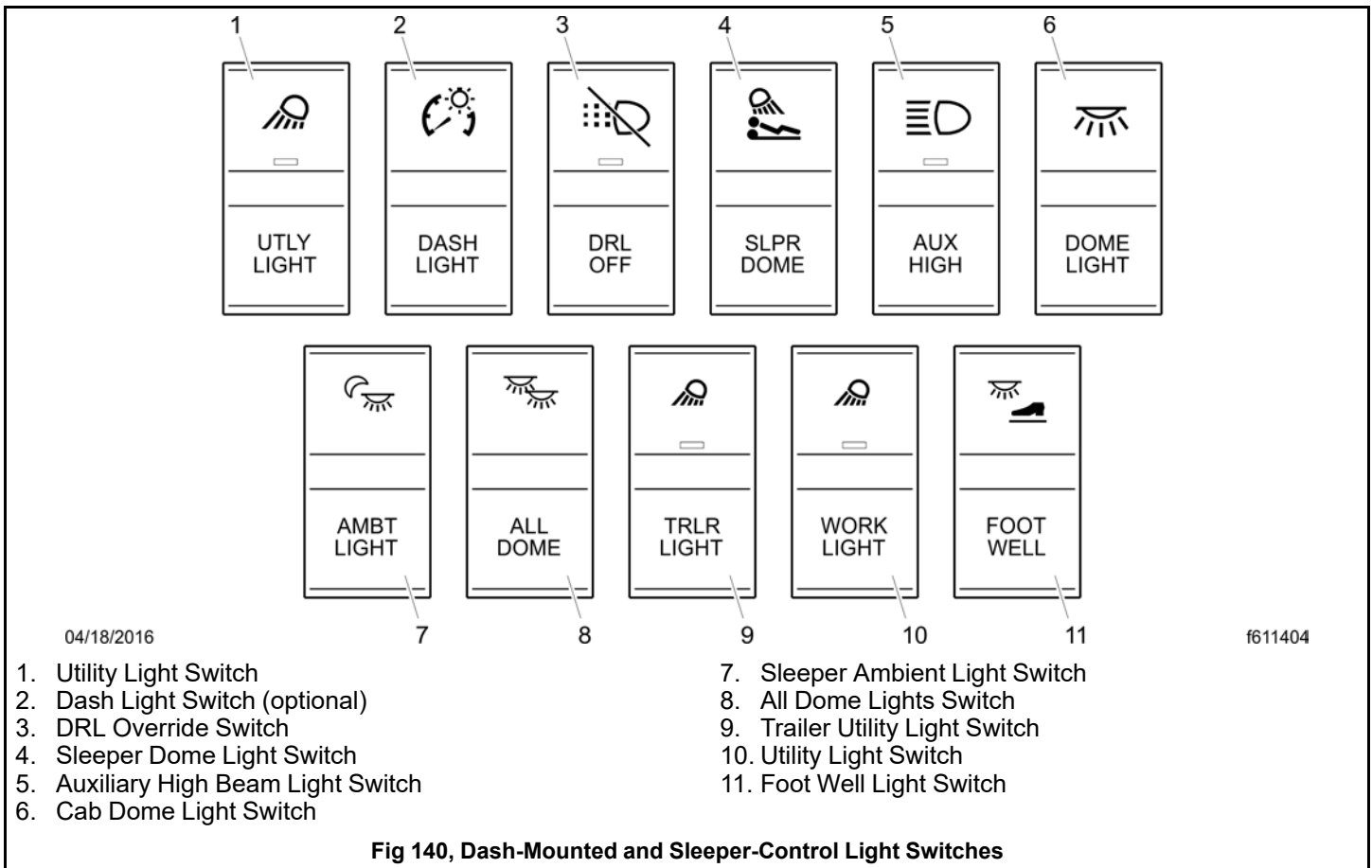

Sleeper Dome Light

The sleeper dome light has both direct and ambient lights, controlled by separate switches.

Sleeper Foot Well Lights

The sleeper foot well switch activates two lights that illuminate the sleeper floor.

Sleeper Reading Lights

Reading lights are mounted above bunks in the sleeper. To turn a reading light on or off, press the switch on the lamp.

Theater Lighting

Some vehicles come pre-set with theater lighting. Theater lighting gradually illuminates the overhead and reading lights when they are turned on and a gradually dims these lights when they are turned off.

5.03 Horn Controls

5.03.01 Electric Horn

An electric horn is standard equipment.

Activate the electric horn by pressing down on the steering wheel center pad.

The horn will sound for the duration of the pad being pressed, up to 60 seconds. The electric horn will operate regardless of the position of the ignition key.

5.03.02 Air Horn

If equipped, air horn(s) may be mounted on the roof of day cabs, or under the driver-side floor for sleeper cabs. The air horn is controlled by a wire lanyard that hangs down inboard by the driver's door. See Fig.141, [Air Horn Control](#). Pull downward on the lanyard to activate the air horn.

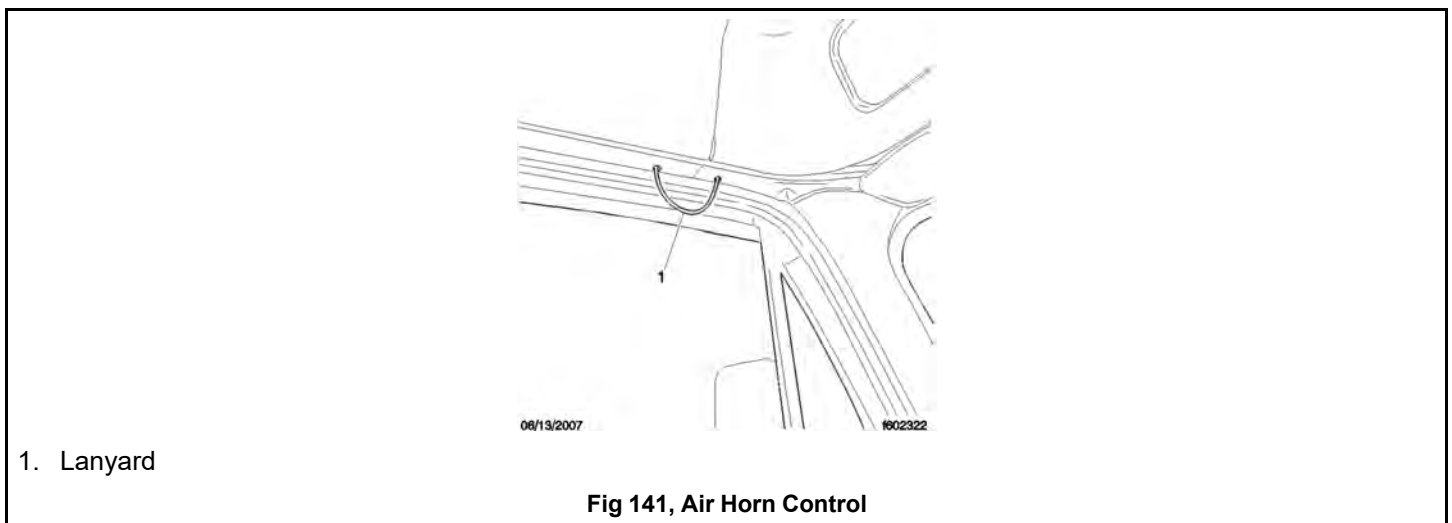

5.04 Powertrain Controls

5.04.01 Aftertreatment System Regen Switches

NOTE: See **Chapter 14** Emissions and Fuel Efficiency for detailed information about the operation of the regeneration (regen) switches and the aftertreatment system (ATS).

Regen may be started manually with the optional digital switch in the ICU. See Fig.142, [Regen Start Digital Switch - ICU](#).

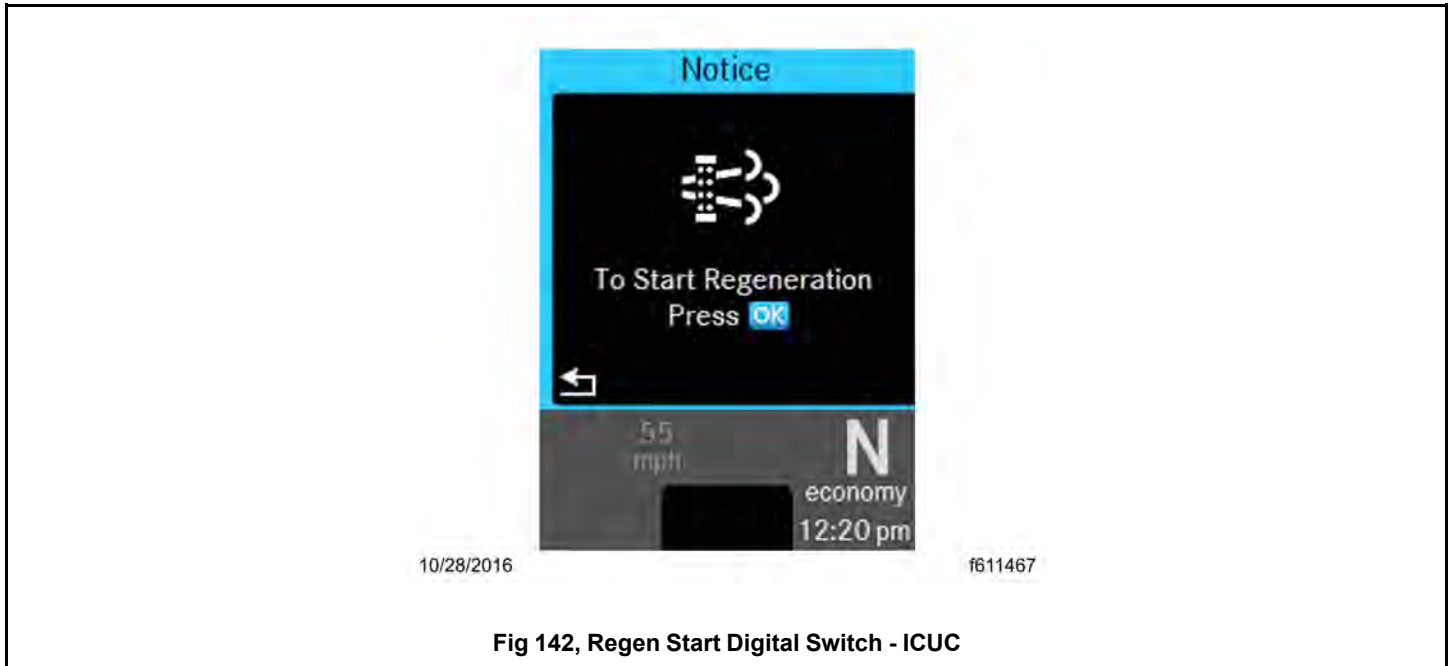

Fig 142, Regen Start Digital Switch - ICUC

Some vehicles may be equipped with a regen inhibit switch. See Fig.143, [Regen Inhibit Switch](#). To stop a regen in progress or prevent the start of a regen, press the upper half of the switch. Regen will be delayed until the switch is no longer active.

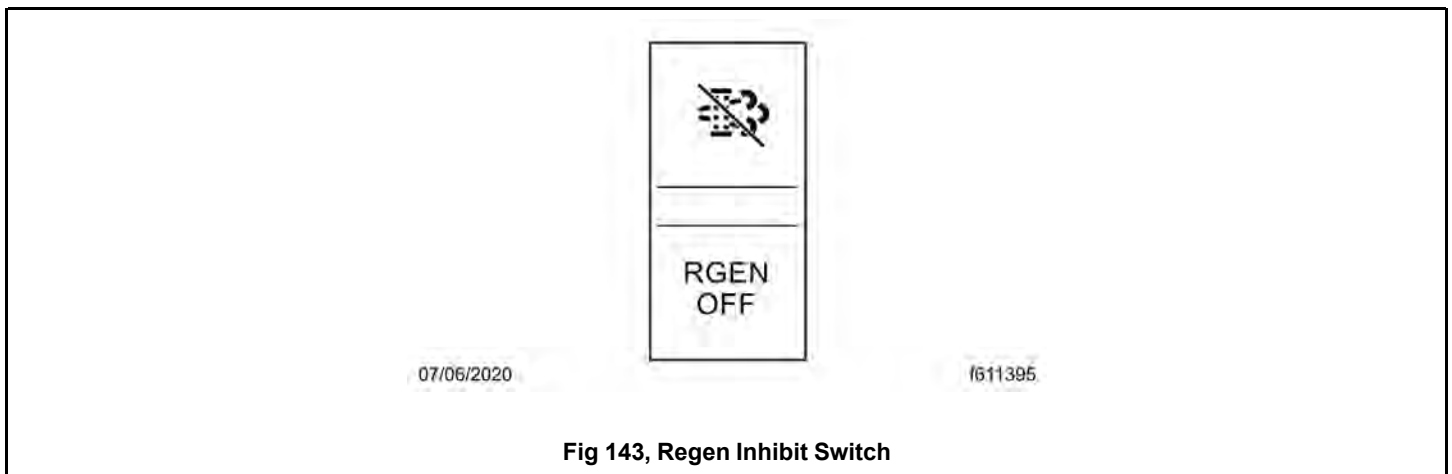
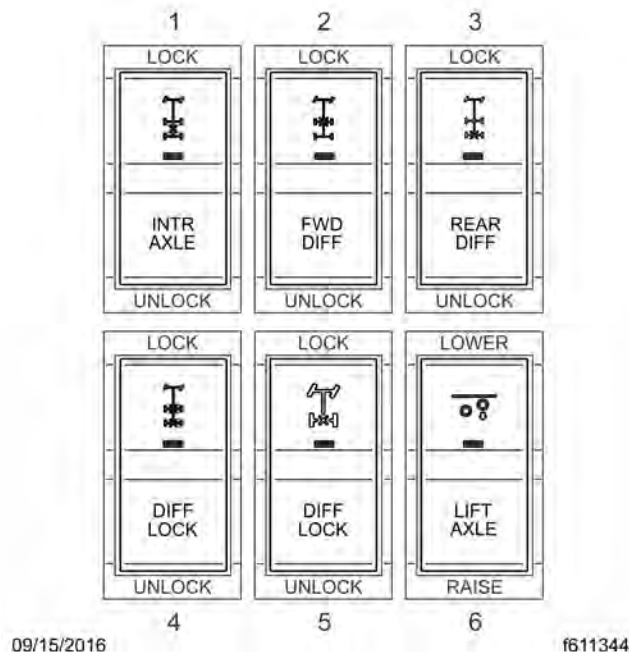

Fig 143, Regen Inhibit Switch

5.04.02 Axle Switches

Some vehicles are equipped with an interaxle differential lock switch and/or a switch for each driver-controlled differential lock (DCDL). See Fig.144, [Axle Switches](#).

For more information about differential locks and using them for traction control, see [20.01.01 General Description, Interaxle Lock and Tandem Axles Drive Axles](#).



- | | |
|--|----------------------------------|
| 1. Interaxle Lock Switch | 4. Differential Lock Switch, 6X4 |
| 2. Forward Drive Axle Differential Lock Switch | 5. Differential Lock Switch, 4X2 |
| 3. Rear Drive Axle Differential Lock Switch | 6. Lift Axle Switch |

Fig 144, Axle Switches

5.04.03 Engine Brake Switches

NOTE: See [16.01.01 Brake System General Information](#) Brake Systems for detailed information about engine brake operation.

Whenever vehicle braking is required on good road conditions, the engine brake may be used in conjunction with the service brakes. There is no time limit for operation of the engine brake. However, an engine brake does not provide the precise control of, and is not a substitute for, service brakes.

The engine brake control is located on the right-hand steering-column-mounted lever. At the top position, the engine brake is off, and at the three lower positions, the brake is on and the intensity (low, medium, high) increases with each step down. See Fig.145, [Engine Brake Positions](#).

NOTE: Cruise control and safety systems may activate the engine brake regardless of the lever position.

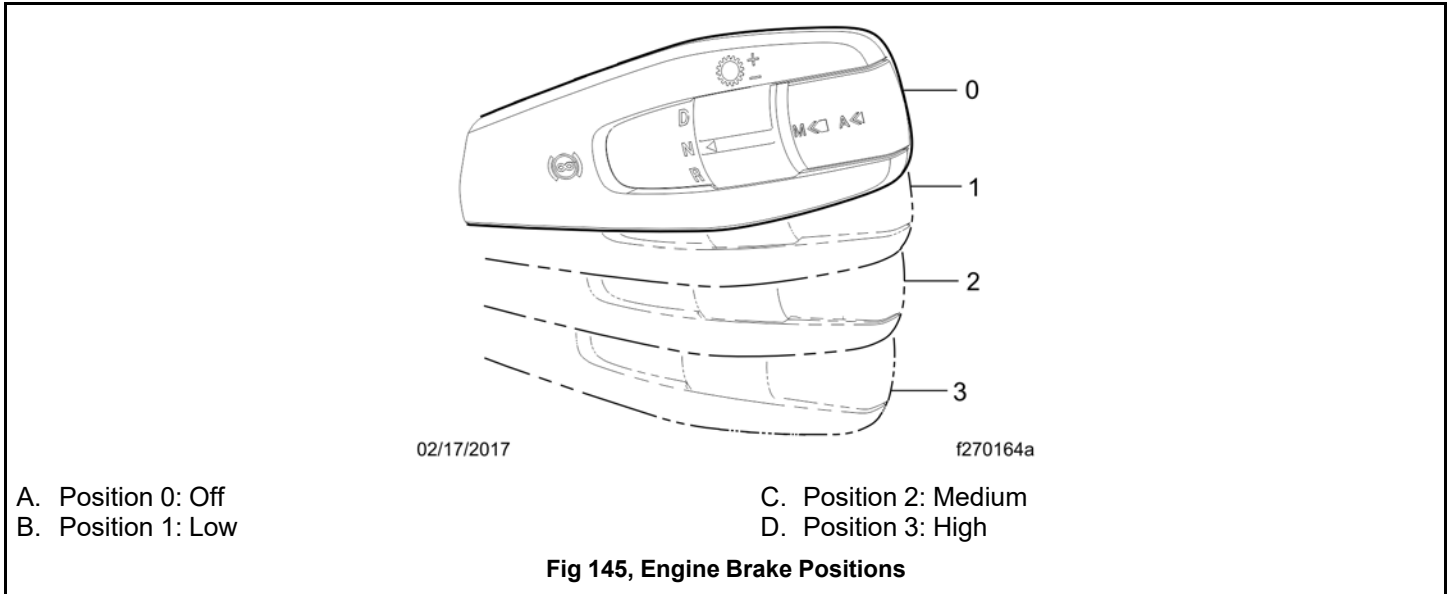

5.04.04 Engine Fan Switch

The engine cooling fan can be turned on by the engine fan switch.

To turn the engine fan on, press the upper half of the switch. The fan will continue to operate for a set amount of time and then turn off unless the coolant temperature is high enough to continue fan operation. To turn the fan off before the set time period ends, press the lower half of the switch. See Fig. 146, [Engine Fan Switch](#).

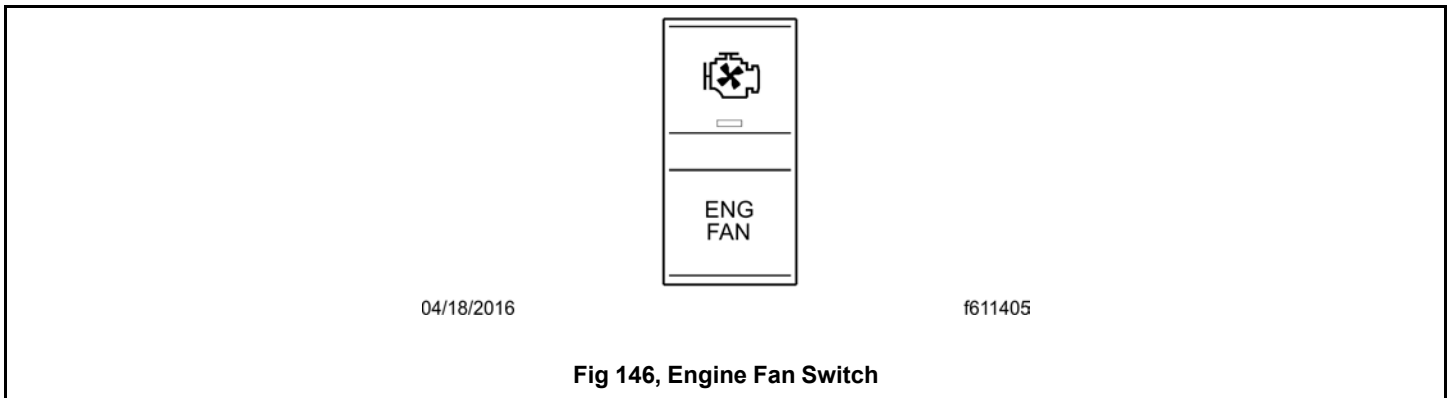

5.04.05 Hill Start Aid Override Switch

Some vehicles are equipped with a Hill Start Aid (HSA) feature to prevent the vehicle from rolling while on steep grades and to allow for a controlled launch. HSA delays the release of the service brakes until enough torque is available to begin moving the vehicle forward, for a maximum of 3 seconds. HSA is "on" by default. It can be turned off by pressing and releasing the HSA override switch on the dash (see Fig. 147, [Hill Start Aid Override Switch](#)).



Fig 147, Hill Start Aid Override Switch

5.04.06 Power Take-Off (PTO) Switch

To activate the PTO function, press the upper half of the switch. Press the lower half of the switch to deactivate the PTO function. See Fig. 148, [PTO Switch](#).

Power Take-Off may also be activated using the digital switch in the ICU.



WARNING:

To avoid injury, do not install a PTO that is not Detroit Diesel approved onto a Detroit Transmission. Use of a non-Detroit Diesel approved PTO with a Detroit Transmission could result in unintended operation which could lead to severe personal injury.

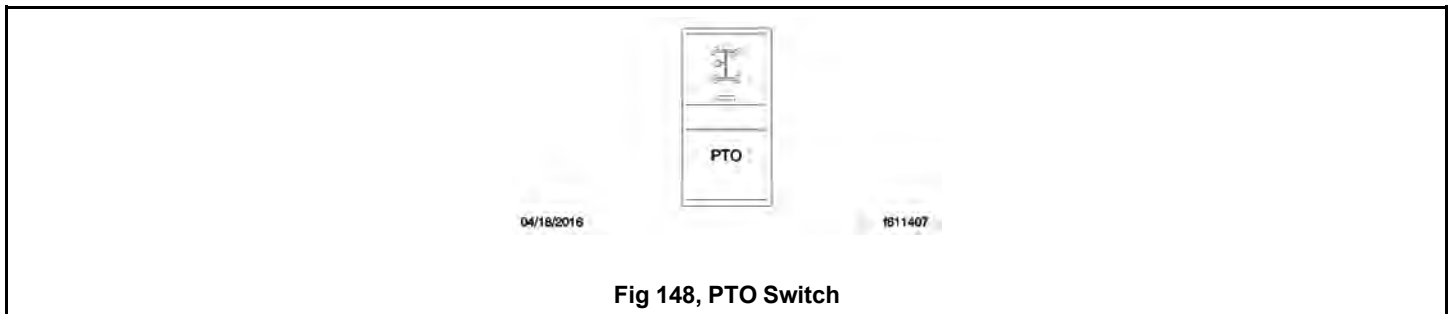

Fig 148, PTO Switch

5.04.07 Transmission Controls

Detroit Automated Transmissions

NOTE: See the chapter on **Automated and Automatic Transmissions** for automated transmission operating instructions.

Vehicles with automated and automatic transmissions use the multifunction control shown in Fig.

149, [Automated/Automatic Transmission Multifunction Control](#). This control moves in two directions and has two switches. It is used to request manual shifts, change shift mode, set engine brake levels, and control specialty engine brake functions.

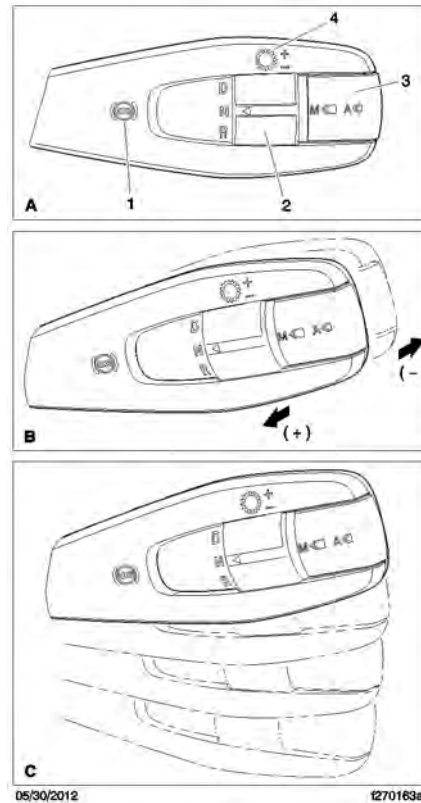

- A. Front View
- B. Shift Up/Down Requests
- C. Four positions for engine brake settings
- 1. Engine Brake Symbol
- 2. Drive/Neutral/Reverse Switch
- 3. Shift Mode Switch (Economy/Performance/Manual)
- 4. Gear Shift Symbol

Fig 149, Automated/Automatic Transmission Multifunction Control

Manual Transmissions

NOTE: See the chapter on **Manual Transmissions and Clutch** for manual transmission operating instructions.

If so equipped, the transmission range control and splitter valves are attached to the gear shift knob.

The range-preselection lever allows the selection of the low or high range for each transmission ratio. It is used once during an upshift sequence and once during a downshift sequence.

Dependent on the transmission model, some ratios can be split using the splitter-control button.

5.05 Dash-Mounted Brake Controls

5.05.01 Parking Brake Control Valve

NOTE: See **Chapter 15** Brake Systems for detailed information about brake systems.

The yellow diamond-shaped knob operates the parking brake valve. See Fig.150, [Brake Valve Control Knobs](#). Pull the knob out to apply both the tractor and the trailer spring parking brakes. Push both the parking brake and the trailer air supply knobs in to release the tractor and trailer spring parking brakes. Before the spring parking brakes can be released, the air pressure in either air brake system must be at least 65 psi (447 kPa).

If the trailer is not equipped with spring parking brakes, pull the parking brake valve out to apply the tractor parking brakes and the trailer service brakes.

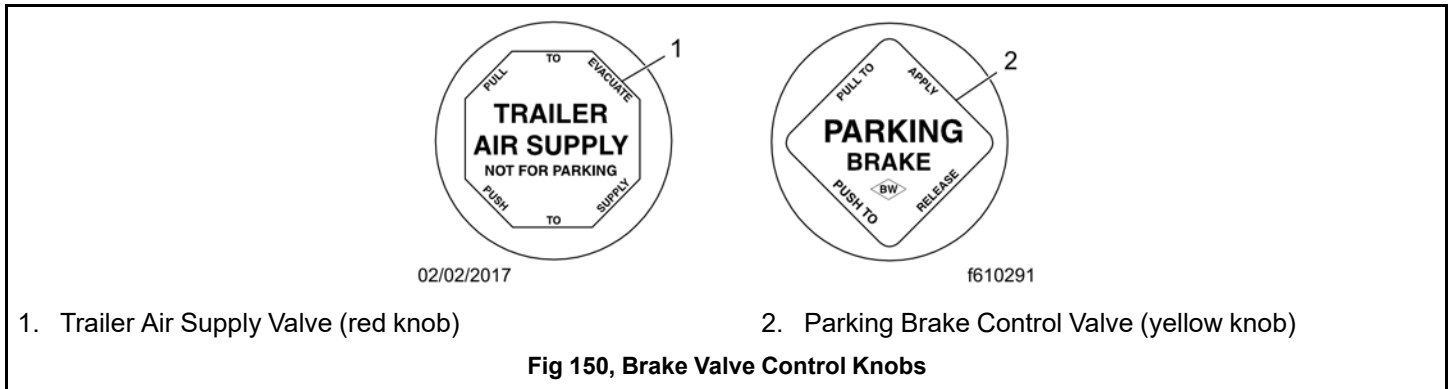

5.05.02 Trailer Air Supply Valve

The red octagonal-shaped knob operates the trailer air supply valve, which charges the trailer air supply system and releases the trailer spring parking brakes. See Fig.151, [Brake Valve Control Knobs](#).

After the vehicle and its air hoses are connected to a trailer and the pressure in the air system is at least 65 psi (447 kPa), push the trailer air supply valve knob in (and leave it in) to charge the trailer air supply system and release the trailer spring parking brakes. Pull the trailer air supply valve out before disconnecting a trailer or when operating a vehicle without a trailer.

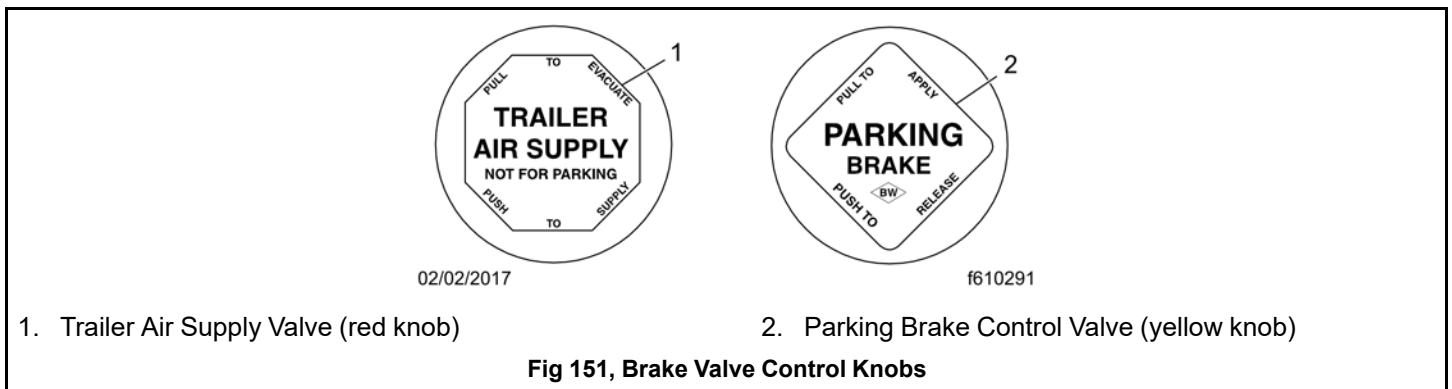

5.05.03 Trailer Brake Lever

The trailer brake lever is used to apply the trailer service brakes without applying the truck or tractor service brakes. It is usually mounted on the right-hand control panel. Move the lever down to apply the trailer brakes; move the lever up to release the trailer brakes. The lever will automatically return to the up position when it is released. See Fig.152, [Trailer Brake Lever](#). The lever can be partially or fully applied, but in any partially on position it will be overridden by a full application of the service brake pedal.

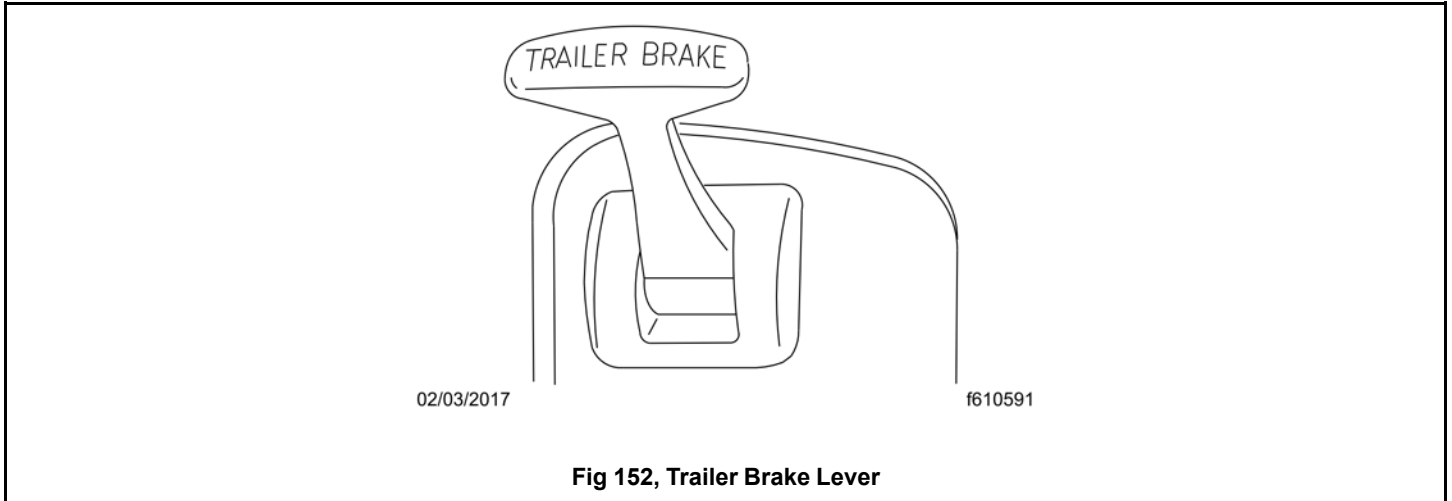

5.05.04 Antilock Braking System

The Meritor WABCO® Antilock Braking System (ABS) passively monitors vehicle wheel speed at all times, and controls wheel speed during emergency stops or wheel lock situations.

During emergency or reduced-traction stops, fully depress the brake pedal until the vehicle comes to a safe stop. **Do not pump the brake pedal.** With the brake pedal fully depressed, the ABS will control all wheels to provide steering control and a reduced braking distance.

The ABS is designed to communicate with a trailer ABS, if they are compatible. Compatibility will result in the illumination of the trailer ABS lamp during vehicle start-up and fault detection. The trailer ABS lamp will not illuminate unless a compatible trailer is connected to the tractor.

Vehicles with ABS may have Automatic Traction Control (ATC). On these vehicles, the ATC system automatically limits wheel spin during reduced-traction situations. In normal braking applications, the standard air brake system is in effect.

Pressing the ATC SPIN switch (see Fig. 153, [ATC SPIN Switch](#)) shuts ATC off and allows drive wheel spin. Pressing the switch again, or cycling the ignition key, will cycle the system back to normal operation.



NOTICE:

The ATC spin feature is intended to be used under specific slippery conditions that require momentary increased wheel spin. Using this option for an extended period of time may damage the vehicle brake system.

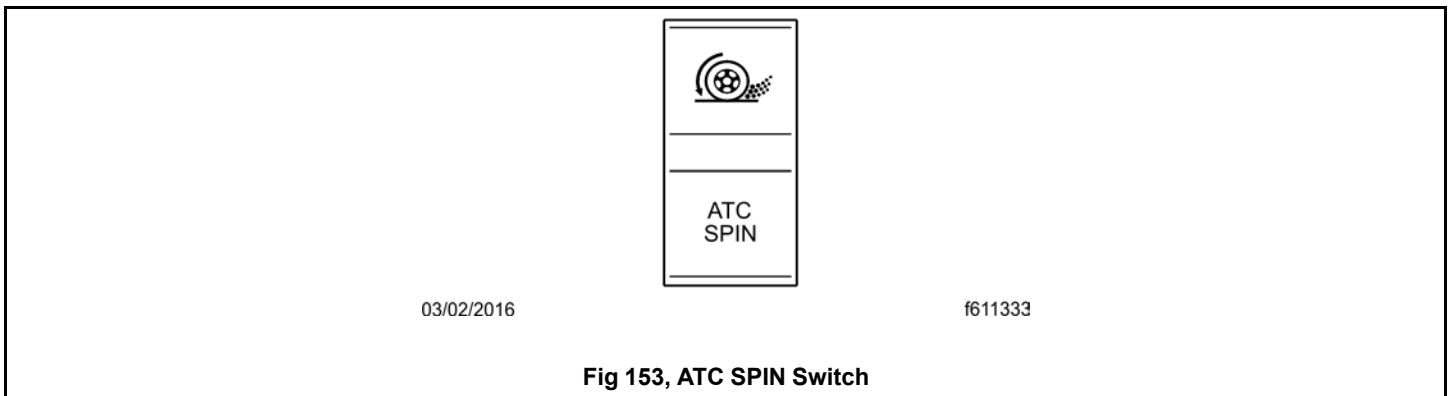

5.06 Windshield Wiper and Washer Controls

5.06.01 General Description, Windshield Wiper and Washer Controls



NOTICE:

Do not attempt to manually move the windshield wiper arms. Wiper motor damage will occur if the arms are forcibly moved.

The windshield wipers and washer controls are on the multi-function turn signal lever on the left-hand side of the steering column. See Fig. 154, [Windshield Wiper/Washer Controls](#).

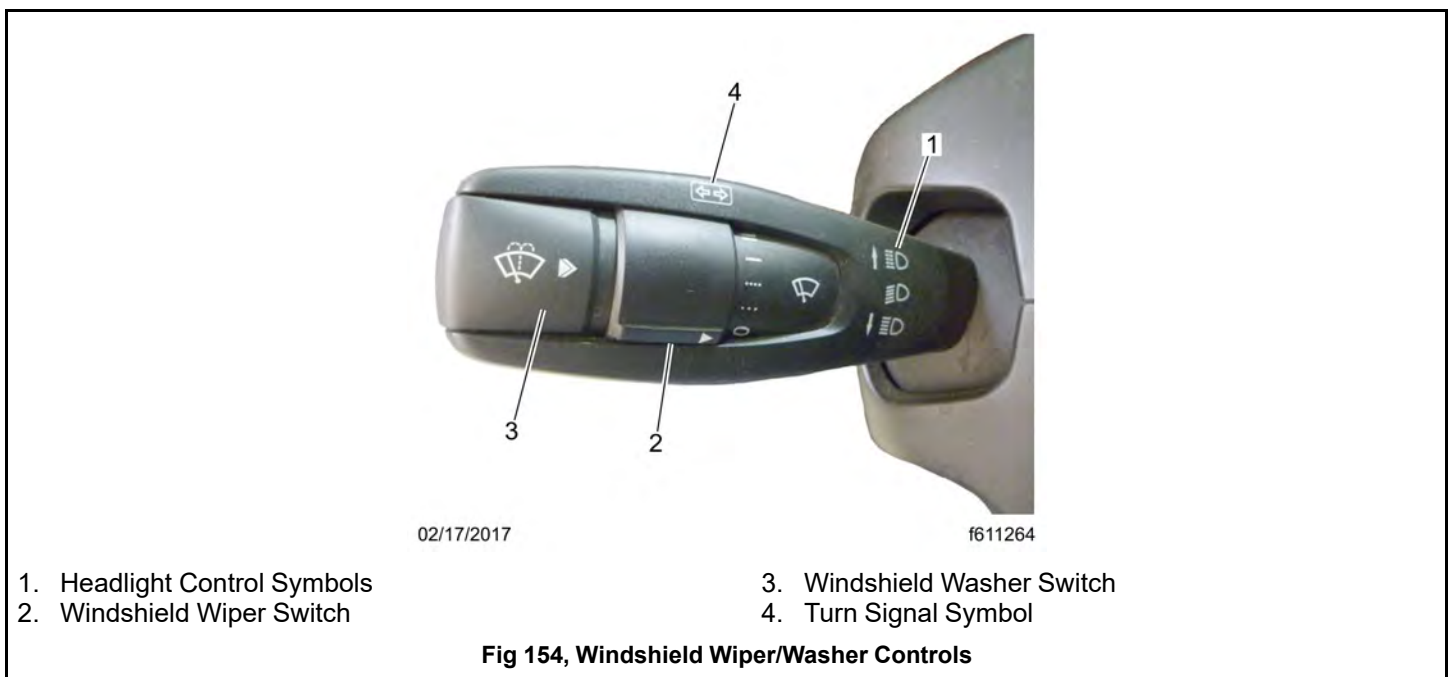

5.06.02 Wiper Controls

The wipers are operated by a rotary switch on the turn signal lever. There are five settings: off, two intermittent settings, and two continuous speeds. Symbols mark each setting on the dial.

Turn the wipers on by rotating the rotary switch up. Rotate the switch further to increase the speed of the wipers through the two intermittent settings, then to continuous low and high speeds. Rotate the switch down to slow the wipers down. Rotate the switch as far down as it will go to turn the wipers off.

The default speeds for the two intermittent settings are 6 seconds and 1 second.

The first intermittent setting of 6 seconds is programmable from 1 to 25 seconds. To program the interval, rotate the switch from the first intermittent position to the OFF position, wait for the desired interval between wipes to lapse (between 1 and 25 seconds), and then move the switch back to the first intermittent position. If the switch is kept in the OFF position for more than 50 seconds, the interval changes back to the default of 6 seconds.

The second intermittent setting has an interval of 1 second, and is not programmable.

NOTE: Some vehicles may have a feature that automatically turns on the headlights if the windshield wipers are on and the vehicle is moving faster than 10 mph (16 km/h). At speeds between 10 and 40 mph (16 to 64 km/h), cycling the headlight switch will turn the headlights off.

5.06.03 Wipers and the Rain/Light Sensor

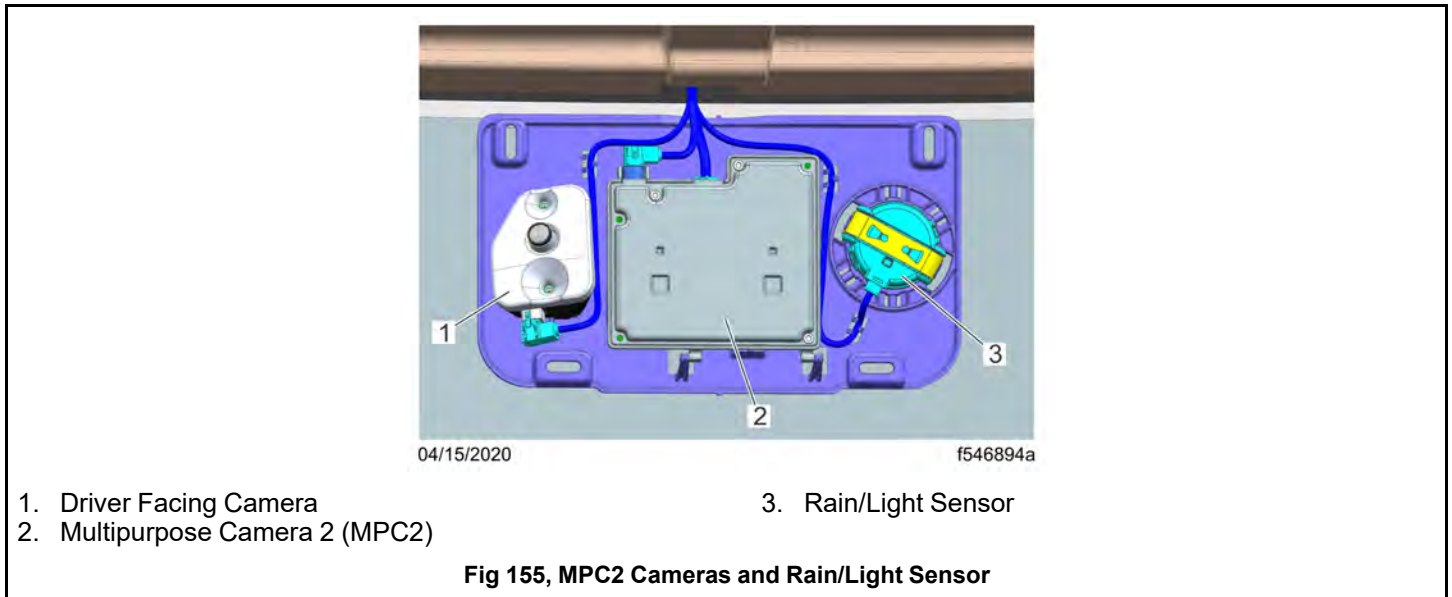

If the vehicle is equipped with a rain/light sensor (see Fig.155,[MPC2 Cameras and Rain/Light Sensor](#)) and the wiper switch is in set to an intermittent setting, the wipers will start when the sensor detects rain or snow.

If the vehicle is moving faster than 40 mph (64 km/h) the wiper speed will automatically increase and decrease, dependent upon how much moisture builds up on the windshield between wipes.

If the wiper switch is set to a continuous speed (low or high), input from the rain/light sensor is ignored.

The behavior of the wipers based on the rain/light sensor input is independent of the headlamp switch position.

NOTE: If a rain/light sensor is installed in the MPC2 bracket, the lens area of the camera will appear shiny when viewed through the windshield because of the silicone gel between the lens and the windshield. If no rain/light sensor is installed, the plastic plug placed in the bracket will appear as a flat black circle. A vehicle equipped with automatic headlights and an A option on the headlight switch (see Fig.156,[Headlight Switch](#)) should be equipped with a rain/light sensor.



08/28/2018

f611525

- | | |
|--|------------------|
| 1. Fog Lights (optional) Activate by pulling the switch out when the marker lights or headlights are on. | 3. Off |
| 2. Automatic Headlights | 4. Marker Lights |
| | 5. Headlights |

Fig 156, Headlight Switch

5.06.04 Windshield Washers

The windshield washer button is located at the end of the turn signal lever. Momentarily press the windshield washer button to initiate a single wipe without activating the washer pump. The wipers will swipe one full cycle and return to the inactive position.

To operate the windshield washers, press and hold the button in. After a short delay, the washer will pump windshield washer fluid onto the windshield for as long as the washer button is pressed. The windshield wipers will turn on at low speed while the washer button is pressed. After the button is released, the wipers will continue to operate for one to several wipe cycles, depending on how long the wash button was pressed initially.

5.07 Suspension Controls

5.07.01 Air Suspension Height Control Switch



NOTICE:

Do not operate the vehicle over uneven ground such as ramps, speed bumps, curbs, etc. with the air springs deflated. Doing this may lead to air bag separation from the piston, preventing the suspension air springs from re-inflating.

The air suspension height control switch is used to adjust the vehicle height to aid in coupling or uncoupling from a trailer. See Fig.157, [Air Suspension Height Control Switch](#). Setting the switch to LOWER deflates the air springs to lower the rear of the vehicle. In the NORMAL position, the air springs inflate to raise the rear of the vehicle to normal ride height.

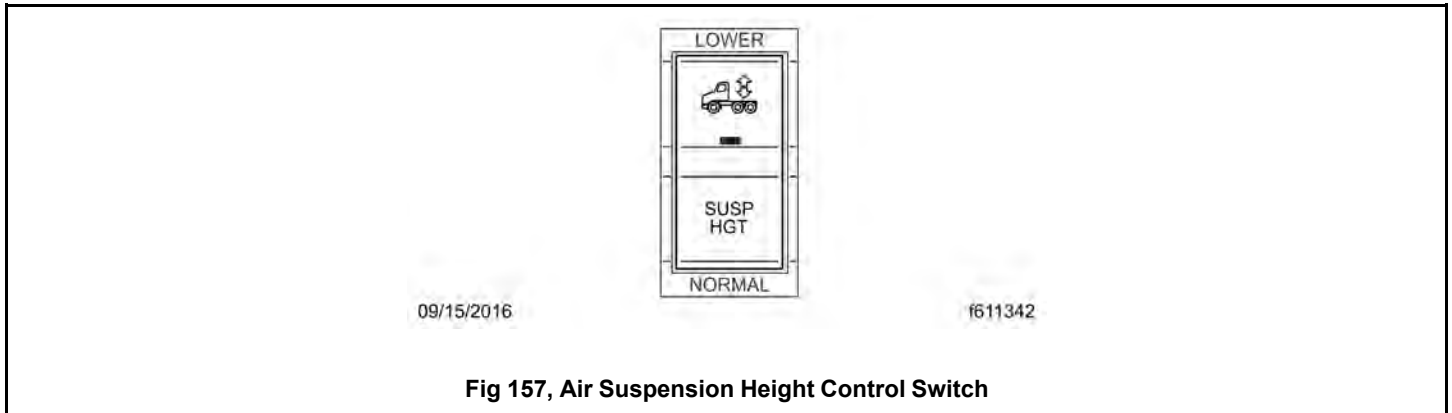

Fig 157, Air Suspension Height Control Switch



NOTICE:

Never exhaust air from the suspension while driving. When the air is exhausted, the suspension will not absorb road shocks, and components may be damaged.

A red LED in the switch is illuminated when the suspension is deflated.

5.07.02 Aerodynamic Height Control



NOTICE:

The aerodynamic height control (AHC) switch should not be used to raise the vehicle in an attempt to drive over objects in the road, as doing so will result in vehicle damage.

AHC reduces ground clearance by approximately 1 inch (2.5 cm) at highway speed. If this reduction of ground clearance is determined to be problematic, such as a construction zone or poor road conditions, AHC may be disabled. Pressing the AHC switch, shown in Fig. 158, [Aerodynamic Height Control Switch](#), disables aerodynamic lowering of the vehicle. The switch should be activated well in advance in order to avoid potential vehicle damage in these types of road conditions.

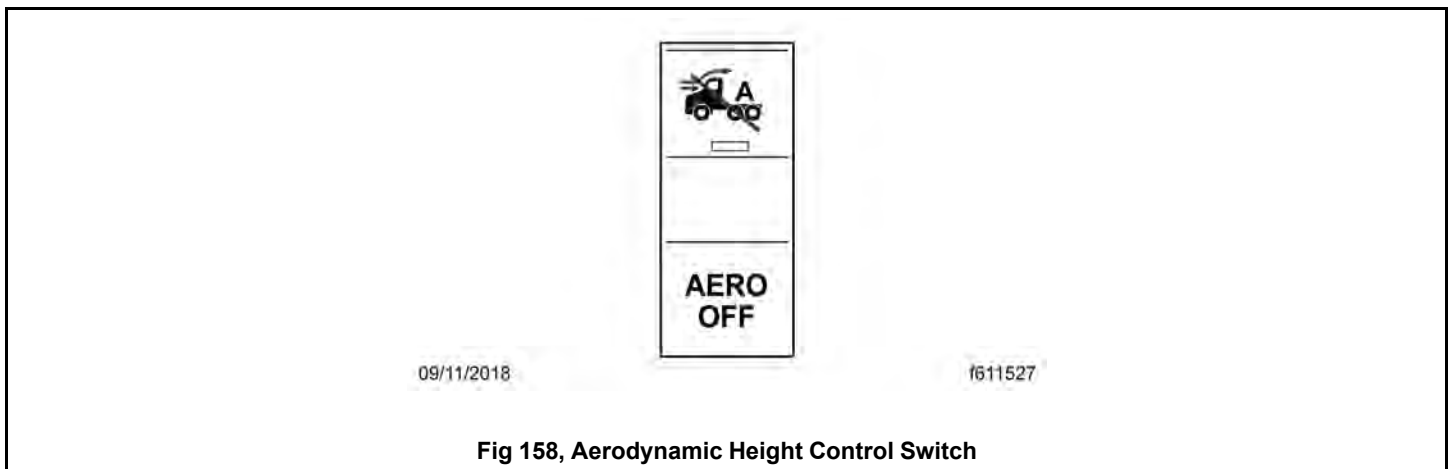
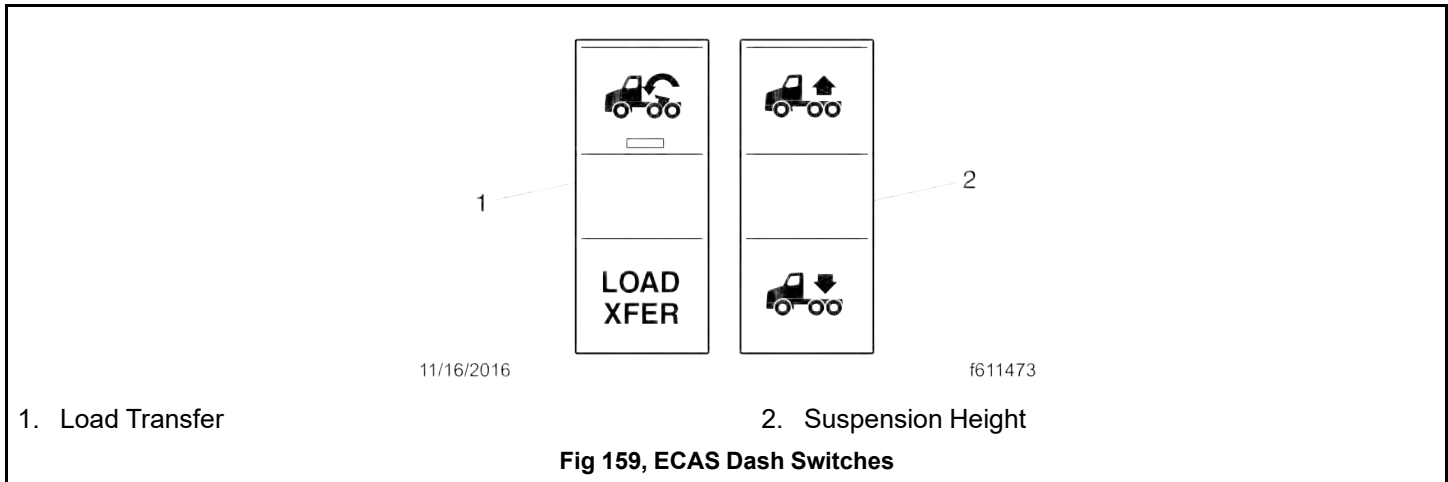

Fig 158, Aerodynamic Height Control Switch

5.07.03 ECAS Dash Switches

Vehicles with Electronically Controlled Air Suspension (ECAS) may be equipped with either dash switches or a remote control unit, not both. See Fig. 159, [ECAS Dash Switches](#) and see Table 23, [ECAS Remote Control Keys and Functions](#).

**LOAD XFER (Load Transfer)**

This switch controls the ECAS manual load transfer function by adjusting suspension air pressure. Use this function to minimize wheel slippage in road conditions where traction may be a concern.

The ECAS load transfer feature applies the maximum available vehicle load on the drive axle, up to the maximum allowable limit, determined by the gross axle weight rating (GAWR). In bobtail or with a loaded trailer less than the GAWR, the tag axle supports a negligible load while the drive axle supports nearly the full weight. Above the GAWR, the drive axle is loaded with approximately the maximum allowable load and the tag supports the remainder.

Load transfer mode can be deactivated by holding up on the dash switch for 4 seconds. Load transfer mode will automatically deactivate when the vehicle reaches 45 mph (72 km/h).

For vehicles equipped with the ICU, when load transfer mode is active, "Load Transfer" will display in the message field of the driver display. See Fig. 160, [Load Transfer Notification - ICUC](#).

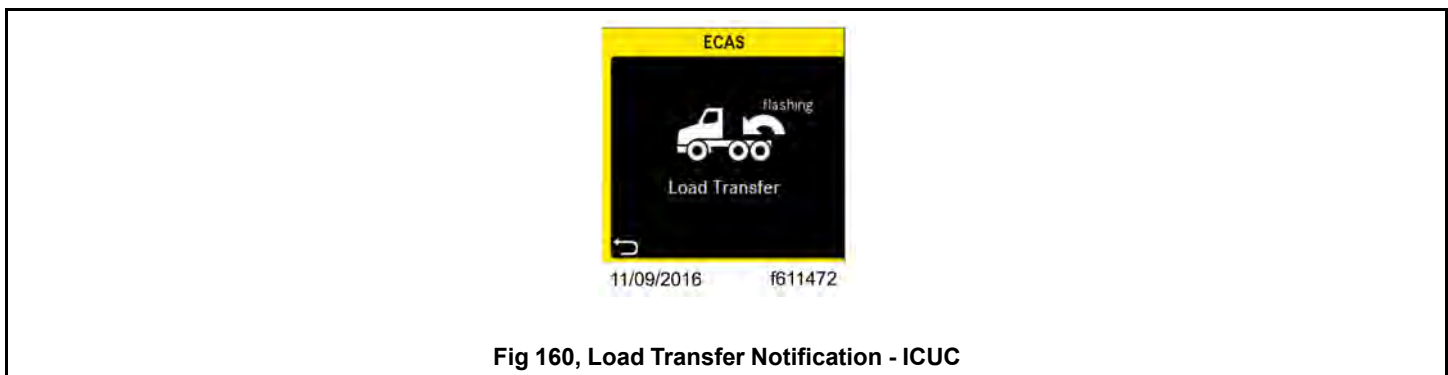
**Suspension Height**

If the suspension is at normal height:

- each up press increases the suspension height an increment, unless the suspension is at maximum height
- a down press lowers the suspension to its lowest set-point (usually axle stops)

If the suspension is **below** normal height:

- an up press increases the suspension height to normal ride height
- a down press does nothing; the suspension is already at its lowest point

If the suspension is **above** normal height:

- each up press increases the suspension height an increment, unless the suspension is at maximum height
- a down press lowers the suspension to normal ride height

On vehicles equipped with the ICU, messages about the ride height status will display in the driver display. See Fig. 161, [Example of Ride Height Message - ICUC](#) .

If the suspension is outside normal ride height (amber lamp on), the ECAS system will automatically return the suspension to normal ride height when vehicle speed reaches or exceeds a set speed (usually set to 5 mph).



ECAS Standby Mode, Dash Switch

Once the key is turned off, the ECAS will enter standby mode, remaining powered and adjusting to level and load changes for 1 hour. To cancel standby mode on vehicles with ECAS dash switches, turn the key from OFF to ON to OFF in less than 1.5 seconds. Confirm the deactivation of standby mode by pressing the suspension height switch, which should not adjust the suspension.

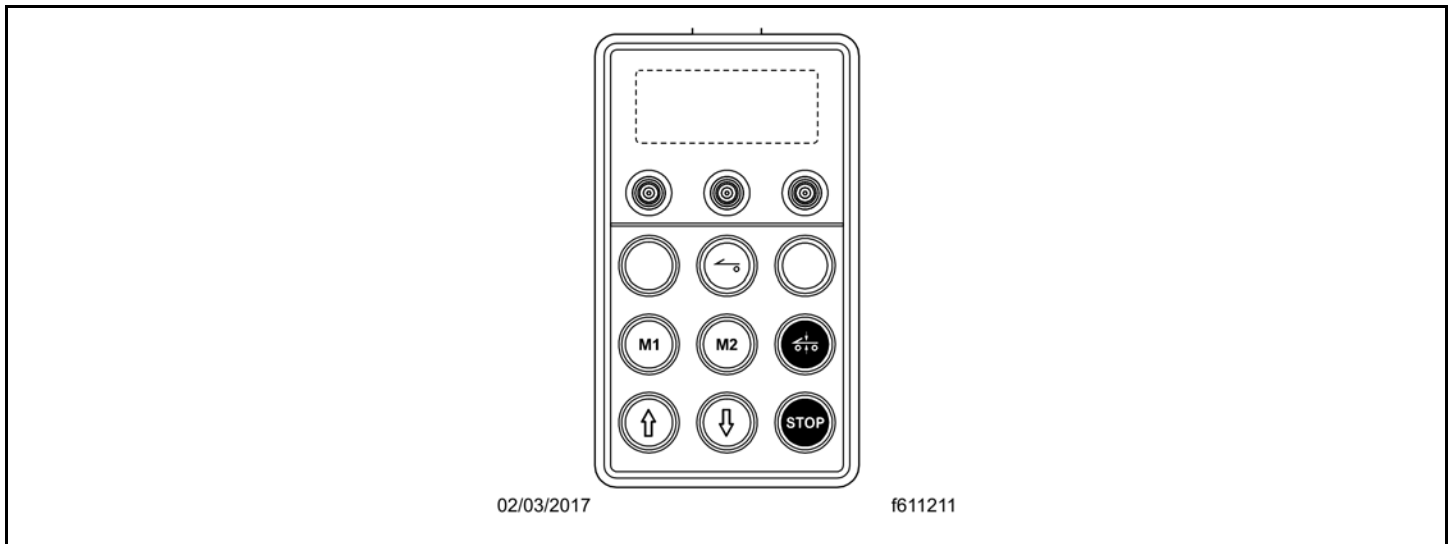

02/03/2017

f611211





| Key | Function |
|---|--|
|  | Remote Control On/Off. The middle light will remain lit while the remote is active. |
|  | Memory keys. Pressing the STOP key and a memory key simultaneously will store the current height. Once stored, pressing the key will adjust the vehicle to the stored height. |
|  | Normal height key. This key will return the vehicle to normal ride height. |
|  | Lift and lower keys. These keys will raise or lower the rear suspension height. |
|  | The STOP key. Pressing the STOP key will interrupt and stop all adjustments being made by the remote control. When the key is off, holding the Stop key for 2 seconds will cancel the 1 hour Standby mode. |

Table 23, ECAS Remote Control Keys and Functions

5.07.04 ECAS Remote Control Unit

Some vehicles equipped with Electronically Controlled Air Suspension (ECAS) have a remote control unit to lower and raise the rear suspension. See [Table 24, ECAS Remote Control Keys and Functions](#) for keys and functions.

If the suspension is outside normal ride height (amber lamp on), the ECAS system will automatically return the suspension to normal ride height when vehicle speed reaches or exceeds a set speed (usually set to 5 mph).

Messages about the ride height status will display in the ICU driver display.

ECAS Standby Mode, Remote Control

Once the key is turned off, the ECAS will enter standby mode, remaining powered and adjusting to level and load changes for 1 hour. To cancel standby mode on vehicles with a remote control, turn on the remote control then hold the STOP key on the remote for 2 seconds. Confirm the deactivation of standby mode by attempting to turn the remote on and adjust the suspension, which should not be possible.

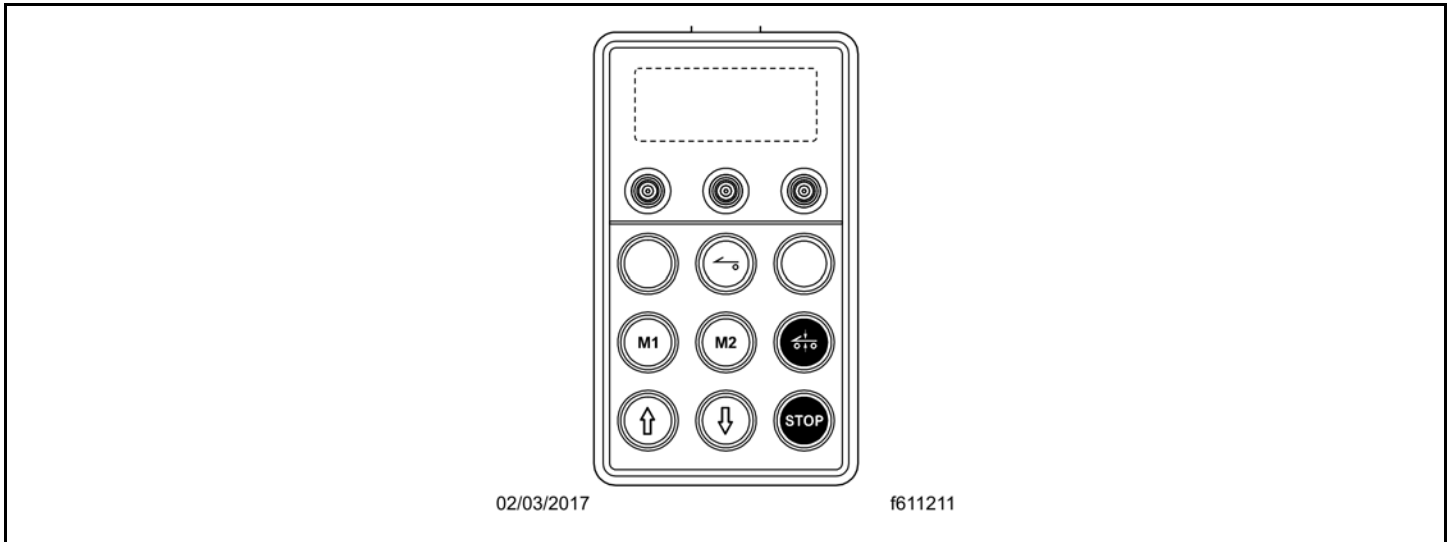

02/03/2017

f611211





| Key | Function |
|---|--|
|  | Remote Control On/Off. The middle light will remain lit while the remote is active. |
|  | Memory keys. Pressing the STOP key and a memory key simultaneously will store the current height. Once stored, pressing the key will adjust the vehicle to the stored height. |
|  | Normal height key. This key will return the vehicle to normal ride height. |
|  | Lift and lower keys. These keys will raise or lower the rear suspension height. |
|  | The STOP key. Pressing the STOP key will interrupt and stop all adjustments being made by the remote control. When the key is off, holding the Stop key for 2 seconds will cancel the 1 hour Standby mode. |

Table 24, ECAS Remote Control Keys and Functions

5.08 Fifth Wheel Controls

5.08.01 Fifth Wheel Slide Control Switch



NOTICE:

Do not activate the fifth wheel slide control valve while the vehicle is in motion. To do so could cause damage to the fifth wheel member, the kingpin, the cab or trailer, and ultimately to the drivetrain.

The fifth wheel air slide switch permits repositioning of the sliding fifth wheel from inside the cab. See Fig. 162, [Fifth Wheel Slide Control Switch](#). Moving the air slide control valve switch to the lock position deactivates the control valve and locks the fifth wheel to the baseplate. Moving the switch to the SLIDE position activates the control valve and unlocks the fifth wheel slide mechanism, allowing changes to the total length of the tractor-trailer and changes to axle loads to

comply with varying jurisdictional laws. For detailed operating instructions for fifth wheel slide, coupling, and uncoupling procedures, refer to the chapter on **Fifth Wheels**.

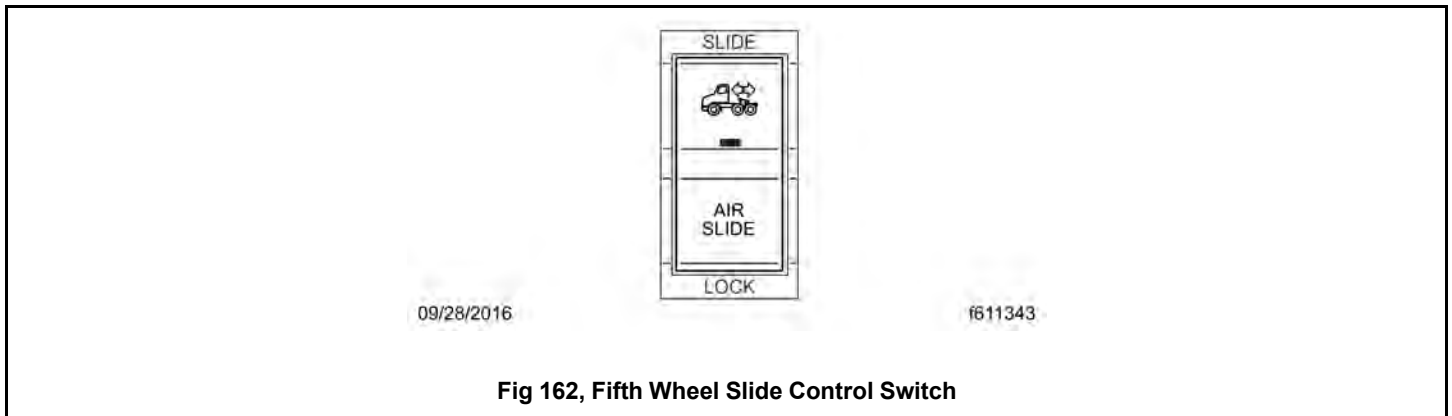

5.08.02 Trailer Auxiliary Switch

The trailer auxiliary switch energizes an optional circuit that allows the trailer electrical system to draw power for functions such as internal lights and battery charging for lift gates.

Press the top of the switch to activate the trailer auxiliary function. Press the bottom of the switch to turn trailer auxiliary function off. See Fig.163, [Trailer Auxiliary Switch](#).

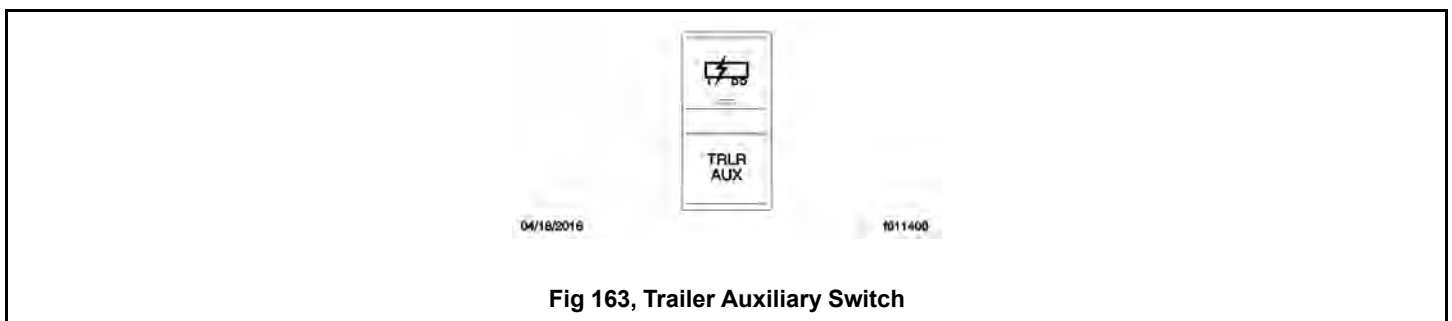

5.09 Adjustable Steering Column Controls

To unlock the steering column to adjust it, pull the steering column locking lever out and away from the column. See Fig. 164, [Unlocking the Steering Column](#). With the column unlocked, the steering wheel can be adjusted up-and-down and tilted fore-and-aft. Once the wheel is in the desired position, lock the position by pushing the lever in toward the column until it goes no further and is parallel to the column itself.



WARNING:

Make sure that the steering column is locked before driving the vehicle. Never attempt to adjust the column while driving the vehicle. Doing so could cause loss of vehicle control, personal injury, and property damage.



09/14/2016

f462301

- A. Pull the steering column locking lever out and away from the column.

Fig 164, Unlocking the Steering Column

5.10 Radio Controls

Vehicle radio controls are a mix of both physical and electronic.

Physical radio volume controls are located on the steering wheel. ICUC volume up and down switches are on the left-hand switch pod. ICC5 volume up and down buttons are on the right-hand switch pod. See Fig. 165, [Steering-Wheel-Mounted Right-Hand Pod - ICC5](#).

Other radio controls—muting the volume, choosing an audio source or radio station, or saving a station as a favorite can be done via the vehicle ICU.

For additional radio operating instructions, see the infotainment section in **Chapter 3** Instruments.

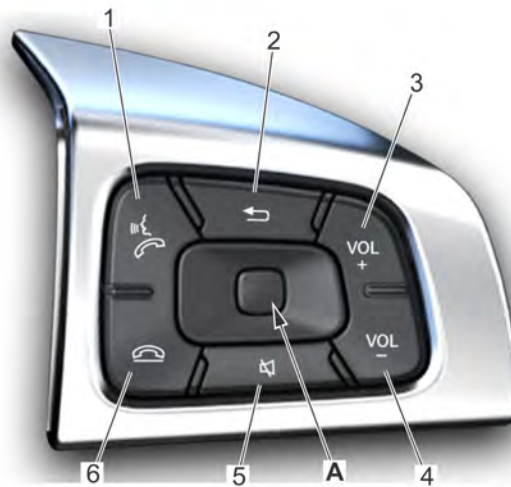

10/25/2018

f611531b

- | | |
|---|--|
| <p>A. Menu Button Press the button to access instrument panel menus. When the button is pressed, information appears on the 10-inch head unit screen.</p> <p>1. Phone Pick-Up</p> <p>2. Back Button</p> | <p>3. Volume Increment Up</p> <p>4. Volume Increment Down</p> <p>5. Mute Button</p> <p>6. Phone Hang-Up/Reject</p> |
|---|--|

Fig 165, Steering-Wheel-Mounted Right-Hand Pod - ICC5

5.11 Climate Controls

5.11.01 Cab Climate Control

NOTE: See **Chapter 8** Climate Controls for detailed climate control panel operating instructions.

NOTE: On vehicles equipped with the ICC5, the fan speed, set temperature, and ventilation mode temporarily appear on infotainment screen when these items are adjusted.

The climate control panel allows you to control the heating, ventilating, defrosting, and air conditioning (A/C) functions. The cab climate control panel has three knobs to control the functions of the cab temperature system; see Fig. 166, [Cab Climate Controls](#):

- fan knob with recirculation button
- temperature control knob with A/C button
- mode control knob (with bunk-override button on sleeper cab only)

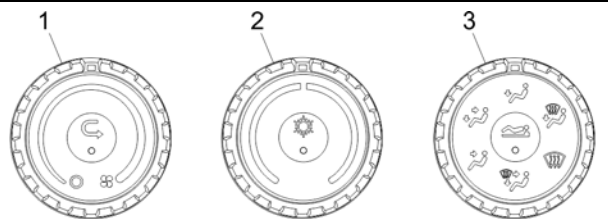

09/09/2016

f611324

- | | |
|---|-----------------------------|
| <p>1. Fan Knob</p> <p>2. Temperature Control Knob</p> | <p>3. Mode Control Knob</p> |
|---|-----------------------------|

Fig 166, Cab Climate Controls

The fan knob controls the fan speed, and forces fresh or recirculated air through the air outlets. To increase airflow, turn the knob clockwise to a higher number. To decrease airflow, turn the knob counterclockwise to a lower number.

Recirculation mode limits the amount of outside air that enters the cab. Press the recirculation button to prevent dusty or smoky air from entering the cab.

NOTE: To prevent the buildup of odors and/or oxygen depletion inside the cab, the system switches from full recirculation mode to partial recirculation mode after 20 minutes.

The temperature control knob is used to select the desired temperature. Turn the knob clockwise to the red area for warm air. Turn the knob counterclockwise to the blue area for cool air.

The A/C cools and dehumidifies the air inside the cab. Press the A/C button, located in the center of the temperature control knob, to turn the A/C on and off.

The mode control knob allows the control of air flow through the face outlets, the floor outlets, the defrost (windshield) outlets, or a combination of these outlets. See Fig.167, [Mode Control Knob With Bunk Override Button](#).

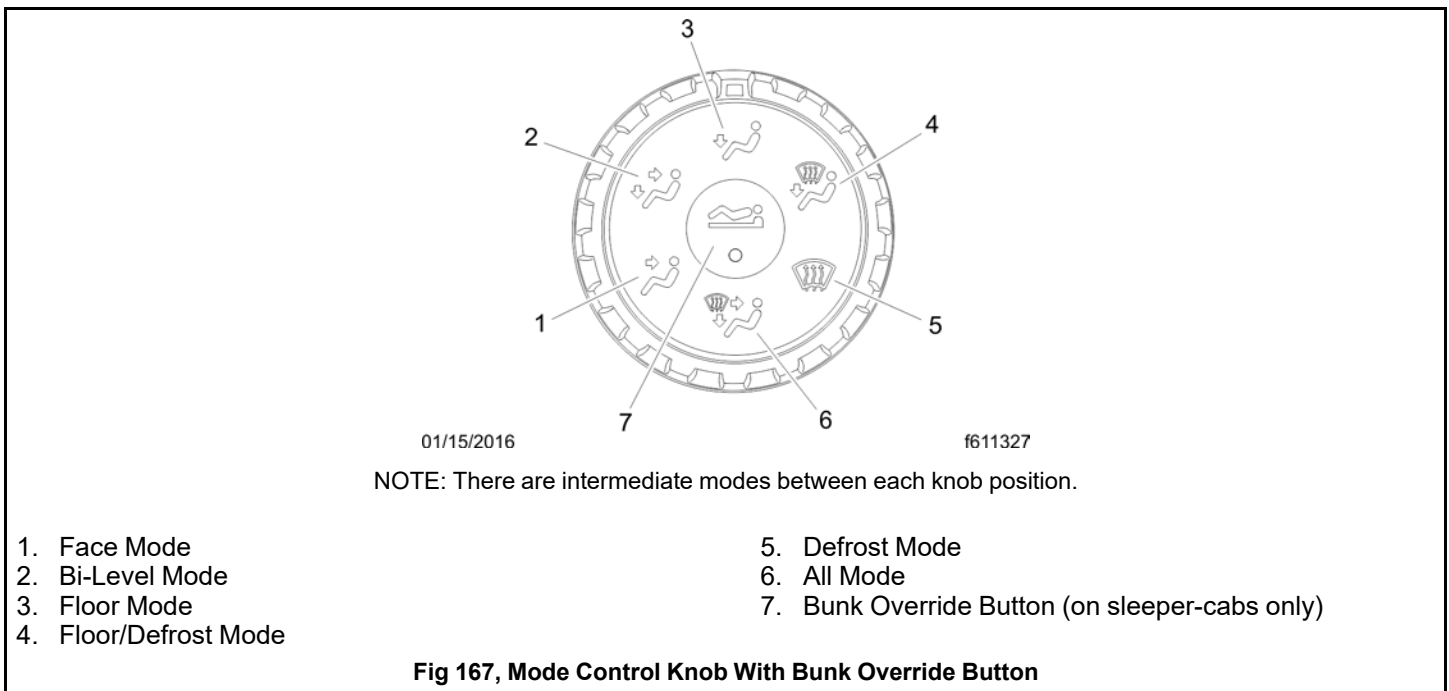

Bunk-Override Button

The bunk-override button is located in the center of the cab air-selection knob (sleeper-cabs only). See Fig. 167, [Mode Control Knob With Bunk Override Button](#). The bunk override button allows the driver to make the sleeper temperature and fan settings the same as the cab's.

Press the bunk override button to copy the current cab HVAC temperature and fan settings to the sleeper HVAC. An amber indicator will illuminate when bunk override mode is activated. When in override mode, the sleeper climate control panel automatically conforms to the fan speed and temperature settings on the cab climate panel at the time the override mode is activated. Further changes of the cab climate control settings will not alter the settings of the sleeper climate control panel.

The override mode is disabled when the fan knob or temperature control knob on the sleeper climate control panel is manually set to a different setting. The override mode is also disabled when the bunk override button is pressed to the off position.

5.11.02 Sleeper Climate Control

NOTE: See **Chapter 8** Climate Controls for detailed climate control panel operating instructions.

The sleeper temperature can be controlled from the sleeper climate control panel or from the cab climate control panel if the bunk-override button is activated.

The fan knob controls the sleeper temperature fan speed. To increase airflow, turn the knob clockwise to a higher number. To decrease the airflow, turn the knob counterclockwise to a lower number. See Fig.168, [Sleeper Climate Control Panel](#).

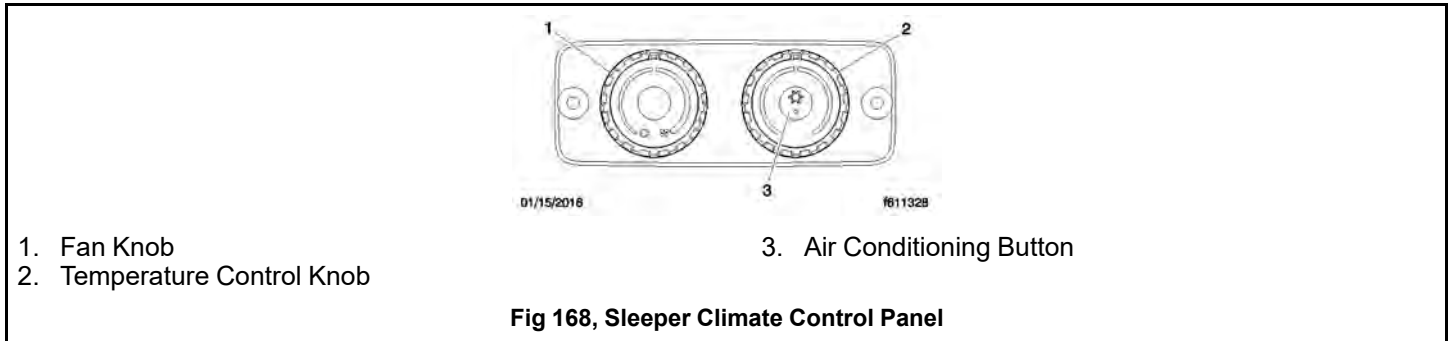

The temperature control knob is used to select the desired temperature in the sleeper. Turn the knob clockwise to the red area for warm air. Turn the knob counterclockwise to the blue area for cool air.

Press the button in the center of the temperature control knob to activate the A/C.

Cancel the bunk-override mode, if activated, by changing the sleeper fan speed or temperature setting. The system will then operate from the sleeper controls.

5.12 Seat Controls

NOTE: See [10.02.01 General Description, Seat Belts and Tether Belts](#) for detailed information about seat controls and adjustments.



WARNING:

Keep hands, tools, and other objects away from the scissor points under the seats. Failure to do so could cause personal injury.

The following is a description of adjustments that can be made to various Freightliner seats. Not all seats have all of the adjustments listed below. See Fig.169, [General Seat Adjustments](#).

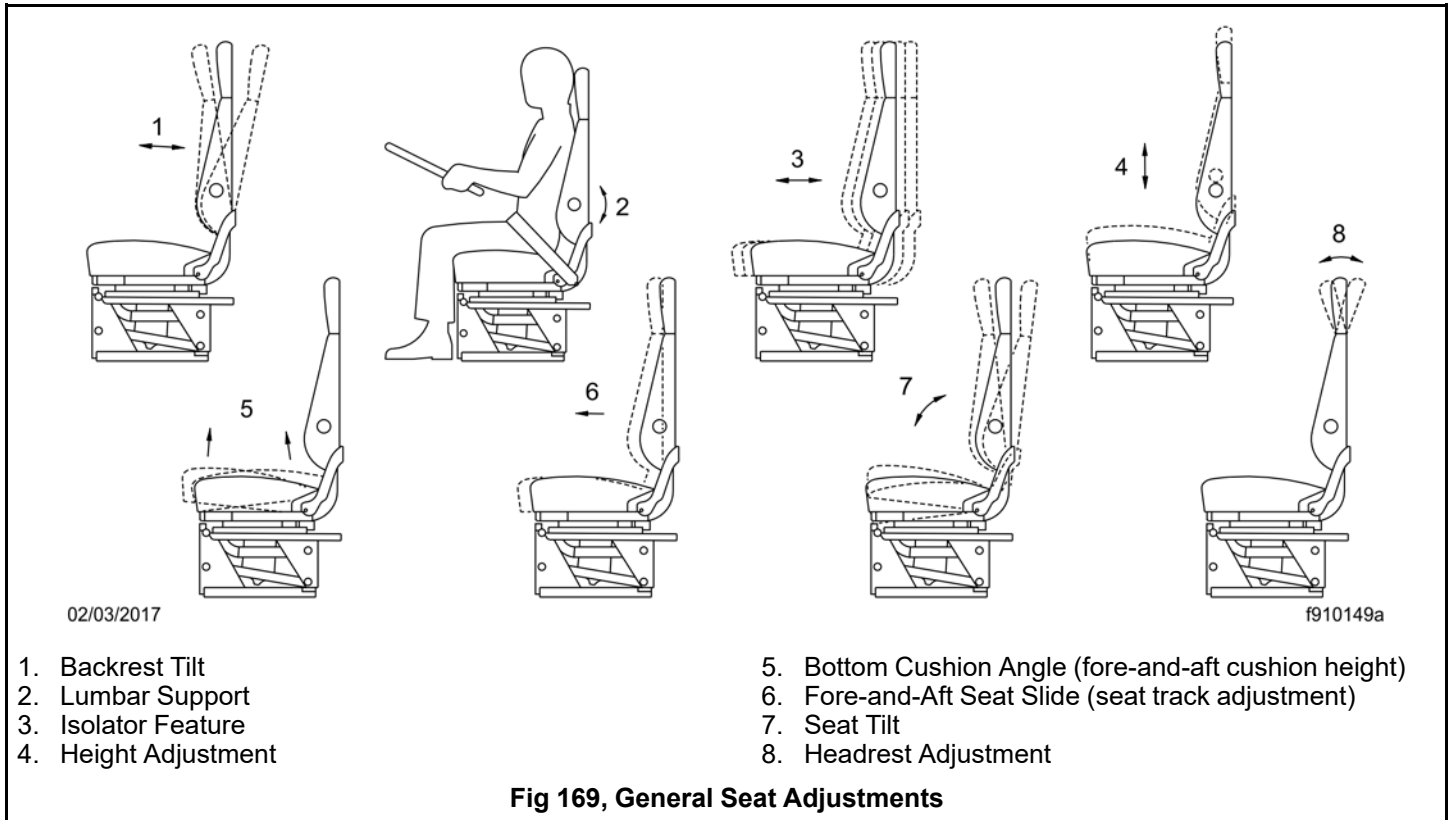

1. **Backrest Tilt:** This adjustment enables the backrest to pivot forward or backward.
2. **Lumbar Support:** Lumbar support changes the shape of the seat back to give more or less support to the occupant's lumbar (lower back) area. This adjustment is either mechanical or air controlled, depending on make and model of the seat.
3. **Isolator:** This feature reduces the amount of road shock by isolating the occupant from the motion of the vehicle, and allowing the upper seat to move in a simple pendulum motion. A lockout feature is used whenever the isolator is not desired.
4. **Height Adjustment:** This adjustment moves the entire seat up or down. The adjustment is either manually- or air-controlled, depending on the make of the seat.
5. **Bottom Cushion Angle, or Fore-and-Aft Bottom Cushion Height:** This adjustment enables the occupant to raise or lower the front or back of the bottom cushion. This adjustment is easier to perform when all weight is removed from the seat.
6. **Fore-and-Aft Seat Slide, or Seat Track Adjustment:** This adjustment moves the entire seat forward or backward on its track.
7. **Seat Tilt:** This adjustment allows the seat assembly (back and bottom cushions) to tilt forward or backward.
8. **Headrest Adjustment:** This adjustment changes the angle of the upper part of the backrest to provide head and upper back support.

| | |
|--|-----|
| 6.01 Detroit Assurance 4.0 | 194 |
| 6.01.01 General Description | 194 |
| 6.01.02 Multipurpose Camera 1 (MPC1)..... | 195 |
| 6.02 DA 4.0 Collision Mitigation System (CMS)..... | 196 |
| 6.02.01 Driver Display | 196 |
| 6.02.02 Adaptive Cruise Control (ACC)..... | 196 |
| 6.02.03 Tail Gate Warning | 200 |
| 6.02.04 Active Brake Assist (ABA)..... | 200 |
| 6.03 DA 4.0 Lane Departure Warning (LDW) | 205 |
| 6.03.01 Overview | 205 |
| 6.03.02 Lane Departure Warning (LDW) Safety Notes | 205 |
| 6.03.03 Lane Departure Warning (LDW) Functions and Activation Conditions | 206 |
| 6.03.04 Activating or Deactivating Lane Departure Warning (LDW)..... | 206 |

6. Detroit Assurance 4.0

6.01 Detroit Assurance 4.0

6.01.01 General Description

Detroit Assurance 4.0 (DA 4.0) is a driver safety system that uses a bumper-mounted radar and an optional windshield mounted camera to communicate information to the vehicle's brakes, engine, and transmission.

The system can track vehicles up to 820 feet (250 meters) ahead, and, if necessary, will sound a warning and apply the brakes.

IMPORTANT: Do not mount any attachments in front of the radar distance sensor. See Fig. 170, [Forward Radar Location](#). Do not paint or affix items over the distance sensor cover. If attachments are mounted in front of the distance sensor, such as a crash guard, they can impair the operation of the distance sensor.



To avoid malfunctions, clean the cover of the distance sensor regularly.

The windshield mounted forward-facing camera is required for DA 4.0 Lane Departure Warning (LDW). See Fig. 171, [Multipurpose Camera 1 Components](#).

The windshield must be clean, unobstructed, and without damage for proper operation of the camera. Regularly clean the area of the windshield used by the camera to avoid incorrect lane detection by LDW. The driver should switch on the windshield wiper to clean the windshield and remove snow and ice from the windshield.

If the area of the windshield used by Lane Departure Warning is damaged, the windshield must be replaced.

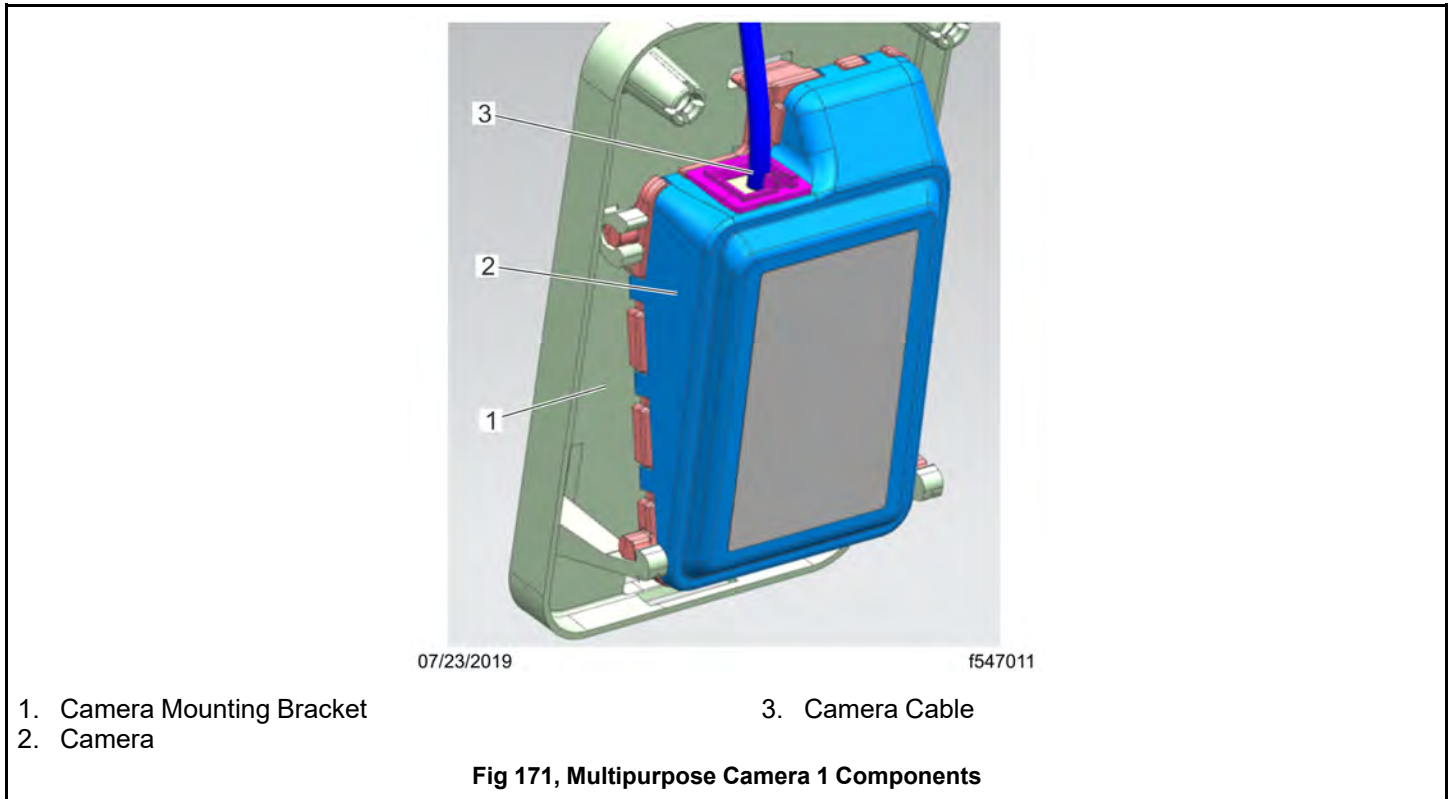

6.01.02 Multipurpose Camera 1 (MPC1)

The camera detects the raised reflectors and reflective paint in lane markings.

If the vehicle is equipped with Bendix SafetyDirect, this camera records video of the trucks activity during severe collision mitigation events. In such situations a total of 20-30 seconds of recording is transmitted to the SafetyDirect web portal.

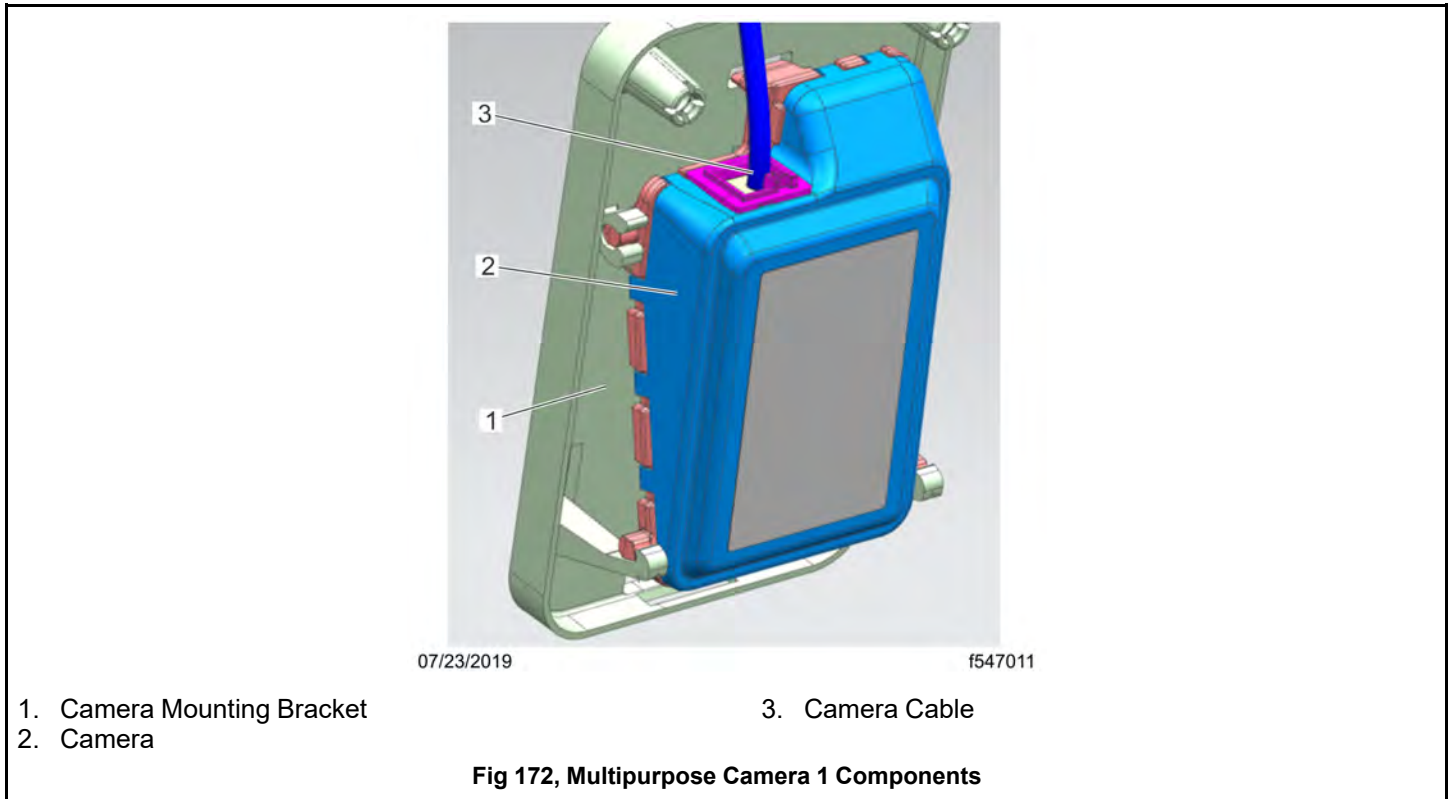

6.02 DA 4.0 Collision Mitigation System (CMS)

6.02.01 Driver Display

The driver display presents warnings and the status of adaptive cruise control (ACC) and/or lane departure warning. Refer to "Adaptive Cruise Control (ACC)" and "Lane Departure Warning (LDW)" in this chapter for more information.

To show distance, speed, and lane markings, navigate to the Quick Access menus using the steering wheel switches. Refer to **Chapter 3** for more information on instruments and driver display controls.

6.02.02 Adaptive Cruise Control (ACC)

Overview

Adaptive cruise control controls speed and the distance from a detected vehicle in front to maintain a safe following distance.

When the vehicle is traveling above 10 mph (15 km/h) and there is no vehicle in front, ACC operates in the same way as standard cruise control by accelerating to the set speed.

The default following speed of adaptive cruise control is 3.6 seconds but can be adjusted in the range of 2.4 and 3.6 seconds.

When a vehicle in front is detected, the driver display shows the speed of the detected vehicle and the distance to the detected vehicle. See Fig.173, [Adaptive Cruise Control Screen](#).



09/14/2016

f611392

Fig 173, Adaptive Cruise Control Screen

Safety Information

**WARNING:**

The Detroit Assurance system is intended solely as an aid for an alert and conscientious professional driver. It is not intended to be relied upon to operate a vehicle. Use the system in conjunction with rearview mirrors and other instruments to safely operate the vehicle.

The Detroit Assurance system is not a substitute for safe, normal driving procedures, nor will it compensate for any driver impairment such as drugs, alcohol, or fatigue.

Failure to drive safely and use the system properly could result in personal injury and/or death and severe property damage.

Operate a vehicle equipped with the Detroit Assurance system as if the vehicle were not equipped with a collision warning system.

Adaptive cruise control (ACC) may not detect narrow vehicles, like motorcycles, driving in front of the vehicle, or vehicles driving in a different lane.

In particular, be aware of the following situations:

- cornering, entering, and exiting bends;
- vehicles driving in a different lane;
- vehicles changing lanes;
- vehicles exiting the road;
- overtaking;
- winding stretches of road; and

- obstacles and stationary vehicles.

Adaptive cruise control does not compensate for inattentive driving, weather, or traffic conditions. Adaptive cruise control is only an aid. The driver is responsible for maintaining a safe distance from the vehicle in front, maintaining a safe vehicle speed, braking, and remaining in a lane.

ACC Controls

See Fig. 174, [Steering-Wheel-Mounted Switches](#) and see Table 25, [Steering Wheel Controls](#) for a description of cruise control steering wheel switches.

| Description | Function |
|-------------|---|
| /SET | Sets the cruise speed while the vehicle is traveling at the desired speed. Pressing and holding decreases the set cruise speed. |
| +/RES | Resumes the set speed. Pressing and holding increases the set cruise speed. |
| CNCL | Deactivates cruise control, but retains the set speed in memory. |

Table 25, Steering Wheel Controls

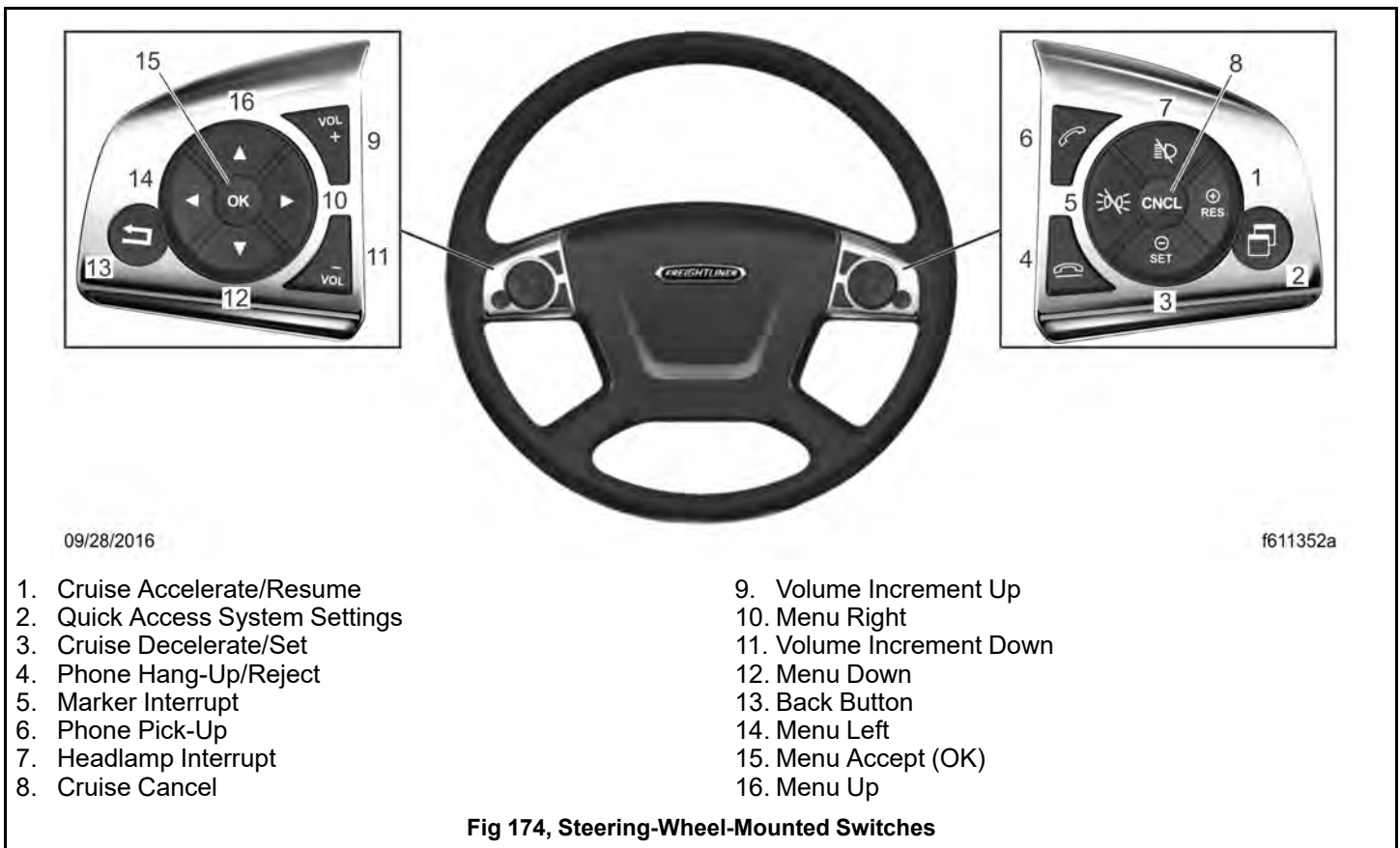

Functions and Activation Conditions

If ACC detects a vehicle in front driving at a speed slower than the set cruise speed, the engine is derated, the engine brakes are activated, and the service brakes are applied, slowing the vehicle to maintain the minimum following distance. If

the vehicle in front is no longer detected, the vehicle will accelerate to the set speed. The ACC will also slow the vehicle if it exceeds the set speed (on a downhill grade, for example).

Adaptive cruise control cannot be activated, or is automatically deactivated, if:

- the vehicle is traveling slower than 10 mph (15 km/h);
- the transmission is in neutral for more than 5 seconds;
- reverse gear is selected;
- ABS is deactivated;
- there is a malfunction in the brake system or the electronic management system; or
- the distance sensor initialization is not yet complete.

Activating Adaptive Cruise Control and Setting the Speed

Activate ACC by setting the cruise speed, using the controls on the steering wheel. See Table.25, [Steering Wheel Controls](#).

Drive at the desired speed, then press the /SET switch. Adaptive cruise control will be activated and the set speed stored.

If the brake pedal is pressed, ACC is automatically deactivated.

If ACC is deactivated, the stored speed can be activated again by pressing the +/RES switch. The driver display will show the adaptive cruise control symbol and the set speed. Adaptive cruise control will automatically brake or accelerate the vehicle to maintain the set speed.

If ACC is, or becomes, unavailable, a message will be displayed that allows the driver to choose to use standard cruise control. See Fig.175, [ACC Unavailable](#).

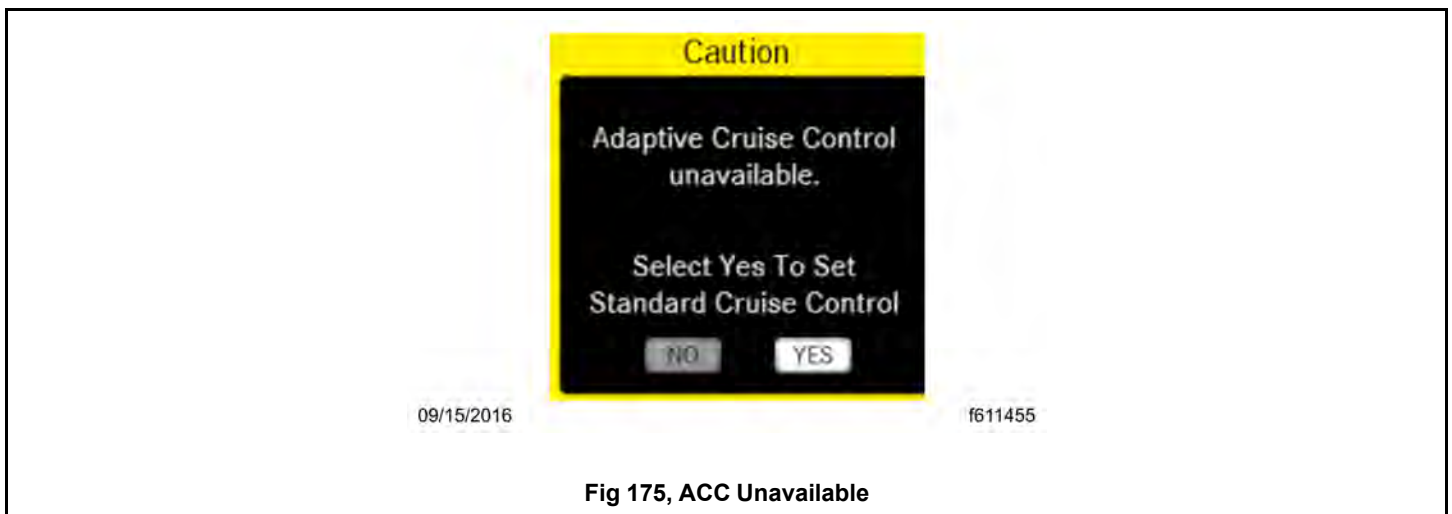

Fig 175, ACC Unavailable

Increasing or Reducing Speed

The speed setting can only be set when driving.

Press /SET to set the cruise speed while the vehicle is traveling at the desired speed. Press and hold to decrease the set cruise speed.

Setting the Distance to the Vehicle in Front

The ACC settings menu can be used to set the distance to the vehicle in front.

IMPORTANT: Make sure that the minimum distance is maintained to the vehicle in front required by law. Adjust the specified minimum distance to the vehicle in front if necessary.

Collision Warning

NOTE: If the accelerator pedal is pressed, or a turn is indicated, the collision avoidance system is suppressed.

In the event of a potential collision, a warning appears on the driver display screen and a double warning tone sounds. The warning screen is displayed for as long as the hazardous situation persists.

If a collision warning appears on the driver display screen, pay attention to the traffic situation and reduce the vehicle speed using the service brake.

Overtaking

NOTE: It is possible to exceed the set speed when overtaking.

The set speed can be exceeded using the accelerator pedal. When the accelerator pedal is released, the set speed will be resumed.

Deactivating the System

Press the CNCL switch, or, press the brake pedal to deactivate cruise control.

NOTE: The set speed remains stored when ACC is deactivated.

6.02.03 Tail Gate Warning

Tale Gate Warning uses the vehicle's bumper mounted radar to calculate a safe following distance at speeds greater than 20 mph (32 kp/h). The system will present a visual alert if the driver is following the vehicle in front too closely. The system warns the driver when:

- ACC is not activated;
- the vehicle is moving faster than 20 mph (32 kp/h); and
- the driver follows a vehicle for longer than 10 seconds at a distance that will be traversed in less than 2.6 seconds.

The system will not give warning when:

- the vehicle is moving slower than 20 mph (32 km/h);
- another vehicle cuts in front;
- the vehicle in front is moving away: or
- ACC is activated.

After the initial warning, the system will continue to warn the driver every 20 seconds if the gap between the vehicles does not increase.

Tail gate warning operates independently from active brake assist (ABA).

Once activated, Tailgate Warning will deactivate only at speeds less than 20mph (32 km/h).

6.02.04 Active Brake Assist (ABA)

Overview

Active Brake Assist is always on, automatically tracking the distance from the front of the tractor to other vehicles in its path using bumper-mounted radar.

The radar tracks stationary objects in the vehicle's path and has the capacity to engage full braking on these objects, such as a parked vehicle or stopped traffic.

The radar system can detect most pedestrians moving within the vehicle's path as long as they stay in motion; the system can act to help mitigate a collision at vehicle speeds below 25mph (40 km/h). If the system detects a pedestrian in motion within the radar system's parameters for potential danger, the vehicle will give a visual and auditory warning, and, if the driver doesn't respond, engage in partial braking.

The radar may not detect pedestrians in every possible situation, nor is it a substitute for cautious driving.

Safety Information

**WARNING:**

Active Brake Assist (ABA) is intended only as an aid for a conscientious and alert driver. The driver is responsible for keeping a safe distance from the vehicle in front, for the vehicle speed, braking in good time, and remaining in lane.

ABA does not take road and weather conditions into account, nor the prevailing traffic situation. The driver should always adapt driving style to suit prevailing road and weather conditions.

ABA is not a substitute for safe driving procedures.

Operate a vehicle equipped with Detroit Assurance Collision Mitigation System as if the vehicle were not equipped with a collision mitigation system.

The Detroit Assurance Collision Mitigation System will not warn of hazards such as animals, oncoming vehicles, or cross traffic.

Failure to drive safely and use the system properly could result in personal injury and/or death and severe property damage.

If your vehicle is equipped with ABA, it can (within system limitations):

- react more quickly to an object in your path of travel;
- perform emergency braking; and
- react to moving people with a warning and partial braking.

Active brake assist can minimize the risk of a front-end collision with a moving or stationary vehicle. If ABA detects the risk of a front-end collision, it issues an audible and visual warning. If the risk persists, ABA automatically initiates partial braking of the vehicle. If the driver does not react to the warnings and partial brake application, ABA automatically initiates a full brake application.

Active brake assist may detect moving people within the vehicle's path and along the edge of the lane and can act to help mitigate a collision at speeds below 25mph (40 km/h).

Active brake assist may not detect narrow vehicles, like motorcycle, driving in front, or vehicles driving on a different lane.

Active brake assist does not automatically adapt to road and traffic conditions. Brake the vehicle using the service brake if:

- an event window with the warning symbol appears on the driver display screen;
- an intermittent warning tone sounds; or
- an intermittent warning tone sounds and automatic partial braking was initiated.

If no visual and/or acoustic warning is issued in a critical situation:

- Active brake assist has not recognized the danger of the situation; or
- Active brake assist is suppressed; or
- Active brake assist has failed.

Active brake assist-triggered emergency braking can be deactivated if the driver presses the accelerator pedal beyond the pressure point (kickdown).

IMPORTANT: If there is risk of a collision, adaptive cruise control (ACC) may warn the driver before active brake assist (ABA).

Collision Warning and Emergency Braking

If there is a risk of collision, ABA issues alerts on the driver display, sounds an audible warning, and illuminates the ABA indicator lamp on the dash. See Fig. 176, [ABA Indicator Lamp](#). In addition, the radio and/or hands-free systems like Detroit Connect are muted. The ABA series of warnings is as follows:

- **Warning (ABA):** An alert appears on the driver display and an intermittent warning tone sounds.
- **Partial Braking (ABA):** If the driver does not respond, the system pulses the brakes while presenting a visual alert on the dash and sounding a solid warning tone. At this point ABA brakes the vehicle with around 50% of the vehicle's maximum braking power.
- **Emergency braking (ABA):** If the driver does not react to the collision warnings or partial brake application, ABA automatically initiates emergency braking (full brake application). The warning message appears on the driver display, and a continuous warning tone sounds.

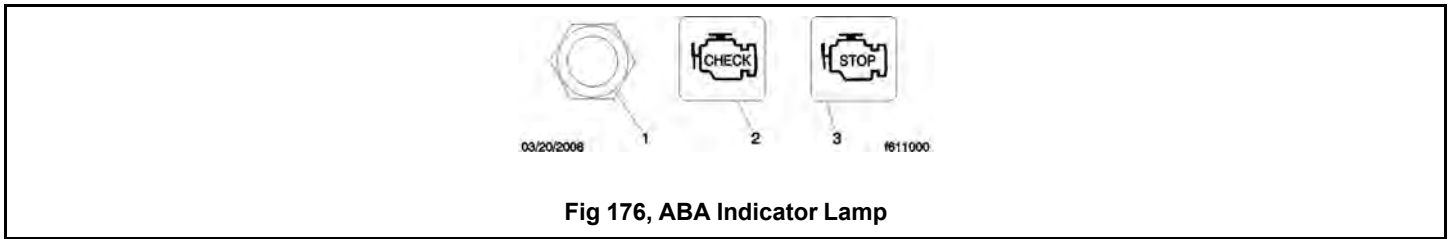

CAUTION:

After emergency braking, the vehicle is held by the service brake for up to 5 seconds to prevent it from rolling away.

After an emergency braking maneuver has been performed, retake control of the vehicle as soon as possible and, paying attention to the traffic situation, remove the vehicle from the area of danger. Stop the engine and apply the parking brake. Inspect the vehicle to ensure it is in proper operating order and confirm the load is secured before resuming driving.

Always apply the parking brake upon shutting the engine off or prior to exiting the vehicle.

The driver can interrupt emergency braking by pressing the accelerator pedal beyond the point of resistance (kickdown).

Driving Situations

See Table 26, [Active Brake Assist Limitations](#) for a description of adaptive cruise control and active brake assist limitations in specific driving conditions.

| Condition | Visual | Description |
|--|----------------------------|--|
| <p>Cornering, entering and exiting bends</p> | <p>12/18/2014 f040840a</p> | <p>The ability of ABA and ACC to detect vehicles on bends is limited.</p> <p>ABA and ACC may unexpectedly issue warnings or brake the vehicle.</p> <p>ACC may also accelerate the vehicle unexpectedly.</p> |
| <p>Driving in a different lane, and stationary vehicles</p> | <p>12/18/2014 f040835a</p> | <p>The ability of ABA and ACC to detect vehicles driving in a different lane is limited.</p> <p>ABA and ACC may unexpectedly issue warnings or brake the vehicle.</p> <p>ACC may also accelerate the vehicle unexpectedly.</p> <p>With Active Brake Assist 4.0, the radar tracks stationary objects and has the capacity to engage full braking on</p> |

Table 26, Active Brake Assist Limitations



| Condition | Visual | Description |
|---|--|--|
| | | these objects, such as a parked vehicle or stopped traffic in the vehicle's path. |
| Other vehicles changing lane |  <p>12/18/2014 f040836a</p> | <p>The ability of ABA and ACC to detect vehicles pulling into your lane without maintaining a safe distance is limited. The distance to the vehicle in front entering your lane may be too short.</p> <p>ABA may unexpectedly issue warnings or brake the vehicle.</p> |
| |  <p>12/18/2014 f040841a</p> | <p>The ability of ABA and ACC to detect vehicles pulling into your lane without maintaining a safe distance is limited. They do not detect vehicles until they are within the radar's detection range.</p> <p>If the vehicle is too narrow, ACC may accelerate unexpectedly. Brake the vehicle to increase the distance to the vehicle in front.</p> |
| Vehicles turning off |  <p>12/18/2014 f040843a</p> | <p>The ability of ABA and ACC to detect vehicles turning off is limited.</p> <p>ABA and ACC may unexpectedly issue warnings or brake your vehicle.</p> |
| Overtaking |  <p>12/18/2014 f040838a</p> | <p>When passing, ABA and ACC may unexpectedly issue warnings or brake your vehicle if your vehicle is too close to the vehicle in front and is in the same lane.</p> |
| Winding stretches of road |  <p>12/18/2014 f040844a</p> | <p>On winding stretches of road, ABA and ACC cannot detect which lane the vehicle in front is driving in.</p> <p>ABA and ACC may unexpectedly issue warnings or brake your vehicle.</p> <p>ACC may also accelerate the vehicle unexpectedly.</p> |
| Obstacles and stationary vehicles in front of the tracked vehicle |  <p>12/18/2014 f040837a</p> | <p>ABA and ACC cannot detect obstacles or stationary vehicles in front of the detected vehicle.</p> <p>ABA and ACC may unexpectedly issue warnings or brake your vehicle.</p> <p>ACC may also accelerate the vehicle unexpectedly.</p> |

Table 26, Active Brake Assist Limitations

| Condition | Visual | Description |
|----------------------------------|--|--|
| <p>Stationary objects</p> |  <p>12/18/2014 f040842a</p> | <p>ABA may unexpectedly issue warnings and brake the vehicle if it detects stationary objects like:</p> <ul style="list-style-type: none"> • vehicles which have broken down • parked or stopped vehicles • signs • bridges |
| <p>Stationary people</p> |  <p>09/14/2016 f040847</p> | <p>ABA can react incorrectly to the following conditions:</p> <ul style="list-style-type: none"> • stationary people • people or objects that quickly enter the field of detection of the sensor • people in a tunnel <p>ABA can also react unexpectedly to people who are standing on the roadside in a curve.</p> |

Table 26, Active Brake Assist Limitations

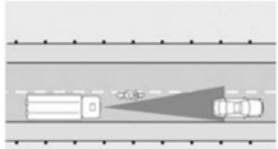
Activating/Deactivating Active Brake Assist

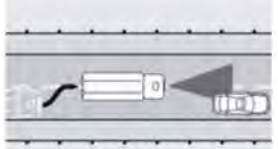
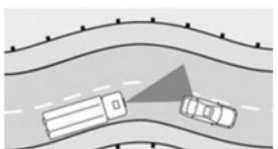
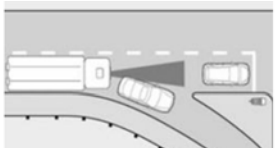
The ABA system cannot be turned off. However, ABA is suppressed when the driver:

- uses the turn signal during an audible warning;
- rapidly presses the accelerator; or
- presses the accelerator pedal beyond the pressure point (kickdown).

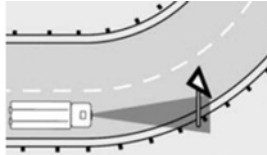
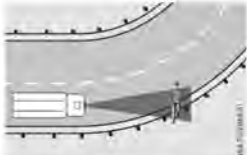
If there is a system error, the indicator lamp will illuminate and an alert will be shown on the driver display. See Fig. 177, [ABA Unavailable Indicator Lamp](#) and Fig. 178, [ABA Alert Popup](#).



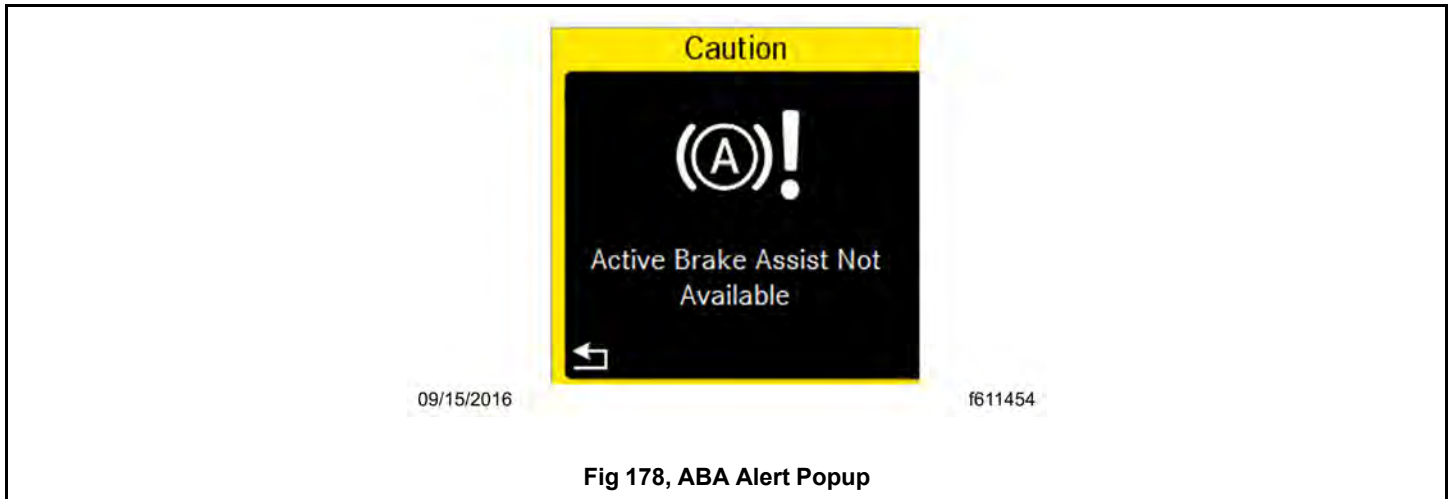

Fig 178, ABA Alert Popup

6.03 DA 4.0 Lane Departure Warning (LDW)

6.03.01 Overview

NOTE: Lane departure warning is optional with Detroit Assurance 4.0.

Lane departure warning monitors the area in front of the vehicle with a camera on the top of the windshield. When lane departure warning is active and detecting lane markings on the road surface, it visually and audibly warns the driver if it thinks the vehicle may be leaving the lane unintentionally. Lane departure warning only needs one identifiable lane line to function.



WARNING:

The lane departure warning system is intended only as an aid for a conscientious and alert driver. Do not rely on the system to safely operate the vehicle.

The system may not indicate lane departures under certain conditions. Read the information in this manual to understand the circumstances under which this system may not provide adequate lane departure warnings.

The system does not warn of all possible hazards. For example, the system cannot prevent an accident if the driver is impaired or not driving safely.

The lane departure warning system is not a substitute for safe driving procedures.

Failure to drive safely and use the system properly could result in personal injury and/or death and severe property damage.

6.03.02 Lane Departure Warning (LDW) Safety Notes

NOTE: Lane departure warning is optional with Detroit Assurance 4.0.

The system may be impaired or may not operate in the following situations:

- when there is low visibility due to insufficient road illumination, or due to snow, rain, fog or heavy spray
- when there is glare due to oncoming traffic, direct sunlight, or reflections from wet road surfaces
- when the windshield in the area of the camera is dirty, misted up, damaged or covered by a sticker
- when no lane markings or several varied lane markings are present, such as in a construction zone
- when the lane markings are worn, dark, or covered, such as by sand, dirt, or snow
- when the distance from the vehicle in front is too small and this prevents the lane markings from being detected
- when the lane markings change rapidly, when lanes branch off, or when they cross or merge

- when lanes are very narrow or winding
- when shade conditions on the road surface change greatly

The driver must adapt their driving style to current conditions. Lane departure warning cannot take the road and weather conditions into account, nor the prevailing traffic situation. The driver is responsible for the distance to the vehicle in front, for vehicle speed, braking in good time and remaining in the lane.

6.03.03 Lane Departure Warning (LDW) Functions and Activation Conditions

NOTE: Lane departure warning is optional with Detroit Assurance 4.0.

The Detroit Assurance LDW system is designed to warn the driver as the vehicle crosses the outer boundary of the lane marking. This may differ from other LDW systems which issue a warning as the driver approaches the inside of the lane marking. If the system warns at, or just beyond the outer edge of the lane marking, the system is performing as designed. If the warning does not occur, or occurs after an excessive lane departure, the system may not be operating properly.

In addition to acting as a warning, lane markings on the driver display screen show the status of lane departure warning. No lane markings or outlined lane markings indicate that LDW is off. Solid white or red lane markings indicate LDW is active.

Lane departure warning only issues warnings if the speed is above approximately 37 mph (60 km/h).

When driving over lane markings unintentionally, the volume of audio equipment like the radio and/or hands-free systems is muted and a direction-related "rumble-strip noise" sounds from either the left or right door speaker.

NOTE: While the LDW audio alert is expected to sound through the radio speakers on any unit with a properly installed system, the LDW alert will only mute the radio output if the radio is both capable of supporting a mute feature and is properly configured.

Lane departure warning does not issue a warning if:

- the turn signals are switched on;
- there is braking or acceleration; or
- a driving safety system such as Active Brake Assist (ABA), Stability Control, or Adaptive Cruise Control (ACC) intervenes.

6.03.04 Activating or Deactivating Lane Departure Warning (LDW)

NOTE: Lane departure warning is optional with Detroit Assurance 4.0.

NOTE: There is no audible self-test of the "rumble-strip noise" of the LDW when the key is turned on.

When the engine is turned on, LDW is automatically activated.

Pressing the LDW OFF switch will deactivate lane departure warning temporarily. See Fig.179, [LDW Switch](#).

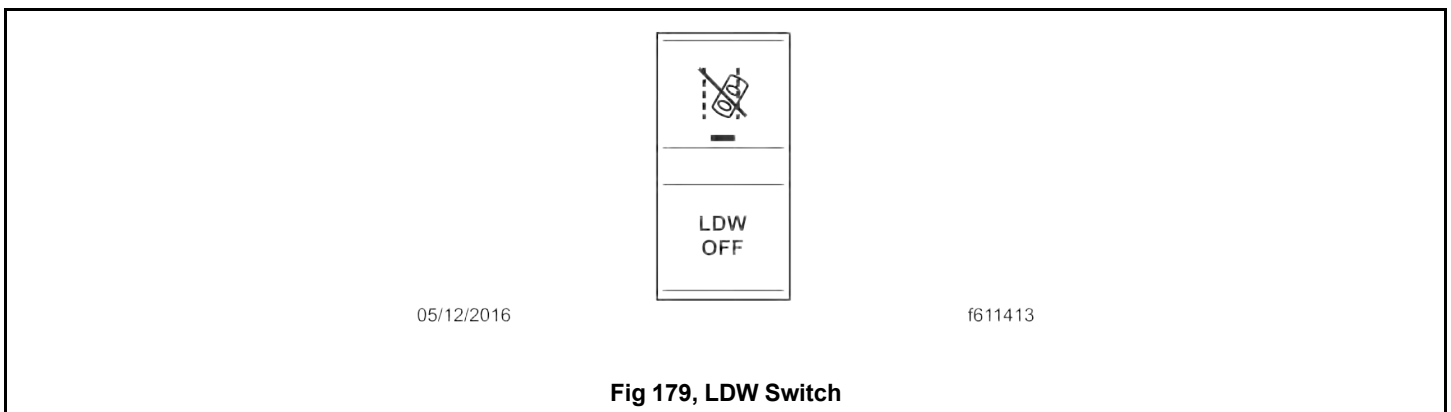

Lane departure warning is not active if:

- the driver presses the LDW OFF switch; or
- the system is searching for a lane.

If there is a system error, the LDW telltale will illuminate in the driver display. See Fig.180, [LDW Telltale - ICUC](#).



| | |
|--|-----|
| 7.01 Detroit Assurance Collision Mitigation System (CMS) Overview | 211 |
| 7.01.01 General Description | 211 |
| 7.01.02 Driver Display | 211 |
| 7.02 Detroit Assurance Vehicle Cameras | 212 |
| 7.02.01 Multipurpose Camera 2 (MPC2) | 212 |
| 7.02.02 Driver Facing Camera | 213 |
| 7.02.03 Rain Light Sensor | 213 |
| 7.02.04 Bendix Forward Facing Camera | 213 |
| 7.03 Detroit Assurance Adaptive Cruise Control (ACC) | 214 |
| 7.03.01 Adaptive Cruise Control Safety Information | 214 |
| 7.03.02 Adaptive Cruise Control Overview | 215 |
| 7.04 Detroit Assurance Tailgate Warning | 218 |
| 7.05 Detroit Assurance Active Brake Assist 5 (ABA5) | 219 |
| 7.05.01 Active Brake Assist 5 Overview | 219 |
| 7.05.02 Active Brake Assist 5 Safety Information | 219 |
| 7.05.03 Activating and Deactivating Active Brake Assist 5 | 220 |
| 7.05.04 Active Brake Assist 5 Collision Warning and Emergency Braking | 221 |
| 7.05.05 Overriding ABA Events | 222 |
| 7.06 Limitations of Detroit Assurance ABA5 and ACC | 223 |
| 7.07 Detroit Assurance Lane Departure Warning (LDW) | 226 |
| 7.07.01 Lane Departure Warning Safety Information | 226 |
| 7.07.02 Lane Departure Warning Overview | 227 |
| 7.07.03 Functions and Activation Conditions for Lane Departure Warning | 228 |
| 7.07.04 Activating or Deactivating Lane Departure Warning (LDW) | 229 |
| 7.07.05 Cleaning the Windshield in the Area of the Camera | 231 |
| 7.08 Detroit Assurance Active Lane Assist (ALA) | 231 |
| 7.08.01 Active Lane Assist Safety Information | 231 |
| 7.08.02 Active Lane Assist Overview | 232 |
| 7.08.03 Active Lane Assist Activation Conditions | 233 |
| 7.08.04 Active Lane Assist (ALA) Functions and Warnings | 236 |
| 7.08.05 Active Lane Assist (ALA) Switches | 239 |

| | |
|--|-----|
| 7.09 Detroit Assurance Side Guard Assist (SGA) and Active Side Guard Assist (ASGA) | 241 |
| 7.09.01 General Information | 241 |
| 7.09.02 Safety Information..... | 243 |
| 7.09.03 Sensor Monitoring Range | 243 |
| 7.09.04 SGA Indicator Lamps | 243 |
| 7.09.05 Side Guard Assist Activation Conditions | 245 |
| 7.09.06 Warnings for Moving Objects | 248 |
| 7.09.07 Warnings When Turning Right | 248 |
| 7.09.08 Warnings When Changing Lanes | 249 |
| 7.09.09 Warnings When Turning Right for Stationary Obstacles | 250 |
| 7.09.10 Activating or Deactivating Side Guard Assist..... | 250 |
| 7.10 Detroit Assurance Traffic Sign Display | 250 |
| 7.10.01 General Information | 250 |
| 7.10.02 Safety Information..... | 250 |
| 7.10.03 Traffic Sign Display Functionality..... | 251 |
| 7.10.04 Activating or Deactivating | 252 |
| 7.11 Detroit Assurance Attention Assist | 253 |
| 7.11.01 General Information..... | 253 |
| 7.11.02 Safety Information | 253 |
| 7.11.03 Function and Activation Conditions..... | 253 |
| 7.11.04 Activating or Deactivating | 254 |
| 7.12 Lytx SF500 DriveCam System..... | 254 |
| 7.12.01 Driver Facing Camera | 254 |

7. Detroit Assurance

7.01 Detroit Assurance Collision Mitigation System (CMS) Overview

7.01.01 General Description

The Detroit Assurance collision mitigation system (CMS) is a safety system that uses a radar mounted on the front frame crossmember, shown in Fig.181, [Forward Radar Location](#), and a windshield-mounted multipurpose camera to communicate information to active features that can control the truck.

The system can track vehicles up to 820 ft (250 m) ahead, and, if necessary, sound a warning and apply the brakes.



IMPORTANT: Do not mount any attachments in front of the radar distance sensor. Do not paint or affix items over the distance sensor cover. Keep the cover free of mud, ice, and snow. Attachments mounted in front of the distance sensor, such as a crash guard, and objects on the sensor cover can impair the operation of the distance sensor.

7.01.02 Driver Display

The driver display presents the status and warnings from the different features that make up the Detroit Assurance safety system.

The standard core features of Detroit Assurance on the New Cascadia include active brake assist (ABA), adaptive cruise control (ACC), tailgate warning, lane departure warning (LDW), and side guard assist (SGA).

Optional features include active lane assist (ALA) with lane keep assist (LKA), lane departure protection (LDP), auto stop, and active side guard assist (ASGA).

If the vehicle is equipped with an ICUC, the right-hand steering wheel switch pod, shown in Fig.

182, [Steering-Wheel-Mounted Right-Hand Switch Pod - ICUC](#), contains adaptive cruise control (ACC) controls and access to Detroit Assurance settings via the 'quick access system settings' button. If the vehicle is equipped with an ICC5, these controls are on the left-hand steering wheel switch pod shown in Fig.183, [Steering-Wheel-Mounted Left-Hand Pod - ICC5](#).

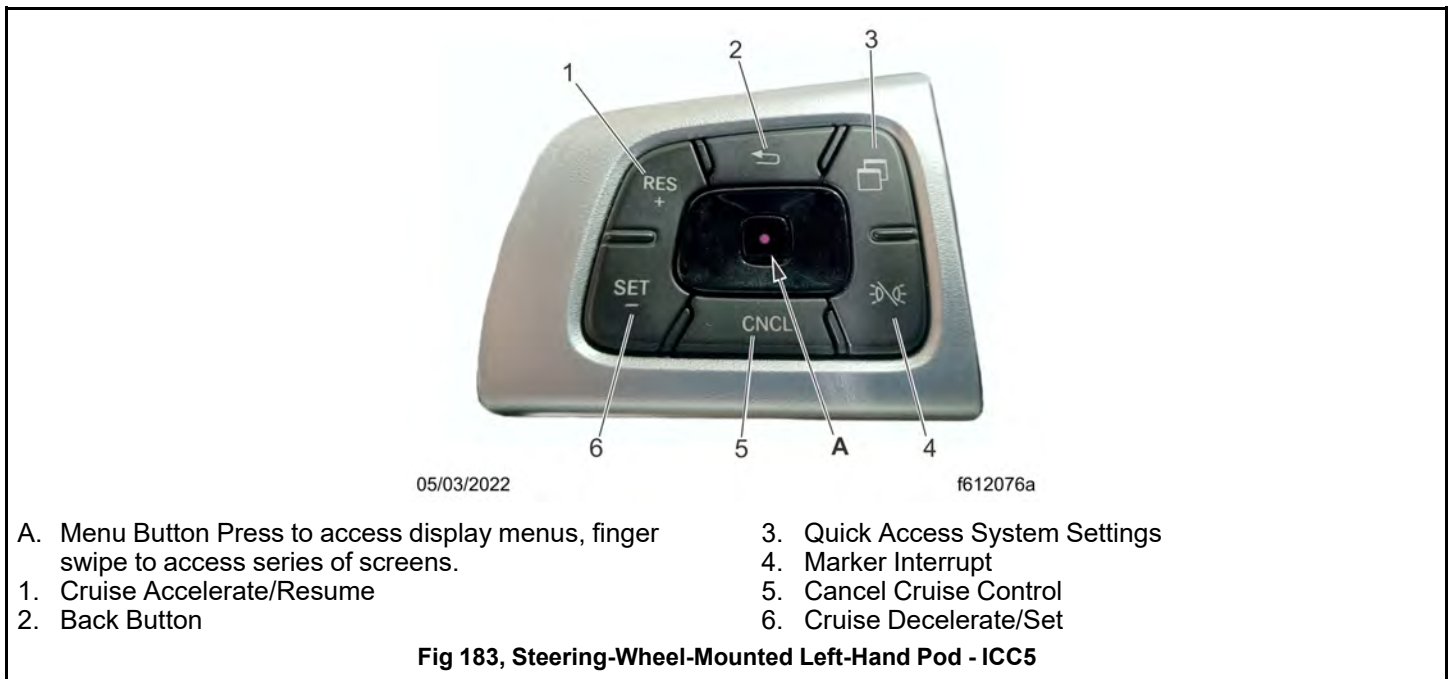
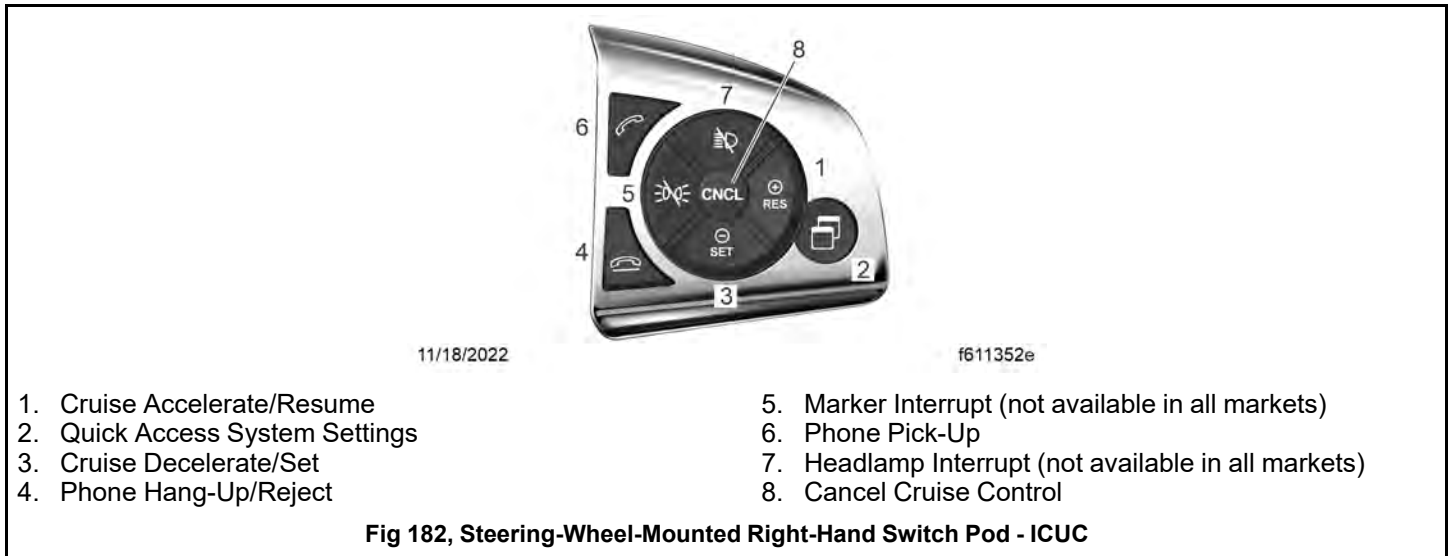

7.02 Detroit Assurance Vehicle Cameras

7.02.01 Multipurpose Camera 2 (MPC2)

IMPORTANT: The windshield must be clean, unobstructed, and without damage for the proper operation of the multipurpose camera and rain/light sensor.

The camera bracket that comes with Detroit Assurance 5.0 can hold a driver facing camera (DFC), multipurpose camera 2 (MPC2), and rain/light sensor (RLS). The unit is mounted against the windshield. See Fig. 184, [MPC2 Component Locations](#).

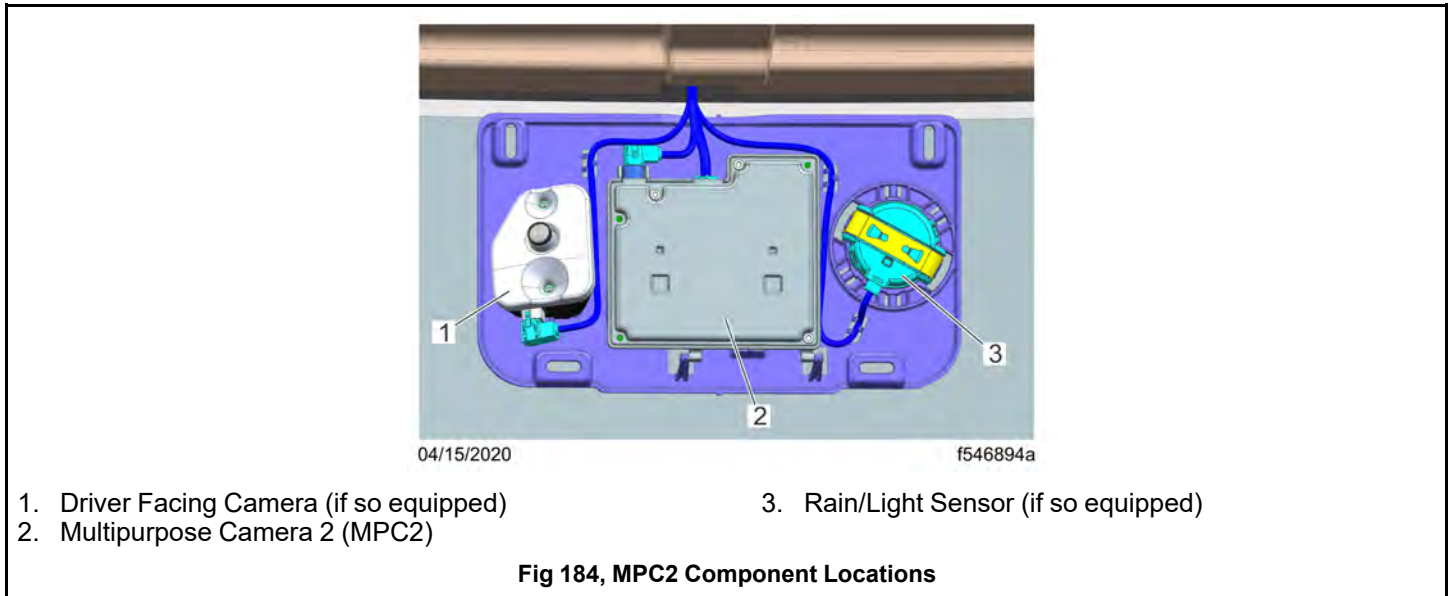

The MPC2 works with the radar system to support multiple Detroit Assurance features. It is important for the driver to keep the windshield clean and unobstructed in order for the MPC2 to operate properly.

7.02.02 Driver Facing Camera

IMPORTANT: The windshield must be clean, unobstructed, and without damage for the proper operation of the multipurpose camera and rain/light sensor.

The driver facing camera, if equipped, records the interior view in the case of a safety critical event.

7.02.03 Rain Light Sensor

IMPORTANT: The windshield must be clean, unobstructed, and without damage for the proper operation of the multipurpose camera and rain/light sensor.

This rain/light sensor, if equipped, detects rain, snow, or other precipitation on the windshield and can determine the amount of ambient light.

If the windshield wipers are set to intermittent operation, they automatically start clearing the windshield when the RLS detects precipitation. For additional windshield wiper and headlight information, see the topic in the **Driver Controls** chapter.

If the headlight switch is set to the automatic or 'A' position, the low beam headlights and vehicle exterior lights turn on when the RLS registers a low level of ambient light. This could happen due to sunset, fog, smoke, or any other event that decreases light levels.

7.02.04 Bendix Forward Facing Camera

IMPORTANT: The windshield must be clean, unobstructed, and without damage for the proper operation of the multipurpose camera and rain/light sensor.

IMPORTANT: In order for the forward facing camera to operate properly, the windshield area in front of the camera must be clean, unobstructed, and not be damaged in any way.

The Bendix forward-facing 5G camera is an available option that works in tandem with the Detroit Assurance MPC2 camera. If equipped, the Bendix camera appears as shown in Fig. 185, [MPC2 and Bendix Camera Brackets](#).

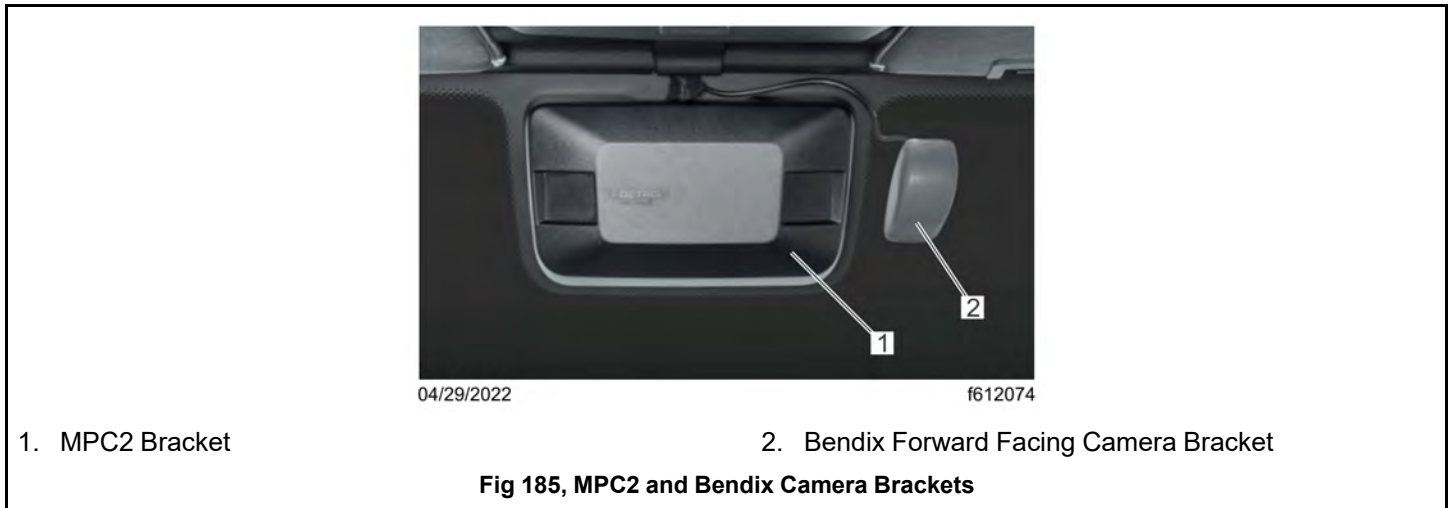

The Bendix camera records in color and can capture high-quality video in low-light conditions. For more information about the Bendix camera, see the **SafetyDirect® by Bendix** section in the **Driver Assistance Features** chapter.

7.03 Detroit Assurance Adaptive Cruise Control (ACC)

7.03.01 Adaptive Cruise Control Safety Information



WARNING:

The Detroit Assurance Collision Mitigation System is intended solely as an aid for an alert and conscientious professional driver. It is not intended to be relied upon to operate a vehicle. Use the system in conjunction with rearview mirrors and other instruments to safely operate the vehicle.

The Detroit Assurance Collision Mitigation System is not a substitute for safe, normal driving procedures, nor will it compensate for any driver impairment such as drugs, alcohol, fatigue, distraction or inattention.

Operate a vehicle equipped with Detroit Assurance Collision Mitigation System as if the vehicle were not equipped with a collision mitigation system.

Failure to drive safely and use the system properly could result in personal injury and/or death and severe property damage.

NOTE: In vehicles equipped with a DT12 transmission, this feature is called Adaptive Cruise Control to 0 mph. In instances where the feature capabilities are different, this will be called out. Otherwise, the feature will be called Adaptive Cruise Control (ACC).

ACC may not detect vehicles driving in a different lane or narrow vehicles, like motorcycles, driving in front.

In particular, stay aware in the following situations:

- when cornering, entering, and exiting bends;
- when driving winding stretches of road;
- when overtaking;
- when there are vehicles driving in a different lane;
- when vehicles are changing lanes;
- when vehicles are exiting the road;

- when there are obstacles and stationary vehicles.

ACC does not compensate for inattentive driving, weather, or traffic conditions. ACC is only an aid. The driver is responsible for maintaining a safe distance from the vehicle in front, maintaining a safe vehicle speed, braking, and remaining in a lane.

If ACC does not detect a vehicle driving in front, the system will accelerate to the set speed.

7.03.02 Adaptive Cruise Control Overview



WARNING:

The Detroit Assurance Collision Mitigation System is intended solely as an aid for an alert and conscientious professional driver. It is not intended to be relied upon to operate a vehicle. Use the system in conjunction with rearview mirrors and other instruments to safely operate the vehicle.

The Detroit Assurance Collision Mitigation System is not a substitute for safe, normal driving procedures, nor will it compensate for any driver impairment such as drugs, alcohol, fatigue, distraction or inattention.

Operate a vehicle equipped with Detroit Assurance Collision Mitigation System as if the vehicle were not equipped with a collision mitigation system.

Failure to drive safely and use the system properly could result in personal injury and/or death and severe property damage.

See Table 27, [Steering Wheel Controls](#) and Fig. 186, [Steering-Wheel-Mounted Right-Hand Switch Pod, ICUC](#) for a description of cruise control steering wheel switches.

| Description | Function |
|-------------|---|
| /SET | Sets the cruise speed while the vehicle is traveling at the desired speed. Pressing and holding decreases the set cruise speed. |
| + /RES | Resumes the set speed. Pressing and holding increases the set cruise speed. |
| CNCL | Deactivates cruise control, but retains the set speed in memory. |

Table 27, Steering Wheel Controls

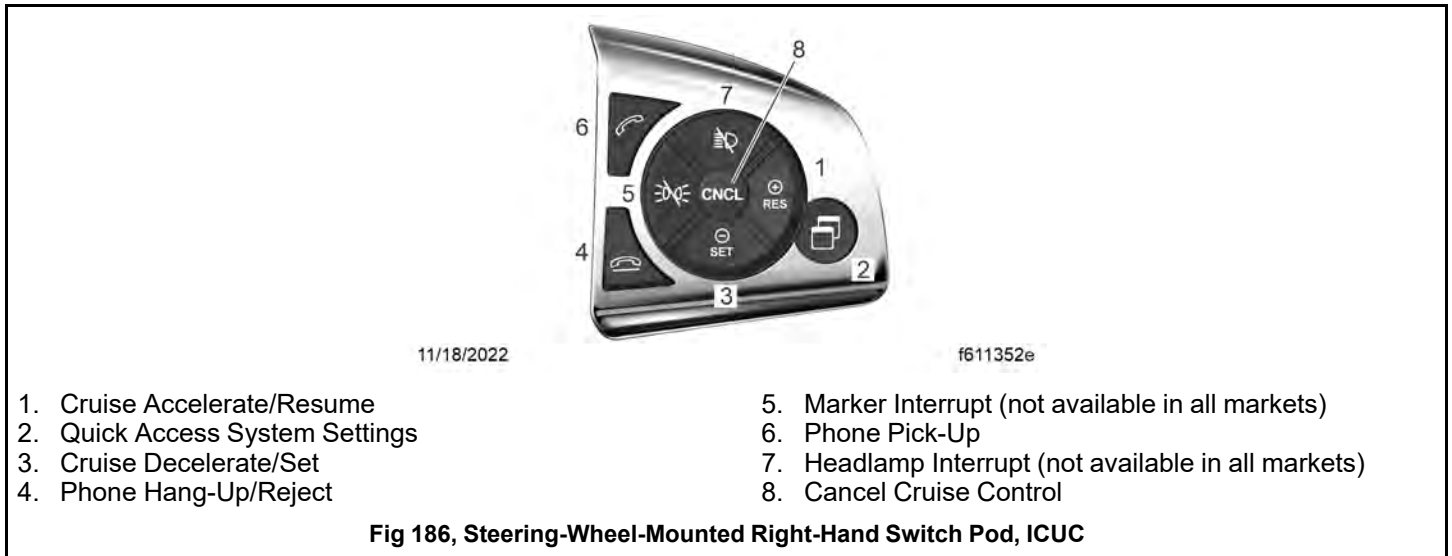

When a vehicle is detected in front, the driver display shows a generic image of the detected vehicle with the speed of and the distance to the detected vehicle at the top. An example of how this looks on the ICUC screen is shown in Fig. 187, [Adaptive Cruise Control \(ACC\) Screen - ICUC](#).



Adaptive Cruise Control Functions and Activation Conditions

Adaptive cruise control (ACC) controls the speed of the equipped vehicle to maintain a preset distance from a vehicle detected in front. It remains the driver's responsibility to ensure an appropriate distance is maintained.

If ACC detects a vehicle in front driving at a slower speed, the engine is defueled, the engine brakes are activated, and the service brakes are applied, slowing the vehicle to maintain the set following distance. The standard factory set following

distance is 3.6 seconds; for vehicles configured with adjustable headway, this can be adjusted under the 'Cruise Control' menu under 'Vehicle Settings.'

ACC allows the vehicle to operate in cruise all the way down to 0 mph (0km/h); as traffic in front of the vehicle slows and eventually stops, the vehicle will adjust with the traffic all the way to 0 mph (0km/h).

If the vehicle ahead is stopped for two seconds or less, ACC will resume when the vehicle ahead moves. If the vehicle ahead is stopped for more than two seconds, the driver after carefully checking surrounding traffic will need to press the resume button or tap the accelerator pedal to resume moving forward.

The ACC will also slow the vehicle if it exceeds the set speed (on a downhill grade, for example).

If there is no vehicle in front, ACC operates in the same way as cruise control when the vehicle is traveling above 10 mph (15 km/h).

IMPORTANT: Nothing should be put between the driver and the seat, such as a heating pad, massage pad, or similar items. Doing so may keep the seat occupancy sensor from functioning correctly. ACC to 0 mph verifies seat occupancy before resuming forward motion after slowing down to 0 mph.

ACC cannot be activated, or is automatically deactivated, if:

- the driver is not in their seat to activate the seat occupancy sensor;
- the vehicle is traveling slower than 10 mph (15 km/h);
- the transmission is in neutral for more than 5 seconds;
- reverse gear is selected;
- the Anti-Lock Braking System (ABS) is deactivated;
- there is a malfunction in the brake system or the electronic management system; or
- the distance sensor initialization is not yet complete.

Activating Adaptive Cruise Control and Setting the Speed

Activate ACC by setting the cruise speed, using the controls on the steering wheel. See Table 27, [Steering Wheel Controls](#).

When driving at the desired speed, press the /SET switch to activate ACC and store the set speed.

If cruise control is deactivated, the stored speed can be activated again by pressing the +/RES switch on the steering wheel switch pod. When activated, the driver display shows the adaptive cruise control telltale and the set speed.

If the brake pedal is pressed, ACC is deactivated automatically.

If ACC becomes unavailable, a message appears on the driver display screen. If the vehicle is programmed to allow for standard cruise control, the message displayed allows the driver to use standard cruise control. See Fig. 188, [Adaptive Cruise Control \(ACC\) Unavailable - ICUC](#).



Increasing or Reducing Adaptive Cruise Control Speed

The ACC speed setting can only be set when driving.

Press the /SET switch on the steering wheel switch pod to set the cruise speed when the vehicle is traveling at the desired speed. To decrease the set cruise speed, press and hold /SET.

Setting the Adaptive Cruise Control Distance to the Vehicle in Front

If equipped, the ACC ICUC menu under 'Settings' > 'Safety Systems Settings' > 'More Information' > 'Adaptive Cruise Control' can be used to set the overspeed and underspeed limits and the following distance to the vehicle in front.

If equipped, the ACC ICC5 following distance can be adjusted under 'Settings' > 'Driving Assistance' > 'Adaptive Cruise Control.'

IMPORTANT: Make sure that the minimum distance required by law is maintained.

Overtaking When Using Adaptive Cruise Control

NOTE: It is possible to exceed the set speed when overtaking.

The set speed of ACC can be exceeded using the accelerator pedal. When the accelerator pedal is released, the ACC set speed will be resumed.

Deactivating Adaptive Cruise Control

To deactivate ACC, press the CNCL switch on the steering wheel switch pod or press the brake pedal.

NOTE: The set speed remains stored when ACC is deactivated.

7.04 Detroit Assurance Tailgate Warning

The tailgate warning provides alerts when the vehicle in front is being followed too closely.

The system gives warning when:

- ACC is not active;
- the vehicle is moving faster than 20 mph (32 km/h);
- the driver follows a vehicle for longer than 10 seconds at a distance that will be traversed in less than 2.6 seconds.

The system will also give warnings when ACC is active, if:

- the driver is overriding the distance control by pressing on the accelerator pedal;
- the vehicle is moving faster than 20 mph (32 km/h);
- the driver follows a vehicle for longer than 10 seconds at a distance that will be traversed in less than 2.6 seconds.

The system will continue to give warning every 20 seconds if the gap between the vehicles does not increase.

The system will **not** give warning when:

- the vehicle is moving slower than 20 mph (32 km/h);
- another vehicle cuts in front;
- the vehicle in front is moving away;
- ACC distance control is active.

7.05 Detroit Assurance Active Brake Assist 5 (ABA5)

7.05.01 Active Brake Assist 5 Overview

IMPORTANT: The windshield must be clean, unobstructed, and without damage for proper operation of the multipurpose camera. No objects or attachments should be mounted in front of the forward radar and the radar covering should be free of paint, stickers, mud, ice, or snow.

ABA is active when the vehicle is on.

ABA uses fused camera and radar signals for improved object recognition, enabling it, in some cases, to recognize potential hazardous situations faster than a driver. If the camera cannot positively identify an object, radar signals alone are used. If the camera becomes unplugged or otherwise disabled, ABA is disabled.

ABA tracks both moving and stationary objects in the vehicle's path and, if necessary, engages in a cascade of defensive actions in reaction to those objects through:

1. visual and auditory warnings;
2. then partial braking;
3. then full or emergency braking.

In addition to moving and braking vehicles, ABA has the capacity to recognize and engage in emergency braking for moving pedestrians, parked vehicles, and stopped traffic.

However, the system may not detect pedestrians or objects in every situation. ABA is not a substitute for cautious driving.

7.05.02 Active Brake Assist 5 Safety Information



WARNING:

Active Brake Assist (ABA) is intended only as an aid for a conscientious and alert driver. The driver is responsible for keeping a safe distance from the vehicle in front, for the vehicle speed, braking in a sufficient amount of time, and remaining in the lane.

ABA does not take road and weather conditions into account, nor the prevailing traffic situation. The driver should always adapt their driving to suit road and weather conditions.

The Detroit Assurance Collision Mitigation System is not designed to warn about all possible road hazards. Specifically, it is not programmed to react to animals, oncoming vehicles, or cross traffic, but it may do so.

Operate a vehicle equipped with Detroit Assurance Collision Mitigation System as if the vehicle were not equipped with a collision mitigation system.

Failure to drive safely and use the system properly could result in personal injury and/or death and severe property damage.

A vehicle equipped with ABA may:

- react more quickly than a driver to an object in the vehicle's path of travel;

- perform emergency braking;
- react to moving people with a warning and emergency braking.

ABA can minimize the risk of a front-end collision with a moving or stationary vehicle and pedestrians. If ABA detects the risk of a front-end collision, it issues an audible and visual warning. If the risk persists, ABA automatically initiates partial braking of the vehicle. If the driver does not react to the warnings and partial brake application, ABA automatically initiates a full emergency brake application.

ABA is not designed to detect and react to vehicles driving in a different lane.

ABA may not react to narrow vehicles, like motorcycles, driving in front of the vehicle.

A driver should always be aware of possible hazards and be prepared to engage the service brakes if the ABA system warns of a possible pending collision.

ABA does not automatically adapt to road and traffic conditions. If ABA issues no visual and/or acoustic warning in a critical situation:

- it is suppressed;
- it has failed;
- it has not recognized the danger of the situation.

ABA may also issue warnings where no risk exists. An alert and conscientious driver should be able to easily validate an ABA warning, and, if necessary, override a false-positive ABA braking event.

7.05.03 Activating and Deactivating Active Brake Assist 5

To override the ABA warning and braking sequence, press the accelerator pedal past the pressure point to engage kickdown.

If there is a system error, the ABA unavailable telltale, as shown in Fig.189, [ABA Unavailable Warning](#), illuminates on the driver display screen and a caution window, as shown in Fig.190, [ABA Unavailable Alert - ICUC](#), is shown on the driver display.



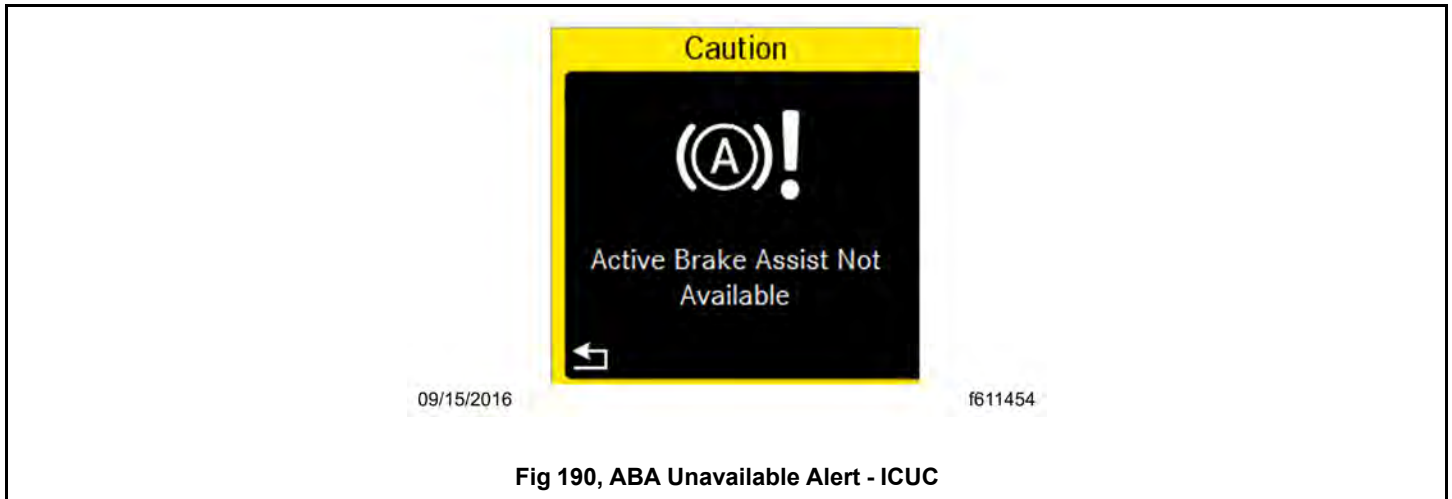

Fig 190, ABA Unavailable Alert - ICUC

7.05.04 Active Brake Assist 5 Collision Warning and Emergency Braking

NOTE: A driver can override ABA if, during an ABA braking event, the driver presses the accelerator pedal beyond the pressure point to engage kickdown.

If there is a collision risk, ABA engages in the following cascade of warnings:

1. **Issues Warnings:** the radio and/or hands free system is muted, the vehicle issues a warning beeping, and an ABA collision warning window, shown in Fig.191, [First Visual ABA Warning - ICUC](#), appears on the driver display.

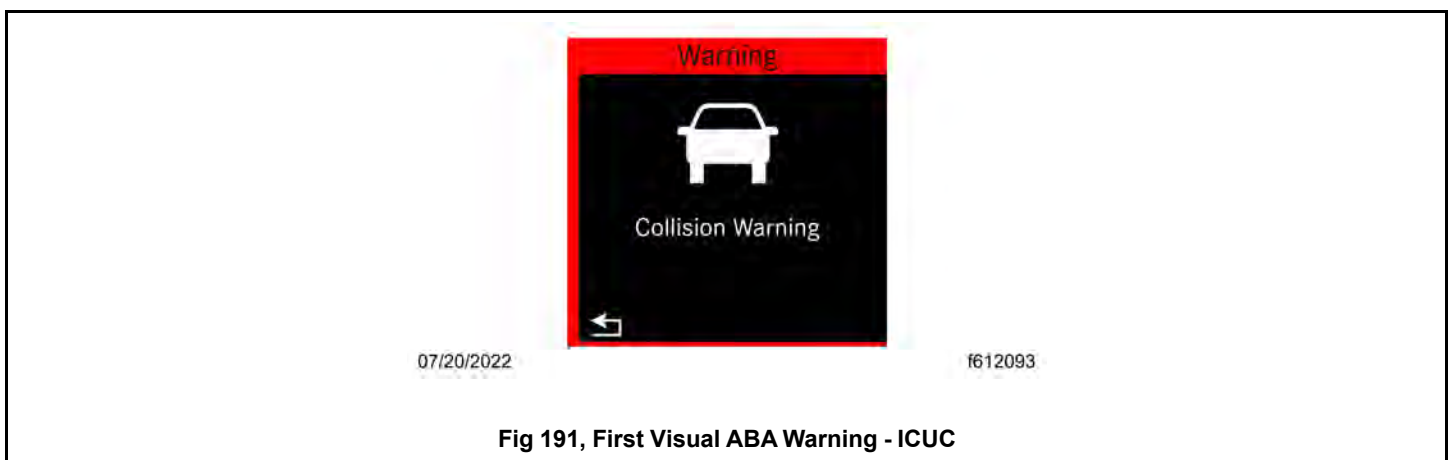

Fig 191, First Visual ABA Warning - ICUC

2. **Engages in Partial Braking:** ABA brakes the vehicle with around 50 percent of the vehicle's maximum braking power. The radio and/or hands free system stays muted, the warning beeping continues, and the ABA collision warning, shown in Fig.191, [First Visual ABA Warning - ICUC](#), continues to appear or, if previously dismissed, reappears on the driver display.
3. **Engages in Emergency Braking:** If a driver does not react to the collision warnings or partial brake application, ABA brakes the vehicle with 100 percent of the vehicle's maximum braking power. The radio and/or hands free system stays muted, the warning beeping shifts to a continuous tone, and the emergency braking warning, shown in Fig.192, [Second Visual ABA Warning - ICUC](#) appears on the driver display.

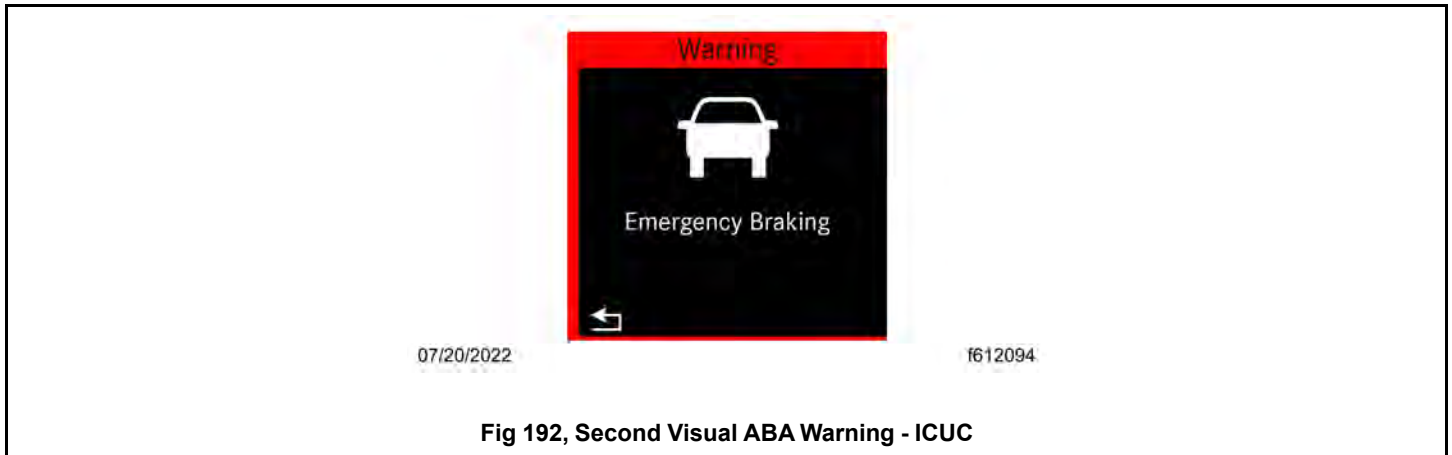

Fig 192, Second Visual ABA Warning - ICUC

4. **Brakes Release:** The radio and/or hands free system is taken off mute, the warning tone ceases, and the notice shown in Fig.193, [Third Visual Warning in ABA Cascade](#) appears on the driver display.

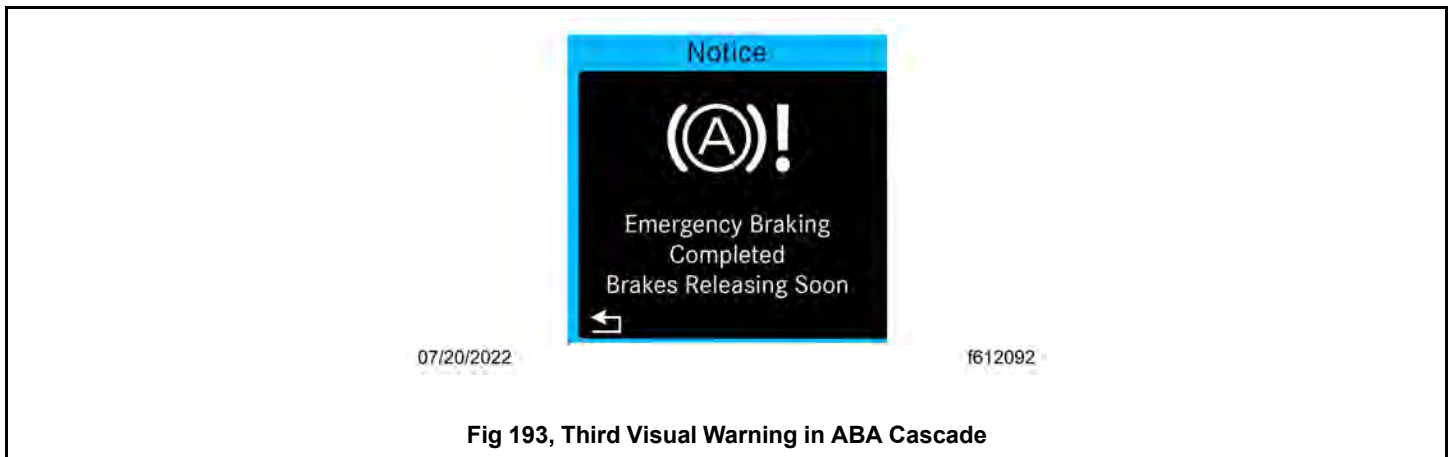

Fig 193, Third Visual Warning in ABA Cascade

After retaking control, the driver should take the first opportunity to safely move the vehicle from traffic. Before continuing, the driver should confirm that the vehicle is in good operating condition and that the load is still properly secured.



CAUTION:

After an emergency braking maneuver has been performed, retake control of the vehicle and, if necessary, move the vehicle from the area of danger.

Take the first opportunity to safely move the vehicle from traffic to confirm the load is still properly secured and that the vehicle is still in good operating order. Failure to do so may result in personal injury and product or property damage

Always apply the parking brake prior to exiting the vehicle.

7.05.05 Overriding ABA Events

If ABA sets off an audio and/or haptic warning where the driver determines that no risk exists or the critical situation has resolved, an alert and conscientious driver may override the ABA braking event.

To override the ABA alert, fully depress the throttle to the floor. If you are already at full throttle, release the throttle and fully depress again to cancel the warning cascade.

7.06 Limitations of Detroit Assurance ABA5 and ACC

See Table 28, [Adaptive Cruise Control and Active Brake Assist 5 Limitations](#) for a description of ABA5 and ACC limitations in specific driving conditions.

| Condition and Illustration | Description |
|--|--|
| <p style="text-align: center;">Cornering, entering and exiting bends</p>  <p>07/27/2022 f040877</p> | <p>The ability of ABA5 and ACC to react to vehicles on bends is limited.</p> <p>ABA5 and ACC may react to a vehicle or object in an adjoining lane and unexpectedly issue warnings or brake the vehicle.</p> <p>ABA5 and ACC may be slow to react to a vehicle or object previously hidden by a bend in the lane.</p> <p>ACC may also accelerate the vehicle unexpectedly if the vehicle ahead is hidden by a bend in the lane.</p> |
| <p style="text-align: center;">Vehicles not traveling in line with your vehicle and stationary vehicles</p>  <p>07/27/2022 f040883</p> | <p>The ability of ABA5 and ACC to react to vehicles not traveling in line with your vehicle and stationary vehicles is limited.</p> <p>ABA5 and ACC may react to a vehicle or object partially in your lane and unexpectedly issue warnings or brake your vehicle.</p> <p>ABA5 and ACC may be slow or fail to react to vehicles not traveling in line with your vehicle or stationary vehicles only partially in your lane.</p> <p>ACC may not detect and react to vehicles not traveling in line with your vehicle or stationary vehicles partially in your lane and may accelerate unexpectedly.</p> |
| <p style="text-align: center;">Other vehicles changing lanes</p>  <p>07/27/2022 f040884</p> | <p>The ability of ABA5 and ACC to detect and react to vehicles pulling into your lane without maintaining a safe distance is limited.</p> <p>ABA5 and ACC may be slow to react or fail to react to a vehicle entering your lane if the distance to the vehicle entering the lane is too short.</p> <p>ACC may accelerate unexpectedly if it fails to detect the vehicle entering the lane.</p> <p>If a vehicle cuts in front, brake your vehicle to increase the following distance.</p> |
| <p style="text-align: center;">Narrow vehicles changing lanes</p> | <p>The ability of ABA5 and ACC to detect and react to narrow vehicles pulling into your lane is limited.</p> |

Table 28, Adaptive Cruise Control and Active Brake Assist 5 Limitations

| Condition and Illustration | Description |
|--|--|
|  <p>07/27/2022 f040876</p> | <p>Narrow vehicles may be slow to enter the system's detection range.</p> <p>ABA5 and ACC may be slow to react or fail to react to a critical driving situation due to the merging vehicle being slow to enter the system's detection range.</p> <p>ACC may accelerate unexpectedly if it fails to detect the vehicle entering the lane.</p> |
| <p>Vehicles turning off or in a nonstandard orientation.</p>  <p>07/27/2022 f040885</p> | <p>The ability of ABA5 and ACC to detect and react to vehicles turning off or vehicles in a nonstandard orientation is limited.</p> <p>ABA5 and ACC may react to a vehicle turning off and unexpectedly issue warnings or brake the vehicle.</p> <p>ABA5 and ACC may be slow or fail to react to a vehicle turning off or to a vehicle at an angle due to an accident even through there is a critical driving situation.</p> |
| <p>Overtaking</p>  <p>07/27/2022 f040879</p> | <p>The ability of ABA5 and ACC to detect and react to a vehicle you are overtaking is limited.</p> <p>When overtaking a vehicle, ABA5 and ACC may unexpectedly issue warnings or brake your vehicle if you drive too close to the vehicle you are overtaking before exiting that lane.</p> |
| <p>Winding stretches of road</p> | <p>On winding stretches of road, ABA5 and ACC cannot detect which lane the vehicle in front is driving in.</p> <p>ABA5 and ACC may unexpectedly issue warnings or brake your vehicle when reacting to vehicles in a different lane.</p> <p>ABA5 and ACC may be slow to react or fail to react to a vehicle in your lane even through there is a critical driving situation.</p> <p>ACC may fail to detect the vehicle in front in your lane and may accelerate the vehicle unexpectedly.</p> |

Table 28, Adaptive Cruise Control and Active Brake Assist 5 Limitations

| Condition and Illustration | Description |
|---|--|
|  <p>07/27/2022 f040886</p> | |
| <p>Obstacles and stationary vehicles in front of a detected vehicle</p>  <p>07/27/2022 f040878</p> | <p>The ability of ABA5 and ACC to detect and react to objects when the detected vehicle turns off is limited.</p> <p>When the detected vehicle turns off, ABA5 and ACC may react to the obstacle or stationary vehicle that was in front of the detected vehicle and unexpectedly issue warnings or brake your vehicle.</p> <p>When the detected vehicle turns off, ABA5 and ACC may be slow to react or fail to react to an obstacle or stationary vehicle that was in front of the detected vehicle even though there is a critical driving situation.</p> <p>ACC may react to the vehicle turning off by accelerating unexpectedly.</p> |
| <p>Vehicles parked or broken down at the side of the road</p>  <p>07/27/2022 f040880</p> | <p>The ability of ABA5 and ACC to detect and react to a stationary vehicle on the side of the road is limited.</p> <p>ABA5 and ACC may unexpectedly issue warnings or brake your vehicle if it detects a vehicle on the side of the road.</p> |

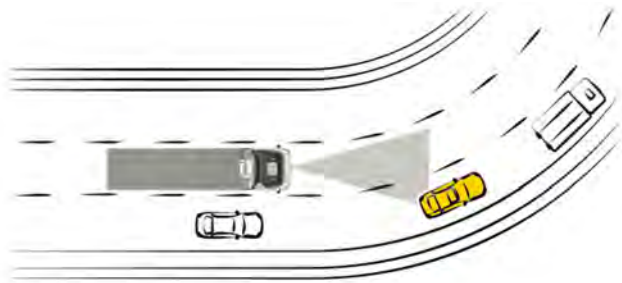
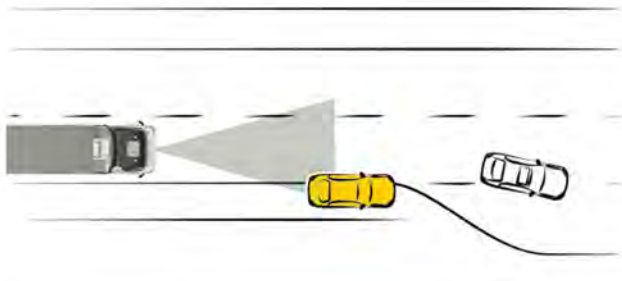
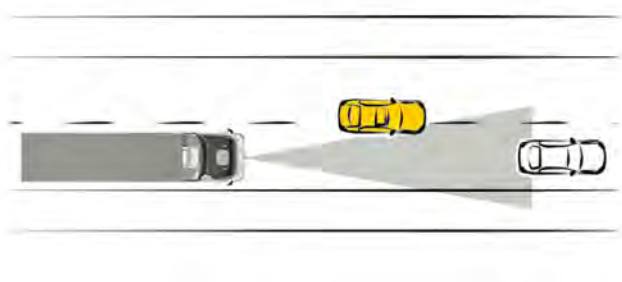
Table 28, Adaptive Cruise Control and Active Brake Assist 5 Limitations

| Condition and Illustration | Description |
|---|---|
| <p style="text-align: center;">Stationary objects</p>  <p>07/27/2022 f040882</p> | <p>The ability of ABA5 and ACC to detect and react to stationary objects above, beside, and on the road is limited.</p> <p>ABA5 and ACC can unexpectedly issue warnings and brake the vehicle if it detects stationary objects beside, above, or in front of your lane such as:</p> <ul style="list-style-type: none"> • signs • traffic islands • some bridges, such as truss and cable bridges • low overpasses |
| <p style="text-align: center;">People</p>  <p>07/27/2022 f040881</p> | <p>The ability of ABA5 to detect and react to people in certain situations is limited.</p> <p>ABA5 can unexpectedly issue warnings and brake the vehicle if it detects and reacts to:</p> <ul style="list-style-type: none"> • people on the roadside on a curve • people walking beside the road • people in a tunnel |

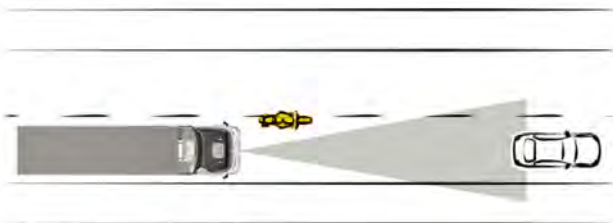
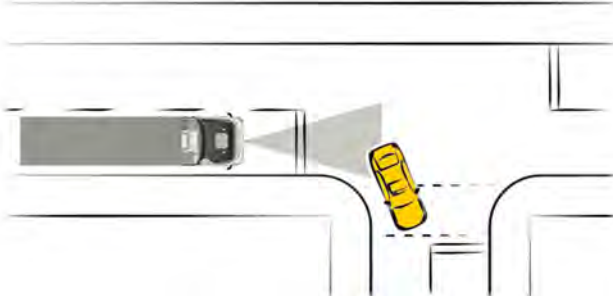
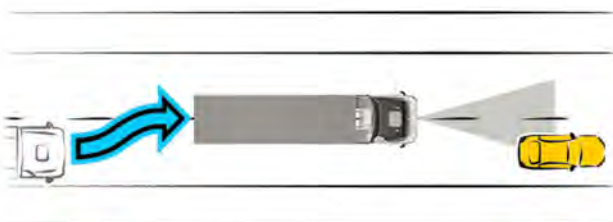
7.07 Detroit Assurance Lane Departure Warning (LDW)

7.07.01 Lane Departure Warning Safety Information

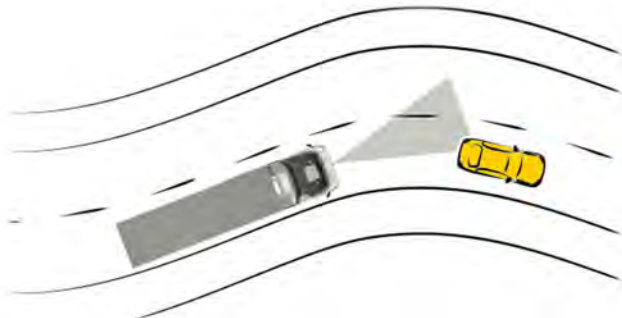
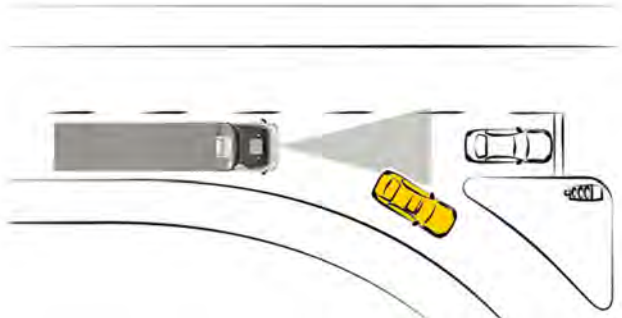
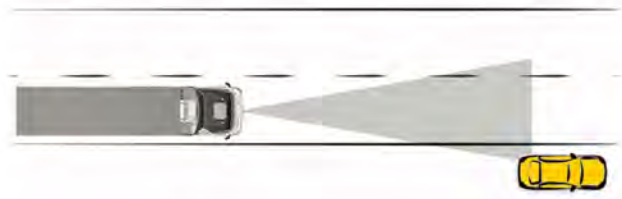
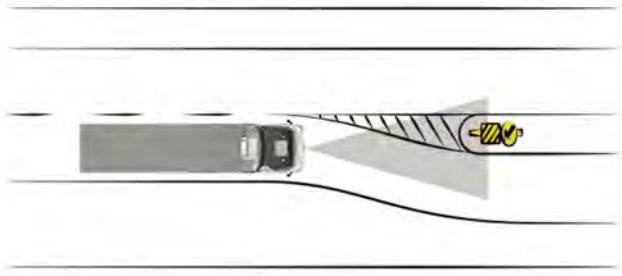
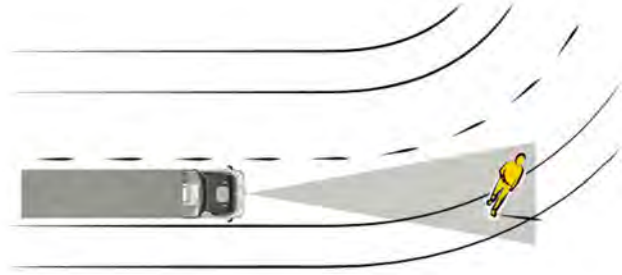

WARNING:

The LDW system is intended only as an aid for a conscientious and alert driver. Do not rely solely on the system to safely operate the vehicle.

The system may not indicate lane departures under certain conditions. Read the information in this manual to understand the circumstances under which this system may not provide adequate lane departure warnings.

The system does not provide warnings for all possible hazards. LDW is not a substitute for safe driving procedures and cannot prevent an accident if the driver is impaired or not driving safely.

Failure to use the system properly could result in personal injury and/or death and severe property damage.

**WARNING:**

The Detroit Assurance Collision Mitigation System is intended solely as an aid for an alert and conscientious professional driver. It is not intended to be relied upon to operate a vehicle. Use the system in conjunction with rearview mirrors and other instruments to safely operate the vehicle.

The Detroit Assurance Collision Mitigation System is not a substitute for safe, normal driving procedures, nor will it compensate for any driver impairment such as drugs, alcohol, fatigue, distraction or inattention.

Operate a vehicle equipped with Detroit Assurance Collision Mitigation System as if the vehicle were not equipped with a collision mitigation system.

Failure to drive safely and use the system properly could result in personal injury and/or death and severe property damage.

The system may be impaired or may not operate in the following situations:

- There is low visibility due to insufficient road illumination, or due to snow, rain, fog, heavy spray, smoke, or other circumstances that limit visibility.
- There is glare due to oncoming traffic, direct sunlight, or reflections from wet road surfaces.
- The windshield around the camera is dirty, misted up, damaged, or covered by a sticker.
- No lane markings or several varied lane markings are present, such as in a construction zone.
- The lane markings are worn, dark, or covered such as by sand, dirt, or snow.
- The distance from the vehicle in front is too small and prevents the lane markings from being detected.
- The lane markings change rapidly, such as when lanes merge, branch off, or cross.
- Lanes are very narrow or winding.
- Shade conditions on the road surface vary widely.
- an attachment (such as a snow plow) restricting the camera's view of the lane markings;
- a significant change in load with the vehicle on. Start the vehicle after a significant change in load to have LDW available without restrictions.

The driver must adapt their driving style to current conditions. LDW cannot take the road and weather conditions into account, nor the prevailing traffic situation. The driver is responsible for the distance to the vehicle in front, for vehicle speed, braking in good time, and remaining in the lane.

7.07.02 Lane Departure Warning Overview

**WARNING:**

The LDW system is intended only as an aid for a conscientious and alert driver. Do not rely solely on the system to safely operate the vehicle.

The system may not indicate lane departures under certain conditions. Read the information in this manual to understand the circumstances under which this system may not provide adequate lane departure warnings.

The system does not provide warnings for all possible hazards. LDW is not a substitute for safe driving procedures and cannot prevent an accident if the driver is impaired or not driving safely.

Failure to use the system properly could result in personal injury and/or death and severe property damage.

**WARNING:**

The Detroit Assurance Collision Mitigation System is intended solely as an aid for an alert and conscientious professional driver. It is not intended to be relied upon to operate a vehicle. Use the system in conjunction with rearview mirrors and other instruments to safely operate the vehicle.

The Detroit Assurance Collision Mitigation System is not a substitute for safe, normal driving procedures, nor will it compensate for any driver impairment such as drugs, alcohol, fatigue, distraction or inattention.

Operate a vehicle equipped with Detroit Assurance Collision Mitigation System as if the vehicle were not equipped with a collision mitigation system.

Failure to drive safely and use the system properly could result in personal injury and/or death and severe property damage.

LDW monitors the area in front of the vehicle using the multipurpose camera mounted at the top of the windshield. When LDW is active and detecting lane markings, it visually and audibly warns the driver if it thinks the vehicle may be leaving the lane unintentionally.

LDW only needs one identifiable lane line to function.

7.07.03 Functions and Activation Conditions for Lane Departure Warning

**WARNING:**

The LDW system is intended only as an aid for a conscientious and alert driver. Do not rely solely on the system to safely operate the vehicle.

The system may not indicate lane departures under certain conditions. Read the information in this manual to understand the circumstances under which this system may not provide adequate lane departure warnings.

The system does not provide warnings for all possible hazards. LDW is not a substitute for safe driving procedures and cannot prevent an accident if the driver is impaired or not driving safely.

Failure to use the system properly could result in personal injury and/or death and severe property damage.

**WARNING:**

The Detroit Assurance Collision Mitigation System is intended solely as an aid for an alert and conscientious professional driver. It is not intended to be relied upon to operate a vehicle. Use the system in conjunction with rearview mirrors and other instruments to safely operate the vehicle.

The Detroit Assurance Collision Mitigation System is not a substitute for safe, normal driving procedures, nor will it compensate for any driver impairment such as drugs, alcohol, fatigue, distraction or inattention.

Operate a vehicle equipped with Detroit Assurance Collision Mitigation System as if the vehicle were not equipped with a collision mitigation system.

Failure to drive safely and use the system properly could result in personal injury and/or death and severe property damage.

The Detroit Assurance LDW system is designed to warn the driver as the vehicle crosses the outer boundary of the lane marking. This may differ from other LDW systems which issue a warning as the driver approaches the inside of the lane marking. If the system warns at, or just beyond the outer edge of the lane marking, the system is performing as designed. If the warning does not occur, or occurs after an excessive lane departure, the system may not be operating properly or the situation is outside of activation parameters.

Lane departure warning only issues warnings if the speed is above approximately 37 mph (60 km/h).

The lane markings on the driver display screen show the status and state of LDW:

- No lane markings indicate that LDW is off.
- Outlined lane markings indicate that LDW is not ready.
- Solid white markings indicate LDW is on and ready to issue warnings.
- Red lane markings indicate a lane departure is occurring; red lane markings are a visual warning from the LDW system.

In addition to the visual warning, when driving over lane markings unintentionally, the volume of audio equipment like the radio and/or hands-free systems is muted and a "rumble-strip noise" emits from the side of the vehicle driving over the lane markings.

LDW does not issue an audible warning when:

- the turn signals are switched on
- if the driver is braking or accelerating
- if the driver is making a sharp turn
- if a driving safety system such as ABA, stability control, or ACC intervenes.

7.07.04 Activating or Deactivating Lane Departure Warning (LDW)

**WARNING:**

The LDW system is intended only as an aid for a conscientious and alert driver. Do not rely solely on the system to safely operate the vehicle.

The system may not indicate lane departures under certain conditions. Read the information in this manual to understand the circumstances under which this system may not provide adequate lane departure warnings.

The system does not provide warnings for all possible hazards. LDW is not a substitute for safe driving procedures and cannot prevent an accident if the driver is impaired or not driving safely.

Failure to use the system properly could result in personal injury and/or death and severe property damage.

When the engine is turned on, LDW is automatically activated.

NOTE: There is no audible self-test of the "rumble-strip noise" of LDW when the key is turned on.

Pressing the LDW OFF switch deactivates LDW for fifteen minutes. The LDW OFF switch may be a physical dash switch, shown in Fig.194, [Lane Departure Warning Off Physical Switch](#), and/or a digital switch in the ICC5 infotainment panel under 'Digital Switches,' shown in Fig.195, [Lane Departure Warning Off Digital Switch, ICC5](#). When LDW is deactivated, the switch indicator illuminates.

A driver might want to turn off LDW on winding roads or when driving through construction zones or other areas where lane markings are not clear.

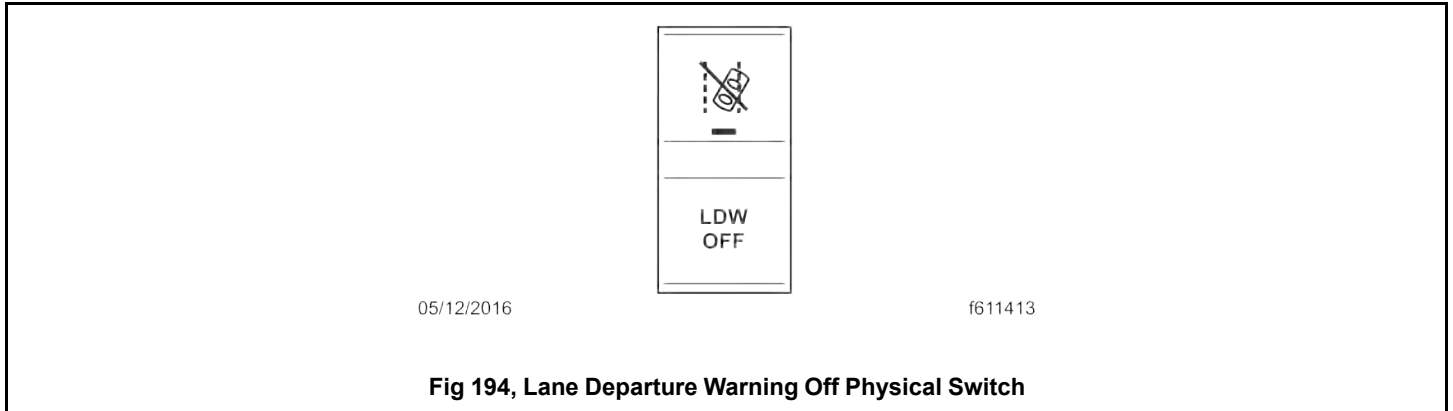

NOTE: Vehicles equipped with Detroit Assurance and an MPC2 camera, but no LDW system may have a permanently illuminated LDW OFF switch as LDW has been disabled.

LDW is not active if:

- the driver presses the LDW OFF switch;
- the system is searching for a lane.

If there is a system error, the LDW unavailable telltale, shown in Fig.196, [LDW Unavailable Telltale](#), illuminates on the driver display.



7.07.05 Cleaning the Windshield in the Area of the Camera

**WARNING:**

The LDW system is intended only as an aid for a conscientious and alert driver. Do not rely solely on the system to safely operate the vehicle.

The system may not indicate lane departures under certain conditions. Read the information in this manual to understand the circumstances under which this system may not provide adequate lane departure warnings.

The system does not provide warnings for all possible hazards. LDW is not a substitute for safe driving procedures and cannot prevent an accident if the driver is impaired or not driving safely.

Failure to use the system properly could result in personal injury and/or death and severe property damage.

**WARNING:**

The Detroit Assurance Collision Mitigation System is intended solely as an aid for an alert and conscientious professional driver. It is not intended to be relied upon to operate a vehicle. Use the system in conjunction with rearview mirrors and other instruments to safely operate the vehicle.

The Detroit Assurance Collision Mitigation System is not a substitute for safe, normal driving procedures, nor will it compensate for any driver impairment such as drugs, alcohol, fatigue, distraction or inattention.

Operate a vehicle equipped with Detroit Assurance Collision Mitigation System as if the vehicle were not equipped with a collision mitigation system.

Failure to drive safely and use the system properly could result in personal injury and/or death and severe property damage.

Make sure that the windshield is always kept clean and unobstructed around the camera.

During rainy or cold weather, the driver should switch on the windshield wiper to clear the windshield and remove snow and ice to avoid incorrect lane detection.

If the area of the windshield is damaged, LDW may not work as intended. If this happens, the windshield must be replaced.

7.08 Detroit Assurance Active Lane Assist (ALA)

7.08.01 Active Lane Assist Safety Information

**WARNING:**

The features in active lane assist (ALA) are intended only as aids for a conscientious and alert driver. Do not rely on ALA to safely operate the vehicle.

The driver is responsible for keeping their hands on the wheel at all times when ALA is active.

ALA may not indicate lane departures under certain conditions. Read the information in this manual to understand the circumstances under which ALA may not provide adequate lane departure warnings.

ALA does not warn of all possible hazards and is not a substitute for safe driving procedures.

Failure to drive safely and use ALA properly could result in personal injury and/or death and severe property damage.

**WARNING:**

The Detroit Assurance Collision Mitigation System is intended solely as an aid for an alert and conscientious professional driver. It is not intended to be relied upon to operate a vehicle. Use the system in conjunction with rearview mirrors and other instruments to safely operate the vehicle.

The Detroit Assurance Collision Mitigation System is not a substitute for safe, normal driving procedures, nor will it compensate for any driver impairment such as drugs, alcohol, fatigue, distraction or inattention.

Operate a vehicle equipped with Detroit Assurance Collision Mitigation System as if the vehicle were not equipped with a collision mitigation system.

Failure to drive safely and use the system properly could result in personal injury and/or death and severe property damage.

Features in ALA may become inactive under conditions where lane markings cannot clearly be identified. These conditions include:

- low visibility, due to insufficient road illumination or due to snow, rain, fog, smoke, or heavy spray;
- glare from oncoming traffic, the sun, or reflection from other vehicles when the road surface is wet;
- the windshield being dirty, misted up, damaged, or covered in the vicinity of the camera;
- the lane markings being unclear, such as in a construction zone;
- the lane markings being worn, dark, or covered;
- the distance to the vehicle in front being too small and preventing the lane markings from being detected;
- the lane markings changing quickly lanes branching off, crossing one another, or merging;
- the road being narrow and winding;
- highly variable shade conditions on the road surface;
- an attachment (such as a snow plow) restricting the camera's view of the lane markings;
- a significant change in load with the vehicle on. Start the vehicle after a significant change in load to have ALA available without restrictions.

ALA cannot take the road, weather conditions, or the current traffic situation into account. The driver is responsible for maintaining a safe distance to the vehicle in front, for vehicle speed, braking in good time, and remaining in the lane.

7.08.02 Active Lane Assist Overview

**WARNING:**

The features in active lane assist (ALA) are intended only as aids for a conscientious and alert driver. Do not rely on ALA to safely operate the vehicle.

The driver is responsible for keeping their hands on the wheel at all times when ALA is active.

ALA may not indicate lane departures under certain conditions. Read the information in this manual to understand the circumstances under which ALA may not provide adequate lane departure warnings.

ALA does not warn of all possible hazards and is not a substitute for safe driving procedures.

Failure to drive safely and use ALA properly could result in personal injury and/or death and severe property damage.

IMPORTANT: ACC must be active for LKA to be active. Deactivation of ACC also deactivates LKA.

NOTE: Earlier versions of ALA may not be equipped with the auto stop feature.

ALA with auto stop consists of:

- lane departure protection (LDP), a feature that builds on LDW
- lane keep assist (LKA)
- auto stop, a feature that builds on LKA

When ALA with auto stop is on, it monitors the area in front of the vehicle with the multipurpose camera mounted at the top of the windshield. Keep the windshield clean and unobstructed in the area of the camera.

The LDW/LDP function of ALA detects lane markings on the road surface, warns the driver they may be leaving their lane unintentionally, and, if a driver does not respond to these warnings, moves the vehicle back into the center of the lane. If the driver's preferred lane position is other than 'center,' LKA will move the vehicle into the requested lane position after the LDP intervention is complete.

The LKA function of ALA uses micro-steering adjustments to keep the vehicle in the driver's preferred lane position. It also monitors the driver's steering, and if it senses the driver's hands have been removed, cautions the driver to return their hands to the steering wheel.

Auto stop works with LKA to smoothly bring the vehicle to a safe stop after LKA has registered that the driver has had their hands off the steering wheel for 60 seconds. Auto stop works to increase the safety of all road users in the case of an incapacitated driver.

7.08.03 Active Lane Assist Activation Conditions



WARNING:

The features in active lane assist (ALA) are intended only as aids for a conscientious and alert driver. Do not rely on ALA to safely operate the vehicle.

The driver is responsible for keeping their hands on the wheel at all times when ALA is active.

ALA may not indicate lane departures under certain conditions. Read the information in this manual to understand the circumstances under which ALA may not provide adequate lane departure warnings.

ALA does not warn of all possible hazards and is not a substitute for safe driving procedures.

Failure to drive safely and use ALA properly could result in personal injury and/or death and severe property damage.



WARNING:

The Detroit Assurance Collision Mitigation System is intended solely as an aid for an alert and conscientious professional driver. It is not intended to be relied upon to operate a vehicle. Use the system in conjunction with rearview mirrors and other instruments to safely operate the vehicle.

The Detroit Assurance Collision Mitigation System is not a substitute for safe, normal driving procedures, nor will it compensate for any driver impairment such as drugs, alcohol, fatigue, distraction or inattention.

Operate a vehicle equipped with Detroit Assurance Collision Mitigation System as if the vehicle were not equipped with a collision mitigation system.

Failure to drive safely and use the system properly could result in personal injury and/or death and severe property damage.

ALA is activated each time the vehicle is turned on.

The LDW/LDP component of ALA is ready to issue warnings and initiate actions as soon as the vehicle reaches 37 mph (60 km/h) and both lane lines are identified and show on the driver display as solid lane markings. LDP requires both lane lines to be identifiable to function; LDW only requires one lane line to function.

LKA is ready to issue warnings and initiate actions when cruise control is active and when the vehicle is driving forward at approximately 15-20 mph (24-32 km/h).

The status of LKA is shown by the color and design of the steering wheel telltales on the driver display screen.

- Blue hands-on steering wheel: LKA is on and actively steering.
- Grey hands-on steering wheel: LKA is on but inactive (due to glare, snow, bad lane lines, etc.).
- Red hands-on steering wheel: auto stop is active.
- Amber steering wheel with exclamation point: There is a problem with the electro-hydraulic power steering system which deactivates LKA.
- Red steering wheel with exclamation point: There is an error with the adaptive power steering (APS) which deactivates LKA or an error with LKA.
- No steering wheel icon: LKA is off or deactivated.

See Fig. 197, [Active Lane Assist - ICUC](#) and Fig. 198, [Active Lane Assist - ICC5](#) for examples of an LKA status telltale in the driver display.

Auto stop initiates at the end of the LKA hands-on warning cascade and is only activated when LKA is active.

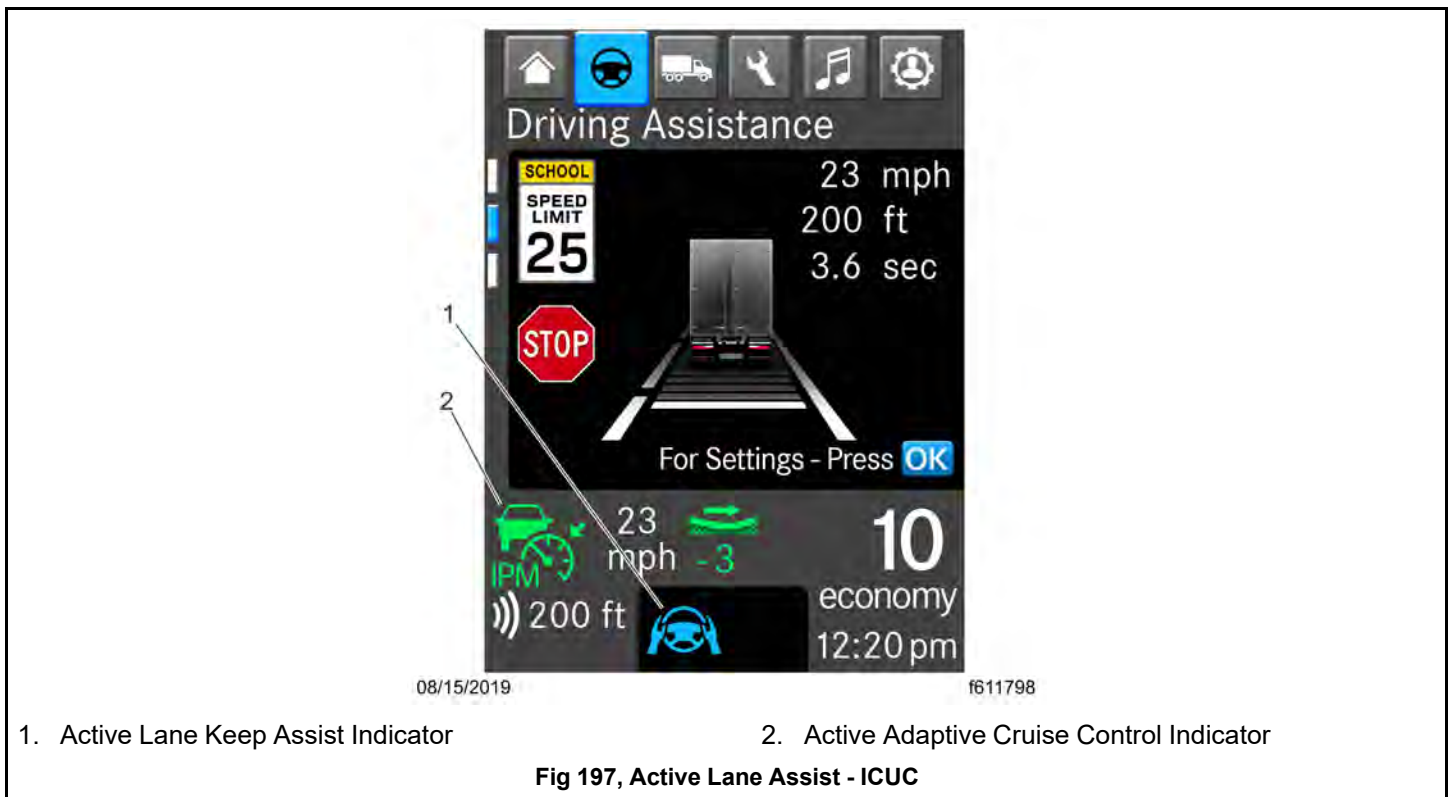

7.08.04 Active Lane Assist (ALA) Functions and Warnings

**WARNING:**

The features in active lane assist (ALA) are intended only as aids for a conscientious and alert driver. Do not rely on ALA to safely operate the vehicle.

The driver is responsible for keeping their hands on the wheel at all times when ALA is active.

ALA may not indicate lane departures under certain conditions. Read the information in this manual to understand the circumstances under which ALA may not provide adequate lane departure warnings.

ALA does not warn of all possible hazards and is not a substitute for safe driving procedures.

Failure to drive safely and use ALA properly could result in personal injury and/or death and severe property damage.

**WARNING:**

The Detroit Assurance Collision Mitigation System is intended solely as an aid for an alert and conscientious professional driver. It is not intended to be relied upon to operate a vehicle. Use the system in conjunction with rearview mirrors and other instruments to safely operate the vehicle.

The Detroit Assurance Collision Mitigation System is not a substitute for safe, normal driving procedures, nor will it compensate for any driver impairment such as drugs, alcohol, fatigue, distraction or inattention.

Operate a vehicle equipped with Detroit Assurance Collision Mitigation System as if the vehicle were not equipped with a collision mitigation system.

Failure to drive safely and use the system properly could result in personal injury and/or death and severe property damage.

ALA works to keep the vehicle within the lane, issues warnings when a driver takes their hands off the steering wheel, and if necessary intervenes to bring the vehicle to a stop.

With the driver's hands on the steering wheel, the LKA feature of ALA engages in micro-steering adjustments to offset side winds, lateral road inclination, and other environmental forces to keep the vehicle in the driver's preferred lane position. To set the preferred lane position, select 'Quick Access' > 'Follow Distance/Lane Position.' Options include: offset to the right, offset to the left, or center. The default lane position is center.

If the micro-steering of LKA cannot compensate for the sideways movement of the vehicle and the vehicle crosses over the lane markings with no turn signal activation, LDW issues a warning as follows:

- The exceeded lane markings appear in red on the driver display screen.
- The volume of the audio equipment and/or hands-free system is muted.
- A warning rumble strip sound is broadcast from the speaker on the side of the exceeded lane markings.

If the driver does not steer the vehicle back into the lane or activate a turn signal, the corresponding lane marker turns red on the driver display and LDP intervenes. An acoustic warning sounds while LDP guides the vehicle back into the center of the lane.

LDW does not issue a warning about traveling over lane markings if:

- a turn signal is switched on;
- a driving safety system, such as ABA, stability control, or ACC intervenes.

LDW only issues a visual warning about traveling over lane markings if the driver is braking, accelerating, or making a sharp turn.

In addition to helping keep the vehicle in the desired lane position, LKA monitors the driver's hands on the steering wheel. If LKA senses the driver's hands are not on the steering wheel, it issues a series of warnings.

If LKA is active and the driver takes their hands off the steering wheel for 15 seconds, an amber caution pop-up window appears telling the driver to return their hands to the steering wheel. Doing so will cause the pop-up window to disappear.

If the driver does not return their hands to the steering wheel, at 30 seconds a red warning pop-up window appears and an acoustical warning starts to sound every five seconds.

If the driver does not return their hands to the steering wheel, at 55 seconds the acoustical warning starts to sound every second.

If the driver does not return their hands to the steering wheel, at 60 seconds the acoustical warning becomes a continuous loud audible warning and auto stop initiates.

As soon as the driver places their hands on the steering wheel, the LKA visual and audible warnings cease and the hands-off count is reset to zero.

LKA becomes inactive when the driver activates a turn signal and when auto stop activates.

LKA deactivates with the intervention of LDW/LDP, the deactivation of ACC, and if deactivated by the driver.

The auto stop feature of LKA activates at the end of the LKA cascade of hands-on warnings and engages the vehicle's service brakes to smoothly bring the vehicle to a complete stop while keeping it within the lane.

During an auto stop activation:

- a warning appears on the driver display stating that auto stop is active and providing override procedures, shown in Fig. 200, [Warning that Auto Stop is Active, ICC5](#);
- the auto stop telltale of a red hands-on steering wheel, shown in Fig. 201, [Auto Stop Telltale](#), appears on the driver's display;
- when auto stop has brought the vehicle to a standstill, the auto stop telltale clears and a caution with the standstill override procedure appears on the driver display; see Fig. 202, [Auto Stop Finished Caution, ICC5](#).

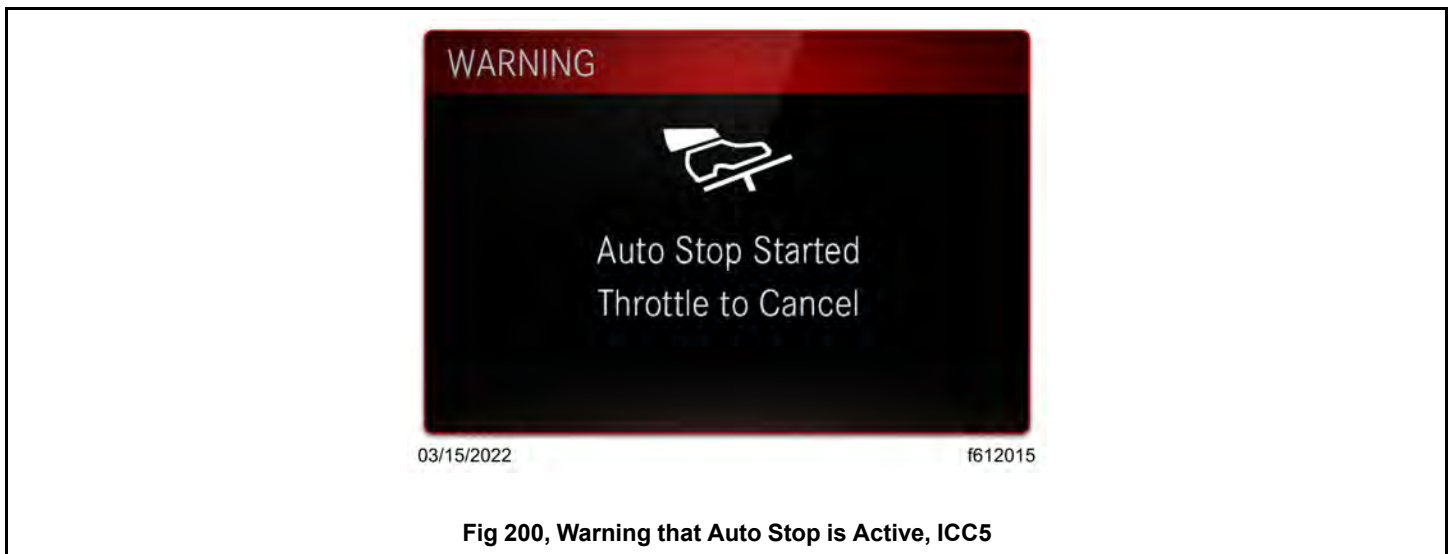

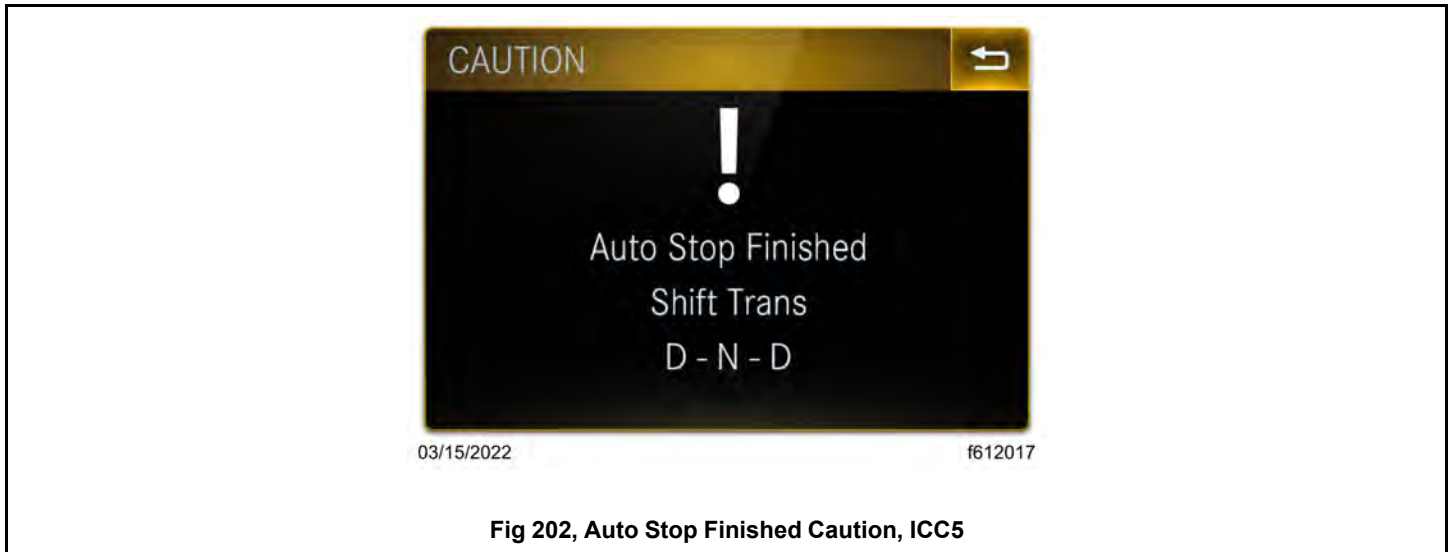

Once auto stop initiates, ACC is canceled. If active, ABA remains active while auto stop slows the vehicle.

After reaching a standstill, auto stop turns on the vehicle's headlights, cabin lights, and hazard lights, applies the hold brakes, and shifts the transmission into neutral.

If auto stop is initiated three times, a notification of misuse appears on the driver display, shown in Fig. 203, [Caution that LKA is Unavailable Due to Detected Misuse - ICC5](#), the auto stop telltale clears, and ALA is deactivated. The driver must restart the vehicle to enable ALA. Deactivation of ALA deactivates LDP, LKA, and auto stop.



Fig 203, Caution that LKA is Unavailable Due to Detected Misuse - ICC5

7.08.05 Active Lane Assist (ALA) Switches



WARNING:

The features in active lane assist (ALA) are intended only as aids for a conscientious and alert driver. Do not rely on ALA to safely operate the vehicle.

The driver is responsible for keeping their hands on the wheel at all times when ALA is active.

ALA may not indicate lane departures under certain conditions. Read the information in this manual to understand the circumstances under which ALA may not provide adequate lane departure warnings.

ALA does not warn of all possible hazards and is not a substitute for safe driving procedures.

Failure to drive safely and use ALA properly could result in personal injury and/or death and severe property damage.



WARNING:

The Detroit Assurance Collision Mitigation System is intended solely as an aid for an alert and conscientious professional driver. It is not intended to be relied upon to operate a vehicle. Use the system in conjunction with rearview mirrors and other instruments to safely operate the vehicle.

The Detroit Assurance Collision Mitigation System is not a substitute for safe, normal driving procedures, nor will it compensate for any driver impairment such as drugs, alcohol, fatigue, distraction or inattention.

Operate a vehicle equipped with Detroit Assurance Collision Mitigation System as if the vehicle were not equipped with a collision mitigation system.

Failure to drive safely and use the system properly could result in personal injury and/or death and severe property damage.

In a vehicle equipped with an ICC5, there are four possible switches related to active lane assist (ALA): two digital and two physical:

- A physical LDW off switch, shown in Fig.204,[Lane Departure Warning Off Physical Switch](#).
- A digital LDW off switch, shown in Fig.205,[Lane Departure Warning Off Digital Switch, ICC5](#).
- A physical LKA off switch, shown in Fig.206,[Lane Keep Assist Off Physical Switch](#).

- A digital LKA off switch, shown in Fig.207, [Lane Keep Assist Off Digital Switch, ICC5](#).

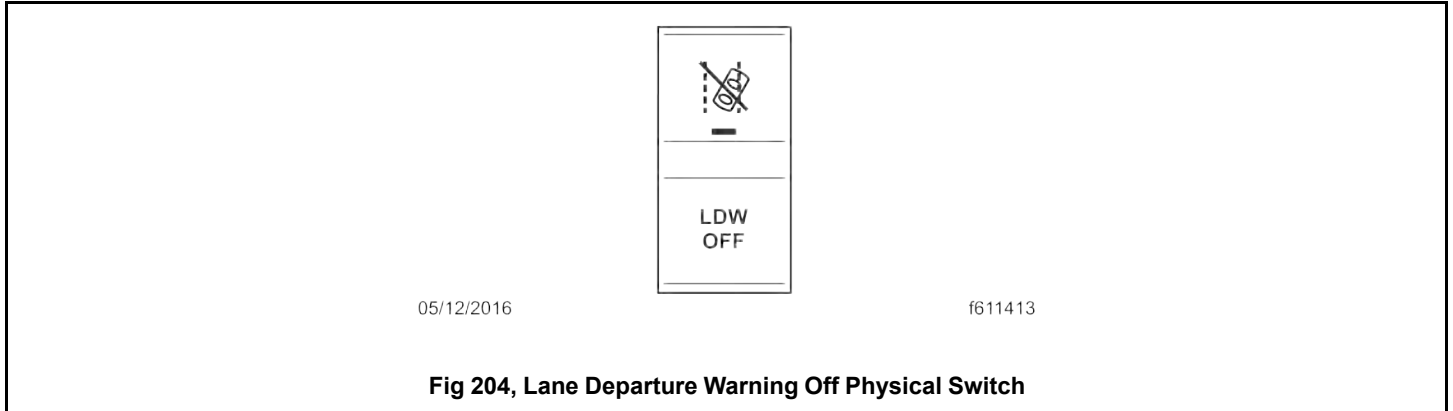



ALA with auto stop can also be deactivated under 'Settings' > 'Driving Assistance.'

Pressing either a physical or digital LKA OFF switch turns off LKA for the key cycle. The switch light illuminates to show that LKA is off. Pressing the switch or restarting the vehicle turns LKA on.

Pressing the LDW OFF switch will turn off LDW and, by extension, LDP for fifteen minutes. When LDW is off, the light on the LDW alert switch illuminates.

7.09 Detroit Assurance Side Guard Assist (SGA) and Active Side Guard Assist (ASGA)

7.09.01 General Information

IMPORTANT: SGA assesses data for objects along the length of the passenger side of the truck and, if present, one trailer. The enhancement, ASGA, only reacts to moving objects within SGA's sensor monitoring area.

SGA detects if a trailer is attached to the truck, but cannot detect whether or not multiple trailers are attached. If used with more than one trailer, SGA only considers objects or stationary obstacles in the range of the truck and the first trailer. False-positive indications and warnings may occur with multiple trailers.

IMPORTANT: SGA and its enhancement, ASGA, are not currently designed to work with non-ABS trailers or on trucks with lift axles.

In a left-hand drive truck, SGA monitors the area to the right of the truck and trailer using two short range radar sensors. The radar sensors are mounted close to the rear of the right-hand footsteps. See Fig. SGA provides assistance when turning right and changing lanes to the right. A triangular warning lamp in the A-pillar, shown in Fig. lights up to inform the driver that an object has been detected in the monitored area. An additional warning tone sounds if there is a risk of collision.

ASGA engages at urban speeds (less than 12 mph). If SGA detects a critical moving object in the sensor monitoring area along the side of the truck during a passenger side turn, ASGA automatically applies the brakes.

In a right-hand drive truck, SGA monitors the area to the left of the truck and trailer. The sensors and warning lamps are located to the left of the driver. All other features remain the same.

Shortly after reversing or coupling up, the trailer monitoring of SGA is not active; therefore the driver cannot switch SGA trailer monitoring on or off for a moment.



02/03/2023

f547736

Fig 208, Radar Sensors with Covers

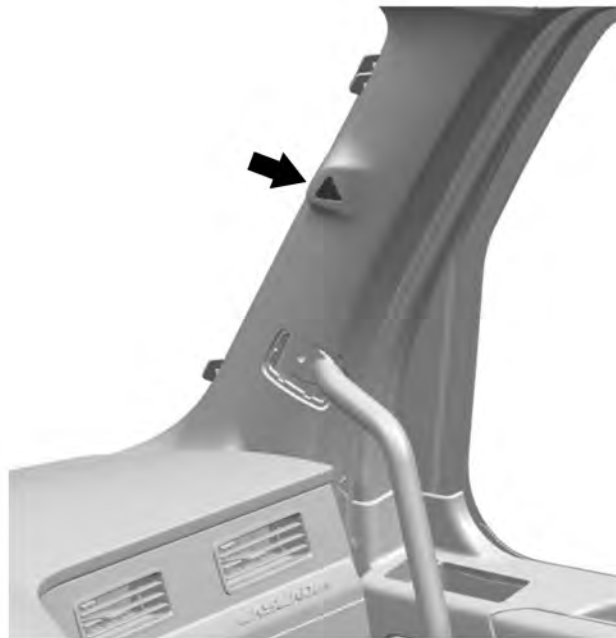

07/19/2022

f547735

Fig 209, SGA Warning Lamp

7.09.02 Safety Information

NOTE: When detection is restricted, SGA may issue a warning too late or not at all. The detection of obstacles can be impaired by the following situations:

- dirty, icy or obscured sensors
- very wide lanes
- vehicles not driving in the middle of their lane
- barriers or other road boundaries

There is a risk of an accident in these situations.

The driver must pay attention to the traffic situation and maintain a safe distance at the side of the vehicle.

SGA is only an aid for a conscientious driver. Depending on the situation and the trailer, SGA may issue a warning prematurely or not at all. SGA and ASGA are not a substitute for attentive driving. Always ensure there is sufficient distance to the side for other vehicles, cyclists, pedestrians, and obstacles.

IMPORTANT: If the sensors are dirty or SGA malfunctions, a grey triangle alert icon appears on the driver display. Objects in the monitoring range are not tracked when this occurs.

Before driving the truck, ensure that the radar sensor cover is free from dirt, ice, or slush. If the sensors get dirty while driving, pull off in a safe location to clean them. The radar sensors must not be painted or covered by items such as stickers.

If the truck is involved in a severe accident or there is damage to the passenger-side footsteps, have the function of the radar sensors checked.

If SGA malfunctions, have the function of the radar sensors checked at an authorized dealer.

7.09.03 Sensor Monitoring Range

As shown in Fig.210, [Sensor Monitoring Area, 2](#) an empty angle of approximately 6 degrees is between the truck and the area monitored by the sensor. Objects within this area are not detected.

Due to the nature of the system, warnings may be issued in error when driving close to barriers or other solid boundaries.

Warnings may also be interrupted when driving alongside particularly long vehicles for a prolonged time.

The SGA system uses the side radar and truck data to assess entrance into the sensor monitoring area. This area depends on speed, turn data, and driver activity. If equipped with ASGA, this enhancement only uses proximity data for moving objects, such as pedestrians or bicycles, located along the length of the passenger side of the truck to apply the brakes.

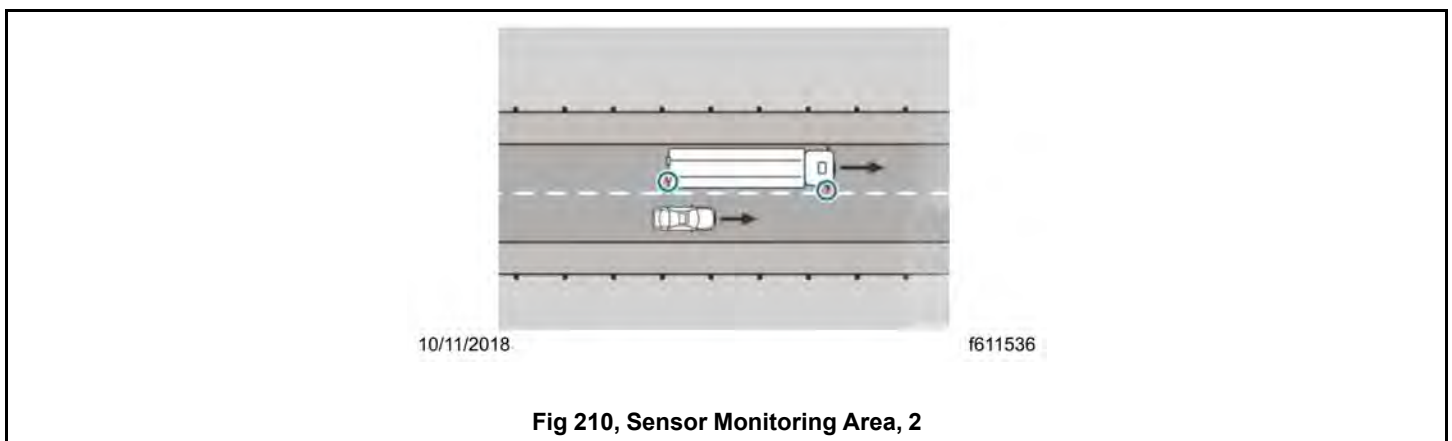

Fig 210, Sensor Monitoring Area, 2

7.09.04 SGA Indicator Lamps

NOTE: Depending on the type of instrument panel installed in the truck, the telltales described as grey may appear white.

| Name | Telltale | Color |
|---|---|-------|
| Side Guard Assist Initializing |  | Grey |
| Side Guard Assist Active |  | Grey |
| Side Guard Assist Error or Deactivation |  | Grey |
| Side Guard Assist Trailer Monitoring Active |  | Grey |
| Side Guard Assist Trailer Monitoring Deactivated |  | Grey |
| Caution, Side Guard Assist |  | Amber |
| Caution, Side Guard Assist Trailer |  | Amber |
| Caution, Side Guard Assist Trailer Monitoring Deactivated |  | Amber |
| Warning, Side Guard Assist |  | Red |
| Warning, Side Guard Assist Trailer |  | Red |
| Warning, Side Guard Assist Trailer Monitoring Deactivated |  | Red |

Table 28, Side Guard Assist (SGA) Lamps

7.09.05 Side Guard Assist Activation Conditions

SGA and, if equipped, ASGA are active when the ignition is turned on. An SGA initializing telltale, the first telltale in Table.30, Side Guard Assist (SGA) Lamps may appear on the driver display during startup.

| Name | Telltale | Color |
|---|---|-------|
| Side Guard Assist Initializing |  | Grey |
| Side Guard Assist Active |  | Grey |
| Side Guard Assist Error or Deactivation |  | Grey |
| Side Guard Assist Trailer Monitoring Active |  | Grey |
| Side Guard Assist Trailer Monitoring Deactivated |  | Grey |
| Caution, Side Guard Assist |  | Amber |
| Caution, Side Guard Assist Trailer |  | Amber |
| Caution, Side Guard Assist Trailer Monitoring Deactivated |  | Amber |
| Warning, Side Guard Assist |  | Red |

Table 30, Side Guard Assist (SGA) Lamps



| | | |
|---|---|-----|
| Warning, Side Guard Assist Trailer |  | Red |
| Warning, Side Guard Assist Trailer Monitoring Deactivated |  | Red |

Table 29, Side Guard Assist (SGA) Lamps

After startup, if a trailer is not attached to the truck, a grey triangle appears on the driver display screen as shown in Fig. 211, [SGA Telltale Locations - ICUC](#) and Fig.212, [SGA Telltale Locations - New Cascadia ICC5](#). If a trailer is attached, a grey triangle with trailer appears.

If SGA monitoring experiences an error or is deactivated without a trailer attached, a grey triangle with a slash appears.

If SGA monitoring is deactivated with a trailer attached, a triangle with a trailer and a slash appears.

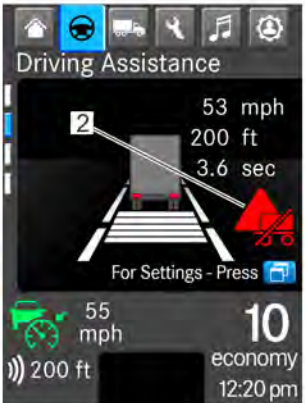
07/21/2022 f612096

NOTE: In a left-hand drive truck, the SGA activation state (grey) telltale appears to the left of center on the driver display driving assistance screen; the amber (not shown) and red warning telltales appear to right of center.

1. Location of SGA Activation State (Grey) Telltale
2. Location of SGA Warning Telltales

Fig 211, SGA Telltale Locations - ICUC



NOTE: In a left-hand drive truck with an ICC5 display, the SGA activation state (grey) telltale (not shown) appears to the right of center on the driver display driving assistance screen; it is replaced by the red warning telltale in the case of a possible imminent collision. The red warning telltale is accompanied by a pulsing red light animation. The amber caution telltale appears to the left of center.

This figure exists to solely to illustrate the SGA telltale locations on the driver display; these telltales will not appear at the same time.

- 1. Location of SGA Amber Caution Telltale
- 2. Location of SGA Activation and Warning Telltales

Fig 212, SGA Telltale Locations - New Cascadia ICC5

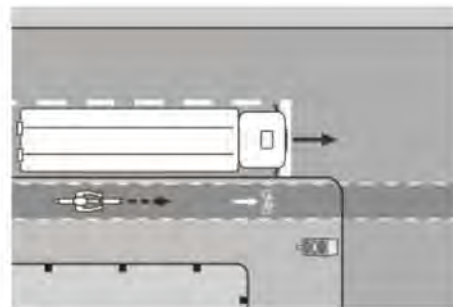

10/11/2018

f611533

Fig 213, Sensor Monitoring Area, 1

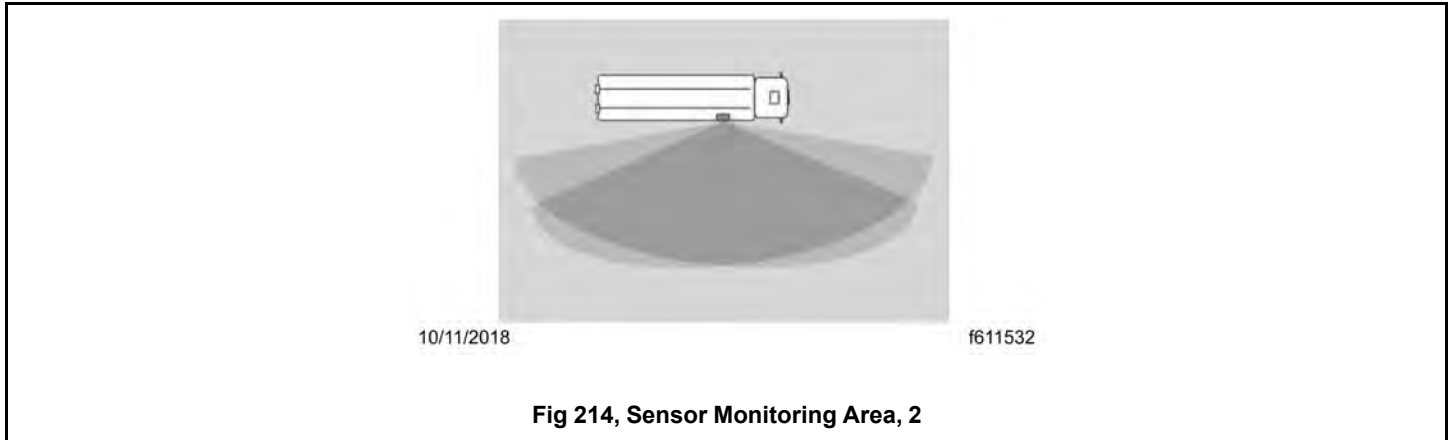

7.09.06 Warnings for Moving Objects

If there is a moving object in the SGA monitoring range, shown in Fig.215, [Sensor Monitoring Area, 1](#) an amber SGA warning lamp in the A-pillar activates and the ICU displays the appropriate SGA caution telltale.

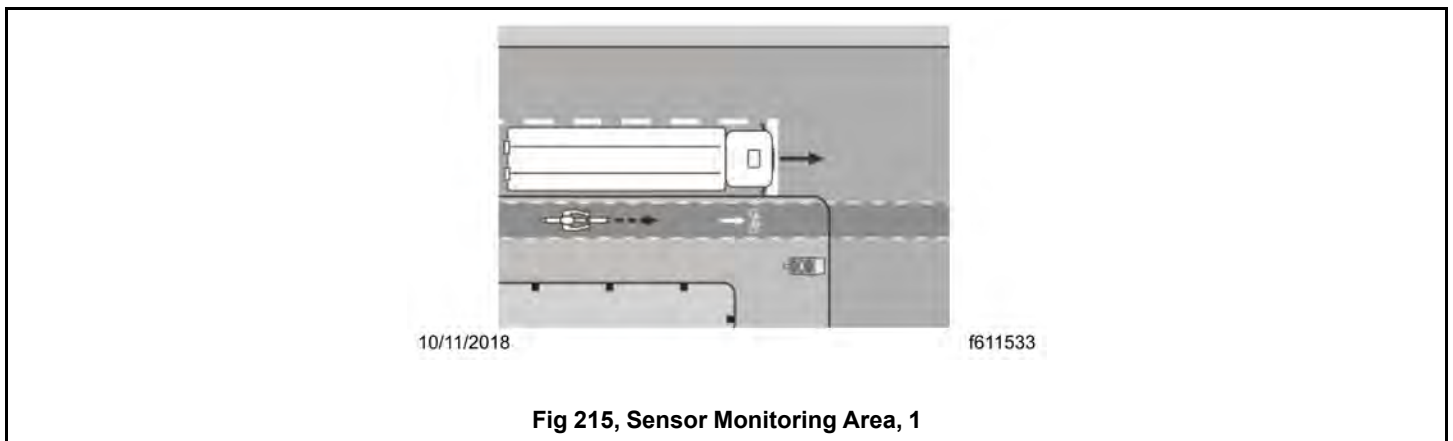

7.09.07 Warnings When Turning Right

SGA recognizes when the driver signals or steers to the right and there is a risk of collision. If equipped, ASGA uses sensor monitoring area parameters to automatically apply the brakes. See Fig.

[216, A Moving Object in the SGA Monitoring Range When Turning Right](#). In this situation, the red SGA warning lamp in the A-pillar flashes for a few seconds, a warning tone sounds, and the ICU displays the appropriate SGA warning telltale. After flashing, the red warning lamp stays on as long as there is a risk of a collision.

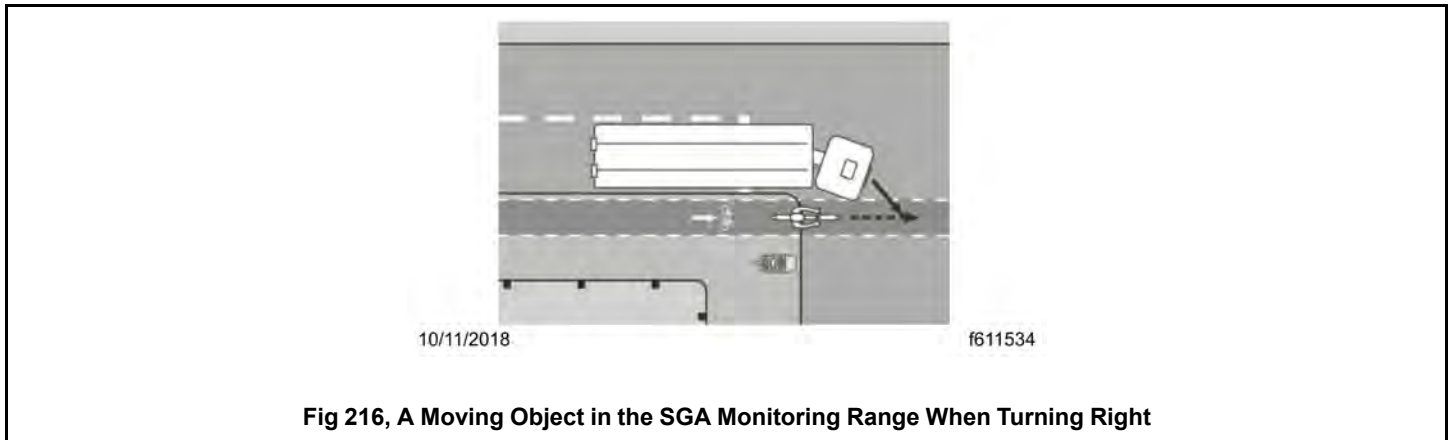

7.09.08 Warnings When Changing Lanes

If there is a moving object in the SGA monitoring range when a driver signals or steers to the right, shown in Fig. 217, [A Moving Object in the SGA Monitoring Range When Changing Lanes](#) an amber warning lamp activates in the A-pillar and the appropriate SGA caution telltale appears on the driver display screen.

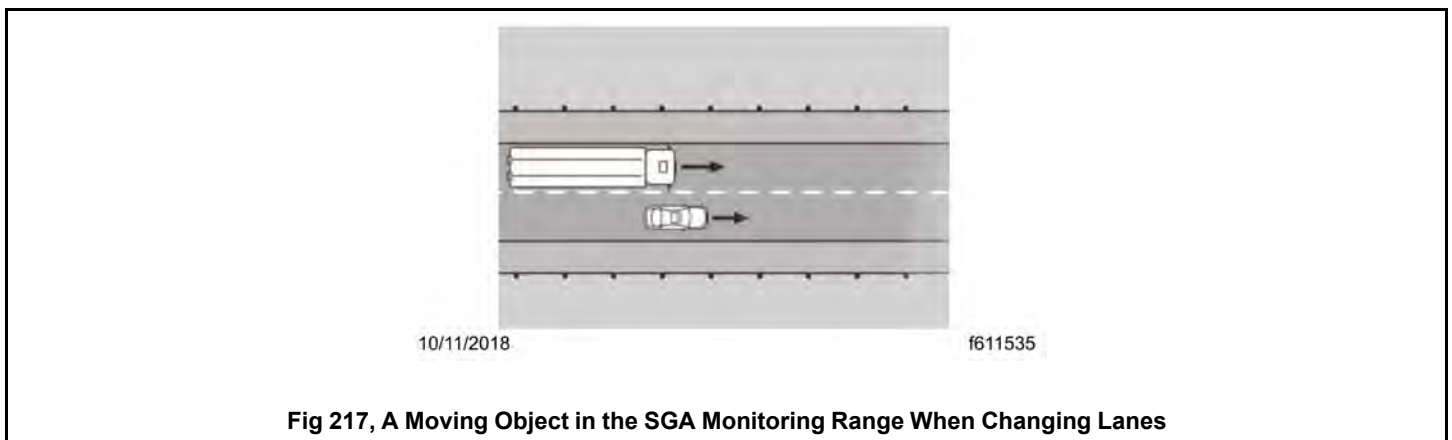

If there is a moving object in the SGA sensor monitoring area when a driver signals or steers to the right, shown in Fig. 218, [A Moving Object in the Sensor Monitoring Area When Changing Lanes](#) the red warning lamp in the A-pillar flashes and a warning tone sounds and the appropriate SGA warning telltale appears on the driver display screen. The red warning lamp stops flashing after a few seconds but stays on as long as there is a risk of a collision.

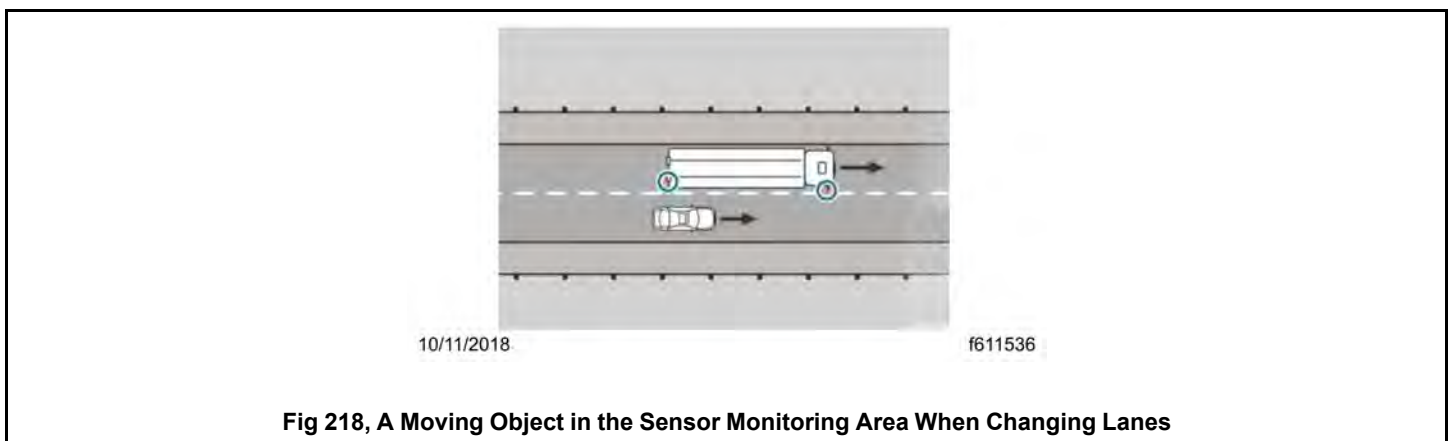

7.09.09 Warnings When Turning Right for Stationary Obstacles

IMPORTANT: SGA is only an aid. It may fail to detect some objects and is not a substitute for attentive driving. Always ensure that there is sufficient distance to the side for vehicles, cyclists, pedestrians, and obstacles.

SGA warns the driver about stationary obstacles in the truck's range of movement up to a maximum speed of 22 mph (35 km/h).

If there is a risk of collision with a stationary obstacle when turning right, the red warning lamp in the A-pillar flashes and a warning tone sounds and the appropriate SGA warning telltale appears on the driver display screen. The red warning lamp stops flashing after a few seconds but stays on as long as there is a risk of a collision.

7.09.10 Activating or Deactivating Side Guard Assist

If activated, SGA and ASGA are on when the truck is turned on.

If the truck is equipped with menu settings, SGA can be deactivated or reactivated on an ICUC system under 'Settings' > 'Safety Systems Settings' > 'More Information' > 'Side Guard Assist' or on an ICC5 under the 'Settings' > 'Driving Assistance' menu.

ASGA relies on SGA and its activation is not controlled separately by the driver. To override the ASGA warning and braking sequence, the driver presses the accelerator pedal past the pressure point to engage kickdown.

7.10 Detroit Assurance Traffic Sign Display

7.10.01 General Information

NOTE: Traffic Sign Display requires IPM to function.

If equipped, the Detroit Assurance Traffic Sign Display system increases road safety by making the driver aware of posted traffic signs. Traffic sign display uses video data from the multipurpose camera in combination with GPS map data to recognize USA and Canadian traffic signs and display them in the instrument panel. GPS information dictates the language and style of the sign display.

7.10.02 Safety Information

Traffic sign recognition and display is only intended as an aid for a conscientious and alert driver. The system may not operate as designed under the following conditions:

- there is low visibility, due to insufficient road illumination or due to snow, rain, fog, or heavy spray;
- there is glare from oncoming traffic, the sun, or reflection from other vehicles when the road surface is wet;
- the windshield is dirty, misted up, damaged, or covered, for instance by a sticker in the vicinity of the camera;
- the traffic signs are partly or fully covered by other vehicles, bushes, or trees;
- the traffic signs are designed in a non-standardized form, with additional text, or as LED panels;
- the traffic signs are damaged, bent, twisted, stained, or scratched;
- the distance from the vehicle in front is too small and prevents the traffic signs from being detected in time;
- the traffic signs are posted on the far side of the road or very high above the road;
- the road is very wide, winding, or has sharp turns;
- there are variable shade conditions on the road surface;
- GPS satellite reception is limited for some reason, such as geographical location;
- onboard map data is outdated due to recent changes in local traffic regulations or new road layout.

The traffic sign recognition system cannot take the road and weather conditions into account, nor the current traffic situation. The driver is responsible for the distance to the vehicle in front, for vehicle speed, braking in good time and remaining in the lane.

7.10.03 Traffic Sign Display Functionality

NOTE: Only three types of USA and Canadian traffic signs are currently detected:

- Speed Limit signs (from speeds 5 to 140)
- Passing signs
- Exclusion signs

See Fig.219, [Recognized Traffic Signs, USA](#) for currently recognized USA signs and Fig. 220, [Recognized Traffic Signs, Canada](#) for Canadian signs.

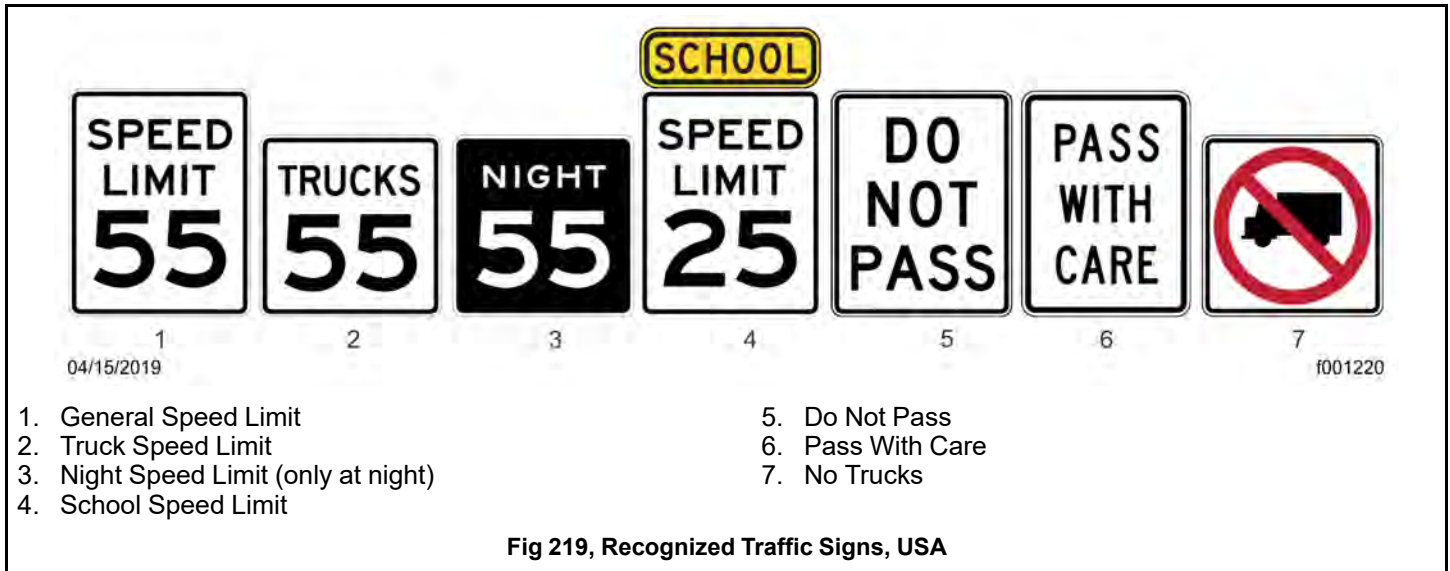

When a traffic sign is recognized by the system, an image representing it appears in the instrument panel. See Fig. 221, [Traffic Sign Display - ICUC](#) and Fig.222, [Traffic Sign Display - ICC5](#) . The ICU will display up to two traffic signs at a time. If more than two signs are recognized by the system, the most safety critical signs will be displayed.

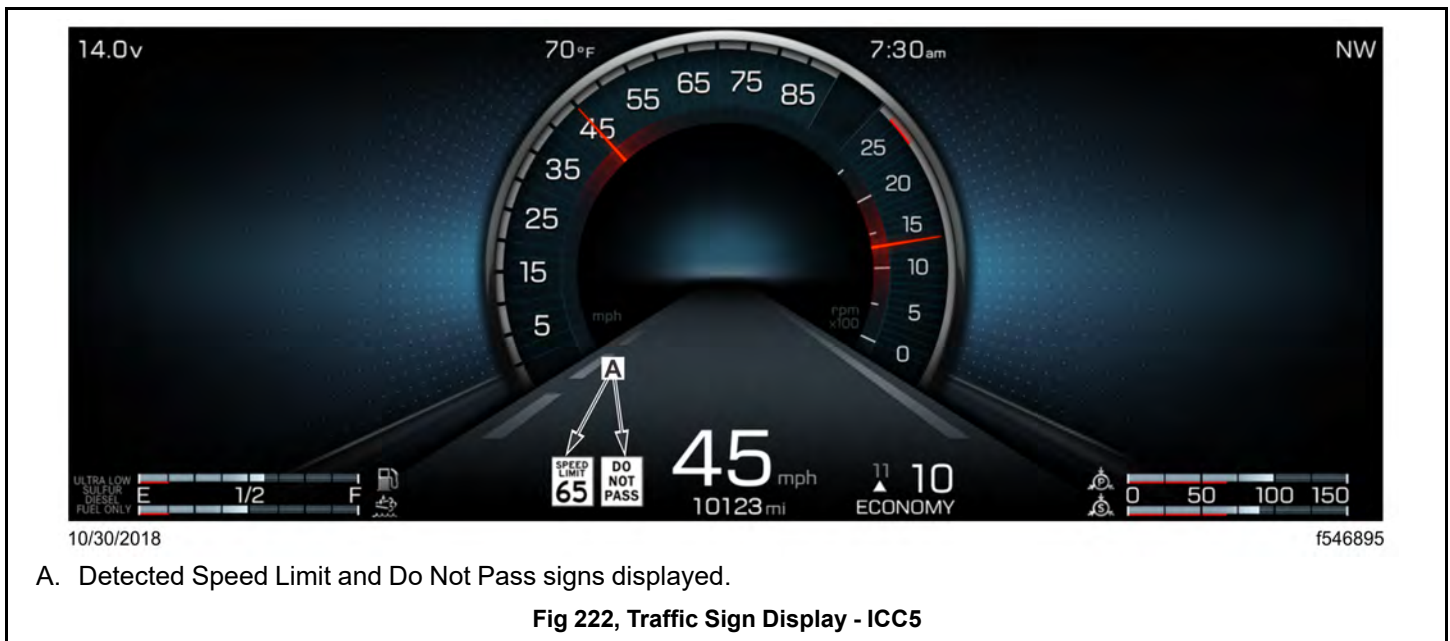
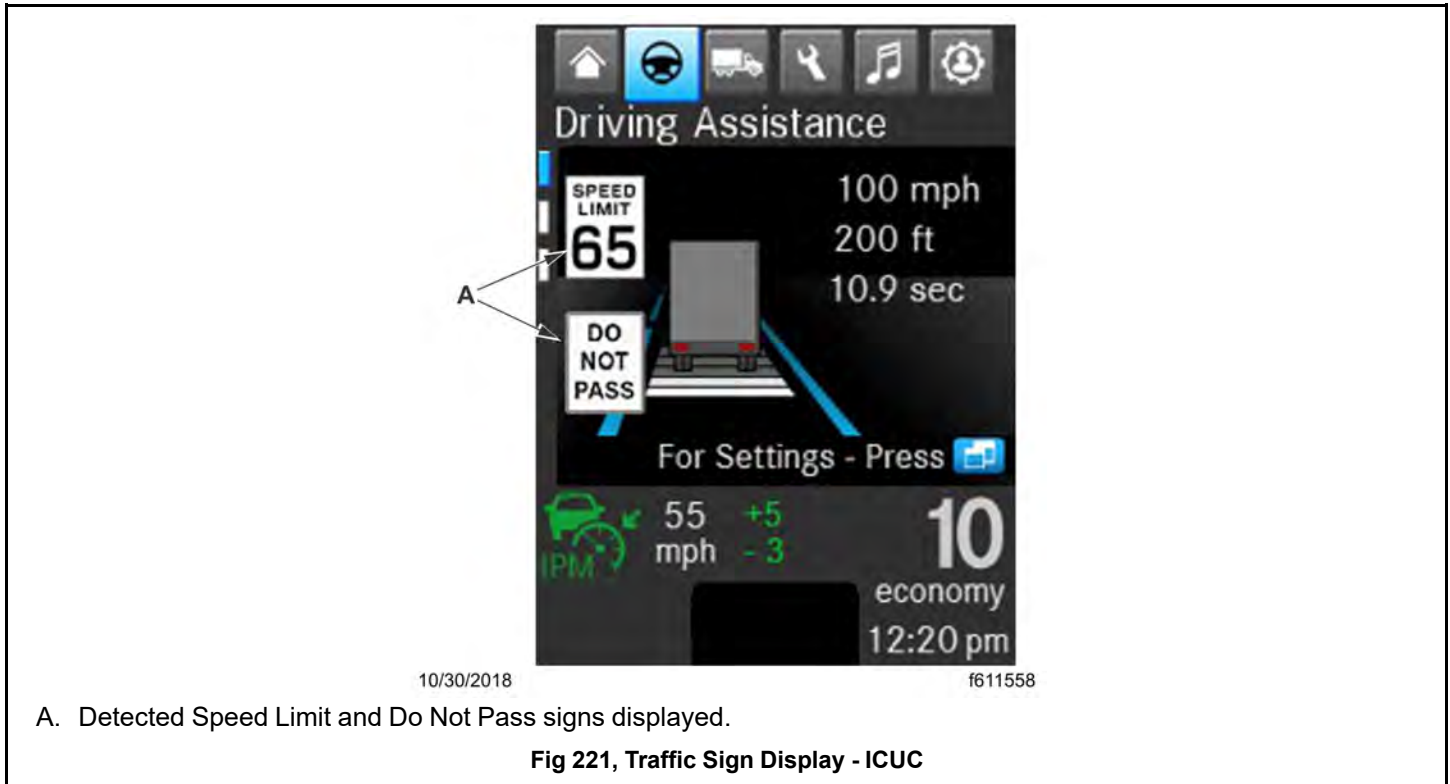

7.10.04 Activating or Deactivating

Traffic Sign Display can be activated or deactivated via menu options in the ICU system.

To activate Traffic Sign Display in an ICUC system:

1. Navigate to "Drive Time Systems."
2. Go to "Safety System Settings."

3. Go to "Sign Recognition."
4. Select "On."

Select 'Off' to deactivate traffic sign display.

To activate Traffic Sign Display in an ICC5 system:

1. Press the center button in either of the steering wheel OFN control buttons
2. Select the "Settings" (gear) icon.
3. Select "Driving Assistance."
4. Go to "Traffic Sign Recognition."
5. Move the selector switch icon to the "On" position (a blue line will appear to the left).

Move the selector switch icon to the 'Off' position to deactivate traffic sign recognition and display

When the ignition is turned on, traffic sign display restores the state of the system (either activated or deactivated) from the last ignition cycle.

7.11 Detroit Assurance Attention Assist

7.11.01 General Information

NOTE: This feature was made available on a very limited number of vehicles and as of 2022 is no longer an option.

If equipped, the attention assist feature issues a warning tone and suggests taking a break when it detects behavior typical of a fatigued driver.

The attention assist warning is shown regardless of legally prescribed driving and rest periods.

The windshield must be kept clean and unobstructed in the area of the camera to ensure that attention assist works properly.

7.11.02 Safety Information

NOTE: This feature was made available on a very limited number of vehicles and as of 2022 is no longer an option.

IMPORTANT: Attention assist is only an aid. It cannot always detect fatigue or lapses in concentration reliably or in time. Attention assist is not a substitute for a well-rested and attentive driver.

As attention assist monitors lane position, it may not operate as designed when the lane position is unclear due to conditions that restrict the multipurpose camera view, low visibility, poor or obscured lane markings, or winding roads.

If there is a significant change in load when the ignition is on, restart the vehicle for attention assist to be available without any restrictions.

Attention assist may also be restricted and a warning may not occur or may be delayed if the driver is predominantly driving slower than 37 mph (60 km/h);

7.11.03 Function and Activation Conditions

NOTE: This feature was made available on a very limited number of vehicles and as of 2022 is no longer an option.

Attention assist is active at speeds above approximately 37 mph (60 km/h).

Attention assist assesses the driver's level of fatigue or lapses in concentration by taking the following into account:

- driving characteristics, such as remaining in the lane and active steering
- trip related details such as the length of the drive
- use of turn signals

- use of the engine brake switch
- uncharacteristic changes in the accelerator pedal position

If attention assist detects typical indicators of fatigue or increasing lapses in concentration on the part of the driver a warning tone sounds and a caution window, shown in Fig.223, [Attention Assist Caution Window - ICUC](#) and Fig. 224, [Attention Assist Caution Window - ICUC](#), appears on the driver display. If ALA has been deactivated, it is automatically reactivated.

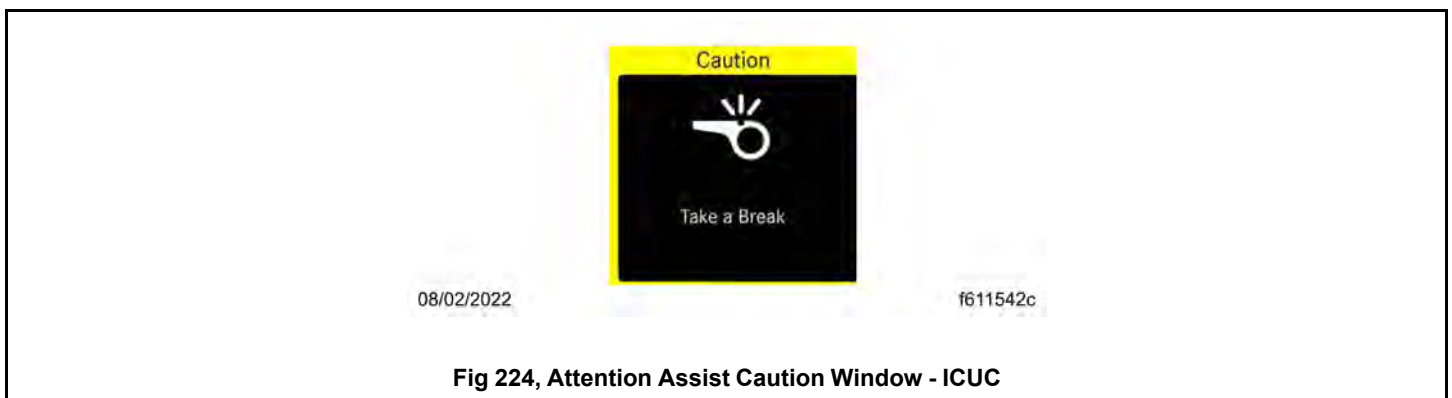
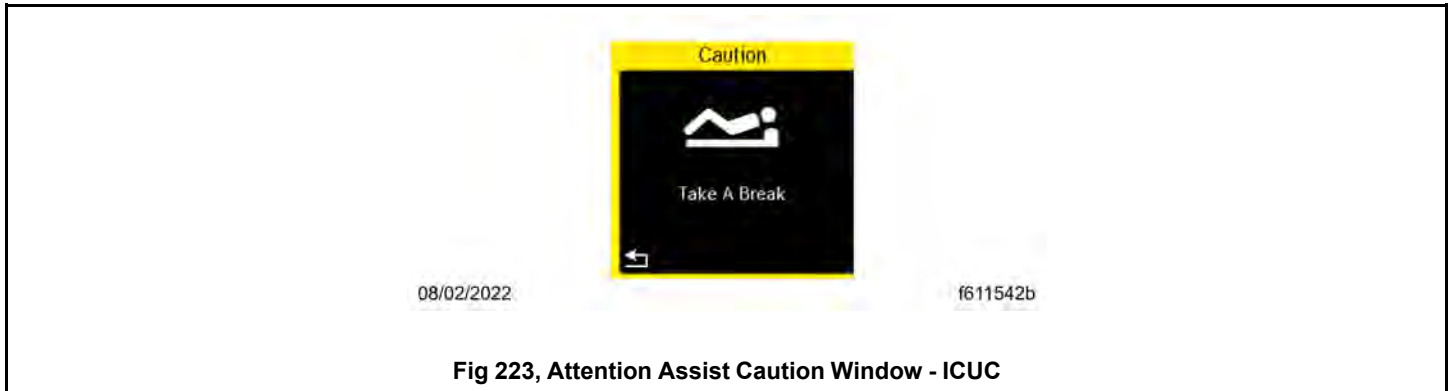

If the driver doesn't take a break when prompted, the soonest attention assist can issue another warning is 15 minutes. When the engine is turned off or the vehicle is stationary for some time, attention assist resets its detection sequence.

7.11.04 Activating or Deactivating

NOTE: This feature was made available on a very limited number of vehicles and as of 2022 is no longer an option.

Attention assist may be deactivated, or activated, in the ICUC instrument panel under 'Drive Time Systems' > 'Safety System Settings' > 'Attention Assist.'

7.12 Lytx SF500 DriveCam System

7.12.01 Driver Facing Camera

If the vehicle is equipped with a Lytx SF500 driver facing camera, there is a Lytx switch on the dash, shown in Fig. 225, [Lytx Dash Switch](#). The LED in the dash switch illuminates when the ignition is on.

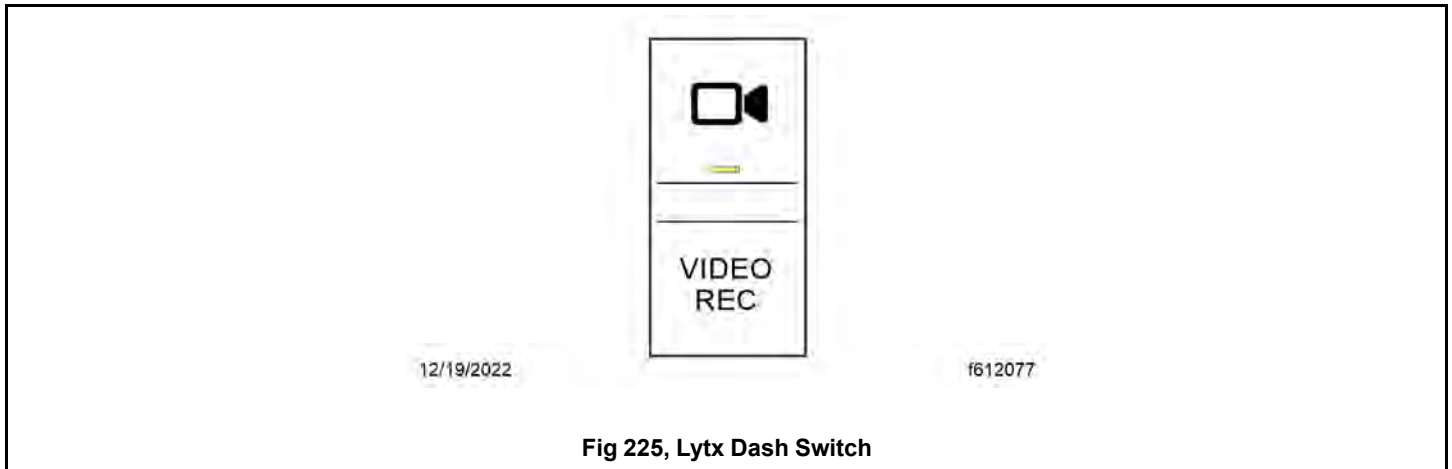

Fig 225, Lytx Dash Switch

The Lytx SF500 DriveCam System constantly captures video, audio, and data from the vehicle to determine when to start recording. If it detects certain behaviors, it records the behavior and plays an audible alert. These alerts cannot be muted.

If the driver wants to initiate a recording, they can press the Lytx dash switch, the system records the next ten seconds.

Videos can be viewed on the Lytx account system which requires approval to access.

The Lytx SF500 DriveCam System automatically turns on a privacy mode when the parking brake is set. When the vehicle is on, it is indicated by a solid blue LED light on the Lytx camera. This mode cannot be initiated by the driver.

To learn more about privacy mode and the meaning of the different LED light patterns on the Lytx SF500 driver facing camera, access the Lytx SF500 DriveCam System User's Manual by scanning the Lytx QR code shown in Fig. 226, [Lytx QR Code Link to Manual](#).



Fig 226, Lytx QR Code Link to Manual

| | |
|--|-----|
| 8.01 Standard Adaptive Cruise Control..... | 259 |
| 8.01.01 General Description, Standard Adaptive Cruise Control | 259 |
| 8.01.02 Using Standard Adaptive Cruise Control | 261 |
| 8.02 PasSmart | 261 |
| 8.03 Intelligent Powertrain Management (IPM)..... | 262 |
| 8.04 Cruise Descent Control and Deceleration Modes | 264 |
| 8.04.01 General Description, Cruise Descent Control and Deceleration Modes | 264 |
| 8.04.02 Descent Control Mode..... | 264 |
| 8.04.03 Deceleration Mode | 265 |
| 8.05 Electronic Stability Control (ESC) | 266 |
| 8.06 Operation of Touch Screen..... | 267 |
| 8.06.01 Tapping | 267 |
| 8.06.02 Single-Finger Swipe | 267 |
| 8.06.03 Two-Finger Swipe | 267 |
| 8.06.04 Touching, Holding and Moving | 267 |
| 8.06.05 Touching and Holding..... | 268 |
| 8.07 Navigation System: ICC5 | 268 |
| 8.07.01 Safety Information..... | 268 |
| 8.07.02 General information | 268 |
| 8.07.03 Global Positioning System (GPS) Reception | 268 |
| 8.07.04 Navigation Menu and Settings | 268 |
| 8.07.05 Navigation Menu..... | 274 |
| 8.07.06 Saving a Destination | 279 |
| 8.07.07 Deleting a Destination | 280 |
| 8.07.08 Planning a Route | 280 |
| 8.07.09 Saving a Route | 281 |
| 8.07.10 Current Route | 282 |
| 8.07.11 During Route Guidance | 284 |
| 8.07.12 Traffic..... | 286 |
| 8.08 AutoVue® Lane Departure Warning System..... | 288 |
| 8.08.01 Overview | 288 |

| | |
|---|-----|
| 8.08.02 System Startup | 288 |
| 8.08.03 Intentional Lane Changes | 289 |
| 8.08.04 Unintentional Lane Departure | 290 |
| 8.08.05 Alert Warnings | 290 |
| 8.08.06 SafetyDirect | 290 |
| 8.08.07 Cleaning the Windshield in the Area of the Camera | 290 |
| 8.08.08 Temporarily Disabling the System | 290 |
| 8.08.09 System Offline Indicators | 291 |
| 8.09 OnGuardACTIVE™ Collision Mitigation System | 291 |
| 8.09.01 General Information | 291 |
| 8.10 Zonar® 2020 Tablet | 297 |
| 8.11 SafetyDirect® by Bendix | 298 |
| 8.11.01 Bendix Forward Facing Camera | 298 |
| 8.11.02 The Bendix SafetyDirect Portal | 299 |

8. Driver Assistance Features

8.01 Standard Adaptive Cruise Control

8.01.01 General Description, Standard Adaptive Cruise Control



WARNING:

Do not use the cruise control system when driving conditions do not permit maintaining a constant speed, such as in heavy traffic or on roads that are winding, icy, snow-covered, slippery, or roads with a loose driving surface. Failure to follow this precaution could cause a collision or loss of vehicle control, possibly resulting in personal injury or property damage.



NOTICE:

When the cruise control is engaged, do not attempt to shift gears without using the clutch pedal. Failure to follow this precaution will result in a temporarily uncontrolled increase in engine speed. Transmission damage and gear stripping could result.

NOTE: If the vehicle is equipped with a Detroit DT12 automated transmission, setting the cruise control with the engine brake on will activate cruise descent control mode. Moving the transmission shift lever to the top position will resume the set cruise speed. Moving the lever down to engage the engine brake after the cruise control has been set will activate deceleration mode. See 'Cruise Descent Control and Deceleration Modes' in this chapter.

In the ICUC, standard cruise control is operated by three switches mounted in the right-hand switch pod of the steering wheel. See Fig.227, [Steering-Wheel-Mounted Right-Hand Switch Pod, ICUC](#).

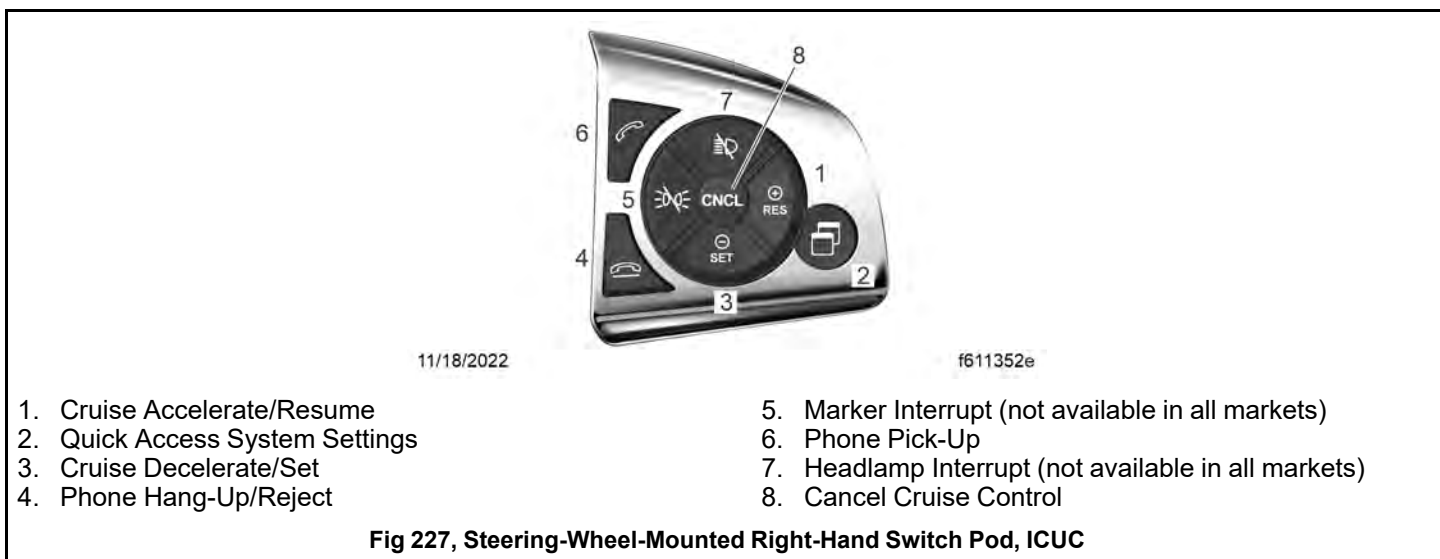

In the ICC5, standard cruise control is operated by three buttons mounted in the left-hand pod of the steering wheel. See Fig.228, [Steering-Wheel-Mounted Left-Hand Switch Pod, ICC5](#).

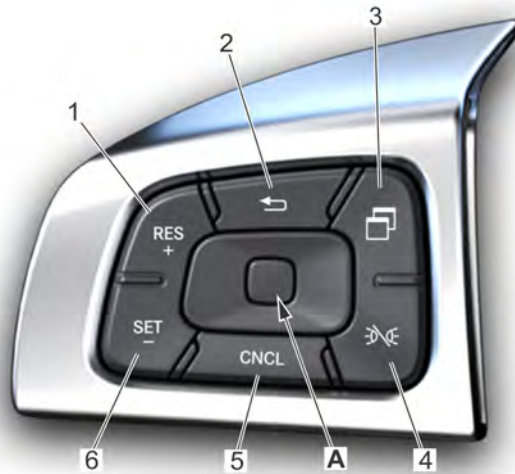

10/25/2018

f611531a

- | | |
|--|--|
| <ul style="list-style-type: none"> A. Menu Button Press the button to access instrument panel menus. When the button is pressed, information appears on the driver display screen. 1. Cruise Accelerate/Resume 2. Back Button | <ul style="list-style-type: none"> 3. Quick Access System Settings 4. Marker Interrupt 5. Cruise Cancel 6. Cruise Decelerate/Set |
|--|--|

Fig 228, Steering-Wheel-Mounted Left-Hand Switch Pod, ICC5

- Cruise Decelerate/SET Button Press to set the cruise speed while the vehicle is traveling at the desired speed. Press and hold to decrease the set cruise speed by 5 mph increments (Detroit Diesel engines only). Single press decreases cruise speed by 1 mph. When cruise control has been set, the driver display static menu in the ICUC shows relevant cruise control icons and the set speed. See Fig.229, [Static Menu, ICUC](#). The speed memory will be retained until the ignition is turned off.

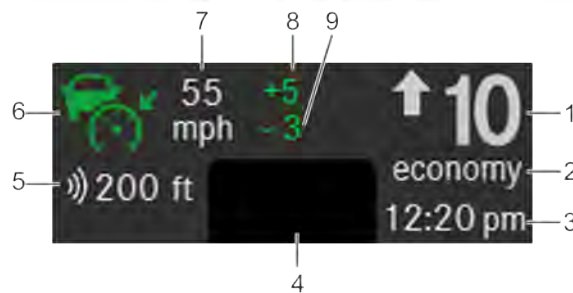

06/13/2016

f611364

- | | |
|--|---|
| <ul style="list-style-type: none"> 1. Gear Indicator 2. Gear mode 3. Time 4. Soft Telltale Area 5. Adaptive Cruise Control Following Distance | <ul style="list-style-type: none"> 6. Adaptive Cruise Control Telltale 7. Cruise Control Set Speed 8. Cruise Control Overspeed Amount 9. Cruise Control Underspeed Amount |
|--|---|

Fig 229, Static Menu, ICUC

- CNCL Button Press to pause the cruise control, while retaining the speed setting in memory. The cruise control can also be disengaged, while retaining the speed memory, by depressing the brake or clutch pedals.
- Cruise Accelerate/RES Button Press to resume the set speed. Press and hold to increase the set cruise speed by 5 mph increments (Detroit Diesel engines only). Single press increases cruise speed by 1 mph. If no previous set speed is stored, pressing the button sets the cruise speed.

8.01.02 Using Standard Adaptive Cruise Control

1. To cruise at a particular speed:
 - 1.a Depress the accelerator pedal until the speedometer reaches the desired speed.
 - 1.b Press the cruise decelerate/SET button to set the desired speed.

NOTE: The set speed memory is lost whenever the ignition is turned off.

2. To disengage the cruise control, do one of the following:
 - Press the CNCL button in the center of the right-hand steering-wheel-mounted switch pod. A single press disengages the cruise control, but retains the set speed.
On vehicle's equipped with a Detroit Diesel engine, press and hold the CNCL button to clear the set speed.
 - In the ICC5 system, press the CNCL button at the bottom of the left-hand control pod. A single press disengages the cruise control, but retains the set speed.
On vehicle's equipped with a Detroit Diesel engine, press and hold the CNCL button to clear the set speed.
 - Depress the brake pedal.
 - If equipped with a manual transmission, press the clutch pedal.
3. To resume a preselected cruise speed, press the cruise accelerate/RES button. Cruise will return to the last set speed.

NOTE: If vehicle speed drops below the minimum cruise control speed, cruise control will disengage. To resume to the preselected cruise speed, increase vehicle speed to above minimum cruise control speed and press the cruise accelerate/RES button.

4. To increase cruise speed, press the cruise accelerate/RES button until the desired set speed is displayed.
5. To decrease cruise speed, press the cruise decelerate/SET button until the desired set speed is displayed.

The cruise speed hysteresis (maximum speed above and below the set speed) can be set in the ICU settings menu. The leading vehicle following distance can be set using the quick access button.

8.02 PasSmart

A standard feature on fleet vehicles, PasSmart enables a vehicle to exceed a set speed limit by a limited amount to allow for passing vehicles on the highway. For example, a PasSmart vehicle may be programmed to enable the vehicle to travel 5mph over a set speed limit for 30 minutes every 24 hours. This speed limiting increases overall fuel economy.

If equipped, the PasSmart function is initiated by double-pumping the accelerator pedal within a two second period. When initiated, the PasSmart window as shown in Fig.230, [PasSmart Active Window, ICC5](#) appears. The PasSmart timer shown in this window starts when the road speed limit is exceeded by 1.89 mph (3 km/h).



Fig 230, PasSmart Active Window, ICC5

PasSmart does not disengage cruise control. After engagement, PasSmart deactivates when the speed limit of the vehicle drops below the cruise control standard set speed limit at which point cruise control resumes.

Thirty seconds before a daily PasSmart limit is reached, the PasSmart active window, if closed, opens to notify the driver of the time remaining.

8.03 Intelligent Powertrain Management (IPM)

NOTE: IPM is standard with a DT12 transmission; IPM is not available with an Eaton or Allison transmission.

IPM is an optional fuel savings application that functions as a predictive cruise control. Using 3D digital map technology and GPS, IPM evaluates the upcoming road grade about a mile in advance to determine the best use case for most fuel-efficient vehicle speed and gear selection.

The IPM active telltale illuminates on the driver display when an IPM mode is activate. See Fig. 231, [IPM Active Telltale, ICUC](#).

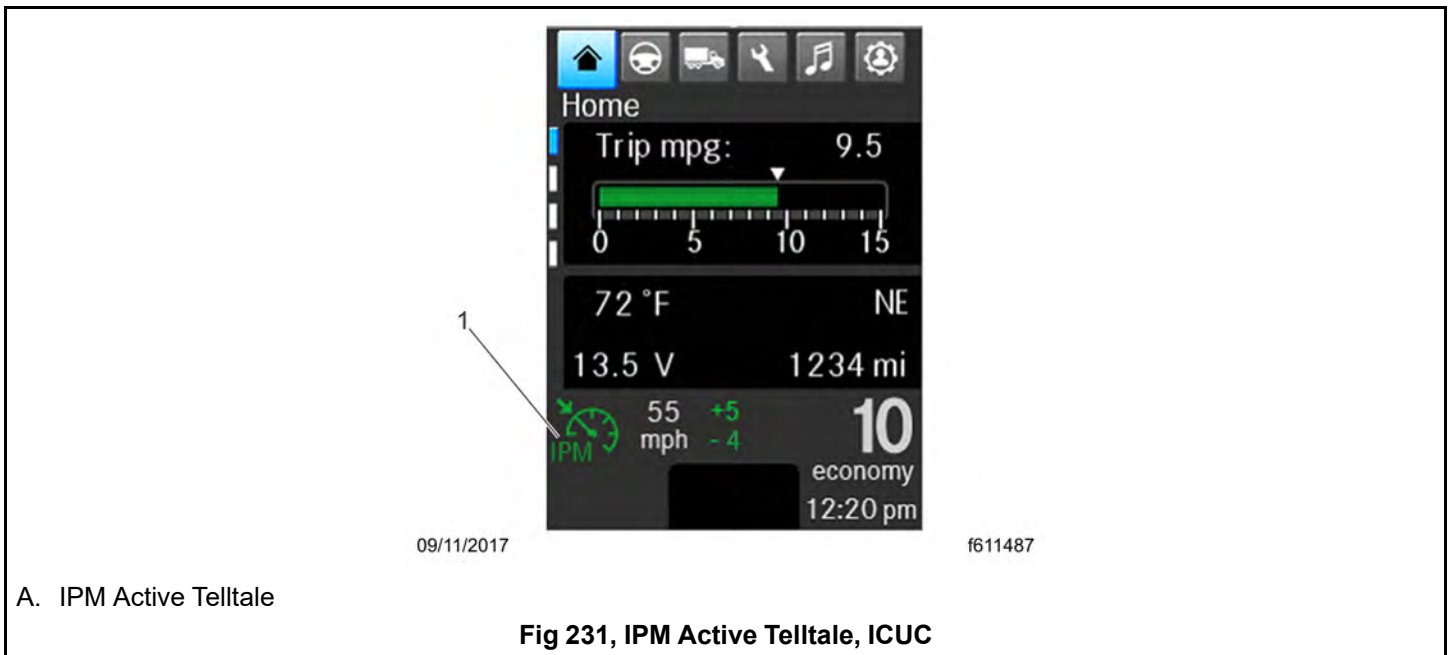

A. IPM Active Telltale

Fig 231, IPM Active Telltale, ICUC

The 3D digital map database contains profile information for over 200,000 highway miles (322,000 km) in the 48 contiguous United States, the Trans-Canada Highway, and most major Canadian highways.

Using these maps, IPM will vary the cruise speed, depending on the approaching road grade.

For a vehicle equipped with the Economy Package, the default variance is +5/4 mph (+8/6 km/h). If the engine brake is enabled, IPM may automatically engage the engine brake at speeds higher than the cruise set speed.

Key predictive features of IPM are:

- Steep Mountain Mode applies if the vehicle will not maintain cruise set speed while climbing. To balance travel time while saving fuel, the vehicle will first predictively accelerate before starting the climb, and may slow down as it approaches the crest of the hill. In this scenario the speed is allowed to fall below the cruise control underspeed.
- Crest Coasting reduces speed before cresting a hill
- Dip Coasting increases speed before a dip
- Predictive Shifting selects a gear shifting strategy for upcoming terrain
- Load Balancing maintains most efficient power for near zero road grades; small fluctuation in road speed may be seen from cruise set speed by ± 1 or 2 mph
- Predictive Adaptive Cruise Control if equipped with adaptive cruise control (ACC), allows IPM to increase following distance

IPM behavior is different from that of conventional cruise control. The system incorporates features to improve the overall driver experience. Some key points to remember are:

- IPM is active only when cruise control is engaged.
- IPM only controls speed within the upper and lower bounds of the cruise set speed. The upper and lower set limits may be exceeded up to 2 mph (3 km/h) for a limited time during dip coasts, as IPM predicts the terrain demands for the most fuel-efficient performance. The driver is responsible for setting a speed appropriate for the conditions and grade. If equipped, IPM upper and lower bounds can be adjusted by selecting the quick access button on the steering wheel.
- IPM can engage eCoast sooner, later, or not at all compared to conventional cruise control.
- IPM may automatically engage the engine brake at a higher speed than the cruise set speed.
- If IPM becomes unavailable, conventional cruise control can still function.

**WARNING:**

Apply the brakes and downshift as necessary when driving on downhill grades. IPM does not adequately control vehicle speed on steep downhill grades. Failure to use normal braking techniques when IPM is active could result in personal injury and vehicle damage.

IMPORTANT: IPM adjusts the vehicle set speed to achieve maximum fuel economy, but it does not account for traffic flows or surrounding vehicles.

For best fuel-savings, use cruise control whenever possible. Driver interaction with IPM is the same as conventional cruise control, using the standard cruise control buttons. In the event of a problem with IPM, or when driving on a road with no profile information available, the system reverts to conventional cruise control.

Using the accelerator pedal will cancel the current IPM session. Disengaging the cruise control will also deactivate IPM.

8.04 Cruise Descent Control and Deceleration Modes

8.04.01 General Description, Cruise Descent Control and Deceleration Modes

NOTE: As a feature of cruise control, descent control mode will work with all transmission options; however, cruise control can only request a specific gear if the vehicle is equipped with a DT12. Descent control mode with transmissions other than D12 is therefore limited.

On vehicles equipped with a Detroit DT12 automated transmission, the functions of the engine brake controls change, depending on which specialty braking mode is being utilized. Two distinct modes can be activated:

- **Descent control mode:** engine braking attempts to maintain a set speed; the accelerator pedal is not automatically applied. Setting the cruise control speed with the engine brake on will activate cruise descent control mode. Moving the transmission shift lever to the top position will resume the set cruise speed.
- **Deceleration mode:** engine braking activates to reduce vehicle speed (with no lower limit) at a constant rate. Moving the transmission shift lever down to engage the engine brake after the cruise control has been set will activate deceleration mode.

8.04.02 Descent Control Mode

NOTE: Before engaging descent control, determine an appropriate speed for the vehicle's load and grade of the road.

Descent control mode attempts to keep the vehicle speed at the set speed using all available engine brake stages when descending a grade.

To activate descent control mode:

1. Exit cruise control.
2. Remove your foot from the accelerator pedal.
3. Set the engine brake to any of the three 'on' positions (positions 1, 2, or 3 in Fig. 232, [Descent Control Mode Engine Brake Positions](#)).
4. Use the set or resume buttons to set the vehicle speed.

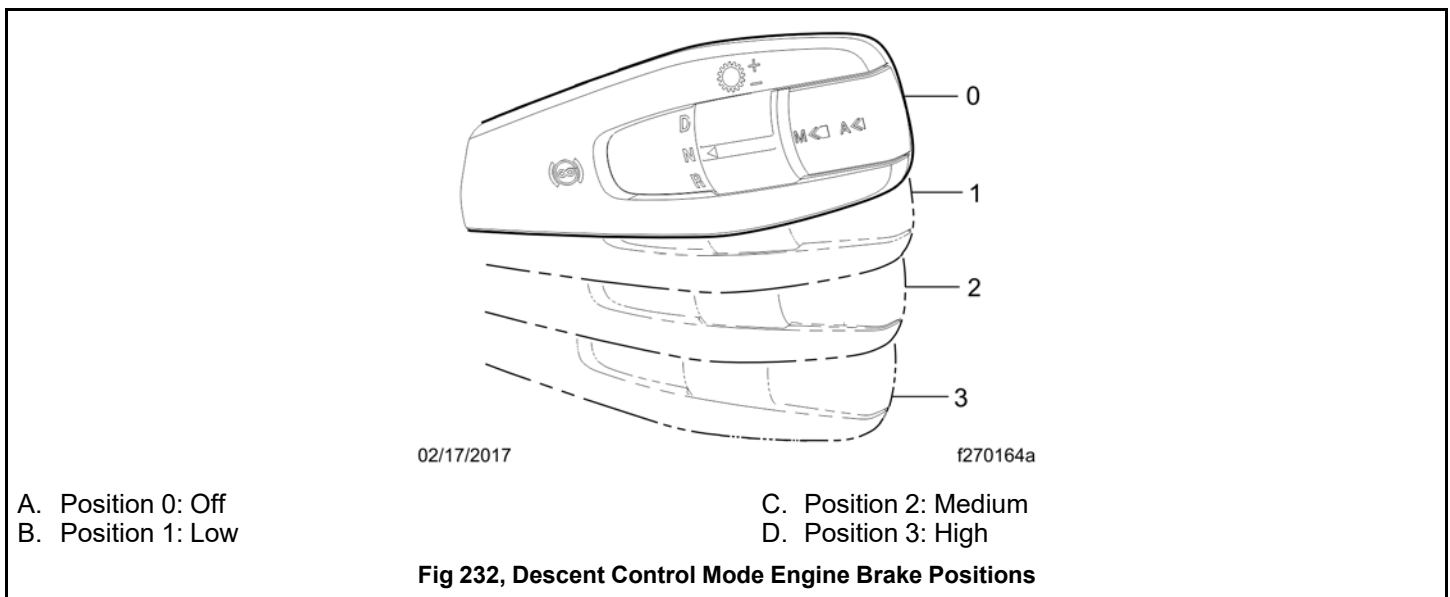

The descent control mode active telltale illuminates on the driver display when descent control mode is active. See Fig. 233, [Descent Control Mode Telltale, ICUC](#).

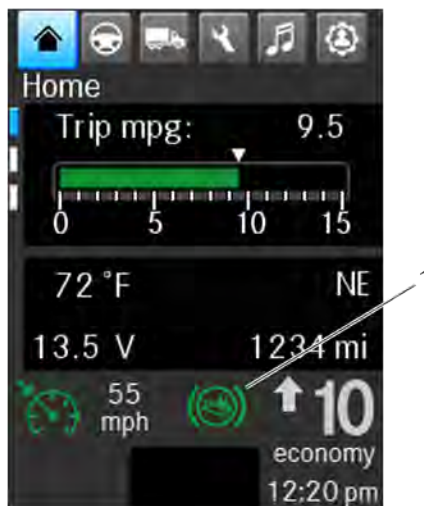

1. Descent Control Mode Active Telltale

Fig 233, Descent Control Mode Telltale, ICUC

In descent control mode, all three levels of engine braking will be employed to keep the speed below the set speed regardless of the level selected by the right-hand stalk switch.

In the case of very steep road grades, the engine brake may not be able to maintain the vehicle speed. The driver may apply the service brakes without dropping out of descent mode to slow the vehicle. If the vehicle is slowed below the set speed, this lower speed will become the set speed after the driver releases the service brakes. In this instance, a pop-up window in the ICU will notify the driver a new set speed was captured as shown in Fig. 234, [Descent Mode Speed Set Notification, ICUC](#).



Fig 234, Descent Mode Speed Set Notification, ICUC

Descent control mode will not keep the speed above the lower limit of the set speed, so it is possible to eventually coast to a stop, unless the stalk lever is moved to 'off' (position 0), or the accelerator pedal is applied.

After accelerator pedal application, descent control mode is resumed.

Moving the lever to the 0 position deactivates descent control mode and resumes cruise control, using the descent control set speed as the cruise control set speed.

8.04.03 Deceleration Mode

Deceleration mode reduces the vehicle speed at a constant rate.

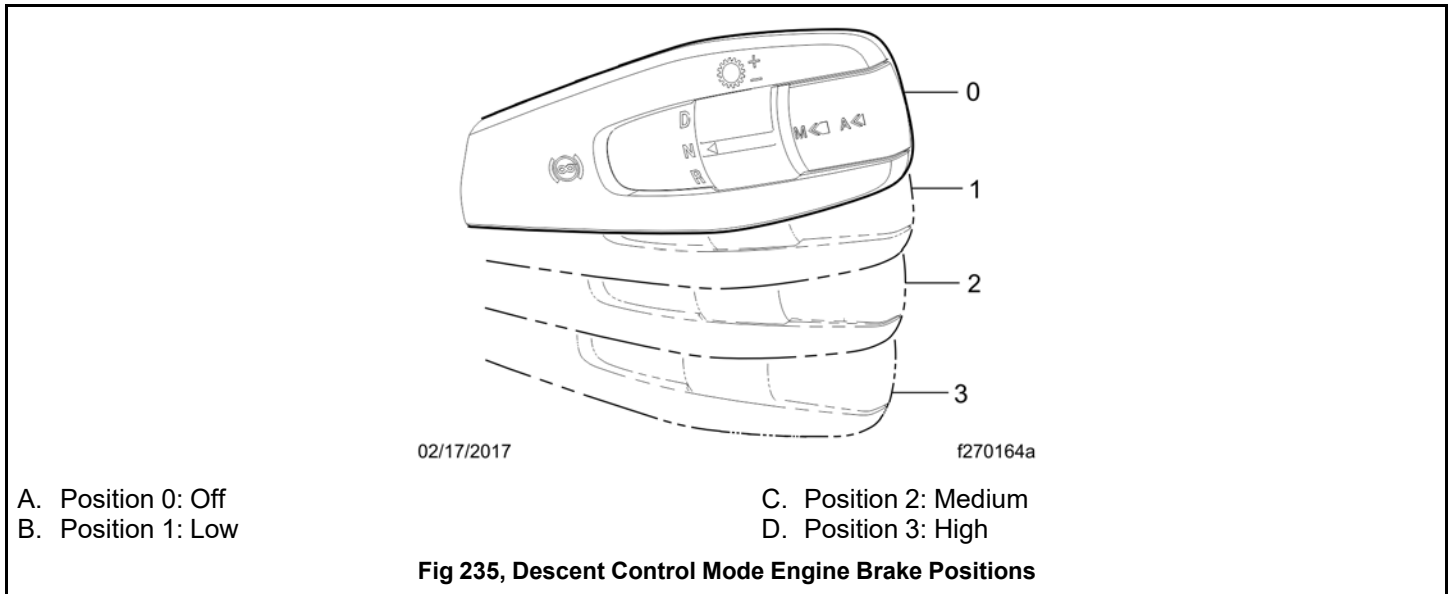

While in cruise control, activate deceleration mode by turning on the engine brake (Fig. 235, [Descent Control Mode Engine Brake Positions](#), lever position 1, 2, or 3). The vehicle will decelerate at a constant rate until the vehicle comes to a stop, unless the accelerator pedal is applied to override the deceleration, or the right-hand stalk switch is moved to 'off' (position 0).

Moving the lever to position 0 resumes the previously set cruise control speed.

8.05 Electronic Stability Control (ESC)



WARNING:

ESC is intended only as an aid for a conscientious and alert driver. Carefully read the information in this manual to understand this system and its limitations. ESC is not a substitute for safe driving procedures. Failure to drive safely, and use the system properly, could result in personal injury and/or death and property damage.



CAUTION:

Changing or modifying the location of the ESC sensor or reconfiguring the vehicle, such as by changing the wheelbase or adding axles, can change the performance of the enhanced stability control system and may result in product or property damage and personal injury.

Electronic stability control (ESC) works by constantly comparing the driver's intention with the vehicle's actual behavior. The system does this by monitoring wheel speed, steering angle, yaw rate, lateral acceleration, throttle position, and brake application. A central microcomputer analyzes the collected data and triggers a response to keep the vehicle on course when an unstable condition is detected.

When the system detects that the vehicle is at risk of over-steering or under-steering, it applies individual tractor wheel end brakes and trailer brakes and/or cuts power to reduce the likelihood of a drift-out or jackknife.

If the acceleration sensor detects the vehicle is at risk of rolling over, the roll stability control system within the ESC automatically reduces power and applies the brakes.

Yaw control is not active below approximately 6 mph (10 km/h). Roll stability control is not active below approximately 12 mph (20 km/h). At higher speeds, ESC operates automatically; the driver does not monitor or activate the system.

The driver has full control over the vehicle until the system detects a potential risk and intervenes accordingly.

The ESC telltale, as shown in Fig.236, [Electronic Stability Control \(ESC\) Telltale](#), appears on the driver display when ESC intervenes and when ESC is unavailable due to a fault. The ESC telltale flashes when an ESC event is actively occurring and is solidly illuminated when ESC is unavailable due to a fault.



It is normal for the ESC telltale to illuminate shortly after a curve, lane change, or other driving maneuver that results in ESC detecting a rollover-risk.

8.06 Operation of Touch Screen

8.06.01 Tapping

IMPORTANT: All keyboard entries are locked when the parking brake is disengaged. Other touch screen options still function.

Tap the touch screen to:

- Select a menu item or entry: tap on a symbol or an entry.
- Increase the map scale: tap twice quickly with one finger.
- Reduce the map scale: tap with two fingers.
- Enter characters with the keyboard: tap on a button.

8.06.02 Single-Finger Swipe

Use a single-finger swipe to:

- Navigate in menus: swipe up, down, left or right.
- Move the digital map: swipe in any direction.

8.06.03 Two-Finger Swipe

Use a two-finger swipe to:

- Zoom in and out of the map: move two fingers together or apart.
- Turn the map: turn counterclockwise or clockwise using two fingers.

8.06.04 Touching, Holding and Moving

Touch, hold, and move the finger to:

- Move the map: touch the touchscreen and move the finger in any direction.

- Set the volume on a scale: touch the touchscreen and move the finger to the left or right.

8.06.05 Touching and Holding

Touch and hold to:

- Call up a global menu in the applications: touch the touchscreen and hold until the OPTIONS menu appears.

8.07 Navigation System: ICC5

8.07.01 Safety Information



WARNING:

There is a risk of distraction from operating integrated communication equipment while the vehicle is in motion.

The driver can be distracted from the traffic situation if operating communication equipment integrated in the vehicle when driving, possibly causing loss of control of the vehicle.

Only operate this equipment when the traffic situation permits. Otherwise, stop the vehicle while paying attention to road and traffic conditions and operate the equipment while the vehicle is stationary.

The driver must observe the legal requirements of the country when operating the system.

The navigation system calculates the route to the destination **without** taking some of the below conditions into account:

- Traffic lights
- Stop signs and right-of-way signs
- Parking lot and stopping restrictions
- Road narrowing
- Other road, traffic controls, and regulations

The navigation system may provide incorrect navigation announcements if the surroundings do not correspond to the data on the digital map, for example: a route may have been diverted or the direction of a one-way street may have changed.

8.07.02 General information

The navigation system calculates the route to the destination and provides navigation announcements.

8.07.03 Global Positioning System (GPS) Reception

Position finding and route guidance take place using the Global Positioning System (GPS). Correct functioning of the navigation system depends, among other things, on GPS reception. In certain situations, GPS reception may be impaired due to interference or there may be no reception at all, for example in some places like tunnels or multistory parking lots.

8.07.04 Navigation Menu and Settings

General Description

Open Navigation and Select  Menu. See Fig.237, [Pre-Trip Planning Navigation Map - ICC5](#) for a map and see Fig. 238, [Navigation Menu Icons - ICC5](#) for the navigation menu.

NOTE: The route view appears on the screen as soon as the vehicle is moving.

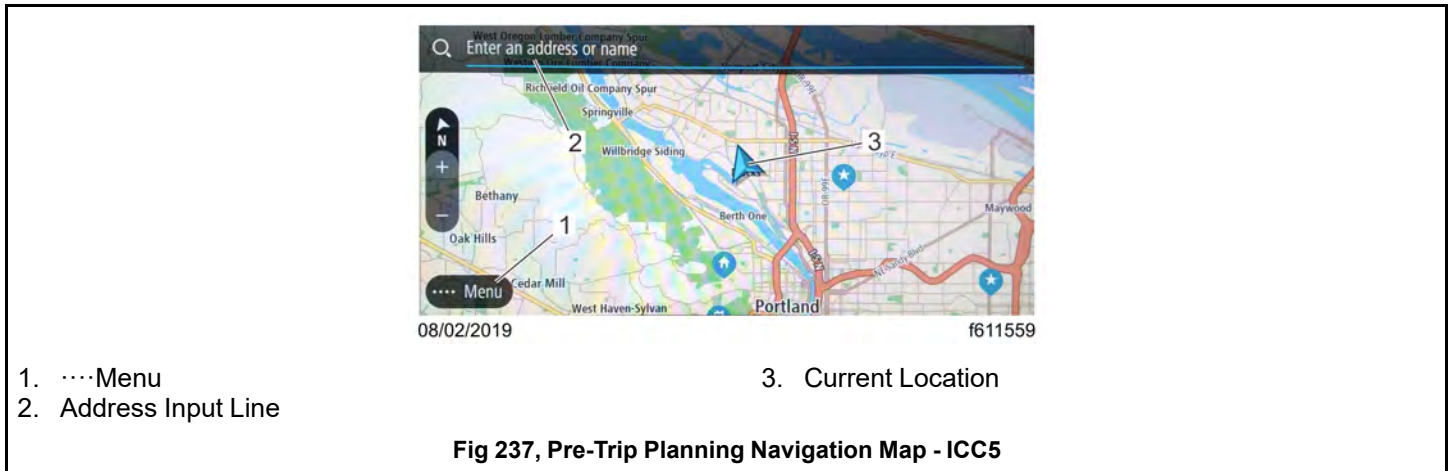

The basic navigation map shows the current vehicle's location, presents a navigation address entry bar, and aMenu button. A known destination address may be entered here or theMenu button selected.

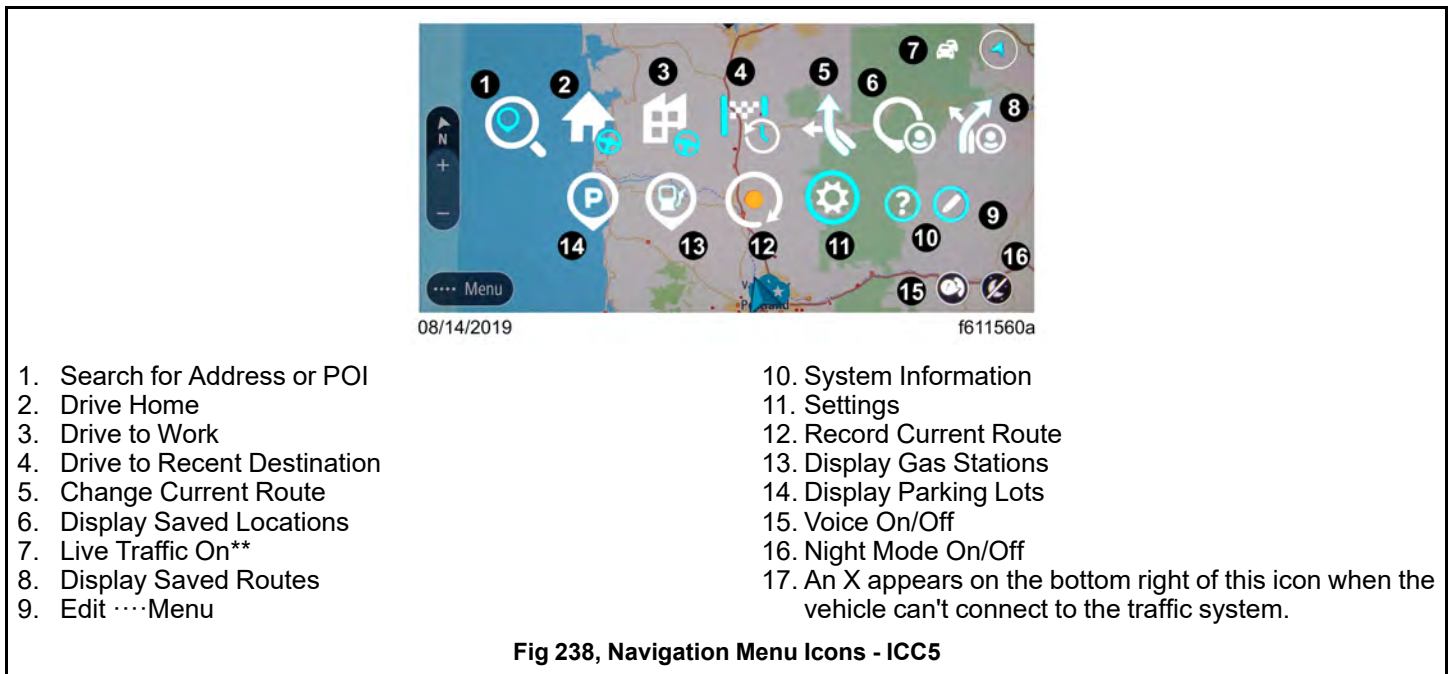

TheMenu button will bring up the first of three screen of Navigation Menu Icons. Access the Settings menu to create a vehicle profile.

Creating a Vehicle Profile

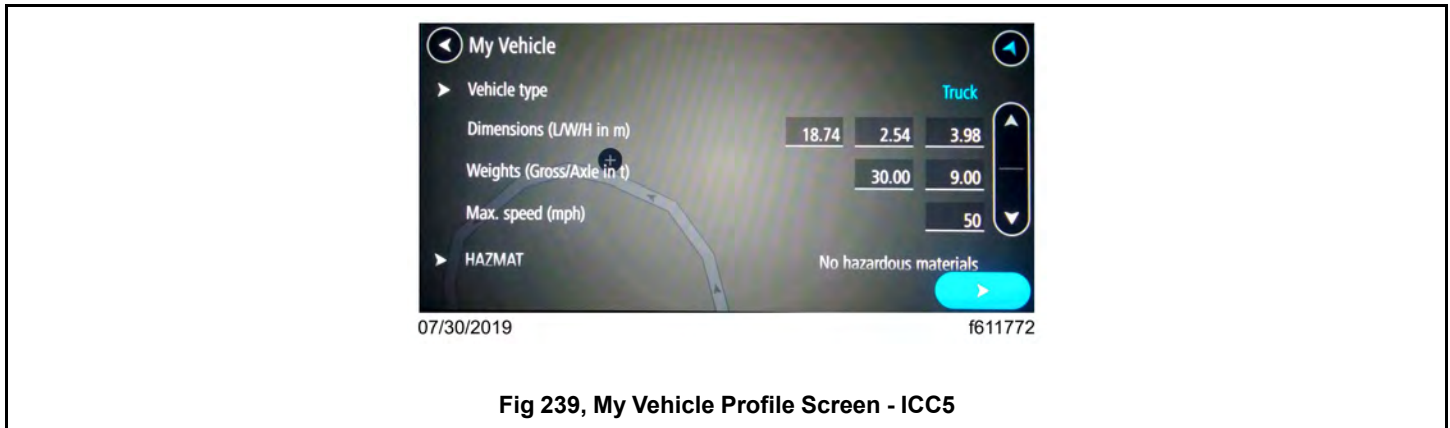

Fig 239, My Vehicle Profile Screen - ICC5

Whenever possible, the vehicle profile will be taken into account during route calculation. When a chosen destination is not reachable via a route that takes your vehicle profile into account, the system will inform you that the route is calculated based on different vehicle profile.

Depending on local conditions, the navigation system may not always be able to include all selected settings for route calculation, avoiding toll roads for example.

1. Select \cdots Menu.
2. Select Settings.
3. Select My Vehicle.
4. Select Vehicle type. A list of possible types of vehicle appears.
 - Select a vehicle type from the list then press the back arrow in the upper left corner of the screen. The current settings of the type of vehicle appears.
 - If needed, select the values and adjust them to match the actual vehicle.
 - If you are transporting hazardous materials, add these to your vehicle profile.

Adding Hazardous Dangerous Goods to the Vehicle Profile

Hazardous materials includes, in part, explosives, gases, flammable liquids, flammable solids, oxidizers and organic peroxides, toxic and infectious substances, radioactive substances, and corrosive substances.

NOTE: The value 0 equals No Hazardous Materials and causes the system not to check for route restrictions.

1. Select My Vehicle
2. Select HAZMAT. A list of possible dangerous goods settings appears.
3. Select a class or classes of hazardous material by sliding the radio button to the right. The active radio button(s) will be highlighted in color.
4. Press the back arrow next to the Setup Hazardous Materials title on the screen. Check that the appropriate hazardous material icons have appeared on the My Vehicle screen.

Adjusting the Display

Turning On Automatic Switching to Night View

NOTE: Night View can be turned on or off by pressing the Night View icon located at the bottom right of the \cdots Menu screens.

When the setting is active, the display automatically switches to night view when dark.

1. Select \cdots Menu.
2. Select Settings.
3. Select Appearance.
4. Select Display.
5. Select Switch To Night Colors When Dark. The radio button is highlighted in color when the setting is active.

Adjusting Arrival Information on the Route Bar

The driver can set the type of arrival information to display on the route bar and whether the information is displayed for the final destination or for the next intermediate destination.

1. Select \cdots Menu.
2. Select Settings.
3. Select Appearance.
4. Select Route bar.
5. Select Arrival information.
6. Select a setting; the active setting is indicated by a dot highlighted in color.

Adjusting Route Information on the Route Bar

The driver can set the route information to display on the route bar, such as gas stations, parking lots, rest areas, toll zones, and ferries.

1. Select \cdots Menu.
2. Select Settings.
3. Select Appearance.
4. Select Route bar.
5. Select Route information.
6. Select desired setting(s); active settings are highlighted in color.

Displaying the Time

When this function is active, the current time appears at the bottom of the route bar.

1. Select \cdots Menu.
2. Select Settings.
3. Select Appearance.
4. Select Route bar.
5. Select or Deselect Show Current Time. If Show Current Time is on, the option is highlighted in color.

Displaying a Wider Route Bar

NOTE: Both map and route bar views can be enlarged to show more detail or zoomed out on to show less by using a two-finger swipe.

When Show Wide Route Bar If Possible is on, a wider route bar appears. The wider route bar contains additional route information, e.g. journey time and distance from a traffic jam.

1. Select \cdots Menu.
2. Select Settings.
3. Select Appearance.

4. Select Route Bar.
5. Select Show Wide Route Bar If Possible. If Show Wide Route Bar If Possible is on, the option is highlighted in color.

Adjusting the Route View

The following settings are available for adjusting the route view:

- Display current street names: when this setting is active, the name of the road the driver is currently driving on appears on the route bar.
- Route display style: set whether the route view is displayed in 2D (in direction of travel) or 3D.
 1. Select ⋮ Menu.
 2. Select Settings.
 3. Select Appearance.
 4. Select Guidance view.
 5. Select if the current street name should be displayed. If this setting is on, the radio button will be highlighted in color.
 6. Select your guidance view style: 3D or 2D (in direction of travel). The selected mode will be highlighted in color.

Adjusting the Automatic Zoom

The following settings are available for Automatic Zoom:

- Zoom In To Next Turn. When this setting is active, all turns and intersections on the route will be zoomed in on along the route.
- Based On Road Type. When this setting is active, all turns and intersections on the route may or may not be zoomed in on, depending on the type of street.
- None. When this setting is active, turns and intersections are not zoomed in on.
 1. Select ⋮ Menu.
 2. Select Settings.
 3. Select Appearance.
 4. Select Automatic Zoom.
 5. Select a zoom option. The active setting will be highlighted in color.

Selecting a Voice for Spoken Messages

NOTE: If you choose a voice incompatible with the units of measurement selected, the system will ask you to verify your choice. In addition, certain voices may be unable to read warnings out loud, in which case the option to turn on that feature will be disabled until you select a compatible voice.

The default short voice list includes the following English and Spanish variations: New Zealand English, Irish English, Australian English, United States English, British English, Spanish, and Mexican Spanish.

The system also includes voices speaking the world's major languages outside of English and Spanish. They can be accessed by selected the All Voices button in the bottom right of the Choose a Voice screen.

1. Select ⋮ Menu.
2. Select Settings.
3. Select Voices.
4. Select Choose a voice.
5. Select a voice with the desired language and accent; the active setting is indicated by a colored dot.

Voice Instruction Settings

Two instruction settings are available under the Voices menu: Read Arrival Time Out Loud and Read Early Instructions Out Loud.

When Read Arrival Time Out Loud is active, the projected arrival time is read by the selected voice. When Read Early Instructions Out Loud is active, instructions to exit or turn are given in advance such as "Ahead, turn left," and "After one mile take the right exit."

1. Select Settings.
2. Select Voices.
3. Select Choose a voice.
4. Select if you would like either or both of the vocal instruction settings turned on; an active setting is indicated by a radio switch highlighted in color.

Setting the Route Planning Type and Method

The following settings are available under route planning type:

- Fastest Route. The navigation calculates a route with the shortest possible journey time.
- Shortest Route. The navigation calculates a route with the shortest possible distance.

The following settings are available for choosing a faster route when travel is underway:

- Always Take the Fastest Route. When a faster route is available, navigation automatically recalculates the route.
- Ask Me So That I Can Choose. When a faster route is available, navigation asks whether the faster route should be used.
- Don't Ask Me. The navigation system does not look for faster routes.
 1. Select ⋮ Menu.
 2. Select Settings.
 3. Select Route Planning.
 4. Select a route planning method; the active setting is indicated by a colored dot.
 5. Select a route planning type (fastest or shortest). The active choice is highlighted in color.

Route Options, Avoiding Areas

Avoiding Ferries, Toll Roads, Carpool Lanes, Unpaved Roads, and Tunnels

1. Select ⋮ Menu.
2. Select Settings.
3. Select Route Planning.
4. Swipe down to select the Avoid On Every Route option.
5. Select what features to avoid. The radio button is highlighted in color when a feature is selected.

NOTE: These route options are not available in every country. Also, the selected route options cannot always be taken into account. Therefore, a route may include a ferry, for instance, even though the avoid ferries option is active.

Sounds and Warnings

NOTE: Some voices are not compatible with reading warnings out loud. If this is the case with the selected voice, notification will appear on the screen and the option to have warnings read out loud will not be available until you choose a different compatible voice.

The following settings are available to choose warning types:

- Read Out Loud. When this setting is active, spoken warnings and warning sounds are issued during the journey.

- Sounds. When this setting is active, only warning sounds are issued during the journey.
- Visual Only. When this setting is active, no spoken warnings or warning sounds are issued during the journey.
 1. Select **⋮**Menu.
 2. Select Settings.
 3. Select Sounds & Warnings.
 4. Select Warning Type.
 5. Select the desired warning type; the active setting is indicated by a colored dot.

Settings for Spoken Warnings

The navigation system can issue vocal warnings about traffic jams and other traffic issues as well as say when the vehicle has exceeded the speed limit.

1. Select **⋮**Menu.
2. Select Settings.
3. Select Sounds & Warnings.
4. Swipe down to the bottom of the page. The following options are listed: Traffic Jam Ahead, When Speeding, and Read Traffic Warnings Out Loud. Move the radio button to the right for those warnings you want read aloud. An active choice will have the radio button highlighted in color.

Setting the Units

Unit settings include: Kilometers (km), miles & yards (mi/yd), miles & feet (mi/ft), and automatic.

1. Select **⋮**Menu.
2. Select Settings.
3. swipe Select Units.
4. Select the desired units; the active setting is indicated by a dot highlighted in color.

Reordering Menu Options

The top level menu options My Places, My Routes, Parking Lot, Gas Station, Report Safety Camera, Start Recording, and Settings can be reordered to move the most used options to the first screen.

Reordering the Menu

1. Swipe right until you reach the end of the icon list.
2. Select the pencil icon. Each menu item with its corresponding icon will now outlined as if they have been turned into illustrations on a playing card.
3. Select the menu item and icon you want to move. It will be highlighted in color and two arrows will appear at the bottom.
4. Press either the right or left arrow to move the card over to the left or right until it's in the desired position.
5. If desired, select and move other cards.
6. Press the Done button when finished.

8.07.05 Navigation Menu

Destination Entry

All the keyboard entries are locked when the parking brake is disengaged.

Enter a destination into the navigation system using the following options:

- Enter a named location.

- Enter a street address on the search line at the top of the map.
- Enter the longitude and latitude.
- Enter map codes.
- Zoom in on the map to find the desired location and press and hold to select.

NOTE: Results matching the characters entered using the keyboard will appear on the address results list and the Point of Interest (POI) categories or POI results list.

Selecting a Destination From the Address

NOTE: The farther away the destination is from the current vehicle position, the longer it will take for the route to be calculated.

1. Open the navigation system.
2. Tap next to the magnifying glass Search icon.
3. Enter the desired address, see Fig.240, [Entering a Destination - ICC5](#).

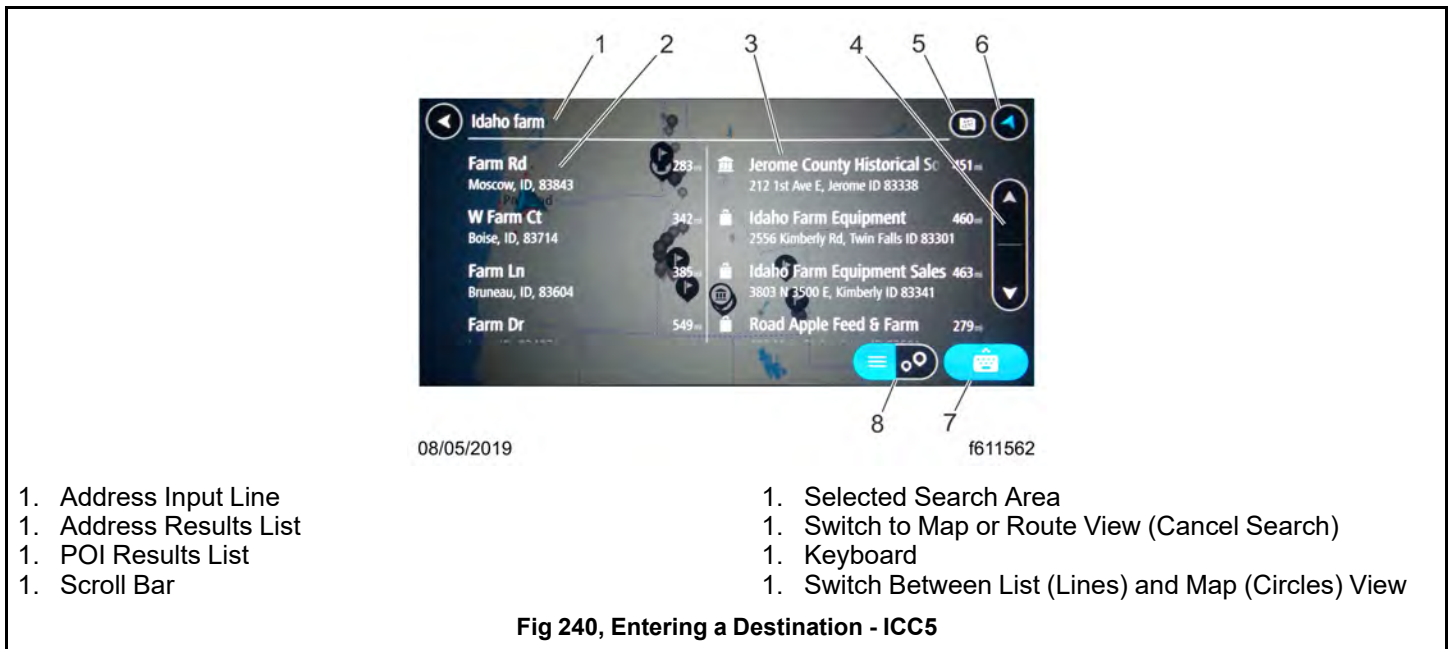
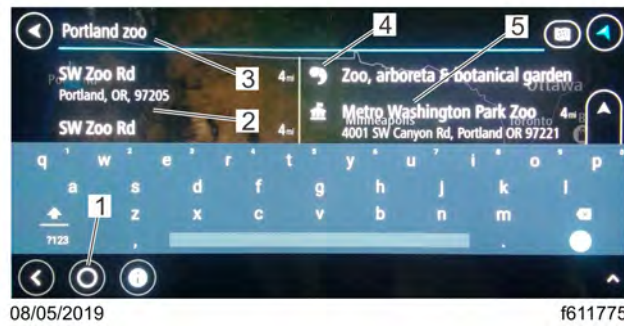

Fig 240, Entering a Destination - ICC5

4. Select the desired location from the results lists.
5. Select Drive.
6. The My Vehicle type and configuration screen appears; verify the information by selecting the arrow at the bottom right. If necessary, update the information and then select the arrow at the bottom right to verify it.
7. Select Let's Go... to start navigation guidance.

Selecting a Destination From Points of Interest (POI)

1. Select ...Menu.
2. Select Search option for input menu.
3. Enter a saved POI such as Home or a type of POI such as Gas Station or Zoo.



- | | |
|-----------------------|----------------------|
| 1. Map View | 4. POI Category List |
| 2. Address Results | 5. POI List |
| 3. Address Input Line | |

Fig 241, POI Results Lists - ICC5

4. Select POI or a POI type from the results list; the destination appears.
5. Select Drive.
6. The My Vehicle type and configuration screen appears; verify the information by selecting the arrow at the bottom right. If necessary, update the information and then select the arrow at the bottom right to verify it.
7. Select Let's Go... to start navigation guidance.

Selecting a Destination From the Recent Destinations

1. Select ...Menu.
2. Select Recent Destinations to display a list of previous destinations.
3. Select a destination from the list.
4. Select Drive.
5. The My Vehicle type and configuration screen appears; verify the information by selecting the arrow at the bottom right. If necessary, update the information and then select the arrow at the bottom right to verify it.
6. Select Let's Go... to start navigation guidance.

Selecting a Destination on the Map

1. Open the navigation system.
2. Search for a destination on the map by swiping and zooming.
3. Select the destination on the map by pressing and holding. The address nearest to the selected point appears.
4. Select Drive.
5. The My Vehicle type and configuration screen appears; verify the information by selecting the arrow at the bottom right. If necessary, update the information and then select the arrow at the bottom right to verify it.
6. Select Let's Go... to start navigation guidance.

Selecting a Destination from Geo-Coordinates

1. Open the navigation system.
2. Either select the search bar at the top of the map or select the Search option under ...Menu.
3. Select the button to the right of the search input line to define the search area.
4. Select Latitude Longitude. An input menu appears.
5. Enter the geo-coordinates. The results appear in the results list.

6. Select a destination from the results list; a menu appears.
7. Select Drive.
8. The My Vehicle type and configuration screen appears; verify the information by selecting the arrow at the bottom right. If necessary, update the information and then select the arrow at the bottom right to verify it.
9. Select Let's Go... to start navigation guidance.

Selecting a Destination from a Map Code

1. Open the navigation system.
2. Select the search bar at the top of the map. Make sure the correct search area is defined for your map code.
3. Enter a map code; the results are displayed in the results list.
4. Select a destination from the results list; a menu appears.
5. Select Drive.
6. The My Vehicle type and configuration screen appears; verify the information by selecting the arrow at the bottom right. If necessary, update the information and then select the arrow at the bottom right to verify it.
7. Select Let's Go... to start navigation guidance.

The following are the examples of map code entries:

- Edinburgh Castle, international map code - WH6SL. TR10
- Edinburgh Castle, country specific map code - GBR 8MH.51
- The Field Museum of Natural History, country specific map code - T821.1BFF
- The Field Museum of Natural History, state specific map code - WM.GO (Must have Illinois selected as search area for this code to resolve correctly.)
- The Field Museum of Natural History, alternatives - SY.FRQ or 9Q9.VOP

Selecting a Destination from Saved Destinations

1. Select ...Menu.
2. Select My Places a list of saved destinations appears.
3. Select a destination from the list; the destination appears on the map.
4. Select Drive.
5. The My Vehicle type and configuration screen appears; verify the information by selecting the arrow at the bottom right. If necessary, update the information and then select the arrow at the bottom right to verify it.
6. Select Let's Go... to start route guidance.

Selecting a Destination from Saved Routes

1. Select ...Menu.
2. Select My Routes. If you have saved routes, a list of saved routes appears.
3. Select a route from the list.
4. The My Vehicle type and configuration screen appears; verify the information by selecting the arrow at the bottom right. If necessary, update the information and then select the arrow at the bottom right to verify it.
5. The route appears on the map. Select Drive to calculate the route.
6. Select Let's Go... to start navigation guidance.

Searching for a Parking Lot Area

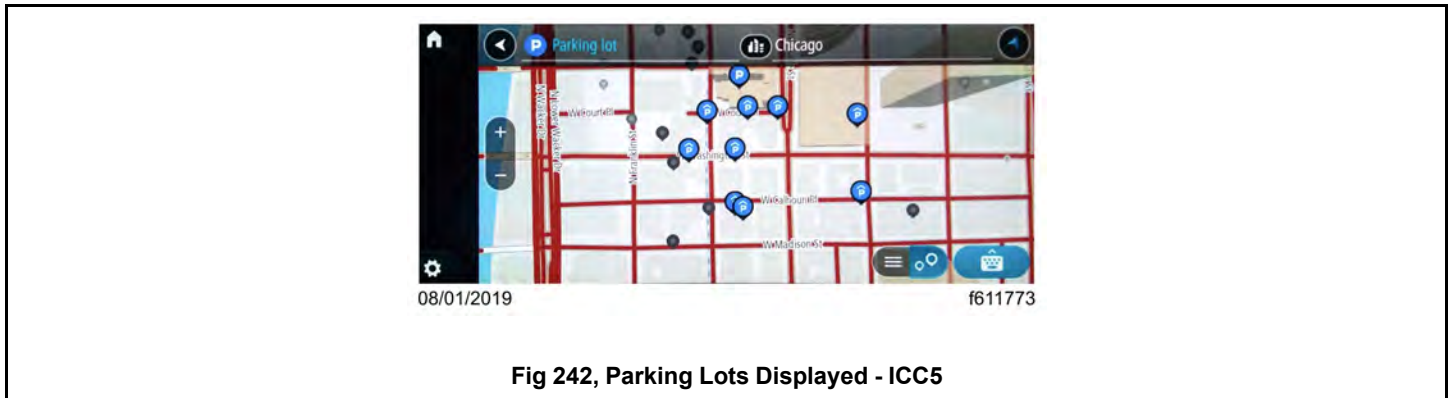

Fig 242, Parking Lots Displayed - ICC5

NOTE: Navigation shows gas stations, parking lots, and other locations that may not be suitable for your vehicle's size and weight. Use caution when selecting locations and routes.

1. Select ⋮ Menu.
2. Select Parking Lot.
 - 2.a If a route is active, the map appears with parking lots near the destination.
 - 2.b If a route is not active, the map appears with parking lots near the current vehicle location.
3. Select a parking lot area; the name of the parking lot area appears on the map.
4. Select Drive to recalculate the route to end at the chosen parking lot; the route to the destination appears.
5. The My Vehicle type and configuration screen appears; verify the information by selecting the arrow at the bottom right. If necessary, update the information and then select the arrow at the bottom right to verify it.
6. Select Let's Go ⋮ to start the navigation guidance.

Searching for Gas Stations

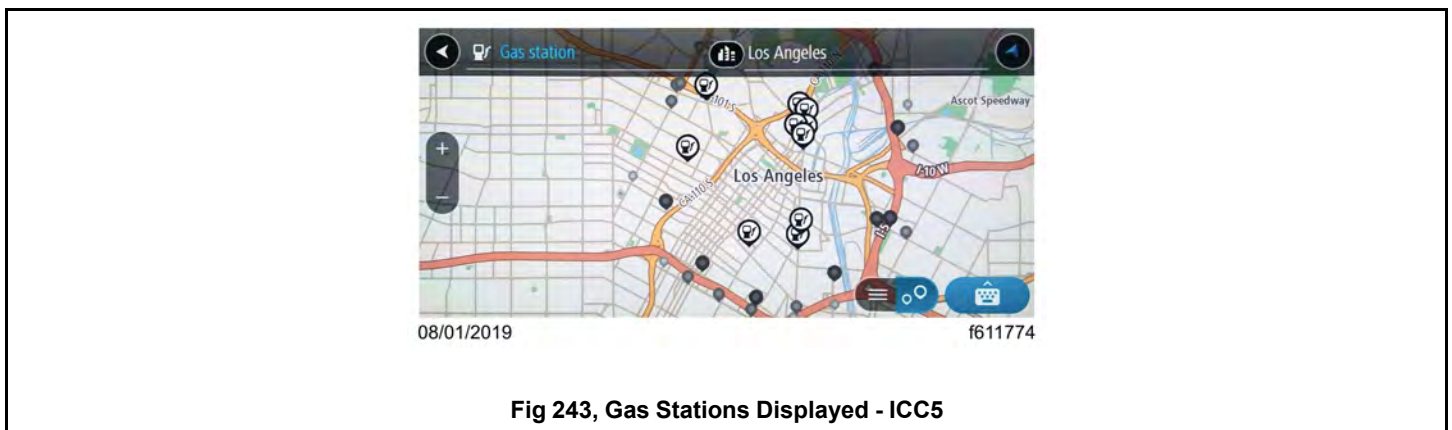

Fig 243, Gas Stations Displayed - ICC5

NOTE: Navigation shows gas stations, parking lots, and other locations that may not be suitable for your vehicle's size and weight. Use caution when selecting locations and routes.

1. Select ⋮ Menu.

2. Select Gas station.
 - 2.a When the route is active, the map appears with gas stations along the route.
 - 2.b When the route is not active, gas stations appear on the map near the current vehicle location.
3. Select a gas station; the name of the gas station appears on the map.
4. Select Drive.
5. The My Vehicle type and configuration screen appears; verify the information by selecting the arrow at the bottom right. If necessary, update the information and then select the arrow at the bottom right to verify it.
6. Select Let's Go to start the navigation guidance.

8.07.06 Saving a Destination

My Places

In addition to saved destinations, My Places contains the following information:

- Home
- Recent destinations
- Work
- Marked locations

Saving a Destination Under My Places

1. Select Menu.
2. Select My Places.
3. Select Add.
4. Select a destination on the map or select Search and put in an address.
5. Select from the results list; the destination appears on the map.
6. Select Add to My Places to save the destination.
7. Give the destination a unique name or keep it as an address. Select the blue check mark to save the destination.
8. The destination is saved under My Places and marked with a star on the map.

Saving an Address as Home

NOTE: Saving a second location and calling it Home will replace the original Home location with the second location address.

1. Select Menu.
2. Select My Places.
3. Select Add Home if no home address has been saved; if a home address has been saved, follow the directions above for Saving a Destination Under My Places to add a second home address. In either case, the map with the search bar appears.
4. Select home on the map or select Search and enter an address.
5. Select Set if choosing a point on the map; select from the results list if an address was entered then select Set Home Location.
6. The home appears on the map and is saved as Home.

Saving an Address as a Workplace

NOTE: Saving a second location and calling it Work will replace the original work location with the second location address.

1. Select ⋮ Menu.
2. Select My Places.
3. Select Add Work. The map appears.
4. Select the workplace on the map or select Search and enter an address.
5. Select Set if choosing a point on the map; select from the results list if an address was entered, then select Set Work Location.
6. The workplace appears on the map and is saved as Work.

8.07.07 Deleting a Destination

Deleting a Destination from the List of Recent Destinations

1. Select ⋮ Menu.
2. Select My Places.
3. Select Recent Destinations.
4. Select Edit List.
5. Select a destination; a minus sign appears next to the destination.
6. Select Delete. The destination is deleted from the list of recent destinations.

NOTE: You can delete multiple destinations at the same time.

8.07.08 Planning a Route

Specifying a Starting Point

NOTE: For accurate results when selecting an address from the map, zoom in.

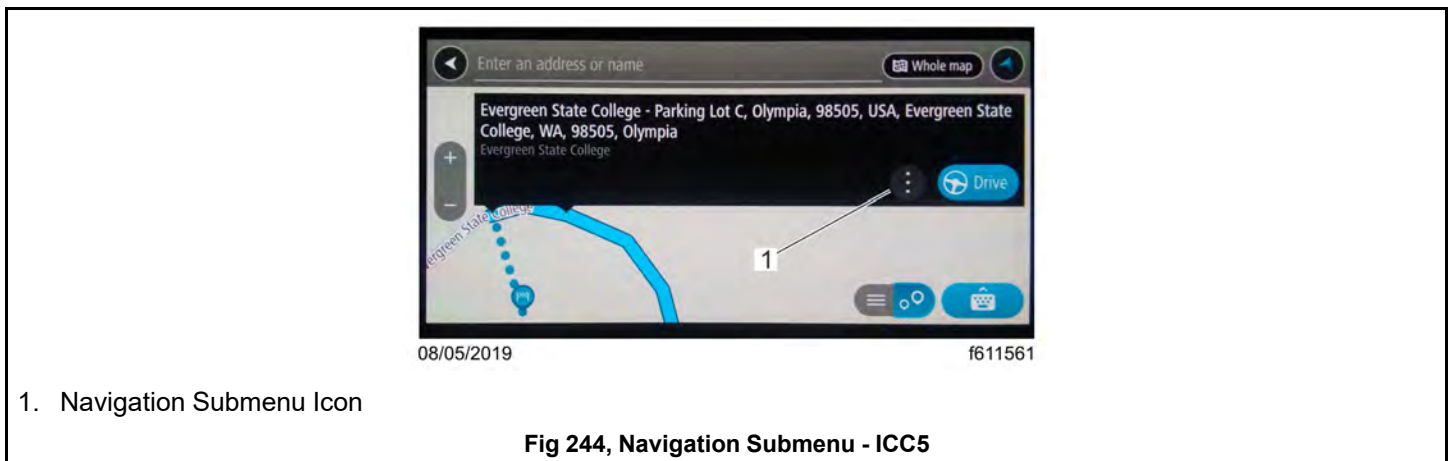

1. Open the navigation system.
2. Press and hold a fingertip on an area of the map, or enter an address and select from the results lists.
3. Select the circle with the three vertical dots next to the address name to access the submenu.

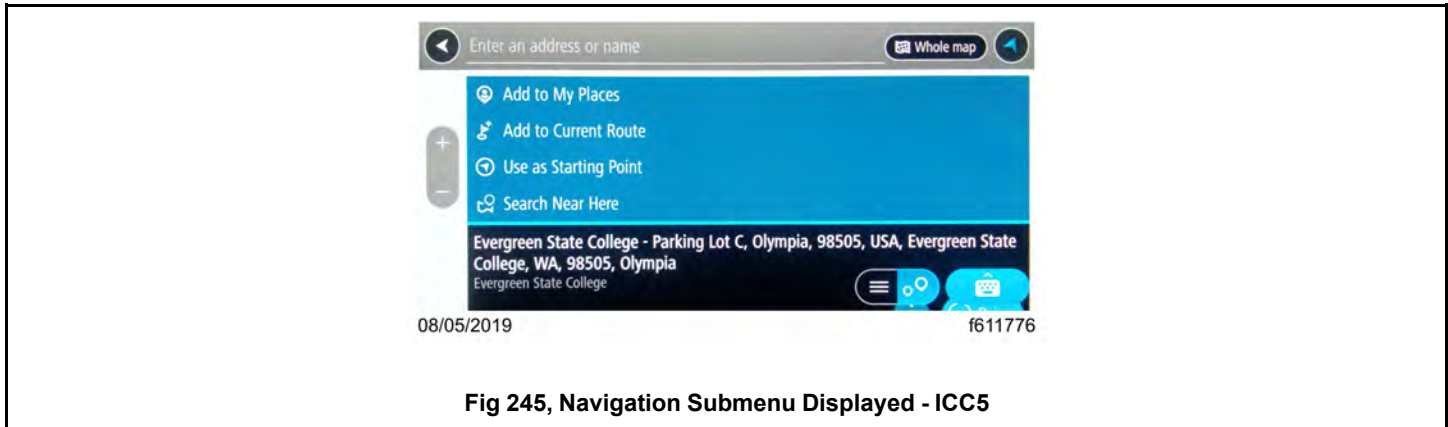

Fig 245, Navigation Submenu Displayed - ICC5

4. Select Use as a Starting Point. The location appears on the map.

Specifying a Destination

1. Open the navigation system.
2. Press and hold a fingertip on an area of the map, or enter an address and select from the results lists.
3. Select Drive.
4. The My Vehicle type and configuration screen appears; verify the information by selecting the arrow at the bottom right. If necessary, update the information and then select the arrow at the bottom right to verify it.
5. The route is calculated and appears on the map.
6. Select Let's Go... to start the navigation guidance.

Select the Current Position as the Starting Point in the Middle of a Route

1. Select the starting point of the route.
2. Select the circle with the three vertical dots next to the address name to access the submenu.
3. Select Remove Starting Point. The route is recalculated with the current vehicle position as the starting point.

Specify an Intermediate Destination Using the Route Map

NOTE: Add to Current Route adds an address to the route. Search Near Here accesses the point of interest (POI) menu.

1. Create a route map to the final destination.
2. Zoom in on that part of the route that contains the intermediate destination.
3. Press and hold a fingertip on the intermediate destination on the map.
4. An address will appear. Select the circle with three vertical dots to access the submenu. Choose Add to Current Route or continue searching by choosing Search Near Here.
 - 4.a Choose the icon for a POI (a meal, a gas station) and select from the list of options.
 - 4.b The address appears. Select the circle with the three vertical dots next to the address name to access the submenu and add the location to the route
5. When all intermediate destinations are added to the route, select Drive. The route is calculated.
6. Select Let's Go...

8.07.09 Saving a Route

Saving the Current Route

1. Select ... or ...Menu.

2. Select Current Route.
3. Select Add to My Routes. An input menu appears.
4. Change the name of the route if desired.
5. Select the blue checkmark to save the route; the route is saved under My Routes.

Saving Changes to a Route

Options under Current Route include Skip Next Stop, Find Alternative, Avoid Blocked Road, Avoid Toll Roads and More, Show Instructions, Add Stop to Route, Add to My Routes and Change Route Type.

1. Create a route.
2. Select \cdots or \cdots Menu.
3. Select Current Route.
4. Select the desired type of change to the route.

Deleting Intermediate Destinations

1. Select the route map view. Zoom in on the intermediate destination to be deleted.
2. Select the intermediate destination to be deleted.
3. Select the circle with the three vertical dots next to the address name to access the submenu.
4. Select Delete This Stop. The route is recalculated without the intermediate destination.

Deleting a Saved Route

1. Select \cdots or \cdots Menu.
2. Select My Routes. The list of saved routes appears.
3. Select Edit List.
4. Select a route; a minus sign appears next to the route.
5. Select Delete the route is deleted.

NOTE: you can delete more than one saved route at a time.

8.07.10 Current Route

Cancelling the Active Route

NOTE: To exit the active route screen, select the arrow with the line through it.

1. Select \cdots or \cdots Menu.
2. Select Current Route.
3. Select Clear Route. The active route is deleted and the map view appears.

Changing the Route Options

[Changing the Order of Intermediate Destinations](#)

1. Open the saved route with intermediate destinations.
2. Select \cdots or \cdots Menu.
3. Select Current Route.
4. Select Reorder Stops; the starting point, destination and all intermediate destinations appear on the map.

5. Select the starting point.
6. Select the intermediate destinations one by one in the desired order; flags appear at the intermediate destinations.
7. Select the destination last; the new route is calculated.

Displaying Alternative Routes

1. Create a route.
2. Select \cdots , or \cdots Menu.
3. Select Current Route.
4. Select Find Alternative. A maximum of three alternative routes appear on the map. The difference between the driving time or distance compared to the original route is displayed for each route.
5. Select an alternative route by selecting the route shown on the map or selecting the icon displaying the difference in driving time or distance.
6. Select Let's Go \cdots to start navigation guidance. The route view appears.

Avoiding Closed Roads

1. Create a route.
2. Select \cdots , for \cdots Menu.
3. Select Current Route.
4. Select Avoid Blocked Road. If an alternative route excluding the closed road is available, the alternative route appears on the map. The difference between the driving time or distance compared to the original route is displayed for the route.
5. To select the alternative route select the route shown on the map or select the icon displaying the difference in driving time or distance.
6. Select Let's Go \cdots to start route guidance. The route view appears.

Displaying Navigation Instructions

1. Create a route.
2. Select \cdots , or \cdots Menu.
3. Select Current Route.
4. Select Show Instructions. A list of directions is shown starting with the current location.

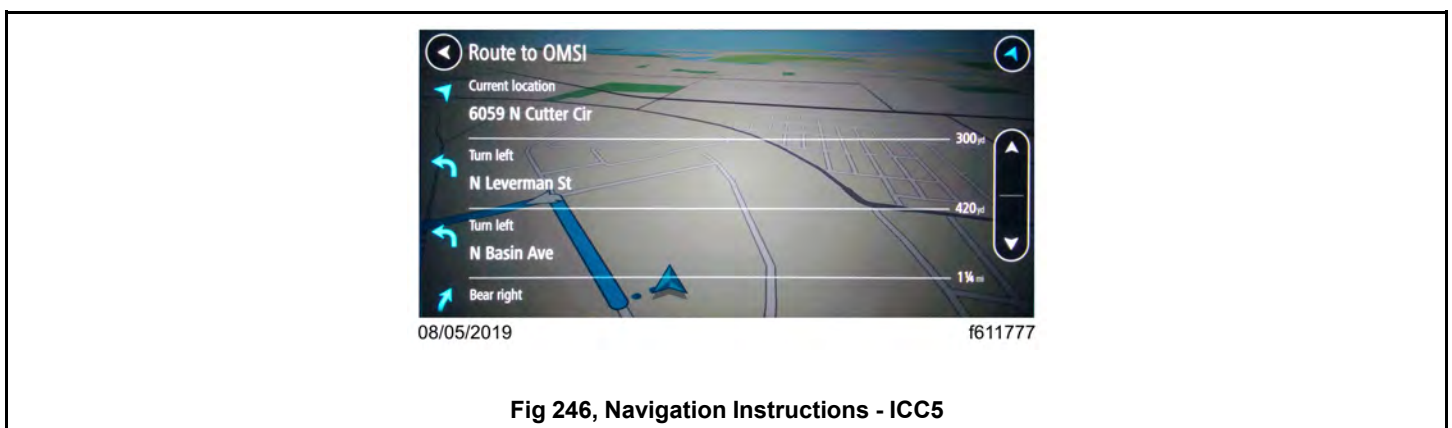

Fig 246, Navigation Instructions - ICC5

The current vehicle position is shown with the following information:

- The symbol for the current vehicle position is displayed.

- The name of the road you are currently driving on is displayed.
- The road number of the road you are currently driving on is displayed.

Driving to the Starting Point of a Route

The driver can use this function to drive from the current vehicle position to the starting point of a saved route. The starting point is changed to an intermediate destination.

1. Select **⋮**, for **⋮**Menu.
2. Select **Current Route**.
3. Select **Drive to Route**.
4. Select **Let's Go** Route navigation begins.

Current Route

Changing the Route Planning Type.

Route types consist of Fastest and Shortest.

1. Create or open a route.
2. Select **⋮**, for **⋮**Menu.
3. Select **Current Route**.
4. Select **Change Route Type**.
5. Select a route type: fastest route or shortest route. The route is recalculated with the selected route type.

Avoiding Toll Roads and More Along the Current Route

NOTE: If there are no toll roads or other features (unpaved roads, carpool lanes) along the calculated route, these options will not be available to be selected.

1. Create or open a route.
2. Select **⋮**, for **⋮**Menu.
3. Select **Current Route**.
4. Select **Avoid Toll Roads and More**. The menu of features to avoid opens.
5. Select an option or options to avoid. Then select **OK**. The main navigation screen will load.

8.07.11 During Route Guidance

Route Restrictions

When the vehicle type is set to **Bus** or **Truck** in the vehicle profile, route restrictions will be displayed in the route view during the journey. Streets with restricted access are marked in color on the route view. Streets with restricted access on the route appear as a dotted line on the map.

NOTE: Observe all the traffic signs at all times. Pay particular attention to signs with restrictions that refer to the dimensions and weight of the vehicle.

Route Overview

When a route has been calculated, the complete route appears on the map.

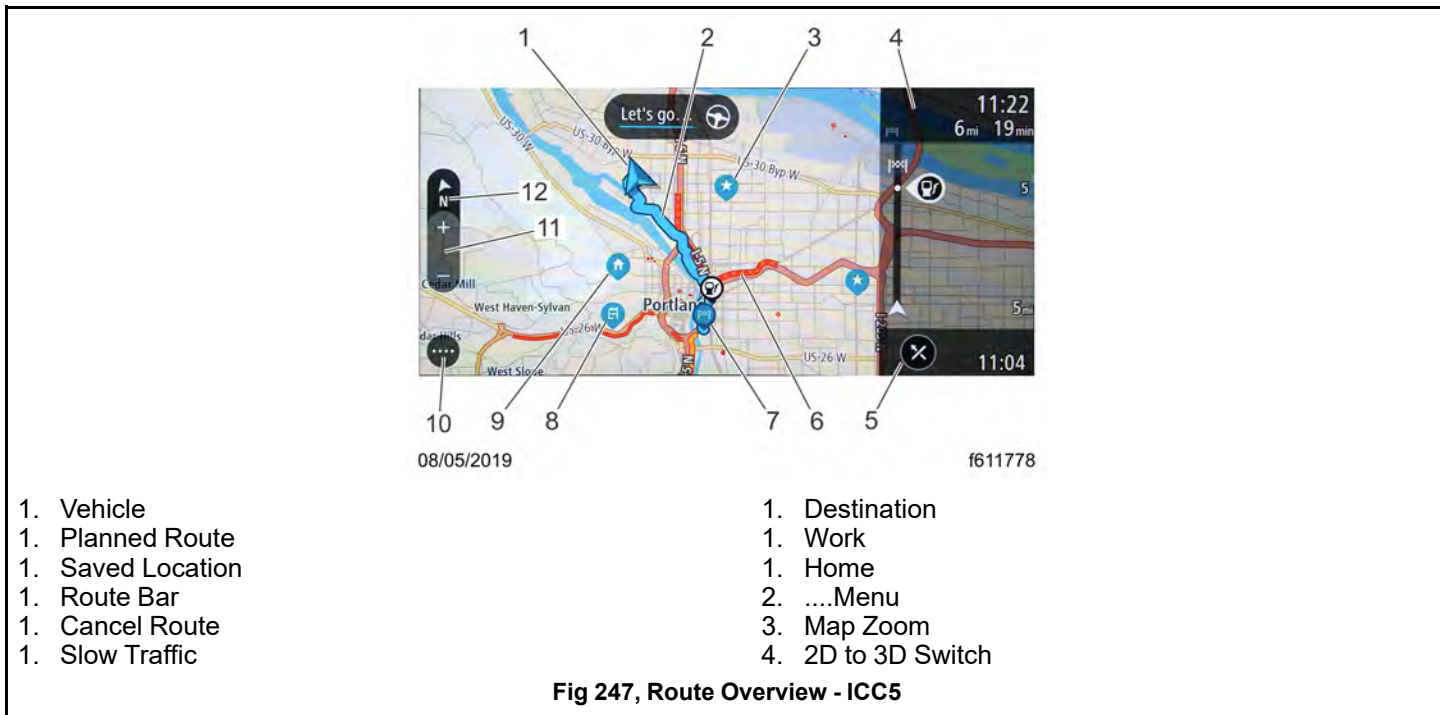

- 1. Vehicle
- 1. Planned Route
- 1. Saved Location
- 1. Route Bar
- 1. Cancel Route
- 1. Slow Traffic

- 1. Destination
- 1. Work
- 1. Home
- 2.Menu
- 3. Map Zoom
- 4. 2D to 3D Switch

Fig 247, Route Overview - ICC5

Overview of the Complete Route and Route Bar

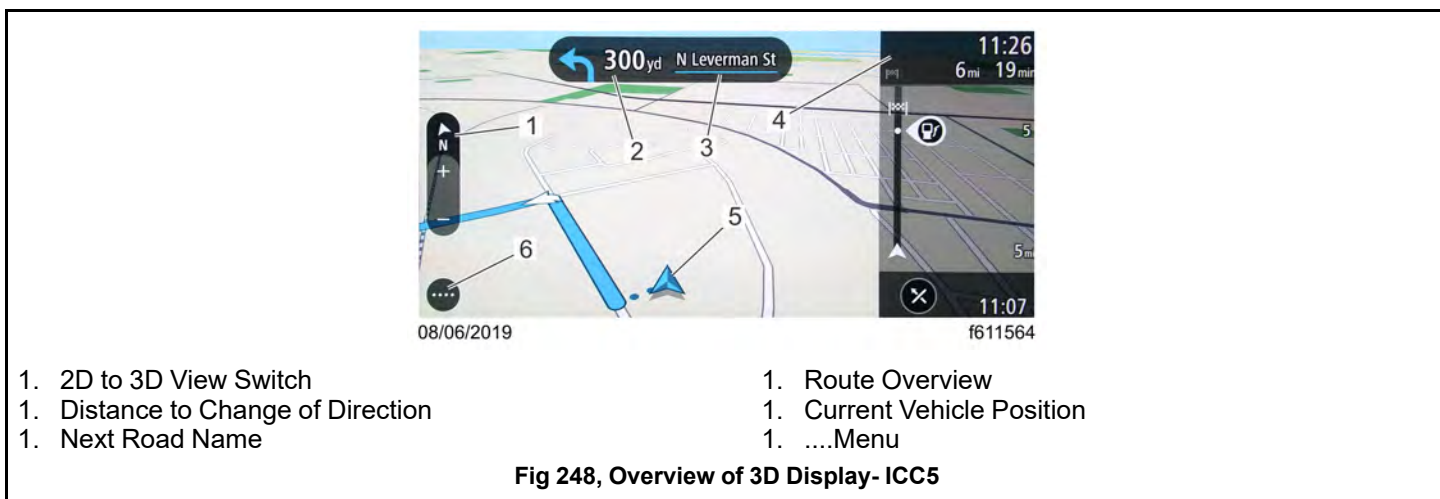

- 1. 2D to 3D View Switch
- 1. Distance to Change of Direction
- 1. Next Road Name

- 1. Route Overview
- 1. Current Vehicle Position
- 1.Menu

Fig 248, Overview of 3D Display- ICC5

When the vehicle is moving, the 3D display will show the vehicle's speed and the name of the road the vehicle is currently on at the bottom of the screen.

Touching the vehicle icon will bring up a menu that allows for reporting of a blocked road or a safety camera.

The wide progress bar shows a simplified view of the vehicle's current location on the route.

The progress bar can also show intermediate destinations and traffic messages on the route. Only the next 31 miles (50 km) will be displayed. For stretches longer than 31 miles (50 km), the progress bar can be moved by swiping up or down.

The progress bar can be zoomed in on by selecting any of the route features, e.g. gas stations, traffic delays.



Overview of Lane Recommendations

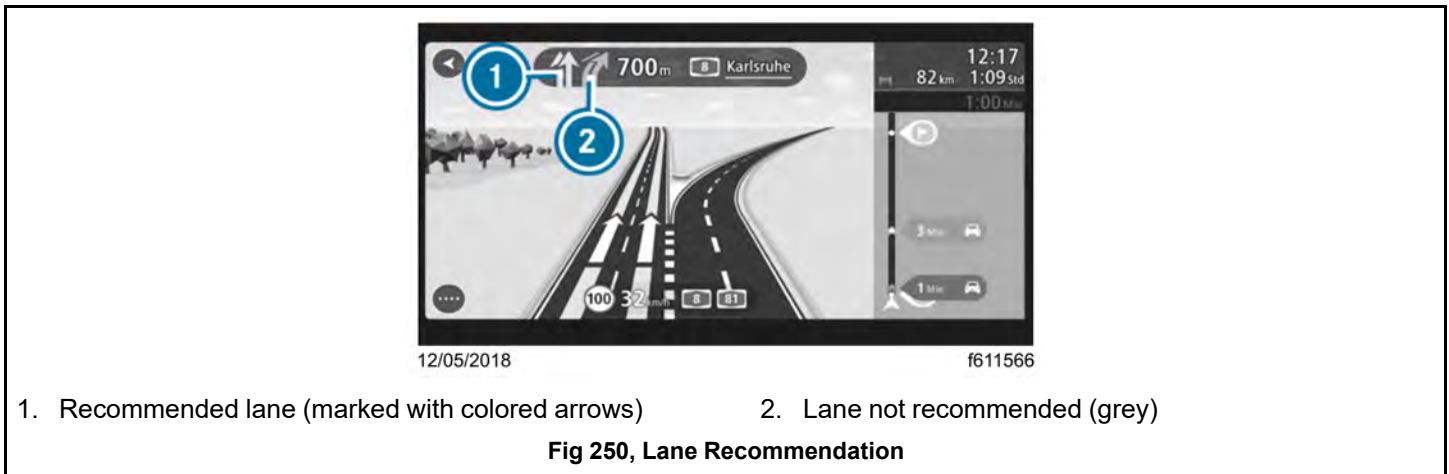

If the digital map contains the corresponding data, lane recommendations for upcoming changes of direction can be displayed before freeway exits and intersections.

Quick-Access

With quick access, you can mark the location, avoid closed roads or display the current vehicle position and the longitude and latitude. To open the quick access menu, select the symbol for the current vehicle position or the speed display.

8.07.12 Traffic

Live Traffic Information

Live Traffic Information is a subscription service which shows real-time traffic information. This service is available free of charge for three years upon activation of Live Traffic Information. Subsequently, the service may be extended for a fee.

Live Traffic Information is not available in all countries or regions. Further information can be found, see TomTom Traffic North America.

Activating Live Traffic Information

When first starting the navigation system, a popup window will appear asking if Live Traffic Information should be turned on. As soon as it is turned on the traffic situation will be shown on the Navigation Map and will be taken into account when the navigation system is asked to calculate a route.

Showing Traffic Information on the Map

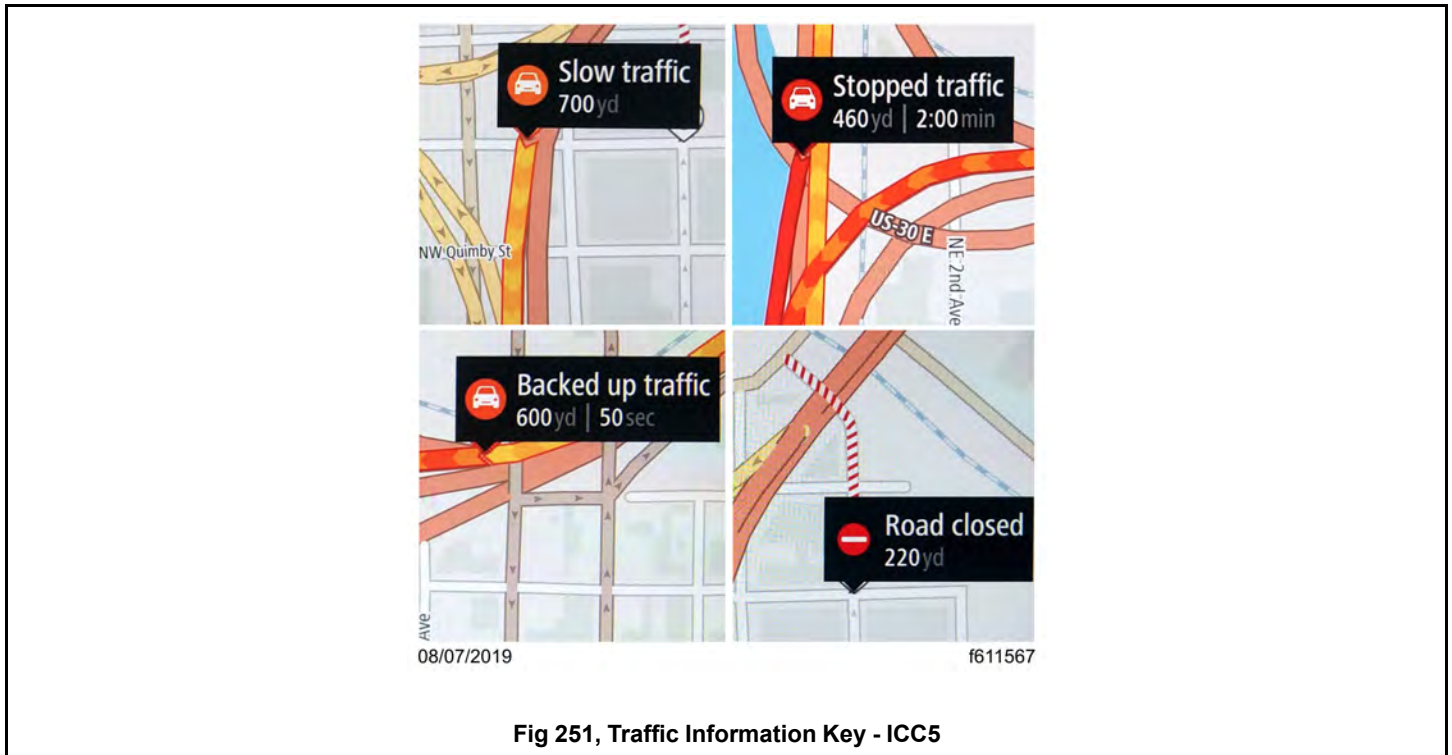

Fig 251, Traffic Information Key - ICC5

NOTE: The traffic disruption symbols display the type of traffic disruption, length, and delay in minutes. The colors display the speed of the traffic in relation to the speed limit. Red indicates stopped traffic, a mix of red and orange indicates backed-up traffic, and mix of yellow and orange indicates slow traffic. Red and white indicates a closed road.

Displaying Information About a Traffic Disruption

Select the traffic disruption on the map or route bar.

The following information about the traffic disruption is displayed:

- Type of traffic disruption, e.g. accident
- Severity of the traffic disruption: slow, heavily congested or stopped traffic
- Length of the traffic disruption
- Duration of delay

The system will also give the option of Avoid to recalculate the route to avoid the delay.

1. Select Avoid. An alternative route is calculated.
2. Select the new route on the map on by selecting the button showing the change in distance or time.
3. The route on the map and the bar update. Let's Go... appears.

8.08 AutoVue® Lane Departure Warning System

8.08.01 Overview

NOTE: The Bendix AutoVue LDW system option became available in June 2021.

AutoVue is a camera-based warning system that helps a driver avoid unintentional lane departure.

A camera mounted near the top center of the vehicle windshield tracks visible lane markings to monitor the vehicle's position within the lane. When the vehicle crosses lane markings without the turn signal being activated, AutoVue gives an audible warning.



WARNING:

The AutoVue Lane Departure Warning (LDW) system is intended only as an aid for a conscientious and alert driver. It may not warn of unintended lane departures under certain conditions. It does not warn of all possible hazards. Do not rely solely on the system to safely operate the vehicle.

The system cannot help prevent an accident if the driver is impaired or not driving safely.

Ultimate responsibility for the safe operation of the vehicle remains with the driver at all times.

8.08.02 System Startup

NOTE: The Bendix AutoVue LDW system option became available in June 2021.

AutoVue activates when the ignition is turned on. Lane departure warnings are active only when the vehicle is traveling at or above 37 mph (60 kph).

At start-up the system performs a self-test. It then plays a brief clip of the "rumble strip" alert sound, first through the left speaker, then the right. The amber 'enabled' lamp on the 'LDW OFF' switch and the lane searching dash indicator then illuminate. See Fig.252, [AutoVue LDW OFF Switch](#) and Fig.253, [AutoVue Lane Searching Dash Indicator](#).

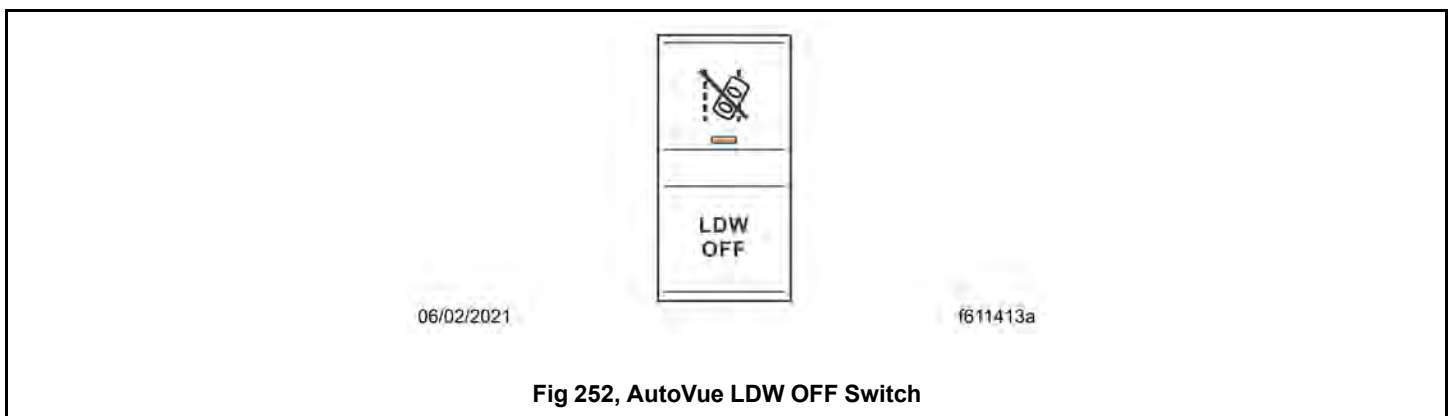

Fig 252, AutoVue LDW OFF Switch

The amber 'enabled' lamp on the LDW switch will go OFF under the following conditions:

- the driver temporarily disables the system;
- an active diagnostic trouble code (DTC) is present.



Fig 253, AutoVue Lane Searching Dash Indicator

The lane searching dash indicator will remain ON under the following conditions:

- vehicle speed is below 37 mph (60 kph);
- an active diagnostic trouble code (DTC) is present.



WARNING:

If the system cannot discover right or left lane markings, the AutoVue Lane Departure Warning system may not deliver expected alerts or erroneous alerts may occur.

Missed and false alerts may occur in the following situations:

- Lane markings are difficult to distinguish due to standing water, snow, ice, mud, sand, dirt, or other debris on the road.
- Lane markings are hidden or obscured by heavy rain, fog, falling snow or sleet, or blowing smoke.
- Lane markings are missing or faded.
- Sun glare or other light sources blind the camera, obscuring lane markings or making other road markings (e.g. tar strips) look like lane markings.
- The camera's view through the windshield glass is blocked or obscured by dirt, chips, cracks, or some other distortion.
- The camera is mis-installed.
- Headlights are not operating or are mis-aligned.

It is always the responsibility of the driver to remain vigilant and change driving practices to suit traffic and road conditions.

8.08.03 Intentional Lane Changes

NOTE: The Bendix AutoVue LDW system option became available in June 2021.

At or above 37 mph (60 kph), the AutoVue LDW system tracks both solid and dashed shoulder lines, center lines, and the lines between lanes. For a representation of the camera's field of view, see Fig.254, [Camera Field of View](#).

The system identifies intentional lane changes by monitoring the turn signal. When a lane change is made with the turn signal on, no warnings are made.

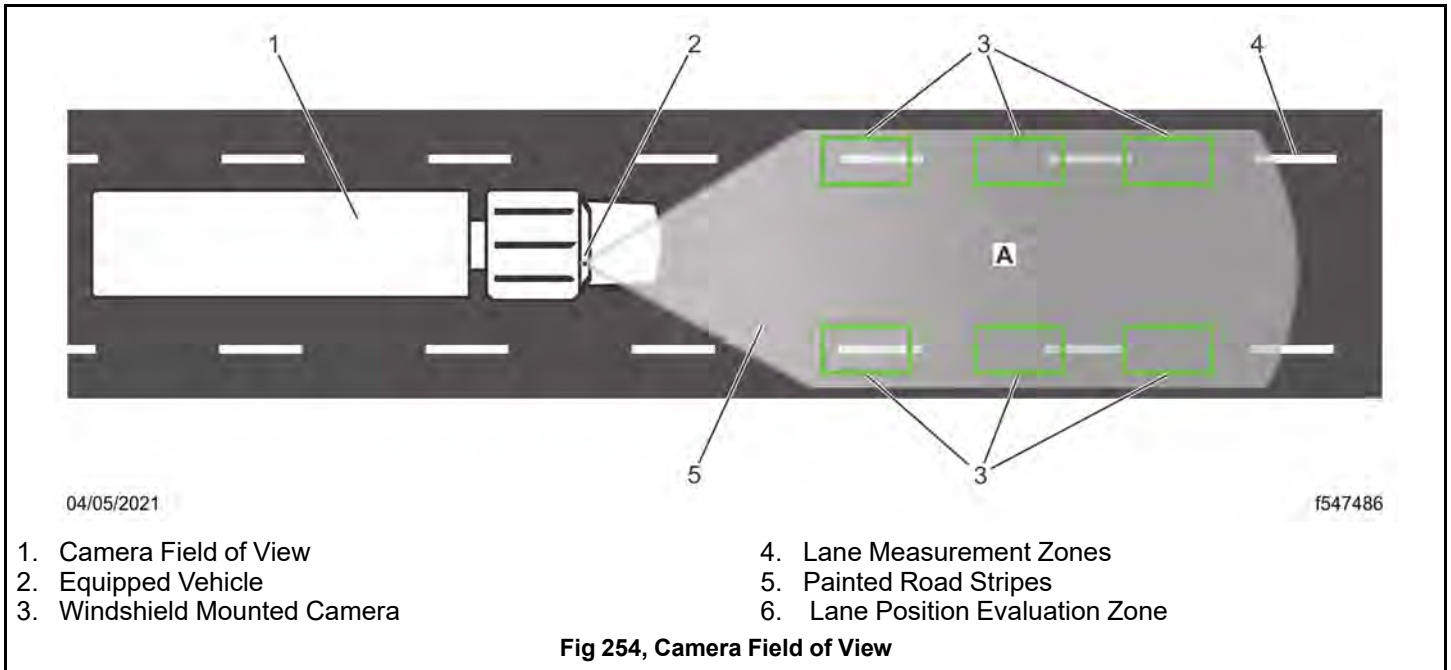

8.08.04 Unintentional Lane Departure

NOTE: The Bendix AutoVue LDW system option became available in June 2021.

When a lane change takes place without the turn signal being activated, the system alerts the driver to make a correction. The alert will come from the side of the vehicle crossing the lane markings.

8.08.05 Alert Warnings

NOTE: The Bendix AutoVue LDW system option became available in June 2021.

The AutoVue LDW system uses speakers that emit a distinctive "rumble strip" sound on the appropriate side of the cab to alert a driver of an unintentional lane departure. Audible alert volume levels are set at the factory and cannot be adjusted.

8.08.06 SafetyDirect

NOTE: The Bendix AutoVue LDW system option became available in June 2021.

When triggered by a truck safety event, the AutoVue LDW system records ten seconds of video and transmits it to the SafetyDirect portal. Fleet managers can use the video along with vehicle sensor information to enhance driver training and road safety.

8.08.07 Cleaning the Windshield in the Area of the Camera

NOTE: The Bendix AutoVue LDW system option became available in June 2021.

Make sure that the windshield is always kept clean and unobstructed in the area of the camera.

The driver should switch on the windshield wiper to clean the windshield and remove snow and ice to avoid incorrect lane detection.

If this area of the windshield is damaged, the AutoVue LDW system may not work as intended. If this happens, the windshield must be replaced.

8.08.08 Temporarily Disabling the System

NOTE: The Bendix AutoVue LDW system option became available in June 2021.

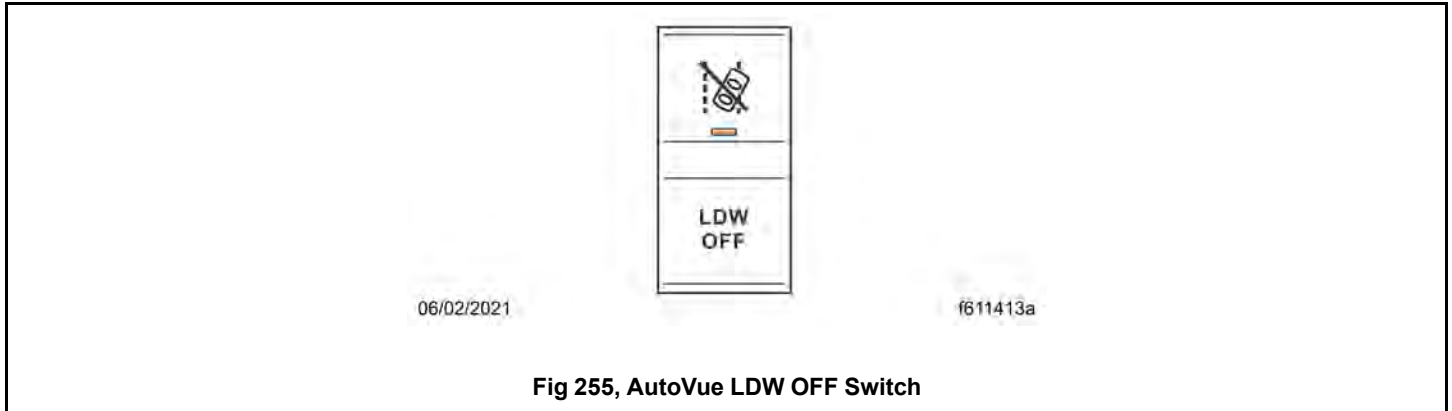

The system can be temporarily disabled by pressing the LDW OFF switch; when the system is disabled, the ambered 'enabled' lamp will go OFF. See Fig.255, [AutoVue LDW OFF Switch](#). The system will re-enable itself after 15 minutes. Warnings can be enabled sooner by pressing the switch again.

8.08.09 System Offline Indicators

NOTE: The Bendix AutoVue LDW system option became available in June 2021.

If the AutoVue LDW system goes offline while vehicle speed is at or above 37 mph (60 kph), the lane searching dash indicator will appear and the amber light in the LDW OFF switch will go out. Conditions that may cause this include:

- undetectable lane markings;
- an obscured camera lens;
- a system diagnostic trouble code (DTC).

If the lane searching dash indicator stays ON for a long period of time with the vehicle speed at or above 37 mph (60 kph) and the amber enabled lamp on the LDW OFF switch remains ON despite depressing the switch, the system requires calibration services at an authorised dealer.

8.09 OnGuardACTIVE™ Collision Mitigation System

8.09.01 General Information

WABCO OnGuardACTIVE CMS is a forward-looking radar-based safety system. The system includes forward collision warning, adaptive cruise control (ACC), and collision mitigation.

OnGuard equipped vehicles have antilock brakes (ABS) and automatic traction control (ATC), and either roll stability control (RSC) or electronic stability control (ESC). These systems work together to enhance control of the vehicle. Depending on the situation, any of these features may apply throttle control, engine brakes, and/or service brakes, as needed.

The front-looking antenna assembly transmits radar signals to, and receives them back from, objects ahead of the vehicle. To be detected, vehicles must be within the radar field of view and provide a surface area that can reflect the radar. The distance, speed, and angle of the vehicle ahead is calculated, and the driver is warned of potentially dangerous situations. The system also warns of stationary objects to alert the driver of potential obstructions ahead in their lane.

**WARNING:**

The WABCO OnGuardACTIVE Collision Mitigation System is intended solely as an aid for an alert and conscientious professional driver. It is not intended to be relied upon to operate a vehicle. Use the system in conjunction with rearview mirrors and other instruments to safely operate the vehicle. Operate a vehicle equipped with OnGuardACTIVE in the same safe manner as if the CMS were not present.

The OnGuardACTIVE Collision Safety System is not a substitute for safe, normal driving procedures, nor will it compensate for any driver impairment such as drugs, alcohol, or fatigue.

Failure to drive safely and use the system properly could result in personal injury and/or death and severe property damage.

System Limitations

The OnGuardACTIVE Collision Mitigation System may provide little or no warning of hazards such as pedestrians, animals, oncoming vehicles, or cross traffic.

The OnGuardACTIVE CMS only brakes for lead vehicles located directly in front of your vehicle, and does not operate when vehicle speed is less than 15 mph (25 km/h).

Due to these limitations, the system:

- will not react and alert the operator to objects crossing in front of the vehicle or oncoming traffic;
- should not be relied on to track lead vehicles when traveling through a severe curve in the road. Because of this, ACC is not recommended for use on winding roads;
- should not be relied upon to track narrow objects like motorcycles, mopeds, bicycles, or pedestrians;
- should not be relied on to alert drivers to vehicles in an adjacent lane.

OnGuard Display Unit

The OnGuardACTIVE CMS controls are located in the display unit. The display provides visual and audible warnings and messages, as well as verification of correct system operation and faults. Menu selections are made by pressing the up and down arrows, and the MODE button. See Fig.256, [OnGuard Display Unit](#).

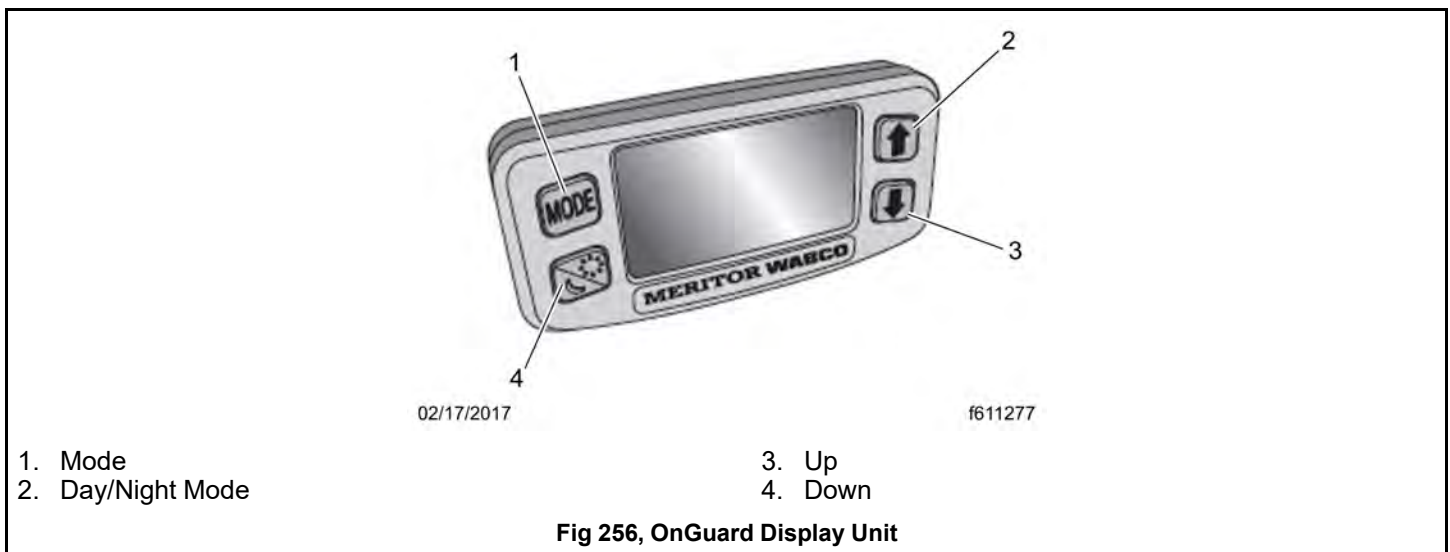

The display unit includes:

- an internal speaker

- a graphic display
- buttons to scroll and select options
- day/night display mode (second-generation only)

Collision Warning System (CWS)

The CWS generates audible, visual, and vibrational alerts when the following distance may result in a collision. The OnGuard display unit shows a graphic of the condition, enhanced by a screen color relevant to the intensity of the situation. See Table.31, [OnGuard Display Screen Background Colors](#).

| Screen Color | Description |
|--------------|---|
| Blue | General operation; no lead vehicles detected. |
| Green | Lead vehicle detected. |
| Yellow | Following distance alert, accompanied by an audible alert. |
| Red | Collision warning, stationary object warning. Accompanied with audible alert. |
| Amber | Data Error |

Table 30, OnGuard Display Screen Background Colors

If a potential collision is developing and the driver does not take action to slow the vehicle, OnGuardACTIVE's active braking feature issues a short brake pulse and de-throttles the engine.

If the driver does not take the appropriate action and a potential collision still exists, OnGuardACTIVE reduces the engine torque and applies the engine and service brakes to slow the vehicle.

The active braking application is intended only to provide early braking; the driver is still required to recognize and react to all driving situations.

If OnGuardACTIVE detects a stationary object (such as a disabled car), it will provide an audible alert followed by a vibrational alert and then brake to reduce the vehicle's speed.

Again, the active braking application is intended only to provide early braking; the driver is still required to recognize and react to all driving situations.

IMPORTANT: the collision mitigation system (CMS) and active braking are not operational at vehicle speeds below 15 mph (25 km/h).

The collision warning system (CWS) cannot be disengaged or turned off, and is always active at vehicle speeds above 15 mph (25 km/h).

Standby

When no lead vehicle is detected, the display shows that the CMS is on and the radar is searching. See Fig. 257, [CMS Standby \(blue\)](#).

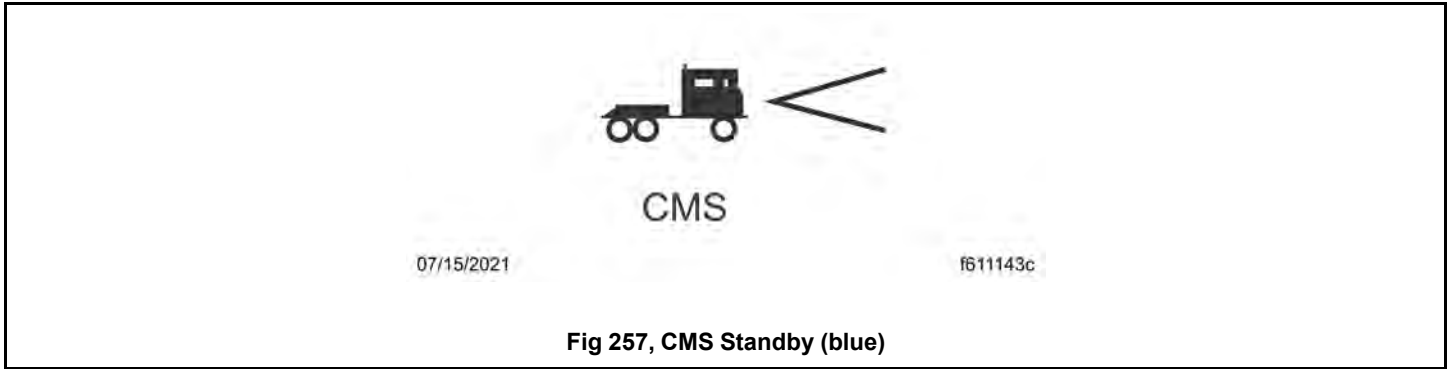

A Vehicle is Detected

When a lead vehicle is detected in the lane ahead, the display shows that the CMS is on and the radar is tracking a lead vehicle at the speed shown. See Fig.258, [CMS Lead Vehicle Detected \(green\)](#).

If the following distance between the vehicle and the lead vehicle is too close, the CMS will emit an audible alert and the display background will turn yellow. The alert will end when the vehicle speed drops below the lead vehicle speed and the following distance is increased.

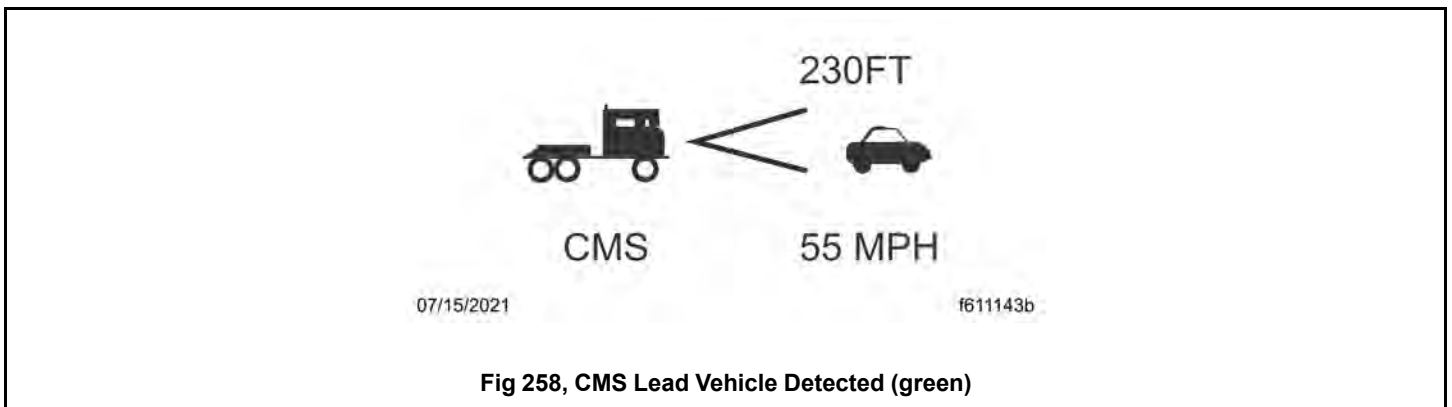

Collision Warning

When a lead vehicle is detected traveling slower than your vehicle, or the gap between them becomes too close, the CMS warns of an impending collision by emitting an urgent audible alert and displaying the collision warning symbol with a red background. See Fig.259, [CMS Collision Warning \(red\)](#).

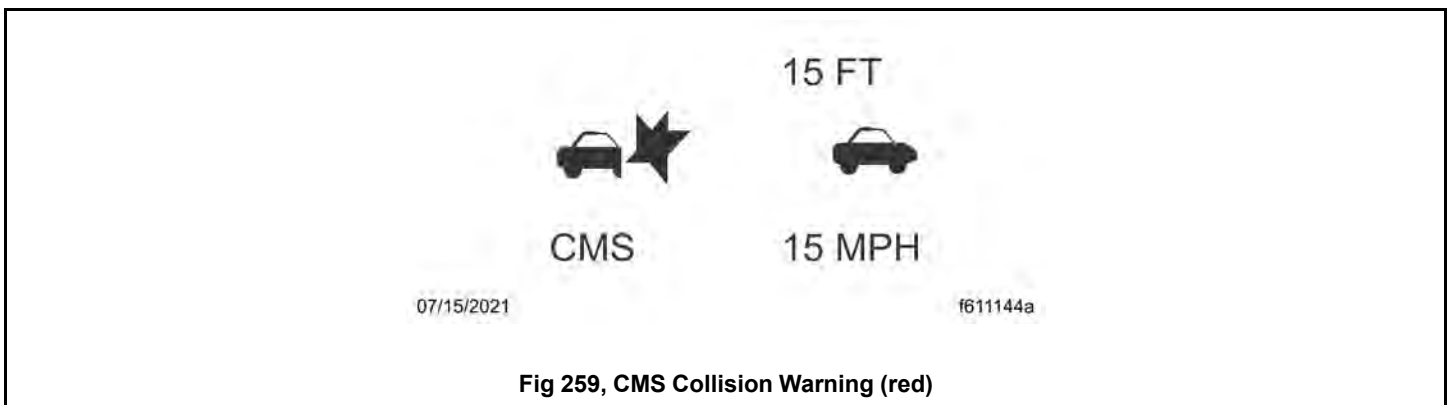

Adaptive Cruise Control (ACC)

Adaptive Cruise Control (ACC) works in conjunction with conventional cruise control to maintain a minimum following distance when a lead vehicle is being tracked. The minimum following distance is maintained by automatically decelerating the vehicle using accelerator pedal, engine, and service brakes without driver intervention.

When the lead vehicle is no longer being tracked, the set cruise control speed resumes automatically.

Vehicles equipped with the WABCO OnGuard CMS and Cummins engines come standard with Adaptive Cruise Control (ACC) and Adaptive Cruise Control Recovery enabled.

If ACC is not available, the cancel button must be used to engage standard cruise control.

To obtain cruise control when the adaptive cruise control function has been interrupted, press the pause button 2 times (ON-OFF-ON-OFF) and then press the set button once.

A Set or Resume command on the Set, Resume buttons will now engage the standard cruise control features.

Standby

When no lead vehicle is detected, OnGuard ACC operates similarly to conventional cruise control. The cruise control set speed is shown on the OnGuard display unit. See Fig.260, [ACC Standby \(blue\)](#).

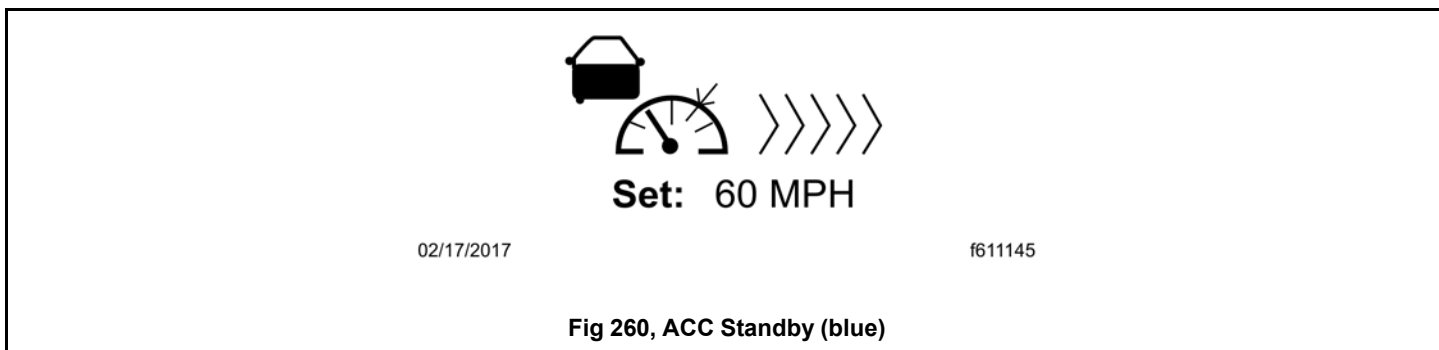

Lead Vehicle Detected

When a lead vehicle is detected in the lane ahead, the display shows that ACC is on and the radar is tracking it. See Fig. 261, [ACC Lead Vehicle Detected \(green\)](#).

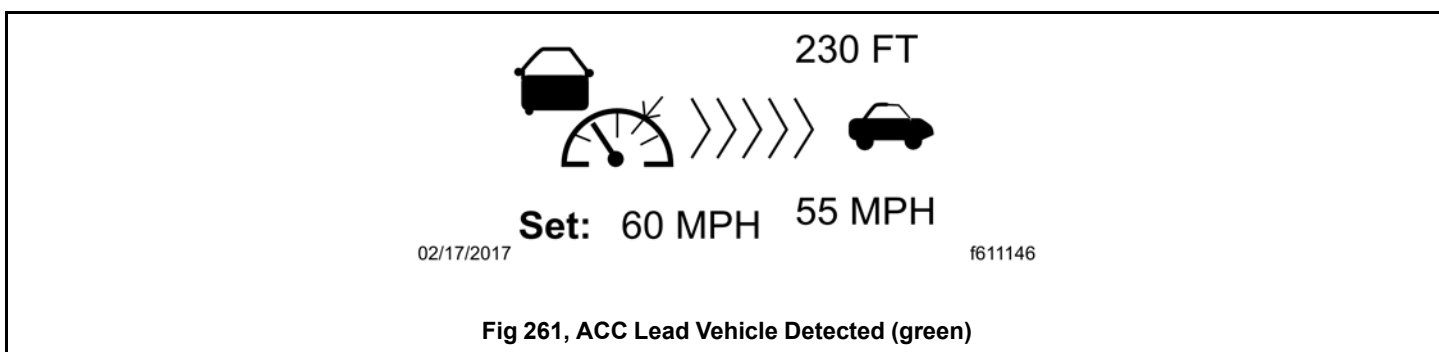

If the driver uses the accelerator pedal to override the cruise control and approach a vehicle too closely, the ACC will emit an audible alert and the display background will turn yellow. The alert will end when vehicle speed drops below the lead vehicle's speed and the following distance is increased.

NOTE: The following distance alert does not operate at speeds below 15 mph (25 km/h) or above 77 mph (124 km/h).

Collision Warning

If the lead vehicle is traveling slower than the driver's vehicle, the CMS warns of an impending collision by emitting an urgent audible alert and displaying the collision warning symbol with a red background. See Fig.262, [ACC Collision Warning \(red\)](#).

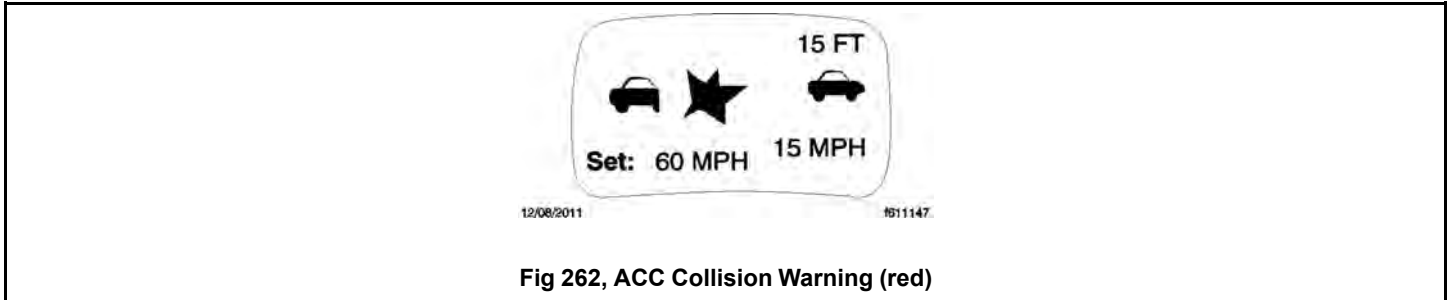

Fig 262, ACC Collision Warning (red)

If the system determines a rear end collision is imminent, it will automatically apply the brakes to reduce the vehicle's speed. The driver may also feel a short brake pulse to warn of an imminent collision. The driver must also initiate braking.

If OnGuardACTIVE detects a stationary object (such as a disabled car), it will sound an urgent audible alert, then a brake pulse, then apply the vehicle's brakes to reduce the vehicle's speed. The driver must also initiate braking.

Error Screens

IMPORTANT: The OnGuard collision mitigation system is not operational when an error screen is displayed. If a fault occurs or OnGuard fails to properly track a vehicle, take the vehicle in for service as soon as possible. Standard cruise control will not function with an active OnGuard system fault.

If a system fault is detected, the OnGuard display unit will immediately display an error screen as shown in Fig. 263, [OnGuard Error Screen \(amber\)](#). The first error code transmitted will be displayed first; additional faults (if any) can be viewed using the up or down buttons. The display does not show stored fault codes.



Fig 263, OnGuard Error Screen (amber)

Refer to the **OnGuard and OnGuardActive Collision Mitigation Systems Maintenance Manual** for a full list of error screens and messages. (www.meritorwabco.com).

Additional Features

Press the MODE button to access the OnGuard display unit additional features from the CMS or ACC main operating screen. Press the up and down arrows to scroll through each menu, then press the MODE button to select the value to be changed. In edit mode, press the up or down arrows to change a value setting, then press the MODE button to save the setting. Pressing MODE in each feature screen advances the display to the next feature.

The Display Control menu allows adjustment of the alarm volume, LCD brightness, LCD contrast, and U.S./metric unit conversion. See Fig.264, [Display Control Menu](#).



Fig 264, Display Control Menu

The component test menu provides verification of system component operation and acts as a valuable OnGuard system diagnostic tool. The header will display either COMPONENT TEST or ACC FUNCTION, depending on the software release version of the OnGuard system. The component test screen shown in Fig.265, [Component Test Menu](#) provides access to the following components (press the up or down arrows to scroll through the menu):

- brake pedal position

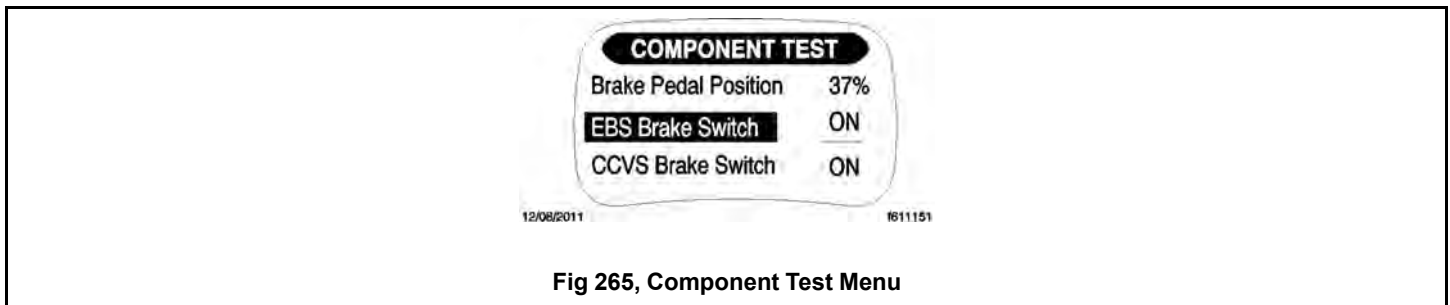

Fig 265, Component Test Menu

- EBS brake switch
- CCVS brake switch
- clutch switch
- park brake switch
- accelerator pedal position
- driveline engaged
- cruise control enable
- cruise control set speed switch
- cruise control coast switch
- cruise control resume switch
- cruise control accelerate switch
- cruise control pause switch

8.10 Zonar® 2020 Tablet

The Zonar 2020 on-board tablet is an optional feature that tracks hours of service, posts driver alerts, documents pre- and post-trip vehicle inspections, and provides advanced navigation. See Fig.266, [Detroit Connect Tablet](#).



Fig 266, Detroit Connect Tablet

The tablet operates in conjunction with the connectivity onboard platform to provide communication between drivers and fleet managers.

Refer to Zonar user documentation for more information.

8.11 SafetyDirect® by Bendix

8.11.01 Bendix Forward Facing Camera



WARNING:

SafetyDirect by Bendix is solely intended as a support for a conscientious professional driver.

IMPORTANT: In order for the forward facing camera to operate properly, the windshield area in front of the camera must be clean, unobstructed, and not be damaged in any way.

SafetyDirect by Bendix is a fleet management system that automatically records ten to twenty seconds of video during a safety event and delivers it and other vehicle safety data wirelessly and in real time to the Bendix SafetyDirect portal.

If equipped, the SafetyDirect system uses the telematics systems of the vehicle and a Bendix 5G forward facing video camera, shown in Fig.267, [Multipurpose Camera 2 and Bendix Camera Brackets](#). The Bendix camera records in color and can capture high-quality video in low light conditions.



1. Multipurpose 2 Camera Bracket

2. Bendix Forward Facing Camera Bracket

Fig 267, Multipurpose Camera 2 and Bendix Camera Brackets

8.11.02 The Bendix SafetyDirect Portal

**WARNING:**

SafetyDirect by Bendix is solely intended as a support for a conscientious professional driver.

IMPORTANT: In order for the forward facing camera to operate properly, the windshield area in front of the camera must be clean, unobstructed, and not be damaged in any way.

SafetyDirect by Bendix is a fleet management system that automatically records ten to twenty seconds of video during a safety event and delivers it and other vehicle safety data wirelessly and in real time to the Bendix SafetyDirect portal.

If the vehicle is equipped with the SafetyDirect system, data is sent from the vehicle's safety systems to the portal. The portal presents each driver's behavior in a 'miles between events' format with the following events recognized:

- lane departure warning
- excessive lane departure warning
- lane change without turn signal
- loss of video tracking
- lane departure warning system disabled
- distance/tailgate alert given
- forward collision warning
- collision mitigation braking
- automatic traction control (ATC) activation
- antilock braking system (ABS) activation
- stability system activation
- excessive braking
- excessive speed on curves
- average following distance
- adaptive cruise control usage

| | |
|---|-----|
| 9.01 Cab Climate Controls | 302 |
| 9.01.01 General Description, Cab Climate Controls | 302 |
| 9.01.02 Fan Knob | 302 |
| 9.01.03 Temperature Control Knob..... | 303 |
| 9.01.04 Mode Control Knob | 303 |
| 9.02 Sleeper Climate Control Panel | 304 |
| 9.02.01 General Description, Sleeper Climate Control Panel..... | 304 |
| 9.02.02 Fan Switch | 304 |
| 9.02.03 Temperature Control Knob..... | 305 |
| 9.02.04 Smartway Certified Parked Heater Operation..... | 305 |
| 9.03 Accessory Heaters | 306 |
| 9.03.01 General Description, Accessory Heaters..... | 306 |
| 9.03.02 Eberspaecher (Espar) Heater | 306 |
| 9.03.03 Webasto Heater..... | 308 |
| 9.04 Dual HVAC System | 309 |
| 9.04.01 General Description, Dual HVAC System..... | 309 |
| 9.04.02 Dual HVAC Control Panel..... | 309 |

9. Climate Controls

9.01 Cab Climate Controls

9.01.01 General Description, Cab Climate Controls

NOTE: On vehicles equipped with the ICC5 instrument panel, the fan speed, temperature, and mode temporarily appear on the 10-inch infotainment screen when these items are adjusted.

The standard cab climate controls include a fan knob with a recirculation button, temperature control knob with an A/C button, and a mode control knob. See Fig.268, [Cab Climate Controls](#). The mode control knob in sleeper cabs is equipped with a bunk override button.

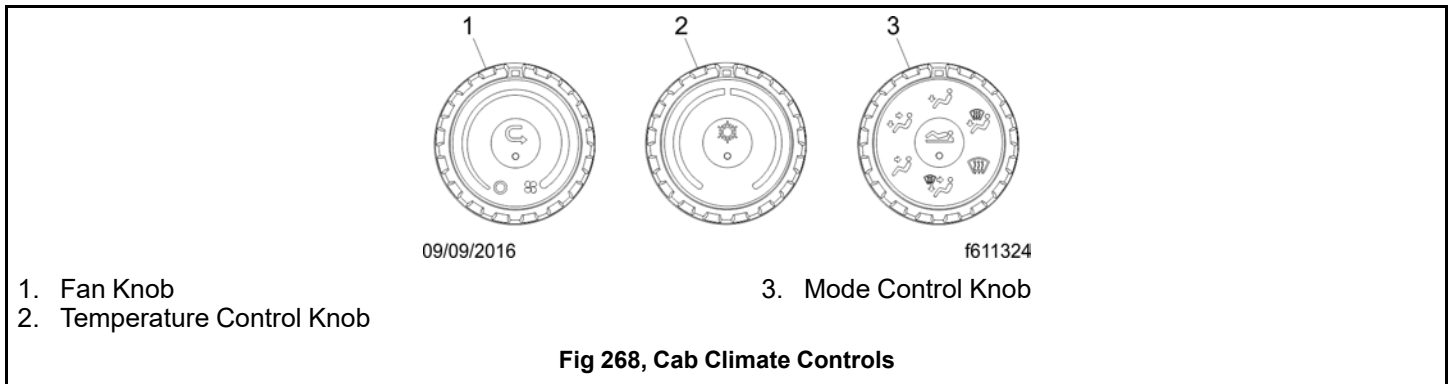

9.01.02 Fan Knob

The fan knob activates the fan, which forces outside air or recirculated air through the air outlets. The fan knob has ten fan speed settings and an OFF position. See Fig.269, [Fan Knob](#).

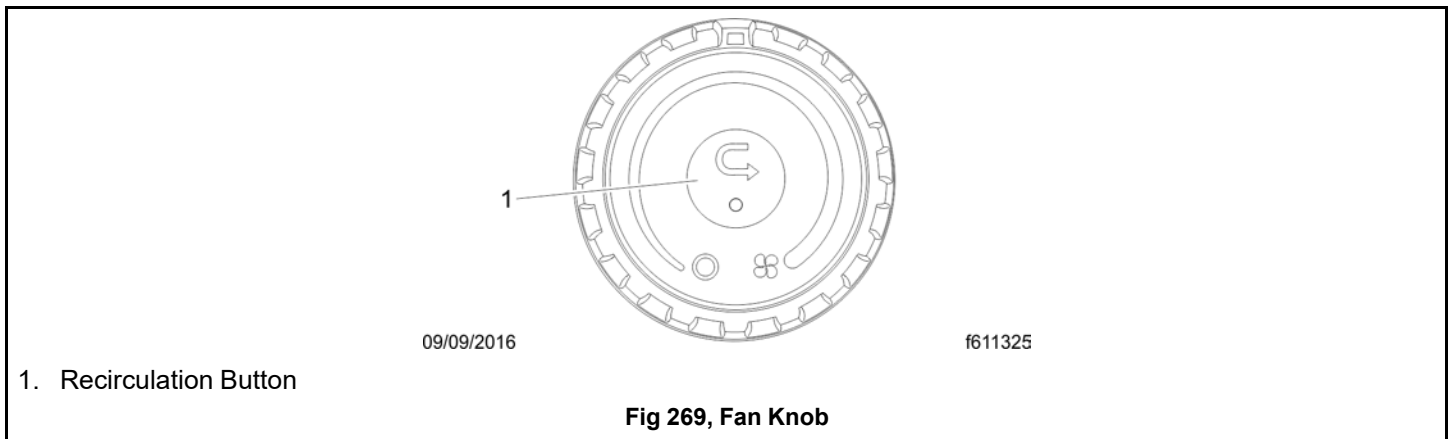

To operate the fan, turn the fan knob clockwise to increase airflow; turn the fan knob counterclockwise to decrease airflow.

There is a two-second delay between the time the engine is started and the blower is operational. It can take an additional four seconds for the blower to reach high speed. The blower motor performs a self-test immediately after the engine is started, which causes the delay. If the vehicle has Optimized Idle, the fan will not operate with the key in accessory mode. Optimized Idle may also turn the fan off to reduce stress on the batteries. Refer to the **Optional Engine Systems** chapter for more information.

Recirculation

Recirculation mode limits the amount of outside air entering the cab. Press the recirculation button to prevent dusty or smoky air from entering the cab. See Fig.269, [Fan Knob](#). Recirculation mode can also decrease the time required to cool or heat the cab interior during extreme outside temperature conditions. An amber indicator on the recirculation button will illuminate when the recirculation mode is activated.

The recirculation button will not work when the mode control switch is in either defog or defrost modes.

NOTE: To prevent the buildup of odors or oxygen depletion inside the cab, the system switches from full recirculation mode to partial recirculation mode after 20 minutes. In extremely dusty or smoky conditions, the partial recirculation mode can be overridden by pressing the recirculation button twice to obtain full recirculation mode. This resets the 20-minute timer.

9.01.03 Temperature Control Knob

The temperature control knob is used to select the desired temperature in the cab. Turn the knob counterclockwise for cool air, or clockwise for hot air. See Fig.270, [Temperature Control Knob](#).

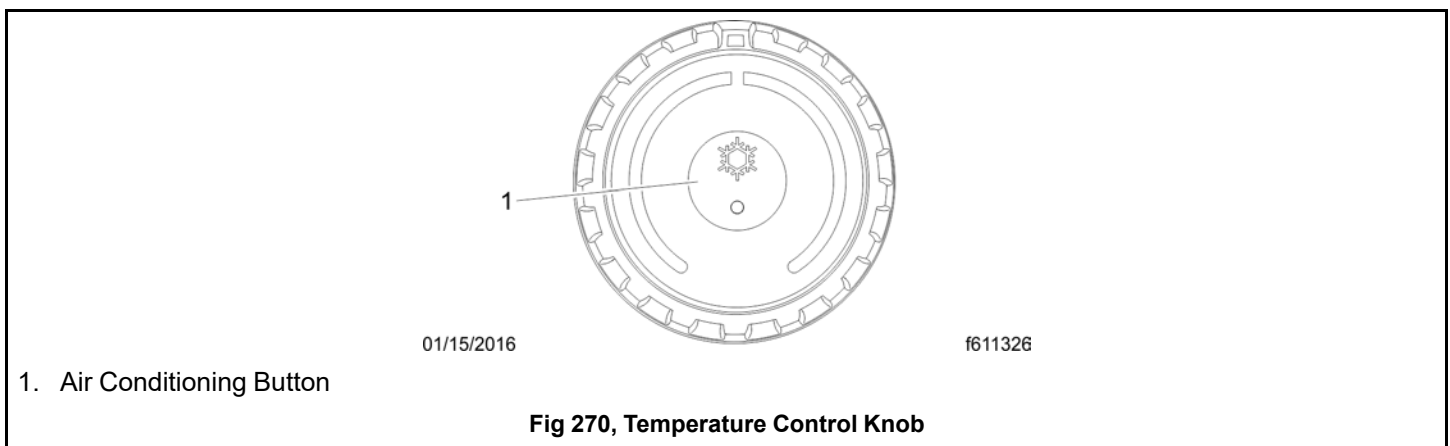

Air Conditioning Button

The air conditioner (A/C) cools and dehumidifies the air inside the cab. Press the A/C button, located in the center of the temperature control knob, to turn the air conditioner on and off. See Fig.270, [Temperature Control Knob](#). The A/C has three modes:

- Off
- Economy (ECO); green LED
- Full A/C (maximum cooling); blue LED

The ECO mode does not cool the air temperature as low as the full A/C mode, and can provide fuel savings.

When using the climate control in full A/C mode (blue LED illuminated), after 45 minutes the system will automatically switch to ECO mode (green LED illuminated) to improve fuel economy. Full A/C can be reset by pushing the A/C button again.

9.01.04 Mode Control Knob

The mode control knob allows the driver to control the flow of air through the face outlets, the floor outlets, the defrost (windshield) outlets, or a combination of these outlets. See Fig.271, [Mode Control Knob With Bunk Override Button](#).

- **Face Mode:** Directs all airflow through the face or instrument panel outlets.
- **Bi-Level Mode:** Directs the airflow equally to the face outlets and the floor outlets.
- **Floor Mode:** Directs all airflow through the floor outlets.
- **Floor/Defrost Mode:** Directs the airflow equally to the floor outlets and the defrost outlets.
- **Defrost Mode:** Directs all airflow through the defrost outlets.

- **All Mode:** Directs the airflow equally to the face, floor, and defrost outlets.

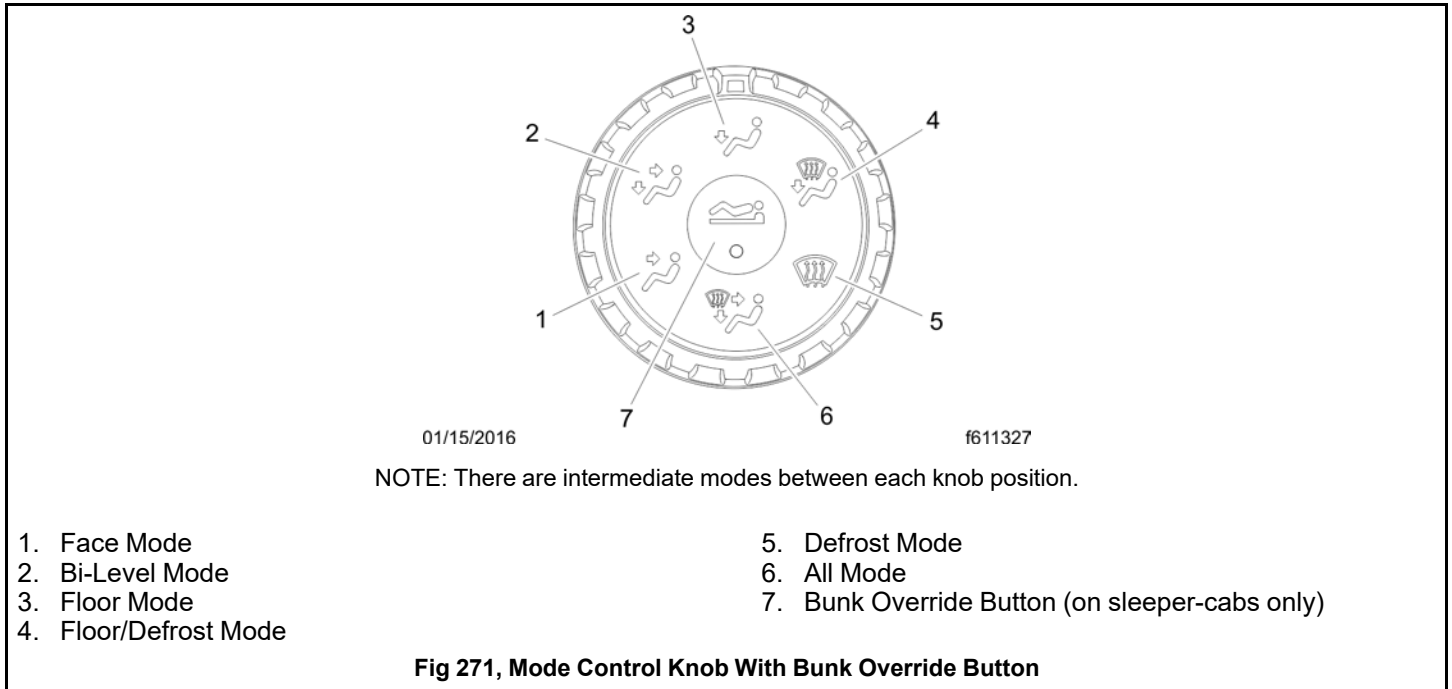

NOTE: There are intermediate modes between each knob position.

Bunk Override Button

The bunk override button, equipped on sleeper cabs only, copies the temperature and fan settings from the cab to the sleeper. See Fig.271, [Mode Control Knob With Bunk Override Button](#).

Pressing the bunk override button in either the cab or the sleeper will copy the current cab HVAC temperature and fan settings to the sleeper HVAC. An amber indicator will illuminate when bunk override mode is activated. When in override mode, the sleeper climate control panel automatically conforms to the fan speed and temperature settings on the cab climate panel at the time the override mode is activated. Further changes of the cab climate control settings will not alter the settings of the sleeper climate control panel.

The override mode is disabled when the fan or temperature control knob on the sleeper climate control panel is manually set to a different setting. The override mode is also disabled when the bunk override button is pressed to the off position in the cab.

9.02 Sleeper Climate Control Panel

9.02.01 General Description, Sleeper Climate Control Panel

The standard sleeper climate control panel has a fan knob and a temperature control knob with an A/C button.

If the bunk override button has been activated, the override mode can be canceled by changing the sleeper fan speed or temperature setting. The climate control system will then operate from the sleeper controls.

9.02.02 Fan Switch

The fan knob activates the fan, which forces air through the air outlets. The fan knob has ten fan speeds and an OFF position. See Fig.272, [Sleeper Climate Control Panel](#).

To operate the fan knob, turn the knob clockwise to increase airflow; turn the fan knob counterclockwise to decrease airflow. If the vehicle has Optimized Idle, the fan will not operate with the key in accessory mode. Optimized Idle may also turn the fan off to reduce stress on the batteries. Refer to the **Optional Engine Systems** chapter for more information.

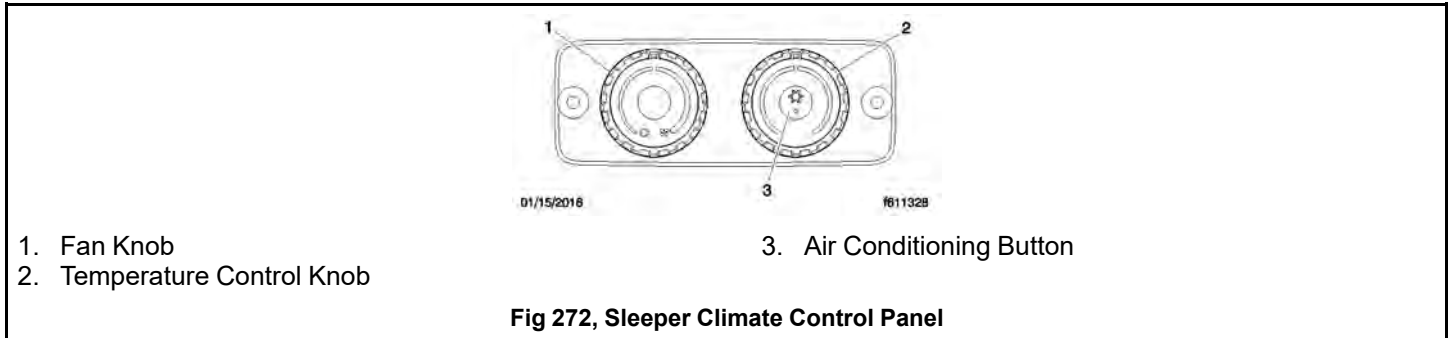

When the cab air conditioner (A/C) is on, it is normal for the sleeper fan to operate at low speed even if the sleeper fan knob is in the off position. This is necessary to protect the evaporator in the sleeper heater and air conditioner system from freezing. At lower fan speed settings, a slight increase in airflow levels may appear at times, as the control acts to regulate the evaporator temperature.

When the park brake is set, any temperature or blower speed setting changes on the bunk HVAC unit control panel will be mimicked by the front HVAC unit. For example, if you set bunk blower speed to HI and the temperature to COLD, the front unit will also operate on HI/COLD.

When the park brake is not set, the front and rear HVAC settings function independently, unless the bunk override button is pressed, or "minimum AC support" is required.

Minimum AC support is when the front unit is off and the bunk unit is set such that AC is requested (needs the AC compressor to run). In this case, the front unit will go into minimum AC support mode by operating the front blower at minimum speed to prevent the front unit evaporator from freezing up. This is also true, if the rear unit is off and the front unit is set such that AC is requested, in order to prevent the bunk evaporator from freezing up.

9.02.03 Temperature Control Knob

The temperature control knob is used to select the desired temperature in the sleeper. Turn the switch counterclockwise for cool air, or clockwise for hot air.

Air Conditioning Button

The A/C cools and dehumidifies the air inside the sleeper. Press the air conditioning button, located in the center of the temperature control knob to turn the A/C on and off.

9.02.04 Smartway Certified Parked Heater Operation

General Description, Smartway Certified Parked Heater

All vehicles equipped with diesel operated coolant heaters are 'Smartway Certified.' The coolant heater will keep the engine coolant between approximately 150 and 180°F (65 and 82°C). Heated coolant is routed through the auxiliary HVAC heater core to allow heater-only function of the auxiliary HVAC system.

System Operation, Smartway Certified Parked Heater

1. Turn the block heater on.
2. Set the temperature dial to the desired heat setting.
3. Turn the HVAC blower on.

9.03 Accessory Heaters

9.03.01 General Description, Accessory Heaters

Optional accessory heaters are available from the factory in several configurations. Familiarize yourself with the equipment on your specific vehicle, and follow the manufacturer's operating and maintenance instructions.

**WARNING:**

Do not operate fuel-operated heaters in an area where flammable vapors, including gasoline or diesel fumes, are present, such as at filling stations and oil depots. Turn off a fuel-operated heater and allow it shut down completely before entering an area where flammable gases or liquids are present. Heaters continue to operate for up to three minutes after being turned off.

Failure to observe these precautions could cause an explosion or fire, resulting in serious property damage, and personal injury or death.

**NOTICE:**

Always ensure that air inlet and outlet grilles are not restricted. Restriction of any air inlet or outlet ports could result in damage to the auxiliary heater.

IMPORTANT: To maintain reliable performance, run the accessory heater for at least 15 minutes every month to prevent fuel from degrading.

On vehicles without Optimized Idle, accessory heaters function when the ignition switch is in the OFF position and the cab load disconnect switch (if equipped) is in the ON position.

On vehicles with Optimized Idle, accessory heaters function when the ignition switch is in the ON or ACC position, the cab load disconnect switch (if equipped) is in the ON position, and the parking brake is engaged. The heater may run briefly after the ignition key has been turned to the OFF position.

IMPORTANT: Wait eight minutes after shutting down an accessory heater before turning the cab load disconnect switch (CLDS) to OFF.

NOTE: The low voltage disconnect (LVD) control prevents a heater from draining the batteries below starting voltage.

9.03.02 Eberspaecher (Espar) Heater

Refer to the Eberspaecher website, www.eberspaecher-na.com, for additional information.

Eberspaecher Digi-Max D1000 Controller

To turn the heater on, press the POWER button. See Fig.273, [Eberspaecher Digi-Max D1000 Controller](#). The display will indicate that heater is enabled and show the remaining runtime and the set temperature. See Fig.274, [Controller LCD](#). The green LED indicates that the heater is on.

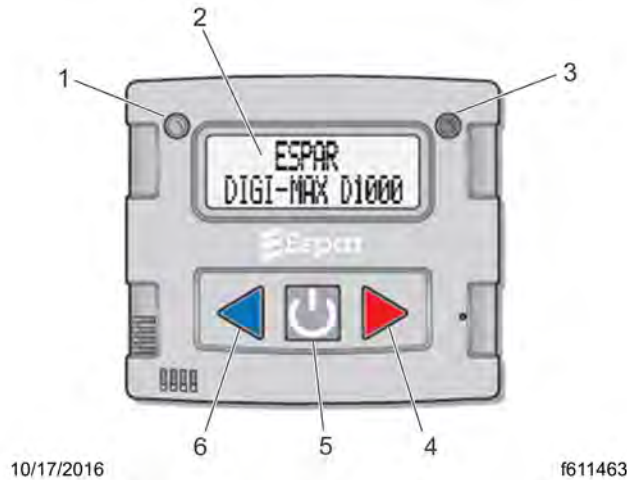

- | | |
|-----------------------------------|---|
| 1. Heater Enabled LED (green) | 4. Temperature UP Button (right arrow) |
| 2. LCD Display | 5. Power Button |
| 3. Maintenance Required LED (red) | 6. Temperature DOWN Button (left arrow) |

Fig 273, Eberspaecher Digi-Max D1000 Controller

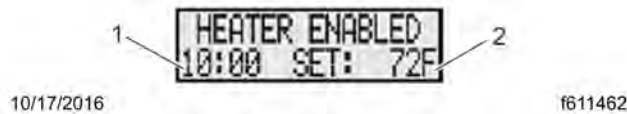

- | | |
|----------------------|--------------------|
| 1. Remaining Runtime | 2. Set Temperature |
|----------------------|--------------------|

Fig 274, Controller LCD

To adjust the desired temperature, press the left or right arrow buttons. The left arrow button lowers the desired temperature, and the right arrow button raises it. The adjustment range is from 48 to 93°F (8 to 34°C).

To turn the heater off, press the POWER button again. The heater will initiate a 5- to 8-minute cooling cycle.

The controller has a real-time diagnostic feature, and will automatically display fault codes as they happen (e.g. 48 Check Fuel Pump). The red LED will illuminate, indicating that maintenance is required.

The controller has a programmable run timer that will display a maintenance message on the LCD after the set time limit when the heater is off. See Fig.275, [Maintenance Required Message](#). The fault codes and maintenance messages will not prevent the heater from operating, but they reflect conditions that should be addressed promptly.



Fig 275, Maintenance Required Message

9.03.03 Webasto Heater

General Description, Webasto Heater

Webasto heaters have a heat mode and a vent mode. The fan speed is adjustable in the vent mode. The control also has a timer function, allowing a start time and/or duration to be set.

To turn the heater on, push the ON/OFF button. See Fig.276, [Webasto Temperature Control](#). The LCD screen displays the mode, ambient temperature, set temperature, timer, and fan speed. See Fig. 277, [Webasto Temperature Control Display Screens](#).

Refer to the Webasto website, see techwebasto.com, for additional information.

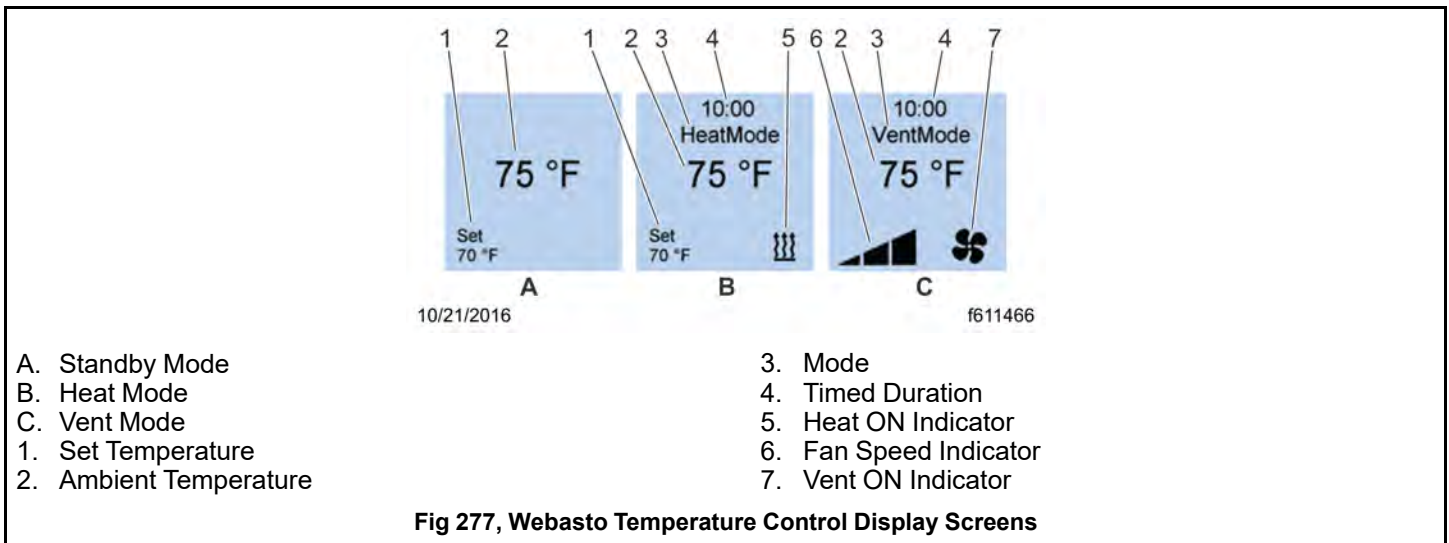

Setting the Temperature and Heater Runtime

1. Press the selection button.

2. Using the rotary knob, select 'Options' > 'Duration' > 'Timed' > 'Adjust Runtime to xx Hours.' Confirm the adjustment by pressing the selection button.
3. Using the rotary knob, adjust the control to the desired temperature. Confirm the adjustment by pressing the selection button.

NOTE: The temperature can be adjusted while the heater is running.

Setting the Timer

1. Press the selection button.
2. Using the rotary knob, select 'Timer.'
3. Press the selection button. Select 'Edit' from the sub-menu.
4. Using the rotary knob, select the day. To confirm, press the selection button.
5. Using the rotary knob, select the start time. To confirm, press the selection button.
6. Using the rotary knob, select the run time. To confirm, press the selection button.

9.04 Dual HVAC System

9.04.01 General Description, Dual HVAC System

The Dual HVAC system replaces the standard sleeper HVAC when optioned. Vehicles with a Dual HVAC system have a larger alternator, additional batteries, and premium insulation. The Dual HVAC system operates both when the engine is running and when the engine is off.

The Dual HVAC system controls temperature differently than the standard sleeper HVAC system. The standard sleeper HVAC (without Optimized Idle) attempts to maintain vent discharge temperature at the sleeper vents, much like the main HVAC in the dash. The Dual HVAC system is a zone control system which attempts to hold the bunk at a constant temperature.

The Dual HVAC system has two evaporators for cooling, one supported by the engine-driven A/C system, and the other on a separate battery-powered A/C loop with a back wall-mounted condenser. When the engine is running, the Dual HVAC system uses the traditional engine-supported systems for heating and cooling. When the engine is turned off, the vehicle batteries power the separate electric air conditioner loop or support a fuel-operated heater.

Operation of the Dual HVAC system is regulated by the cab Progressive Low Voltage Disconnect (PLVD). The PLVD must be enabled for the Dual HVAC system to be started. The PLVD will stop operation of the Dual HVAC system when the voltage gets below a pre-determined threshold. Before operating the Dual HVAC system, bring the sleeper interior temperature to the desired temperature with the engine running and the bunk curtain open. The Dual HVAC system is designed to maintain an established comfortable bunk temperature in parked mode for up to 12 hours with the bunk curtain closed.

NOTE: The condition and charge of the vehicle batteries will directly affect the run time of the Dual HVAC system. If the vehicle run time between discharges is less than eight hours, or if additional loads are added to the vehicle batteries, the Dual HVAC system run time will be less than expected.

9.04.02 Dual HVAC Control Panel

The Dual HVAC system control panel replaces the standard sleeper control panel in Dual HVAC-equipped sleeper cabs. See Fig.278, [Dual HVAC System Control Panel](#). The Dual HVAC system is designed to maintain a comfortable temperature inside the sleeper, and can operate in combination with the cab climate control system when the vehicle is running, or independently when the vehicle is parked.

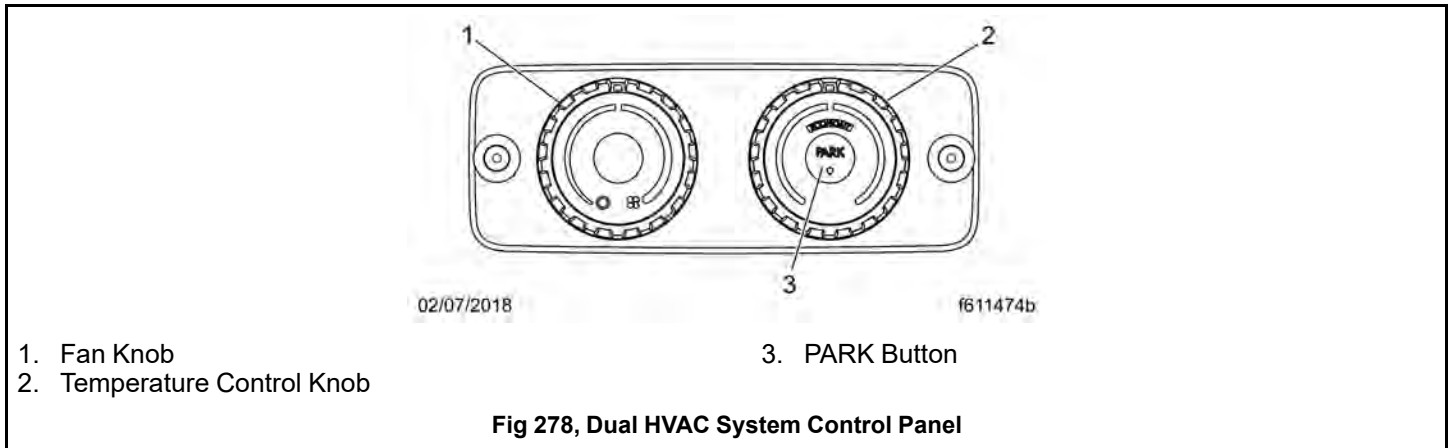

To operate Dual HVAC system, select a fan speed (other than off) and push the PARK button. Adjust the temperature control knob to the desired temperature.

The fan switch has ten fan speeds. Zero (0) is the OFF position. Turn the switch clockwise to increase airflow, and counter-clockwise to decrease airflow.

The temperature control knob controls the temperature from 65°F to 85°F (18°C to 29°C). At the minimum setting of 65°F the unit will attempt to cool the bunk to 65°F and will not allow the coolant heater to operate. At the maximum setting of 85°F the unit will attempt to heat the bunk to 85°F and will not allow the A/C cooling to operate. In between the two extremes the unit will operate in either the heating or cooling mode to achieve the set point.

On vehicles with Optimized Idle, interior comfort mode with Dual HVAC system operates with the following parameters regarding the set point and comfort zone:

- If the bunk area reaches more than 10°F (5.5 °C) above the set point the Dual HVAC system immediately requests the engine to start for bunk cooling.
- Bunk area temperature 5 to 10°F (2.8 to 5.5°C) above the set point for over twenty minutes will cause the Dual HVAC system to request the engine to start for bunk cooling.
- When the sleeper area drops to more than 10°F (5.5 °C) below the set point, the comfort zone is exceeded and the Dual HVAC system immediately requests the engine to start for bunk heating.
- Bunk area temperatures 5 to 10°F (2.8 to 5.5 °C) below the set point for over twenty minutes will cause the Dual HVAC system to request the engine to start for bunk heating.

The mid-point position on the Dual HVAC system temperature control knob is a set point of 73°F (23°C). In most conditions the mid-set point for temperature and mid-set point for fan speed will assure a stable environment. Mid-point for both controls is suggested as the initial position, with subsequent adjustment for personal preference.

IMPORTANT: Wait three minutes after shutting down the Dual HVAC system before turning the cab load disconnect switch (CLDS) to OFF.

| | |
|--|-----|
| 10.01 Seats..... | 312 |
| 10.01.01 Seats, General Information | 312 |
| 10.01.02 High Back Seat | 313 |
| 10.01.03 Sears Atlas Seat | 315 |
| 10.02 Seat Belts and Tether Belts | 317 |
| 10.02.01 General Description, Seat Belts and Tether Belts..... | 317 |
| 10.02.02 Inspection of the Seat Belt | 317 |
| 10.02.03 Operation of the Seat Belt..... | 318 |
| 10.03 Sleeper Compartment Restraints..... | 321 |
| 10.03.01 Adjustment of the Bunk Restraint | 321 |
| 10.03.02 Operation of the Bunk Restraint | 322 |
| 10.04 Steering Wheel Air Bag..... | 323 |
| 10.04.01 Steering Wheel Air Bag | 323 |
| 10.04.02 Inspection and Service | 323 |
| 10.05 RollTek Rollover Protection System | 323 |
| 10.05.01 Identification | 323 |
| 10.05.02 RollTek System..... | 324 |

10. Seats and Restraints

10.01 Seats

10.01.01 Seats, General Information

Unless otherwise noted, all seat adjustments should be made while seated and before the engine is started.

Due to the maximum adjustability of mid- and high-back air suspension seats, it is possible to combine the seat back recline adjustment and the seat slide adjustment so that the seat back contacts the backwall. It is the responsibility of the driver to adjust the seat to prevent damage to the seat and the cab interior.



WARNING:

Keep hands, tools, and other objects away from the scissor points under the seats. Failure to do so could cause personal injury.

The following is a description of adjustments that can be made to various Freightliner-installed seats. Not all seats have all of the adjustments listed below. See Fig. 279, [General Seat Adjustments](#).

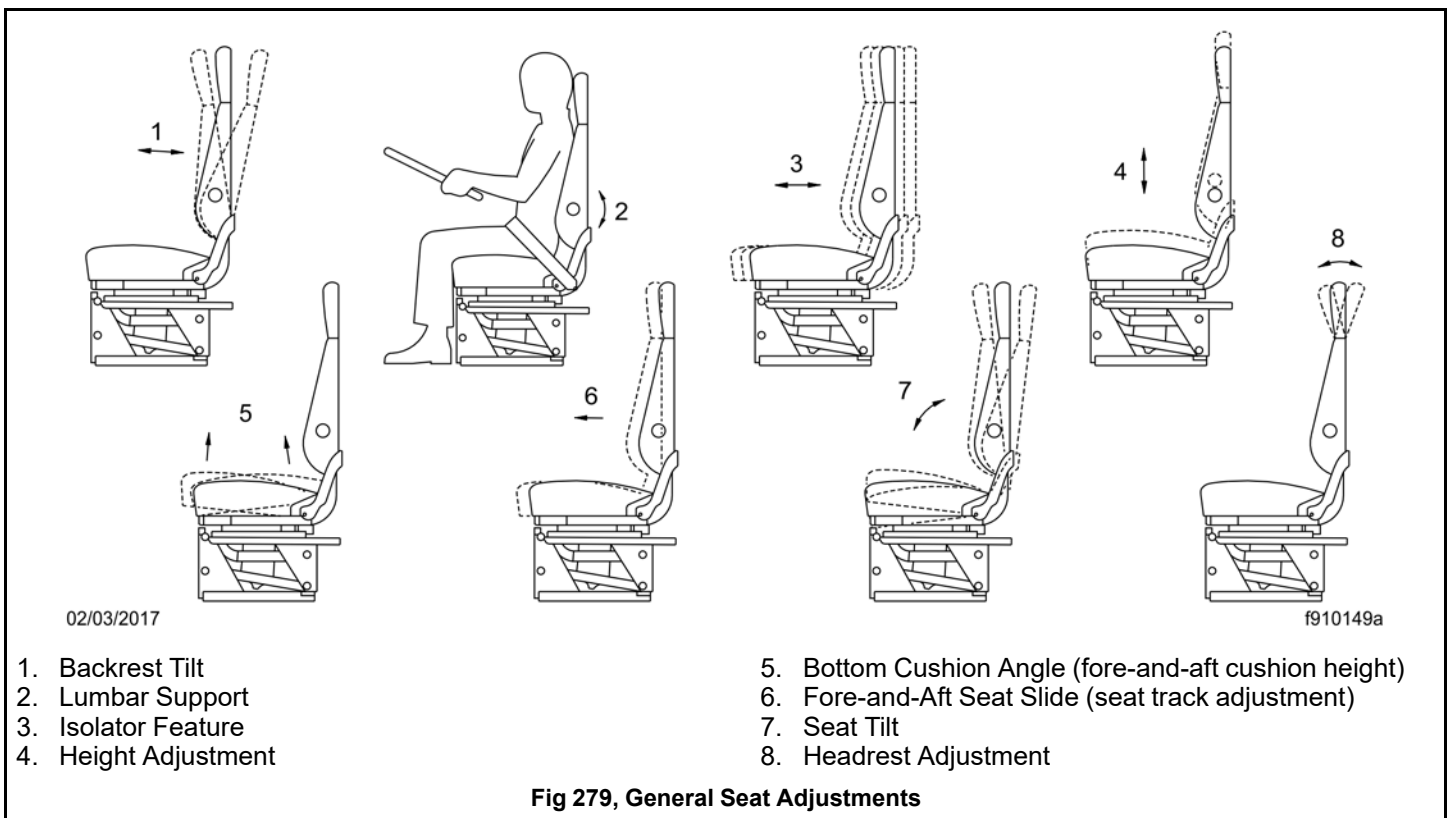

1. Backrest Tilt: This adjustment enables the backrest to pivot forward or backward.
2. Lumbar Support: Lumbar support changes the shape of the seat back to give more or less support to the occupant's lumbar (lower back) area. This adjustment is either mechanical or air controlled, depending on make and model of the seat.

3. Isolator: This feature reduces the amount of road shock by isolating the occupant from the motion of the vehicle, and allowing the upper seat to move in a simple pendulum motion. A lockout feature is used whenever the isolator is not desired.
4. Height Adjustment: This adjustment moves the entire seat up or down. The adjustment is either manual or air-controlled, depending on the make of the seat.
5. Bottom Cushion Angle, or Fore-and-Aft Bottom Cushion Height: This adjustment enables the occupant to raise or lower the front or back of the bottom cushion. This adjustment is easier to perform when all weight is removed from the seat.
6. Fore-and-Aft Seat Slide, or Seat Track Adjustment: This adjustment moves the entire seat forward or backward on its track.
7. Seat Tilt: This adjustment allows the seat assembly (back and bottom cushions) to tilt forward or backward.
8. Headrest Adjustment: This adjustment changes the angle of the upper part of the backrest to provide head and upper back support.

10.01.02 High Back Seat

See Fig. 280, [High Back Seat](#) for seat adjustment controls. Not all models of High Back seat have all the adjustments listed below.



01/14/2016

f910682b

- | | |
|-------------------------------------|-----------------------------------|
| 1. Backrest Tilt Handle | 6. Fore/Aft Isolator Lever |
| 2. Heat/Ventilation Switches | 7. Bottom Cushion Extension Lever |
| 3. Lumbar and Side Support Switches | 8. Seat Fore/Aft Slide Lever |
| 4. Height Adjustment Lever | 9. Seat Tilt Lever |
| 5. Shock Absorber Adjustment Lever | |

Fig 280, High Back Seat

**NOTICE:**

Do not install seat covers on seats with heating and ventilation. Do not cover the seat with blankets, clothing, or pillows. Blocking the air flow through the cushions can overheat and damage the seat.

- Backrest Tilt:** Pull the recline handle to adjust the backrest tilt.
- Heat/Ventilation:** Use the forward switch to turn the seat heater and ventilation ON or OFF. To turn on the heat, push the top of the switch. To turn on the ventilation, push the bottom of the switch. To turn off the heat or ventilation, move the switch to the middle position. To adjust the heat or ventilation, Use the rear button to adjust seat heating or ventilation. Three settings are available: low, medium, and high. See Fig. 281, [High Back Seat Heat/Ventilation Controls](#).

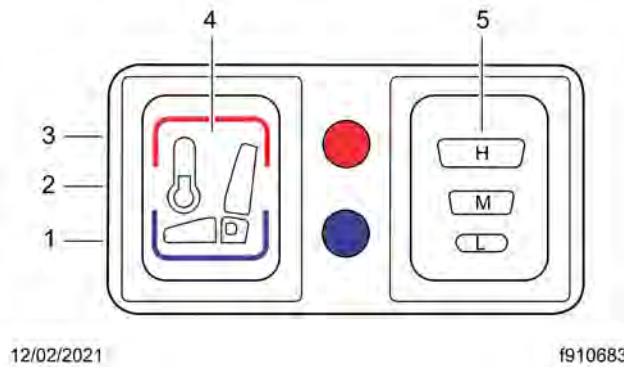

1. Ventilation ON
2. Heat/Ventilation OFF
3. Heat ON

4. Heat/Ventilation ON/OFF Switch
5. Heat/Ventilation Adjustment Switch

Fig 281, High Back Seat Heat/Ventilation Controls

IMPORTANT: Turn off seat heating/ventilation when the seat is unoccupied.

3. **Lumbar and Side Support:** Press the forward button to adjust lower lumbar support, the middle button to adjust upper lumbar support, and the rear button to adjust side support.
4. **Height Adjustment:** Pull or push the lever to adjust seat height.
5. **Shock Absorber Adjustment:** Move the lever down to increase damping on rough roads, or up to decrease damping on flat roads.
6. **Fore/Aft Isolator:** Rotate the isolator knob to the left to lock the isolator, or to the right to allow movement.
7. **Bottom Cushion Extension:** Pull the lever to move the seat cushion forwards or backwards. The cushion moves 2-3/8 inches (60 mm) in 3/8-inch (10-mm) increments.
8. **Seat Fore/Aft Slide:** Lift the lever to slide the seat forward or backward. Release the lever to lock the seat in position.
9. **Seat Tilt:** Pull the lever and lean back to tilt the seat backwards. Three positions are available.

Armrest Tilt: To adjust the armrest angle, tilt the armrest to the highest position, then down to the lowest position, then to the desired position.

10.01.03 Sears Atlas Seat

For seat adjustment controls, see Fig. 282, [Sears Atlas Seat](#).

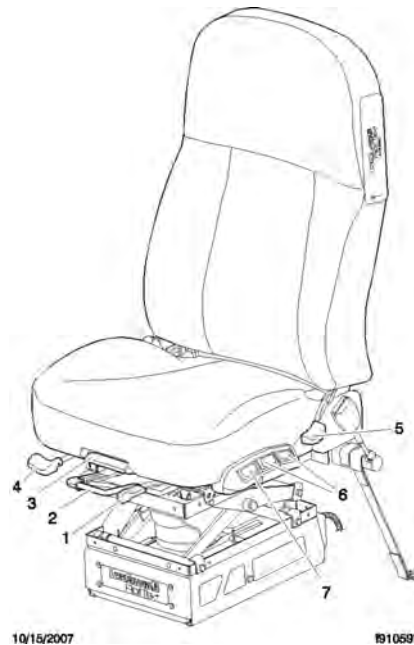

- | | |
|-------------------------------|--|
| 1. Isolator Lever | 5. Backrest Tilt Lever |
| 2. Fore/Aft Seat Slide Lever | 6. Lumbar Support Switches |
| 3. Bottom Cushion Tilt Handle | 7. Suspension Inflation/Deflation Switch |
| 4. Seat Extension Lever | |

Fig 282, Sears Atlas Seat

- 1. Isolator:** Position the handle to the left to allow isolation movement. Position the handle to the right to lock-out isolation movement.
- 2. Fore/Aft Seat Slide:** To adjust the fore-and-aft position of the entire seat, squeeze the fore/aft slide lock against the adjustment bail, and lift the bail up. See Fig. 283, [Fore/Aft Slide Adjustment, Sears Atlas Seat](#). Slide the seat forward or backward to the desired position. Release the bail and fore/aft slide lock, to its original position, to lock the seat in place.

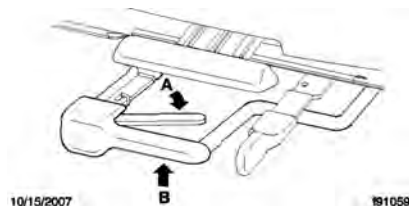

- | | |
|---|---------------------------------|
| A. Squeeze the fore-and-aft slide lock against the adjustment bail. | B. Lift up the adjustment bail. |
|---|---------------------------------|

Fig 283, Fore/Aft Slide Adjustment, Sears Atlas Seat

- 3. Bottom Cushion Tilt:** Lift the handle upward and move the seat cushion to the desired position. Three positions are available.
- 4. Seat Extension:** Rotate the handle upward to disengage, then move the seat cushion to the desired position and release the lever. Three positions are available.
- 5. Backrest Tilt:** Pull upward on the recliner handle, move the backrest to the desired position and release the handle.
- 6. Lumbar Support:** Rear rocker switch: Push forward to inflate the lower lumbar bag; push rearward to deflate the bag. Center rocker switch: Push forward to inflate the upper lumbar bag; push rearward to deflate the bag.

7. **Suspension Inflation/Deflation:** Push forward on the gray rocker switch to inflate and raise the suspension; push rearward to deflate and lower the suspension.

Armrest Angle: Rotate the control knob, located on the underside of the armrest, to set the desired angle of the armrest.

10.02 Seat Belts and Tether Belts

10.02.01 General Description, Seat Belts and Tether Belts

Seat belt assemblies are designed to secure persons in the vehicle to help reduce the chance of injury, or the amount of injury, resulting from accidents or sudden stops. For this reason, Daimler Truck North America LLC (DTNA) urges that the driver and **all** passengers, regardless of age or physical condition, use seat belts when riding in the vehicle.

**WARNING:**

Always use the vehicle's seat belt system when operating the vehicle. Failure to do so can result in severe personal injury or death.

Seat belt assemblies in DTNA vehicles meet Federal Motor Vehicle Safety Standard 209, "Type 1" and "Type 2" requirements.

When transporting a child, always use a child restraint system or the vehicle seat belts as appropriate. To determine whether a child restraint system is required, review and comply with applicable state and local laws. Any child restraint used must comply with Federal Motor Vehicle Safety Standard 213, "Child Restraint Systems." When providing a child restraint system, always carefully read and follow all instructions pertaining to installation and usage for the child. Make certain the child remains in the restraint system at all times when the vehicle is in motion.

In addition to seat belt assemblies, tether belts are installed on suspension-type seats. Tether belts help secure the seat to the floor and are intended to restrain the seat and seat belt in case of an accident or sudden stop.

IMPORTANT: Seat belts have a finite life which may be much shorter than the life of the vehicle. Regular inspections and replacement as needed are the only assurance of adequate seat belt security over the life of the vehicle.

10.02.02 Inspection of the Seat Belt

**WARNING:**

Inspect and maintain seat belts. When any part of a seat belt system needs replacement, the entire seat belt must be replaced, both retractor and buckle side. Any time a vehicle is involved in an accident, and the seat belt system was in use, the entire vehicle seat belt system must be replaced before operating the vehicle. Do not attempt to modify the seat belt system; doing so could change the effectiveness of the system. Failure to replace worn or damaged seat belts, or making any modifications to the system, may result in personal injury or death.

Inspect the seat belts and tether belts (if so equipped).

1. Check the web for fraying, cuts, extreme dirt and dust, or for severe fading from exposure to sunlight, especially near the buckle latch plate and in the D-loop guide area.
2. Check operation of the buckle, latch, Komfort Latch or Sliding Komfort Latch (if equipped), web retractor, and upper seat belt mount on the door pillar. Check all visible components for wear or damage.
3. Check the seat belt and tether belt connection points and tighten any that are loose.

10.02.03 Operation of the Seat Belt

When engaged and used properly, the Komfort Latch (see Fig. 284, [Komfort Latch](#)) and the Sliding Komfort Latch (see Fig. 285, [Sliding Komfort Latch](#)) introduce a small amount of slack into the seat belt, resulting in a more comfortable ride.

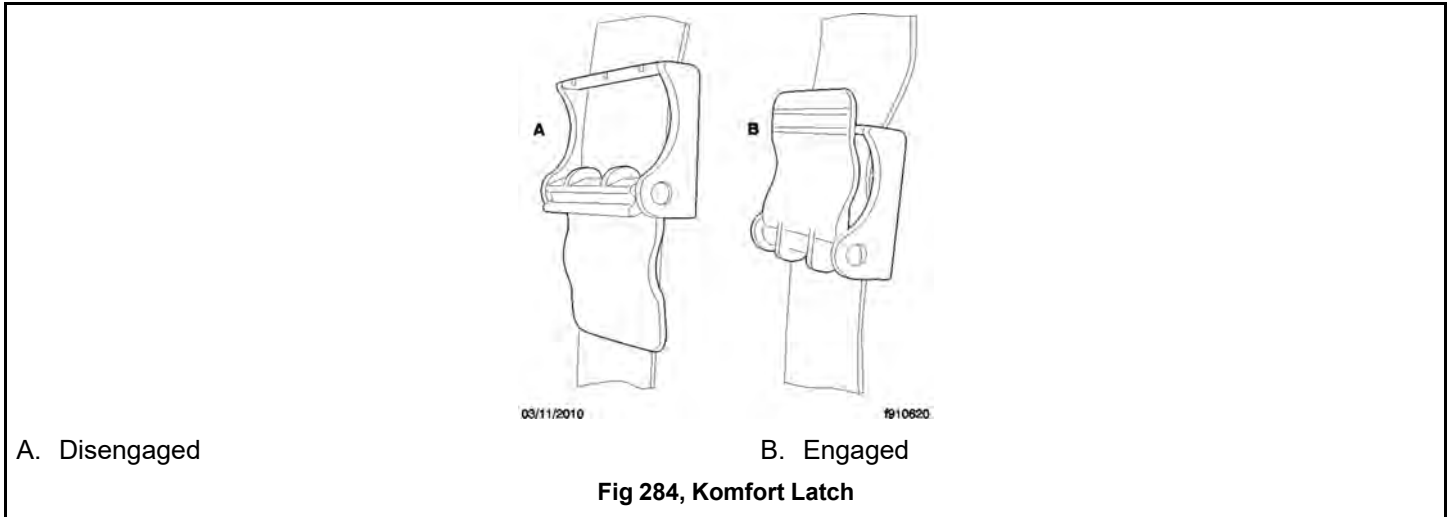

1. Slowly pull the link end of the seat belt out of the retractor and pull it across your lap (from outboard to inboard) far enough to engage the buckle. If the retractor locks too soon, allow the belt to retract slightly, then slowly pull it out again. See Fig. 286, [Three-Point Seat Belt Operation](#).

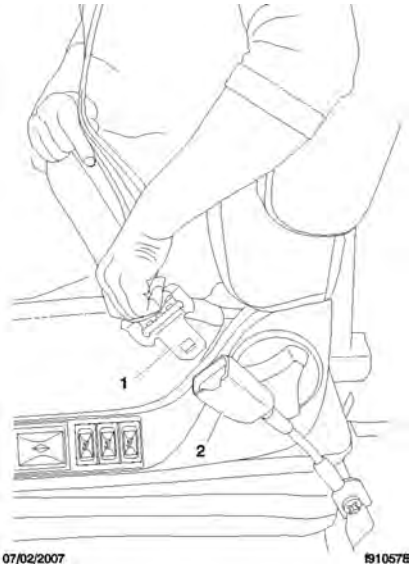

1. Latch

2. Buckle

Fig 286, Three-Point Seat Belt Operation

2. Fasten the seat belt by pushing the latch into the buckle. Listen for an audible click.
3. Tug on the seat belt to make sure it is securely fastened. If the buckle unlatches, repeat this step. If the problem continues, replace the seat belt.

**WARNING:**

Before activating a Komfort Latch, make sure the amount of slack in the shoulder strap is set as described below. Excess slack in the shoulder strap reduces the effectiveness of the seat belt, and increases the risk of injury or death in an accident.

4. Snug the seat belt to your waist.
5. Position the shoulder strap diagonally across your chest with the adjustable D-loop bracket (if equipped). The shoulder strap must be centered on your shoulder and chest, away from your face and neck. See Fig. 287, [Proper Shoulder Strap Fit](#). If desired, engage the Komfort Latch or Sliding Komfort Latch as follows.

If equipped with a Sliding Komfort Latch, make sure that the shoulder strap is snug against your chest. Without loosening the shoulder strap, push the Sliding Komfort Latch switch to the "ON" position. See Fig. 285, [Sliding Komfort Latch](#). To activate the latch lean forward until you hear a click. This will allow for approximately 1 inch (2.5 cm) of slack between your chest and the shoulder harness. Once engaged, the latch will allow you to lean forward about 5 inches (13 cm) without having to reset the latch. Leaning forward more than 5 inches (13 cm) will disengage the Sliding Komfort Latch, requiring it to be reset.

If equipped with a Komfort Latch, pull on the shoulder strap to lessen the pressure of the strap on your shoulder and chest. Allow no more than 1 inch (2.5 cm) of slack between your chest and the shoulder harness. More slack can significantly reduce the seat belt effectiveness in an accident or a sudden stop. While holding the belt slack, press the Komfort Latch lever up, clamping the seat belt webbing (see Fig. 288, [Adjusting Shoulder Harness Clearance, Komfort Latch](#) and Fig. 289, [Locking the Komfort Latch](#)).

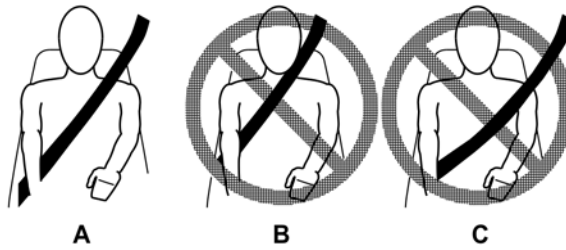

02/03/2017

f910634

A. Correct Belt is centered on your shoulder and chest, away from your face and neck.

B. Wrong Belt must not rub against face or neck.
C. Wrong Belt must not hang off shoulder.

Fig 287, Proper Shoulder Strap Fit

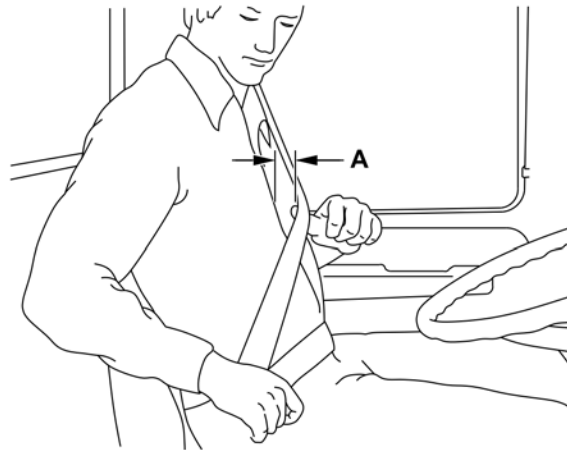

02/03/2017

f910048a

A. 1 Inch (2.5 cm) Maximum

Fig 288, Adjusting Shoulder Harness Clearance, Komfort Latch

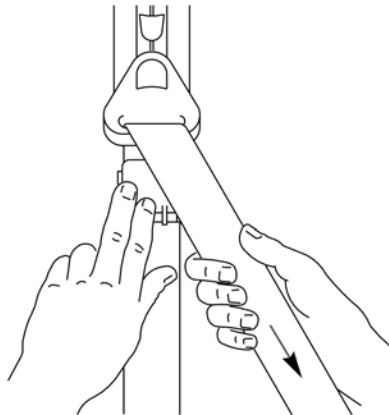

02/03/2017

f910144

Fig 289, Locking the Komfort Latch

- Unbuckle the seat belt and release the Komfort Latch or the Sliding Komfort Latch as follows.

If equipped with a Sliding Komfort Latch, unbuckle the seat belt, then tug on the shoulder belt to release the Sliding Komfort Latch, or press the Sliding Komfort latch to the OFF position, then unbuckle the seat belt.

If equipped with a Komfort Latch, unbuckle the seat belt, then release the Komfort Latch by giving the shoulder belt a quick tug. If you lean forward against the shoulder belt, the Komfort Latch will automatically release, and will need to be reset.

NOTE: Neither the Komfort Latch nor the Sliding Komfort Latch need to be manually released in an emergency situation. Each will release by itself under rough road or other abnormal conditions. Make sure the seat belt is completely retracted when it is not in use.

10.03 Sleeper Compartment Restraints

10.03.01 Adjustment of the Bunk Restraint



WARNING:

Keep the upper bunk folded up and locked, and do not use the sleeper compartment while the vehicle is in motion unless a bunk restraint is installed and used. Not using the bunk restraint increases the chance of injury, or the degree of injury, to all occupants of the vehicle from accidents or sudden stops.

- Make sure the belt is attached to the bunk support and sleeper wall.
- To lengthen the belt, tip the link end downward and pull the link until it connects with the buckle.
- After the belt is connected, shorten it by pulling on the loose end until the belt is snug, but comfortable. Be sure the belts are not twisted. See Fig. 290, [Bunk Restraint Adjustment](#).

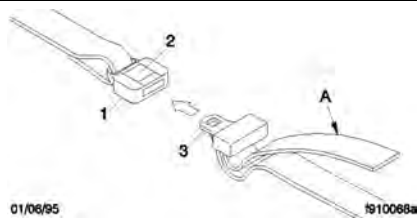

- A. Pull on the loose end to shorten the belt.
- Buckle

- Belt Release Button
- Link

Fig 290, Bunk Restraint Adjustment

10.03.02 Operation of the Bunk Restraint

**WARNING:**

Keep the upper bunk folded up and locked, and do not use the sleeper compartment while the vehicle is in motion unless a bunk restraint is installed and used. Not using the bunk restraint increases the chance of injury, or the degree of injury, to all occupants of the vehicle from accidents or sudden stops.

1. Starting at the foot of the bunk, pull the link end of the belt up far enough to engage the buckle. See Fig. 291, [Bunk Restraints](#).

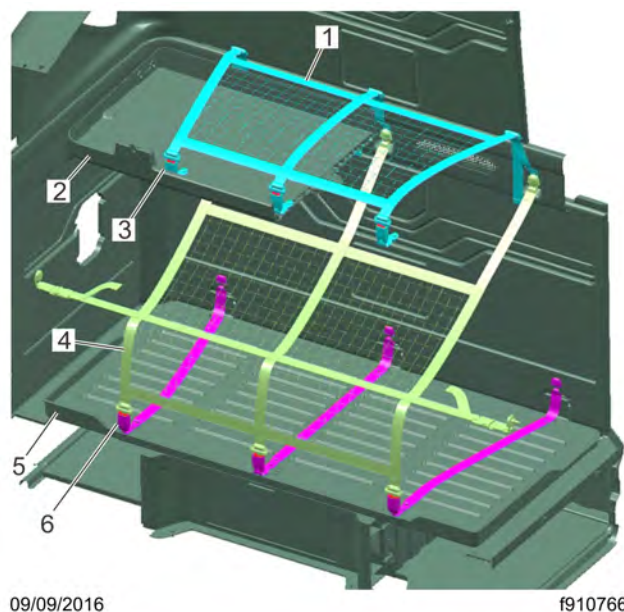

NOTE: Mattresses not shown for clarity. Upper bunk pan cutaway shown for clarity.

- | | |
|-------------------------|-------------------------|
| 1. Upper Bunk Restraint | 4. Lower Bunk Restraint |
| 2. Upper Bunk | 5. Lower Bunk |
| 3. Upper Bunk Buckle | 6. Lower Bunk Buckle |

Fig 291, Bunk Restraints

2. Fasten the belt by pushing the link end into the buckle until it latches. Make sure that the belt is not twisted. Check the engagement by trying to pull the link out of the buckle. If they come apart, repeat this step. If the problem continues, replace the belt. Repeat steps 1 and 2 for the other two belts located in the middle and upper portion of the bunk to lock the restraint in place.
3. To release the bunk restraint, push the release button on the buckle at the head of the bunk and pull the link from the buckle.

Repeat this step for the other two buckles to completely release the bunk restraint.

10.04 Steering Wheel Air Bag

10.04.01 Steering Wheel Air Bag

NOTE: Only vehicles with the letters "SRS" molded into the steering wheel center pad are equipped with a steering wheel air bag.

The air bag, when used with seat belts, provides additional protection to the driver in severe frontal collisions. Steering wheel air bags are designed to inflate only in severe frontal collisions. The driver and the passenger should always wear seat belts. The steering wheel air bag will activate during a collision even if the seat belts are not fastened, but the system is designed to provide protection to the occupant only when the seat belts are fastened.



WARNING:

Keep all heavy objects in the cab secured. Do not place objects on the steering wheel or between you and the steering wheel. Any such objects may cause harm during an accident. Keep your hands on the sides and lower portion of the steering wheel. Failure to follow these instructions may result in death or personal injury.

For maximum protection in a collision, always be in a normal seated position with your back against the seat back and your head upright. Fasten your seat belt and ensure that it is properly positioned on your body as described under the "Seat Belt Operation" heading. Since the air bag inflates with considerable speed and force, a proper seat position will help keep you a safe distance from the inflating air bag.

10.04.02 Inspection and Service



WARNING:

Do not attempt to service or modify the air bag system. Unintentional or improper air bag deployment could cause severe bodily injury or death. Contact an authorized Freightliner service facility for all service and maintenance.

The air bag system contains components that use combustible chemicals. Do not cut, drill, braze, solder, weld, strike, or probe the air bag components. Keep all liquids and chemicals away from air bag components.

The surface of the deployed air bag may contain small amounts of sodium hydroxide (which is a by-product of the gas generant combustion) and metallic sodium. Sodium hydroxide may be irritating to the skin and eyes. Immediately wash your hands and exposed skin areas with a mild soap and water. Flush your eyes immediately if exposed to sodium hydroxide.

The operational readiness of the air bag system is indicated by the supplemental restraint system (SRS) indicator on the dash. The SRS indicator illuminates for several seconds when the ignition is turned on, and then it goes off. The indicator will remain on if there is a problem with the air bag system. The vehicle should be serviced if the SRS indicator does not illuminate when the ignition is turned on, or if the SRS indicator remains on.

The air bag module may contain perchlorate material; for information, see www.dtsc.ca.gov/hazardouswaste/perchlorate. Special handling may apply; follow appropriate rules and regulations when disposing of materials.

For all service and maintenance, contact an authorized Freightliner service facility.

10.05 RollTek Rollover Protection System

10.05.01 Identification

Only seats with the RollTek module under the seat and the molded side-roll air bag cover on the upper side of the seat back are equipped with the RollTek rollover protection system; see Fig. 292, [RollTek Protection System Components](#). RollTek may be installed in one of the following configurations:

- driver seat only or driver and passenger seats
- driver seat only, with an optional steering wheel frontal air bag
- driver and passenger seats, with an optional steering wheel frontal air bag



10.05.02 RollTek System

The RollTek system, when used with seat belts, provides additional protection to the driver and passenger (if equipped with a passenger-side system) in rollover accidents. The RollTek system provides a significant increase in seat stability during a rollover. Vehicles equipped with RollTek rollover protection have a sensor mounted in the seat base that activates the side-roll air bag and seat pull-down device during a rollover.

When the RollTek module senses a rollover, the module triggers gas cylinders mounted in the base of the seat. The gas cylinders activate the power cinches that then tighten the lap and shoulder belts against the occupant of the seat and lower the seat suspension, moving the occupant down and away from the steering wheel and ceiling. The side-roll air bag deploys from the outboard side of the seat as the seat is pulled down to its lowest position. See Fig. 293, [Side-Roll Air Bag](#).

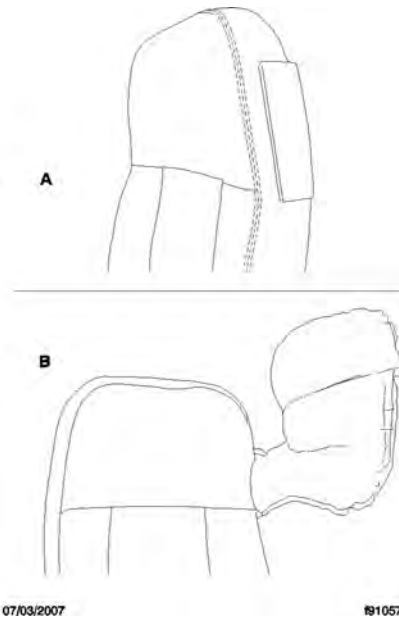

A. Side-roll air bag contained in seat.

B. Side-roll air bag deployed.

Fig 293, Side-Roll Air Bag

**WARNING:**

Always use the seat belts when operating the vehicle. Failure to do so can result in severe personal injury or death. Do not place infants and children in seats equipped with the RollTek system. The RollTek system is designed for adults only. Doing so could result in severe bodily injury or death. Keep all heavy objects in the cab secured. Do not place objects on the seat back or block the side-roll air bag. Objects that block the side-roll air bag may prevent proper inflation and could result in serious injury or death.

The RollTek system will activate during a rollover even if the seat belts are not fastened, but the RollTek system is only designed to provide protection to the occupant when the seat belts are fastened.

For vehicles with the RollTek system(s) only, device(s) deploy as follows:

- Rollover Crash occupant seat belt pretensioning, seat pretensioning, and side-roll air bag at the proper time
- Frontal Crash no devices deployed

For vehicles with the RollTek system(s) and frontal steering wheel air bag, device(s) deploy as follows:

- Rollover Crash occupant seat belt pretensioning, seat pretensioning, and side-roll air bag at the proper time
- Frontal Crash steering wheel air bag, occupant seat belt pretensioning, seat pretensioning, and the side-roll air bag at the proper time

| | |
|---|-----|
| 11.01 Windows | 328 |
| 11.02 Mirrors | 328 |
| 11.03 Cab Amenities | 329 |
| 11.03.01 Cup Holders | 329 |
| 11.03.02 Lighting | 330 |
| 11.03.03 Power Outlets | 330 |
| 11.03.04 Radio and CB | 330 |
| 11.03.05 Storage | 330 |
| 11.03.06 Universal Serial Bus (USB) Outlets | 332 |
| 11.04 Sleeper Amenities | 332 |
| 11.04.01 Sleeper Bunks | 332 |
| 11.04.02 Sleeper Curtain | 334 |
| 11.04.03 Baggage Compartment Doors | 334 |
| 11.04.04 Lighting | 334 |
| 11.04.05 Power Outlets | 334 |
| 11.04.06 Sleeper Access Door | 335 |
| 11.04.07 Sliding Side Window | 335 |

11. Cab and Sleeper Features

11.01 Windows

Power windows are standard on New Cascadia vehicles. The driver's door has two switches mounted in the top of the door, that control the driver and passenger windows separately. See Fig.294, [Door Switches \(driver-side shown\)](#). The passenger door has a switch mounted in the top of the door that controls the passenger-side power window.

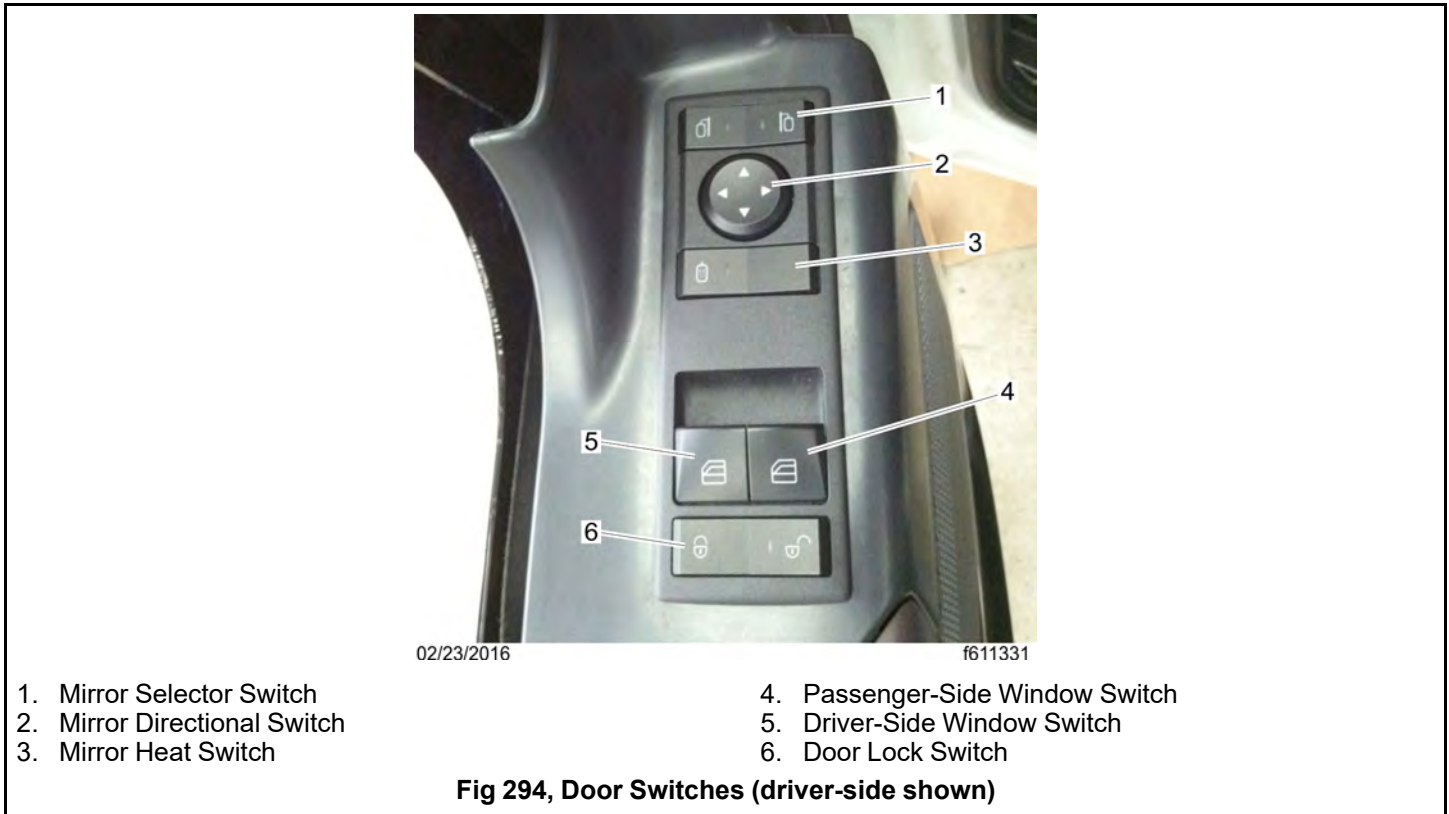

CAUTION:

There is no anti-pinch protection when the window is almost closed. Be sure to clear all objects from the window before closing.

The window switches have three positions: lower window, neutral, and raise window. Press forward on the switch to lower the window. Hold the switch down in the forward position for approximately one second to activate the express function; the window will continue to roll down after the switch is released. Press the switch in the rearward position (bump) to raise the window.

11.02 Mirrors

The standard outside mirrors are mounted on the door frame. The power mirrors are controlled with a left-hand or right-hand mirror selector switch, and a directional switch. Select the left (driver) mirror, or the right (passenger) mirror using the selector switch. The mirror can then be adjusted by pressing the directional switch arrow for the direction the mirror should be adjusted.

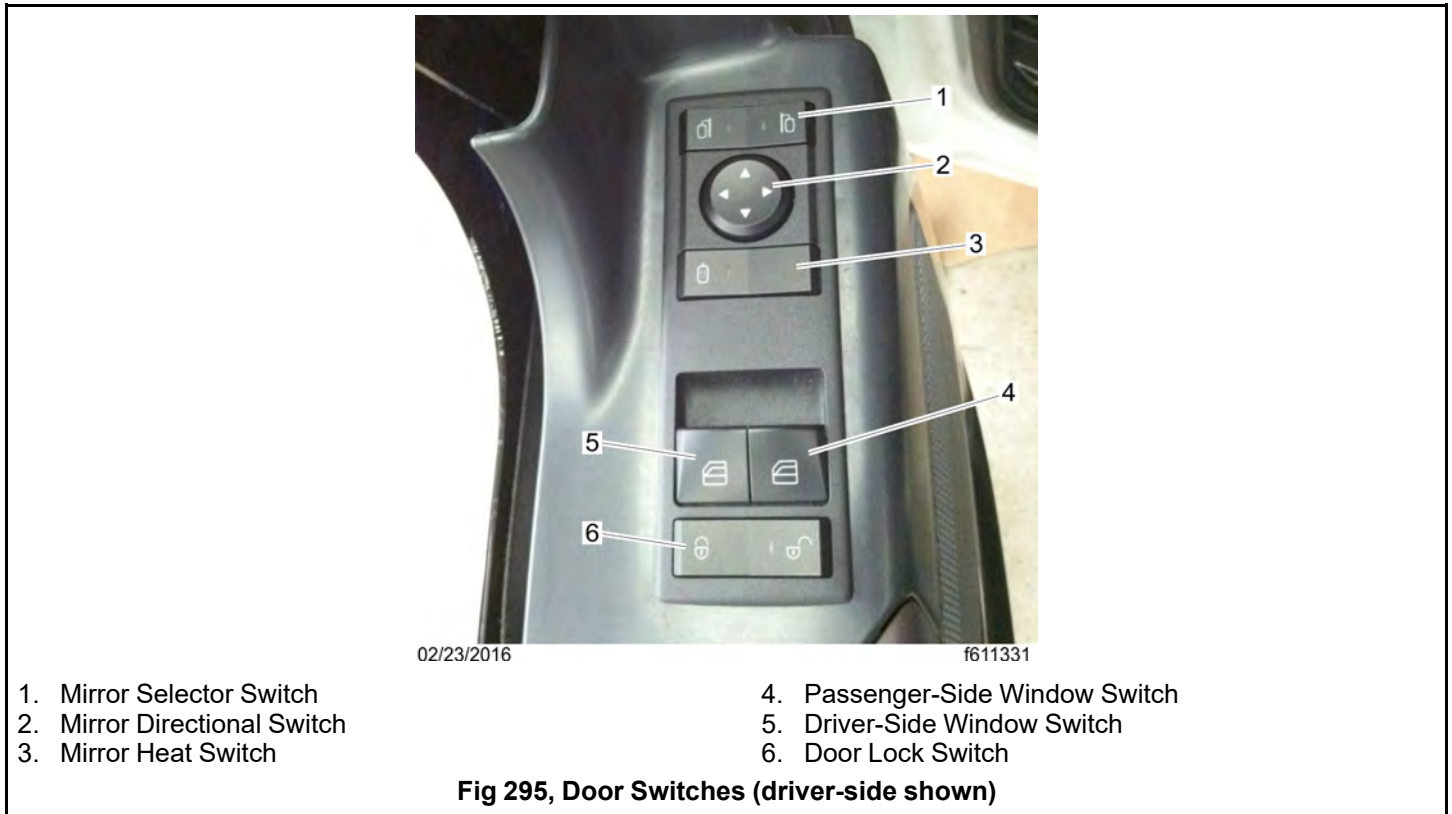

The outside door mirrors can be heated to keep them clear of fog, frost, and ice. To heat the mirrors, press the outboard part of the mirror heat switch on the door. See Fig.295, [Door Switches \(driver-side shown\)](#). When the mirror heat switch is on, an amber indicator light illuminates inside the switch. If the vehicle has Optimized Idle, mirror heating will not operate with the key in accessory mode, or if the Optimized Idle feature turns mirror heating off to reduce stress on the batteries. Refer to **Chapter 13** for more information.

11.03 Cab Amenities

11.03.01 Cup Holders

New Cascadia vehicles are available with many optional features. The following are some of those options.

Three cup holders and a map pocket are molded into the center dash. See Fig.296, [Dash Amenities](#). A removable ash cup is located in one of the cup holders.



05/03/2022

f611580

- | | |
|------------------|-----------------|
| 1. CB Tray | 4. Map Pocket |
| 2. USB Outlets | 5. Cup Holders |
| 3. Power Outlets | 6. Storage Tray |

Fig 296, Dash Amenities

11.03.02 Lighting

Vehicles are available with many optional features. The following are some of those options.

See the chapter on **Driver Controls** for detailed information regarding lighting controls.

11.03.03 Power Outlets

Vehicles are available with many optional features. The following are some of those options.

Two power outlets that supply 12V power for accessories are located on the dash switch panel. Optionally, three power outlets, or two power outlets and a cigarette lighter, are offered.

11.03.04 Radio and CB

Vehicles are available with many optional features. The following are some of those options.

The radio is mounted in the center dash panel. The CB is typically installed in the overhead console. An optional hot mount may be installed on top of the dash for fleet CB radios.

11.03.05 Storage

New Cascadia vehicles are available with many optional features. The following are some of those options.

Storage pockets are molded into the lower portion of the driver and passenger doors. A map pocket is located on the passenger side of the center dash. See Fig.297, [Dash Amenities](#).



05/03/2022

f611580

- | | |
|------------------|-----------------|
| 1. CB Tray | 4. Map Pocket |
| 2. USB Outlets | 5. Cup Holders |
| 3. Power Outlets | 6. Storage Tray |

Fig 297, Dash Amenities

Storage compartments are located in the overhead console, above the windshield and the cab doors. See Fig. 298, [Overhead Console](#). For compartments with doors, open the door by pulling outward on the latch. The doors are hinged at the top, and will swing upwards.



09/09/2016

f611449

1. Storage Compartment

2. CB Compartment

Fig 298, Overhead Console

11.03.06 Universal Serial Bus (USB) Outlets

Vehicles are available with many optional features. The following are some of those options.

Two USB outlets are located on the dash switch panel.

11.04 Sleeper Amenities

11.04.01 Sleeper Bunks

Sleepers are available with a number of optional features. The following are some of those options.

NOTE: See the chapter on **Climate Controls** for detailed information regarding sleeper climate controls.

NOTE: Make sure bunks are locked in place before sleeping or driving the vehicle.

Sleeper cabs can come with a lower bunk, an upper bunk, or both.

Lower bunk configurations include a bed with a storage compartment or, in 72 inch sleepers, a pull-down bed with two foldable seats and a table.

The release lever to unlock the storage bed is centered under the bunk. Press the lever to the right and pull up on the bunk to access the storage compartment. Pushing the bunk back into its original horizontal position will cause the bed latches to lock.

Setting up the pull-down bed (see Fig.299,[Pull-Down Bed With Lounge](#)) consists of the following steps.

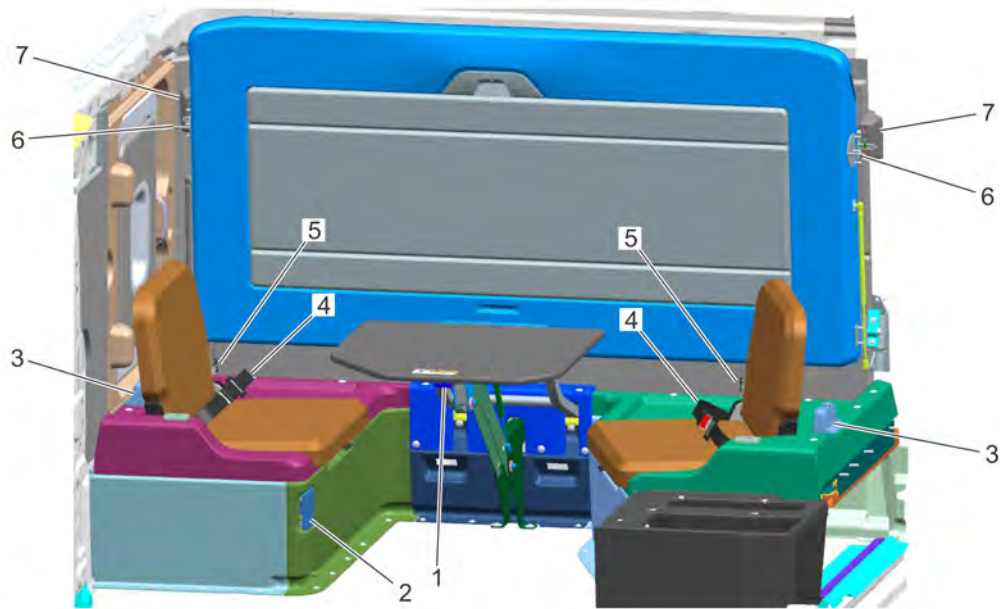

10/31/2019

f602720

- | | |
|--------------------------------|---|
| 1. Table T-Pull Handle | 5. Seat Latches |
| 2. Pull-Down Bed Release Latch | 6. Lower Bunk Latch Pins |
| 3. Lower Bunk Locks | 7. Upper Bunk Latch Pins Engaged in Upper Locks |
| 4. Seatbelts | |

Fig 299, Pull-Down Bed With Lounge

NOTE: To avoid damaging the upholstery, unlatch and move the seatbelts to the side before folding the chairs closed.

1. Pull forward on the seat latch while lowering the chair back toward the seat, and fold it down.
2. Pull the table t-pull handle forward, then push down on the top of the table until it is at the same level as the folded seats.
3. Pull out the bed release latch until you feel a release of tension. See item 2 in Fig.299,[Pull-Down Bed With Lounge](#).
4. Grasping the edge of the bed, pull it down until the lower latch pins engage in the lower bunk locks.

Setting up the lounge area consists of the following steps:

1. Pull out the bed release latch until you feel a release. See item 2 in Fig.299,[Pull-Down Bed With Lounge](#).
2. Holding the front edge, push the bed up toward the back wall until you hear or feel the upper latch pins lock into place.
3. Pull the t-handle and lift up on the table. As the table nears the correct height, the t-pull handle will be pulled back and lock into position. If this doesn't happen, reach under the raised table and push the t-pull handle in. Then gently push down to make sure the table is locked in the upright position.
4. To unfold each chair, push down on the seat latch while lifting the chair back.

Upper bunks fold up against and lock onto the cab back wall. To unlock and fold down an upper bunk, grasp the bunk release handle (see Fig.300,[Upper Bunk Release Handle](#)) and turn it to either the left or right and pull. To fold up and lock an upper bunk, turn the bunk release handle to the left or right and push up and back.



Fig 300, Upper Bunk Release Handle

11.04.02 Sleeper Curtain

Sleepers are available with a number of optional features. The following are some of those options.

NOTE: See the chapter on **Climate Controls** for detailed information regarding sleeper climate controls.

Sleeper curtains are included with all sleepers and work to block out light and help regulate temperatures in the sleeper compartment.

11.04.03 Baggage Compartment Doors

Sleepers are available with a number of optional features. The following are some of those options.

NOTE: See the chapter on **Climate Controls** for detailed information regarding sleeper climate controls.

The baggage compartment doors are intended as a convenient means to stow or remove items under the bunk. The baggage compartment doors can be opened from the inside by using the pull cable located near the rear edge of the cab door opening. Pull the cable handle labeled BAGGAGE forward to open the door.

IMPORTANT: The baggage compartment doors have two-stage latching. When closing the doors, ensure that they are completely latched to prevent wind noise and water intrusion.

11.04.04 Lighting

Sleepers are available with a number of optional features. The following are some of those options.

NOTE: See the chapter on **Climate Controls** for detailed information regarding sleeper climate controls.

NOTE: See the chapter on **Driver Controls** for detailed information regarding lighting controls.

Lighting controls in the sleeper control panel will control lights in the bunk area.

11.04.05 Power Outlets

Sleepers are available with a number of optional features. The following are some of those options.

NOTE: See the chapter on **Climate Controls** for detailed information regarding sleeper climate controls.

Power outlets are located underneath the lower bunk and/or the sleeper control panel. See Fig.301, [Sleeper Control Panel](#) for a typical sleeper panel with power outlets.



- | | |
|-----------------------------------|-----------------|
| 1. Inverter/Charger Display Panel | 3. Power Outlet |
| 2. Sleeper Climate Control Panel | 4. Clock |

Fig 301, Sleeper Control Panel

11.04.06 Sleeper Access Door

Sleepers are available with a number of optional features. The following are some of those options.

NOTE: See the chapter on **Driver Controls** for detailed information regarding sleeper climate controls.

The sleeper access door is not intended for entry or exit. The door is intended only as a convenient means to stow or remove personal belongings in the sleeper area. The sleeper access door can be opened from inside the cab using two different methods. The primary method is the pull cable located near the lower-rear edge of the cab door opening. Pull the cable handle labeled **ACCESS** forward to open the sleeper door. The secondary method is the black knob located at the upper rear edge of the sleeper door opening. Pull this knob down to open the sleeper door.

IMPORTANT: The sleeper access doors have two-stage latching. When closing the doors, ensure that they are completely latched to prevent wind noise and water intrusion.

11.04.07 Sliding Side Window

Sleepers are available with a number of optional features. The following are some of those options.

NOTE: See the chapter on **Driver Controls** for detailed information regarding sleeper climate controls.

The lower section of the sliding side window moves vertically and may be locked in multiple positions to suit. Two spring-loaded tabs are located at the top of the sliding section. To adjust the window, pull both tabs toward the center of the glass and move the sliding section to the desired height. Release the tabs to lock the sliding section.

| | |
|---|-----|
| 12.01 System Overview | 338 |
| 12.01.01 General Description, Electrical System | 338 |
| 12.01.02 The Instrumentation Control Unit (ICU) and Fault Codes | 338 |
| 12.02 Vehicle Power Distribution..... | 341 |
| 12.02.01 General Description, Vehicle Power Distribution | 341 |
| 12.02.02 Cab Electrical and Electronic Components..... | 344 |
| 12.03 Cab Load Disconnect Switch..... | 346 |
| 12.03.01 Cab Load Disconnect Switch, General Information | 346 |
| 12.03.02 Battery Contactor Control Board..... | 347 |
| 12.04 Emergency Power | 349 |
| 12.05 Powernet Management..... | 350 |
| 12.06 Optional Power Systems..... | 350 |
| 12.06.01 Shore Power..... | 350 |
| 12.06.02 Inverter/Charger..... | 350 |

12. Electrical System

12.01 System Overview

12.01.01 General Description, Electrical System

This vehicle has a multiplex electrical system. By transmitting multiple electronic messages through the same wire, a multiplex system reduces the number of interconnected wires, allows for more precise control of the electrical system, and makes it easier and quicker to diagnose electrical faults and add optional equipment.

In addition, the wiring harnesses are developed for the maximum number of options, meaning that space for additional wires is available within the wiring harness regardless of the number of optional features on the vehicle. This design provides a cleaner main harness and is meant to eliminate the need for wiring overlays.

Traditional power distribution devices are replaced with electronic control modules (ECUs). These coordinate power to outputs such as lighting, displays, gauges, and indicators and control power distribution by monitoring inputs such as sensors and switches. Power is supplied by the vehicle power distribution module (VPDM).

The ECUs also continuously monitor the status of all input devices and transmit messages over multiple control area networks (CANs), reducing the number of sensors required for operation.

12.01.02 The Instrumentation Control Unit (ICU) and Fault Codes

NOTE: Some non-critical faults may be suppressed and will not appear during an instrumentation control unit (ICU) self-check.

The majority of electrical and electronic issues on the vehicle will have an associated fault code, which will be displayed on the ICU.

If the ICU receives active fault codes during the ICU self-check, it displays them one after the other until the parking brake is released or the ignition is turned off. Once the parking brake is completely released, the ICU displays alerts until acknowledged. See Fig.302, [ICUC Active Faults Alert Screen](#). If there are no active faults, the ICU displays the home screen after the self-check completes.



Fig 302, ICUC Active Faults Alert Screen

When there is an active vehicle fault code, a popup will appear on the ICU message screen.

To access fault codes in the ICU:

1. Use the buttons on the left-hand steering wheel to navigate to the wrench icon and press OK.



08/25/2016

f611439

Fig 303, Electronic Control Unite (ECU) List in the ICUC

2. ECU's with active faults will have an exclamation point next to them. Use the down arrow to select the affected ECU from the list, then press OK.

Refer to the ECU acronyms list for the full names of acronyms on the ICU screen. See Table.32,[ICU Electronic Control Unit Acronyms](#).

3. Locate the code to troubleshoot from the list of active fault codes, then press OK to access the information screen. See Fig.304,[Information Screen for an Active Fault Code](#).

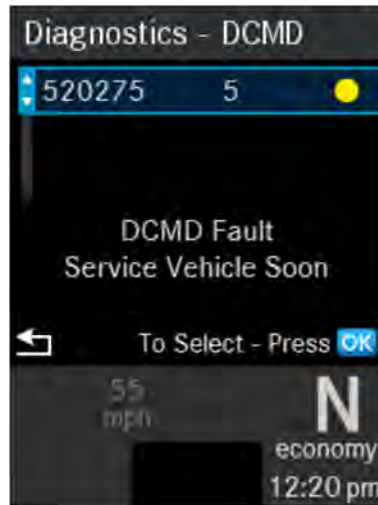

08/26/2016

f611442a

Fig 304, Information Screen for an Active Fault Code

4. Press OK again to access additional information. See Fig.305, [Additional Information for the Fault](#).

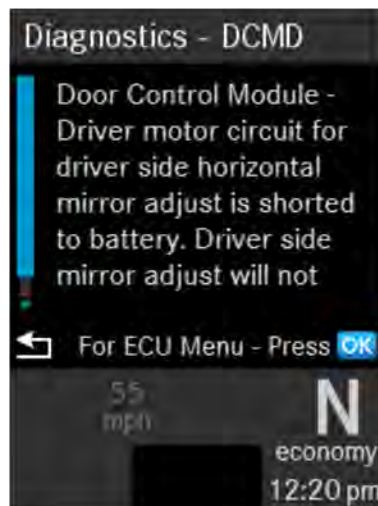

08/26/2016

f611443

Fig 305, Additional Information for the Fault

| ICU Electronic Control Unit Acronyms | | | |
|--------------------------------------|--|-------------|---|
| ABS | Antilock Brake System | ICU | Instrumentation Control Unit |
| ACM | Aftertreatment Control Module | MCM | Motor Control Module |
| CGW | Central Gateway | RDF | Radar Front End |
| CPC | Common Powertrain Controller | SAS | Steering Angle Sensor |
| DCMD | Door Control Module, Driver | SSAM | Single Signal Detect and Actuation Module |
| DCMP | Door Control Module, Passenger | TCM | Transmission Control Module |
| HVCF | Heating/Ventilation/AC Front (HVAC) | TPMS | Tire Pressure Monitoring System |
| HVCP | Heating/Ventilation/AC, Auxiliary (HVAC) | VRDU | Video Radar Decision Unit |

Table 31, ICU Electronic Control Unit Acronyms

12.02 Vehicle Power Distribution

12.02.01 General Description, Vehicle Power Distribution

The vehicle power distribution system provides battery power to the electrical and electronic systems.

The following components make up the vehicle power distribution system:

- Battery Cable Access (BCA)
- Vehicle Power Distribution Module (VPDM)
- Optional Cab Load Disconnect Switch (CLDS)

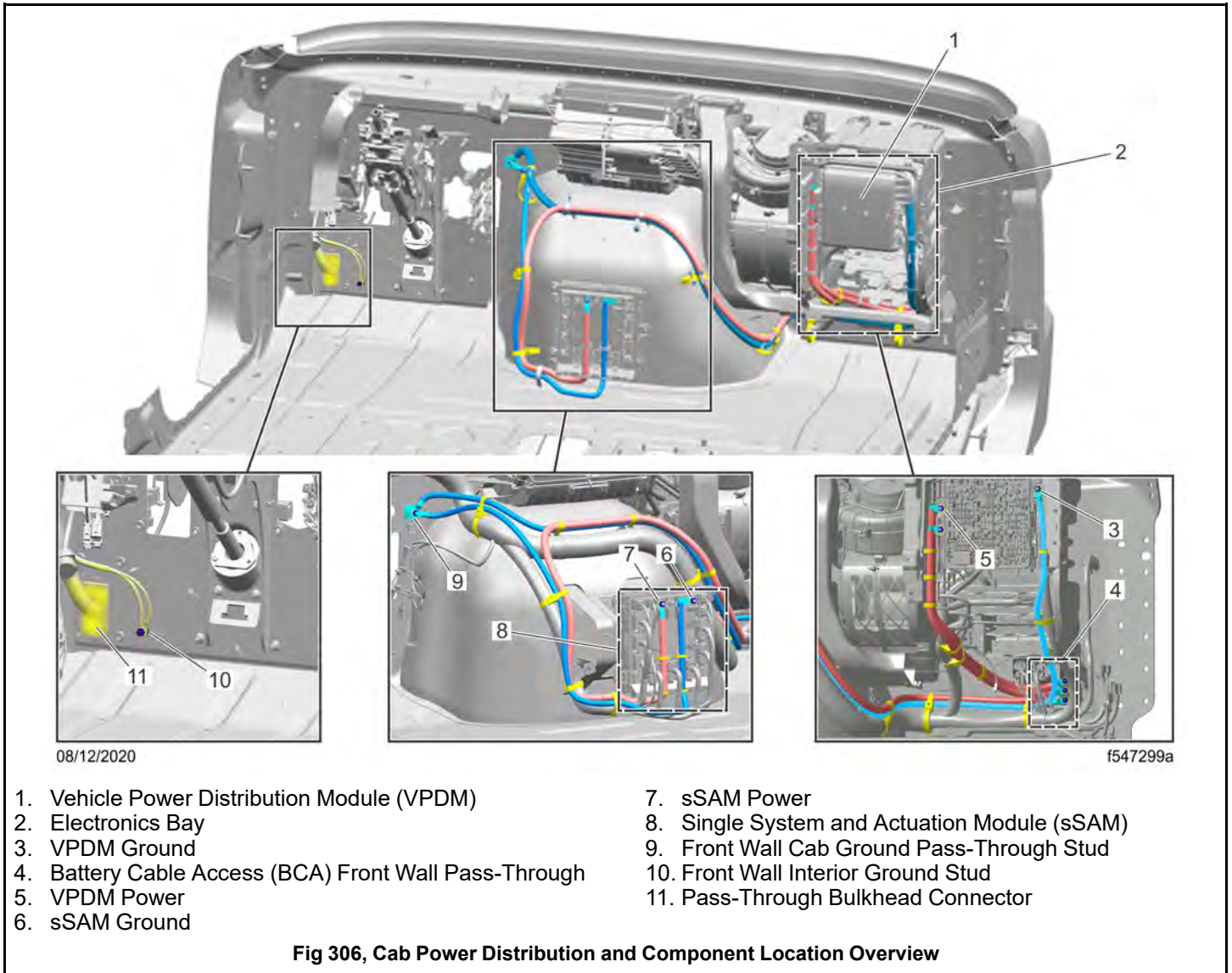

Vehicle power is supplied by the batteries to the battery cable access (BCA) box. The BCA front wall pass-through is the primary interface through which battery power gets transferred from outside the cab to the inside. It is located on the passenger side of the engine compartment front wall. See Fig.306, [Cab Power Distribution and Component Location Overview](#).

On vehicles equipped with an optional high current receptacle and/or optional inverter, the BCA will have circuit protection and power cables supplying those devices. Fuse locations will depend on the vehicle and will be outlined on a label on the BCA cover. For an example, see Fig.307, [Example Fuse Labeling on BCA Cover](#).

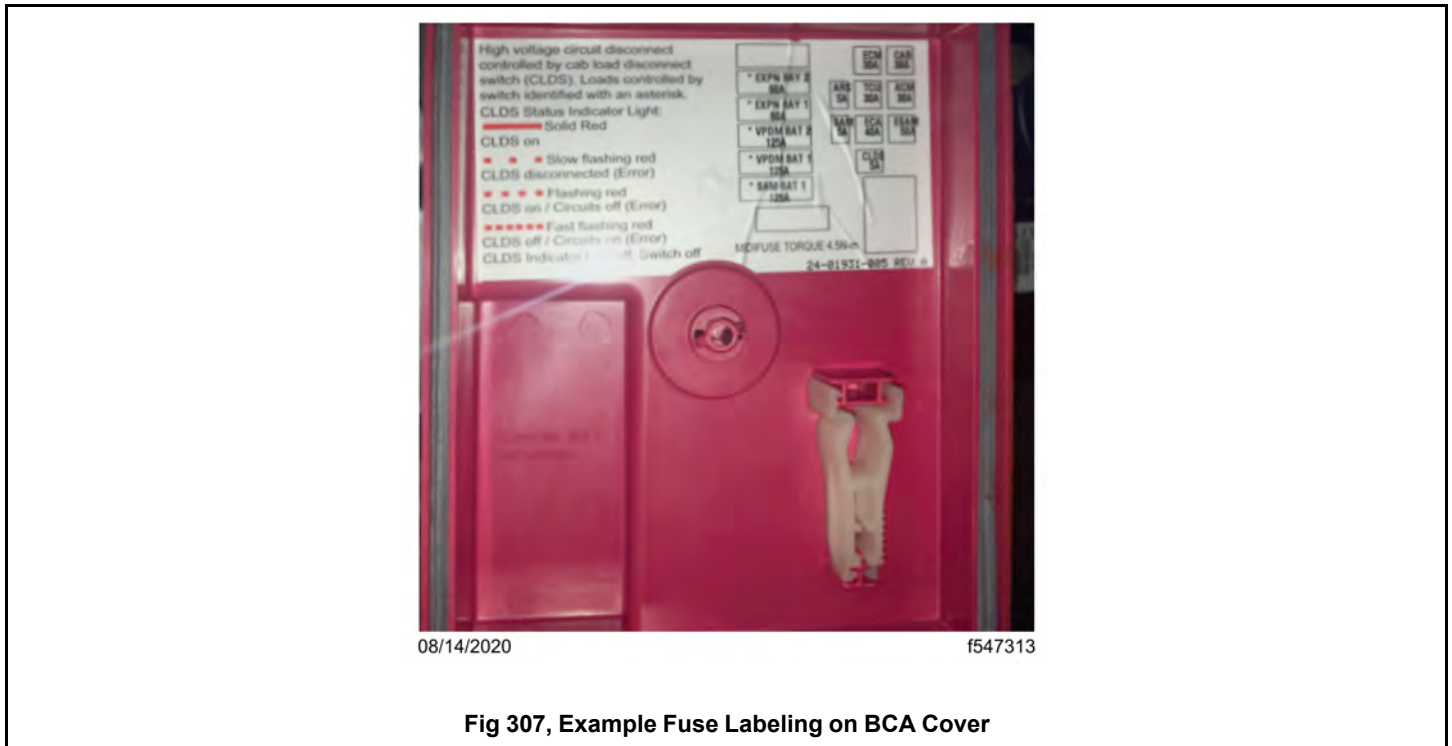

Fig 307, Example Fuse Labeling on BCA Cover

The power supplied by the batteries goes to the vehicle power distribution module (VPDM) and the Single System and Actuation Module (sSAM).

The VPDM is a fuse and relay power distribution box. It provides power and circuit protection for powertrain needs, cab functions, and various stand alone modules. It also supplies power to the emergency power supply circuits in the event of a module failure. The VPDM is located in the vehicle electronics bay, behind the passenger-side dash panel. See Fig. 306, [Cab Power Distribution and Component Location Overview](#).

Depending on a vehicle's specifications, the fuses and relays installed and their locations can vary. Each VPDM cover is illustrated with an image of the fuse and relay layout for that vehicle. See Fig. 308, [VPDM Inside Cover Map of Fuses and Relays](#) for an example of VPDM cover map of fuses and relays.



Both the VPDM and the sSAM are grounded at the cab-side front wall. See Fig. 306, [Cab Power Distribution and Component Location Overview](#).

On vehicles equipped with a cab load disconnect switch (CLDS), the BCA houses a contacting device that can open to shut off power to high current loads.

The cab load disconnect switch (CLDS) is an optional switch that can be used to open (turn OFF) or close (turn ON) circuits between the battery and the battery cable access box (BCA). It is described more fully later in this chapter.

12.02.02 Cab Electrical and Electronic Components

Pass-Through Bulkhead Connector

The pass-through bulkhead connector is where the interior dash harness connects to the exterior chassis harness. This provides a disconnect point for harness service, testing, and replacement. It is located on the driver-side front wall of the truck. See Fig. 309, [Cab Power Distribution and Component Location Overview](#).

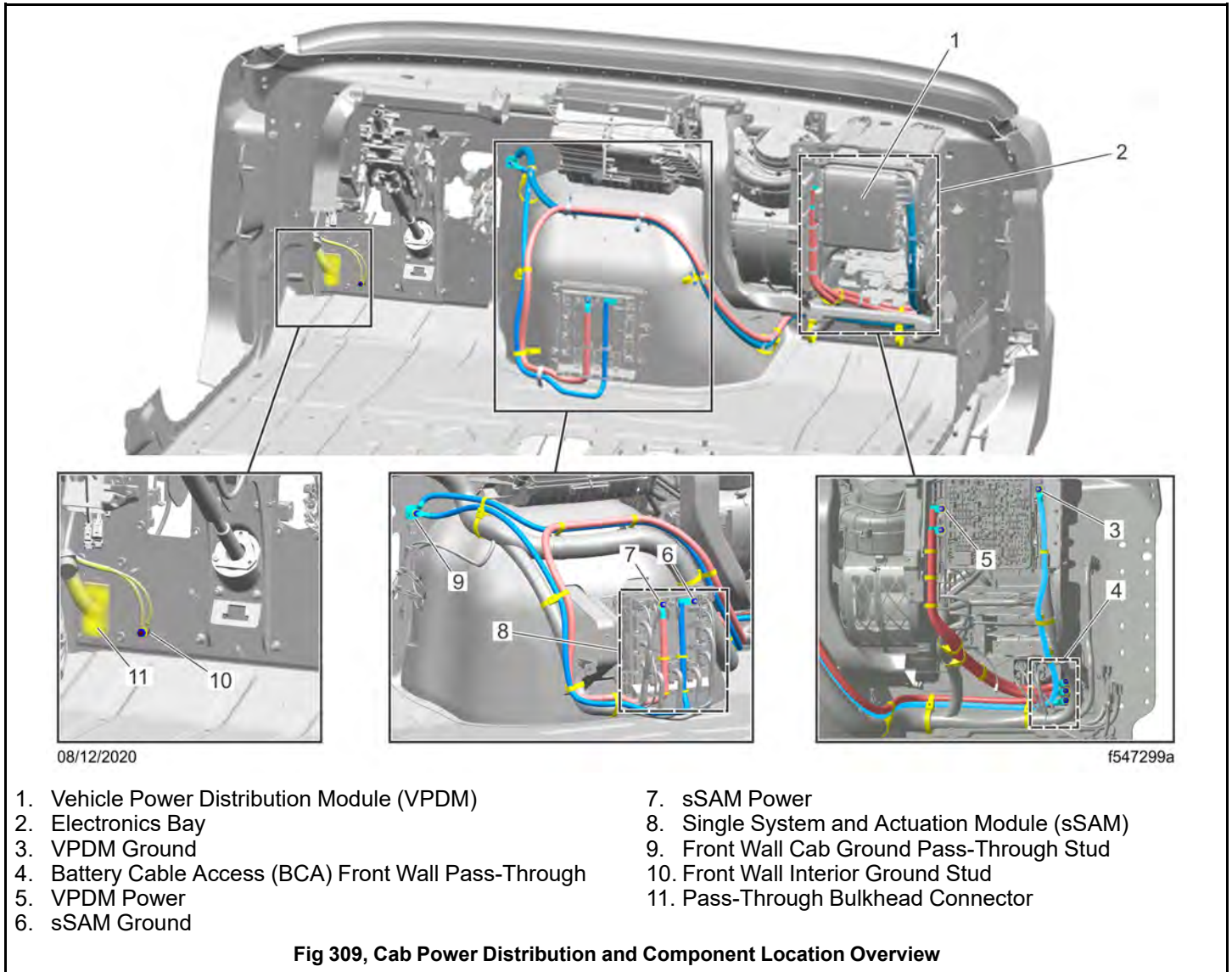

Single System and Actuation Module (sSAM)

The sSAM is the primary module in the electrical system, combining chassis power distribution, cab power distribution, and modular switch functions into a single ECU. The sSAM does **not** contain fuses or relays.

The sSAM reads input information from sensors, switches, and databus messages, and drives output and controller area network (CAN) messages. The sSAM is located near the center of the cab behind the lower dash panel. See Fig. 309, [Cab Power Distribution and Component Location Overview](#).

Electronics Bay

The electronics bay contains the electronic control units that control different vehicle features. It is located on the passenger-side of the cab behind the dash panel. See Fig. 309, [Cab Power Distribution and Component Location Overview](#) for its location in the cab and Fig. 310, [Electronics Bay](#) for the location of ECUs in the bay.

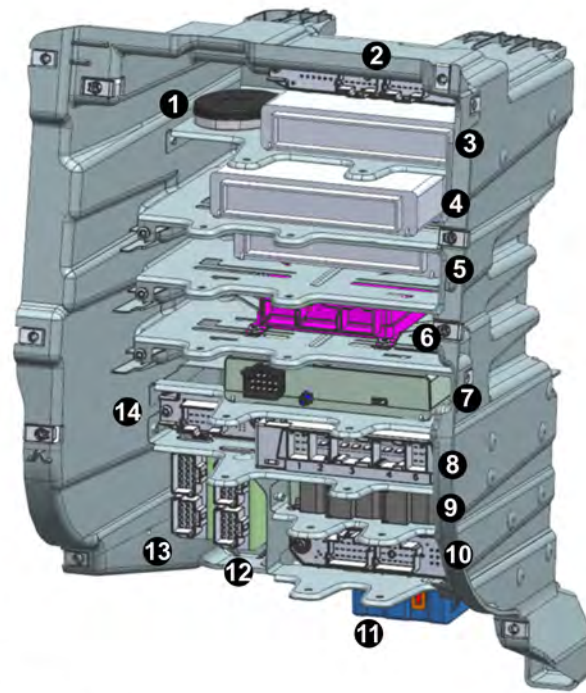

07/25/2016

f546313

NOTE: This figure shows almost all slots filled. In a typical vehicle, more electronics bay slots would be free.

- | | |
|---|--|
| 1. Truck Data Connect Antenna | 8. Common Powertrain Controller ECU |
| 2. Chassis CAN Starpoint Connector | 9. Antilock Braking System (ABS) ECU |
| 3. Common Telematics Platform | 10. Cabin CAN Starpoint Connector |
| 4. Expansion Module | 11. Central Gateway |
| 5. Expansion Module | 12. Video Radar Decision Unit (VRDU) ECU |
| 6. Electronically Controlled Air Suspension (ECAS) ECU | 13. Expansion Module |
| 7. Integrative Predicative Powertrain Control (IPPC) Module | 14. Powertrain CAN Starpoint Connector |

Fig 310, Electronics Bay

12.03 Cab Load Disconnect Switch

12.03.01 Cab Load Disconnect Switch, General Information



WARNING:

Turning the cab load disconnect switch (CLDS) to the off position does **not**

IMPORTANT: The ignition should be turned off before turning the cab load disconnect switch on or off.

NOTE: If parking the vehicle for more than two days, turn the cab load disconnect switch (CLDS) to the OFF position. If parking the vehicle for more than two days and the vehicle is not equipped with a CLDS, or if parking the vehicle for more than five days, disconnect the batteries. Even with the CLDS off, the vehicle draws a small amount of battery power. Disconnecting the batteries when parking the vehicle for extended periods prevents battery discharge and helps prolong battery life.

The cab load disconnect switch (CLDS) is an optional switch that can be used to open (turn OFF) or close (turn ON) circuits between the battery and the battery cable access box (BCA).

A vehicle in daily use would have the CLDS turned ON. When the CLDS is set to ON, a red LED indicator at the base of the switch selector illuminates. See Fig.311, [Cab Load Disconnect Switch](#).

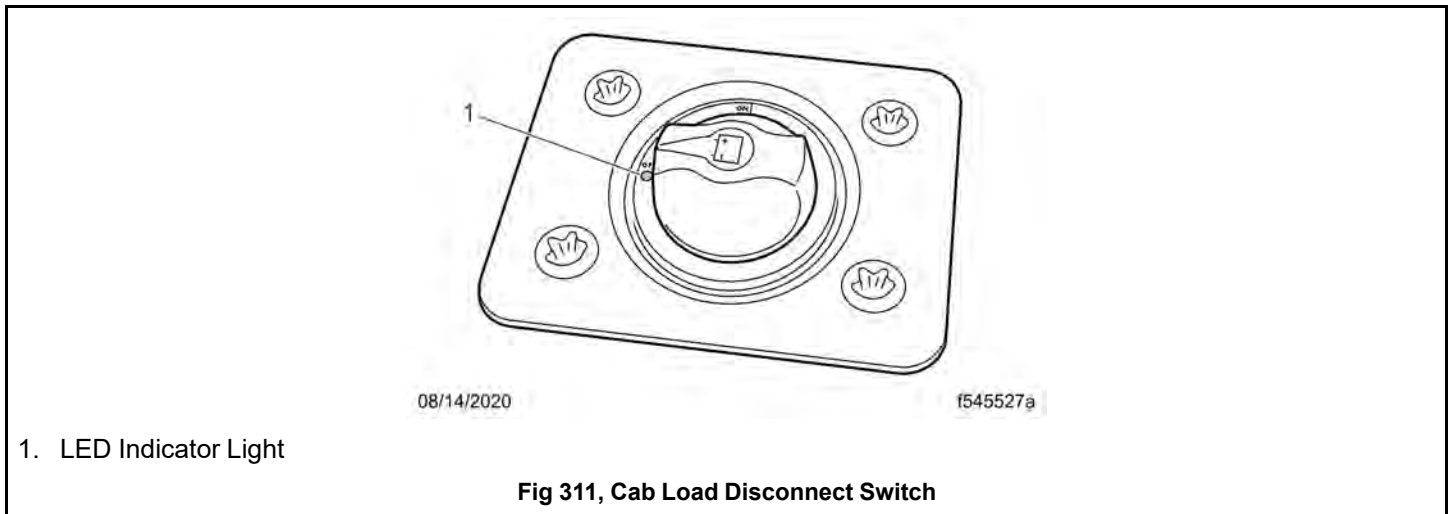

The CLDS should be set to OFF if the vehicle is going to be parked for more than two days. Turning the CLDS to OFF minimizes the power draw on the battery, preserving battery life and the ability of the vehicle to start after being parked for an extended period of time.

The CLDS may be mounted in a variety of location, including:

- inside the cab on the outboard side of the driver's seat;
- behind the cab on the driver's side;
- at the battery box;
- outside of the cab.

If the CLDS is turned to the off position while the vehicle is running, the emergency power system will activate. The power-train power distribution module will receive power from the emergency power feed, but the batteries will not be charging. See the section on **Emergency Power** for details about vehicle behavior under these conditions.

A flashing red LED indicates an error with the CLDS. Take the vehicle to an authorized service center for diagnostics and repair.

12.03.02 Battery Contactor Control Board

The optional battery contactor control board (CCB) is designed to cut power to high-current components when the cab load disconnect switch is in the OFF position. The battery contactor control board has an LED that reports the status of the cab load disconnect switch. See Fig.312, [Battery Cable Access Box \(engine side\)](#). Refer to Table. 33, [CLDS LED Status Menu](#) for LED status message explanations; this information will also be posted on a label inside the cover of the battery cable access box (see Fig.313, [Example Fuse Labeling on BCA Cover](#)).



05/26/2016

f546354

1. Cab Load Disconnect Switch Status LED

Fig 312, Battery Cable Access Box (engine side)



08/14/2020

f547313

Fig 313, Example Fuse Labeling on BCA Cover

| CLDS LED Status Menu | | |
|----------------------|------------|---------|
| Description | LED Status | Message |

Table 33, CLDS LED Status Menu

| | | |
|-------------------|-----|------------------------------|
| Solid red | ON | CLDS ON (normal operation) |
| Slow flashing red | ON | CLDS disconnected (error) |
| Flashing red | ON | CLDS ON/circuits OFF (error) |
| Fast flashing red | ON | CLDS OFF/circuits ON (error) |
| OFF | OFF | Power OFF |

Table 32, CLDS LED Status Menu

12.04 Emergency Power

NOTE: Emergency power mode is not available on vehicles built from September 2021 to the present. New Cascadia vehicles with CEEA+ architecture built before September 2021 may not exhibit the behaviors listed below when the emergency power circuit is active.



WARNING:

If emergency power is activated, do not shut down the engine until the vehicle is out of traffic and in a safe place. The engine will not be able to be restarted until the cause of the loss of power is corrected.

The emergency power circuit, formerly called 'Limp Home Mode,' allows a vehicle to be moved out of traffic and off the road in the event of a loss of power.

The emergency power circuit is live even when the cab load disconnect switch (CLDS) is turned off.

When the emergency power circuit is active, the vehicle will display varying behaviors depending on the cause of the loss of power:

- Windshield wipers may activate in vehicles built in or after 2018.
- Windshield wipers may activate in vehicles built before 2018 if the sSAM module and/or software has been upgraded.
- Gauges may become unresponsive or freeze.
- Switches may become inoperative.
- Warning lamps may display indicating low voltage and/or ECU faults.
- Different lamps on both or one side of the vehicle will come on and stay on.
- Different lamps on both or one side of the vehicle will start flashing.

Causes and their specific symptoms are detailed in the **New Cascadia Electrical Systems and Troubleshooting Manual**.

No matter the cause, the following lamps will remain constantly on:

- headlamps, low beams (either the left, right, or both)

No matter the cause, the following lamps will flash:

- front turn signals, left and right

Turning the ignition switch to OFF when in emergency power mode shuts down the exterior lighting, windshield wipers, and the engine. The engine will not start if the ignition switch is turned back to the ON position.

12.05 Powernet Management

The powernet management feature protects the batteries from excessive discharge by disconnecting certain loads features that draw power from the battery power supply. This allows the batteries to maintain enough of a charge to restart the vehicle.

Features that draw power are prioritized into different categories:

1. House loads: this includes the majority of dash and sleeper power outlets, sleeper reading and spot lamps, and sleeper auxiliary fans.
2. Basic loads: this includes power for fleet management systems and third party telematics as well as critical dash and sleeper power outlets.

By making noncritical features that draw power temporarily unavailable, powernet management allows the driver to continue using critical features.

Progressive low voltage disconnect (PLVD) is used to implement the powernet management feature.

PLVD calculates disconnecting loads based on battery voltage, ignition switch status, and engine rpm. When battery voltage drops below a predetermined value, house loads are turned off. One minute before house loads are turned off, a pop-up message will display in the ICU and an audible alarm will sound.

The front reading lamp, spot lamp, and sleeper lamps, designated as house loads can be turned back on after being shut-down by PLVD by pressing on the light or light switch.

No alarm sounds before basic loads are turned off.

A time delay is implemented for the shutdown and reactivation of loads to avoid unnecessary cycling when battery voltage is close to shutdown thresholds.

Loads disconnected by the PLVD will reconnect when all of the following conditions are met:

- ignition ON;
- engine at 450 rpm or above;
- batteries reach and maintain 12.7 volts for one minute.

12.06 Optional Power Systems

12.06.01 Shore Power

A 48" sleeper may be equipped with shore power; a 60" and 72" sleeper may be equipped with shore power and/or an optional inverter/charger.

Shore power provides the ability to connect to an external power source when parked by providing exterior power inlets. The 120 volts of alternating current provided can be used to power small appliances and electrical equipment without idling the engine.

A shore power system consists of one or two 120 volt power inlets on the exterior of the cab and, depending on the cab height, one to two power receptacles inside the cab. Sixty-inch and seventy-two inch raised roof sleeper cabs have two power receptacles; the forty-eight raised roof sleeper cab has one power receptacle.

An optional 120 volt indicator illuminates on the ICU when the shore power system is in use.

12.06.02 Inverter/Charger

A 48" sleeper may be equipped with shore power; a 60" and 72" sleeper may be equipped with shore power and/or an optional inverter/charger.

An optional 1500- or 1800-watt inverter/charger is available on 60" and 72" sleepers. An inverter converts the vehicle's battery power to 120 volts to provide electricity for small appliances and electrical equipment. It is located in the driver-side luggage compartment. See Fig.314, [Inverter/Charger](#). The unit has one three-pin GFIC OUT connector, one three-pin GFIC IN connector, and two AC power outlets.



Fig 314, Inverter/Charger



DANGER:

Do not store gasoline, flammable material, or any component with a connection to the fuel system in the storage compartment with the inverter/charger. The unit contains equipment that may produce sparks. Storing flammable or electrical equipment in proximity to the unit could result in fire or explosion hazards, which could result in serious injury or death.

The display on the sleeper control panel provides information about the operation of the unit. See Fig. 315, [Inverter/Charger Display Panel \(Xantrex Freedom\)](#) (Xantrex Freedom) or Fig. 316, [Inverter/Charger Display Panel \(Eaton\)](#) (Eaton). Refer to Table.34, [Display Panel Functions](#) for general control panel details.

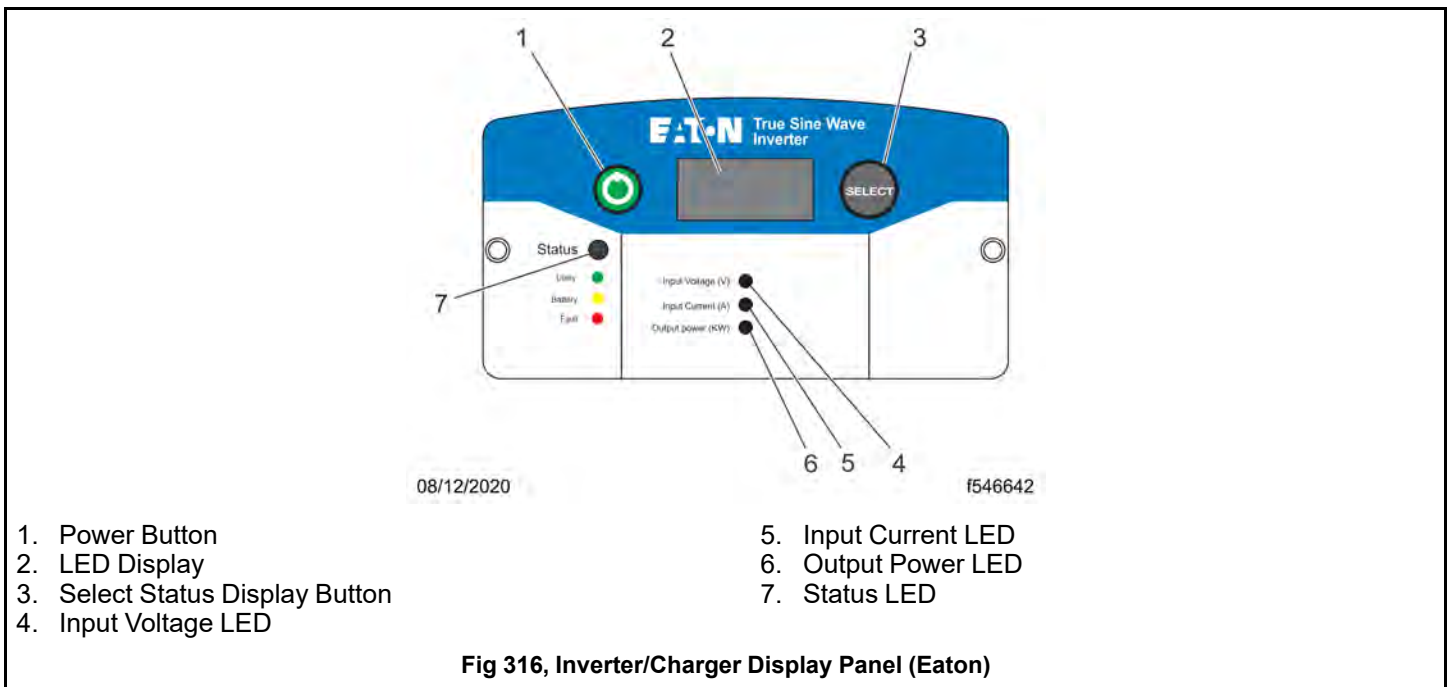
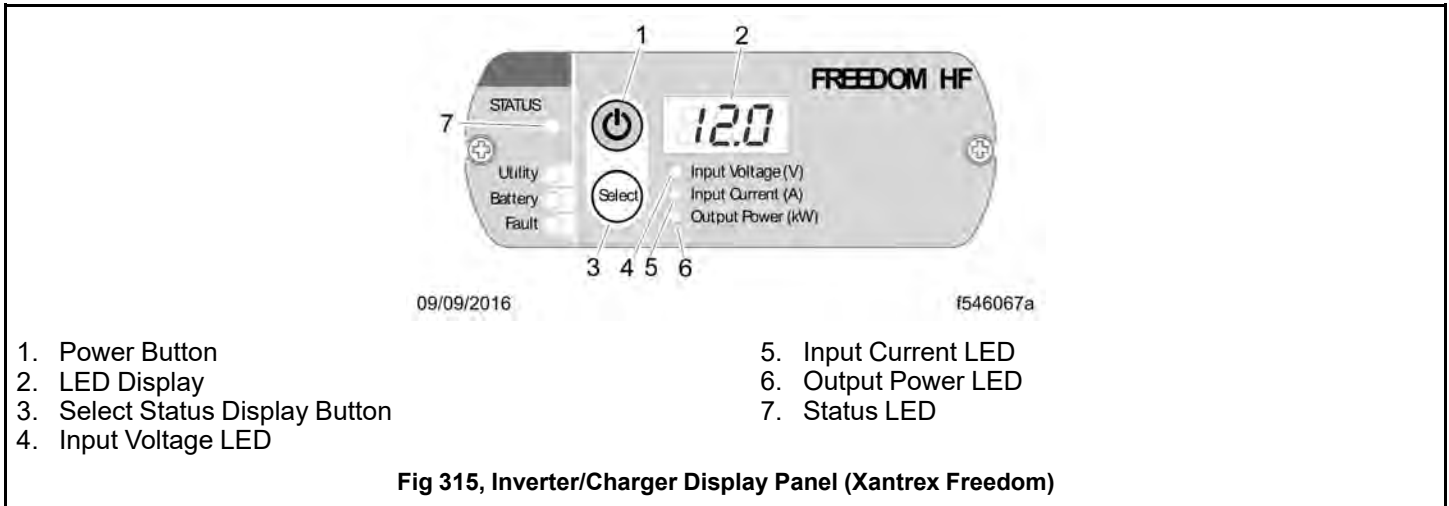

| Display Panel Functions | | |
|-------------------------|--------------|---|
| Number | Name | Function |
| 1 | Power Button | Press the power button for one second to turn the unit ON or OFF (when AC shore power is not present). Press and hold the button for five seconds to enter the Settings mode. Refer to the owner's manual for more information. |
| 2 | LED Display | The three digit LED display screen shows status information and fault codes. |

Table 34, Display Panel Functions

| Display Panel Functions | | |
|-------------------------|------------------------------|--|
| Number | Name | Function |
| 3 | Select Status Display Button | <p>The Select status display button changes the display or settings. Press the Select button to cycle through the setting options. Refer to the owner's manual for more information.</p> <ul style="list-style-type: none"> With the inverter mode ON, press the button to choose what appears on the LED display screen: Input Voltage, Input Current, or Output Power. An LED will illuminate next to the chosen mode. Details are provided below. <p>The unit is in "Inverter Mode" when shore power is not present and the unit is using the battery to power the appliances connected to it.</p> <ul style="list-style-type: none"> In an alarm condition, press and hold the button for two seconds to disable or enable the audible alarm. |
| 4 | Input Voltage LED | In inverter mode, when Input Voltage is selected, the corresponding LED will light up and the display will show the input voltage. |
| 5 | Input Current LED | In inverter mode, when Input Current is selected, the corresponding LED will light up and the display will show the input current. |
| 6 | Output Power LED | In inverter mode, when Output Power is selected, the corresponding LED will light up and the display will show the output power. |
| 7 | Status LED | <p>The Status LED indicates the unit's mode of operation through the display of one of three colored lights that</p> <ul style="list-style-type: none"> Green: Utility (Shore Power Mode) A solid green light indicates that the battery is fully charged. A flashing green light indicates that the unit is charging the battery. Yellow: Battery (Inverter Mode) A solid yellow light indicates that the unit is using the battery to supply AC power. A flashing yellow light indicates that the unit is in inverter mode, but AC shore power is detected and the unit is transferring to shore power mode within 20 seconds. Red: Fault Condition. <p>Refer to the owner's manual for fault code information and troubleshooting procedures.</p> |

Table 33, Display Panel Functions

For more information about troubleshooting, settings, and other features, refer to the owners manual included with the inverter/charger.

| | |
|--|-----|
| 13.01 Engine Starting | 356 |
| 13.01.01 General Description, Engine Starting | 356 |
| 13.01.02 Cold-Weather Starting | 358 |
| 13.01.03 Starting After Extended Shutdown | 358 |
| 13.02 Engine Operation | 358 |
| 13.02.01 Safety and Environmental Considerations | 358 |
| 13.02.02 Engine Break-In | 359 |
| 13.02.03 Normal Operation | 359 |
| 13.02.04 Cold-Weather Operation | 360 |
| 13.02.05 High-Altitude Operation | 361 |
| 13.03 Engine Shutdown | 361 |
| 13.04 Engine Protection Warning and Shutdown | 361 |

13. Engine Starting, Operation, and Shutdown

13.01 Engine Starting

13.01.01 General Description, Engine Starting

This engine chapter is to serve as a guide for best practices only. Each engine model may have operating characteristics that are unique to that particular engine, and will be documented in the engine manufacturer's literature. Always refer to specific instructions and recommendations from the engine manufacturer.

NOTE: Before starting the engine, see [4.01.01 General Description](#), **Instruments**, and see [5.01 Ignition Switch](#), **Driver Controls**. Read the engine manufacturer's operating instructions before starting the engine.

**WARNING:**

Never pour fuel or other flammable liquid into the air inlet opening in the air intake in an attempt to start the vehicle. This could result in a flash fire causing serious personal injury or property damage.

IMPORTANT: This vehicle is equipped with starter interlocks to enhance reliability and safety. Anti-grinding, starter pinion, and thermal protection logic limit the amount of time and conditions for starter engagement. Cranking may be limited from 5 to 15 seconds, with a 30 second cool-down period, as determined by the protection logic. If the engine is turning, the starter will not engage. Depending on the transmission option, the starter will not engage if the clutch is not fully depressed, or if the transmission is not in neutral.

IMPORTANT: The starter **can not** be used for priming the fuel system. If the fuel/water separator filter is replaced, and the fuel system needs to be primed, see the engine manufacturer's operating instructions.

1. Before engine start-up, complete the pre- and post-trip inspections and maintenance procedures, see [26.01 Safety Precautions](#).
2. Set the parking brake.
3. Place the transmission in neutral. On vehicles with manual transmissions, fully depress the clutch pedal.

NOTE: Depending on local jurisdictional emissions regulations, vehicles and/or engines that are domiciled outside of the U.S. and Canada may not be equipped with the STARTER BLOCKED function.

4. Turn the ignition switch to the ON position and allow the self-check to complete. See Fig.317, [Ignition Switch](#).

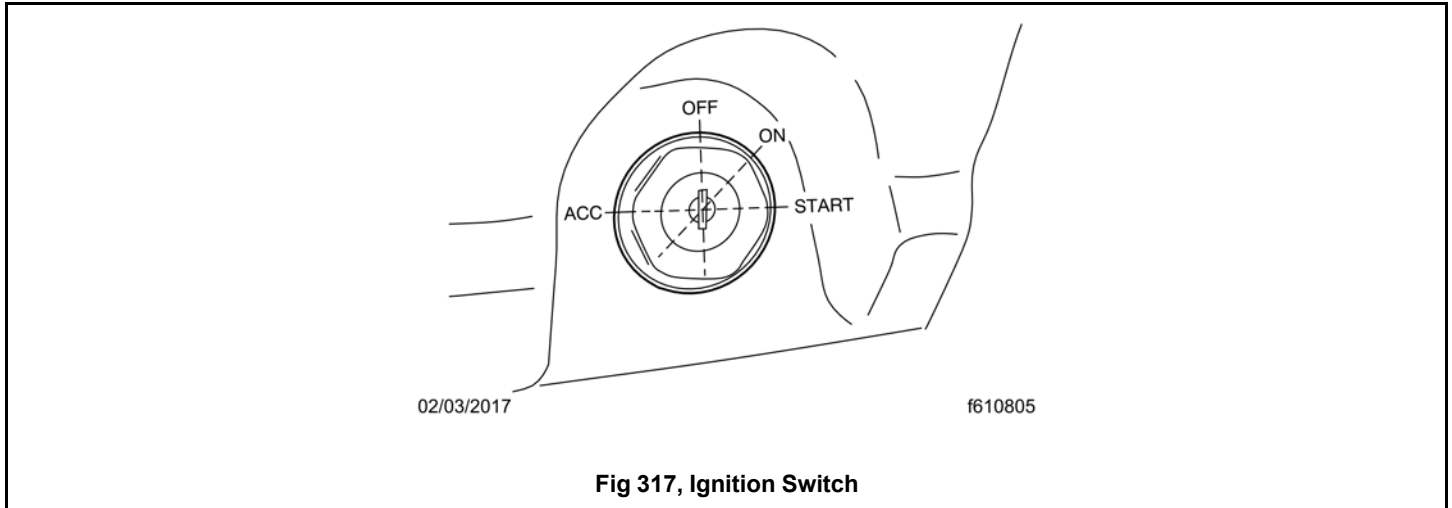

NOTE: The driver display screen may present a STARTER BLOCKED message if the gauge sweep is not completed, the transmission is in gear, or the starter has overheated.

5. Once the gauge sweep has completed, turn the ignition key to the START position. Release the key the moment the engine starts.

If the vehicle is equipped with an engine start switch (see Fig.318, [Engine Start Switch](#)), hold the switch down while turning the ignition key to the START position. Release the switch and the key the moment the engine starts.

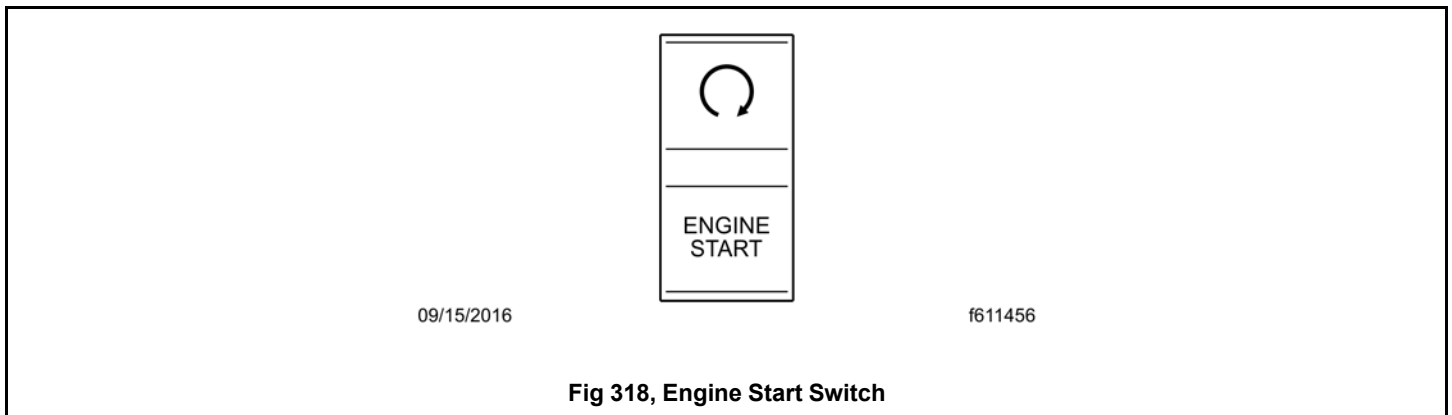

NOTICE:

Do not rev the engine if the oil pressure gauge indicates no oil pressure. Shut down the engine if oil pressure does not build within approximately ten seconds. Check to determine the cause of the problem. Operating the engine with no oil pressure will damage the engine.

6. It is not necessary to idle the engine before engaging or starting the operation, but load should be applied gradually during the warm-up period until the oil temperature reaches 140°F (60°C).

7. Apply load gradually during the warm-up period.

**NOTICE:**

If the oil pressure gauge indicates no oil pressure, shut down the engine within approximately ten seconds to avoid engine damage.

8. Check the oil pressure gauge for any drop in lubricating oil pressure or mechanical malfunction in the lubricating oil system. Minimum oil pressure at idle is 7 psi (48 kPa).

13.01.02 Cold-Weather Starting

See the engine manufacturer's operation manual for starting aids that are approved for specific engines.

13.01.03 Starting After Extended Shutdown

Before engine start-up, complete the engine pre-trip inspections, see [26.01 Safety Precautions](#).

**NOTICE:**

Failure to eliminate water-diluted lubricating oil may lead to serious engine damage at startup.

An engine in storage for an extended period of time (over winter, for example) may accumulate water in the oil pan through normal condensation of moisture on the internal surfaces of the engine. Oil diluted by water cannot provide adequate bearing protection at start-up. For this reason, change the engine oil and filters after extended storage.

13.02 Engine Operation

13.02.01 Safety and Environmental Considerations

**WARNING:**

Do not operate the engine in an area where flammable vapors such as gasoline or diesel fumes are present. Shut off the engine when in an area where flammable liquids or gases are being handled. Failure to observe these precautions could result in serious injury or death.

All engines on Freightliner vehicles comply with the requirements of the Federal (U.S.) Clean Air Act. Once an engine is placed in service, the responsibility for meeting both state and local regulations is with the owner/operator.

IMPORTANT: Depending upon local jurisdictional emissions guidelines, vehicles that are domiciled outside of the U.S. and Canada may not have engines and/or emissions aftertreatment systems that are compliant with current emissions regulations.

**NOTICE:**

It is extremely important that the following guidelines be followed for engines that comply with EPA07 or newer regulations, or damage may occur to the aftertreatment device, and the warranty may be compromised.

- Use ultralow-sulfur diesel with 15 ppm sulfur content or less.
- Do not use fuel blended with used engine lube oil or kerosene.
- Use only approved engine lube oil. For lists of engine oils approved for Detroit Diesel engines, refer to the Engine Operator Manual, accessible on Lubricants, Fuels & Coolants on the DTNA Portal. For third party engines, please refer to the engine manual.

A Top Tier compliant fuel is recommended. Look for the symbol that denotes a Top Tier compliant fuel; see Fig. 319, [Top Tier Fuel Symbol](#).



Fig 319, Top Tier Fuel Symbol

Adequate maintenance of the engine and the diesel particulate filter (DPF) are the responsibility of the owner/operator, and are essential to keep the emission levels low. Good operating practices, regular maintenance, and correct adjustments are factors that will help keep emissions within the regulations.

The driver should be familiar with the vehicle warning system in order to bring the vehicle to a safe stop if the engine malfunctions. If the driver doesn't understand how the warning system works, an engine shutdown could occur, causing a safety hazard. See [14.01.01 Idle Shutdown Timer](#) for more information.

13.02.02 Engine Break-In

Each engine must pass a full-load operating test on a dynamometer before shipment, thereby eliminating the need for a break-in. Before running the engine for the first time, follow the instructions in the manufacturer's engine operation manual.

13.02.03 Normal Operation

**WARNING:**

Do not operate the engine in an area where flammable vapors such as gasoline or diesel fumes are present. Shut off the engine when in an area where flammable liquids or gases are being handled. Failure to observe these precautions could result in serious injury or death.

Every engine has an operating range in which it performs most efficiently. The operating range extends from maximum torque rpm at the low end, to engine rated speed at the high end. Most engines deliver best fuel economy when operated in the low- and mid-speed segments of the efficiency range and produce maximum horsepower at rated speed, which is also the recommended maximum speed of the engine. For further engine-specific information, refer to the engine manufacturer's operation manual.

Prolonged idling of engines is not recommended, and is illegal in some states. Idling produces sulfuric acid that is absorbed by the lubricating oil, and eats into bearings, rings, valve stems, and engine surfaces. If you must idle the engine for cab

heating or cooling, use the high idle function of the cruise control switches. An idle speed of 900 rpm should be enough to provide cab heat in ambient temperatures that are above freezing.

If the engine is programmed with an idle shutdown timer, 90 seconds before the preset shutdown time, the CHECK engine light will begin to flash at a rapid rate. If the position of the clutch pedal or service brake changes during this final 90 seconds the idle shutdown timer will be disabled until reset.

13.02.04 Cold-Weather Operation

Satisfactory performance of a diesel engine operating in low ambient temperatures requires modification of the engine, surrounding equipment, operating practices, and maintenance procedures. The lower the temperature, the greater the amount of modification required. For service products approved for use in cold weather for your engine, see the engine manufacturer's engine operation manual.

If satisfactory engine temperature is not maintained, maintenance costs will increase due to greater engine wear. If the engine coolant gets too cold, raw fuel will wash the lubricating oil off the cylinder walls and dilute the crankcase oil, causing all moving parts of the engine to suffer from poor lubrication.

If the engine is in good mechanical condition and the precautions necessary for cold-weather operation are taken, ordinary cold weather will not cause difficulty in starting or loss of efficiency.

The following points are important to observe when operating in cold weather.

- Check for cracks in the battery cases, for corrosion of the terminals, and for tightness of the cable clamps at the terminals.
- Charge the batteries to full capacity. Replace damaged batteries.
- If equipped, turn off the load disconnect switch after the engine is shut down to prevent battery discharge.
- Have the alternator output checked at an authorized Freightliner service provider.
- Check the condition and tension of the drive belts.
- Refer to the engine manufacturer's operation manual for recommended heaters, low-viscosity lubricating oils, winter-grade fuels, and approved coolants.
- Periodically check the coolant mixing ratio (concentration of antifreeze in the coolant). Add more if necessary.
- At outside temperatures below -4°F (-20°C), a coolant preheater is recommended.

**NOTICE:**

For Detroit engines (EPA07 and newer), use of a winterfront is not recommended, as it can cause false fault codes with the engine and aftertreatment system, and possible emission component failures.

If using a winterfront, leave at least 25% of the grille opening exposed in sectioned stripes that run perpendicular to the charge-air-cooler tube-flow direction. This assures even cooling across each tube, and reduces header-to-tube stress, and possible chance of component failure. For engine-specific guidelines, see below:

Cummins engines: A winterfront may be used to improve cab heating while idling, and only when the ambient temperature remains below 10°F (-12°C).

Detroit engines: Use of a winterfront is not recommended. Using a winterfront can cause excessive fan run time, increased fuel consumption, and failure of the DEF system heaters to operate correctly, resulting in fault codes, poor performance, and power reduction. A winterfront should only be used temporarily in the following situations:

- To improve cab heating while idling in an extremely cold ambient temperature;
- When the ambient temperature remains below -22°F (-30°C) and the engine is unable to maintain a running coolant temperature of 175°F (80°C) during normal over-the-road operation.

13.02.05 High-Altitude Operation

Engines lose horsepower when operated at high altitude because the air is too thin to burn as much fuel as at sea level. This loss equals about three percent for each 1000 ft (300 m) altitude above sea level for a naturally aspirated engine.

All engines used on Freightliner vehicles are altitude-compensated by the use of a turbocharger. This reduces smoky exhaust at high altitudes, requires less downshifting, and allows the engine to make better use of its fuel. Nevertheless, shift gears as needed to avoid excessive exhaust smoke.

13.03 Engine Shutdown

NOTE: If parking the vehicle for more than two days, turn the cab load disconnect switch (CLDS) to the OFF position. If parking the vehicle for more than two days and the vehicle is not equipped with a CLDS, or if parking the vehicle for more than five days, disconnect the batteries. Even with the CLDS off, the vehicle draws a small amount of battery power. Disconnecting the batteries when parking the vehicle for extended periods prevents battery discharge and helps prolong battery life.

1. With the vehicle stopped, set the parking brake and place the transmission in neutral.

**NOTICE:**

Idle the engine one to two minutes before shutting it down. After hard operation, shutting down the engine without idling may cause damage to the turbocharger.

2. Allow the engine to idle one to two minutes before shutting it down. This allows the lubricating oil and the coolant to carry heat away from the combustion chambers, bearings, shafts, and seals.
3. Turn off the ignition switch and shut down the engine.

13.04 Engine Protection Warning and Shutdown

The driver should be familiar with the vehicle warning system in order to bring the vehicle to a safe stop if necessary. If the driver doesn't understand how the warning system works, the driver may not be able to utilize the advantage of the advance warning system to pull over appropriately.

The engine will begin a warning and derate and/or shutdown process if the engine coolant temperature, coolant level, engine oil pressure, or exhaust aftertreatment system (ATS) reach preset levels. On some engines, the warning process will begin when the engine oil temperature, engine coolant temperature, or the intake air temperature reach preset levels. Detroit engines may also begin the warning and shutdown process if water is detected in the fuel.

See the engine manufacturer's operation manual for specific details for your vehicle. See [15.01 Greenhouse Gas Emissions and Fuel Consumption Standards](#) for the warning and shutdown modes associated with the ATS.

Electronic engine protection can be specified as either SHUTDOWN or WARNING and DERATE.

**WARNING:**

When the STOP engine or CHECK engine lamp illuminates, most engines are programmed to shut down automatically within 30 seconds. The driver must immediately move the vehicle to a safe location at the side of the road to prevent causing a hazardous situation that could cause bodily injury, property damage, or severe damage to the engine.

In SHUTDOWN mode, the red STOP engine lamp will illuminate when the problem is serious enough to reduce power or speed. See Fig.320, [Engine Warning Lamps](#). Engine power will ramp down, then the engine will shut down if the problem continues while in derate mode. The driver has 30 or 60 seconds (depending on the critical fault type) after the STOP engine lamp illuminates to move the vehicle safely off the road. If the vehicle cannot be moved to a safe location within that time, turn the ignition switch to OFF for at least five seconds, then restart the engine. Repeat this action until the vehicle is safely off the road.

NOTE: In addition to the warning lamp, the driver display screen will present a warning message when the engine is in SHUTDOWN mode. See Fig.321, [Shutdown Alert](#). For vehicles with Detroit engines only, the time remaining before shutdown is displayed.

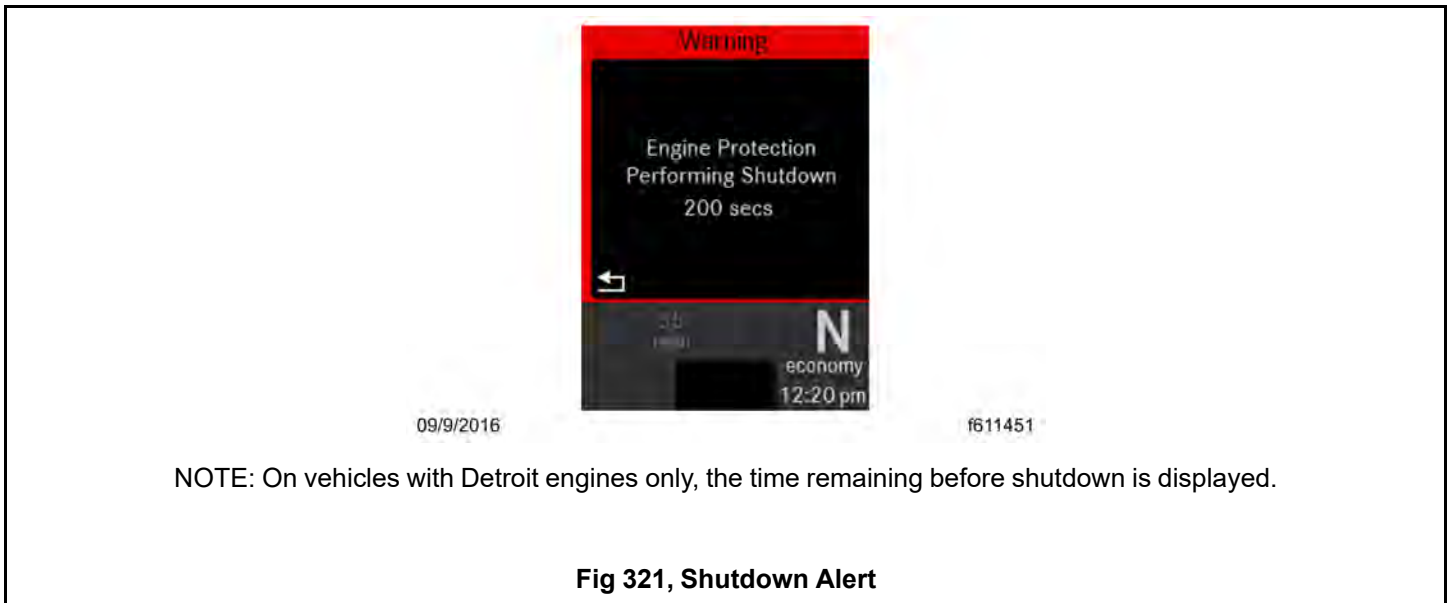
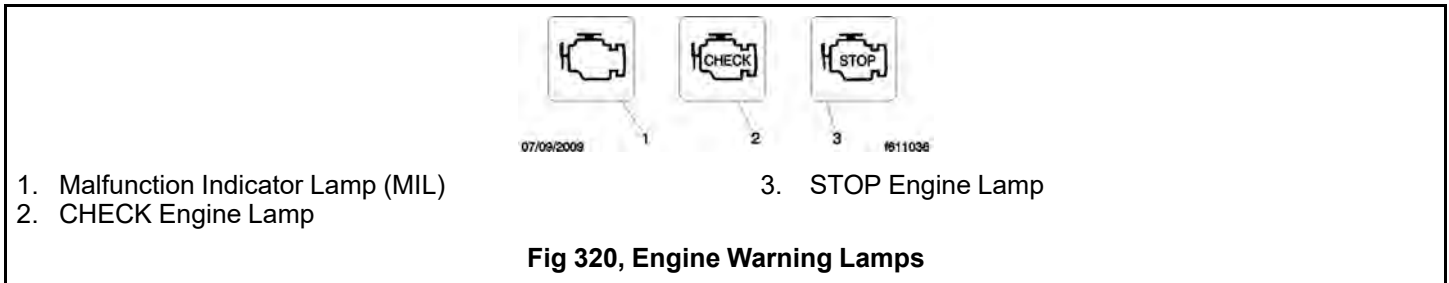

NOTE: On vehicles with Detroit engines only, the time remaining before shutdown is displayed.

Do not operate the vehicle further until the problem causing the shutdown has been corrected.

Some vehicles may have a shutdown override switch, which can be used to momentarily override the shutdown sequence. This switch resets the shutdown timer, restoring power to the level before the derate. The switch must be pressed again after five seconds to obtain a subsequent override. See Fig.322, [Shutdown Override Switch](#) .

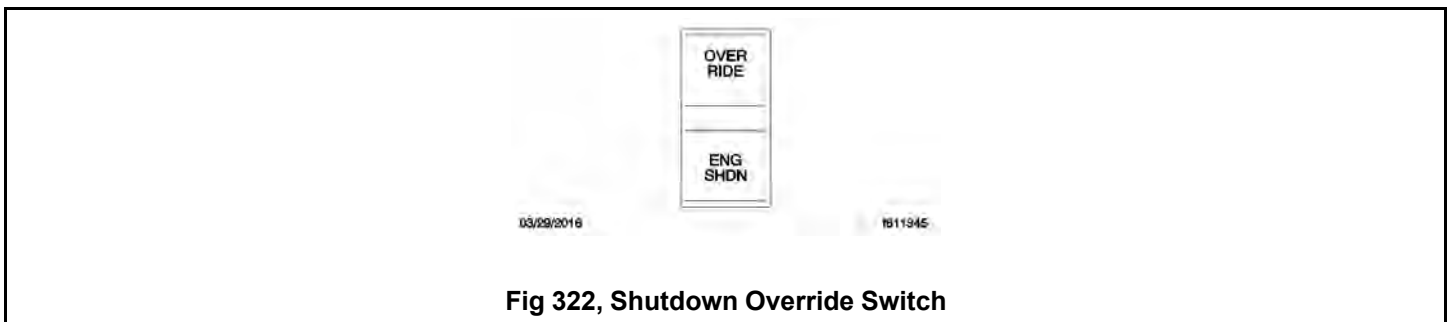

**NOTICE:**

When the derate process begins, immediately get the vehicle serviced in order to prevent severe damage to the engine.

Detroit engines may begin a warning and derate process if water is detected in the fuel, or for high engine coolant temperature. In WARNING and DERATE mode, the CHECK engine, STOP engine, or MIL lamp will illuminate to indicate an engine problem that requires service and the engine controls will begin a derate of engine output. Continuing to run the engine while it is in derate mode could cause severe damage to the engine.

| | |
|---|-----|
| 14.01 Engine Idle Limiting | 366 |
| 14.01.01 Idle Shutdown Timer | 366 |
| 14.02 Optimized Idle® | 366 |
| 14.02.01 General Description, Optimized Idle® | 366 |
| 14.02.02 Activating Optimized Idle | 367 |
| 14.02.03 Reactivating Optimized Idle | 369 |
| 14.02.04 Deactivating Optimized Idle | 370 |
| 14.03 Power Takeoff (PTO) Governor | 370 |

14. Optional Engine Systems

14.01 Engine Idle Limiting

14.01.01 Idle Shutdown Timer

This feature is an optional 1- to 100-minute idle shutdown system with a timer on the driver display screen. Its purpose is to conserve fuel by eliminating excessive idling. Idle shutdown timing and parameters are programmable. See the engine manufacturer's operation manual for specific details for your vehicle.

14.02 Optimized Idle®

14.02.01 General Description, Optimized Idle®

Optimized Idle® is an optional feature on vehicles equipped with Detroit engines. Optimized Idle reduces engine idle time by running the engine only as required when the vehicle is parked.

Optimized Idle automatically shuts down and restarts the engine as needed to:

- keep the engine oil temperature between programmed limits;
- maintain battery voltage;
- keep the cab and sleeper areas at the thermostat setting; and
- in coordination with the Dual HVAC system (if equipped), maintain the battery and assist in HVAC.

The benefits of the system include reduced engine idle time, fuel savings, reduction of exhaust emissions and noise, increased starter and engine life, and a reduced chance of dead batteries.

Optimized Idle operates in the following modes:

- Cold startability mode and battery mode: both modes keep the battery charged and engine oil temperature between programmed limits.
- Interior comfort mode (for sleeper cabs without a Dual HVAC system): keeps the cab and sleeper at a constant preset temperature, in addition to all functions available in cold startability and battery modes. Extended and continuous run modes allow the engine to keep running longer if necessary.
- Interior comfort mode with a Dual HVAC system: keeps the cab and sleeper at a constant preset temperature, in addition to all functions available in cold startability and battery modes.

In cold startability mode, Optimized Idle starts the engine when engine oil temperature drops to a programmable preset lower limit. The engine is shut down when engine oil temperature reaches a programmable upper limit, unless the requirements of other active modes require the engine to keep running.

In battery mode, the engine runs for 2 hours before shutting down. On vehicles without a Dual HVAC system, the engine will run an additional 2 hours in extended mode if necessary, and continuously in continuous mode. When in continuous mode, the driver display will indicate Optimized Idle status as "continuous battery mode." Continuous mode may indicate a problem, such as a bad battery.

Interior comfort mode controls the temperature set point, which is the desired temperature of the cab and sleeper, and the comfort zone, which is the allowed temperature deviation from the set point before the engine starts.

Interior comfort mode with a Dual HVAC system operates with the following parameters regarding the set point and comfort zone:

- If the bunk area temperature reaches more than 10°F (5.5°C) above the set point the comfort zone is exceeded and the Dual HVAC system immediately requests the engine to start for comfort support cooling.
- Bunk area temperatures 5 to 10°F (2.8 to 5.5°C) above the set point for over twenty minutes will cause the Dual HVAC system to request the engine to start for comfort support cooling.
- If the bunk area temperature drops to more than 10°F (5.5°C) below the set point, the comfort zone is exceeded and the Dual HVAC system immediately requests the engine to start for comfort support heating.

- Temperatures 5 to 10°F (2.8 to 5.5°C) below the set point for over twenty minutes will cause the Dual HVAC system to request the engine to start for comfort support for heating.

In extreme ambient conditions, comfort mode may stay on continuously.

NOTE: If the mode settings are changed while in one mode, the system may continue running in another mode.

When Optimized Idle is on, it may turn off these functions to reduce stress on the batteries:

- Cab climate control fan
- Sleeper climate control fan
- Mirror heat
- Fuel/water separator heat
- Seat heat
- Advertising light
- Auxiliary circulation fan (windshield)
- Air dryer

14.02.02 Activating Optimized Idle

The vehicle must be in neutral gear, the hood latched, and the park brake set for Optimized Idle to work. Failure to meet these conditions will result in a checklist pop-up screen showing both the met and unmet conditions. See Fig. 323, [Optimized Idle Activation Conditions Pop-Up](#).

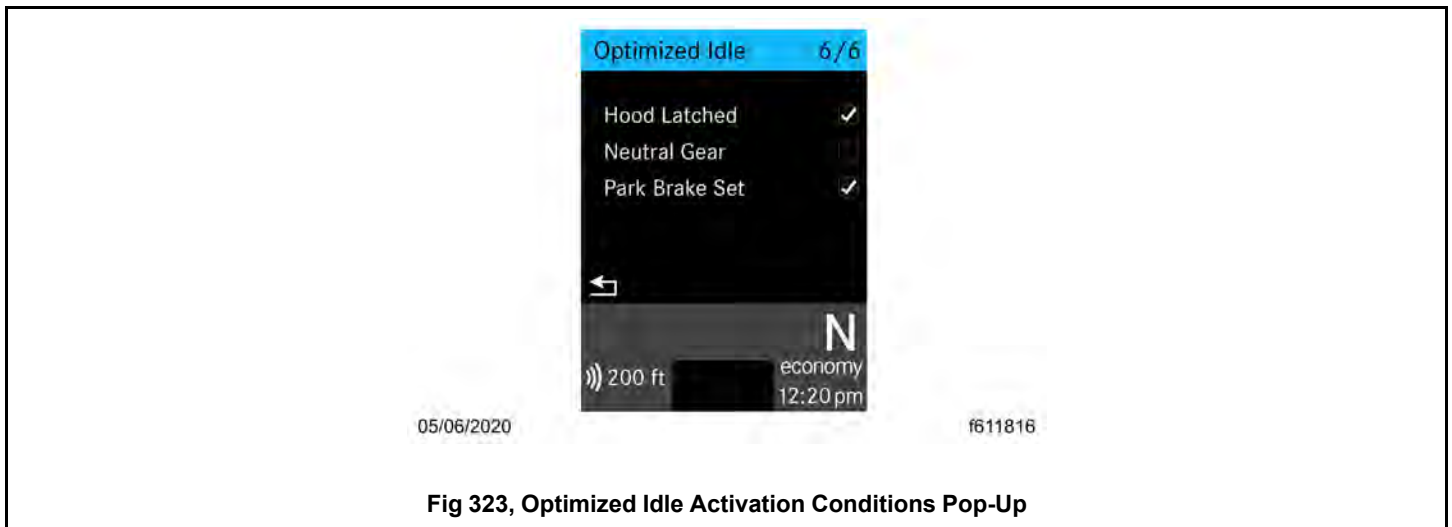

Fig 323, Optimized Idle Activation Conditions Pop-Up

Dismiss the pop-up screen, fix the issue(s), and restart Optimized Idle.

NOTE: Turning the sleeper HVAC fan off will turn off the interior comfort mode until the fan is turned back on.

1. Set the parking brake.
2. If open, close and secure the hood.
3. Allow the engine to idle if it is running. If the engine is not running, turn the key to the ON position.
4. Put the transmission in neutral.
5. Navigate to the Optimized Idle screen on the driver display. See Fig.324, [Optimized Idle Start Screen](#).

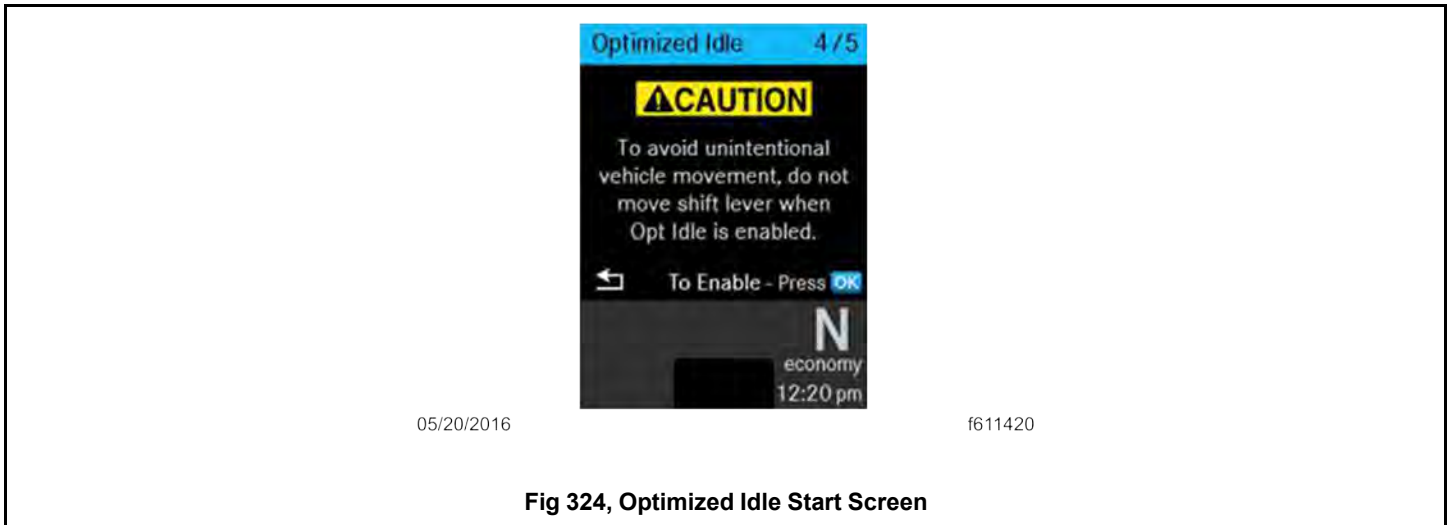

Fig 324, Optimized Idle Start Screen

6. Press OK on the steering wheel switch pod to view the mode option screen. See Fig. 325, [Optimized Idle Mode Selection Screen](#).
7. Select OK to enable Optimized Idle, and, if desired, turn on the interior comfort mode (sleeper cabs only). The current Optimized Idle state is displayed. See Fig. 326, [Optimized Idle State Screen](#).

When Optimized Idle is active, the Optimized Idle telltale illuminates at the bottom of the driver display. See Fig. 327, [Optimized Idle Telltale](#).

If Optimized Idle fails to start, see the driver display for information.

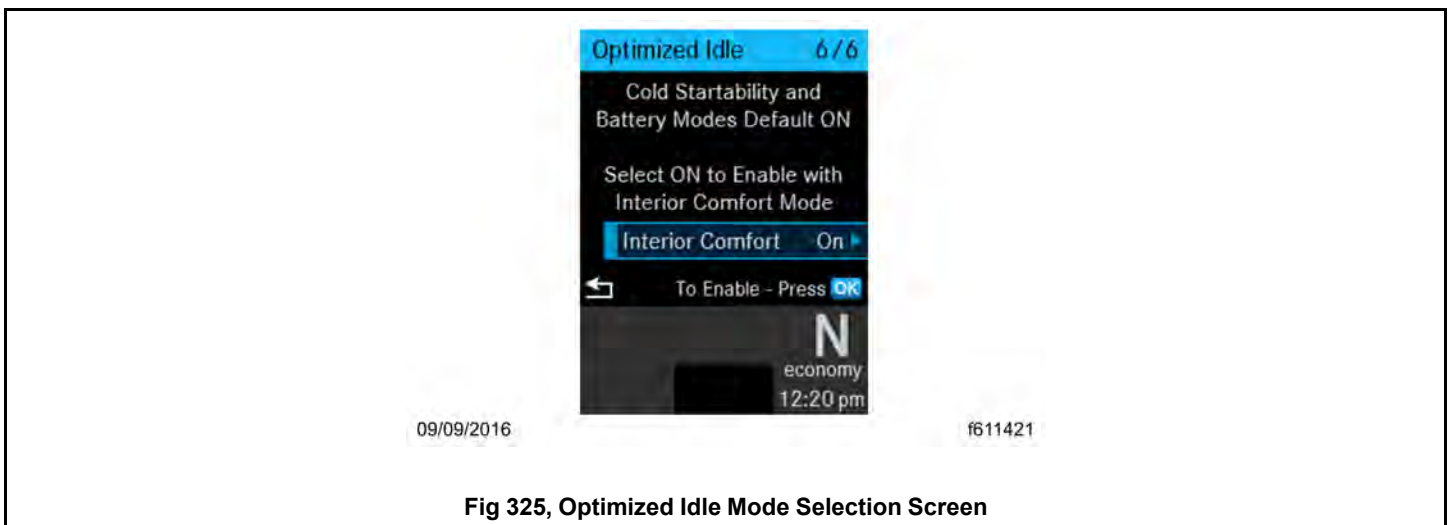

Fig 325, Optimized Idle Mode Selection Screen

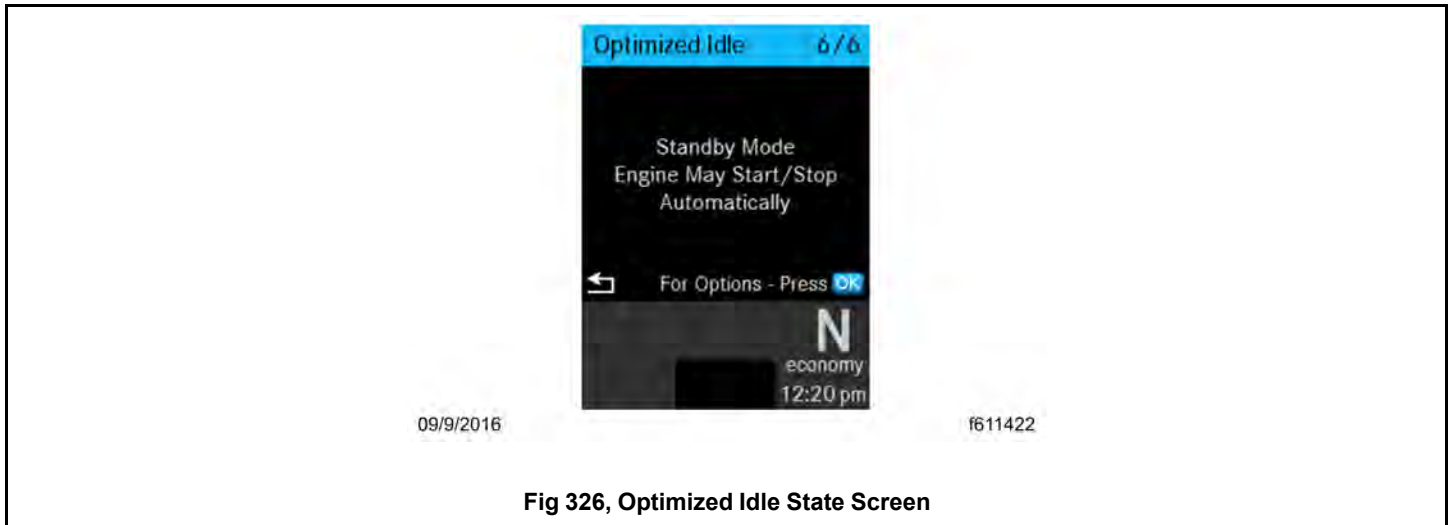

Fig 326, Optimized Idle State Screen

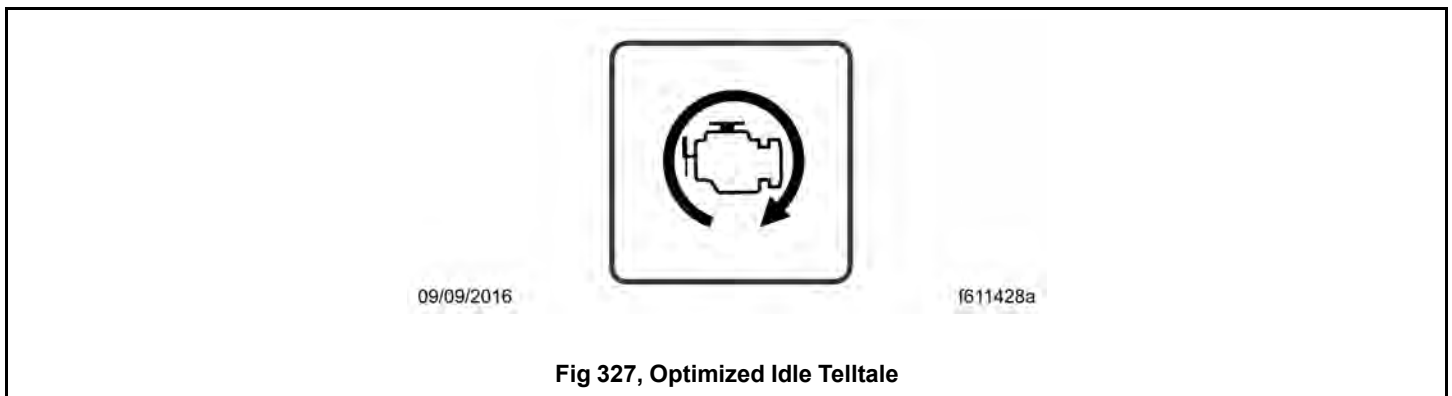

Fig 327, Optimized Idle Telltale

8. If the interior comfort mode is activated (sleeper cabs only), set the desired temperature and fan speed on the sleeper HVAC controls.

The allowable temperature range for Optimized Idle operation is 65 to 80°F (18 to 27°C).

Optimized Idle will operate the engine, starting and turning it off as needed to maintain battery charge, engine oil temperature, and cab/sleeper temperature.

14.02.03 Reactivating Optimized Idle

If the hood is opened or the vehicle is put into gear while Optimized Idle is running, the system will enter a safety loop and a pop-up will appear. See Fig.328, [Safety Loop Pop-Up](#). Restoring operating conditions (e.g. closing the hood or setting the transmission in neutral) and performing a key cycle will allow Optimized Idle to be reactivated.

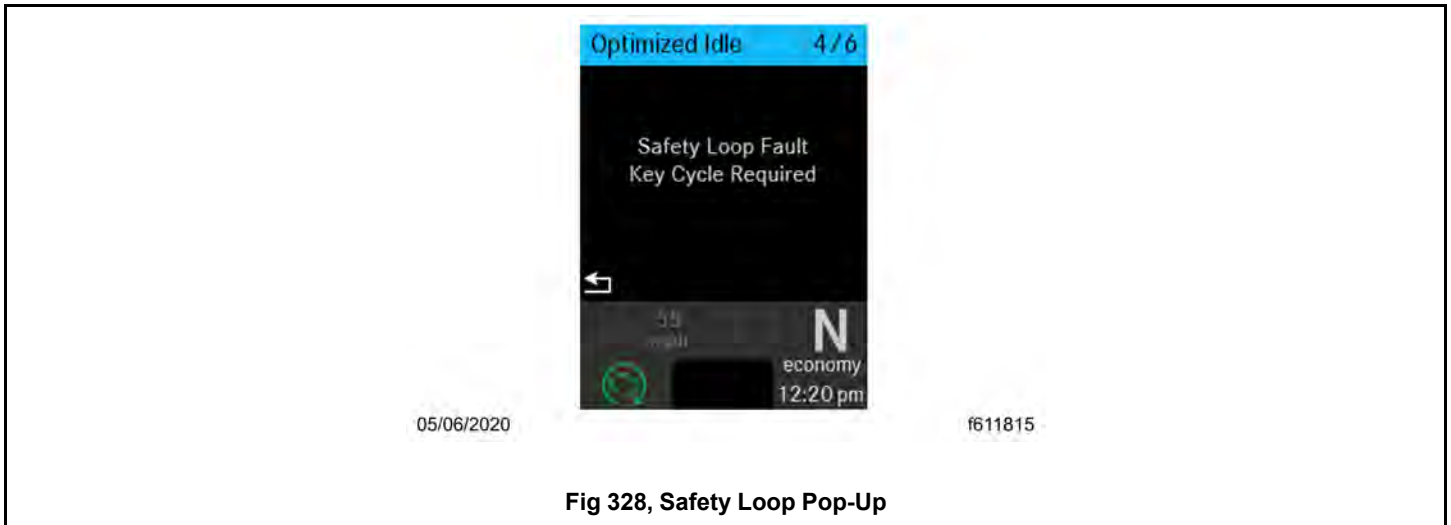

Fig 328, Safety Loop Pop-Up

14.02.04 Deactivating Optimized Idle

Optimized Idle can be shut down by:

- using the Optimized Idle menu screens on the driver display;
- turning off the ignition;
- using the drive-away feature, as follows:
 - If the engine is running: Release the parking brakes, put the transmission in gear (automated/automatic transmissions), or depress the clutch (manual transmissions).
If the engine is not running: Start the engine. Release the parking brakes, put the transmission in gear (automated/automatic transmissions), or depress the clutch (manual transmissions).
 - Let the engine return to base idle. The telltale will turn off. Optimized Idle is now disabled.

14.03 Power Takeoff (PTO) Governor



WARNING:

To avoid injury, do not install a PTO that is not Detroit Diesel approved onto a Detroit Transmission. Use of a non-Detroit Diesel approved PTO with a Detroit Transmission could result in unintended operation which could lead to severe personal injury.

Engine power takeoffs (PTO) tap into engine power to run auxiliary devices, such as hydraulic pumps that power additional equipment. The following are general guidelines for operating a PTO.

1. Set the parking brake and put the transmission in neutral.
2. Press the dash PTO switch. Release the switch when the light begins to blink.
When the light illuminates steadily, the PTO is engaged and ready to operate. In stationary mode, the vehicle must remain in neutral with the parking brake set.
3. To activate mobile mode, shift from neutral to reverse, 1st, or 2nd gear. The clutch will open and the PTO will disengage for a moment.
4. Touch the accelerator pedal to close the clutch and engage the PTO in mobile mode. The PTO may be operated with the transmission in neutral or reverse, and 1st and 2nd gears only.

NOTE: Do not attempt to change gears while the vehicle is moving. The transmission will ignore the request.

5. To deactivate mobile mode, bring the vehicle to a stop. The clutch will open and shut down power to the PTO.
6. To resume stationary mode, shift to neutral. The PTO will engage.
7. To deactivate PTO, press the PTO switch again. When the light in the switch goes out, power to the PTO is shut off.

| | |
|--|-----|
| 15.01 Greenhouse Gas Emissions and Fuel Consumption Standards..... | 374 |
| 15.02 EPA-Regulated Emissions Aftertreatment Systems..... | 374 |
| 15.02.01 Euro V Emission Compliant Engines for Export | 374 |
| 15.02.02 EPA10 and Newer Engines | 375 |
| 15.02.03 Regeneration..... | 376 |
| 15.02.04 ATS Warning Lamps and Messages | 379 |
| 15.02.05 Maintenance, Aftertreatment Systems | 383 |
| 15.03 Diesel Exhaust Fluid and Tank..... | 384 |
| 15.03.01 Diesel Exhaust Fluid..... | 384 |
| 15.03.02 DEF Tank | 384 |
| 15.03.03 Fuel/DEF Gauge..... | 384 |
| 15.03.04 DEF Warnings and Engine Limits | 385 |

15. Emissions and Fuel Efficiency

15.01 Greenhouse Gas Emissions and Fuel Consumption Standards

Model year 2007 and later vehicles and/or engines domiciled in the U.S. or Canada are designed to meet Emission and Fuel Efficiency Standards of the U.S. (Federal) Environmental Protection Agency (EPA), the National Highway Traffic Safety Administration (NHTSA), Emission Regulations under the Canada Motor Vehicle Safety Act in Canada, and the California Air Resources Board (CARB) effective as per the applicable emission model year. To determine an engine's or vehicle's emission model year, refer to the respective EPA/CARB certification label.

15.02 EPA-Regulated Emissions Aftertreatment Systems

15.02.01 Euro V Emission Compliant Engines for Export

**NOTICE:**

Follow these guidelines for engines that comply with EPA07 or newer regulations, or damage may occur to the after-treatment device (ATD) and the warranty may be compromised.

- **Use ultralow-sulfur diesel with 15 ppm sulfur content or less.**
- **Do not use fuel blended with used engine lube oil or kerosene.**
- **Use only approved engine lube oil. For lists of engine oils approved for Detroit Diesel engines, refer to the Engine Operator Manual, accessible on Lubricants, Fuels & Coolants on the DTNA Portal. For third party engines, please refer to the engine manual.**

IMPORTANT: Using non-specification fuels or oils can lead to shortened diesel particulate filter (DPF) cleaning or replacement intervals.

IMPORTANT: See the engine manufacturer's operation manual for complete details and operation of the ATS.

IMPORTANT: Depending on local jurisdictional guidelines, vehicles that are domiciled outside of the U.S. and Canada may not have emissions aftertreatment systems (ATS) that are compliant with EPA regulations. Vehicles sold with Euro V engines for export are required to use diesel with a maximum sulfur content as follows:

- Cummins Engines 50 ppm (tolerant to 500 ppm)
- Detroit Engines 50 ppm

See Fig. 329, [Euro V Engine Label \(Detroit engine label shown\)](#) for an example of the label.



06/11/2018

f080203

NOTE: (Use diesel with a maximum sulfur content of 50 ppm)

Fig 329, Euro V Engine Label (Detroit engine label shown)

15.02.02 EPA10 and Newer Engines

**NOTICE:**

Follow these guidelines for engines that comply with EPA07 or newer regulations, or damage may occur to the after-treatment device (ATD) and the warranty may be compromised.

- **Use ultralow-sulfur diesel with 15 ppm sulfur content or less.**
- **Do not use fuel blended with used engine lube oil or kerosene.**
- **Use only approved engine lube oil. For lists of engine oils approved for Detroit Diesel engines, refer to the Engine Operator Manual, accessible on Lubricants, Fuels & Coolants on the DTNA Portal. For third party engines, please refer to the engine manual.**

IMPORTANT: Using non-specification fuels or oils can lead to shortened diesel particulate filter (DPF) cleaning or replacement intervals.

IMPORTANT: See the engine manufacturer's operation manual for complete details and operation of the ATS.

The EPA mandates that all engines built after December 31, 2009 must reduce the level of emissions exhausted by the engine to the following levels:

- Nitrogen Oxides (NOx) – 0.2 g/bhp-hr
- Particulate Matter (PM) – .01 g/bhp-hr

To meet EPA guidelines, engines that are compliant with EPA10 and newer regulations use an ATS where the exhaust first passes over the diesel oxidation catalyst (DOC), then passes through the diesel particulate filter (DPF), which traps soot particles. The soot is burned to ash during a process called regeneration (regen). A Selective Catalytic Reduction (SCR) device is used to reduce NOx downstream of the engine. After exhaust gases leave the DPF, a controlled quantity of diesel exhaust fluid (DEF) is injected into the exhaust stream. In the presence of heat, DEF is converted to ammonia gas, which reacts with NOx in the selective catalyst chamber to yield nitrogen and water vapor, which exit through the tailpipe.

15.02.03 Regeneration

General Description, Regeneration

**NOTICE:**

Follow these guidelines for engines that comply with EPA07 or newer regulations, or damage may occur to the after-treatment device (ATD) and the warranty may be compromised.

- **Use ultralow-sulfur diesel with 15 ppm sulfur content or less.**
- **Do not use fuel blended with used engine lube oil or kerosene.**
- **Use only approved engine lube oil. For lists of engine oils approved for Detroit Diesel engines, refer to the Engine Operator Manual, accessible on Lubricants, Fuels & Coolants on the DTNA Portal. For third party engines, please refer to the engine manual.**

IMPORTANT: Using non-specification fuels or oils can lead to shortened diesel particulate filter (DPF) cleaning or replacement intervals.

IMPORTANT: See the engine manufacturer's operation manual for complete details and operation of the ATS.

The harder an engine works, the better it disposes of soot. If the exhaust temperature is high enough, a process called **passive regeneration** (regen) occurs as the vehicle is driven normally. However, if the engine isn't running hot enough, the electronic controls may initiate an **active regen**, whereby extra fuel is injected into the exhaust stream to superheat and reduce the soot trapped in the DPF to ash. Active regen happens only when the vehicle is moving above a certain speed, determined by the engine manufacturer. See your engine operation manual for complete details. Both active and passive regen happen automatically, without driver input.

**WARNING:**

Active regeneration can occur automatically anytime the vehicle is moving. The exhaust gas temperature could reach 1500°F (815°C), which is hot enough to cause a fire, heat damage to objects or materials, or personal injury to persons near the exhaust outlet. The exhaust temperature can remain high even after the vehicle has stopped. When stopping the vehicle shortly after an automatic regen, ensure the exhaust outlets are directed away from structures, vegetation, flammable materials, and anything else that may be harmed by exposure to high heat.

See **Regen Switches**, below, for instructions on preventing automatic regen if necessary.

When operating conditions do not allow for ATD filter cleaning by active or passive regen, the vehicle may require a driver-activated **parked regen**. When this occurs, the driver display screen presents a message indicating that a regen is required. See Fig. 330, [Parked Regen Message Screens](#). The driver must either bring the vehicle up to highway speed to increase the load (thus starting an active regen), or park the vehicle and initiate a parked regen. See **Regen Operations**, below, for instructions on initiating a parked regen.

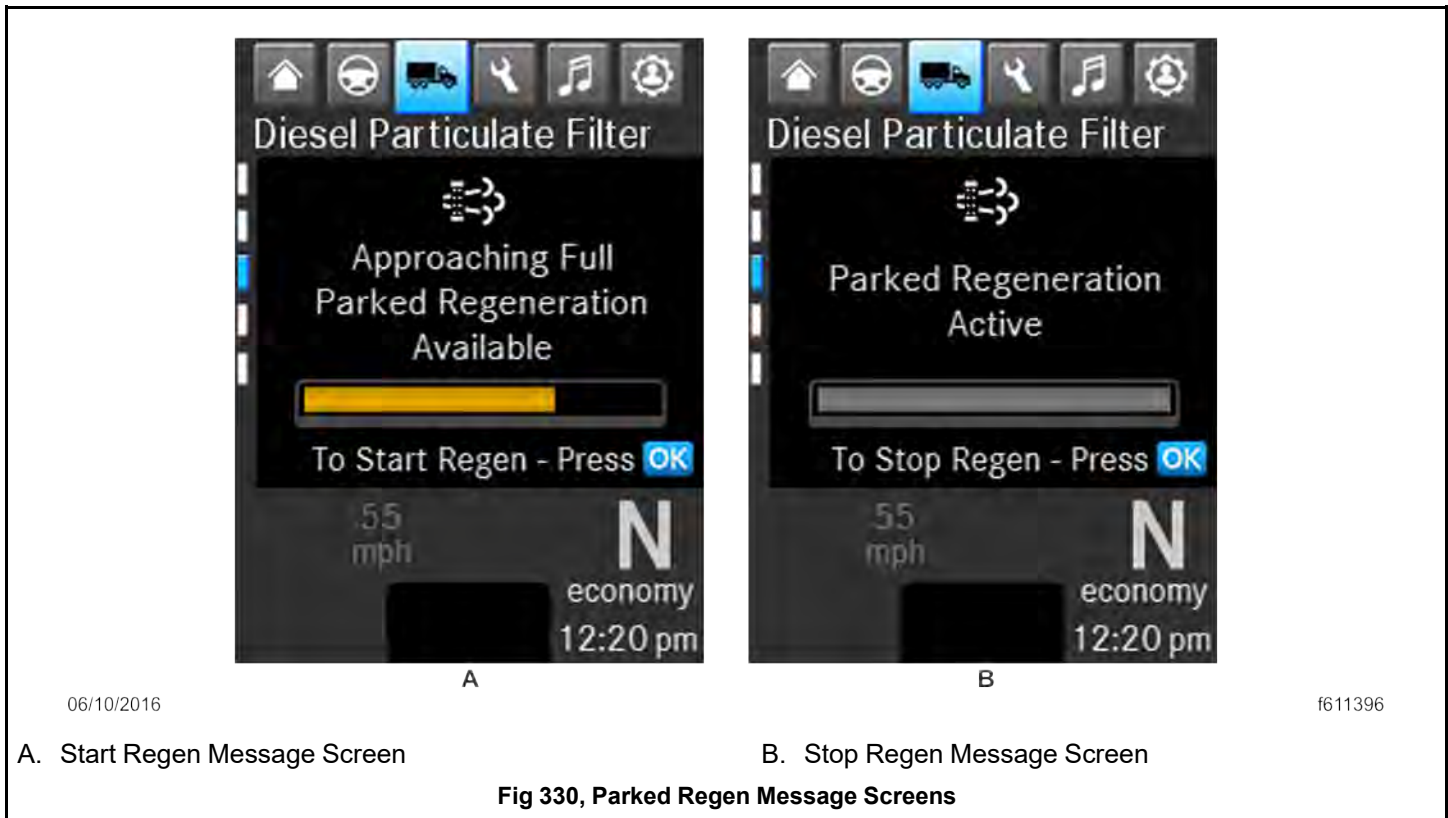

Regen Operations



NOTICE:

Follow these guidelines for engines that comply with EPA07 or newer regulations, or damage may occur to the after-treatment device (ATD) and the warranty may be compromised.

- Use ultralow-sulfur diesel with 15 ppm sulfur content or less.
- Do not use fuel blended with used engine lube oil or kerosene.
- Use only approved engine lube oil. For lists of engine oils approved for Detroit Diesel engines, refer to the Engine Operator Manual, accessible on Lubricants, Fuels & Coolants on the DTNA Portal. For third party engines, please refer to the engine manual.

IMPORTANT: Using non-specification fuels or oils can lead to shortened diesel particulate filter (DPF) cleaning or replacement intervals.

IMPORTANT: See the engine manufacturer's operation manual for complete details and operation of the ATS.

Parked regen is initiated by selecting OK when the driver display screen shows 'Parked Regen Required.' See Fig. 331, [Parked Regen Message Screens](#). If the vehicle is equipped with the optional digital STOP REGEN switch, parked regen can be stopped by selecting OK while the regen is in progress. See Fig. 331, [Parked Regen Message Screens](#).

Some vehicles may be equipped with a regen inhibit switch. See Fig. 332, [Regen Inhibit Switch](#). To stop a regen in progress or prevent the start of a regen, press the lower half of the switch. Regen is then delayed until the switch is no longer active.

NOTE: Parked regen can be initiated only when the DPF lamp is illuminated.

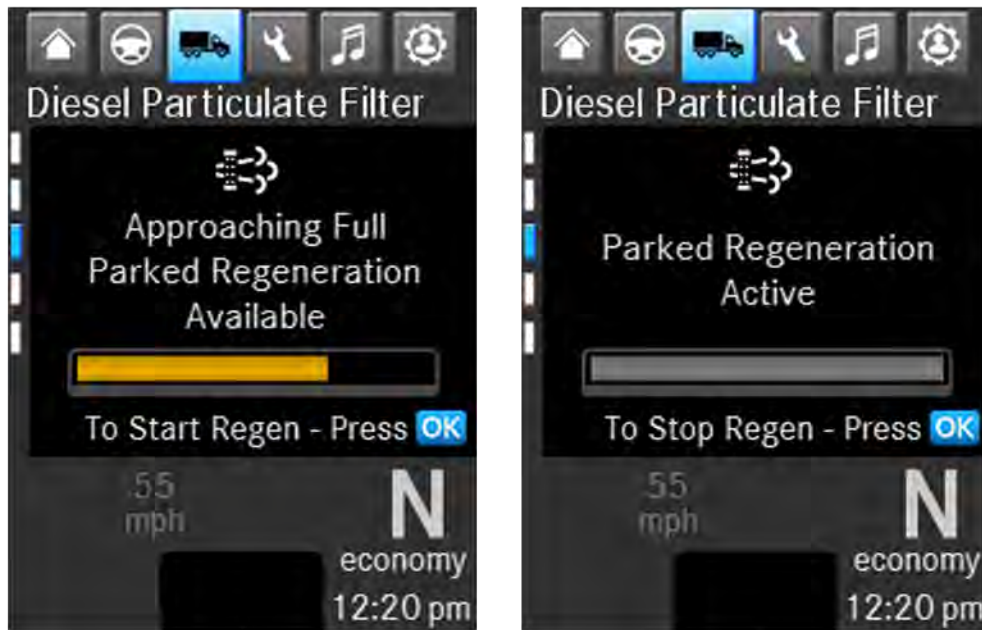

06/10/2016

f611396

A. Start Regen Message Screen

B. Stop Regen Message Screen

Fig 331, Parked Regen Message Screens

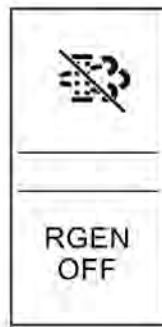

07/06/2020

f611395

Fig 332, Regen Inhibit Switch



WARNING:

During parked regen, exhaust temperatures are very high and could cause a fire, heat damage to objects or materials, or personal injury to persons near the exhaust outlet.

Before initiating a parked regeneration, make certain the exhaust outlets are directed away from structures, vegetation, flammable materials, and anything else that may be harmed by prolonged exposure to high heat.

To initiate a parked regen, perform the following steps:

1. Park the vehicle away from all flammable materials, put the transmission in neutral, and set the parking brake.
2. Start and warm the engine until the coolant temperature is at least 150°F (66°C).

IMPORTANT: The driver is responsible for ensuring, during the entire regen cycle, that anything that could be harmed by exposure to high heat does not come in contact with the exhaust gases flowing from the outlets.

3. Select OK when the DPF screen is displayed on the driver display screen. See Fig. 331, [Parked Regen Message Screens](#). Select OK again to confirm regen. As the regen process is initiated, engine rpm increases and the HEST lamp illuminates to indicate extremely high exhaust temperatures.
4. The regen cycle will finish after 20 to 60 minutes, at which time engine idle speed drops to normal and the vehicle can be driven normally. The HEST lamp is extinguished when vehicle speed exceeds 5 mph (8 km/h) or the system has cooled to normal operating temperature.
5. To stop a parked regen at any time during the process:
 - depress the clutch pedal, brake pedal, or accelerator pedal;
 - select OK on the parked regen screen while the regen is active, then select OK again to confirm;
 - press and hold the regen inhibit switch until idle returns to normal;
 - shut down the engine.

15.02.04 ATS Warning Lamps and Messages



NOTICE:

Follow these guidelines for engines that comply with EPA07 or newer regulations, or damage may occur to the after-treatment device (ATD) and the warranty may be compromised.

- **Use ultralow-sulfur diesel with 15 ppm sulfur content or less.**
- **Do not use fuel blended with used engine lube oil or kerosene.**
- **Use only approved engine lube oil. For lists of engine oils approved for Detroit Diesel engines, refer to the Engine Operator Manual, accessible on Lubricants, Fuels & Coolants on the DTNA Portal. For third party engines, please refer to the engine manual.**

IMPORTANT: Using non-specification fuels or oils can lead to shortened diesel particulate filter (DPF) cleaning or replacement intervals.

IMPORTANT: See the engine manufacturer's operation manual for complete details and operation of the ATS.

There are three warning lamps that alert the driver of high exhaust temperature, the need to perform a parked regen or service the DPF, or of an engine fault that affects emissions. A decal attached to the driver's sun visor explains the ATS warning lamps.

Malfunction Indicator Lamp (MIL)

A steadily illuminated yellow malfunction indicator lamp (MIL) indicates an engine fault that affects emissions. See Fig. 333, [Malfunction Indicator Lamp \(MIL\)](#).

DPF Status Lamp and Messages

When soot accumulates in the DPF, the driver display screen presents a DPF status bar. As the soot level in the DPF reaches 60%, the DPF status lamp illuminates. See Fig. 334, [DPF Status Lamp](#). Perform a parked regen or bring the vehicle up to highway speed to increase the load (thus starting an active regen). After the soot level in the DPF reaches 80%, a parked regen is necessary.

For an explanation of DPF zones, message screens, warning lamps, and available regen modes, see Table 35, [DPF Zones, Detroit Engines](#) (Detroit engines) or Table 36, [DPF Zones, Cummins Engines](#) (Cummins engines).

If the DPF status lamp blinks and the driver display screen shows a red status bar (90% full), initiate a parked regen immediately in order to prevent an engine derate.

If the DPF status lamp blinks, and the driver display screen shows a DPF status bar that is fully red (100% full), begin a parked regen in order to prevent an engine shutdown. Park the vehicle and perform a parked regen.



















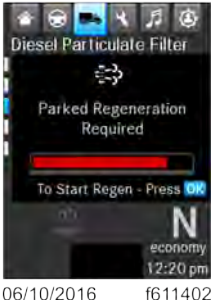

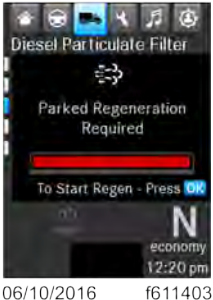
| DPF Zone | DPF Status Bar | Warning Lamps | Regen Mode Available |
|----------|---|---|---|
| 0 |  <p>06/10/2016 f611398 0–10% Green</p> | — | <ul style="list-style-type: none"> passive |
| 1 |  <p>06/10/2016 f611399 10–60% Green</p> | — | <ul style="list-style-type: none"> over-the-road |
| 2 |  <p>06/10/2016 f611400 60–70% Yellow</p> |  <p>DPF solid yellow</p>  <p>HEST solid yellow ¹</p> | <ul style="list-style-type: none"> over-the-road parked |

Table 35, DPF Zones, Detroit Engines

| DPF Zone | DPF Status Bar | Warning Lamps | Regen Mode Available |
|----------|--|---|---|
| 3 |  <p>70–80% Yellow</p> |  <p>DPF flashing yellow</p>  <p>HEST solid yellow</p> | <ul style="list-style-type: none"> • over-the-road • parked |
| 4 |  <p>80–90% Red</p> |  <p>DPF flashing yellow</p>  <p>HEST solid yellow</p> | <ul style="list-style-type: none"> • parked |
| 5 |  <p>90–100% Red</p> |  <p>DPF flashing yellow</p>  <p>HEST solid yellow</p> | <ul style="list-style-type: none"> • parked |

1. Illuminates if exhaust temperature is above a preset limit.

Table 34, DPF Zones, Detroit Engines

| DPF Zone | DPF Status Bar | Warning Lamps | Regen Mode Available |
|----------|--|--|---|
| 1 |  <p>0–60% Green</p> | — | <ul style="list-style-type: none"> • over-the-road |
| 3 |  <p>60–80% Yellow</p> |  <p>DPF flashing yellow</p>  <p>HEST solid yellow ¹</p> | <ul style="list-style-type: none"> • over-the-road • parked |
| 5 |  <p>80–100% Red</p> |  <p>DPF flashing yellow</p>  <p>HEST solid yellow</p> | <ul style="list-style-type: none"> • parked |

1. Illuminates if exhaust temperature is above a preset limit.

Table 35, DPF Zones, Cummins Engines

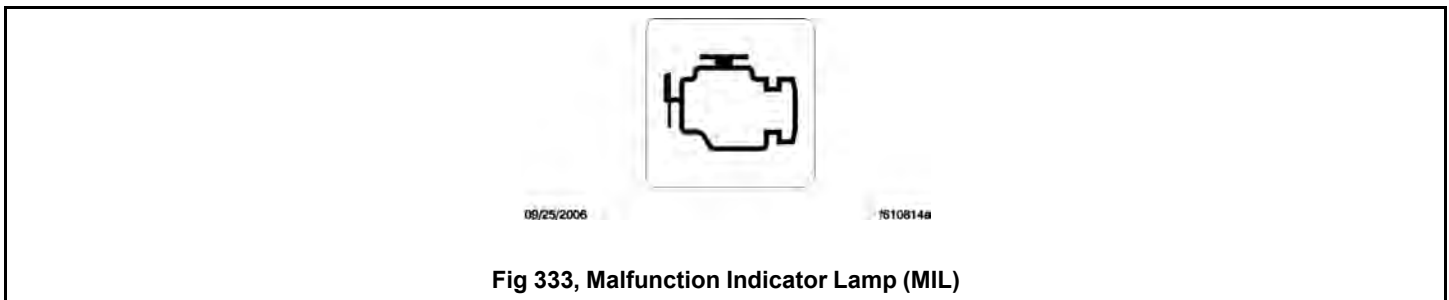
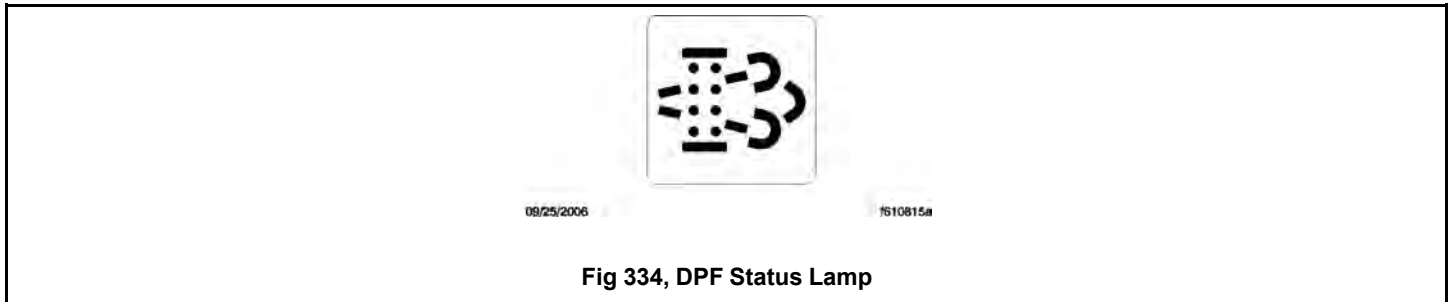

Fig 333, Malfunction Indicator Lamp (MIL)



High Exhaust System Temperature (HEST) Lamp

Slow (10-second) flashing of the high exhaust system temperature (HEST) lamp indicates that a parked regen is in progress, and the engine's high idle speed is being controlled by the engine software, not the vehicle driver.

Steady illumination of the HEST lamp alerts the driver of high exhaust temperature during the regen process if the vehicle speed is below 5 mph (8 km/h), or during a parked regen. See Fig. 335, [HEST Lamp](#).

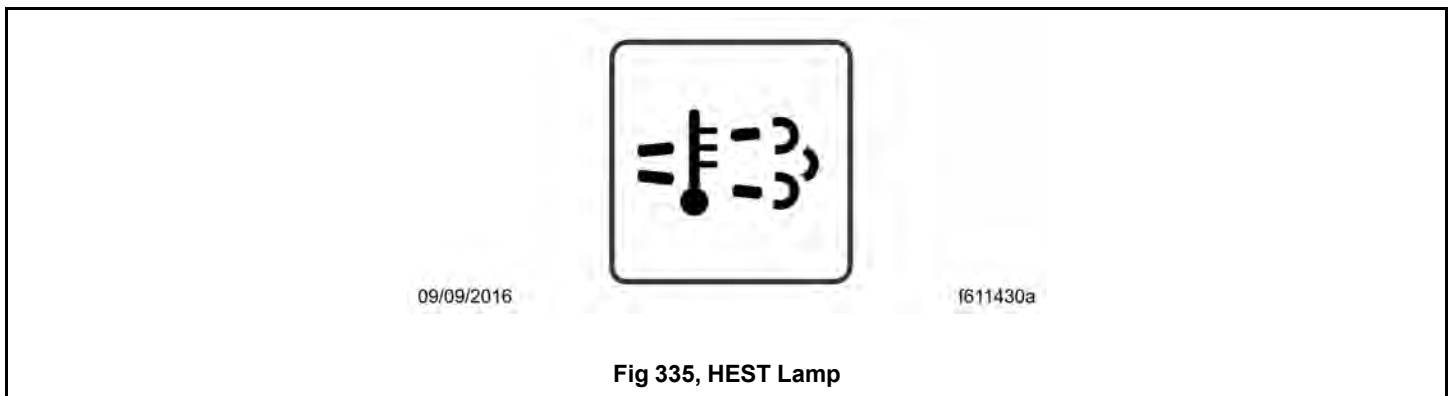

15.02.05 Maintenance, Aftertreatment Systems



NOTICE:

Follow these guidelines for engines that comply with EPA07 or newer regulations, or damage may occur to the after-treatment device (ATD) and the warranty may be compromised.

- **Use ultralow-sulfur diesel with 15 ppm sulfur content or less.**
- **Do not use fuel blended with used engine lube oil or kerosene.**
- **Use only approved engine lube oil. For lists of engine oils approved for Detroit Diesel engines, refer to the Engine Operator Manual, accessible on Lubricants, Fuels & Coolants on the DTNA Portal. For third party engines, please refer to the engine manual.**

IMPORTANT: Using non-specification fuels or oils can lead to shortened diesel particulate filter (DPF) cleaning or replacement intervals.

IMPORTANT: See the engine manufacturer's operation manual for complete details and operation of the ATS.

Authorized service facilities must perform any DPF service. For warranty purposes, maintain a record that includes:

- date of cleaning or replacement;

- vehicle mileage;
- particulate filter part number and serial number.

15.03 Diesel Exhaust Fluid and Tank

15.03.01 Diesel Exhaust Fluid

Diesel exhaust fluid (DEF) is used in the ATS to lower NOx in the exhaust stream. DEF is colorless and close to odorless (it may have a slightly pungent odor similar to ammonia). It is nontoxic, nonflammable, and biodegradable. It is mildly corrosive to aluminum, but does not affect the strength or structure of the aluminum.

White crystals may be noticeable around components that come into contact with DEF. The crystals are easily removed with water.

DEF consumption varies depending on ambient conditions and vehicle application.

Freezing Conditions

DEF freezes to slush at around 12°F (-11°C). It is not damaged or destroyed if frozen, and is fully usable when thawed. The DEF in the tank is allowed to freeze while a vehicle is non-operational. At start-up, normal operation of the vehicle is not inhibited if the DEF is frozen; an immersion heater with engine coolant flowing through it warms the DEF once the engine is running, allowing the SCR system to operate.

15.03.02 DEF Tank

Engines that are compliant with EPA10 and newer regulations are equipped with a DEF tank located on the driver's side of the vehicle behind the battery box or forward of the fuel tank. The DEF tank has a 19 mm filler neck inlet that prevents the hose from a diesel outlet from being inserted, and has a blue cap for easy identification.

15.03.03 Fuel/DEF Gauge

The diesel fuel and DEF levels are measured in a dual-purpose gauge. Below the gauge, a low fuel warning lamp illuminates amber when the fuel level drops below 1/8th of the capacity. See Fig. 336, [Fuel/DEF Gauge](#).

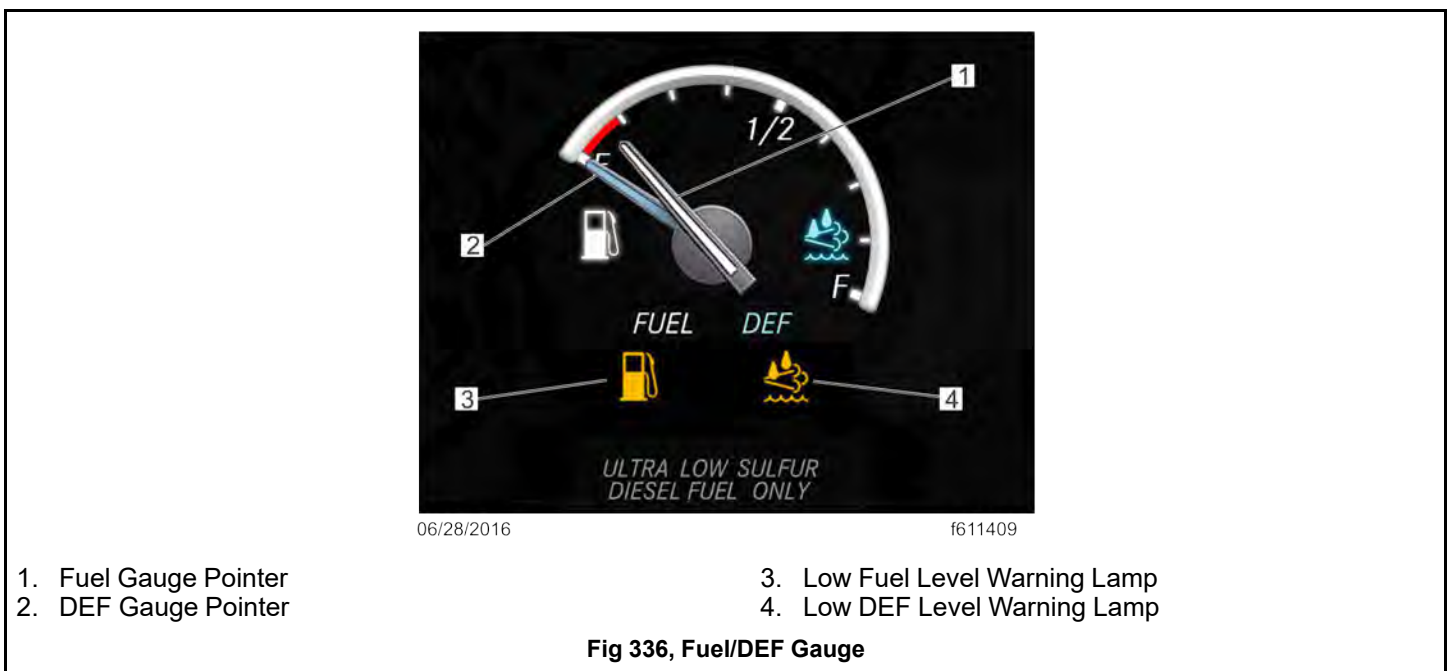

A DEF warning lamp illuminates amber when the DEF tank is near empty.

15.03.04 DEF Warnings and Engine Limits

IMPORTANT: Ignoring the DEF low level warnings results in limited engine power, with the application of a 5 mph (8 km/h) speed limit.

DEF Level Low—Initial Warning

When the DEF level is low, the DEF warning lamp illuminates solid amber, and the driver display screen presents an alert. See Fig. 337, [DEF Level Messages](#). Refill the DEF tank in order to cancel the warning sequence.

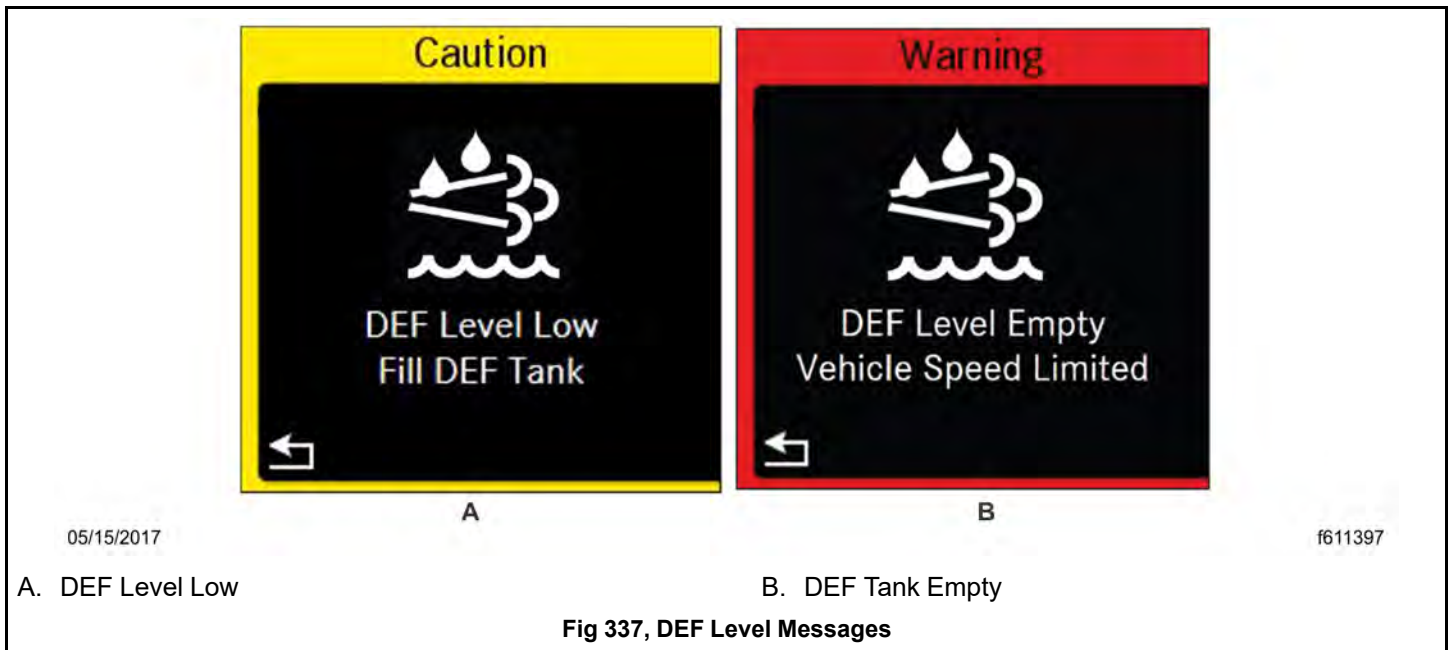

DEF Empty

When the DEF level reads empty, the following lamps and messages notify the driver.

- The DEF warning lamp flashes amber.
- The MIL lamp illuminates.
- The driver display screen presents the warning, 'DEF Tank Empty.' See Fig. 337, [DEF Level Messages](#).

Power is limited with progressively harsher engine power limits applied.

DEF Tank Empty and Ignored

If the empty warning is ignored and the DEF tank is not refilled, the red STOP engine lamp illuminates in addition to the MIL lamp and CHECK engine lamp (on vehicles with a Cummins ISB or ISC/L engine).

If the DEF is not refilled, a 5 mph (8 km/h) speed limit is applied after the next engine shutdown, while parked and idling, or if a fuel refill is detected.

DEF Contamination or SCR Tampering

**NOTICE:**

Once contaminated DEF or tampering has been detected, the vehicle must be taken to an authorized service facility to check the SCR system for damage and to deactivate the warning lights and engine limits.

If contaminated DEF or tampering with the ATS is detected, the DEF warning light flashes and the MIL lamp illuminates to warn the driver. The CHECK engine lamp also illuminates on vehicles with a Cummins ISB or ISC/L engine.

- Detroit engines: Engine power is limited with progressively harsher limits applied. If the fault is not corrected, the STOP engine light illuminates and a 5 mph (8 km/h) speed limit is applied after the next engine shutdown, while parked and idling, or if a fuel refill is detected.
- Cummins engines: Engine power is limited with progressively harsher limits applied. If the fault is not corrected, the STOP engine light illuminates and a 5 mph (8 km/h) speed limit is applied after the next engine shutdown, or while parked and idling.

| | |
|--|-----|
| 16.01 Air Brake System..... | 388 |
| 16.01.01 Brake System General Information | 388 |
| 16.01.02 Operation of the Brake System..... | 390 |
| 16.01.03 Automatic Slack Adjusters | 392 |
| 16.02 Meritor WABCO® Antilock Braking System | 392 |
| 16.02.01 General Description | 392 |
| 16.02.02 Trailer ABS Compatibility | 394 |
| 16.02.03 Automatic Traction Control..... | 395 |
| 16.02.04 ECAS Automatic Load Transfer (ECAS only)..... | 397 |
| 16.03 Engine Brake | 398 |
| 16.03.01 General Description | 398 |
| 16.03.02 Operation of the Engine Brake | 400 |

16. Brake Systems

16.01 Air Brake System

16.01.01 Brake System General Information

A dual air brake system consists of two independent air systems that use a single set of brake controls. Each system has its own reservoirs, plumbing, and brake chambers. The primary system operates the service brakes on the rear axle; the secondary system operates the service brakes on the front axle. Service brake signals from both systems are sent to the trailer.



WARNING:

Do not operate the vehicle with the front brakes backed off or disconnected. Backing off or disconnecting the front brakes will not improve vehicle handling and may lead to loss of vehicle control, resulting in property damage or personal injury.

If air pressure drops below approximately 70 psi (483 kPa) in either system, a warning telltale illuminates and the driver display shows a warning pop-up. See the first line of Table.37, [Brake System Warnings, Indicators, and Messages](#) for examples of the telltale and ICU warning.

NOTE: An audible alert also sounds if the park brake is not set.

If the low air pressure warning is activated, check the air pressure gauges to determine which system has low air pressure. Although the vehicle's speed can be reduced using the foot brake control pedal, either the front or rear service brakes will not be operating at full capacity, causing a longer stopping distance. Bring the vehicle to a safe stop and have the air system repaired before continuing.

NOTE: The warning buzzer for low air pressure is suppressed on some vehicles when the vehicle is stationary.

| Brake System Warnings, Indicators, and Messages | | | | |
|---|-------|------------------------------------|--|------------------------|
| Telltale | Color | Description | | Driver Display |
| | Red | Low Air Pressure (EPA10 and Newer) | Indicates air pressure in the primary or secondary reservoir has dropped below approximately 70 psi (483 kPa). A buzzer will also sound if the park brake is released or if the vehicle is moving—depending on vehicle options. | 06/30/2016 f611429 |
| | Red | Parking Brake (EPA10 and Newer) | Indicates the parking brake is engaged. | N/A |
| | Amber | Vehicle ABS | Momentary illumination indicates the vehicle ABS is engaged. | N/A |

Table 37, Brake System Warnings, Indicators, and Messages







| Brake System Warnings, Indicators, and Messages | | | | |
|---|-------|------------------|---|---|
| Telltale | Color | Description | | Driver Display |
| | | | Solid illumination indicates a problem with the vehicle ABS. Repair the ABS immediately to ensure full braking capability. | |
|  | Amber | Trailer ABS | Momentary illumination indicates the trailer ABS is engaged. Solid illumination indicates a problem with the trailer ABS. Repair the ABS immediately to ensure full braking capability. | N/A |
|  | Amber | Stability Event | Flashing indicates a stability event has been detected, and the ESC system is active. Solid illumination indicates a problem with the stability system. Repair the ESC system immediately to ensure full stability capability. For more information on the ESC system, see 8.01.01 General Description, Standard Adaptive Cruise Control . | N/A |
|  | Amber | Wheel Spin Event | Flashing indicates a wheel spin event has been detected, and the ATC system is active. | N/A |
|  | | ATC Deactivated | Indicates the ATC SPIN button has been pressed to allow wheel slip. |  10/24/2017 f611457c |
|  | Green | Engine Brake | Indicates the engine brake is enabled. | N/A |

Table 36, Brake System Warnings, Indicators, and Messages

IMPORTANT: In the event of a total loss of service brakes with full system air pressure, use the parking brake control valve (yellow knob) to bring the vehicle to a complete stop in the safest location possible.

Before a vehicle with insufficient system air pressure can be moved, the spring parking brakes must be released by applying an external air source at the gladhands, or by manually caging the parking brake springs.

**WARNING:**

Do not release the spring parking brakes and then drive the vehicle. There would be no means of stopping the vehicle, which could result in serious personal injury or vehicle damage. Before releasing the spring parking brakes, make the connection to a towing vehicle or chock the tires.

After correcting the brake system problem, uncage the spring parking brakes before resuming normal vehicle operation.

Loss of air pressure in the primary air system causes the rear service brakes to become inoperative. The secondary air system will continue to operate the front brakes and, if equipped, the trailer brakes.

Loss of air pressure in the secondary air system causes the front axle brakes to become inoperative. The primary air system will continue to operate the rear service brakes and, if equipped, the trailer brakes.

16.01.02 Operation of the Brake System

Before driving your vehicle, allow time for the air compressor to build up a minimum of 100 psi (690 kPa) pressure in both the primary and secondary systems. Monitor the air pressure system by observing the air pressure gauges and the low-air-pressure warning light and buzzer. The warning telltale or buzzer shut off when air pressure in both systems reaches approximately 70 psi (483 kPa).

NOTE: The buzzer is suppressed on some vehicles when the vehicle is stationary.

IMPORTANT: Before driving the vehicle, secure all loose items in the cab so that they will not fly forward during a full brake application. Make sure all passengers are wearing seat belts.

During normal brake stops, depress the foot brake control pedal until braking action slows down the vehicle. Increase or decrease the pressure on the pedal so that the vehicle comes to a smooth, safe stop. Apply the spring parking brakes by pulling the yellow parking brake knob if the vehicle is to be parked.

IMPORTANT: An air brake proportioning system may be used in tractor air brake systems when the vehicle is not equipped with antilock braking system (ABS). When operating in bobtail mode, the rear brake chambers (on which the axle load has been greatly reduced) receive reduced (proportional) air pressure, while the front axle brake chambers receive full (normal) air pressure. This results in a different brake pedal "feel," as the pedal seems to require more travel and/or effort to slow or stop the vehicle. However, the air brake proportioning system actually improves vehicle control when the tractor is in bobtail mode. When the tractor is towing a trailer, the rear brake chambers will receive full (normal) application air pressure.

When parking a vehicle attached to a trailer that does not have spring parking brakes, apply the tractor parking brakes. Chock the trailer tires before disconnecting the vehicle from the trailer.

**WARNING:**

If a trailer or combination vehicle is not equipped with spring parking brakes, do not park it by pulling out only the trailer air supply valve knob. This would apply only the trailer service brakes. If air were to bleed from the trailer brake system, the trailer brakes would release, possibly causing an unattended runaway vehicle.

Brake Controls

The trailer brake lever (hand control valve) is used for applying the trailer brakes without applying the truck or tractor service brakes. It is usually mounted on the right-hand control panel. See Fig.338, [Trailer Brake Lever](#). The valve can be partially or fully applied, but in any partially on position it will be overridden by a full application of the service brake pedal. Moving the lever down applies the trailer brakes, while moving it up releases the trailer brakes. The lever will automatically return to the up position when it is released.

**WARNING:**

Do not use the trailer service brakes for parking; they are not designed for this purpose. If air bleeds out of the trailer air tank during parking, the vehicle could roll, causing serious personal injury or property damage.

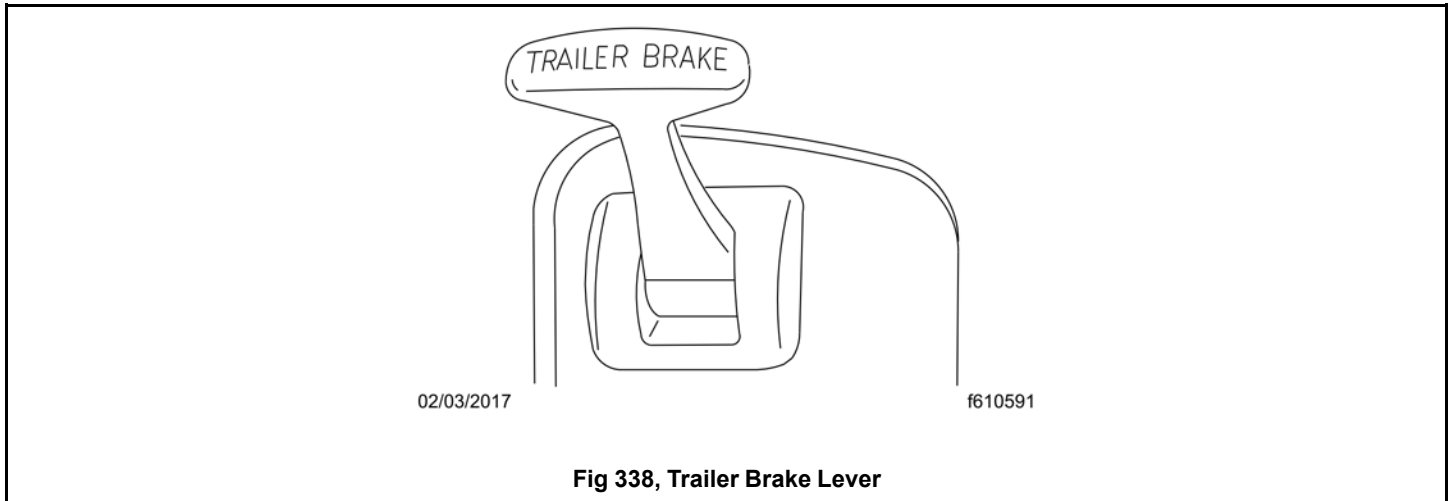

The red octagonal-shaped knob in the control panel actuates the trailer air supply valve. See Fig.339, [Brake Valve Knobs](#). After the vehicle's air hoses are connected to a trailer and the pressure in both air systems is at least 100 psi (690 kPa), the trailer air supply valve must be pushed in prior to driving the vehicle. It should stay in to charge the trailer air supply system and to release the trailer spring parking brakes.

Pull the trailer air supply valve out before disconnecting a trailer or when operating a vehicle without a trailer.

If pressure in both air systems drops to 20 to 45 psi (138 to 310 kPa), the red trailer air supply valve and yellow parking brake valve automatically pop out, applying both the tractor and trailer spring parking brakes. If the trailer is not equipped with spring parking brakes, the trailer service brakes are applied.

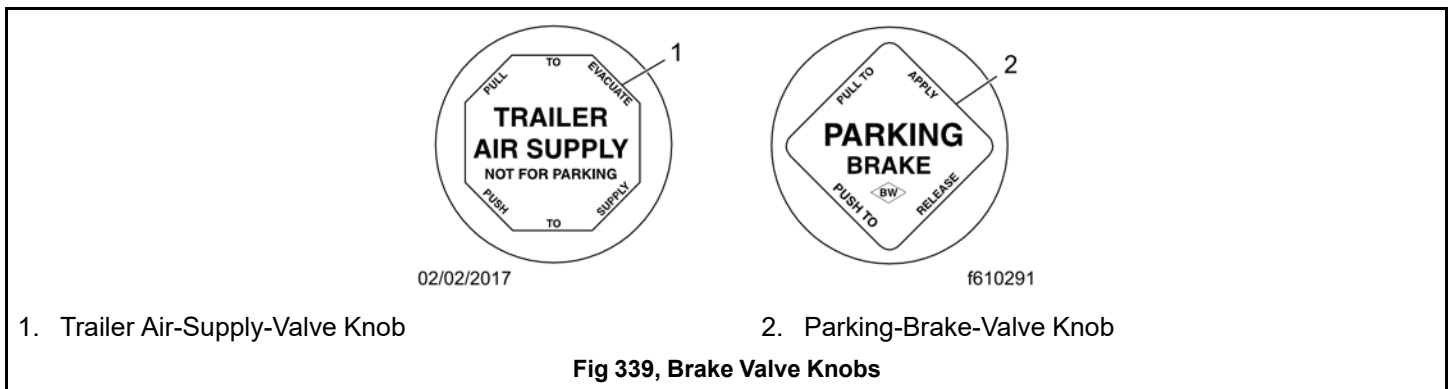

The yellow diamond-shaped knob in the control panel actuates the parking brake valve. See Fig.339, [Brake Valve Knobs](#). Pulling out the parking brake valve applies both the tractor and trailer spring parking brakes and automatically causes the trailer air supply valve to pop out. Pushing in the parking brake valve releases the tractor parking brakes.



NOTICE:

Do not use the spring parking brakes if the service brakes are hot, such as after descending a steep grade. To do so could damage the brakes. Allow hot brakes to cool before using the spring parking brakes.

Do not use the spring parking brakes during freezing temperatures if the service brakes are wet. To do so could cause them to freeze. If the brakes are wet, drive the vehicle in low gear and lightly apply the brakes to heat and dry them.

If the trailer is not equipped with spring parking brakes, pulling out the parking brake valve applies the tractor spring parking brakes and the trailer service brakes. When the tractor and trailer parking brakes (or trailer service brakes) are both applied,

the trailer brakes are released by pushing in the trailer air supply valve, leaving the tractor parking brakes applied. Air pressure in the primary or secondary reservoir must be at least 65 psi (447 kPa) before the tractor spring parking brakes, or the trailer service or spring parking brakes, can be released.

16.01.03 Automatic Slack Adjusters

Automatic slack adjusters should never be manually adjusted except during routine maintenance of the foundation brakes (e.g., replacing shoes), during slack adjuster installation, or in an emergency situation.

When the brake pushrod stroke exceeds the legal brake adjustment limit on a vehicle, there is likely a mechanical problem with the foundation brake components or the adjuster is improperly installed.

Visit a repair facility as soon as possible when brakes equipped with automatic slack adjusters are determined to be out of adjustment.



WARNING:

Manually adjusting an automatic slack adjuster to bring the pushrod stroke within legal limits is likely masking a mechanical problem. Adjustment is not a repair. Before adjusting an automatic slack adjuster, troubleshoot the foundation brake system and inspect it for worn or damaged components. Improperly maintaining the vehicle braking system may lead to brake failure, resulting in property damage, personal injury, or death.

16.02 Meritor WABCO® Antilock Braking System

16.02.01 General Description

The Meritor WABCO Antilock Braking System (ABS) is an electronic wheel speed monitoring and control system that works with the standard air brake system. ABS passively monitors vehicle wheel speed at all times, and controls wheel speed during emergency stops.



NOTICE:

An accumulation of road salt, dirt, or debris on the ABS tone wheels and sensors can cause the ABS warning light to come on. If the ABS light does come on, the tone rings and sensors should be inspected for corrosion and serviced if necessary. The service should include cleaning of the tone rings and sensors. If any tone ring on a vehicle shows severe corrosion, all tone rings on that vehicle should be replaced.

During winter months in areas where corrosive materials are used on the highways, periodically clean the underside of the vehicle, including the tone rings and sensors, to ensure proper ABS function and to protect the components from corrosion. Clean more frequently when unusually corrosive chemicals are being used.

IMPORTANT: For proper ABS system operation, do not change tire sizes. The sizes of the tires installed during production are programmed into the electronic control unit. Installing different-sized tires could result in a reduced braking force, leading to longer stopping distances.

ABS includes signal-generating tone wheels and sensors located in the wheel hubs of each sensed wheel. The sensors transmit vehicle wheel speed information to an electronic control unit, located in the vehicle electronics bay. The control unit's main circuit interprets the speed sensor signals and calculates wheel speed, wheel retardation, and a vehicle reference speed. If the calculations indicate wheel lockup, the main circuit signals the appropriate modulator valve to reduce braking pressure. During emergency braking, the modulator valve alternately reduces, increases, or maintains air pressure supply in the brake chamber to prevent front and rear wheel lockup.

The electronic control unit (ECU) also has a safety circuit that constantly monitors the wheel sensors, traction control valve (if equipped), modulator valves, and the electrical circuitry.

The Meritor WABCO ABS combines one front-axle control channel with one rear-axle control channel to form one control circuit. For example, the sensor and modulator valve on the left-front axle form a control circuit with the sensor and modulator valve on the right-rear axle. If, during vehicle operation, the safety circuit senses a failure in any part of the ABS, the driver display presents an ABS warning, the tractor warning lamp (TRACTOR ABS) illuminates, and the control circuit where the failure occurred is switched to normal braking action. See Table.38, [Brake System Warnings, Indicators, and Messages](#). The remaining control circuit will retain the ABS effect. Even if the ABS is completely inoperative, normal braking ability is maintained. An exception would be if a modulator valve (or combination modulator valve) is damaged and inoperative. As these components are an integral part of the air brake system, normal braking may be impaired or inoperative.







| Brake System Warnings, Indicators, and Messages | | | | |
|---|-------|------------------------------------|---|---|
| Telltale | Color | Description | | Driver Display |
|  | Red | Low Air Pressure (EPA10 and Newer) | Indicates air pressure in the primary or secondary reservoir has dropped below approximately 70 psi (483 kPa). A buzzer will also sound if the park brake is released or if the vehicle is moving—depending on vehicle options. |  06/30/2016 f611429 |
|  | Red | Parking Brake (EPA10 and Newer) | Indicates the parking brake is engaged. | N/A |
|  | Amber | Vehicle ABS | Momentary illumination indicates the vehicle ABS is engaged. Solid illumination indicates a problem with the vehicle ABS. Repair the ABS immediately to ensure full braking capability. | N/A |
|  | Amber | Trailer ABS | Momentary illumination indicates the trailer ABS is engaged. Solid illumination indicates a problem with the trailer ABS. Repair the ABS immediately to ensure full braking capability. | N/A |
|  | Amber | Stability Event | Flashing indicates a stability event has been detected, and the ESC system is active. Solid illumination indicates a problem with the stability system. Repair the ESC system immediately to ensure full stability capability. For more information on the ESC system, see 8.01.01 General Description, Standard Adaptive Cruise Control . | N/A |
|  | Amber | Wheel Spin Event | Flashing indicates a wheel spin event has been detected, and the ATC system is active. | N/A |

Table 38, Brake System Warnings, Indicators, and Messages



| Brake System Warnings, Indicators, and Messages | | | | |
|---|-------|-----------------|---|--|
| Telltale | Color | Description | | Driver Display |
|  | | ATC Deactivated | Indicates the ATC SPIN button has been pressed to allow wheel slip. |  10/24/2017 f611457c |
|  | Green | Engine Brake | Indicates the engine brake is enabled. | N/A |

Table 37, Brake System Warnings, Indicators, and Messages

During emergency or reduced-traction stops, fully depress the brake pedal until the vehicle comes to a safe stop. **Do not pump the brake pedal.** With the brake pedal fully depressed, the ABS will control all wheels to provide steering control and a reduced braking distance.

Although the ABS improves vehicle control during emergency braking situations, the driver still has the responsibility to change driving styles depending on existing traffic and road conditions. For example, the ABS cannot prevent an accident if the driver is speeding or following too closely.

16.02.02 Trailer ABS Compatibility

The Meritor WABCO ABS is designed to communicate with a trailer ABS, if they are compatible. Compatibility will result in the illumination of the TRAILER ABS lamp during vehicle start-up and fault detection. See Table.39, [Brake System Warnings, Indicators, and Messages](#).

The TRAILER ABS lamp will not illuminate unless a compatible trailer is connected to the tractor. The dash-mounted lamp will operate as follows when a compatible trailer is properly connected to the tractor:





| Brake System Warnings, Indicators, and Messages | | | | |
|---|-------|------------------------------------|--|---|
| Telltale | Color | Description | | Driver Display |
|  | Red | Low Air Pressure (EPA10 and Newer) | Indicates air pressure in the primary or secondary reservoir has dropped below approximately 70 psi (483 kPa). A buzzer will also sound if the park brake is released or if the vehicle is moving—depending on vehicle options. |  06/30/2016 f611429 |
|  | Red | Parking Brake (EPA10 and Newer) | Indicates the parking brake is engaged. | N/A |
|  | Amber | Vehicle ABS | Momentary illumination indicates the vehicle ABS is engaged. | N/A |

Table 39, Brake System Warnings, Indicators, and Messages







| Brake System Warnings, Indicators, and Messages | | | | |
|---|-------|------------------|---|---|
| Telltale | Color | Description | | Driver Display |
| | | | Solid illumination indicates a problem with the vehicle ABS. Repair the ABS immediately to ensure full braking capability. | |
|  | Amber | Trailer ABS | Momentary illumination indicates the trailer ABS is engaged. Solid illumination indicates a problem with the trailer ABS. Repair the ABS immediately to ensure full braking capability. | N/A |
|  | Amber | Stability Event | Flashing indicates a stability event has been detected, and the ESC system is active. Solid illumination indicates a problem with the stability system. Repair the ESC system immediately to ensure full stability capability. For more information on the ESC system, see 8.01.01 General Description, Standard Adaptive Cruise Control . | N/A |
|  | Amber | Wheel Spin Event | Flashing indicates a wheel spin event has been detected, and the ATC system is active. | N/A |
|  | | ATC Deactivated | Indicates the ATC SPIN button has been pressed to allow wheel slip. |  10/24/2017 f611457c |
|  | Green | Engine Brake | Indicates the engine brake is enabled. | N/A |

Table 38, Brake System Warnings, Indicators, and Messages

- When the ignition key is turned to the ON position, the TRAILER ABS lamp will illuminate momentarily, then turn off.
- If the lamp illuminates momentarily during vehicle operation, then shuts off, a fault was detected and corrected.
- If the lamp illuminates and stays on during vehicle operation, there is a fault with the trailer ABS. Repair the trailer ABS system immediately to ensure full antilock braking capability.

IMPORTANT: If a compatible trailer is connected, and the lamp is not illuminating momentarily when the ignition key is turned to the ON position, it is possible that the lamp is burnt out.

16.02.03 Automatic Traction Control

Vehicles with electronic engines and ABS may have Automatic Traction Control (ATC). On these vehicles, the ATC system automatically limits wheel spin during reduced-traction situations. In normal braking applications, the standard air brake system is in effect.

An additional solenoid valve is installed. During reduced-traction situations, the ATC solenoid valve controls air pressure to the modulator valves and they in turn increase, hold, or reduce pressure to the appropriate brake chambers to provide better traction whenever wheel spin occurs.

When the ATC system is in the NORMAL mode, it will apply gentle braking to the spinning wheel, to feed power to the wheel(s) with better traction. If both wheels are spinning, the system will signal the engine to reduce power.

If the system detects wheel spin or a stability event, the wheel spin/stability telltale illuminates and an alert is shown on the driver display. See Table.40, [Brake System Warnings, Indicators, and Messages](#).







| Brake System Warnings, Indicators, and Messages | | | | |
|---|-------|------------------------------------|---|---|
| Telltale | Color | Description | | Driver Display |
|  | Red | Low Air Pressure (EPA10 and Newer) | Indicates air pressure in the primary or secondary reservoir has dropped below approximately 70 psi (483 kPa). A buzzer will also sound if the park brake is released or if the vehicle is moving—depending on vehicle options. |  06/30/2016 f611429 |
|  | Red | Parking Brake (EPA10 and Newer) | Indicates the parking brake is engaged. | N/A |
|  | Amber | Vehicle ABS | Momentary illumination indicates the vehicle ABS is engaged. Solid illumination indicates a problem with the vehicle ABS. Repair the ABS immediately to ensure full braking capability. | N/A |
|  | Amber | Trailer ABS | Momentary illumination indicates the trailer ABS is engaged. Solid illumination indicates a problem with the trailer ABS. Repair the ABS immediately to ensure full braking capability. | N/A |
|  | Amber | Stability Event | Flashing indicates a stability event has been detected, and the ESC system is active. Solid illumination indicates a problem with the stability system. Repair the ESC system immediately to ensure full stability capability. For more information on the ESC system, see 8.01.01 General Description, Standard Adaptive Cruise Control . | N/A |
|  | Amber | Wheel Spin Event | Flashing indicates a wheel spin event has been detected, and the ATC system is active. | N/A |

Table 40, Brake System Warnings, Indicators, and Messages

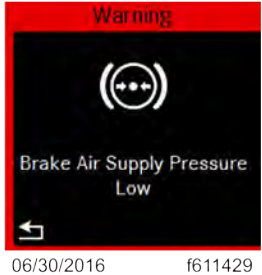

| Brake System Warnings, Indicators, and Messages | | | | |
|---|-------|-----------------|---|---|
| Telltale | Color | Description | | Driver Display |
|  | | ATC Deactivated | Indicates the ATC SPIN button has been pressed to allow wheel slip. |  |
|  | Green | Engine Brake | Indicates the engine brake is enabled. | N/A |

Table 39, Brake System Warnings, Indicators, and Messages

Pressing the ATC SPIN switch (see Fig.340, [ATC SPIN Switch](#)) shuts ATC off and allows drive wheel spin. An alert is shown on the driver display. Pressing the switch again, or cycling the ignition key, will cycle the system back to normal operation.

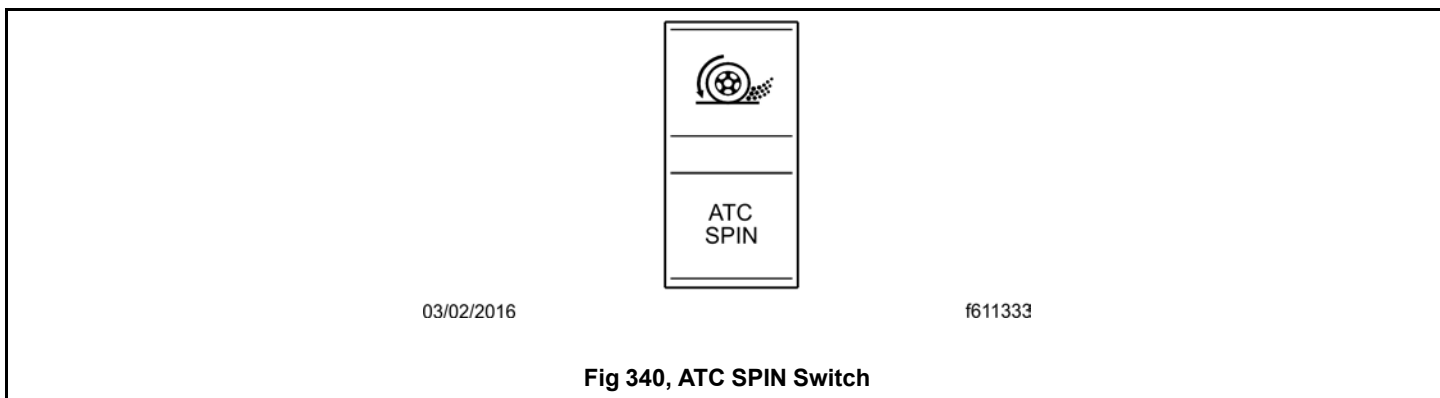

NOTICE:

The ATC spin feature is intended to be used under specific slippery conditions that require momentary increased wheel spin. Using this option for an extended period of time may damage the vehicle brake system.

After the ignition switch is turned on, the TRACTOR ABS lamp comes on for about three seconds. After three seconds, the warning light goes out if all of the tractor's ABS components are working.

IMPORTANT: If the ABS warning light does not work as described above, or comes on while driving, repair the ABS immediately to ensure full antilock braking capability.

16.02.04 ECAS Automatic Load Transfer (ECAS only)

On vehicles equipped with Electronically Controlled Air Suspension (ECAS), ECAS works in conjunction with ABS. When wheel slippage is detected by the ABS, the ECAS system transfers weight from the tag axle to the drive axle by changing air pressures in the suspension air bellows, increasing drive wheel traction.

The ECAS load transfer feature is optimized to apply the maximum available vehicle load on the drive axle, up to the maximum allowable limit, determined by the gross axle weight rating (GAWR). In bobtail or with a loaded trailer less than the

GAWR, the tag axle supports a negligible load while the drive axle supports nearly the full weight. Above the GAWR, the drive axle is loaded with approximately the maximum allowable load and the tag supports the remainder.

On vehicles equipped with the ICUC, when load transfer mode is active, "Load Transfer" will display in the message field of the driver display. See Fig.341, [Load Transfer Notification, ICUC](#).



Fig 341, Load Transfer Notification, ICUC

Load transfer mode will automatically deactivate when the vehicle reaches 45 mph (72 kmh).

16.03 Engine Brake

16.03.01 General Description

Each engine manufacturer uses a specific engine brake for their engine. Regardless of the manufacturer, the engine brake is operated with the principles outlined in here. Refer to the engine manufacturer's operation manual for details of their particular engine brake product.



WARNING:

To avoid injury from loss of vehicle control, do not activate the engine brake system under the following conditions:

- **on wet or slippery pavement, unless the vehicle is equipped with antilock braking system (ABS) and you have had prior experience driving under these conditions;**
- **when driving without a trailer or pulling an empty trailer;**
- **if the tractor drive wheels begin to lock, or there is fishtail motion after the engine brake is activated.**

NOTE: When the engine brake is enabled, the engine brake lamp illuminates in the ICU. See Table.41, [Brake System Warnings, Indicators, and Messages](#).











| Brake System Warnings, Indicators, and Messages | | | | |
|---|-------|------------------------------------|---|--|
| Telltale | Color | Description | | Driver Display |
|  | Red | Low Air Pressure (EPA10 and Newer) | Indicates air pressure in the primary or secondary reservoir has dropped below approximately 70 psi (483 kPa). A buzzer will also sound if the park brake is released or if the vehicle is moving—depending on vehicle options. |  06/30/2016 f611429 |
|  | Red | Parking Brake (EPA10 and Newer) | Indicates the parking brake is engaged. | N/A |
|  | Amber | Vehicle ABS | Momentary illumination indicates the vehicle ABS is engaged. Solid illumination indicates a problem with the vehicle ABS. Repair the ABS immediately to ensure full braking capability. | N/A |
|  | Amber | Trailer ABS | Momentary illumination indicates the trailer ABS is engaged. Solid illumination indicates a problem with the trailer ABS. Repair the ABS immediately to ensure full braking capability. | N/A |
|  | Amber | Stability Event | Flashing indicates a stability event has been detected, and the ESC system is active. Solid illumination indicates a problem with the stability system. Repair the ESC system immediately to ensure full stability capability. For more information on the ESC system, see 8.01.01 General Description, Standard Adaptive Cruise Control . | N/A |
|  | Amber | Wheel Spin Event | Flashing indicates a wheel spin event has been detected, and the ATC system is active. | N/A |
|  | | ATC Deactivated | Indicates the ATC SPIN button has been pressed to allow wheel slip. |  10/24/2017 f611457c |
|  | Green | Engine Brake | Indicates the engine brake is enabled. | N/A |

Table 40, Brake System Warnings, Indicators, and Messages

Whenever vehicle braking is required on good road conditions, the engine brake may be used in conjunction with the service brakes. There is no time limit for operation of the engine brake. However, an engine brake does not provide the precise control of, and is not a substitute for, service brakes.

**WARNING:**

Usage of the engine brake as the primary braking system can cause unpredictable stopping distances, that could result in personal injury or property damage. Service brakes are the primary vehicle braking system.

Since the engine brake is most effective at rated engine speed, gear selection is very important. Gearing down the vehicle within the limits of the rated engine speed makes the engine brake more effective. Recommended engine braking speed is above 1800 rpm and below the rated speed.

"Control speed" is the speed at which the engine brake performs 100 percent of the required downhill braking, resulting in a constant speed of descent. The control speed varies, depending on vehicle weight and the downhill grade.

For faster descent, select a higher gear than that used for control speed. Service brakes must then be used intermittently to prevent engine overspeed and to maintain desired vehicle speed.

For slower descent, select a lower gear, being careful not to overspeed the engine. Occasional deactivation of the engine brake may be necessary to maintain the designated road speed under these conditions.

If the engine is equipped with both cruise control and an engine brake, the engine brake can operate automatically while cruise control is activated. The maximum amount of braking is selected with the engine brake control. When the vehicle returns to the set cruise speed, the engine brake will turn off.

The engine brake will only operate when the accelerator and clutch pedals are fully released.

ABS has the ability to turn the engine brake off if wheel slip is detected. The engine brake will automatically turn back on once wheel slip is no longer detected.

16.03.02 Operation of the Engine Brake

**NOTICE:**

Do not allow the engine to exceed its governed speed, or serious engine damage could result.

NOTE: Depending on the brake type, the engine brake may be disabled when engine temperature falls below a set level.

The engine brake control is located on the right-hand steering column lever. At the top position, the engine brake is off, and at the three lower positions, the engine brake is on and the intensity (low, medium, high) increases with each step down. See Fig.342, [Engine Brake Positions, Right-Hand Steering Column Lever](#).

NOTE: The cruise control system and safety systems may activate the engine brake regardless of the lever position.

NOTE: On vehicles equipped with a Detroit automated transmission, setting the engine brake with the cruise control set activates Deceleration Mode. Setting the cruise control while the engine brake is on activates Descent Control Mode. For information on these modes, see "Cruise Control", see [8.01.01 General Description, Standard Adaptive Cruise Control](#).

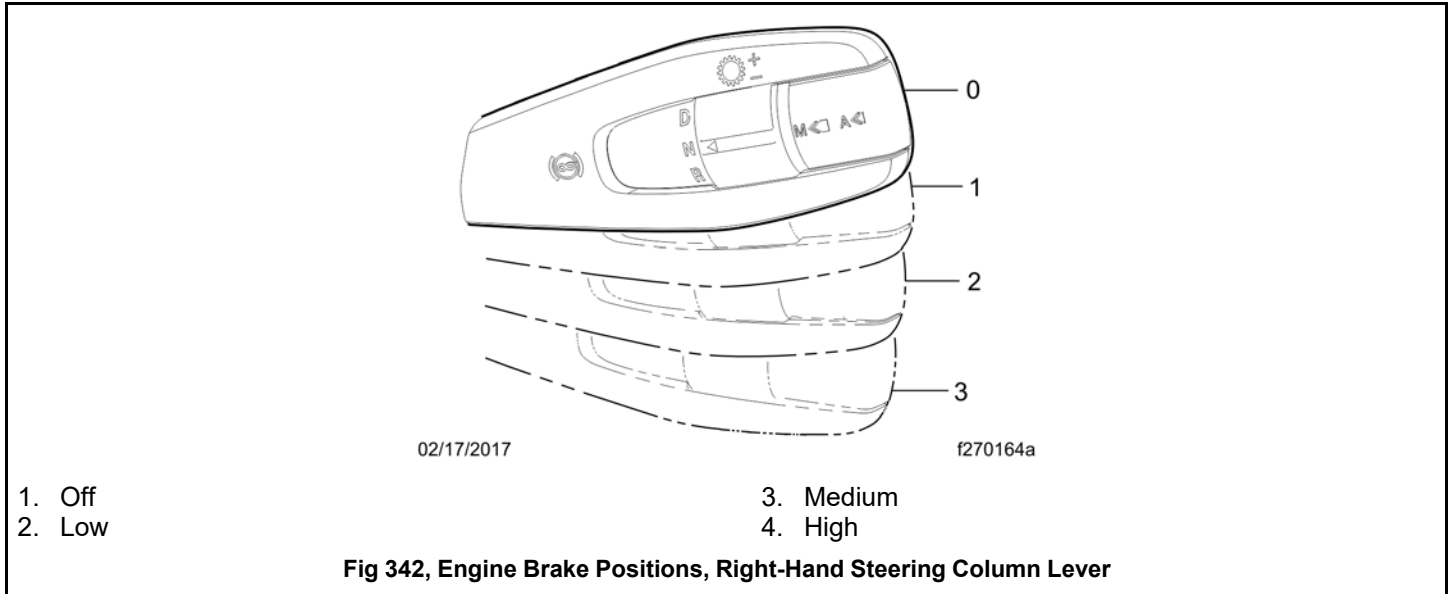

17.01 Power Steering System 404

17. Steering System

17.01 Power Steering System

The power steering system includes the power steering gear, hydraulic hoses, power steering pump, reservoir, steering wheel and column, and other components.

The power steering pump, driven by the engine, provides the power assist for the steering system. If the engine is not running, there is no power assist.

**WARNING:**

Driving the vehicle without the power-assist feature of the steering system requires much greater effort, especially in sharp turns or at low speeds, which could result in an accident and possible injury.

If the power-assist feature does not work due to hydraulic fluid loss, steering pump damage, or another cause, bring the vehicle to a safe stop. Do not drive the vehicle until the cause of the problem has been corrected.

**NOTICE:**

Never steam clean or high-pressure wash the steering gear. Internal damage to gear seals, and ultimately the steering gear, can result.

Drivers should carefully use the power available with a power steering system. If the front tires become lodged in a deep hole or rut, drive the vehicle out instead of using the steering system to lift the tires out of the hole.

**NOTICE:**

Avoid turning the tires when they are against a curb, as this places a heavy load on steering components and could damage them.

| | |
|--|-----|
| 18.01 Automated/Automatic Transmission Shift Control..... | 407 |
| 18.01.01 General Description | 407 |
| 18.01.02 Direction Switch | 409 |
| 18.01.03 Mode Switch..... | 410 |
| 18.01.04 Gear Switch..... | 411 |
| 18.01.05 Engine Brake | 414 |
| 18.01.06 Power Up and Shift into Gear | 414 |
| 18.01.07 Gear Display..... | 415 |
| 18.01.08 Selected Gear (Detroit and Eaton Transmissions)..... | 415 |
| 18.01.09 Suggested Shift (Detroit and Eaton Transmissions) | 415 |
| 18.02 Detroit™ Automated Transmissions (DT12)..... | 415 |
| 18.02.01 DT12 General Description | 415 |
| 18.02.02 Driving Modes..... | 415 |
| 18.02.03 eCoast | 416 |
| 18.02.04 Creep Mode..... | 418 |
| 18.02.05 Hill Start Aid (HSA)..... | 419 |
| 18.02.06 Protection of Clutch Abuse..... | 419 |
| 18.02.07 Engine Overspeed Alerts | 420 |
| 18.02.08 Descent Control Mode | 420 |
| 18.02.09 Hill Descent Upshift Feature..... | 421 |
| 18.02.10 Transmission Low Air Warning | 421 |
| 18.02.11 Clutch Abuse Alerts and Protections | 422 |
| 18.02.12 Auto Neutral Feature | 423 |
| 18.03 Eaton Automated Transmissions | 423 |
| 18.03.01 Eaton Automated Transmissions, General Description..... | 423 |
| 18.03.02 Automatic Mode (A)..... | 424 |
| 18.03.03 Manual Mode (M)..... | 425 |
| 18.03.04 Low (L)..... | 425 |
| 18.03.05 Clutch Abuse Protection | 425 |
| 18.03.06 Creep Mode..... | 426 |
| 18.03.07 Hill Start Aid..... | 426 |

| | |
|---|-----|
| 18.03.08 Shifting the Shuttle | 426 |
| 18.03.09 Auto Start Gear Selection and Override | 426 |
| 18.03.10 Shifting the Skip | 426 |
| 18.03.11 Automatic Traction Control | 426 |
| 18.03.12 Load-Based Shifting | 427 |
| 18.03.13 Coasting | 427 |
| 18.03.14 Transmission Low Air Warning | 427 |
| 18.03.15 Transmission Prognostics | 428 |
| 18.04 Allison Automatic Transmissions | 429 |
| 18.04.01 General Information, Allison Transmissions | 429 |
| 18.04.02 Operation Tips, Allison Transmissions | 430 |
| 18.04.03 Automatic Mode (A) | 431 |
| 18.04.04 Manual Mode (M) | 431 |
| 18.04.05 Low (L) | 432 |
| 18.04.06 Transmission Prognostics | 433 |
| 18.05 Hold Function | 433 |

18. Automated and Automatic Transmissions

18.01 Automated/Automatic Transmission Shift Control

18.01.01 General Description

Vehicles with automated or automatic transmissions use the multifunction stalk switch control shown in Fig. 343, [Automated/Automatic Transmission Shift Control](#) and Fig. 344, [Engine Brake Positions](#). This control can be used to request manual shifts, change driving mode, and set engine brake levels. See Table 42, [Functionality, Automated/Automatic Transmission Shift Control](#) for an overview of control functionality.

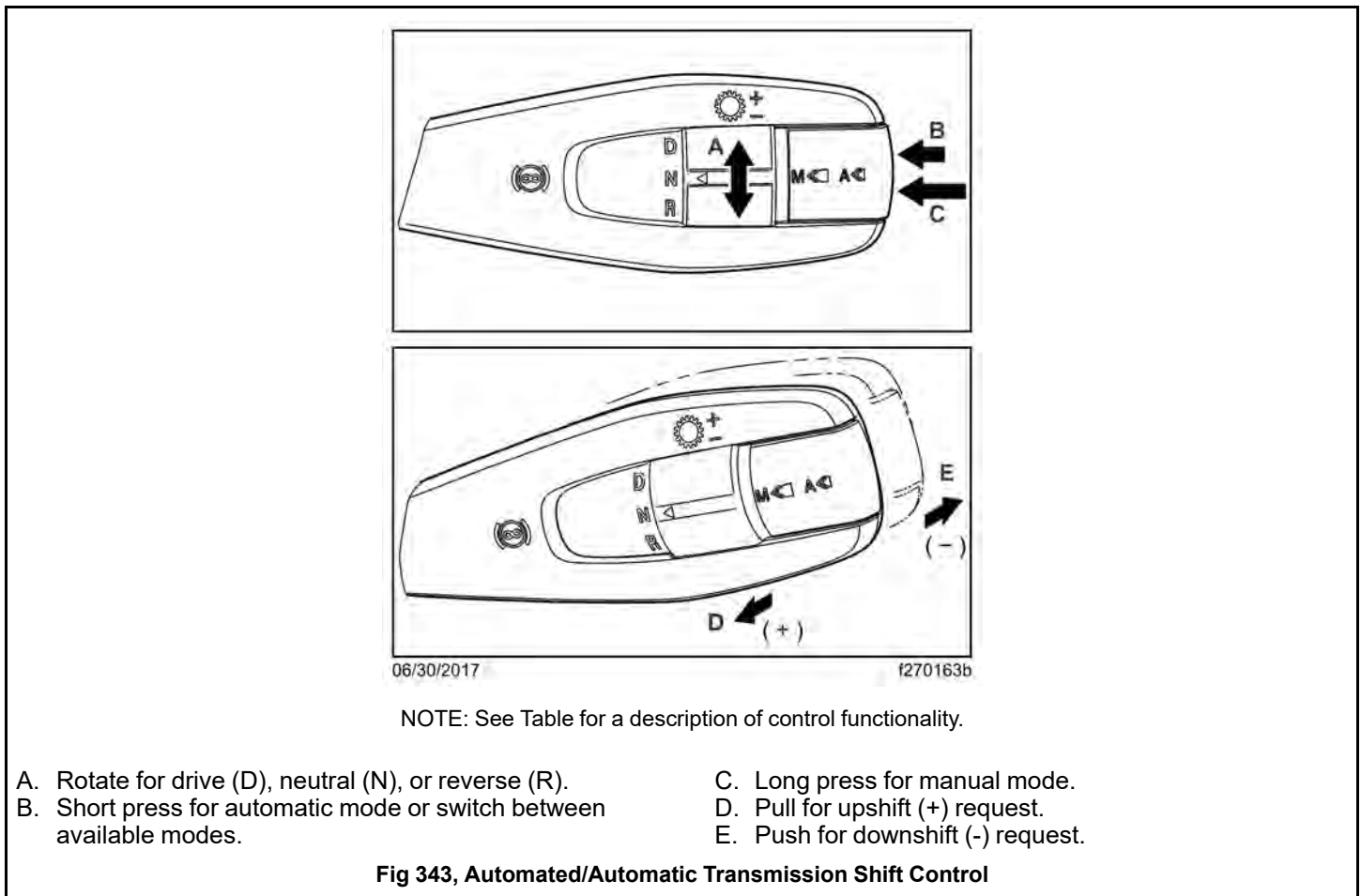

| Function/Switch | Action/Position | Request |
|-----------------|--------------------------|---------------|
| Direction | All Transmissions | |
| | D | Forward gears |
| | N | Neutral |

Table 42, Functionality, Automated/Automatic Transmission Shift Control

| Function/Switch | Action/Position | Request |
|---|---|---|
| | R | Reverse gears |
| Mode | Short press | Detroit and Eaton: Activate the automatic drive mode, or switch between available modes Allison: Switch between available shift modes. |
| | Long press | Detroit and Eaton: Activate the manual drive mode (if available) Allison: Switch between automatic and manual drive mode. |
| Gear (Detroit Automated Transmissions) | Detroit Automated Transmissions | |
| | Short pull on the lever | Upshift, single gear |
| | Pull on the lever in quick repetitions | Upshift, multiple gears |
| | Short push on the lever | Downshift, single gear |
| | Push on the lever in quick repetitions | Downshift, multiple gears |
| Gear (Eaton Automated Transmissions) | Eaton Automated Transmissions | |
| | Short pull on the lever | Upshift, single gear |
| | Pull on the lever in quick repetitions | Upshift, multiple gears |
| | Short push on the lever | Downshift, single gear |
| | Push on the lever in quick repetitions | Downshift, multiple gears |
| | While in automatic drive mode, long push on the lever | Downshift to low mode |
| | While in low mode, pull on the lever | Exits low mode and returns to automatic drive mode |
| | While in reverse mode, push on the lever | Selects deep reverse gear |
| While in deep reverse gear, pull on the lever | Upshifts to standard reverse gear | |
| Gear (Allison Automatic Transmissions) | Allison Automatic Transmissions | |
| | Short pull on the lever | Upshift, single gear |
| | Pull on the lever in quick repetitions | Upshift, multiple gears |
| | Short push on the lever | Downshift, single gear |
| | Push on the lever in quick repetitions | Downshift, multiple gears |
| | While in automatic drive mode, long push on the lever | Downshift to low mode |

Table 42, Functionality, Automated/Automatic Transmission Shift Control

| Function/Switch | Action/Position | Request |
|---------------------------|---|---|
| | While in low mode, pull on the lever | Exits low mode and returns to automatic drive mode |
| | While in reverse mode, push on the lever | Selects deep reverse gear (only on 7-speed 4000 Series transmissions) |
| | While in deep reverse gear (only on 7-speed 4000 Series transmissions), pull on the lever | Upshifts to standard reverse gear |
| Engine Brake ¹ | Engine Brake Functions | |
| | Lever at position 0 (top) | Engine brake off |
| | Lever at position 1 | Low intensity |
| | Lever at position 2 | Medium intensity |
| | Lever at position 3 (bottom) | High intensity |

1. For functions with cruise control active, see 8.01.01, page 259.

Table 41, Functionality, Automated/Automatic Transmission Shift Control

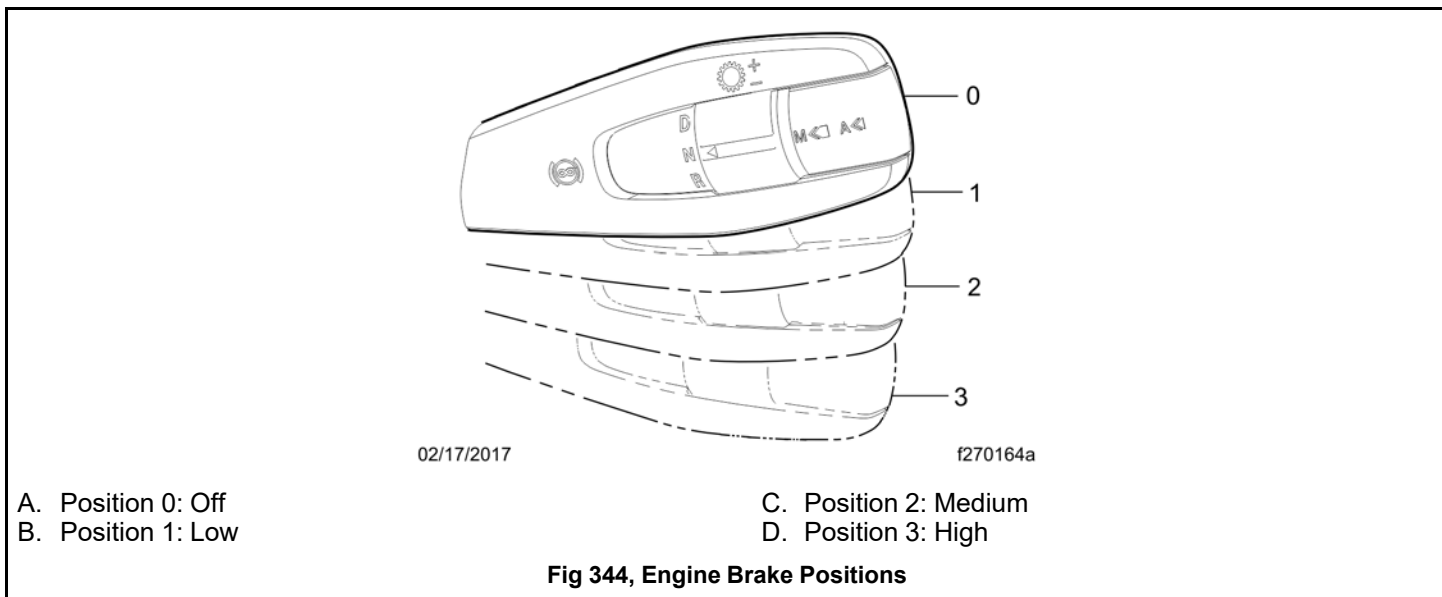

18.01.02 Direction Switch

Use the direction switch to request drive (D), neutral (N), or reverse (R). See Fig. 345, Automated/Automatic Transmission Shift Control, Ref. A.

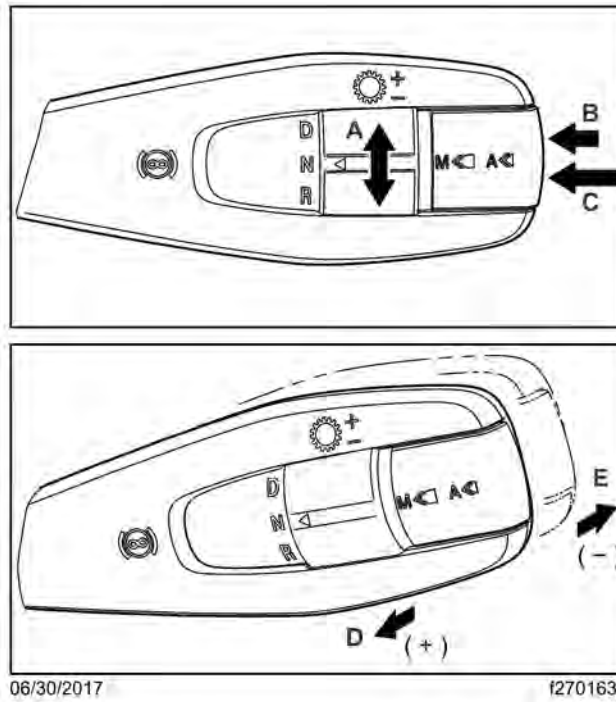

06/30/2017

f270163b

NOTE: See Table for a description of control functionality.

- | | |
|--|------------------------------------|
| A. Rotate for drive (D), neutral (N), or reverse (R). | C. Long press for manual mode. |
| B. Short press for automatic mode or switch between available modes. | D. Pull for upshift (+) request. |
| | E. Push for downshift (-) request. |

Fig 345, Automated/Automatic Transmission Shift Control

18.01.03 Mode Switch

The driving mode can be changed using the Mode switch on the shift control. See Fig. 346, [Automated/Automatic Transmission Shift Control](#), Ref. B and C.

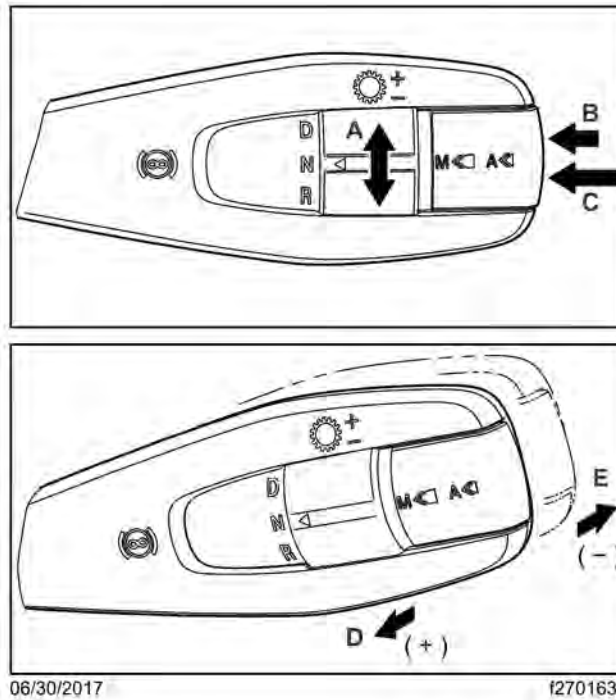

NOTE: See Table 42,, page 407 for a description of control functionality.

- | | |
|--|------------------------------------|
| A. Rotate for drive (D), neutral (N), or reverse (R). | C. Long press for manual mode. |
| B. Short press for automatic mode or switch between available modes. | D. Pull for upshift (+) request. |
| | E. Push for downshift (-) request. |

Fig 346, Automated/Automatic Transmission Shift Control

18.01.04 Gear Switch

For automated and automatic transmissions, gear shifts can be requested manually; push the lever away to request a downshift, or pull the lever toward you to request an upshift (see Fig. 347, [Automated/Automatic Transmission Shift Control](#), Ref. D and E). See Table 43, [Functionality, Automated/Automatic Transmission Shift Control](#) for more information about upshift and downshift requests.

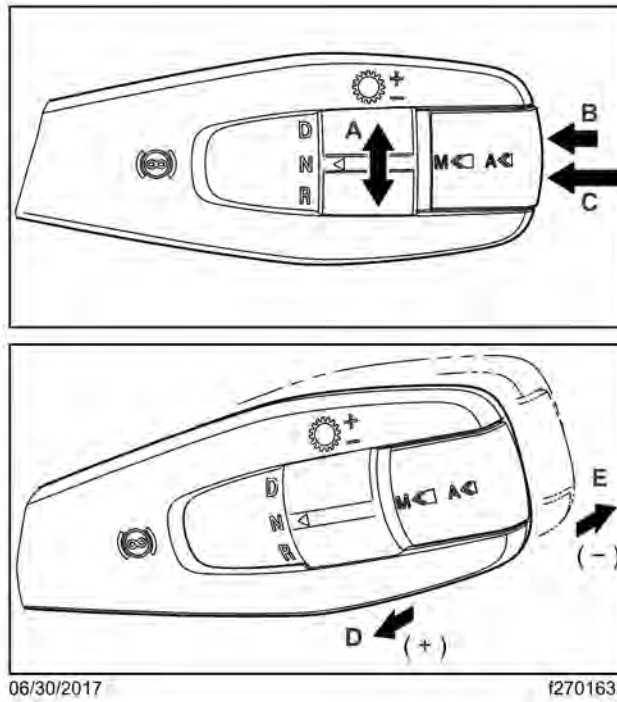

NOTE: See Table 43,, page 412 for a description of control functionality.

- A. Rotate for drive (D), neutral (N), or reverse (R).
- B. Short press for automatic mode or switch between available modes.
- C. Long press for manual mode.
- D. Pull for upshift (+) request.
- E. Push for downshift (-) request.

Fig 347, Automated/Automatic Transmission Shift Control

| Function/Switch | Action/Position | Request |
|---------------------------------------|--|---|
| All Transmissions | | |
| Direction | D | Forward gears |
| | N | Neutral |
| | R | Reverse gears |
| Mode | Short press | Detroit and Eaton: Activate the automatic drive mode, or switch between available modes Allison: Switch between available shift modes. |
| | Long press | Detroit and Eaton: Activate the manual drive mode (if available) Allison: Switch between automatic and manual drive mode. |
| Gear(Detroit Automated Transmissions) | Detroit Automated Transmissions | |

Table 43, Functionality, Automated/Automatic Transmission Shift Control

| Function/Switch | Action/Position | Request |
|--|---|---|
| | Short pull on the lever | Upshift, single gear |
| | Pull on the lever in quick repetitions | Upshift, multiple gears |
| | Short push on the lever | Downshift, single gear |
| | Push on the lever in quick repetitions | Downshift, multiple gears |
| Gear (Eaton Automated Transmissions) | Eaton Automated Transmissions | |
| | Short pull on the lever | Upshift, single gear |
| | Pull on the lever in quick repetitions | Upshift, multiple gears |
| | Short push on the lever | Downshift, single gear |
| | Push on the lever in quick repetitions | Downshift, multiple gears |
| | While in automatic drive mode, long push on the lever | Downshift to low mode |
| | While in low mode, pull on the lever | Exits low mode and returns to automatic drive mode |
| | While in reverse mode, push on the lever | Selects deep reverse gear |
| | While in deep reverse gear, pull on the lever | Upshifts to standard reverse gear |
| Gear (Allison Automatic Transmissions) | Allison Automatic Transmissions | |
| | Short pull on the lever | Upshift, single gear |
| | Pull on the lever in quick repetitions | Upshift, multiple gears |
| | Short push on the lever | Downshift, single gear |
| | Push on the lever in quick repetitions | Downshift, multiple gears |
| | While in automatic drive mode, long push on the lever | Downshift to low mode |
| | While in low mode, pull on the lever | Exits low mode and returns to automatic drive mode |
| | While in reverse mode, push on the lever | Selects deep reverse gear (only on 7-speed 4000 Series transmissions) |
| | While in deep reverse gear (only on 7-speed 4000 Series transmissions), pull on the lever | Upshifts to standard reverse gear |
| Engine Brake ¹ | Engine Brake Functions | |
| | Lever at position 0 (top) | Engine brake off |

Table 43, Functionality, Automated/Automatic Transmission Shift Control

| Function/Switch | Action/Position | Request |
|-----------------|------------------------------|------------------|
| | Lever at position 1 | Low intensity |
| | Lever at position 2 | Medium intensity |
| | Lever at position 3 (bottom) | High intensity |

1. For functions with cruise control active, see 8.01.01, page 259.

Table 42, Functionality, Automated/Automatic Transmission Shift Control

18.01.05 Engine Brake

The engine brake is controlled by the lever position (see Fig. 348, [Engine Brake Positions](#)). At the top position, the engine brake is off, and at the three lower positions, the engine brake is on and the intensity (low, medium, high) increases with each step down. For more information about using the engine brake, see [8.01.01 General Description, Standard Adaptive Cruise Control](#).

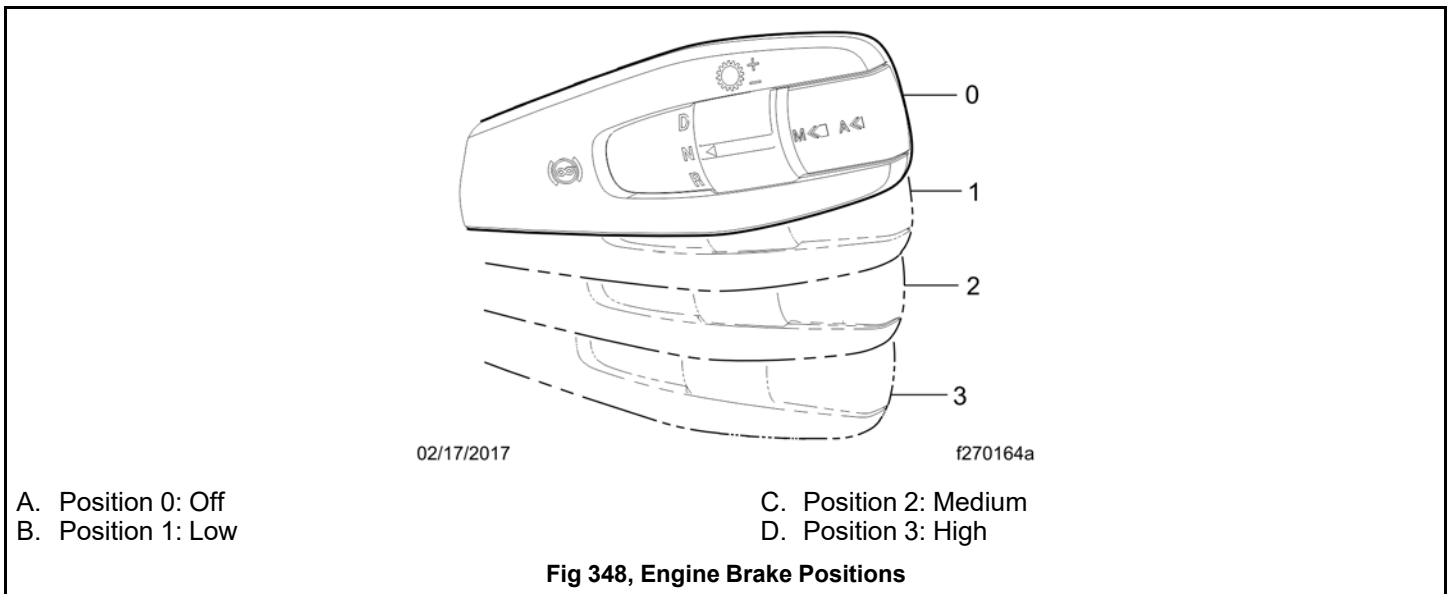

NOTE: Using the engine brake with cruise control can be used to activate Descent Control Mode or Deceleration Mode. For more information, see 'Cruise Control'.

18.01.06 Power Up and Shift into Gear

1. With the parking brake set and Neutral (N) selected on the shift control, turn the ignition switch to the ON position.
2. Start the engine.
3. Apply the service brake.
4. Select the desired starting gear.
5. Release the parking brake.
6. Release the service brake and apply the accelerator.

18.01.07 Gear Display

The current transmission gear and driving mode are displayed in the static menu at the bottom of the driver display screen. See Fig. 349, [Typical Gear Display \(Detroit and Eaton\)](#).

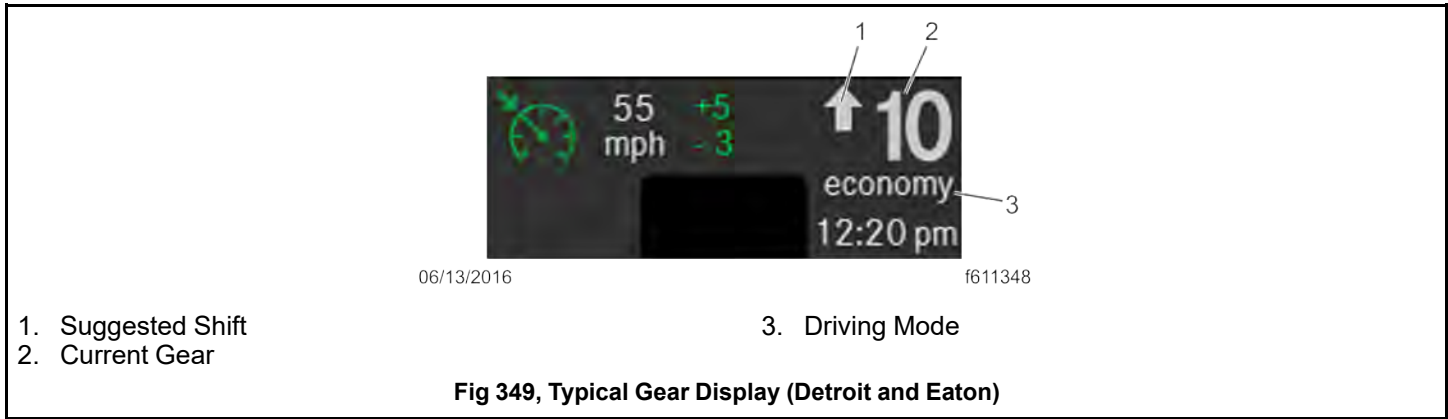

18.01.08 Selected Gear (Detroit and Eaton Transmissions)

If the selected gear is different than the current gear for longer than a half second, the current gear display will flash and the selected gear value will be shown. Once the current gear and selected gear match, the selected gear display disappears and the current gear display stops flashing.

18.01.09 Suggested Shift (Detroit and Eaton Transmissions)

In Manual mode only (if available), a suggested shift is displayed to indicate the most economical gear available. The suggested shift is the number of up or down arrows from the current gear with a maximum of three up or down arrows.

18.02 Detroit™ Automated Transmissions (DT12)

18.02.01 DT12 General Description

Detroit transmissions have twelve forward gears and up to four reverse gears that can be shifted automatically or manually. Shifting and clutch actuation are computer controlled, and there is no clutch pedal needed to operate the vehicle. Automatic shifts are selected for fuel economy or engine power. Manual shifts can be requested with the shift control and the transmission ECU grants them when conditions permit. In all cases, shifts depend on the following factors: engine speed, accelerator pedal position, service brake usage, engine brake operation, vehicle load status, and road conditions.

NOTE: To avoid potential engine stall risk or unexpected shifting, use the interaxle differential lock when the vehicle is operated in slippery conditions. See [20.01.01 General Description, Interaxle Lock and Tandem Axles](#) for information about the interaxle differential lock.

18.02.02 Driving Modes

There are three driving modes: Manual, Automatic Economy, and Automatic Performance. To activate the manual drive mode, press and hold the mode switch briefly. Press the switch quickly to activate the automatic drive mode or change between modes. See Fig. 350, [Automated/Automatic Transmission Shift Control](#).

In Automatic Economy mode, gear shifts are designed for saving fuel. In Automatic Performance mode, gear shifts are designed for higher performance and are made at higher engine speeds. In manual mode, gear shifts are requested manually.

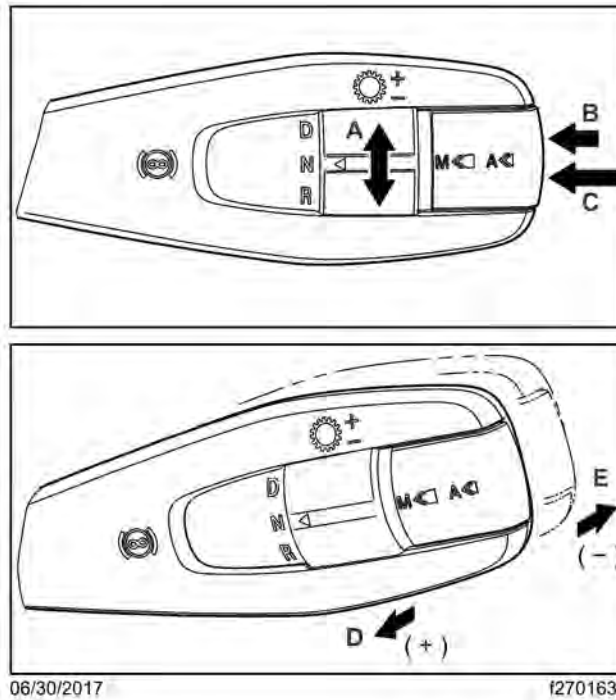

NOTE: See Table for a description of control functionality.

- | | |
|--|------------------------------------|
| A. Rotate for drive (D), neutral (N), or reverse (R). | C. Long press for manual mode. |
| B. Short press for automatic mode or switch between available modes. | D. Pull for upshift (+) request. |
| | E. Push for downshift (-) request. |

Fig 350, Automated/Automatic Transmission Shift Control

NOTE: In Automatic Performance mode, the transmission will automatically change to Automatic Economy mode if it hasn't received a request for more power in several minutes, unless current road conditions require higher engine performance.

18.02.03 eCoast

The eCoast feature can improve driving economy. When conditions permit, the transmission control automatically shifts the transmission to neutral to coast at speeds of approximately 50 mph (80 km/h) and above. However, the vehicle can coast down to 45 mph (72 km/h). An 'E' shows in the gear display when eCoast is in effect. See Fig. 351, [eCoast Display](#).

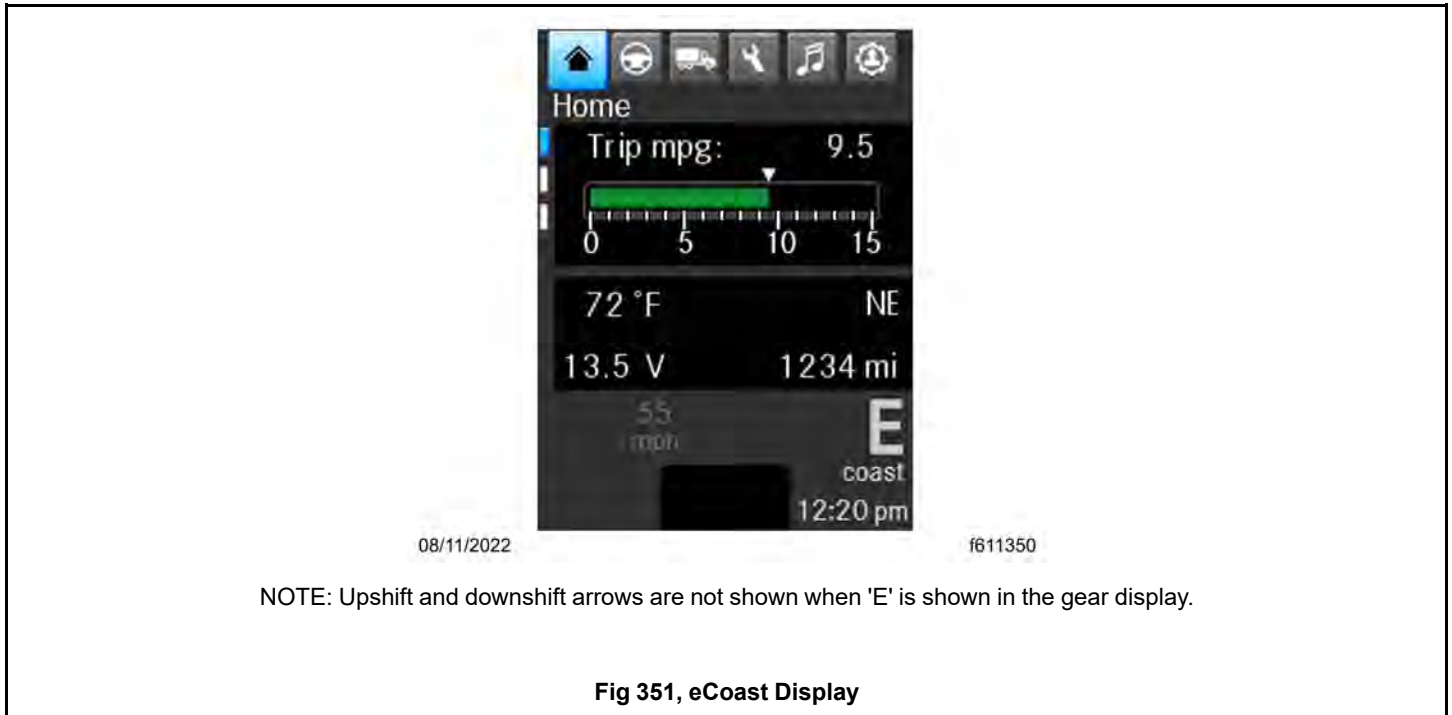

To turn eCoast on or off, navigate to the transmission settings screen. See Fig. 352, [eCoast and Creep Mode On/Off Screen](#).

The eCoast function is not active when any of the following occur:

- the accelerator pedal is pressed.
- vehicle acceleration rate is exceeded.
- the service brake pedal is pressed.
- the engine brake is in use.
- cruise control brakes or accelerates.
- vehicle speed exceeds the cruise control set speed by more than approximately 4 mph (6 km/h).
- the speed limiter is active and the maximum speed set is exceeded.
- diesel particulate filter (DPF) regeneration occurs.

NOTE: eCoast availability and the On/Off screen are customer-selectable parameters. To enable or disable eCoast, see an authorized Freightliner service facility.

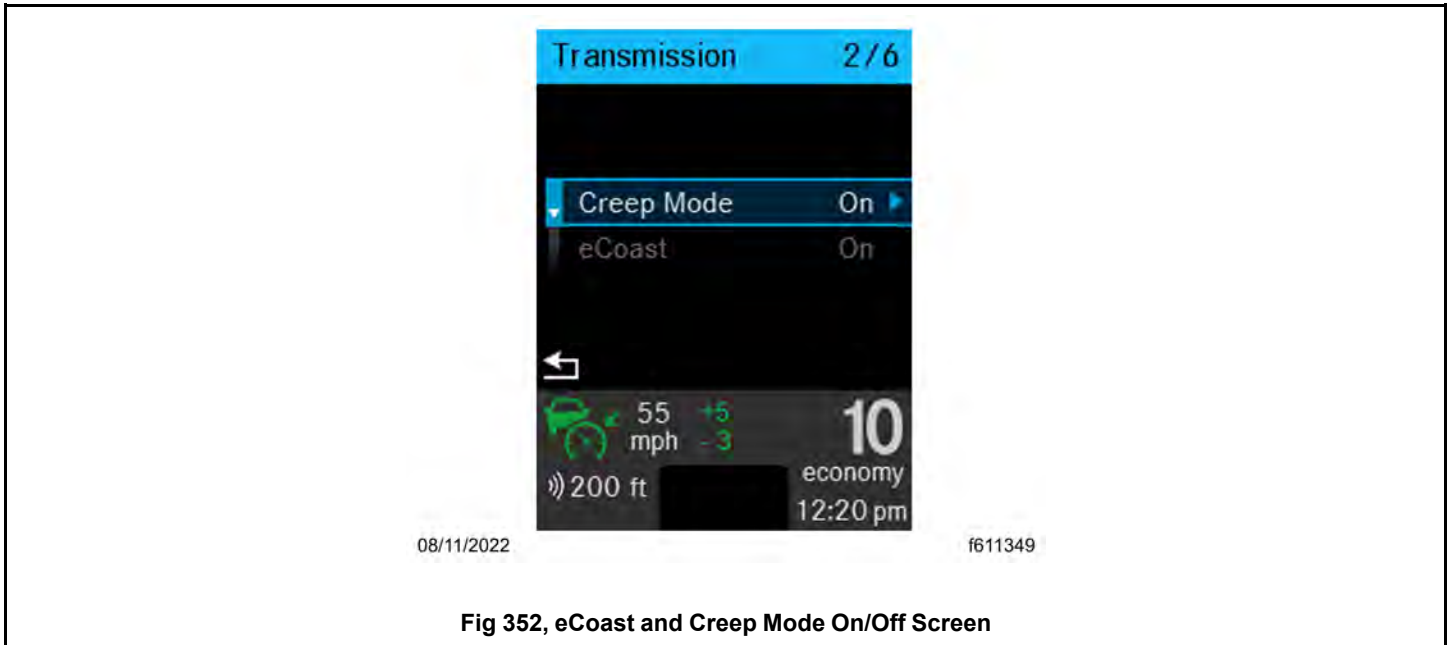

Fig 352, eCoast and Creep Mode On/Off Screen

18.02.04 Creep Mode

Creep mode allows the vehicle to be maneuvered at very slow speeds. To activate Creep mode for the first time within the current driving cycle, press the accelerator pedal to launch the vehicle, thereby modulating the clutch and allowing it to slip. Following this and for the duration of the current driving cycle, Creep mode is active.

Once the vehicle is stopped via the service brakes, the vehicle will begin to creep again, without the accelerator pedal actuation, as soon as the service brakes are released.

To begin using Creep mode (once active) from a parked position, shift from neutral to either drive or reverse, release the service brakes, and briefly depress the accelerator pedal. The vehicle's urge to move can then be felt.

If creep is active and no acceleration is achieved, then Creep mode will abort. A display message notifies the operator when Creep mode is about to be aborted.

IMPORTANT: When slowing down from higher speeds in drive or reverse, remember that Creep mode will be in effect at lower speeds. Use the service brakes to stop the vehicle.

To turn Creep Mode on or off, navigate to the transmission settings screen (if available). See Fig. 353, [eCoast and Creep Mode On/Off Screen](#).

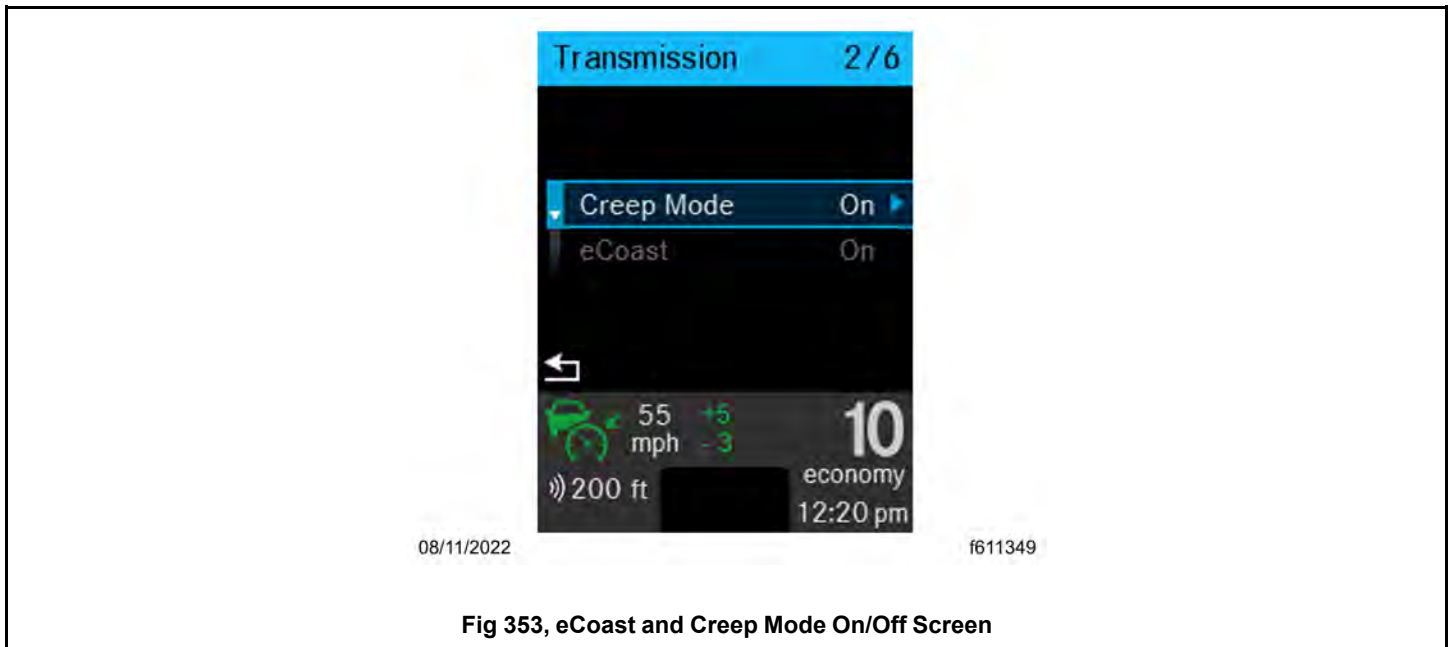

Fig 353, eCoast and Creep Mode On/Off Screen

NOTE: Creep mode availability and the On/Off screen are customer-selectable parameters. To enable or disable creep mode, see an authorized Freightliner service facility.

18.02.05 Hill Start Aid (HSA)

Detroit transmissions are equipped with a Hill Start Aid (HSA) feature to prevent rolling backward when launching the vehicle on an uphill grade. The system delays the release of service brakes until enough torque is available to begin moving the vehicle forward. The system will hold the brakes for a maximum of 3 seconds. If driveline torque is not detected, the system will audibly alert the driver and release the brakes.

HSA has an extension called the hold function, that eases the strain of driving in stop-and-go traffic. For information, see 'Hold Function.'

18.02.06 Protection of Clutch Abuse

A vehicle equipped with a Detroit transmission does not have a clutch pedal, but still has a clutch that is operated automatically and can be damaged by abusive driver actions. To protect the clutch, the vehicle has a clutch abuse protection system that alerts the driver and restricts functionality when needed. Extended periods in creep mode, slipping the clutch (using the accelerator pedal to hold the vehicle on a hill, for example), and high clutch temperatures can activate the clutch abuse protection system. A display message notifies the operator when the protections are needed.



NOTICE:

To hold the vehicle stationary on an uphill slope, use the service brakes, not the accelerator pedal. Using the accelerator pedal can overheat and damage the clutch. To start moving, use the accelerator pedal and release the brakes as the vehicle begins to move.

There are three clutch abuse protection levels. At each, the driver is alerted and functionality is modified; see Table 44, [Clutch Abuse Alerts and Protections](#).

To avoid clutch overheating, follow these tips:

- To hold the vehicle stationary on an uphill slope, use the service brakes, not the accelerator pedal.
- To start moving on an uphill slope, use the accelerator pedal and release the brakes as the vehicle begins to move.

- When hooking up to a trailer, ensure the trailer is high enough to back under, and use first gear reverse.
- Avoid starting in higher gears, and start in first gear when a trailer is attached.
- Ensure trailer brakes have had time to completely release prior to starting.
- Do not use creep mode for an extended period. Stop or adjust the vehicle speed when warned to deactivate creep mode.

18.02.07 Engine Overspeed Alerts

To help protect the engine, the system has display messages to notify the operator when the engine has exceeded certain thresholds and needs to be slowed down before significant engine damage occurs. There are two warnings, one at about 2300 rpm and another at 2500 rpm, indicated with messages and a fault code.

18.02.08 Descent Control Mode

Descent Control mode helps control the vehicle and engine speed when descending a grade.

NOTE: Before engaging Descent Control mode, determine an appropriate speed for the vehicle load and grade of the road.

To activate Descent Control mode, manually set the engine brakes with the shifter stalk and, while the engine brakes are actively working, set cruise to the desired descent speed. A Descent Control mode engaged icon will appear on the ICUC screen showing it is active. See Fig. 354, [Descent Control Mode Active](#).



The descent control mode will attempt to manage the vehicle's speed by varying the engine brake level.

The driver should be ready to intervene by applying the service brakes if the grade is too steep and the vehicle is traveling too fast. Applying the service brake to slow the vehicle will not cancel cruise control. Once the service brake is released, the vehicle speed becomes the new descent control set speed. A pop-up will appear on the instrument cluster screen to notify the driver of the new speed. See Fig. 355, [New Descent Control Mode Set Speed Pop-Up](#).



Fig 355, New Descent Control Mode Set Speed Pop-Up

When the vehicle's descent is complete, return the engine brake stalk to the OFF/Auto position. At this point the Descent Control set speed will become the new cruise speed.

18.02.09 Hill Descent Upshift Feature

NOTE: It is critical that the driver maintains complete control over the vehicle at all times. The proper speed, and gear if in manual mode, should be selected before the crest of any hill to ensure a safe descent. The driver should apply engine and service brakes appropriately during any descent.

If the feature is enabled, the Detroit™ automated transmission (DT12) is capable of upshifting automatically when descending grades. When the vehicle is descending without engine or service brake application, the DT12 will upshift at 2000 rpm. If the engine or service brake is applied during descent, the DT12 will upshift at 2400 rpm.

18.02.10 Transmission Low Air Warning



CAUTION:

If the yellow 'Caution: Transmission Air Supply Low' popup appears while the vehicle is in operation slow down, safely pull the vehicle off the road, then correct the problem.

Pneumatic controls are used to shift the transmission. If there is inadequate air pressure, a yellow caution pop-up will appear and the quality of gear shifts may be degraded. See Fig. 356, [Low Transmission Air Pressure Pop-up](#). Wait for air pressure to build before operating the vehicle.

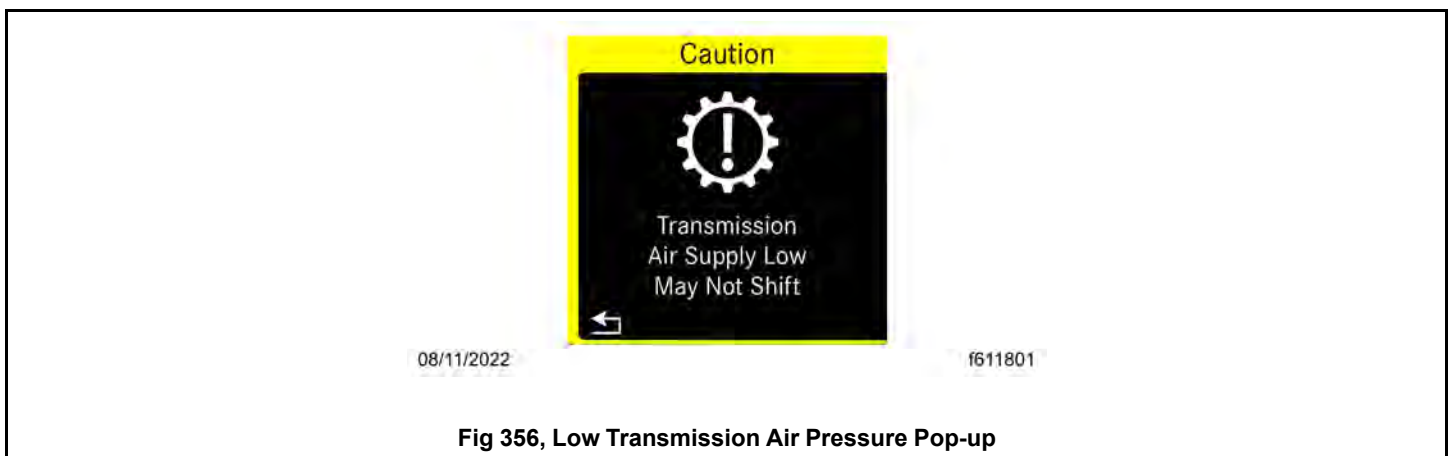

Fig 356, Low Transmission Air Pressure Pop-up



CAUTION:

If the red 'Warning: Transmission Will Not Shift' popup appears while the vehicle is in operation, choose the safest location available to pull the vehicle off the road. Prepare for the vehicle to be immobile if the problem cannot be resolved.

If a severe loss of air pressure occurs, a red warning pop-up will appear and the transmission will not shift. See Fig. 357, [No Transmission Air Pressure Pop-up](#).



Fig 357, No Transmission Air Pressure Pop-up

18.02.11 Clutch Abuse Alerts and Protections

| Alert Level | Alert | Protections | | |
|-------------|------------------------------------|--------------------|----------------|--|
| | | Highest Start Gear | Creep Mode | Clutch Function |
| 1 | Heavy clutch load message | 1 | No restriction | Normal function |
| 2 | Heavy clutch load message | 1 | Disabled | Normal function |
| 3 | Clutch overload message and buzzer | 1 | Disabled | If the accelerator pedal is depressed, the clutch closes at fixed rate. If the accelerator pedal is released, the clutch opens at fixed rate. |

Table 43, Clutch Abuse Alerts and Protections

18.02.12 Auto Neutral Feature

**WARNING:**

Do not leave the driver's seat without placing the shift stalk lever in the neutral position and applying the parking brake. Failure to do so could cause property damage and personal injury.

The auto neutral feature will shift the Detroit transmission into neutral if the drive direction switch is left in drive or reverse for an extended period of time. The driver is warned of a pending shift with a flashing 'N' in the gear position display of the instrument cluster. A brief warning buzzer will sound when the transmission shifts into neutral. See Table 45, [Direction Switch 'D' or 'R'](#) for all the conditions and indicators that are possible.

NOTE: If the auto neutral feature is activated, apply the service brake and cycle the gear direction switch into neutral, and back into the desired position.

Additionally for vehicles equipped with CPC3Evo, if the engine is shutdown without the drive direction switch in the 'N' position, the warning buzzer will provide a long duration activation, and a pop-up will prompt the driver to place the shifter into the neutral position.

**WARNING:**

If the transmission does not completely switch to neutral before engine shutdown, the engine will not restart until the transmission can complete the shift to neutral.

If neutral gear is not achieved, a pop-up encourages the driver to start the engine to allow the transmission to achieve neutral gear.

| CPC model | All | | CPC4 | CPC3Evo |
|----------------|---------------------------------|---------------------------------|-------------------------|--------------------------|
| Key Position | ON with Engine Idling | | Ignition OFF | Ignition OFF |
| Brake Position | Parking brake ON | Parking brake OFF | Parking brake ON or OFF | Parking brake ON or OFF |
| Gear Display | Flashing 'N' (short duration) | Flashing 'N' (long duration) | — | Shift into neutral |
| Warning Buzzer | Short duration activation | Short duration activation | — | Long duration activation |
| Gear Position | Neutral, when the buzzer sounds | Neutral, when the buzzer sounds | In gear or neutral | In gear or neutral |

Table 44, Direction Switch 'D' or 'R'

18.03 Eaton Automated Transmissions

18.03.01 Eaton Automated Transmissions, General Description

Eaton automated transmissions use shift selection software and electric clutch actuation; a clutch pedal is not needed to operate the vehicle. These transmissions use the multi-function stalk switch shown in Fig.

358, [Automated/Automatic Transmission Shift Control](#) to select mode, direction, neutral, low, and to make manual shifts. To know what gear the transmission is in, see the driver display. Forward shifts can be made either manually or automatically.

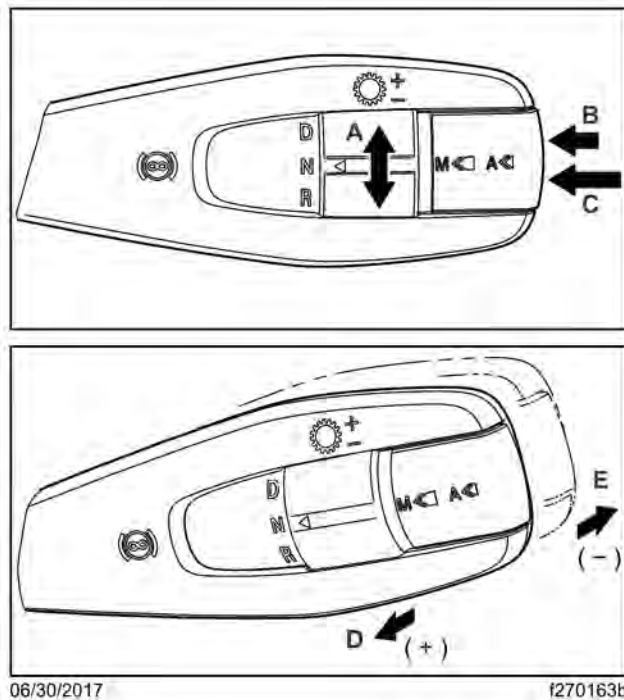

NOTE: See Table for a description of control functionality.

- | | |
|--|------------------------------------|
| A. Rotate for drive (D), neutral (N), or reverse (R). | C. Long press for manual mode. |
| B. Short press for automatic mode or switch between available modes. | D. Pull for upshift (+) request. |
| | E. Push for downshift (-) request. |

Fig 358, Automated/Automatic Transmission Shift Control

18.03.02 Automatic Mode (A)

In automatic drive mode, upshifts and downshifts are made by the transmission without driver intervention.

Use the mode switch on the shift control to select the automatic mode (A). Rotate the D/N/R switch to Drive (D), and press down on the throttle pedal. The transmission will shift automatically.

NOTE: If attempting to select a non-Neutral mode without applying the service brakes, the transmission will not shift into gear. To shift into gear, select Neutral, apply the service brakes, and select the desired mode again.

In Drive, the start gear is automatically selected. The selected start gear can vary depending on several vehicle inputs such as load, grade, and axle/transmission ratio. The start gear can be changed using the shift control, provided the selected gear would allow the vehicle to launch without damaging the transmission. If the start gear is changed using the shift control, it will be the default until the vehicle is powered down or the selection is changed again manually.

IMPORTANT: Prior to ascending a steep grade, either reduce the default start gear by one (using the shift control) or apply full throttle for the duration of the grade so the vehicle maintains the proper engine and vehicle speed during the entire grade.

In drive, the transmission automatically performs upshifts and downshifts. However, when the transmission is near the shift point, the shift can be forced using the upshift or downshift function of the shift control.

NOTE: The transmission may deny a shift while ascending or descending a grade if the load of the vehicle and grade of the terrain in combination with the drivetrain ratio and engine torque fall outside of the acceptable range to perform a shift. If the shift is denied, a tone will sound.

18.03.03 Manual Mode (M)

In manual mode, the driver requests upshifts and downshifts instead of letting the Eaton transmission select them automatically. Manual shifting may be helpful when traversing a work site, railroad tracks, or steep grades, for example.

Use the mode switch on the shift control to select the manual mode (M). To drive forward, rotate the D/N/R switch to drive (D), and press down on the throttle pedal. To shift up, pull the lever up (towards you); to shift down, push the lever down (away from you). The system holds the current gear unless a shift is requested or if the system initiates a manual mode override.

NOTE: The transmission may deny a shift while ascending or descending a grade if the load of the vehicle and grade of the terrain in combination with the drivetrain ratio and engine torque fall outside of the acceptable range to perform a shift. If the shift is denied, a tone will sound.

NOTE: If attempting to select a non-Neutral mode without applying the service brakes, the transmission will not shift into gear. To shift into gear, select Neutral, apply the service brakes, and select the desired mode again.

Manual Mode Override

The system is equipped with a manual mode override function. If the vehicle is being 'back driven' (for example, descending a grade and the engine speed is excessively high), the system will upshift automatically. Also, if the start gear is changed and it causes the engine to lug at takeoff, the system will override the current position and select the best available gear.

18.03.04 Low (L)

Use low when wanting to maximize engine braking and minimize the use of the brake pedal—for example, when driving down long grades or when coming to a stop. To select Low, push down on the multi-function stalk switch, and hold in the down-shift position for half a second or more. The lowest available start gear will be selected (the starting gear cannot be changed in low).

If low is selected while moving, the transmission will not upshift (unless the system initiates a low override). The system will downshift at the earliest opportunity to provide maximum engine braking.

NOTE: If attempting to select a non-Neutral mode without applying the service brakes, the transmission will not shift into gear. To shift into gear, select Neutral, apply the service brakes, and select the desired mode again.

Low Override

The system is equipped with a Low override function. If the vehicle is being 'back driven' (for example, descending a grade and the engine speed is excessively high), the system will upshift automatically. Also, if the start gear is changed and it causes the engine to lug at takeoff, the system will override the current position and downshift.

18.03.05 Clutch Abuse Protection

Although a vehicle equipped with an Eaton automated transmission uses an automated clutch, the clutch can still overheat and slip with improper use. The clutch abuse protection feature helps protect the clutch if the automated clutch starts to overheat. When the clutch abuse protection feature initiates and sounds a warning tone, full clutch actuation must be completed quickly. If it is not completed quickly enough, the system will either open the clutch (if the throttle pedal is not being pressed) or close the clutch (if the throttle pedal is being pressed). If the abuse continues, the system will open the clutch and take away throttle control briefly to allow the clutch to cool down.

To protect the clutch:

- Select the lowest possible start gear for the application.
- Use Creep Mode when appropriate.
- Use the service brakes and the Hill Start Aid when launching on a grade.
- Minimize the time it takes to engage the clutch from rest.
- Do not use the throttle to hold the vehicle on a grade; use the service brakes.
- Do not use the throttle to stop roll back on an incline after Hill Start Aid disengages; use the service brakes, and then relaunch.

- Do not continually start and stop, especially when loaded; use a lower gear or Creep Mode.

18.03.06 Creep Mode

Creep Mode, General Description

The creep mode function allows the vehicle to maintain a constant speed at engine idle without the driver holding the throttle pedal position. This mode is useful for very low-speed maneuvering and applications where steady vehicle speed is required. The vehicle speed is determined by the selected gear ratio operating at governed low engine idle speed. Any available gear may be selected, though the transmission will downshift or exit creep mode to prevent stalling if the engine lugs due to load conditions.

By default, creep mode can be activated while in manual mode or low. Eaton's ServiceRanger diagnostic software can be used to enable creep mode in automatic mode and/or reverse.

Engaging Creep Mode

To engage Creep Mode:

1. Select low, manual, or automatic mode, and the desired gear (while stopped or moving).
2. Apply the throttle pedal to accelerate the vehicle until the clutch is closed (engaged).
3. Release the throttle pedal. The vehicle will continue moving at governed low engine idle speed.

Exiting Creep Mode

To exit creep mode, apply the throttle pedal to accelerate temporarily, or select a higher gear in manual mode. (Creep mode can be resumed in the selected gear by releasing the throttle pedal.)

NOTE: The transmission will exit creep mode if the engine lugs 150 rpm below the governed low engine idle speed. In this case, a lower gear should be selected if available.

18.03.07 Hill Start Aid

Eaton transmissions are equipped with a Hill Start Aid (HSA) feature to prevent the vehicle from rolling while on grades steeper than 3% and allow for a controlled launch. A grade sensor is used to determine when to engage the feature. HSA is 'on' by default. It can be turned off by pressing and releasing the override switch on the dash (see [5.01 Ignition Switch](#)). HSA will turn back on after the first successful launch. When the vehicle is stopped on a grade greater than 3% and in a forward mode or reverse, depress the service brakes then release them. The vehicle will begin to move after 3 seconds, and the clutch will perform partial engagements to slow the vehicle motion. Either step on the brake or apply the throttle to continue negotiating the grade.

18.03.08 Shifting the Shuttle

Shuttle shifting from reverse to any forward mode is only allowed if the vehicle speed is approximately zero.

18.03.09 Auto Start Gear Selection and Override

The transmission uses various inputs to automatically select the best start gear in drive and manual. This selection can be changed using the shift control; however, if the selection requested could cause damage or engine lugging, the request will be denied and a tone will sound.

18.03.10 Shifting the Skip

When appropriate, the transmission may skip shift in drive. When prevailing conditions like load and grade allow, skip shifts can be performed in manual mode using the SmartShift control.

18.03.11 Automatic Traction Control

An Eaton automated transmission system requires the Automatic Traction Control (ATC) option to be enabled when driving in soft soil/sand to prevent wheel slippage and shifting issues.

With the ATC enabled, the system will engage the brakes on the wheel or side that the wheel slip is occurring to help the vehicle gain traction. The point at which the traction control will actuate the braking system increases with throttle: low throttle allows the system to brake the wheels earlier; heavy/full throttle raises the point of the acceptable wheel slip.

Adhere to the following points when driving with ATC enabled:

- If using Automatic mode in soft soil and/or sand, maintain the engine speed between 1000 and 1300 rpm to prevent unnecessary upshifting.
- If using Manual mode in soft soil and/or sand, do not attempt an upshift and try to maintain the current gear.
- If the vehicle comes to a stop in the sand it may be necessary to back up prior to attempting forward movement.

To disable the ATC, depress the ATC switch (see [5.01 Ignition Switch](#)). This mode allows for the drive axle wheels to spin.

18.03.12 Load-Based Shifting

An Eaton automated transmission system is adaptive and will change the shift points based on grade, engine RPM, throttle position, and vehicle load. After changing loads or powering up, the system needs to relearn these inputs for the first few shifts to make the proper adjustments.

18.03.13 Coasting

When coasting to a stop on level terrain, the transmission system may not downshift into the lower gears. It will select a gear after the throttle is applied.

18.03.14 Transmission Low Air Warning

**CAUTION:**

If the yellow 'Caution: Transmission Air Supply Low' popup appears while the vehicle is in operation, slow down, safely pull the vehicle off the road, then correct the problem.

Pneumatic controls are used to shift the transmission. If there is inadequate air pressure, a yellow caution pop-up will appear and the quality of gear shifts may be degraded. See Fig. 359, [Low Transmission Air Pressure Pop-up](#). Wait for air pressure to build before operating the vehicle.

**CAUTION:**

If the red 'Warning: Transmission Will Not Shift' popup appears while the vehicle is in operation, choose the safest location available to pull the vehicle off the road. Prepare for the vehicle to be immobile if the problem cannot be resolved.

If a severe loss of air pressure occurs, a red warning pop-up will appear and the transmission will not shift. See Fig. 360, [No Transmission Air Pressure Pop-up](#).

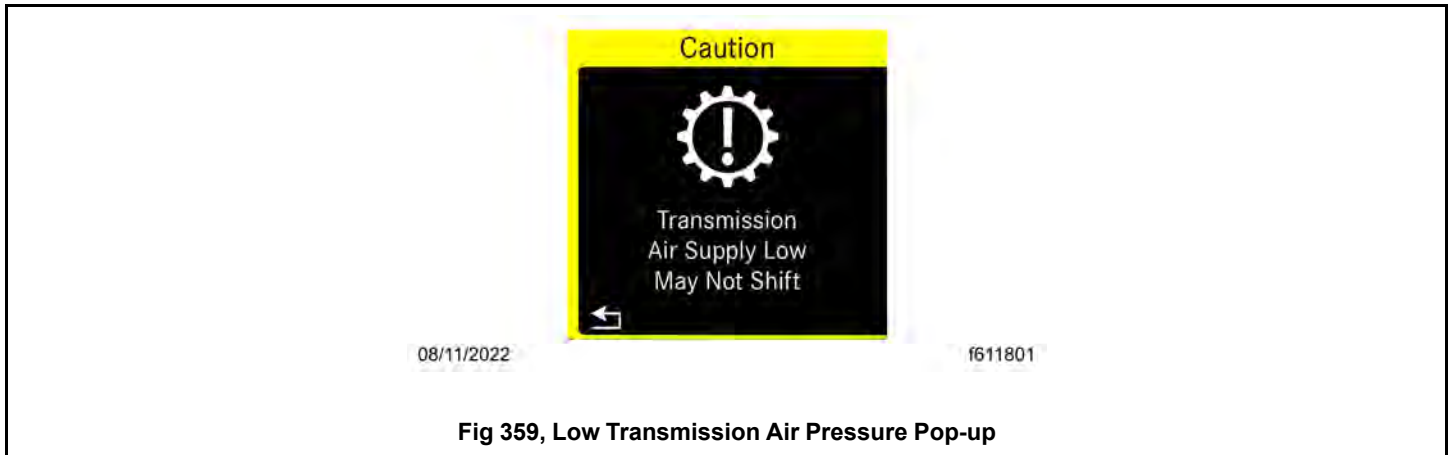

18.03.15 Transmission Prognostics

The Eaton Ultrashift clutch requires the application of grease for maintenance.

The Eaton transmission prognostics display can be found by navigating to the maintenance screens in the driver display. The screen will state if the Grease Interval is OK or if grease needs to be added. See Fig. 361, [Eaton Transmission Prognostics](#).



Fig 361, Eaton Transmission Prognostics

If the system status cannot be read, the message 'SNA' displays.

18.04 Allison Automatic Transmissions

18.04.01 General Information, Allison Transmissions

Refer to the Allison website for additional information: see www.allisontransmission.com.

Allison transmissions have electronic shift controls that can be programmed to allow the use of different numbers of geared speeds. For instance, the transmission can be programmed to operate as a 4-speed, 5-speed, or 6-speed unit in the 'primary' shift mode. If needed, a 'secondary' shift mode can be programmed to provide another shift configuration to optimize vehicle use under different operating conditions. To activate a secondary shift mode, or other special functions programmed into the electronic control unit (ECU), briefly depress the mode switch on the multi-function stalk switch control; see Fig. 362, [Automated/Automatic Transmission Shift Control](#), item 3.

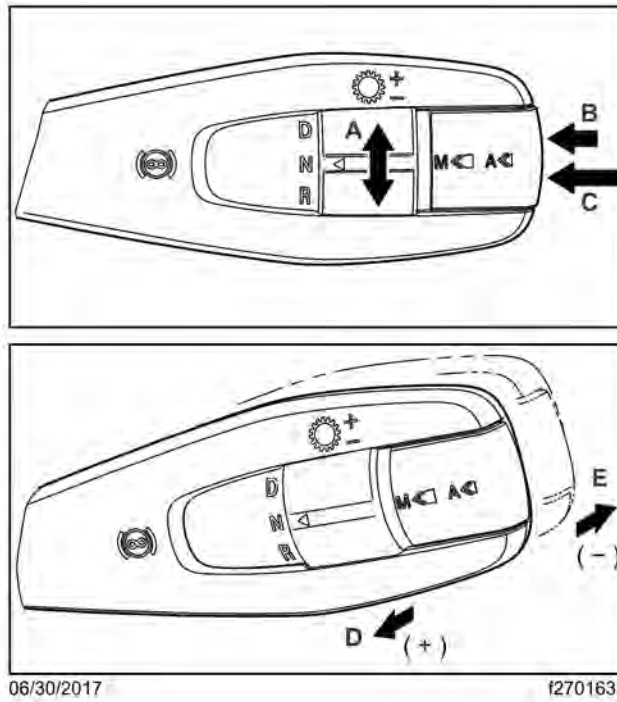

06/30/2017

f270163b

NOTE: See Table for a description of control functionality.

- A. Rotate for drive (D), neutral (N), or reverse (R).
- B. Short press for automatic mode or switch between available modes.
- C. Long press for manual mode.
- D. Pull for upshift (+) request.
- E. Push for downshift (-) request.

Fig 362, Automated/Automatic Transmission Shift Control

These transmissions use the multi-function stalk switch to select mode, direction, neutral, low, and to preselect lower ranges. The current gear, highest available gear, and mode are shown in the driver display; see Fig. 363, [Allison Gear Display in Automatic Mode](#). Forward shifts can be made either automatically or by using Manual mode.



11/07/2017

f611480

- 1. Current Gear
- 2. Highest Gear Available
- 3. Mode

Fig 363, Allison Gear Display in Automatic Mode

18.04.02 Operation Tips, Allison Transmissions

Refer to the Allison website for additional information: see www.allisontransmission.com.

**WARNING:**

Never shift from neutral (N) to drive (D) or reverse (R) at engine speeds above idle. The vehicle will lurch forward or backward, which could cause property damage and personal injury.

**NOTICE:**

The engine should never be operated for more than thirty seconds at full throttle with the transmission in gear and the output stalled. Prolonged operation of this type will overheat the transmission fluid and will result in severe damage to the transmission.

**NOTICE:**

Do not allow the vehicle to coast in neutral. This can result in severe transmission damage. Also, no engine braking is available.

The following tips highlight important operation principles.

- Use reverse (R) to back the vehicle. Completely stop the vehicle before shifting from a forward gear to reverse, or from reverse to forward.
- Select drive (D) for all normal driving conditions. The vehicle will start out in 1st gear (unless the transmission is programmed with 2nd gear start), and as speed increases, the transmission will upshift through each gear automatically. As the vehicle slows down, the transmission will downshift to the correct gear automatically.
- The pressure of your foot on the accelerator pedal influences the automatic shifting. When the pedal is fully depressed, the transmission will automatically upshift at higher engine speeds. A partially-depressed position of the pedal will cause the upshifts to occur at a lower engine speed.
- Occasionally the road, load, or traffic conditions make it desirable to restrict the automatic shifting to a lower range. The lower the gear range, the greater the engine braking power. When in Manual mode, push or pull on the multifunction stalk switch to reach the desired gear. In the lower gear ranges, the transmission will not upshift above the highest gear selected unless the hold override upshift speed is exceeded.
- Use neutral (N) and apply the parking brake when the vehicle is parked with the engine running.

18.04.03 Automatic Mode (A)

Refer to the Allison website for additional information: see www.allisontransmission.com.

In automatic drive mode, upshifts and downshifts are made by the transmission without driver intervention.

Automatic mode is the default start mode. If in manual mode, a short push on the shift control mode switch activates the automatic mode (A). Rotate the D/N/R switch to Drive (D), and press down on the throttle pedal. The transmission will shift automatically.

NOTE: If attempting to select a non-neutral mode without applying the service brakes, the transmission will not shift into gear. To shift into gear, select neutral (N), apply the service brakes, and select the desired mode again.

In drive (D), the start gear is automatically selected. The transmission automatically performs upshifts and downshifts.

18.04.04 Manual Mode (M)

Refer to the Allison website for additional information: see www.allisontransmission.com.

In manual mode, the driver selects the maximum allowed range. This may be helpful when traversing a work site, railroad tracks, or steep grades, for example.

When in automatic mode and with the D/N/R switch set to drive (D), a long push on the shift control mode switch activates the manual mode (M). To increase selected range, pull the lever up (towards you); to decrease the selected range, push the lever down (away from you). The transmission will not upshift above the selected range unless the hold override upshift speed is exceeded.

See Fig. 364, [Allison Gear Display in Manual Mode](#) for an example of the driver display with the transmission in manual mode.

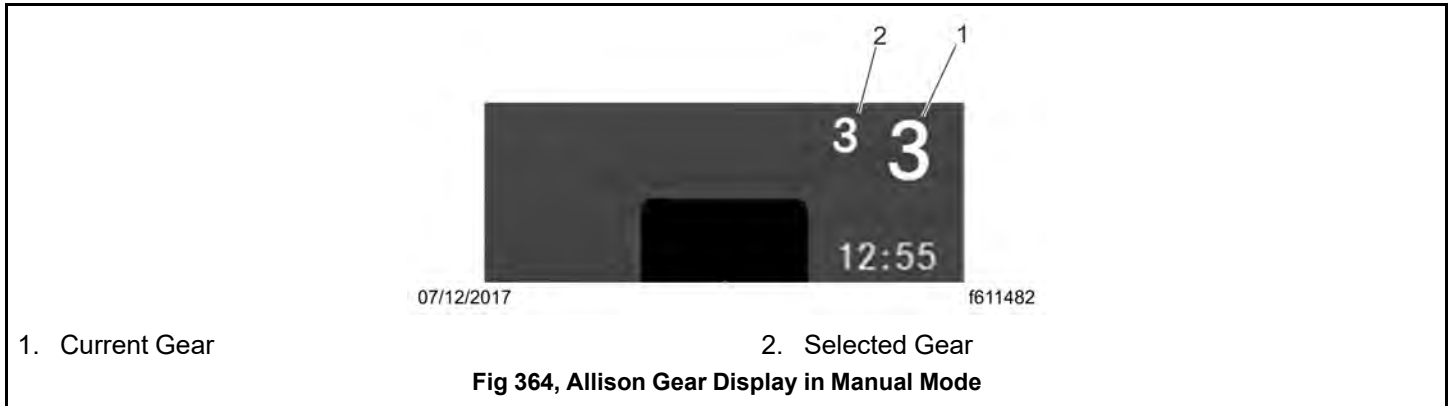

NOTE: The transmission may deny a downshift if the engine speed would fall outside of the acceptable range.

NOTE: If attempting to select a non-Neutral mode without applying the service brakes, the transmission will not shift into gear. To shift into gear, select Neutral (N), apply the service brakes, and select the desired mode again.

18.04.05 Low (L)

Refer to the Allison website for additional information: see www.allisontransmission.com.

Use low when wanting to maximize engine braking and minimize the use of the brake pedal—for example, when driving down long grades or when coming to a stop. To select low, push down on the multi-function stalk switch, and hold in the down-shift position for half a second or more. The lowest available start gear will be selected (the starting gear cannot be changed in low).

If low is selected while moving, the transmission will not upshift (unless the system initiates a low override). The system will downshift at the earliest opportunity to provide maximum engine braking.

In the driver display, the low gear is shown as '1.' See Fig. 365, [Allison Gear Display in Low Gear](#).

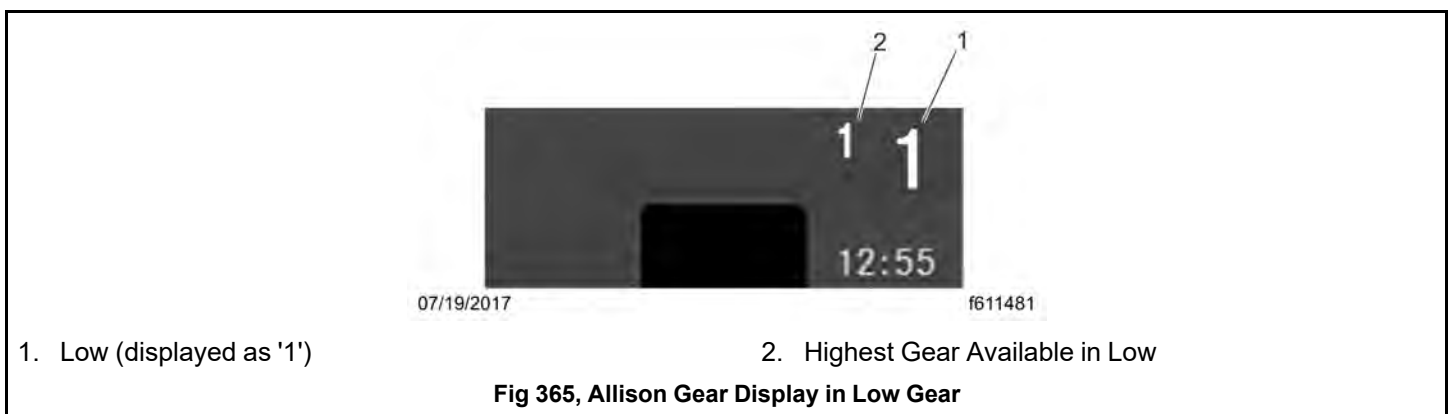

NOTE: If attempting to select a non-neutral mode without applying the service brakes, the transmission will not shift into gear. To shift into gear, select neutral, apply the service brakes, and select the desired mode again.

18.04.06 Transmission Prognostics

Refer to the Allison website for additional information: see www.allisontransmission.com.

The Allison transmission prognostics display can be found by navigating to the maintenance screens in the driver display. The prognostics screen displays information on the transmission health status (oil filter status, oil level, and oil life). See Fig. 366, [Allison Transmission Prognostics](#). If transmission health falls below acceptable limits, a message will be shown on the driver display.

NOTE: For a valid oil level measurement, the vehicle must be stopped on a level surface with the transmission in neutral (N).

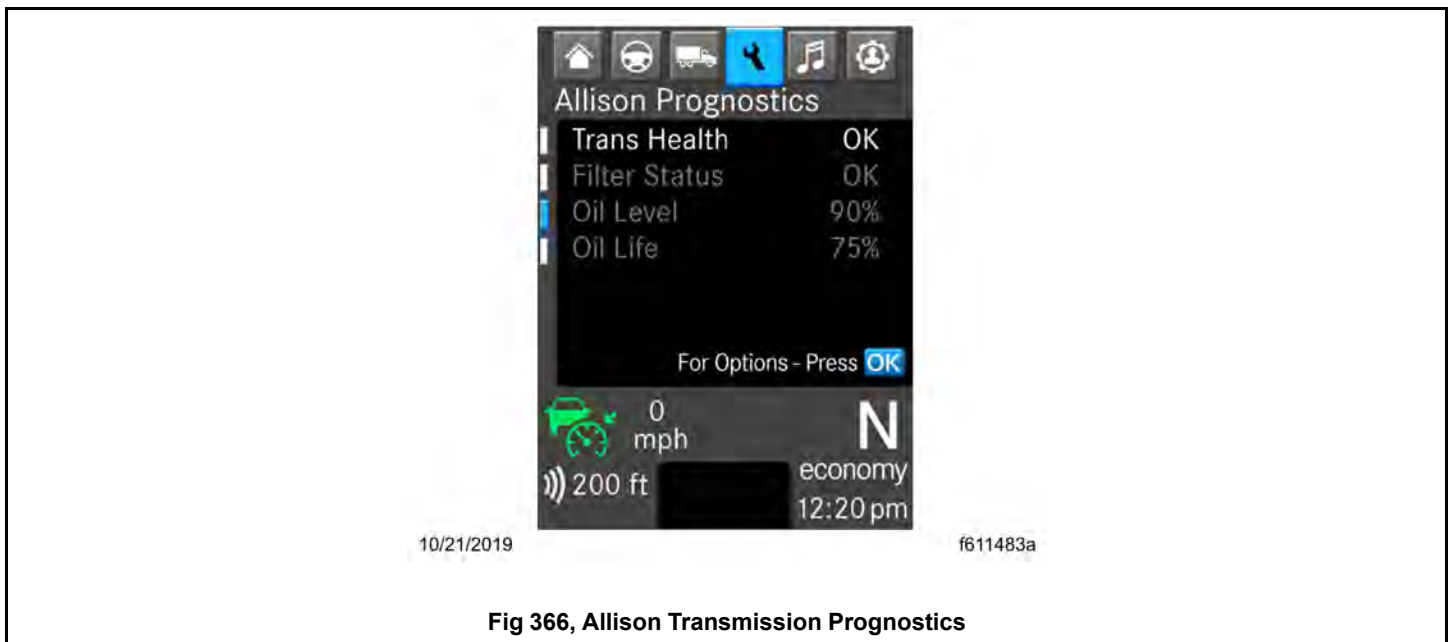

Fig 366, Allison Transmission Prognostics

18.05 Hold Function

The hold function eases the strain of driving in stop-and-go traffic by allowing the driver to 'hold' the brake without constantly applying pressure to the brake pedal. The hold function is an extension of Hill Start Aid (HSA).

To activate the hold function, bring the vehicle to a complete stop, then press the brake pedal further toward the floor. The HOLD telltale, shown in Fig. 367, [Brake Hold Active Telltale](#) illuminates on the driver display to indicate the function is active and the vehicle's brake lights come on. The driver can then take their foot off the brake pedal without the service brakes releasing.

If the brake pedal is pressed down farther, air is added to the chamber, continuing the brake hold.



Fig 367, Brake Hold Active Telltale

To release the brake hold, do one of the following:

- Press the accelerator pedal.
- Engage the park brake.
- Pressing the brake pedal to full stroke and immediately release the brake pedal.

The hold function is deactivated when the HSA OFF switch is pressed to disable HSA.

The hold function is deactivated when the HSA OFF switch is pressed to disable HSA.

- The anti-lock braking system was active in bringing the vehicle to a stop;
- The anti-lock braking system is in a fault state;
- The vehicle is in reverse gear.

If the hold function is active for four minutes, the window shown in Fig. 368, [Engage Park Brake Message - ICC5](#) appears on the ICU, warning the driver to engage the park brake. An audible alarm activates at the same time and repeats every minute until the park brake is set.

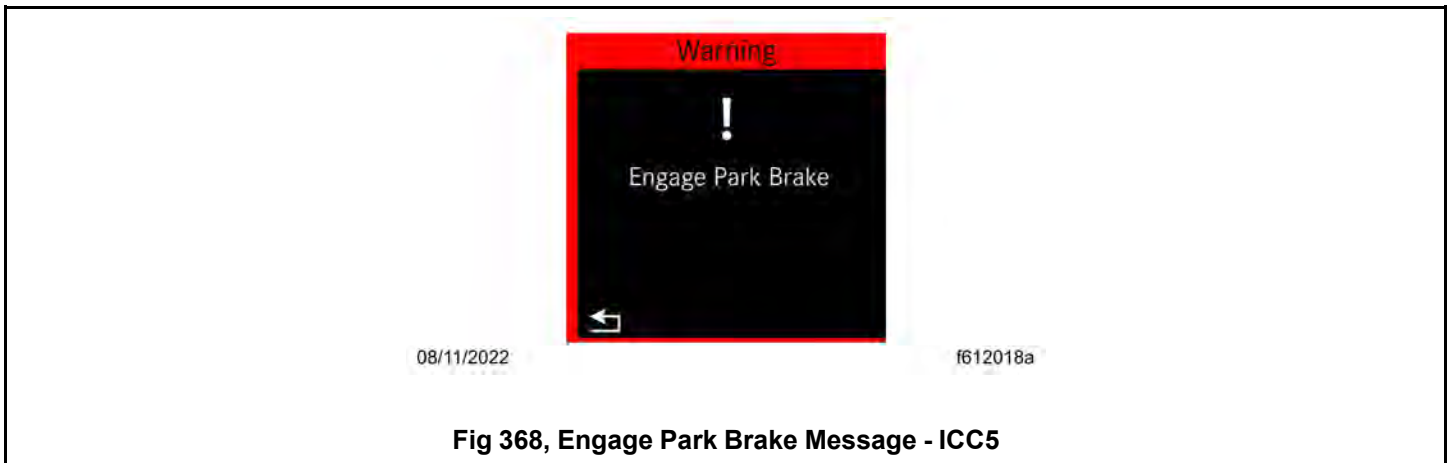

Fig 368, Engage Park Brake Message - ICC5

The same warnings are triggered if the hold function is active and:

- The ignition is turned off without the park brake being set;
- The brakes are not strong enough to hold the vehicle in place and it starts rolling.

If a door is opened without the park brake being set when the hold function is active, the horn sounds and a visual warning activates on the driver display. If the seat occupancy sensor registers an empty seat under the same conditions, the same warnings are triggered. Warnings cease when the condition that triggered the warning is corrected.

| | |
|--|-----|
| 19.01 Eaton® Fuller® Manual Transmissions | 436 |
| 19.01.01 General Information, Eaton Fuller Manual Transmissions..... | 436 |
| 19.01.02 Transmission Operation Tips..... | 436 |
| 19.02 Clutch..... | 436 |
| 19.02.01 General Information, Clutch | 436 |
| 19.02.02 Operation of the Clutch..... | 437 |
| 19.02.03 Adjustment of the Clutch..... | 438 |

19. Manual Transmissions and Clutch

19.01 Eaton® Fuller® Manual Transmissions

19.01.01 General Information, Eaton Fuller Manual Transmissions

This vehicle may be equipped with an Eaton 10-, 13-, or 18-speed manual transmission. Vehicles with Eaton manual transmissions have clutch brakes and a hydraulic clutch actuation system.

The transmission shift pattern is printed on a decal attached to the driver-side sun visor or to the dash below the center dash panel. The shift pattern may also be printed on the shift knob.

NOTE: For additional information, refer to the Eaton website, see www.roadranger.com.

19.01.02 Transmission Operation Tips

Follow these important operation principles:

- For all conditions, use the highest gear that is still low enough to start the vehicle moving with the engine at or near idle speed, and without slipping the clutch excessively.
When operating on-highway with no load or under ideal conditions, use 1st gear to start the vehicle moving forward.
When operating off-road or under adverse conditions, use LOW gear to start the vehicle moving forward.
- Use the clutch brake to stop gear rotation when shifting into LOW or reverse while the vehicle is stationary. The clutch brake is actuated by depressing the clutch pedal all the way to the floor.
- Partially disengage the clutch to break engine torque during normal gear shifts.
- Double-clutch between all upshifts and downshifts that require movement of the shift knob. Splitting of gears does not require movement of the shift knob.
- Never push the range-preselection lever down into low range while operating in high range, except when downshifting from 5th gear to 4th gear.
- Do not shift from high range to low range at high vehicle speeds.
- Never make a range shift or a splitter shift while the vehicle is in reverse.
- Never move the range-preselection lever with the transmission in neutral while the vehicle is moving.
- Skip ratios while shifting **only** when operating conditions permit, depending on the load, grade, and road speed.
- Never coast with the transmission in neutral.

19.02 Clutch

19.02.01 General Information, Clutch

The hydraulic clutch control system consists of a pedal unit and a secondary cylinder connected by a hydraulic hose. The components of the system have been specially designed to use DOT 4 brake fluid. The hydraulic system is self-adjusting.

Typical operation will not break down the clutch friction surfaces. Heat and wear are almost nonexistent when a clutch is fully engaged. However, during the moment of engagement, when the clutch is picking up the load, considerable heat is generated. If a clutch slips excessively, high temperatures develop quickly between the flywheel, driven discs, and pressure plates. An improperly adjusted or slipping clutch can generate temperatures high enough to cause the friction-facing material to char and burn, destroying the clutch.

To ensure long service life of the clutch, start in the right gear and be alert to clutch malfunctions.

19.02.02 Operation of the Clutch

Clutch Break-In

With a new or newly installed clutch, the clutch may slip for a short time while the friction surfaces break-in. However, allowing the clutch to slip for more than two seconds can severely damage the clutch disc, pressure plate, and the flywheel.

During initial operation of a new vehicle or a vehicle with a new clutch, check for clutch slippage during acceleration. If the clutch slips, decelerate until the clutch does not slip. Allow the clutch to cool 15 to 30 seconds, and then gradually accelerate again. If the clutch continues to slip, repeat the procedure. If necessary, repeat the procedure up to five times. If the clutch slips after five attempts, stop the vehicle. Allow the clutch to cool for at least one hour. Notify your Freightliner dealer of the problem.

**NOTICE:**

Do not allow sustained slippage of the clutch; this could severely damage the clutch disc, pressure plate, or flywheel. Damage caused by clutch slippage due to improper break-in is not warrantable.

Using the Clutch Brake

The clutch brake is applied by depressing the clutch pedal past the fully released clutch position, almost to the floor plate. The last part of the clutch pedal travel will compress the clutch brake plates together, stopping the transmission input shaft. The purpose of the clutch brake is to stop the transmission gears from rotating in order to quickly engage a transmission gear after idling in neutral.

**NOTICE:**

Never apply the clutch brake when the vehicle is moving. If the clutch brake is applied when the vehicle is moving, the clutch brake will try to stop or decelerate the vehicle, causing rapid wear of the clutch brake friction discs. Considerable heat will be generated, causing damage to the release bearings and the transmission front bearings.

Holding the Vehicle on an Incline

Always use the vehicle service brakes to prevent the vehicle from rolling backwards while stopped on a hill. Slipping the clutch on a hill to maintain the vehicle position will quickly damage the clutch assembly.

Coasting

Coasting with the clutch pedal depressed and the transmission in a low gear can cause high driven disc speed. The clutch speed can be much higher under these conditions than when the engine is driving the clutch. This condition creates a hazardous situation due to the lack of vehicle control and due to the high clutch disc speed. Engaging the clutch under these conditions can cause component damage because of the shock loads to the clutch and drivetrain.

**WARNING:**

Always shift into the gear that is correct for the traveling speed of the vehicle and engage the clutch. Coasting with the clutch disengaged can prevent engagement of the correct transmission gear which can cause loss of vehicle control, possibly resulting in personal injury or property damage.

High clutch disc speeds while coasting can also cause the clutch facing to be thrown off the disc. Flying debris from the clutch can cause injury to persons in the cab.

19.02.03 Adjustment of the Clutch

Eaton Fuller Solo clutches are adjustment-free. As the clutch wears, its wear-adjusting technology monitors clutch components and makes any necessary adjustments. The wear adjusting technology comes from two sliding cams, which rotate to maintain the proper adjustment. Atop the upper cam, a wear indicating tab mirrors the cam's movement, letting you know when it's time to replace the clutch.

| | |
|---|-----|
| 20.01 Interaxle Lock, Tandem Axles | 440 |
| 20.01.01 General Description, Interaxle Lock and Tandem Axles | 440 |
| 20.01.02 Interaxle Lock Switch | 440 |
| 20.01.03 Operation of Interaxle Lock | 441 |
| 20.02 Driver-Controlled Differential Lock (DCDL) | 442 |
| 20.02.01 General Description, Driver-Controlled Differential Lock (DCDL)..... | 442 |
| 20.02.02 Differential Lock Switch | 443 |
| 20.02.03 DCDL Operation | 444 |
| 20.02.04 Single Drive Axles with Traction Equalizer..... | 445 |

20. Drive Axles

20.01 Interaxle Lock, Tandem Axles

20.01.01 General Description, Interaxle Lock and Tandem Axles

The interaxle lock (axle lock, interaxle differential lockout) feature causes the drive axle shafts to rotate together, and is recommended for use under adverse road conditions where greater traction is needed.

When engaged, the interaxle lock essentially makes the driveshaft a solid connection between the drive axles. Power entering the forward axle is transmitted straight through to the rearmost axle(s). Driveline torque is now delivered equally and the drive axles, and wheels, turn together at the same speed. The interaxle lock increases drivetrain and tire wear and should be used only when improved traction is required.

A status screen showing engaged locks is found in the vehicle operations menus on the driver display. See Fig. 369, [Interaxle and Differential Locks Status Screen](#).

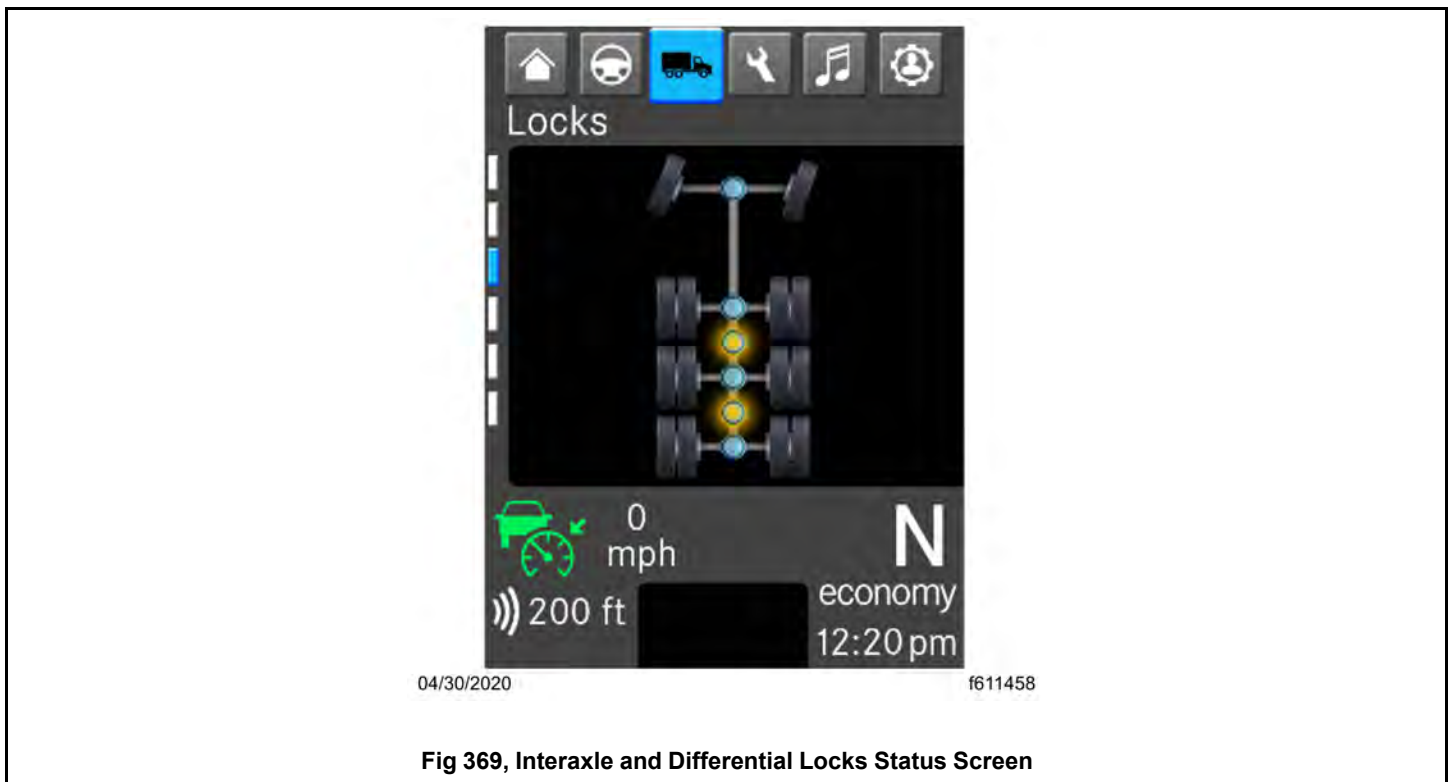
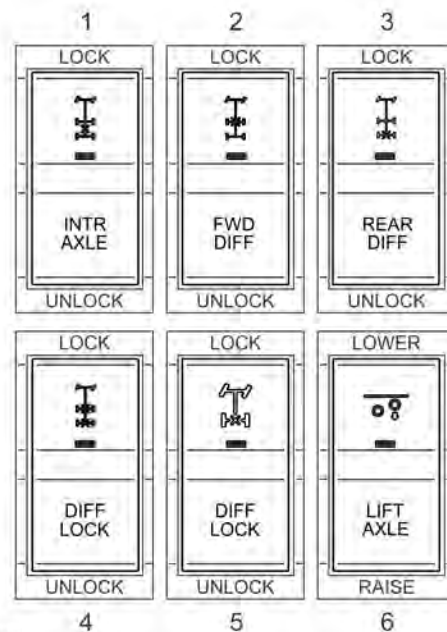

Fig 369, Interaxle and Differential Locks Status Screen

20.01.02 Interaxle Lock Switch

The interaxle lock switch, shown in Fig.370, [Axle Switches](#), allows the driver to lock the drive axles together. If the vehicle is equipped with Detroit axles, the switch illumination indicates the lock is engaged.



09/15/2016

f611344

- | | |
|--|----------------------------------|
| 1. Interaxle Lock Switch | 4. Differential Lock Switch, 6X4 |
| 2. Forward Drive Axle Differential Lock Switch | 5. Differential Lock Switch, 4X2 |
| 3. Rear Drive Axle Differential Lock Switch | 6. Lift Axle Switch |

Fig 370, Axle Switches

20.01.03 Operation of Interaxle Lock

**NOTICE:**

The interaxle lock should not be engaged on a vehicle with obviously spinning wheels. Engagement at high speed or power can damage the axle(s).

NOTE: If the interaxle lock is engaged when the engine is turned off, the interaxle lock will disengage.

Do not wait until traction is lost and the tires are spinning before engaging the interaxle lock.

1. With the engine running, press the upper half of the interaxle lock switch to engage the interaxle lock. If the vehicle is moving, briefly let up on the accelerator until the interaxle lock engages.

If the vehicle is equipped with Detroit axles, the illumination of the switch indicates the lock is engaged. Depending on the vehicle configuration, a buzzer may also sound.

**NOTICE:**

Do not operate the vehicle continuously with the interaxle locked during extended good road conditions. To do so could result in damage to the axle gearing and excessive driveline and tire wear.

2. Proceed over poor road conditions with caution.
3. After leaving poor road conditions, press the lower half of the interaxle lock switch to disengage the interaxle lock. If the vehicle is moving, briefly let up on the accelerator to allow the interaxle lock to disengage.

If the vehicle is equipped with Detroit axles, the deactivation of the indicator light on the switch indicates disengagement.
4. Resume driving at normal speed.

20.02 Driver-Controlled Differential Lock (DCDL)

20.02.01 General Description, Driver-Controlled Differential Lock (DCDL)

The driver-controlled differential lock (DCDL) feature (side-to-side wheel lock, traction control, or traction equalizer) is available on vehicles with single- or tandem-drive axles.

The DCDL provides maximum traction for slippery conditions by forcing the wheels on each drive axle governed by the switch to rotate together. When the DCDL is engaged, the clutch collar completely locks the differential case, gearing, and axle shafts together, maximizing the traction of both wheels. Use the DCDL if the interaxle lock does not provide sufficient traction.

A status screen showing engaged locks is found in the vehicle operations menus on the driver display. See Fig. 371, [Interaxle and Differential Locks Status Screen](#).

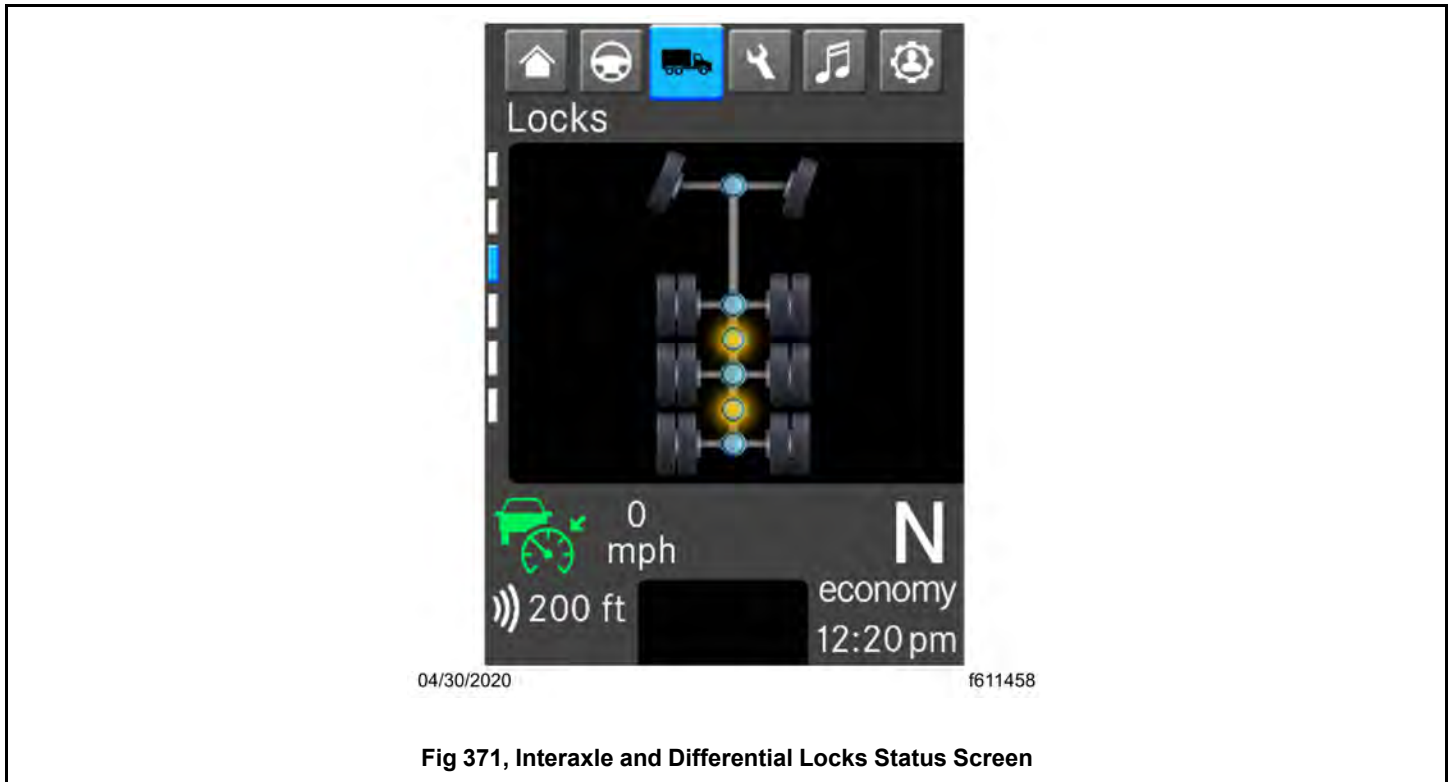

20.02.02 Differential Lock Switch

Each differential lock is controlled by a switch on the dash. See Fig.372,[Axle Switches](#).

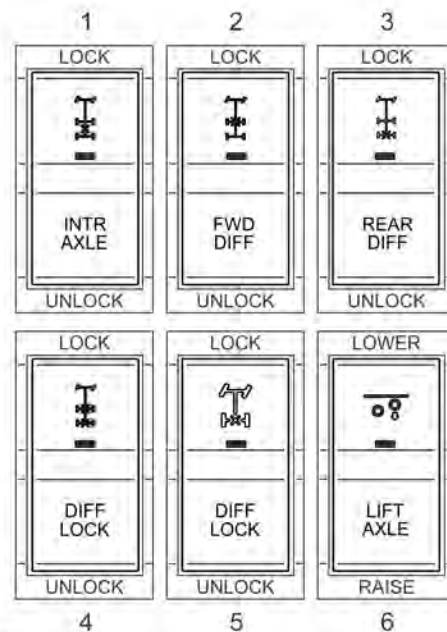

- | | |
|--|----------------------------------|
| 1. Interaxle Lock Switch | 4. Differential Lock Switch, 6X4 |
| 2. Forward Drive Axle Differential Lock Switch | 5. Differential Lock Switch, 4X2 |
| 3. Rear Drive Axle Differential Lock Switch | 6. Lift Axle Switch |

Fig 372, Axle Switches

20.02.03 DCDL Operation



NOTICE:

Engage the DCDL only when the vehicle is stopped or moving at less than 5 mph (8 km/h). Engaging the DCDL at speeds above 5 mph (8 km/h) can cause internal axle damage.

NOTE: On some vehicles, the differential lock system is connected through the low speed range of the transmission. If this system is used, the transmission must be in the low speed range for the wheels to fully lock. In addition, shifting out of low speed range will also disengage the differential lock.

NOTE: If the DCDL is engaged when the engine is shut down, the DCDL will disengage.

1. With the engine running, press the upper half of the differential lock switch to engage the DCDL.
2. If the vehicle is moving, briefly let up on the accelerator to relieve torque on the gearing, allowing the differential to fully lock. An indicator light on the differential lock switch illuminates when the lock is engaged. Depending on the vehicle configuration, a buzzer may also sound.

**WARNING:**

Be especially careful when driving under slippery conditions with the differential locked. Though forward traction is improved, the vehicle can still slip sideways, causing possible loss of vehicle control, personal injury, and property damage.

3. Drive cautiously and do not exceed 25 mph (40 km/h). When the differential is fully locked, the turning radius will increase because the vehicle understeers. See Fig.373, [Turning Radii](#).

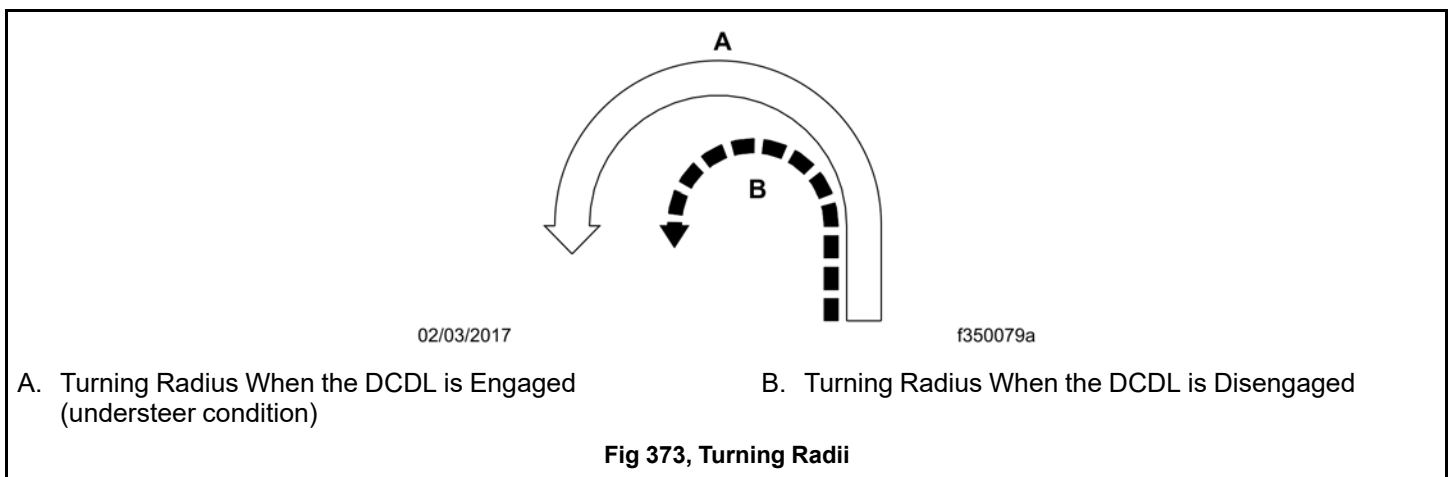

4. Press the lower half of the differential lock switch to disengage the DCDL after leaving poor road conditions.
5. If the vehicle is moving, briefly let up on the accelerator to allow the wheels to fully unlock, then resume driving at normal speed.

20.02.04 Single Drive Axles with Traction Equalizer

Some single drive axles are equipped with a traction equalizer that is a load-sensing, self-actuating feature. A traction equalizer provides normal differential action where traction is good. When one wheel begins to spin faster than the other, clutch plates in the differential housing automatically engage, delivering power to both wheels. There is no operator control with this feature.

**NOTICE:**

Tire sizes on both rear wheels should be the same on axles equipped with a traction equalizer. If not, excessive wear may occur in the traction equalizer.

| | |
|---|-----|
| 21.01 Fifth Wheels, General Information..... | 448 |
| 21.01.01 Fifth Wheel Lubrication | 448 |
| 21.02 Fifth Wheel Coupling | 448 |
| 21.02.01 Fontaine and Holland Fifth Wheels Coupling | 448 |
| 21.02.02 Jost Fifth Wheel Coupling | 452 |
| 21.03 Fifth Wheel Uncoupling | 456 |
| 21.03.01 Manual Uncoupling | 456 |
| 21.03.02 Air-Actuated Uncoupling | 458 |
| 21.04 Fifth Wheel Slide | 460 |
| 21.04.01 General Description, Fifth Wheel Slide..... | 460 |
| 21.04.02 Operation of Manual Slide..... | 460 |
| 21.04.03 Operation of the Air Slide | 462 |

21. Fifth Wheels

21.01 Fifth Wheels, General Information

21.01.01 Fifth Wheel Lubrication

**WARNING:**

Do not use any fifth wheel that fails to operate properly. Doing so may cause loss of vehicle control, possibly resulting in severe personal injury or death.

**WARNING:**

A standard fifth wheel plate must be kept lubricated to prevent binding between the tractor and trailer. A binding fifth wheel could cause erratic steering and loss of vehicle control, possibly resulting in personal injury or death.

The standard fifth wheel plate must be kept well lubricated with chassis grease to prevent friction and binding between the tractor fifth wheel plate and the trailer.

For a low-lube fifth wheel plate, inspect the condition of the low-lube pads. There should be no damaged or missing pieces. Slight puckering at the outside edges is normal.

For lubrication instructions, see Group 31 of the maintenance manual.

21.02 Fifth Wheel Coupling

21.02.01 Fontaine and Holland Fifth Wheels Coupling

Fifth wheel coupling is activated with the lock control handle located on either the right side or left side of the fifth wheel. Coupling has successfully occurred when the kingpin has been forced into the jaws and the lock control handle has moved to the locked position.

**NOTICE:**

Some fifth wheels may be mounted on sliding rails. Before attempting to couple a trailer to a sliding fifth wheel, the slide feature must be locked to prevent the top plate from sliding rapidly forward or rearward, causing damage to the fifth wheel or kingpin.

1. Chock the front and rear of the trailer tires to prevent the trailer from moving.
2. Ensure the fifth wheel jaw is fully open and the operating rod is in the unlocked position. See Fig. 374, [Fontaine Locking Mechanism](#) or Fig. 375, [Holland Simplex SE Locking Mechanism](#).

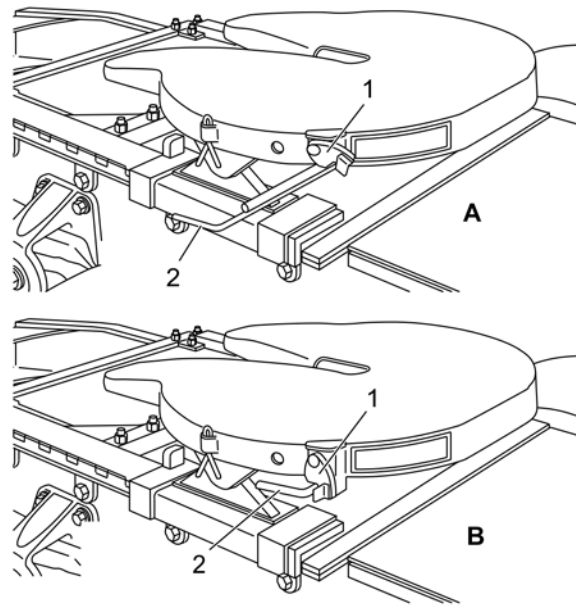

04/06/2017

f310110a

NOTE: Make sure the safety latch is down when the control handle is locked.

- A. Unlocked
- B. Locked

- 1. Safety Latch
- 2. Lock Control Handle

Fig 374, Fontaine Locking Mechanism

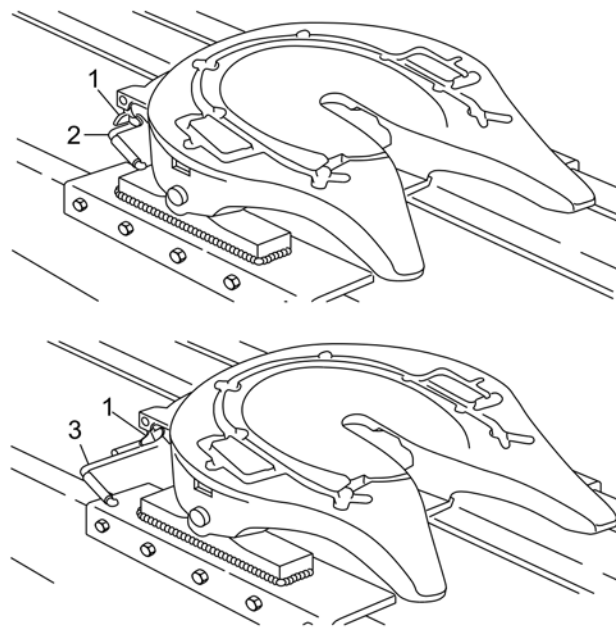

04/19/2017

f310447

- 1. Safety Latch
- 2. Operating Rod (locked)

- 3. Operating Rod (unlocked)

Fig 375, Holland Simplex SE Locking Mechanism

3. Make sure the fifth wheel top plate is tilted so the ramps are as low as possible.
4. Position the tractor so that the center of the fifth wheel is in line with the trailer kingpin. The kingpin should be in a position to enter the throat of the locking mechanism.

**NOTICE:**

Attempting to couple at the wrong height may cause improper coupling, which could result in damage to the fifth wheel or kingpin.

5. Adjust the trailer height if required.

For a standard fifth wheel plate, the trailer should contact the fifth wheel approximately 4 to 8 inches (10 to 20 cm) behind the fifth wheel pivot. See Fig.376, [Trailer Connection Point, Standard Fifth Wheel](#).

For a low-lube fifth wheel plate, the fifth wheel must slide freely under the trailer, and the trailer should contact the fifth wheel at the pivot. See Fig.377, [Trailer Connection Point, Low-Lube Fifth Wheel](#).

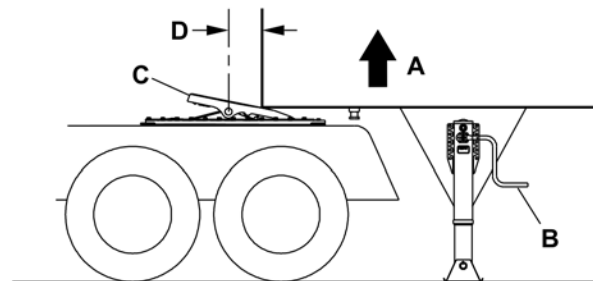

04/28/2017

f311124

A proper connection for a standard fifth wheel trailer is ensured by ALL of the following:

- | | |
|---|--|
| <p>A. The fifth wheel is lifting the trailer.</p> <p>B. The trailer height is adjusted with the crank.</p> <p>C. The ramps are tilted down.</p> | <p>D. The trailer is connected 4 to 8 inches behind the fifth wheel pivot.</p> |
|---|--|

Fig 376, Trailer Connection Point, Standard Fifth Wheel

A proper connection for a standard fifth wheel trailer is ensured by ALL of the following:

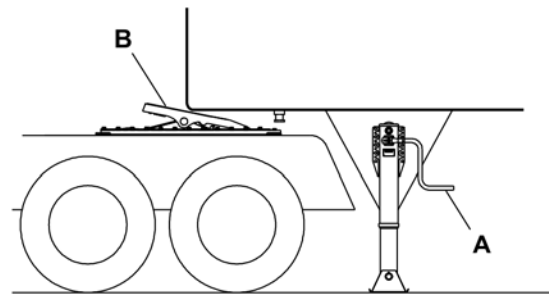

04/28/2017

f311125

A proper connection for a low-lube fifth wheel trailer is ensured by both of the following:

- A. The trailer height is adjusted with the crank. B. The ramps are tilted down.

Fig 377, Trailer Connection Point, Low-Lube Fifth Wheel

A proper connection for a low-lube fifth wheel trailer is ensured by both of the following:

6. With the fifth wheel lock opening aligned with the trailer kingpin, back the tractor slowly toward the trailer. After sliding under the trailer, STOP to prevent from hitting the kingpin too hard, then resume backing slowly until the fifth wheel locks.

On a standard fifth wheel, the fifth wheel must lift the trailer.

On a low-lube fifth wheel, do not lift the trailer as this may damage the fifth wheel plate.

7. Apply the tractor parking brakes.



WARNING:

A visual inspection is required by law. Some improper couplings can pass a pull test. Sound is not reliable. Get out of the cab and look. Incorrect coupling could cause the trailer to disconnect, possibly resulting in serious personal injury or death.

8. Perform a coupling inspection, checking that there is no gap between the bottom of the trailer and the fifth wheel, and that the kingpin is securely locked. See Fig.378, [Coupling Inspection](#).

When lockup has occurred, the fifth wheel control handle moves to the locked position. Make sure that the safety latch is down over the lock control handle to hold the control handle in the locked position. (The safety latch will only rotate down if the operating rod is fully retracted in the locked position.) See Fig.374, [Fontaine Locking Mechanism](#) for Fontaine fifth wheels. See Fig.375, [Holland Simplex SE Locking Mechanism](#) for Holland fifth wheels.

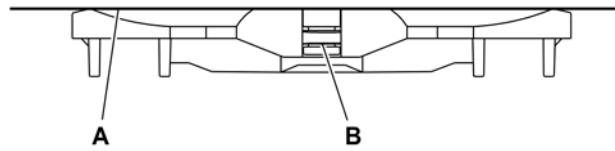

04/28/2017

f311126

A successful inspection of the trailer coupling requires both of the following:

- A. There is no gap between the trailer and fifth wheel. B. The kingpin is securely locked.

Fig 378, Coupling Inspection

A successful inspection of the trailer coupling requires both of the following:

9. Release the tractor parking brakes. Test for kingpin lockup slowly inching the tractor forward, pulling on the trailer against the chocks.
10. After lockup is completed, connect the tractor-to-trailer air system lines and the electrical cable to the trailer. Take care to prevent dirt or foreign material from entering the air system lines.



NOTICE:

Always make sure the connection hanger keeps the trailer air hoses and electrical cables positioned so that they do not rub on anything. Rubbing may wear through hoses or cables, resulting in air leaks, or exposed or broken wires, potentially affecting trailer brake or electrical systems.

11. Charge the air brake system with air, checking that the air connections do not leak.



WARNING:

Incorrect fifth wheel lock adjustment could cause the trailer to disconnect, possibly resulting in serious personal injury or death.

12. With the trailer wheels chocked and the brakes set, check for clearance between the kingpin and the fifth wheel jaws by moving the tractor forward and backward against the locked kingpin. If slack is present, uncouple the trailer and have the fifth wheel inspected and adjusted by a certified technician.

21.02.02 Jost Fifth Wheel Coupling

Fifth wheel coupling is activated with the lock control handle located on either the right side or left side of the fifth wheel. Coupling has successfully occurred when the kingpin has been forced into the jaws and the lock control handle has moved to the locked position.

**NOTICE:**

Some fifth wheels may be mounted on sliding rails. Before attempting to couple a trailer to a sliding fifth wheel, the slide feature must be locked to prevent the top plate from sliding rapidly forward or rearward, causing damage to the fifth wheel or kingpin.

1. Tilt the ramp down.
2. Open the kingpin locks. See Fig.379, [Jost Release Handle Unlocked](#).

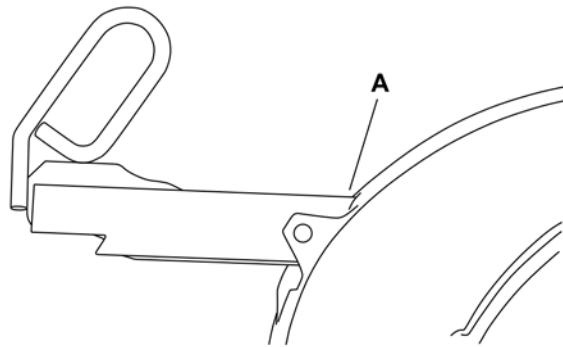

A. When the kingpin locks are opened, they will be held open by the catch mechanism.

Fig 379, Jost Release Handle Unlocked

3. Back the vehicle close to the trailer, centering the kingpin on the fifth wheel.
4. Chock the trailer wheels.
5. Connect the air lines and electrical cable.
6. Ensure that the red trailer air supply valve (trailer brake) is pulled out, and that the trailer parking brakes are set. See [5.01 Ignition Switch](#) in this manual for operation of the dash-mounted brake controls.

**NOTICE:**

Attempting to couple at the wrong height may cause improper coupling, which could result in damage to the fifth wheel or kingpin.

7. Adjust the trailer height (if required).

For a standard fifth wheel plate, the trailer should contact the fifth wheel approximately 4 to 8 inches (10 to 20 cm) behind the pivot. See Fig.380, [Trailer Connection Point, Standard Fifth Wheel](#).

For a low-lube fifth wheel plate, the fifth wheel must slide freely under the trailer, and the trailer should contact the fifth wheel at the pivot. See Fig.381, [Trailer Connection Point, Low-Lube Fifth Wheel](#).

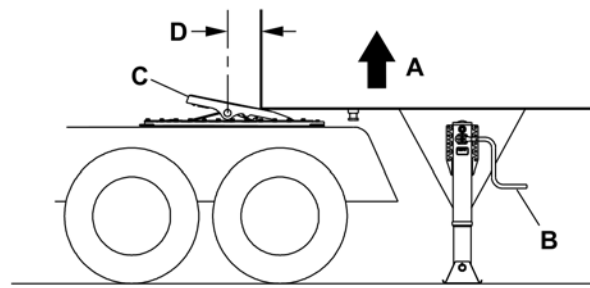

04/28/2017

f311124

A proper connection for a standard fifth wheel trailer is ensured by all of the following:

- A. The fifth wheel is lifting the trailer.
- B. The trailer height is adjusted with the crank.
- C. The ramps are tilted down.
- D. The trailer is connected 4 to 8 inches behind the fifth wheel pivot.

Fig 380, Trailer Connection Point, Standard Fifth Wheel

A proper connection for a standard fifth wheel trailer is ensured by all of the following:

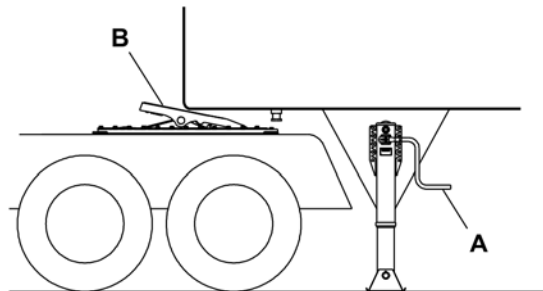

04/28/2017

f311125

A proper connection for a low-lube fifth wheel trailer is ensured by both of the following:

- A. The trailer height is adjusted with the crank.
- B. The ramps are tilted down.

Fig 381, Trailer Connection Point, Low-Lube Fifth Wheel

A proper connection for a low-lube fifth wheel trailer is ensured by both of the following:

- 8. Back the tractor under the trailer.
 - On a standard fifth wheel, the fifth wheel must lift the trailer.
 - On a low-lube fifth wheel, do not lift the trailer as this may damage the fifth wheel plate.
- 9. After sliding under the trailer, STOP to prevent from hitting the kingpin too hard, then resume backing slowly until the fifth wheel locks.

**WARNING:**

A visual inspection is required by law. Some improper couplings can pass a pull test. Sound is not reliable. Get out of the cab and look. Incorrect coupling could cause the trailer to disconnect, possibly resulting in serious personal injury or death.

10. Apply the tractor parking brake, then perform a physical check for positive kingpin lockup, and that there is no gap between the trailer and the fifth wheel. See Fig.382, [Coupling Inspection](#).

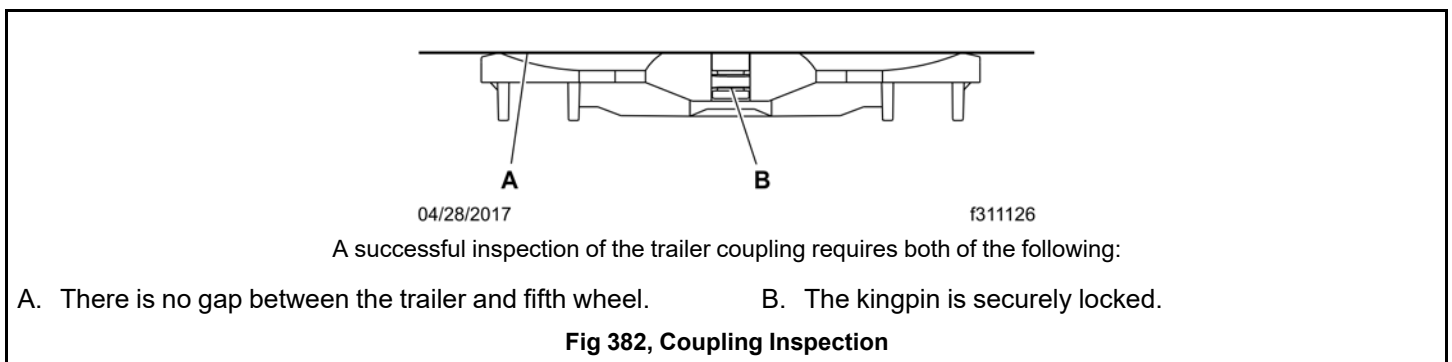

A successful inspection of the trailer coupling requires both of the following:

11. Ensure that the release handle is in the locked position adjacent to the casting. See Fig. 383, [Jost Release Handle Locked](#).

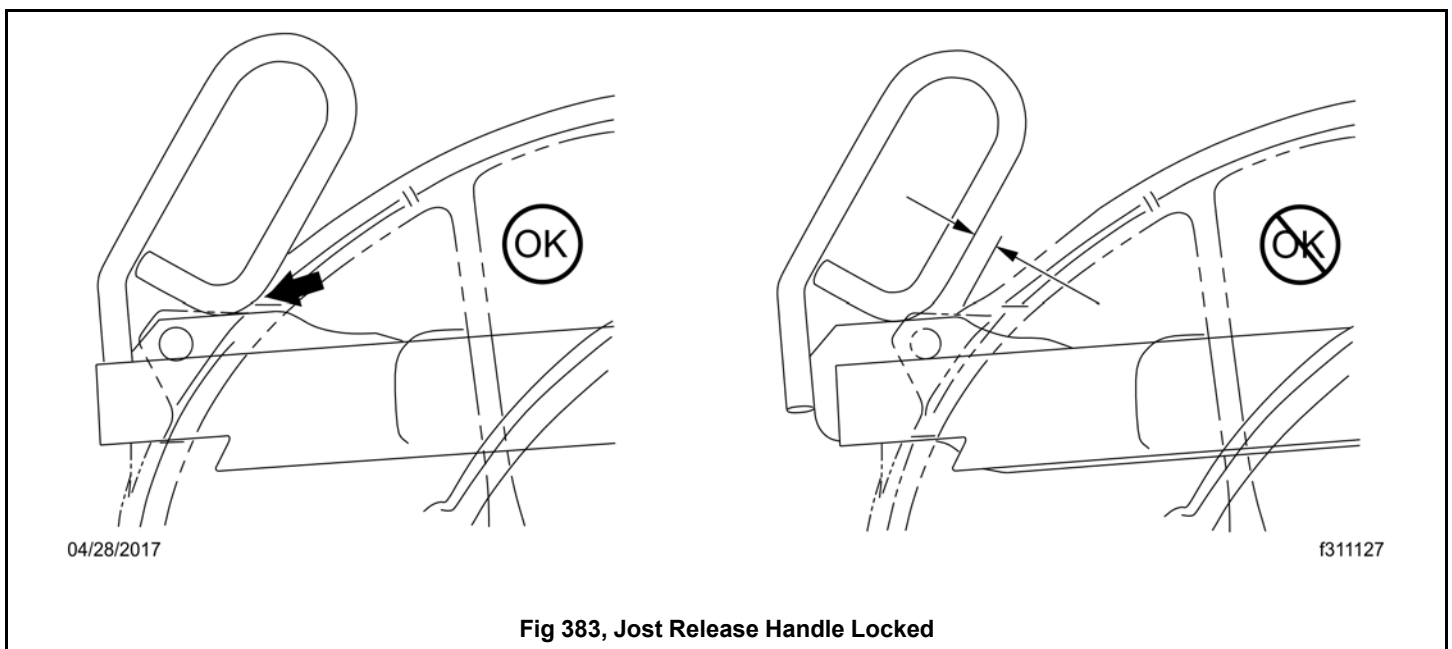

12. Release the tractor parking brakes and test for kingpin lockup by slowly moving the tractor forward, pulling on the trailer against the chocks.

21.03 Fifth Wheel Uncoupling

21.03.01 Manual Uncoupling

1. Apply the tractor and trailer parking brakes.
2. Chock the trailer rear wheels.
3. Lower the trailer landing gear until the weight is removed from the fifth wheel.
4. Disconnect the tractor-to-trailer air system lines and electrical cable. Plug the air lines to prevent dirt or foreign material from entering the lines.
5. Verify that both the yellow parking-brake and red trailer-air-supply knobs are out, the tractor and trailer parking brakes are set, and that the trailer is prepared for uncoupling.
6. Release the kingpin locking mechanism following the instructions for each manufacturer below.
 - 6.a **Fontaine:** Lift the safety latch and pull the lock control handle to the unlocked position. See Fig. 384, [Fontaine Locking Mechanism](#).

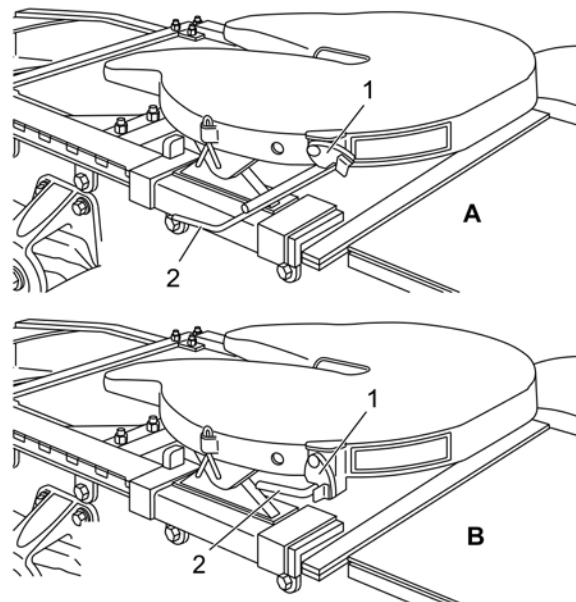

04/06/2017

f310110a

NOTE: Make sure the safety latch is down when the control handle is locked.

- | | |
|---|--|
| <p>A. The Fontaine locking mechanism in the unlocked position.</p> <p>B. The Fontaine locking mechanism in the locked position.</p> | <p>1. Safety Latch</p> <p>2. Lock Control Handle</p> |
|---|--|

Fig 384, Fontaine Locking Mechanism

- 6.b **Holland:** In the locked position the safety indicator swings freely over the operating rod. See Fig. 385, [Holland Kingpin Locking Mechanism](#), View A.

To unlock the mechanism, manually rotate the safety indicator toward the rear of the fifth wheel. See Fig. 385, [Holland Kingpin Locking Mechanism](#), View B.

Pull the operating rod out. When the upper operating rod shoulder is outside the slot, raise the handle and place the shoulder of the upper rod against the plate casting, above the slot. See Fig. 385, [Holland Kingpin Locking Mechanism](#), View C.

The fifth wheel is now in the lockset position and is ready for uncoupling. As the tractor pulls away from the trailer the kingpin forces the jaw to rotate, contacting the lock. Continued rotation of the jaw forces the lock to move outward, and drops the upper rod back into the slot. See Fig. 385, [Holland Kingpin Locking Mechanism](#) View D. The wheel is now ready for coupling.

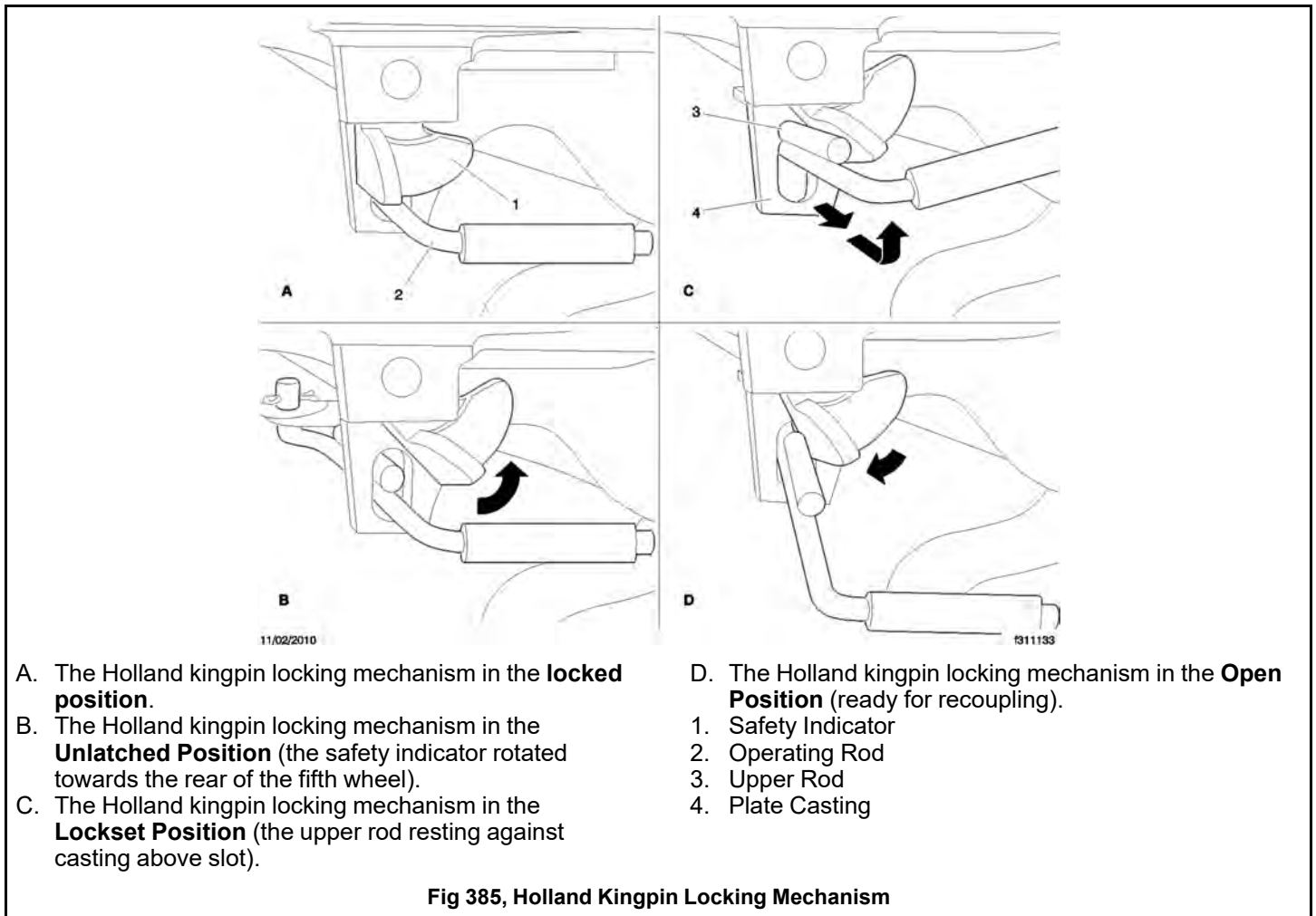

- 6.c **Jost:** Pull the retractable handle out, then secure it in the open position with the catch. See Fig. 386, [Jost Release Handle Unlocked](#).

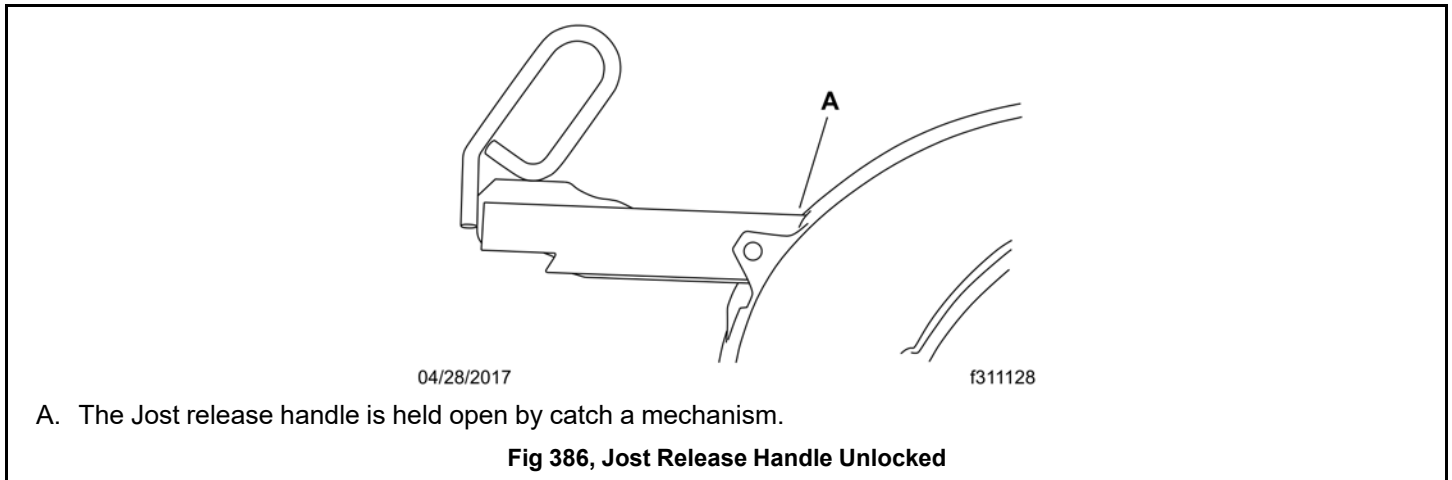

7. Release the tractor parking brake then drive out slowly, allowing the trailer to slide down the fifth wheel and pick-up ramps.

21.03.02 Air-Actuated Uncoupling

General Description, Air Actuated Uncoupling

A dash-mounted kingpin release switch (if equipped) may be used to uncouple the trailer. See Fig. 387, [Kingpin Release Switch](#).



NOTE: In the event of an air system failure, air-actuated kingpins can be manually released following the instructions for manual unlocking.



WARNING:

Once the kingpin release switch has been pushed, the kingpin lock is released. The vehicle **MUST NOT** be driven with the trailer until the trailer has been uncoupled and coupled again. Failure to do so may result in separation of the trailer from the tractor, possibly causing serious personal injury or death.

Preparing the Trailer for Uncoupling

Before using the air valve to unlock a fifth wheel kingpin, prepare the trailer as follows.

1. Apply the tractor and trailer parking brakes.
2. Chock the trailer rear wheels.

3. Lower the trailer landing gear until the weight is removed from the fifth wheel.
4. Disconnect the tractor-to-trailer air lines and electrical cable. Plug the air lines to prevent dirt or foreign material from entering the lines.

Air-Activated Kingpin Unlock

1. Verify that both the yellow parking-brake and red trailer-air supply knobs are out, the tractor and trailer parking brakes are set, and that the trailer is prepared for uncoupling.

NOTE: The kingpin release will not actuate if the switch is pushed for less than 3 seconds, the vehicle is moving, or the parking brake is not set. Unless all these conditions are met, the trailer is not uncoupled and an alert is shown on the driver display.

2. Push and hold the kingpin release switch (see Fig.388, [Kingpin Release Switch](#)) for a minimum of 3 seconds. The system will apply air for 20 to 30 seconds to ensure the kingpin unlocks. When the kingpin is unlocked, a notification is displayed; see Fig.389, [Kingpin Release Alert Screen](#).
3. Release the tractor parking brake.
4. Drive out from under the trailer.

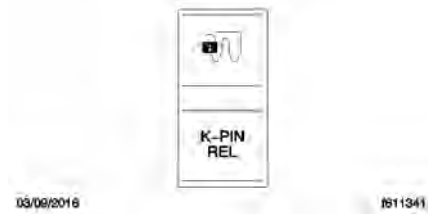

Fig 388, Kingpin Release Switch



06/14/2016

f611426

Fig 389, Kingpin Release Alert Screen

21.04 Fifth Wheel Slide

21.04.01 General Description, Fifth Wheel Slide



WARNING:

Adjust the fifth wheel slide correctly, and do not overload any tractor axle by incorrectly loading the trailer. Incorrect slide adjustment or improper axle loading could cause erratic steering and loss of vehicle control, possibly resulting in serious personal injury or death.

On sliding fifth wheel assemblies, the fifth-wheel plate is attached to rails that allow forward and rearward movement of the fifth wheel to optimally distribute the load across the axles. Slots are evenly spaced along the slide rails, and retractable wedges are positioned through the slots to hold the fifth wheel in the desired position.

The amount of load distribution on the front steering axle and rear drive axle(s) will have a direct effect on the steering control of the vehicle. Determine the front and rear axle weights by weighing the vehicle on scales designed for this purpose.

The maximum axle weight ratings are shown on the Federal Motor Vehicle Safety Standard (FMVSS) label or Canadian Motor Vehicle Safety Standard (CMVSS) label attached to the left rear door post of the tractor. The desired load on the axle is no less than 80 percent of the maximum axle weight rating, but in no instances should the axle load exceed the maximum axle weight rating given on the FMVSS or CMVSS label.

21.04.02 Operation of Manual Slide

The manual slide feature is operated from the fifth wheel plate with a manual release handle using the following procedure. See Fig.390, [Manual Release Sliding Fifth Wheel \(Fontaine shown\)](#).

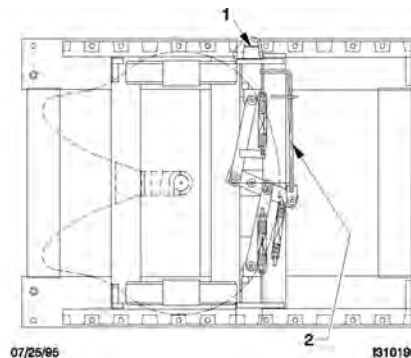

Fig 390, Manual Release Sliding Fifth Wheel (Fontaine shown)

1. Locking Wedge
2. Slide Release Pull Handle
 1. Stop the tractor and trailer in a straight line on level ground. Pull the red trailer air supply knob to apply the trailer parking brakes.
 2. Apply the tractor parking brake, then release the sliding mechanism using the appropriate method for the fifth wheel manufacturer.
 - 2.a **Fontaine:** Lift the slide release pull handle to disengage it from the guide plate. Then, pull out the handle until it is in the unlocked position and can be positioned against the guide plate to hold it out. The handle will stay in the unlocked position until it is manually disengaged from the guide plate. See Fig. 391, [Releasing the Sliding Fifth Wheel, \(Fontaine\)](#).

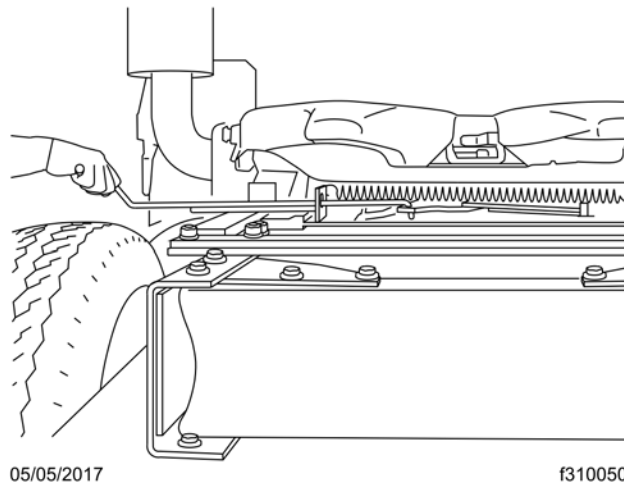
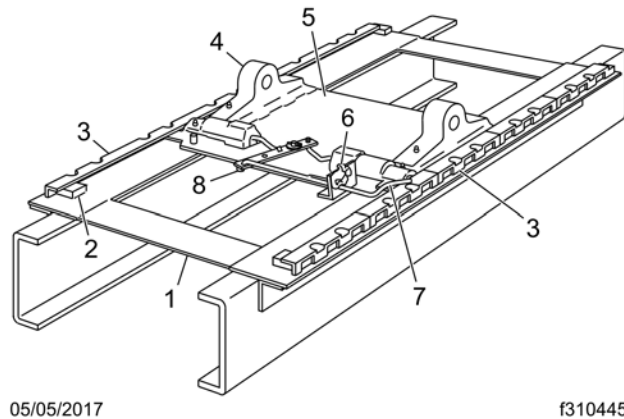

Fig 391, Releasing the Sliding Fifth Wheel, (Fontaine)

- 2.b **Holland:** Pull the operating rod out. Make sure both side plungers have released. See Fig. 392, [Sliding Fifth Wheel Manual Release, \(Holland Simplex\)](#).



1. Baseplate
2. Bolted Stop
3. Baseplate Rail
4. Fifth Wheel Mount

5. Slider Saddle Plate
6. Safety Latch
7. Operating Rod
8. Operating Lever

Fig 392, Sliding Fifth Wheel Manual Release, (Holland Simplex)

3. Lower the trailer landing gear just enough to remove the weight from the tractor.
4. Chock the front and rear of the trailer tires to prevent the trailer from moving.
5. Release the tractor parking brakes, then slowly move the tractor forward or backward until the fifth wheel is in the desired location.

**WARNING:**

Check that the locking wedges have seated in the slots. Failure to achieve complete lockup may allow disengagement of the tractor from the trailer, possibly resulting in serious personal injury or death.

**NOTICE:**

When moving the fifth wheel to the desired position, be sure the trailer landing gear will not at any time come in contact with the tractor frame or other components. Make sure that the front of the trailer will not come in contact with the rear of the cab or with other components if they extend beyond the rear of the cab.

6. Apply the tractor parking brakes, then lock the sliding member in position using one of the following methods:
 - 6.a **Fontaine:** Disengage the slide release pull handle from the guide plate. The slide release pull handle is spring-loaded in the locked position and will seek the locked position when disengaged from the guide plate. After the slide release pull handle returns to the fully locked position, visually and physically check the locking wedges to make sure they are fully inserted into the slots in the slide rails. Make sure the handle is locked in position against the guide plate.
 - 6.b **Holland:** Raise the operating rod so that it is free to move inward. Make sure that the lock pins have seated in the base plate rail holes and the operating rod moves into the locked position.

NOTE: The fifth wheel may need to be moved slightly to enable the locking wedges to enter the fully locked position.

21.04.03 Operation of the Air Slide

The slide feature may be operated with an air switch mounted in the dash, that operates an air cylinder that locks and unlocks the slide. See Fig.393, [Air-Slide Switch](#).

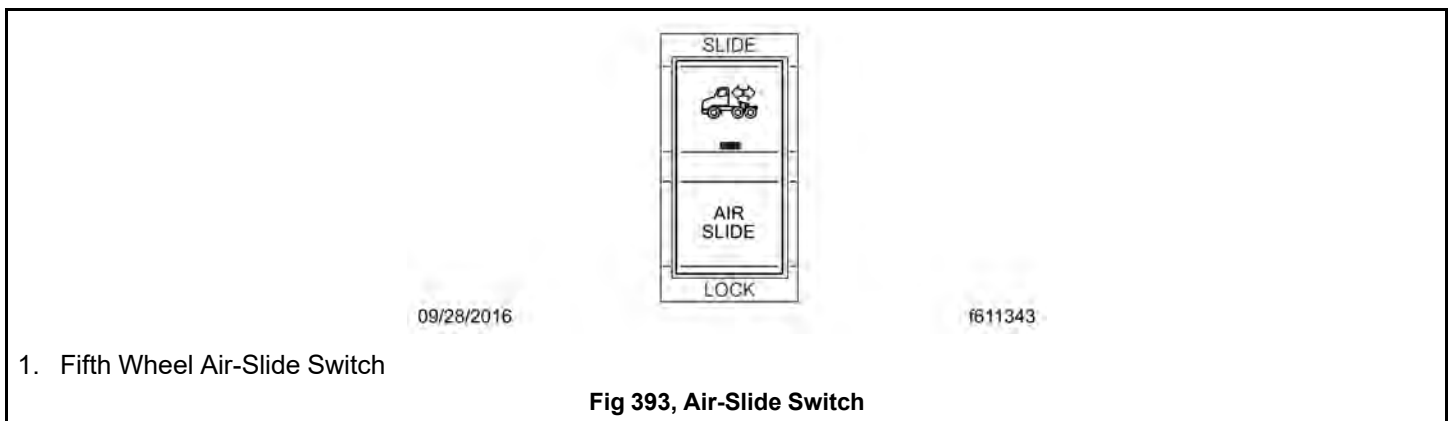

1. Set the air-slide switch (see Fig.393, [Air-Slide Switch](#)) to SLIDE.

Ensure the locking plungers have released. See Fig.394, [Air-Operated Sliding Fifth Wheel \(Fontaine shown\)](#).

For Jost fifth wheels, the mechanism activates as shown in Fig.395, [Jost Sliding Fifth Wheel](#).

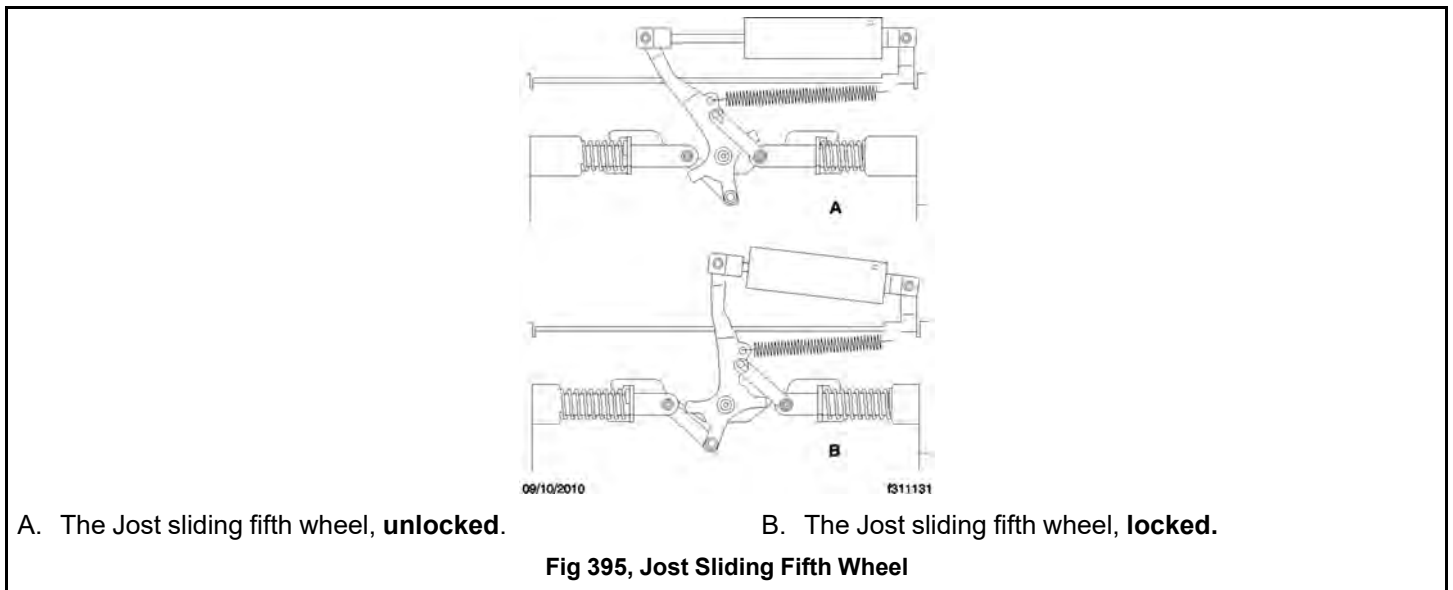
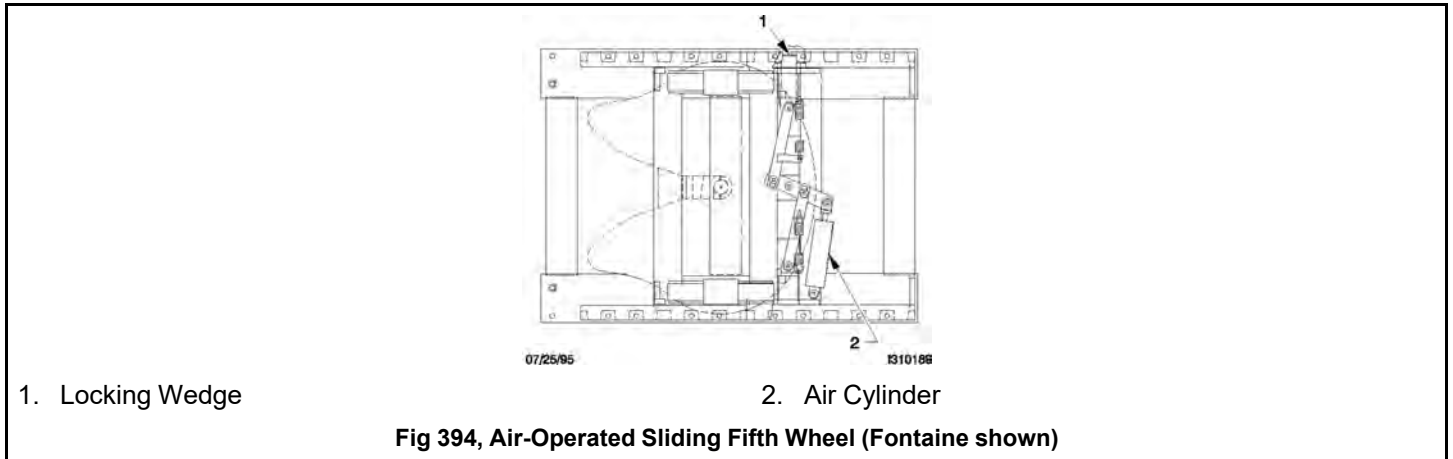

2. Lower the trailer landing gear just enough to remove the weight from the tractor.
3. Pull the red trailer-air-supply knob to set the trailer-parking brakes.
4. Slowly move the tractor forward or backward until the fifth wheel is in the desired location.

**NOTICE:**

Ensure the trailer landing gear does not come in contact with the tractor frame or other components, and that the front of the trailer will not come in contact with the rear of the cab or other components if they extend beyond the rear of the cab.

5. Apply the tractor parking brakes.

**WARNING:**

Check that the locking wedges have seated in the slots. Failure to achieve complete lockup may allow disengagement of the tractor from the trailer, possibly resulting in serious personal injury or death.

6. Set the air-slide switch to LOCK. Visually inspect the locking wedges or plungers to make sure that they are fully inserted in the slide rail slots. Verify that the plungers have engaged by tugging the tractor forward while the trailer brakes are locked and the wheels are chocked.

NOTE: The fifth wheel may need to be moved slightly to enable the locking wedges to fully lock.

| | |
|---|-----|
| 22.01 Coupling the Holland Trailer | 466 |
| 22.01.01 Holland Trailer, General Information | 466 |
| 22.01.02 Trailer Hookup | 467 |
| 22.01.03 Trailer Release | 467 |

22. Trailer Couplings

22.01 Coupling the Holland Trailer

22.01.01 Holland Trailer, General Information

IMPORTANT: Refer to the Holland web site, see (www.hollandhitch.com) for additional information.

The Holland trailer coupling is designed for use with trailers having a maximum gross weight of 10,000 lb. (4540 kg) for Holland PH-10RP41 and PH-10RP51, or 30,000 lb. (13,610 kg) for Holland PH-30RP41 and PH-30RP51. It is a rigid-type pintle hook, used only on tractor applications, and is fastened to the rear closing crossmember of the vehicle. It is a non-air-adjusted coupling. See Fig.396, [Holland Trailer Coupling with FastLatch](#) and Fig.397, [Holland Trailer Coupling with Lock Pin](#).

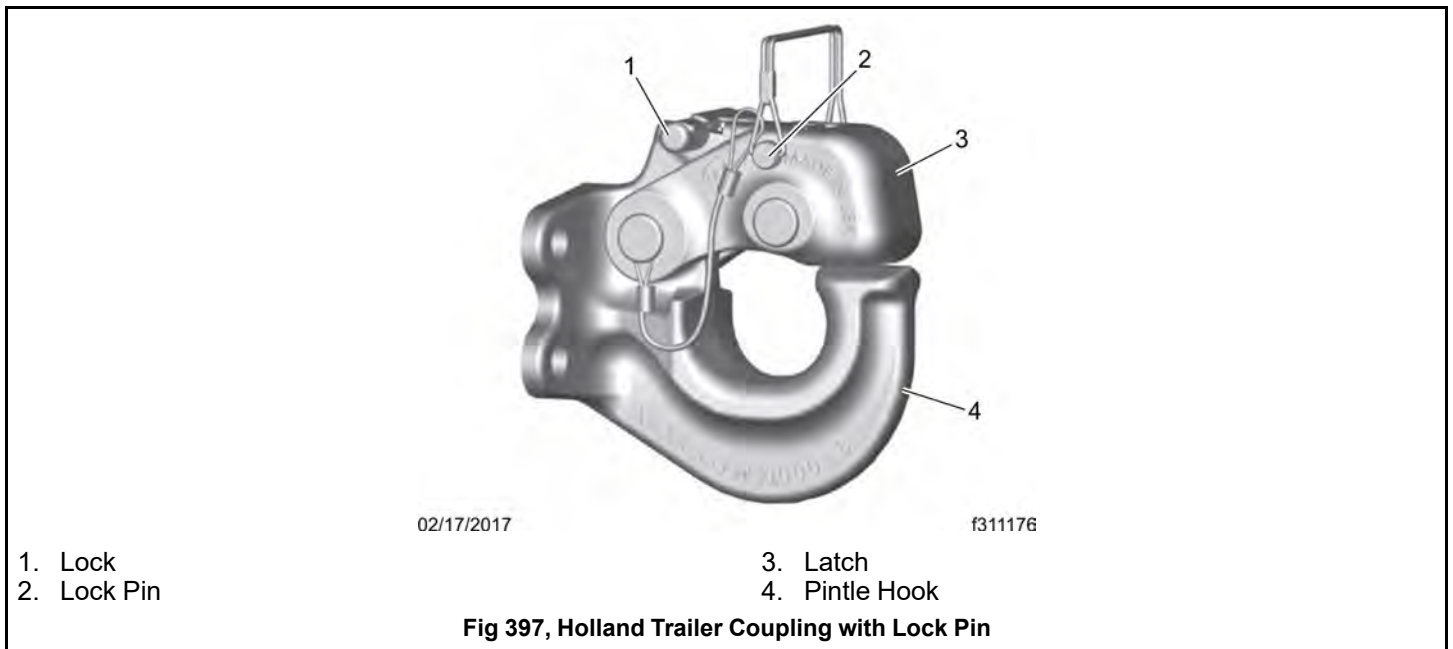
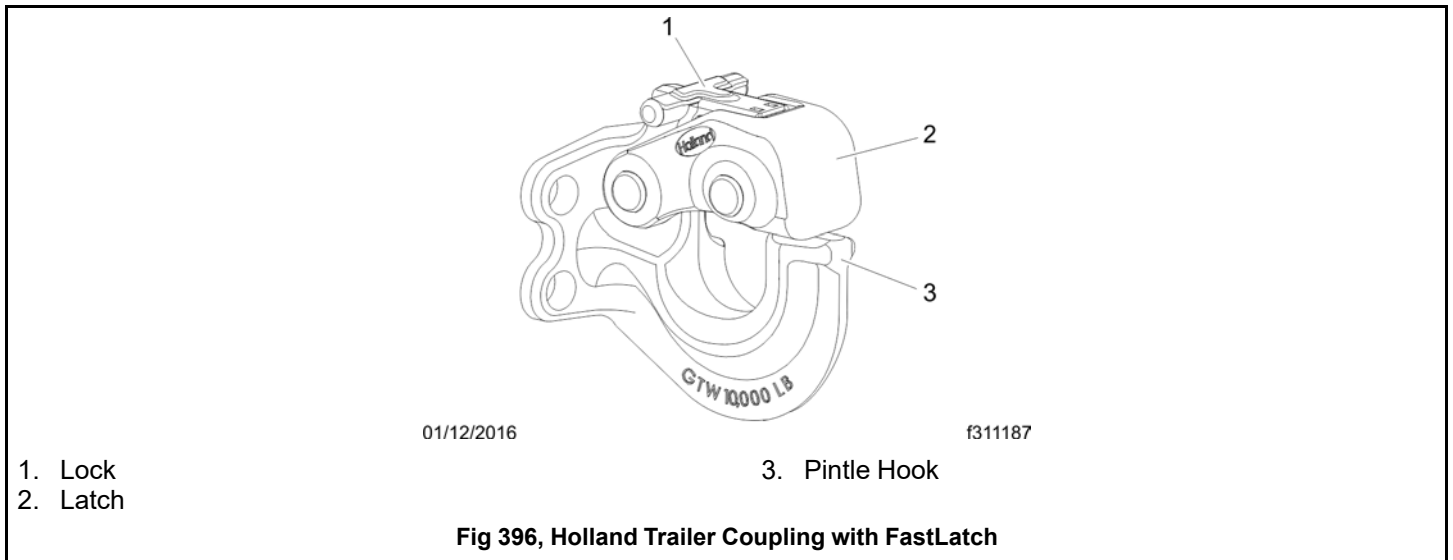

22.01.02 Trailer Hookup

1. Chock the front and rear tires of the trailer.
2. Remove the lock pin (if equipped), then lift the lock handle and raise the latch.
3. Back up the vehicle until the drawbar eye is over the pintle hook.
4. Lower the trailer, until the drawbar eye rests on the pintle hook.
5. Push the latch closed, then insert the lock pin (if equipped).

**NOTICE:**

Always make sure the connection hanger keeps the trailer air hoses and electrical cables positioned so that they do not rub on anything. Rubbing may wear through hoses or cables, resulting in air leaks, or exposed or broken wires, potentially affecting trailer brake or electrical systems.

6. Connect the trailer electrical and air lines.

22.01.03 Trailer Release

1. Apply the tractor and trailer parking brakes.

**WARNING:**

Do not use the trailer air supply for parking trailers not equipped with spring parking brakes. This applies the trailer service brakes only. As air bleeds from the trailer brake system, brake application is lost. This could allow the unattended vehicle to roll away, possibly resulting in serious personal injury or death.

2. Chock the front and rear tires of the trailer.
3. Disconnect the trailer air and electrical lines. Plug the air lines to keep them free of dirt.
4. Take the weight of the trailer drawbar off the pintle hook.
5. Open the latch by removing the lock pin (if equipped), then lift up the lock and raise the latch.
6. Slowly drive the vehicle away from the trailer.

23.01 Headlight Aiming, Preliminary Checks..... 470

23.02 Headlight Aim Check 470

23.03 Adjustment of the Headlight Aim..... 472

23.04 Replacement of the Halogen Headlamps Bulb 473

23. Headlights

23.01 Headlight Aiming, Preliminary Checks

Before checking or adjusting the headlight aim, do the following.

- Check that the hood is closed and latched.
- Remove any large amounts of mud or ice from the underside of the fenders.
- Check the springs for sagging or broken leaves.
- Check the suspension for proper functioning of the leveling mechanism. On cabs with air suspensions, make sure that the height is properly adjusted.
- Check for damage to the hood and hinge assembly. Repair as necessary.
- With the vehicle unloaded, check that the tires are inflated to the recommended air pressure.
- Clean the headlight lenses. Use a soft cloth with mild, non-caustic soap or detergent, and water.

23.02 Headlight Aim Check

1. Park the vehicle on a level surface, 25 ft (7.6 m) away from, and perpendicular to, a vertical screen or wall. Shut down the engine and set the parking brake. Chock the tires.
2. Each headlight has a height adjusting dot on the lens. See Fig.398, [Headlight](#). Measure the distance from the ground to the height adjusting dot on each headlight (see Fig.399, [Headlight Aiming Screen/Wall](#), Item A). Note those distances.



09/21/2016

f546613

- A. The height adjusting dot is located in front of the low-beam lamp on the headlight lens.

Fig 398, Headlight

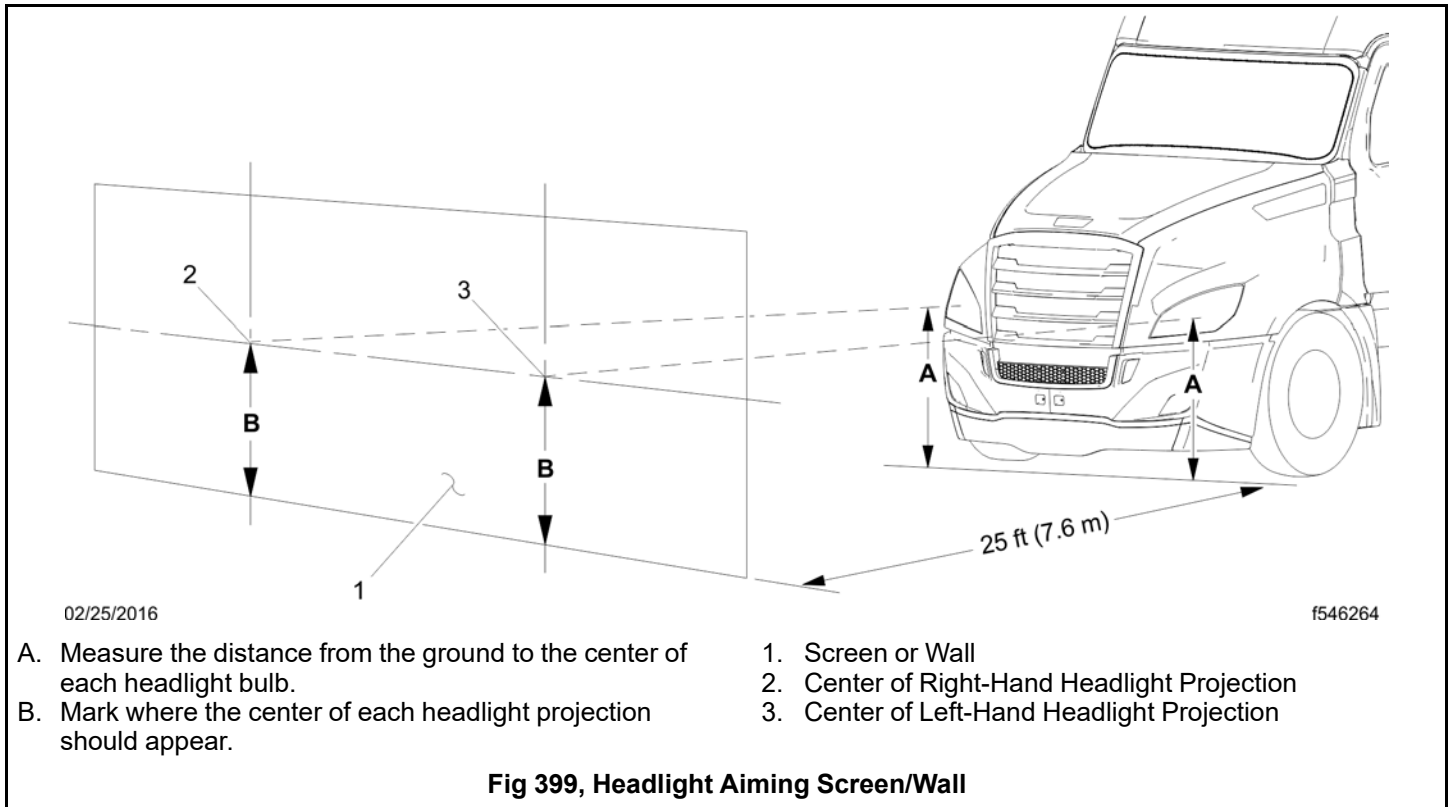

3. On the screen or wall, mark the locations of each headlight bulb center using the distances found in step 2. See Fig. 399, [Headlight Aiming Screen/Wall](#), Items 2 and 3.
4. Turn on the low-beam headlights.
5. Check the vertical adjustment of the low beams. The center of each beam projection should fall on or near the marks made during step 3. See Fig. 400, [Vertical Low-Beam Headlight Variation Limits](#).

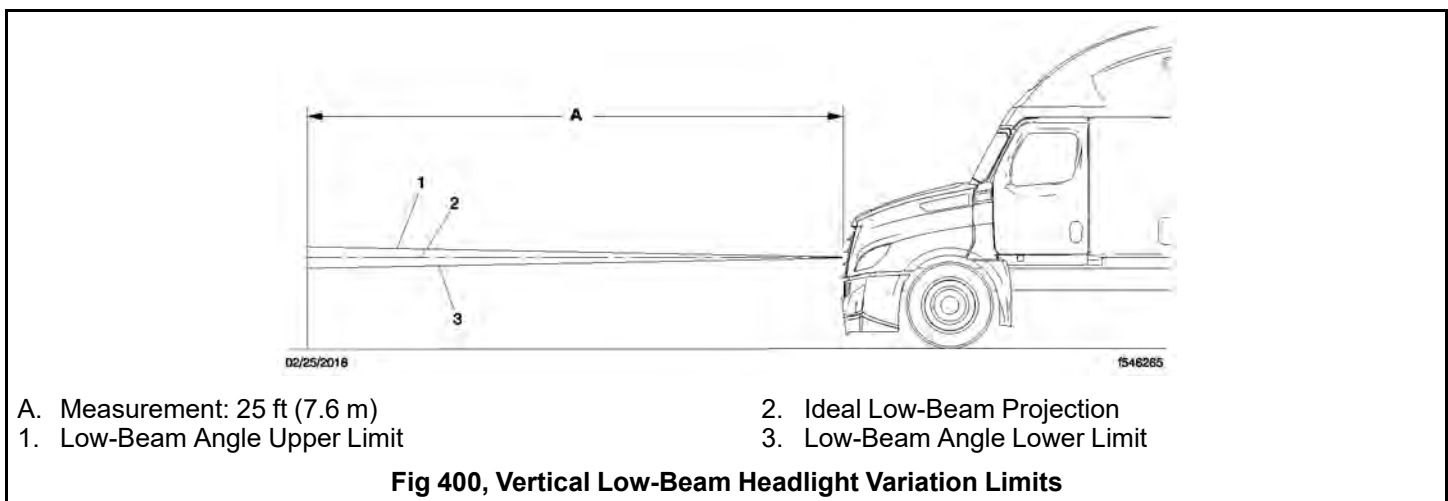

6. Use Table.46, [Vertical Low-Beam Headlight Variation Limits](#) to determine the maximum vertical distance allowable between the marks on the wall and the center of each low-beam projection.

If the distance between either projection center and the mark made on the wall or screen is greater than the maximum distance given in Table.46, [Vertical Low-Beam Headlight Variation Limits](#), adjust the vertical positioning of that headlight.

| Distance Between Ground and Headlight: inches (mm) | Desired Variation (Fig. 400, Vertical Low-Beam Headlight Variation Limits, Item 2): inches (mm) | Upper Limit (Fig. 400, Vertical Low-Beam Headlight Variation Limits, Item 1): inches (mm) | Lower Limit (Fig. 400, Vertical Low-Beam Headlight Variation Limits, Item 3): inches (mm) |
|--|--|--|--|
| 22–36 (560–900) | 0 | 3.9 (100) | 3.9 (100) |
| 36–48 (900–1200) | 2 (50) down | 2 (50) | 6 (150) |
| 48–54 (1200–1400) | 4 (101.6) down | 1.6 (40) | 6.5 (165) |

23.03 Adjustment of the Headlight Aim



NOTICE:

Do not use power tools to adjust headlight aim. Doing so will strip or break the adjusting screw.

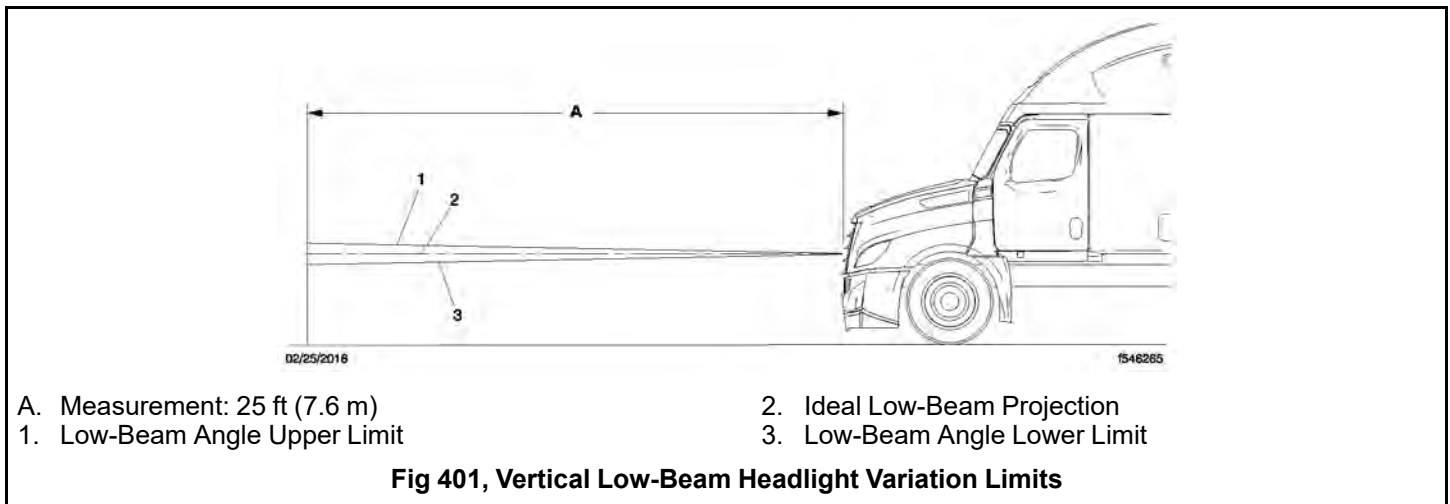

The adjusting screw is located on the bottom of the headlight assembly, accessible from inside the wheel well when the hood is closed. See Fig. 402, [Headlight Adjusting \(shown with the hood open\)](#). Remove the plug. Turn the adjusting screw clockwise to raise the beam and counterclockwise to lower it, until the beam pattern meets the acceptable standard.



02/25/2016

f546266

Fig 402, Headlight Adjusting (shown with the hood open)

| Distance Between Ground and Headlight: inches (mm) | Desired Variation (Fig. 401, Vertical Low-Beam Headlight Variation Limits, Item 2): inches (mm) | Upper Limit (Fig. 401, Vertical Low-Beam Headlight Variation Limits, Item 1): inches (mm) | Lower Limit (Fig. 401, Vertical Low-Beam Headlight Variation Limits, Item 3): inches (mm) |
|--|---|---|---|
| 22–36 (560–900) | 0 | 3.9 (100) | 3.9 (100) |
| 36–48 (900–1200) | 2 (50) down | 2 (50) | 6 (150) |
| 48–54 (1200–1400) | 4 (101.6) down | 1.6 (40) | 6.5 (165) |

23.04 Replacement of the Halogen Headlamps Bulb

IMPORTANT: Use only SAE/DOT approved H11 bulbs with a 55 watt rating for the headlamps. Use only SAE/DOT approved 4157 NAK LL lamps for turn signal and marker lamps. Installing higher wattage bulbs may damage the headlamp housing or the wiring.

There are three bulbs housed in the headlight bucket assembly. See Fig.403, [Halogen Headlamp Assembly](#). Each bulb can be replaced using the same procedure.

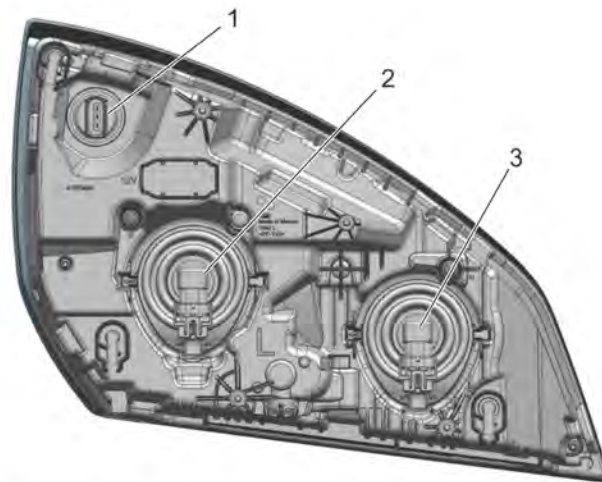

01/11/2019

f546929

- | | |
|---|-------------------------------------|
| 1. Turn Signal Lamp, 4157NAL LL, 28.5/8.3 Watt (dual element) | 2. Low Beam Headlamp, H11, 55 Watt |
| | 3. High Beam Headlamp, H11, 55 Watt |

Fig 403, Halogen Headlamp Assembly

1. Open the hood.
2. Remove the back cover from the headlamp housing.

NOTE: Remove the bulb from the headlamp assembly before disconnecting the electrical connector.

3. Remove the bulb from the headlamp assembly by twisting the bulb counterclockwise a quarter turn then lifting the bulb out of the headlamp assembly.
4. Squeeze the connector lock and slide the red locking tab down to disconnect the electrical connector. See Fig. 404, [Halogen Headlamp Electrical Connector](#).



01/11/2019

f546928

1. Red Locking Tab

Fig 404, Halogen Headlamp Electrical Connector



CAUTION:

Ensure that the bulb is installed correctly, and that it is firmly seated in the headlamp housing. Improper bulb installation may result in melting or fire damage to the vehicle.

IMPORTANT: Do not touch the glass of the bulb during replacement. Any oils or debris that come in contact with the glass of the bulb may shorten the life of the lamp.

5. Connect the electrical connector to the new lamp and slide the red locking tab up.
6. Position the bulb in the headlamp housing, then twist the bulb clockwise a quarter turn.
7. Visually verify from either the front or back that the bulb is correctly oriented in the headlamp housing.

See Fig.405, [Proper Bulb Installation, Front View](#) to verify from the front that the three tabs of the headlamp housing are correctly oriented.

See Fig.406, [Improper and Proper Bulb Installation, Back View](#) and Fig. 407, [Correct Halogen Headlamp Installation With Foam Grommet](#) to verify the correct installation from the back. The lamp is fully seated only when the connector is pointing straight down.



A

B

C

03/30/2020

f547167

NOTE: The reflective area of the headlamp has been painted white to show details of the assembly.

- A. Bulb Positioned in Headlamp Housing
- B. Bulb Twisted an Eighth of a Turn

- C. Bulb Twisted a Quarter Turn, Tabs Against Metal Stops

Fig 405, Proper Bulb Installation, Front View



A

B

C

03/17/2020

f547134

- A. Bulb Positioned in Headlamp Housing
- B. Bulb Twisted an Eighth of a Turn

- C. Connector Pointing Straight Down

Fig 406, Improper and Proper Bulb Installation, Back View



11/04/2019

f547046

Fig 407, Correct Halogen Headlamp Installation With Foam Grommet

8. Install the back cover on the headlamp housing.

| | |
|---|-----|
| 24.01 Cab Washing and Polishing..... | 480 |
| 24.02 Care of Fiberglass Parts | 480 |
| 24.03 Care of Chrome Parts | 480 |
| 24.04 Care of Exterior Lights | 481 |
| 24.05 Dashboard and Instrument Panel Care | 481 |
| 24.06 Cleaning the Vinyl Upholstery..... | 481 |
| 24.07 Cleaning the Velour Upholstery | 482 |

24. Vehicle Appearance and Care

24.01 Cab Washing and Polishing

IMPORTANT: Carefully read all instructions before using or applying any cleaner or product on the vehicle or components. Failure to follow manufacturers' recommendations can result in damage to the finish.



WARNING:

Do not power wash or steam clean the engine bay in the area of vehicle electrical components, unless specified by vehicle manuals or service literature. Power washing and steam cleaning can cause corrosion, permanently damaging these components, which could result in fire, personal injury, or property damage.

To protect the finish of your new vehicle, follow these guidelines carefully.

- During the first 30 days, rinse your vehicle frequently with water. If the vehicle is dirty, use a mild liquid soap. Do not use detergent.
- During the first 30 days, do not use anything abrasive on your vehicle. Brushes, chemicals, and cleaners may scratch the finish.
- During the first 120 days, do not wax your vehicle.

To extend the life of your vehicle's finish, follow these guidelines.

- Avoid washing your vehicle in the hot sun.
- Always use water. After the cab is completely washed, dry it with a towel or chamois.
- Do not dust painted surfaces with a dry cloth, as this will scratch the paint.
- Do not remove ice or snow from a painted surface with a scraper of any sort.
- To prevent damage to the finish, wax it regularly. Before waxing, if the finish has become dull, remove oxidized paint using a cleaner specifically designed for this purpose. Remove all road tar and tree sap before waxing. Freightliner recommends that a quality brand of cleaner or cleaner-polish and polishing wax be used.
- Do not let diesel fuel or antifreeze stand on a painted surface. If either should occur, rinse the surface off with water.
- To prevent rust, have any nicks or other damage on the finish touched up as soon as possible.
- Park your vehicle in a sheltered area whenever possible.

To prevent delamination and deterioration of labels and stickers on the cab, follow these guidelines carefully:

- Do not pressure wash the label or sticker or surfaces near it.
- Do not use strong alkaline soaps on or near the label or sticker.

24.02 Care of Fiberglass Parts

Wash unpainted fiberglass air fairings and shields monthly with a mild detergent, such as dishwashing liquid. Avoid strong alkaline cleansers.

Apply a wax specifically designed for fiberglass.

24.03 Care of Chrome Parts

To prevent rust, keep chrome parts clean and protected at all times. This is especially important during winter driving and in coastal areas where there is exposure to salt air.

When cleaning chrome parts, use clean water and a soft cloth or sponge. A mild detergent may also be used.

Sponge gently, then rinse. If necessary, use a nonabrasive chrome cleaner to remove stubborn rust or other material. Do not use steel wool.

To help protect the chrome after cleaning, apply a coat of polishing wax to the surface. Never use wax on parts that are exposed to high heat, such as exhaust pipes.

24.04 Care of Exterior Lights

Clean the headlight lenses by hand only, using a flannel cloth with mild, non-caustic soap or detergent, and water.

**NOTICE:**

Do not use a power buffer, paper towels, chemical solvents, or abrasive cleaners on the headlight lens, all of which can remove the UV coating from the surface, and result in yellowing of the lens.

24.05 Dashboard and Instrument Panel Care

**NOTICE:**

When cleaning the dashboard, instrument panel, or gauge lens covers, do not use Armor-All Protectant®, STP Son-of-a-Gun®, window cleaner, or other equivalent treatments. These cleaners contain vinyl plasticizers which can cause stress crazing in the interior plastic panels and can result in cracking of the panels. Some cleaners can also have an adverse effect on the clear plastic of instrument panels and gauge lens covers, resulting in a foggy or cloudy appearance. This type of damage is not covered by vehicle warranty.

To clean the dashboard, instrument panel, and gauge lens covers, use a cloth dampened with warm soapy water. Make certain to wring the cloth out well before cleaning, as excess water will damage the electrical components.

24.06 Cleaning the Vinyl Upholstery

To prevent soiling, frequent vacuuming or light brushing to remove dust and dirt is recommended. Harsh cleaning agents can cause permanent damage to vinyl upholstery. To preserve the upholstery and prevent damage, carefully review the following sections for recommended cleaning procedures. Waxing or refinishing improves soil resistance and cleanability for all vinyls. Any hard wax, such as that used on automobiles, may be used.

Ordinary Dirt

Wash the upholstery with warm water and mild soap, such as saddle or oil soap. Apply soapy water to a large area and allow to soak for a few minutes, then rub briskly with a cloth to remove the dirt. This can be repeated several times, as necessary.

If dirt is deeply imbedded, use a soft bristle brush after applying the soap.

If dirt is extremely difficult to remove, wall-washing preparations normally found around the home can be used. Powdered cleaners, such as those used for sinks and tiles, are abrasive and must be used with caution as they can scratch the vinyl or give it a permanent dull appearance.

Chewing Gum

Harden the gum with an ice cube wrapped in a plastic bag, then scrape it off with a dull knife. Any remaining traces of gum can be removed with an all-purpose light oil (peanut butter will also work) and wiped off.

Tars, Asphalts, and Creosote

Each of these items stains vinyl after prolonged contact. They should be wiped off immediately and the area carefully cleaned, using a cloth dampened with naphtha.

Paint, Shoe Heel Marks

Paint should be removed immediately. Do not use paint remover or liquid-type brush cleaner on vinyl. An unprinted cloth, dampened with naphtha or turpentine may be used. Use care to prevent contact with parts of the upholstery that are not vinyl.

Sulfide Stains

Sulfide compounds, such as those found in eggs and some canned goods, can stain after prolonged contact with vinyl. These stains can be removed by placing a clean, unprinted piece of cloth over the spotted area and pouring a liberal amount of 6 percent hydrogen peroxide onto the cloth. Allow the saturated cloth to remain on the spot for 30 to 60 minutes. For stubborn spots, allow the hydrogen-peroxide saturated cloth to remain on the area overnight. Use caution to prevent the solution from seeping into the seams, or it will weaken the cotton thread.

Nail Polish and Nail Polish Remover

Prolonged contact with these substances causes permanent damage to vinyl. Careful blotting immediately after contact minimizes damage. Do not spread the liquid during removal.

Shoe Polish

Most shoe polishes contain dyes which penetrate vinyl and stain it permanently. Shoe polish should be wiped off as quickly as possible using naphtha or lighter fluid. If staining occurs, try the procedure used for sulfide stains.

Ball Point Ink

Ball point ink can sometimes be removed if rubbed immediately with a damp cloth, using water or rubbing alcohol. If this does not work, try the procedure used for sulfide stains.

Miscellaneous

If stains do not respond to any of the treatments described above, it is sometimes helpful to expose the vinyl to direct sunlight for up to 30 hours. Mustard, ball point ink, certain shoe polishes, and dyes often bleach out in direct sunlight, leaving the vinyl undamaged.

24.07 Cleaning the Velour Upholstery

To prevent soiling, frequent vacuuming or light brushing to remove dust and dirt is recommended. Spot clean with a mild solvent or an upholstery shampoo, or the foam from a mild detergent. When using a solvent or a dry-cleaning product, follow the instructions carefully, and clean only in a well-ventilated area. Avoid any product that contains carbon tetrachloride or other toxic materials. With either method, pretest a small area before proceeding. Use a professional upholstery cleaning service when extensive cleaning is needed.

Grease and Oil-Based Stains

Dampen a small absorbent cloth with dry-cleaning solvent or spot remover. Apply the cloth carefully to the spot from the outer edge to the center. Pat and blot the spot with a clean, dry cloth. Repeat several times, as necessary, turning the cloths so that the stain does not redeposit on the fabric.

Sugar and Water-Based Stains

Apply water-based detergent or cleaner, working in circular motions. Pat and blot as dry as possible. Repeat, if necessary, before drying thoroughly.

Chewing Gum or Wax

Harden the gum or wax with an ice cube wrapped in a plastic bag, then scrape it off with a dull knife. Excess wax can be absorbed by placing a thick white blotter over the wax and heating with a warm (not hot) iron. Remove the remainder by using the procedure for grease and oil-based stains.

Mildew

Brush the dry fabric with a soft brush. Sponge with detergent, and blot. If the fabric is colorfast, dilute a teaspoon of bleach in one quart (one liter) of cool water. Apply with a swab, directly on the mildew stain. Dab repeatedly with clear, cool water, and blot dry.

| | |
|---|-----|
| 25.01 Periodic Inspections and Maintenance, General Information | 486 |
| 25.02 Checklists | 486 |
| 25.02.01 Daily Pretrip Inspection Checklists | 486 |
| 25.02.02 Weekly Post-trip Inspection Checklist | 488 |
| 25.02.03 Monthly Post-trip Inspection Checklists | 488 |
| 25.03 Fluids Added | 489 |

25. Pre- and Post-Trip Checklists

25.01 Periodic Inspections and Maintenance, General Information

It is the driver's responsibility to perform an inspection, and ensure the complete road-worthiness of a vehicle, before placing it into service. Commercial vehicles may be subject to inspection by authorized inspectors, and an unsafe vehicle can be taken 'out of service' until the driver or owner repairs it.

Use the following checklists to ensure that vehicle components are in good working condition before each trip. Careful inspections eliminate stops later to fix overlooked or forgotten items.

The checklists in this chapter can be copied and kept as a record that the procedures have been completed. For details on how to inspect each item on the checklists, see the corresponding procedure (step number), see [26.01 Safety Precautions](#).

25.02 Checklists

25.02.01 Daily Pretrip Inspection Checklists

NOTE: Checklists in this chapter correspond with the procedures and steps, see [26.01 Safety Precautions, Pre- and Post-Trip Inspections and Maintenance](#). Your vehicle may not be equipped with all components listed below.

See the following tables for a list of procedures that should be performed daily, before the first trip. Place a check mark in the complete (**Comp.**) column to indicate a procedure has been performed.

| Inspector | Date |
|-----------|------|
| | |

| Suspension and Slack Adjusters | | Comp. |
|--------------------------------|-----------------------|-------|
| 1 | Suspension components | |
| 2 | Slack adjusters | |

| Wheels and Tires | | Comp. |
|------------------|--|-------|
| 1 | Wheel covers | |
| 2 | Tire condition | |
| 3 | Tire inflation | |
| 4 | Rims and wheel components | |
| 5 | Wheel bearing oil seals and lubrication levels | |
| 6 | Mud Flaps | |

| Saddle Tank Area | | Comp. |
|-------------------------|---|--------------|
| 1 | Drain air reservoirs (without automatic drain valves) | |
| 2 | Fuel tank(s) secure | |
| 3 | Frame rails and crossmembers | |
| 4 | Visible exhaust components | |

| Engine Compartment | | Comp. |
|---------------------------|--------------------------------|--------------|
| 1 | Leakage under engine | |
| 2 | Air intake system | |
| 3 | Engine oil level | |
| 4 | Power steering reservoir level | |
| 5 | Engine coolant level | |
| 6 | Visible engine wiring | |
| 7 | Frame rails | |

| Cab | | Comp. |
|------------|---|--------------|
| 1 | Reset dash-mounted air intake restriction indicator (if equipped) | |
| 2 | Air pressure warning systems | |
| 3 | Air governor cut-in and cut-out pressures | |
| 4 | Air pressure build-up time | |
| 5 | Air system leakage | |
| 6 | Air pressure reserve | |
| 7 | Mirrors, windows, windshield | |
| 8 | Horn, windshield wipers, windshield washers | |
| 9 | Heater and defroster | |
| 10 | Interior lights | |
| 11 | Exterior lights | |

| Cab | | Comp. |
|-----|-----------------------------|-------|
| 12 | Seat belts and tether belts | |
| 13 | Fuel level | |
| 14 | Mirror adjustment | |
| 15 | Service brakes | |
| 16 | Backup alarm | |

25.02.02 Weekly Post-trip Inspection Checklist

NOTE: Checklists in this chapter correspond with the procedures and steps in the chapter titled **Pre- and Post-Trip Inspections and Maintenance**. Your vehicle may not be equipped with all components listed below.

See the following table for procedures that should be performed weekly, post-trip. Place a check mark in the complete (**Comp.**) column to indicate a procedure has been performed.

| Inspector | Date |
|-----------|------|
| | |

| Engine Compartment | | Comp. |
|--------------------|------------------------------------|-------|
| 1 | Windshield washer reservoir level | |
| 2 | Air intake restriction indicator | |
| 3 | Water evacuation components | |
| 4 | Automatic transmission fluid level | |
| 5 | Water in fuel/water separator | |
| 6 | Steering components | |
| 7 | Serpentine drive belts | |

25.02.03 Monthly Post-trip Inspection Checklists

NOTE: Checklists in this chapter correspond with the procedures and steps, see [26.01 Safety Precautions](#), **Pre- and Post-Trip Inspections and Maintenance**. Your vehicle may not be equipped with all components listed below.

See the following tables for procedures that should be performed monthly, post-trip. Place a check mark in the complete (**Comp.**) column to indicate a procedure has been performed.

| Inspector | Date |
|-----------|------|
| | |

| Brake Components | | Comp. |
|------------------|-------------------------------|-------|
| 1 | Brake system components | |
| 2 | Brake chambers | |
| 3 | Air brake lines | |
| 4 | Flex air hoses | |
| 5 | Brake linings and brake drums | |
| 6 | Brake lining thickness | |

| Saddle Tank Areas | | Comp. |
|-------------------|--|-------|
| 1 | Drain air reservoirs (with automatic drain valves) | |
| 2 | Batteries (location may vary) | |
| 3 | Aerodynamic components | |

| Engine Compartment | | Comp. |
|--------------------|----------------------------|-------|
| 1 | Hood and bumper | |
| 2 | Hydraulic clutch reservoir | |
| 3 | Radiator and heater hoses | |
| 4 | Steering wheel play | |

25.03 Fluids Added

Use the following table to note any fluids that were added during the inspection and maintenance procedures.

| Fluid | Amount Added |
|-------------------------|--------------|
| Wheel Bearing Lubricant | |
| Engine Oil | |
| Power Steering Fluid | |
| Engine Coolant | |
| Windshield Washer Fluid | |

Table 48, Fluids Added During Inspection

| Fluid | Amount Added |
|--|--------------|
| Automatic Transmission Fluid | |
| Hydraulic Clutch Fluid (DOT 4 brake fluid) | |

| | |
|--|-----|
| 26.01 Safety Precautions | 492 |
| 26.02 Daily Pretrip Inspections and Maintenance | 492 |
| 26.02.01 General Information, Daily Pre-Trip Inspections and Maintenance | 492 |
| 26.02.02 Inspection of the Suspension and Slack Adjuster | 492 |
| 26.02.03 Inspection of the Wheel and Tire | 494 |
| 26.02.04 Inspection of the Saddle Tank Areas | 497 |
| 26.02.05 Inspection of the Engine Compartment | 498 |
| 26.02.06 Inspection of the Cab..... | 500 |
| 26.03 Weekly Post-Trip Inspections and Maintenance | 506 |
| 26.03.01 Inspection of the Engine Compartment | 506 |
| 26.04 Monthly Post-Trip Inspections and Maintenance | 510 |
| 26.04.01 Inspection of the Brake Component..... | 510 |
| 26.04.02 Inspection of the Saddle Tank Areas..... | 511 |
| 26.04.03 Inspection and Adjustments of the Engine Compartment..... | 512 |

26. Pre- and Post-Trip Inspections and Maintenance

26.01 Safety Precautions

**DANGER:**

When working on the vehicle, shut down the engine, set the parking brake, and chock the tires. before working under the vehicle, always place jack stands under the frame rails to ensure the vehicle can not drop. Failure to follow these steps could result in serious personal injury or death.

26.02 Daily Pretrip Inspections and Maintenance

26.02.01 General Information, Daily Pre-Trip Inspections and Maintenance

Complete the following inspection and maintenance procedures to ensure that vehicle components are in good working condition before each trip. A driver who is familiar with the vehicle and drives it regularly can perform the daily inspections, then add the weekly and monthly post-trip inspections as scheduled.

If the driver does not operate the vehicle on a consistent basis, all daily, weekly, and monthly inspection and maintenance procedures should be performed before the trip.

IMPORTANT: The pre- and post-trip checklists, inspections, and maintenance procedures detailed in this chapter are **not all-inclusive**. Refer to other component and body manufacturers' instructions for specific inspection and maintenance instructions, as well as local, state, and federal guidelines.

NOTE: If any system or component does not pass this inspection, it must be corrected before operating the vehicle. Whenever equipment requires adjustment, replacement, and/or repair, see the **Workshop Manual** for procedures and specifications.

26.02.02 Inspection of the Suspension and Slack Adjuster

Walk around the vehicle and visually inspect suspension and slack adjuster components.

1. Inspect the following suspension components for signs of structural damage, cracks, or wear.
 - springs
 - spring hangers
 - shocks
 - suspension arms
 - suspension brackets
 - axle seats
 - bushings
2. Inspect slack adjusters for signs of damage. See Fig.408, [Gunite Automatic Slack Adjuster](#), Fig. 409, [Haldex Automatic Slack Adjuster](#), or Fig.410, [Meritor Automatic Slack Adjuster](#).

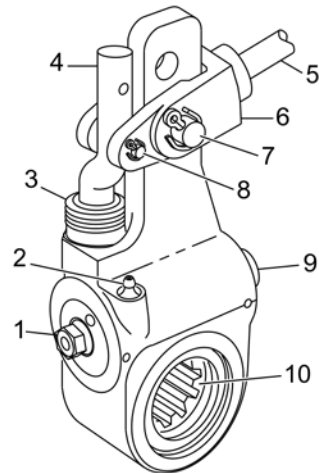

02/03/2017

f421398

- | | |
|-----------------------------|---------------------------|
| 1. 7/16-inch Adjusting Nut | 6. Clevis |
| 2. Grease Fitting | 7. 1/2-inch Clevis Pin |
| 3. Boot | 8. 1/4-inch Clevis Pin |
| 4. Link | 9. Grease Relief Opening |
| 5. Brake Chamber Piston Rod | 10. Slack Adjuster Spline |

Fig 408, Gunite Automatic Slack Adjuster

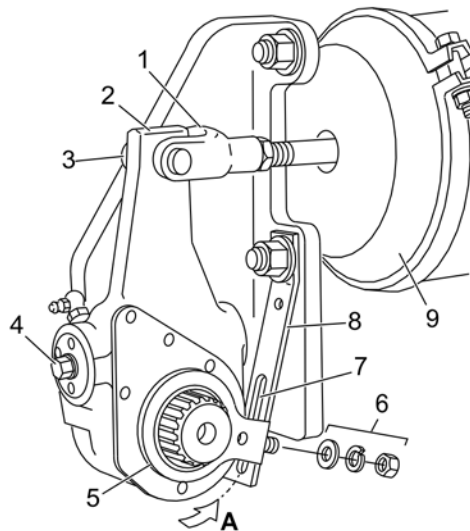

02/03/2017

f421397

- | | |
|-------------------------|--------------------------------|
| 1. Clevis | 6. Control-Arm Washers and Nut |
| 2. Slack Adjuster | 7. Anchor Strap Slot |
| 3. Clevis Pin | 8. Anchor Strap |
| 4. Manual Adjusting Nut | 9. Brake Chamber |
| 5. Control Arm | |

Fig 409, Haldex Automatic Slack Adjuster

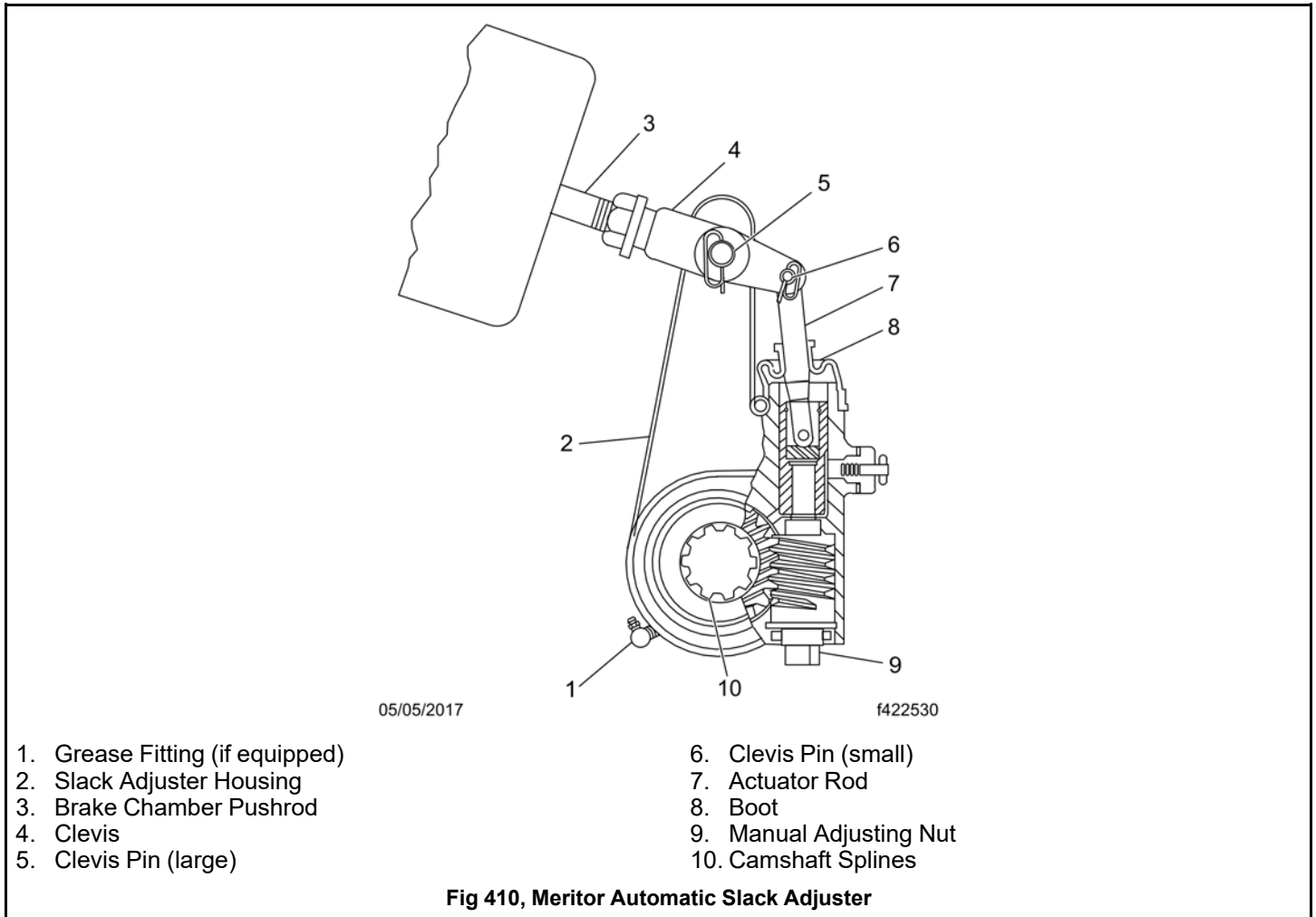

- Inspect slack adjuster boots, if equipped, for cuts or tears.
- Inspect anchor straps, if equipped, for damage.
- Look for worn clevis pins on brake chamber pushrods.
- Look for missing or damaged cotter pins on the clevis pins.
- Ensure chamber piston rods are in line with the slack adjusters.

26.02.03 Inspection of the Wheel and Tire

Walk around the vehicle and visually inspect each wheel and tire assembly.

IMPORTANT: Wheel covers decrease drag force as a vehicle moves, thereby improving fuel efficiency. If replacement of a wheel cover is necessary, the replacement cover must meet or exceed the drag reduction performance of the originally installed cover in order to maintain compliance with greenhouse gas and fuel efficiency regulations.

1. If the vehicle was originally equipped with wheel covers, ensure all wheel covers are present. Inspect wheel covers for damage or wear. Remove wheel covers from rear drive wheels, if equipped, prior to inspecting the tires and wheel components.

NOTE: During wheel cover installation, ensure the V-notch in the liner inner retaining ring is centered on the valve stem. The inner and outer retaining rings should be uniformly aligned to each other and to the wheel rim. The outer retaining ring of the liner is equipped with two canvas flaps. When installing the face cover, make sure the cover retaining ring is inserted between the two canvas flaps on the liner outer retaining ring so that the Velcro strips line up between the face cover and the liner. Make certain the detachable view cover is centered on the face cover, and the Velcro strips are pressed firmly in place.

2. Inspect each tire for the following:

- valve stem caps on every tire, screwed on finger-tight
- bulges, cracks, cuts, and penetrations
- oil contamination (petroleum derivatives will soften the rubber and destroy the tire)
- tread depth—if tread is less than 4/32 inch (3 mm) on any front tire, or less than 2/32 inch (1.5 mm) on any rear tire, replace the tire
- debris lodged between dual tire sets

IMPORTANT: Low-rolling resistance (LRR) tires minimize wasted energy as a tire rolls, thereby decreasing rolling effort and improving fuel efficiency. If tire replacement is necessary, replacement tires must meet or have less rolling resistance than the originally installed tires in order to maintain compliance with greenhouse gas and fuel efficiency regulations. Contact your tire manufacturer/supplier to determine the rolling resistance of the originally installed tires. Visit www.epa.gov/smartway for additional information and resources.

3. Check tire inflation.

For inflation pressures and maximum loads, see the tire manufacturer's guidelines. Inflate the tires to the applicable pressures if needed.

If a tire has been run flat or under-inflated, check the wheel and tire for damage before adding air.

Keep compressed air reservoirs and lines dry during tire inflation. Use well-maintained inline moisture traps and service them regularly.

**WARNING:**

Do not operate the vehicle with underinflated or overinflated tires. Incorrect inflation can stress the tires and make the tires and rims more susceptible to damage, possibly leading to rim or tire failure and loss of vehicle control, resulting in serious personal injury or death.

IMPORTANT: The load and cold inflation pressure must not exceed the rim or wheel manufacturer's recommendations, even though the tire may be approved for a higher load inflation. Consult the rim or wheel manufacturer for the correct tire inflation pressure for the vehicle load.

**NOTICE:**

A weekly pressure loss of 4 psi (28 kPa) or more in a tire may indicate damage. The tire should be inspected and, if necessary, repaired or replaced by a qualified tire service facility.

4. Examine each rim and wheel component.
 - 4.a Remove all dirt and debris from the assembly. Rust streaks or metal build-up around stud holes, or out-of-round or worn stud holes, may be caused by loose wheel nuts.

**WARNING:**

Have any worn or damaged wheel components replaced by a qualified person using the wheel manufacturer's instructions and the wheel industry's standard safety precautions and equipment. Otherwise a vehicle or workshop accident could occur, possibly resulting in serious personal injury or death.

- 4.b Inspect for broken, cracked, badly worn, bent, rusty, or sprung rings and rims.

**NOTICE:**

Use the recommended torque values and follow the proper tightening sequence. Insufficient wheel nut torque can cause wheel shimmy, resulting in wheel damage, stud breakage, and extreme tire tread wear. Excessive wheel nut torque can break studs, damage threads, and crack discs in the stud hole area.

- 4.c Make sure all wheel nuts are tightened. If tightening is necessary, use the tightening pattern in Fig. 411, [Tightening Pattern, 10-Hole Wheels](#) to initially tighten the flange nuts to 50 to 100 lbf·ft (68 to 136 N·m). Then tighten the flange nuts to 450 to 500 lbf·ft (610 to 678 N·m).

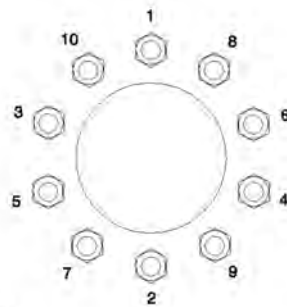

Fig 411, Tightening Pattern, 10-Hole Wheels

5. Inspect the outboard side of all wheel hubs and the hub oil seal area on the inboard side of each wheel for signs of oil leakage. If any oil is found on wheel and tire or brake components, remove the vehicle from service until the leak has been fixed.

If needed, fill the hubs to the level indicated on the hub cap. See **Group 35** of the **Maintenance Manual** for recommended lubricants.

6. Check that mud flaps are undamaged and hang 10 inches (25.4 cm) or less from the ground.

26.02.04 Inspection of the Saddle Tank Areas



WARNING:

When draining the air reservoir, do not look into the air jets or direct them toward anyone. Dirt or sludge particles may be in the airstream and could cause injury.



NOTICE:

If the water drained from the air reservoirs is cloudy or oily, it may indicate a problem with the compressor. If oil is allowed to contaminate the air dryer, it will not remove the water from the air brake system, which could adversely affect braking.

1. Drain the brake system air reservoirs (reservoirs without automatic drain valves only).



WARNING:

Never operate the engine with the fuel tank shutoff valves partially closed. This could damage the fuel pump, causing sudden loss of engine power, possibly resulting in serious personal injury due to reduced vehicle control.

2. Ensure fuel tanks are secured to their mounting brackets and that the mounting brackets are secured to the frame.
If equipped with fuel tank shutoff valves, be sure the valves are fully open.

3. Inspect visible frame rails for missing bolts, shiny areas, or rust streaks. Check all visible crossmembers for damage or signs of looseness.
4. Inspect visible components of the exhaust system to ensure connections are tight.

Inspect upstream of the aftertreatment device (ATD), if equipped, for cracking or signs of leaks, such as soot trails. Inspect downstream of the ATD for signs of exhaust leaks, such as blistering or warping of nearby components.

26.02.05 Inspection of the Engine Compartment

1. Check the ground underneath the engine for fuel, oil, or coolant leaks.
2. Inspect the air intake system for leaks or damage.

**NOTICE:**

Failure to maintain a sealed air intake system could allow the entry of dirt and contaminants into the engine. This could adversely affect engine performance and result in engine damage.

- 2.a Push the reset button on the air intake restriction indicator, if equipped.

NOTE: The air intake restriction indicator may be located on the air intake or the dash.

- 2.b Check the air intake duct from the air cleaner to the engine intake. Make sure the duct components are secure and airtight.
3. Check the engine oil level.

**NOTICE:**

Operating the engine with the oil level below the minimum fill (or "add") mark or above the maximum fill (or "full") mark could result in engine damage.

- 3.a Check the oil level with the vehicle parked on a level surface. See the engine manufacturer's guidelines for engine shutdown time requirements prior to checking the oil level.

IMPORTANT: Use only approved engine lube oil. For lists of engine oils approved for Detroit Diesel engines, refer to the Engine Operator Manual, accessible on Lubricants, Fuels & Coolants on the DTNA Portal. For third party engines, please refer to the engine manual.

- 3.b If the oil level is at or below the minimum fill (or "add") mark on the dipstick, add enough oil to maintain the level between the minimum and maximum fill marks. See the engine operation manual for recommended lubricants.
4. Check the power steering reservoir fluid level.

The power steering fluid level should be between the MIN COLD mark and the middle mark just above it. See Fig. 412, [Power Steering Fluid Reservoir](#). If needed, fill the reservoir with automatic transmission fluid that meets Dexron III or TES-389 specifications.

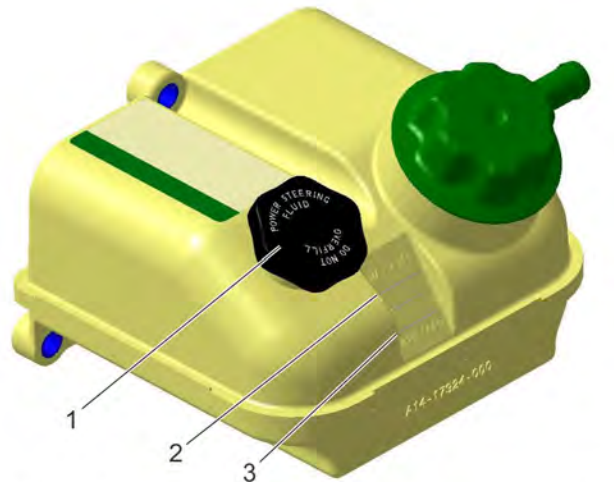

04/30/2020

f462252a

NOTE: Typical reservoir shown; configurations may vary.

1. Filler Cap
2. MAX Fill Line

3. COLD MIN Fill Line

Fig 412, Power Steering Fluid Reservoir

IMPORTANT: The surge tank must be cool to check the coolant level.



NOTICE:

Low coolant could result in engine overheating, which could cause engine damage.

5. Check the engine coolant level in the radiator surge tank. See Fig.413, [Coolant Surge Tank](#).

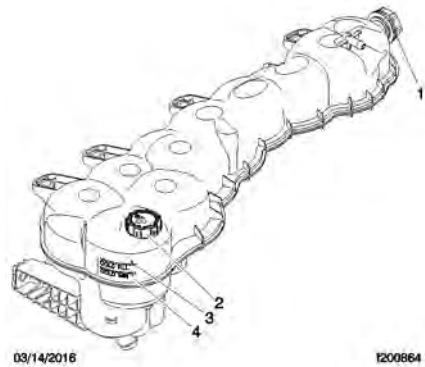

1. Pressure Relief Cap
2. Filler Cap

3. COLD MAX Fill Line
4. COLD MIN Fill Line

Fig 413, Coolant Surge Tank



NOTICE:

Coolant must be filled to the COLD MAX line of the surge tank. Low coolant could result in engine overheating, which could cause engine damage.

- 5.a If the coolant is low, fill the surge tank to the MAX line with a 50/50 mixture of water and the type of antifreeze currently installed in your vehicle.
- 5.b If the surge tank was empty, start the engine after refilling and check the level again when the engine is at operating temperature.
6. Inspect visible engine wiring for damage or looseness. Check for loose wiring, chafed insulation, and damaged or loose hold-down clamps.
7. Inspect visible frame rails for missing bolts, shiny areas, or rust streaks.

26.02.06 Inspection of the Cab

1. Push the reset button on the dash-mounted air intake restriction indicator, if equipped.
2. With the ignition switch in the OFF position, check the air-pressure warning system.

NOTE: The low-air warning buzzer only works when the park brake is released. The low-air warning buzzer is silenced when the park brake is set.

- 2.a If not previously drained, drain the air reservoirs using moderate brake applications until pressure in both reservoirs is less than 70 psi (483 kPa).
- 2.b Turn the ignition to the ON position. The ICU will complete a full gauge sweep and bulb check, and a low-air warning buzzer will sound. Ensure the low air pressure lamp (BRAKE AIR) remains illuminated and a low-air warning buzzer continues to sound after the gauge sweep is complete.
3. Check air governor cut-in and cut-out pressures.

- 3.a Start the engine and ensure the BRAKE AIR lamp goes out and the buzzer silences when pressure reaches approximately 70 psi (483 kPa) in both air reservoirs.
- The air governor should cut out at approximately 120 psi (827 kPa). For vehicles with an optional dryer reservoir module (DRM), the cut-out pressure is approximately 130 psi (896 kPa).
- 3.b With the engine idling, apply the brake pedal several times. The air governor should cut in when pressure in the primary air reservoir (top air gauge) reaches approximately 100 psi (689 kPa).
4. Check air pressure build-up time.
- 4.a With the air system fully charged, make one full brake application and note the air pressure reading on the primary air gauge.
- 4.b Further reduce air pressure using moderate brake applications, then run the engine at governed rpm.
- 4.c Note the time that the pressure reaches the previously noted reading on the primary air gauge, then note the time that the air pressure reaches cut-out pressure.
- 4.d If it takes longer than 30 seconds to reach cut-out pressure after the primary air gauge passes the previously noted pressure (noted after one full brake application), eliminate any leaks or replace the air compressor before operating the vehicle.
5. Check air leakage in the system.
- 5.a With the parking brake applied, the transmission out of gear, and the air system fully charged, release the service brakes and shut down the engine.
- 5.b Wait one minute and note the air pressure drop in psi (kPa) per minute from the primary air reservoir.
- If the pressure drop exceeds the limits shown in Table.49, [Maximum Allowable Air Leakage](#), eliminate any leaks before operating the vehicle.
6. Check the air pressure reserve.

With the engine still off, make one full brake application and observe the pressure drop on the primary air gauge. If pressure drops more than 25 psi (172 kPa), eliminate any leaks before operating the vehicle.

| Description | Pressure Drop: psi (kPa) Per Minute | |
|-----------------------------------|--|---------|
| | Released | Applied |
| Truck or Tractor Only | 2 (14) | 3 (21) |
| Truck or Tractor w/Single Trailer | 3 (21) | 4 (28) |
| Truck or Tractor w/Two Trailers | 5 (35) | 6 (42) |

Table 45, Maximum Allowable Air Leakage

**WARNING:**

When cleaning windshields and windows, always stand on the ground or on a secure ladder or platform. Use a long-handled window cleaner. Do not use the cab steps, tires, fenders, fuel tanks, engine, or under-hood components to access the windshield or windows. Doing so could cause a fall and result in an injury.

7. Inspect the mirrors, window glass, and windshield for cracks or other damage.
8. Ensure that the horn, windshield wipers, and windshield washers are operating properly. These devices must be in good working order for safe vehicle operation.
9. Ensure the heater and defroster are operating properly.
10. Check the operation of all interior lights.
 - 10.a Turn on the headlamps and leave them on. If equipped, ensure all gauge bulbs illuminate. If equipped, ensure ICU screens illuminate.
 - 10.b Ensure all equipped driver control switches illuminate and verify the interior cab lights controlled by these switches illuminate.
 - 10.c Ensure both turn signal indicators illuminate when the turn signal switch is activated.
11. Check the operation of all exterior lamps manually or, if equipped, by using either the LIGHT TEST switch on the dash or the Lamp Check button on the key fob.



10/25/2019

f546503a

- | | |
|-------------------------|---|
| 1. Clearance Lamp | 6. Headlamp, High Beam |
| 2. Identification Lamps | 7. Fog/Driving Lamp |
| 3. Turn Signal | 8. Side Marker Lamp |
| 4. DRL/Accent Lamps | 9. Stop Lamps, Tail Lamps, Turn Signals, and Back-Up Lamp |
| 5. Headlamp, Low Beam | |

Fig 414, Exterior Lights

12. To check exterior lamps manually:
 - 12.a Turn the ignition switch to the ACC or ON position.
 - 12.b Make certain the parking brake is set.
 - 12.c Activate the high-beam headlamps and hazard warning lamps.
 - 12.d Exit the cab and check that all exterior lamps and reflectors are clean and intact.
 - 12.e Check that the brake lamps, tail lamps, headlamps, turn signals, marker lamps, identification lamps, and clearance lamps are working properly.
13. To check the exterior lamps using the dash LIGHT TEST switch (see Fig.415, [Pretrip Light Test Switch](#)) or key fob Lamp Check button (see Fig.416, [Key Fob](#)):

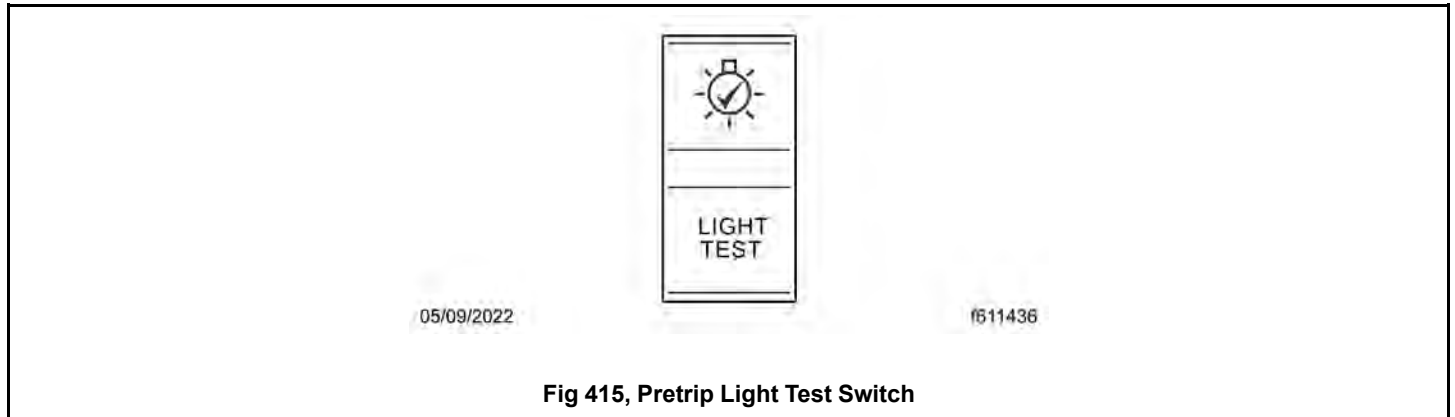

13.a Make sure the parking brake is set.

NOTE: Factory settings have groups of lamps activate sequentially up to 100 times or until manually stopped.

13.b Press either the LIGHT TEST switch or Lamp Check button to begin the pretrip light inspection. If equipped, groups of lamps will cycle on and off in the following sequence:

- Group 1: Always ON: marker lamps, clearance lamps, tail lamps, licence plate lamp
- Group 2: Low beam headlamps
- Group 3: High beam headlamps and stop lamps
- Group 4: Backup lamps and daytime running lamps
- Group 5: Front and rear fog lamps
- Group 6: Turn signals and utility lamps

NOTE: LED accent lighting turns off when the high beam headlamps turn on.

- 13.c Walk around the truck and check that the lamps are working properly.
- 13.d Verify that all exterior lights and reflectors are clean and intact.
- 13.e The pretrip light inspection can be stopped by:
 - releasing the parking brake;
 - Pressing either the LIGHT TEST switch on the dash or the Lamp Check button on the key fob.
- 14. Inspect the seat belts and tether belts.

**WARNING:**

Inspect and maintain seat belts. When any part of a seat belt system needs replacement, the entire seat belt must be replaced, both retractor and buckle side. Any time a vehicle is involved in an accident, and the seat belt system was in use, the entire vehicle seat belt system must be replaced before operating the vehicle. Do not attempt to modify the seat belt system; doing so could change the effectiveness of the system. Failure to replace worn or damaged seat belts, or making any modifications to the system, may result in personal injury or death.

- 14.a Check the web for fraying, cuts, extreme dirt and dust, or for severe fading from exposure to sunlight, especially near the buckle latch plate and in the D-loop guide area.
- 14.b Check operation of the buckle, latch, Komfort Latch or Sliding Komfort Latch (if equipped), web retractor, and upper seat belt mount on the door pillar. Check all visible components for wear or damage.
- 14.c Check the seat belt and tether belt connection points and tighten any that are loose.

**WARNING:**

Never fill fuel tanks to more than 95 percent of their liquid capacity. This could make them more likely to rupture from impact, possibly causing fire and resulting in serious personal injury or death by burning.

Do not mix gasoline or alcohol with diesel fuel. This mixture could cause an explosion, possibly resulting in serious personal injury or death. Do not fill the fuel tanks in the presence of sparks, open flames, or intense heat. These could ignite the fuel, possibly causing severe burns.

IMPORTANT: Use ultralow-sulfur diesel (ULSD) with 15 ppm sulfur content or less. Failure to use ULSD fuel may void the warranty on emission components.

- 15. Check the fuel level in the fuel tank(s). To keep condensation to a minimum, fuel tanks should be filled at the end of each day.
- 16. Adjust the rearview and down view mirrors as necessary.
- 17. Test the service brakes.
 - 17.a With the engine running and air system fully charged, set the parking brake.
 - 17.b Put the vehicle in the lowest gear and gently attempt to move it forward. The vehicle should not move.

If the vehicle moves, the parking brakes are not operating correctly and must be repaired before the vehicle is operated.

18. Test the backup alarm.
 - 18.a Release the parking brake and put the transmission in reverse.
 - 18.b Move the vehicle slightly backward to ensure that the backup alarm is operating correctly.

26.03 Weekly Post-Trip Inspections and Maintenance

26.03.01 Inspection of the Engine Compartment



WARNING:

Washer fluids may be flammable and poisonous. Do not expose washer fluid to an open flame or any burning material, such as a cigarette. Always comply with the washer fluid manufacturer's recommended safety precautions.

1. Check the windshield washer reservoir fluid level. The reservoir is usually located near the right-hand frame rail. See Fig. 417, [Windshield Washer Reservoir](#).

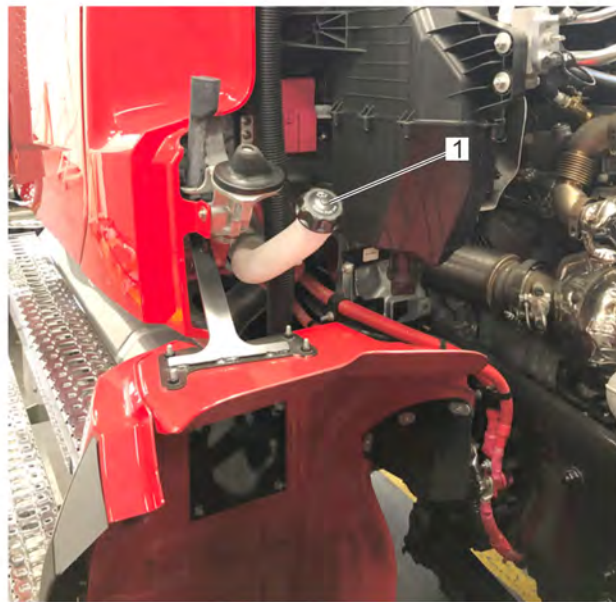

04/30/2020

f820442

1. Washer Fluid Filler Cap

Fig 417, Windshield Washer Reservoir

2. After resetting the air intake restriction indicator during the daily pretrip inspection, check the indicator again with the engine off.
 - 2.a Check an indicator with graduations to see if air restriction exceeds the value shown in Table 50, [Air Intake Maximum Restriction Values \(in H₂O\)](#).
Check a go/no-go indicator without graduations to see if the colored bar shows through the clear window.

| Engine Make | GHG14, GHG17, and GHG21 Engines |
|-------------|---------------------------------|
| Cummins | 25 |
| Detroit | 18 |

Table 46, Air Intake Maximum Restriction Values (in H₂O)

- 2.b If air restriction exceeds the maximum allowable value, operate the vehicle for one more day, making sure not to run the engine over rated rpm. Refer to the engine operation manual for more information on rated rpm for your engine.
- 2.c If air restriction exceeds the maximum value again, replace the air cleaner. For instructions, refer to **Group 09** of the **Workshop Manual**.
3. Inspect water evacuation components.
 - 3.a Inspect the vacuator valve(s) installed on the hood interior and air cleaner. Make sure the lips of each valve are undamaged and pliable, free of debris, and remain closed during inspection. See Fig. 418, [Hood Vacuator Valves \(hood interior shown\)](#).
 - 3.b Inspect the rain tray installed at the base of the windshield. Ensure that the seal on the forward edge of the rain tray is in good condition.
 - 3.c Inspect the drain hoses installed on the rain tray. Both hoses should be securely attached to the rain tray and direct water down the aft side of the front fenders.

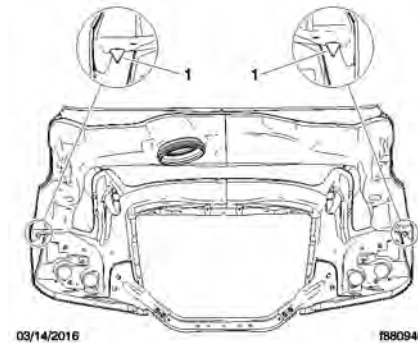

1. Vacuator Valves

Fig 418, Hood Vacuator Valves (hood interior shown)

4. If the vehicle is equipped with an Allison automatic transmission, check the automatic transmission fluid level.

IMPORTANT: When draining fluid from a fuel/water separator, drain the fluid into an appropriate container and dispose of it properly. Many jurisdictions now issue fines for draining fuel/water separators onto the ground.

5. Check for water in the fuel/water separator, if equipped.
 - 5.a Place a suitable container under the fuel/water separator.

NOTE: A hose may be used to direct water into the container. On older DAVCO models, the drain valve has a 1/2-inch (12.7-mm) pipe with threads. Use a hose with a 1/2-inch pipe thread to fit correctly and open the drain valve by turning it one-quarter revolution. On new DAVCO models, the drain valve has a 3/4-inch (19-mm) slip-on hose connection; pipe threads are no longer used. Open the drain valve by turning it one to one-and-a-half revolutions.

5.b If the engine is equipped with a built-in water separator, loosen the drain valve, and allow the water to run out. Close the drain valve, taking care not to overtighten it.

5.c **Detroit/Racor Models:** Turn the drain plug counterclockwise to open it.

DAVCO Models: Remove the vent cap and open the drain. See Fig. 419, [DAVCO Fuel Pro 485](#).

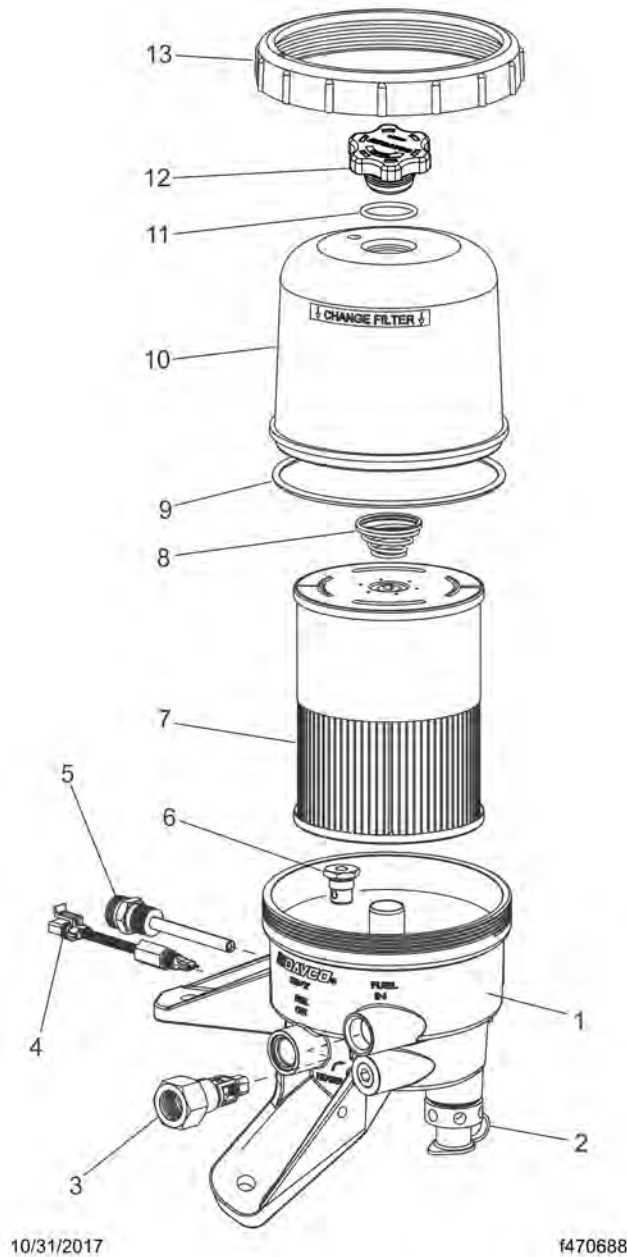

- | | |
|---------------------------|---------------------|
| 1. Lower Housing | 8. Spring |
| 2. Drain Valve | 9. Cover O-Ring |
| 3. Inlet Port/Check Valve | 10. Clear Cover |
| 4. 12VDC Pre-Heater | 11. Vent Cap O-Ring |
| 5. 120VAC Pre-Heater | 12. Vent Cap |
| 6. Bypass Valve | 13. Collar |
| 7. Filter Element | |

Fig 419, DAVCO Fuel Pro 485

5.d Stop draining fluid when fuel begins to drain out.

Detroit/Racor Models: turn the drain plug clockwise to close it.

DAVCO Models: close the drain valve. Install and hand-tighten the vent cap.

6. Inspect the steering components.

- 6.a Inspect tie rods, steering arms, and the drag link for signs of looseness (i.e., shiny spots or rust tracks).
- 6.b Check the steering gear mounting bolts and pitman arm nut, if equipped, for signs of looseness. See Fig. 420, [Steering Gear Fasteners](#).
- 6.c Check the drag link nuts for missing cotter pins.

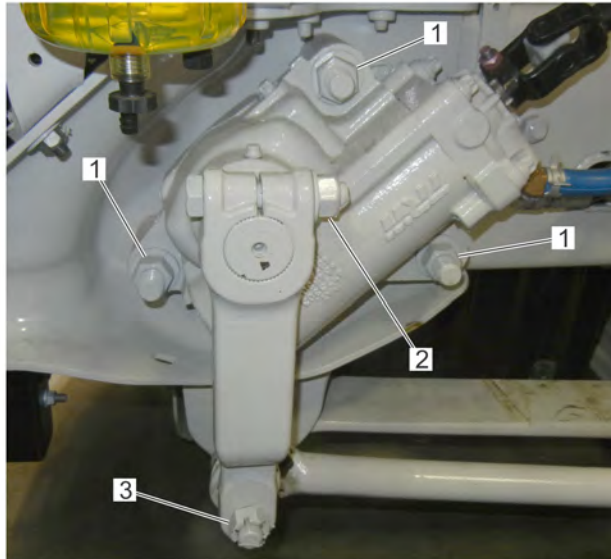

10/03/2016

f462304

1. Steering Gear Mounting Bolts
2. Pitman Arm Pinch Bolt Nut
3. Drag Link Nut

Fig 420, Steering Gear Fasteners

- 6.d Inspect the steering intermediate shaft and end yokes for excessive looseness or other damage.



NOTICE:

Do not drive with a drive belt that is visibly worn or damaged. If it fails, the lack of coolant flow could rapidly cause damage to engine components.

7. Inspect the serpentine drive belts for signs of glazing, frayed edges, breaks, cracks, or oil contamination.

26.04 Monthly Post-Trip Inspections and Maintenance

26.04.01 Inspection of the Brake Component

Walk around the vehicle and inspect brake system components for visible damage.

NOTE: Some vehicles may be equipped with a brake check valve on the dash, which allows the driver to set the service brakes and exit the vehicle to check the brake system for leaks. The parking brakes must be applied before the brake check valve will function.

1. Inspect all visible brake system components for missing fasteners or signs of looseness, such as rust tracks.

**NOTICE:**

If the external breather tube or breather cap is missing or incorrectly installed, road dirt and debris can adversely affect the operation of the brake chamber. Once inside of the chamber, dirt and debris can cause the internal parts of the chamber to deteriorate faster.

2. Inspect the exterior surfaces of brake chambers for damage. Make sure that breather holes are open and free of debris.

NOTE: Do not route air brake lines on top of anything likely to be stepped on.

3. Inspect air brake lines for dents, swelling, kinks, twisting, abrasion, and damage, especially near moving parts.
4. Inspect flex air lines for deterioration or signs of abrasion.
5. Inspect for cracked, worn, or oil-contaminated brake linings and brake drums (or rotors).
6. Check the thickness of the brake linings. Replace brake linings on all brake assemblies on the axle if any brake linings are worn to less than approximately 1/4 inch (6.4 mm) at the thinnest point.

26.04.02 Inspection of the Saddle Tank Areas

**WARNING:**

When draining the air reservoir, do not look into the air jets or direct them toward anyone. Dirt or sludge particles may be in the airstream and could cause injury.

**NOTICE:**

If the water drained from the air reservoirs is cloudy or oily, it may indicate a problem with the compressor. If oil is allowed to contaminate the air dryer, it will not remove the water from the air brake system, which could adversely affect braking.

1. Drain the brake system air reservoirs (reservoirs with automatic drain valves only).

NOTE: Battery locations vary between vehicles.

2. Inspect the batteries.

**WARNING:**

Battery posts, terminals, and related accessories contain lead and lead compounds, chemicals known to the State of California to cause cancer and reproductive harm. To prevent possible personal injury, always wash your hands after handling battery parts and related accessories.

- 2.a Remove the battery box cover and inspect all visible battery cables for loose wiring or damage.
- 2.b Check that the battery hold-down is secure.

IMPORTANT: Aerodynamic components decrease drag force as a vehicle moves, thereby improving fuel efficiency. If replacement of an aerodynamic component is necessary, replacement components must meet or exceed the drag reduction performance of the originally installed component in order to maintain compliance with greenhouse gas and fuel efficiency regulations.

3. Inspect the following aerodynamic components, if equipped, for structural damage, cracks, or wear.
 - Chassis fairings
 - Roof fairing/deflector
 - Side skirts
 - Cab/sleeper extenders
 - Battery access cover

26.04.03 Inspection and Adjustments of the Engine Compartment

IMPORTANT: If replacement of the hood or bumper is necessary, the replacement component must meet or exceed the drag reduction performance of the originally installed item in order to maintain compliance with greenhouse gas and fuel efficiency regulations.

NOTE: Anytime a hood is adjusted, removed, or reinstalled, the headlamp aim should be checked.

1. Inspect the bumper and hood for structural damage, cracks, or wear.
2. Check the hydraulic clutch reservoir, if equipped. If necessary, add DOT 4 brake fluid.
3. Inspect the radiator and heater hoses, including the clamps and support brackets.
 - 3.a Inspect the radiator and charge air cooler for damage and accumulated debris. Straighten bent or damaged fins to permit airflow across all areas of the cores.

NOTE: When traveling through areas of high insect concentration, it may be necessary to clean the exterior of the radiator or the charge air cooler core as often as every 200 miles (320 km).

- 3.b Make sure the radiator inlet and outlet hoses are pliable and are not cracking or ballooning.
- 3.c Make sure the heater hoses are pliable and are not cracking or ballooning.

- 3.d Tighten hose clamps as necessary.

IMPORTANT: Do not overtighten hose clamps, as hose life can be adversely affected.

- 3.e Ensure hose support brackets are securely fastened. Make sure hoses are not located near sources of wear, abrasion, or high heat.

IMPORTANT: When replacing hoses, install service-type knitted or braided yarn-reinforced neoprene hose. Extended-service-life silicone hoses may also be used. See the Alliance Parts Catalog at www.alliancebrandparts.com or contact your Freightliner Dealer.

4. Check the steering wheel for excessive play.
 - 4.a Start the engine. With the front tires straight ahead, turn the steering wheel until motion is observed at the front wheels.
 - 4.b Align a reference mark on the steering wheel to a rule, then slowly turn the steering wheel in the opposite direction until motion is again detected at the wheels.
 - 4.c Measure the lash (free play) at the rim of the steering wheel. Excessive lash exists if steering wheel movement exceeds 2-1/4 inches (57 mm) with an 18-inch (450-mm) steering wheel.
 - 4.d If there is excessive lash, check the steering system for wear or incorrect adjustment before operating the vehicle.

| | |
|--|-----|
| 27.01 Hazard Warning Lights | 516 |
| 27.02 Fire Extinguisher | 516 |
| 27.03 Fire in the Cab | 516 |
| 27.04 Emergency Equipment | 516 |
| 27.05 Emergency Starting With Jumper Cables | 517 |
| 27.06 Raising and Lowering a Vehicle | 519 |
| 27.06.01 Raising a Vehicle with Air Suspension | 519 |
| 27.06.02 Lowering a Vehicle with Air Suspension | 520 |
| 27.06.03 Raising a Vehicle without Air Suspension | 520 |
| 27.06.04 Lowering a Vehicle without Air Suspension | 521 |
| 27.07 Front Towing Hookup With Removable Tow Hooks | 521 |
| 27.07.01 Use of Tow Hooks | 521 |

27. In An Emergency

27.01 Hazard Warning Lights

The hazard warning light switch is located on the dash in what is referred to as the main module. See Fig. 421, [Hazard Warning Switch](#). The hazard lights can be activated regardless of the ignition switch position.

To activate the hazard lights, push the center of the switch once. The switch will blink at the same rate that the hazard lights flash. Push the switch again to turn them off. All the turn signal lights on the vehicle and trailer, as well as the turn signal indicators in the ICU, flash simultaneously when the hazard lights are activated.



Fig 421, Hazard Warning Switch

27.02 Fire Extinguisher

An optional factory-installed fire extinguisher may be located in the cab, usually by the driver's door, or in the sleeper baggage compartment.

27.03 Fire in the Cab

The incidence of fire in heavy- and medium-duty trucks is rare, according to data from the National Highway Traffic Safety Administration. Federal Motor Vehicle Safety Standard #302 limits the flammability of specified materials used inside the cab, but despite this, most materials can burn.



WARNING:

Do not allow flames, sparks, or any other heat sources (such as cigarettes or light bulbs) to contact materials in the cab. Any materials in the cab in contact with these heat sources could cause serious personal injury or vehicle damage.

In Case of a Cab Fire

As quickly as possible, bring the vehicle to a safe stop, apply the parking brake, turn off the ignition, and get out of the vehicle.

27.04 Emergency Equipment

Emergency equipment and tools may be supplied in the cab or sleeper baggage compartment. The equipment may include: a first aid kit, triangular reflectors, flares, tire-changing equipment, and tools.

**WARNING:**

Use extreme care when placing flares in emergency situations that involve exposure to flammable substances such as fuel. An explosion or fire could occur causing serious personal injury.

If there is an emergency while driving, cautiously pull off the road. Turn on the hazard warning lights. Place the flares and reflector along the side of the road to alert other drivers that an emergency situation exists.

27.05 Emergency Starting With Jumper Cables

When using jumper cables, follow the instructions below.

**WARNING:**

Batteries release explosive gas. Do not smoke when working around batteries. Put out all flames and remove all sources of sparks or intense heat in the vicinity of the battery. Do not allow the vehicles to touch each other. Do not lean over the batteries when making connections, and keep all other persons away from the batteries. Failure to follow these precautions could lead to severe personal injury as a result of an explosion or acid burns.

**NOTICE:**

Make sure both electrical systems are the same voltage. Electronic devices on both vehicles can be damaged when connected to a vehicle with a different operating voltage.

NOTE: On vehicles equipped with optional underhood jump start posts, connect to these posts instead of the batteries.

1. Apply the parking brakes and turn off the lights and all other electrical devices.
2. Remove the battery box cover.

NOTE: The battery box may be located in a variety of locations, including under the passenger seat, behind the side fairing, or behind the cab. If the battery box is located behind the side fairing, it can be accessed by opening the side fairing kick panel.

3. Connect the positive (+) jumper cable to the positive battery post or jump start post on the vehicle needing the jump start. See callout A in Fig.422, [Jumper Connections on Vehicle Needing Jump Start](#).

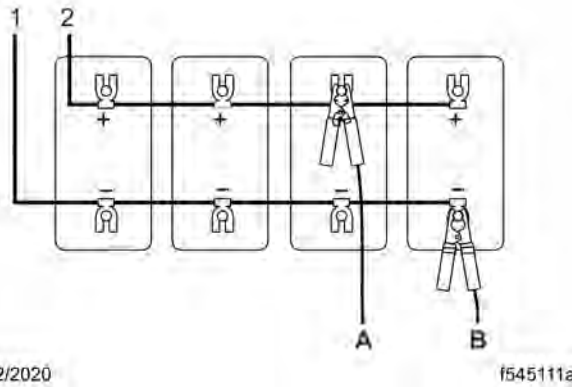

- | | |
|---|--|
| 1. – Hardline Battery Cable of Vehicle Needing the Jump | 3. + Jumper Cable to Connect First and Disconnect Last |
| 2. + Hardline Battery Cable of Vehicle Needing the Jump | 4. – Jumper Cable to Connect Last and Disconnect First |

Fig 422, Jumper Connections on Vehicle Needing Jump Start

- Then connect the other end of the positive jumper cable to the positive battery or jump start post of the vehicle providing the jump start.



WARNING:

Do the next step exactly as instructed and do not allow the clamps of one cable to touch the clamps of the other cable. Otherwise, a spark could occur near a battery, possibly resulting in severe personal injury from explosion or acid burns.

- Connect one end of the negative jumper cable to the negative battery or jump start post of the vehicle providing the jump start.
- Then connect (ground) the other end of the cable to a negative battery or jump start post on the vehicle needing a jump start. See callout B in Fig.422, [Jumper Connections on Vehicle Needing Jump Start](#).
- Start the engine of the vehicle providing the jump start and let the engine run a few minutes to charge the batteries of the other vehicle.
- Attempt to start the engine of the vehicle with the batteries receiving the charge. Do not operate the starter longer than 30 seconds, and wait at least two minutes between starting attempts to allow the starter to cool.
- When the engine starts, let it idle a few minutes.



WARNING:

Do the next step exactly as instructed and do not allow the clamps of one cable to touch the clamps of the other cable. Otherwise, a spark could occur near a battery, possibly resulting in severe personal injury from explosion or acid burns.

- Disconnect the negative (grounded) jumper cable from the vehicle that needed the jump start. See callout B in Fig. 422, [Jumper Connections on Vehicle Needing Jump Start](#).

11. Then disconnect the other end of the jumper cable from the vehicle that provided the jump start.
12. Disconnect the positive jumper cable from the positive battery or jump start post of the vehicle that provided the jump start.
13. Then disconnect the other end of the positive jumper cable from the positive battery or jump start post of the vehicle that received the jump start. See callout A in Fig.422, [Jumper Connections on Vehicle Needing Jump Start](#).
14. Install the battery box cover; be sure it is positioned properly before fastening the latches.

27.06 Raising and Lowering a Vehicle

27.06.01 Raising a Vehicle with Air Suspension

1. Park the vehicle on a level surface, set the parking brakes, and shut down the engine. Chock the tires.

**WARNING:**

Remove the air from the suspension. Failure to remove the air from the suspension may cause the vehicle to move or shift on the jack stands as air pressure drains from the system; this could cause the vehicle to fall, resulting in damage to the vehicle, serious injury, or death.

2. Exhaust all air from the air suspension.

**WARNING:**

Do not use bottle jacks to raise the vehicle. Always use floor jacks. Bottle jacks can slip, allowing the vehicle to fall, which could result in damage to the vehicle, serious injury, or death.

IMPORTANT: Only lift unloaded vehicles and vehicles disconnected from trailers. Unload vehicles with bodies (drilling rigs, mixers) as much as possible.

3. Place a floor jack under the axle housing, the clamp group, or the frame rail.

**NOTICE:**

Do not place jack stands under any of the suspension components; doing so could cause suspension component damage. Jack stands can be placed at any point below the axle, including the differential area.

4. Raise the vehicle. Add additional jack stands, as needed, under the axles to support the vehicle.

27.06.02 Lowering a Vehicle with Air Suspension

**WARNING:**

Do not use bottle jacks to raise the vehicle. Always use floor jacks. Bottle jacks can slip, allowing the vehicle to fall, which could result in damage to the vehicle, serious injury, or death.

**NOTICE:**

Do not place jack stands under any of the suspension components; doing so could cause suspension component damage. Jack stands can be placed at any point below the axle, including the differential area.

1. Using the floor jack, raise the vehicle to remove any jack stands used to support the vehicle.
2. Slowly lower the vehicle to the ground.
3. Inflate the air suspension, and check for proper operation. Refer to **Group 32** in the **Workshop Manual** for instructions.

27.06.03 Raising a Vehicle without Air Suspension

1. Park the vehicle on a level surface, set the parking brakes, and shut down the engine. Chock the tires.

**WARNING:**

Do not use bottle jacks to raise the vehicle. Always use floor jacks. Bottle jacks can slip, allowing the vehicle to fall, which could result in damage to the vehicle, serious injury, or death.

IMPORTANT: Only lift unloaded vehicles and vehicles disconnected from trailers. Unload vehicles with bodies (drilling rigs, mixers) as much as possible.

2. Place a floor jack under the axle housing, the clamp group, or the frame rail.

**NOTICE:**

Do not place jack stands under any of the suspension components; doing so could cause suspension component damage. Jack stands can be placed at any point below the axle, including the differential area.

3. Raise the vehicle. Add additional jack stands, as needed, to support the vehicle.

27.06.04 Lowering a Vehicle without Air Suspension

**WARNING:**

Do not use bottle jacks to raise the vehicle. Always use floor jacks. Bottle jacks can slip, allowing the vehicle to fall, which could result in damage to the vehicle, serious injury, or death.

**NOTICE:**

Do not place jack stands under any of the suspension components; doing so could cause suspension component damage. Jack stands can be placed at any point below the axle, including the differential area.

1. Using the floor jack, raise the vehicle to remove any jack stands used to support the vehicle.
2. Slowly lower the vehicle to the ground.

27.07 Front Towing Hookup With Removable Tow Hooks

27.07.01 Use of Tow Hooks

**NOTICE:**

Towing the truck from the front and removing all of the drivelines is the approved method for towing DTNA products. Towing any other way is not preferred.

**DANGER:**

When working on the vehicle, shut down the engine, set the parking brake, and chock the tires. Before working under the vehicle, always place jack stands under the frame rails to ensure the vehicle can not drop. Failure to follow these steps could result in serious personal injury or death.

**WARNING:**

Do not tow an unbraked vehicle if the combined weight of both vehicles is more than the sum of the gross axle weight ratings (GAWR) of the towing vehicle. Otherwise brake capacity will be inadequate, which could result in personal injury or death.

Tow hooks are not designed for on-road towing of the vehicle, but to recover and move the vehicle to a position where it can be hooked up properly for front towing.

**NOTICE:**

When using tow hooks to move the vehicle, do not pass a sling (for example, a rope or chain) from one hook to another. Known as reeving, this practice is **not** permissible in most industrial applications of towing and hoisting. Reeving can overload the hooks and result in damage to the vehicle. See Fig.423,, page 523.

Do not reeve when towing.

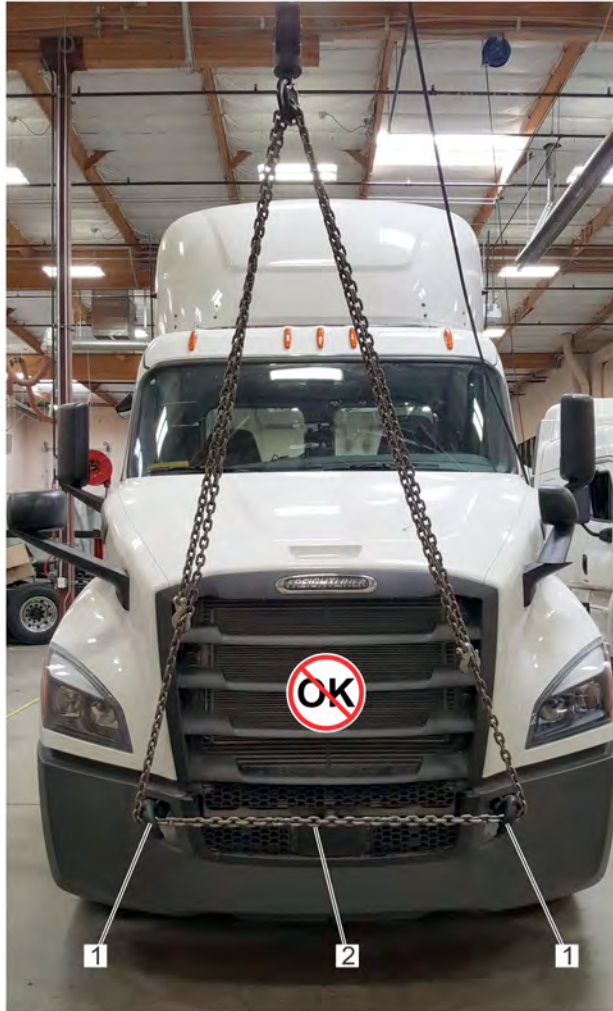

09/21/2017

f311215

1. Tow Hook

2. Chain

Fig 423, Reeving

Do not reeve when towing.

1. Disconnect the battery ground cables.



NOTICE:

Failure to protect the frame rails from the chains could cause damage, leading to eventual frame failure.

2. On dual drive axles, if the vehicle is to be lifted and towed, chain the forward rear-axle assembly to the vehicle frame. Use protection to keep the chains from damaging the frame.

3. Open the hood. Remove the tow hooks, located behind the driver's-side bumper. See Fig.424, [Tow Hooks](#). Close and latch the hood.

**NOTICE:**

New or ungreased tow hooks may be hard to install. Tow hooks that are not properly installed may be damaged or break.

4. Install the tow hooks onto the tow hook receivers through the tow hook holes in the bumper, rotating the hooks so the hook opening faces down. See Fig.425, [Tow Hooks Installed, Facing Down](#). Pull the tow hooks to ensure they are securely engaged in the tow hook receivers.

**Fig 424, Tow Hooks****Fig 425, Tow Hooks Installed, Facing Down**

5. Lower the stinger assembly so that it is level and approximately 1 inch (0.3 cm) off the ground. Back the tow truck so that the crossbar with lift adaptors is within 6 inches (15 cm) of the Aero bumper. See Fig. 426, [Positioning the Stinger Assembly](#).



Fig 426, Positioning the Stinger Assembly



NOTICE:

When using tow hooks to move the vehicle, do not pass a sling (for example, a rope or chain) from one hook to another. Known as reeving, this practice is **not** permissible in most industrial applications of towing and hoisting. Reeving can overload the hooks and result in damage to the vehicle.

6. Pull the tow cables out of the tow truck and connect the tow cable lifting hooks onto the tow hooks, then extend the recovery boom within 4 to 6 inches (10 to 15 cm) of being vertical of the tow hooks. See Fig. 427, [Tow Cables Connected to the Tow Hooks](#).
7. Lift the front of the truck until there is enough clearance for the stinger and crossbar to pass under the bumper. See Fig. 428, [Moving the Stinger and Crossbar Under the Bumper](#).

If enough clearance cannot be gained with a single lift, jack stands or other means capable of supporting the weight on the front axle must be used while the cables are shortened to allow a second lift.



06/14/2017

f130150

Fig 427, Tow Cables Connected to the Tow Hooks

06/14/2017

f130151

Fig 428, Moving the Stinger and Crossbar Under the Bumper**WARNING:**

Failure to chock the tires or connect the tow truck's air brake system before releasing the spring parking brakes could allow the disabled vehicle to suddenly roll. This could cause property damage or personal injury.

8. Chock the rear tires.

**NOTICE:**

Reference the applicable axle manufacturer's information to avoid damaging the axle when towing the truck.

9. Use mid-rise or high-rise forks, or lift adaptors (part number 0200020) on the crossbar to provide clearance for the aerodynamic bumper. See Fig. 429, [Lift Adaptors Installed on the Crossbar](#) and Fig. 430, [Backing the Tow Truck with Lift Adaptors on the Crossbar](#).



06/14/2017

f130152

Fig 429, Lift Adaptors Installed on the Crossbar

06/14/2017

f130153

Fig 430, Backing the Tow Truck with Lift Adaptors on the Crossbar

10. Extend the stinger and place the lift adaptors under the axle. Make certain the lift adaptors are under the front suspension springs between the U-bolts. See Fig. 431, [Positioning the Stinger with Lift Adaptors Under the Axle](#) and Fig..

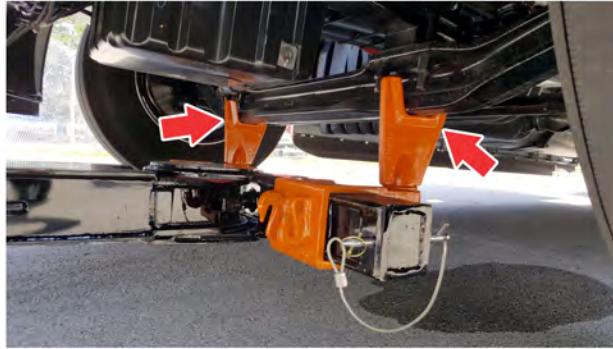

06/14/2017

f130154

Fig 431, Positioning the Stinger with Lift Adaptors Under the Axle



06/14/2017

f130155

Fig 432, Stinger with Lift Adaptors Under the Axle (tow truck shown)

11. Secure the axle to the crossbar with a chain or ratchet strap.



NOTICE:

Failure to remove the driveline(s) or the drive axle shafts when towing the vehicle with the rear wheels on the ground could result in damage to the transmission and other parts.

12. Use a paint pen to mark the drivelines in as built condition, and then remove the driveline, the interaxle driveline (if equipped), for each axle that may touch the ground during the towing process. Store the drivelines and U-joints in a secure location so they will not come off during transport.
13. Remove the tow cables from the tow hooks and retract the recovery boom. See Fig. 433, [Retracting the Recovery Boom](#).



Fig 433, Retracting the Recovery Boom

14. Remove the tow hooks from the bumper.

IMPORTANT: On trucks equipped with a front air suspension, either air pressure must be supplied to the secondary air system or the front suspension must be blocked to operating height with wooden spacers and the axle chained to the frame to prevent damage to the truck.

15. Connect the air and electrical supply lines from the tow truck to the truck being towed.
16. Connect the clearance lights, taillights, and signal lights. Connect any special towing lights required by local regulations.
17. Release the park brake and remove the chocks from the rear tires.
18. Use the stinger to pull the truck close to the back of the tow truck for final towing position. See Fig. 434, [Final Towing Position](#).



Fig 434, Final Towing Position

19. Connect the safety chains. See Fig.435, [Safety Chains Connected on the Towed Vehicle](#).



06/14/2017

f130158

Fig 435, Safety Chains Connected on the Towed Vehicle

| | |
|--|-----|
| 28.01 Telematics Information: Terms of Use..... | 532 |
| 28.01.01 Telematics Information We Collect and Why We Collect It | 532 |
| 28.01.02 What We Do with Telematics Information and Who We Share It With | 533 |
| 28.01.03 Collection Method | 533 |
| 28.01.04 Safeguards..... | 533 |
| 28.01.05 Your Consent..... | 533 |
| 28.01.06 Your Rights..... | 534 |
| 28.01.07 Privacy Statement Changes..... | 534 |
| 28.02 Frequency Bands and Maximum Transmission Output..... | 534 |
| 28.02.01 Wireless Applications on the Vehicle..... | 534 |
| 28.02.02 The Common Telematics Platform..... | 535 |

28. Telematics Data

28.01 Telematics Information: Terms of Use

28.01.01 Telematics Information We Collect and Why We Collect It

Your vehicle ("Vehicle") may be equipped with one or more devices that gather information described below regarding the Vehicle and the environment in which it may be operating ("Telematics Information"). The devices may periodically send Telematics Information to Daimler Truck North America LLC ("DTNA"). Additionally, DTNA and its dealers may manually retrieve Telematics Information from the devices for the purposes described below.

The Telematics Information we collect may include, but is not limited to, the following information about the Vehicle:

- performance
- operation
- location
- speed
- trips
- travel history
- stop and idle times
- fuel consumption
- fault codes
- diagnostic information
- steering performance
- braking performance
- air bag deployment
- seatbelt use
- decelerations
- other information relating to the performance, operation, health and safety of the Vehicle.

DTNA gathers this information to improve the performance, operation, health and safety of your Vehicle and other DTNA vehicles and products. Information is gathered:

- **To enable your subscription services.** DTNA and other third party service providers have developed a variety of applications and services that are now available to you to optimize the performance, use, reliability and safe operation of your Vehicle. These services are enabled by the Telematics Information we receive from your Vehicle and will likely be made more effective in the future by the use of that Telematics Information and similar information we receive from other DTNA vehicles.
- **To make your Vehicle safer and to improve its performance.** Depending on the type of device installed on your Vehicle, DTNA may periodically update your Vehicle's on-board software to improve the performance and safe use of the Vehicle. We may need to obtain certain Telematics Information to ensure the effectiveness of these updates.
- **To monitor and manage the health and efficiency of your Vehicle.** Telematics Information from your Vehicle may be used by DTNA and its affiliates, dealers and service providers to diagnose and resolve problems with your Vehicle more effectively and to help you maintain it.
- **To improve your customer service experience.** Telematics Information may be used by DTNA and its affiliates, dealers and service providers to provide you a more efficient and effective customer service experience in conjunction with Vehicle service, maintenance, field service campaigns and recalls.

- **For product development and product improvement.** Telematics Information may be analyzed and used to identify and resolve performance and safety issues and to develop improvements to our products that will benefit you and our future customers.
- **To develop more meaningful product marketing.** Telematics Information may be used to provide more customized and meaningful information to our customers regarding products and services that best satisfy their operational requirements and improve the performance of their businesses.
- **To help match our customers with the right products.** Telematics Information may be used to develop future products and services that best satisfy the operational requirements of our customers.

28.01.02 What We Do with Telematics Information and Who We Share It With

Your vehicle ("Vehicle") may be equipped with one or more devices that gather information described below regarding the Vehicle and the environment in which it may be operating ("Telematics Information"). The devices may periodically send Telematics Information to Daimler Truck North America LLC ("DTNA"). Additionally, DTNA and its dealers may manually retrieve Telematics Information from the devices for the purposes described below.

DTNA may use Telematics Information for any purpose allowed by law, including but not limited to using the information for any of the purposes described in this chapter. DTNA may share Telematics Information with its service providers, affiliates, subsidiaries, dealers and distributors, but only for lawful business purposes. This may include third parties who process information on behalf of DTNA, third parties who you authorize directly to receive information from us, and law enforcement agencies pursuant to applicable law.

DTNA may also combine Telematics Information it obtains from your Vehicle with data from others, anonymize and de-identify that aggregated data ("Aggregated Data"), and use and disclose that Aggregated Data and derivatives of it indefinitely and for any purpose whatsoever, including sharing it with third parties for any purpose without restriction. You will not have any rights in any Aggregated Data or any derivatives or proceeds of it. DTNA will be the exclusive owner of all rights, title and interests in and to all Aggregated Data. DTNA shall not have any obligation to provide any Aggregated Data to you or to compensate you for any use or disclosure of any Aggregated Data.

28.01.03 Collection Method

Your vehicle ("Vehicle") may be equipped with one or more devices that gather information described below regarding the Vehicle and the environment in which it may be operating ("Telematics Information"). The devices may periodically send Telematics Information to Daimler Truck North America LLC ("DTNA"). Additionally, DTNA and its dealers may manually retrieve Telematics Information from the devices for the purposes described below.

The Telematics Information may be transmitted automatically or manually from the devices on your Vehicle to DTNA or Detroit Diesel Corporation (DDC) through diagnostic tools, including but not limited to DDC DiagnosticLink.

28.01.04 Safeguards

Your vehicle ("Vehicle") may be equipped with one or more devices that gather information described below regarding the Vehicle and the environment in which it may be operating ("Telematics Information"). The devices may periodically send Telematics Information to Daimler Truck North America LLC ("DTNA"). Additionally, DTNA and its dealers may manually retrieve Telematics Information from the devices for the purposes described below.

DTNA will use reasonable data security systems and procedures in an effort to protect Telematics Information from unauthorized use, access, disclosure, distribution, loss or alteration. We do this through physical, electronic and procedural safeguards that are designed to protect the confidentiality, integrity and availability of Telematics Information. However, no security system is perfect. DTNA cannot guarantee that Telematics Information will not be hacked, deleted, intercepted or altered.

DTNA will also require other parties to whom Telematics Information is disclosed to take reasonable steps to protect the Telematics Information from unauthorized use, access, disclosure, distribution, loss or alteration.

28.01.05 Your Consent

Your vehicle ("Vehicle") may be equipped with one or more devices that gather information described below regarding the Vehicle and the environment in which it may be operating ("Telematics Information"). The devices may periodically send Telematics Information to Daimler Truck North America LLC ("DTNA"). Additionally, DTNA and its dealers may manually retrieve Telematics Information from the devices for the purposes described below.

By continuing to provide to us, or allowing us to receive or retrieve, Telematics Information through the devices on your Vehicle, you consent to its collection and use as described in this chapter.

Although some information may be transferred to and processed in countries without laws providing the same level of data protection as your country, our use and disclosure of your information is subject to these terms of use regardless of where your information is transferred.

If you have subscribed to a subscription service such as Virtual Technician or Detroit Analytics, the Telematics Terms and Conditions for that service will apply to DTNA's collection, storage, use and sharing of the data covered by those Terms and Conditions.

28.01.06 Your Rights

Your vehicle ("Vehicle") may be equipped with one or more devices that gather information described below regarding the Vehicle and the environment in which it may be operating ("Telematics Information"). The devices may periodically send Telematics Information to Daimler Truck North America LLC ("DTNA"). Additionally, DTNA and its dealers may manually retrieve Telematics Information from the devices for the purposes described below.

You may ask DTNA to discontinue receiving and retrieving Telematics Information from the devices on your Vehicle. If you do so, you will be unable to receive telematics subscription services relating to your Vehicle and unable to remotely receive important Vehicle software updates, among other things. If you are interested in that option, please contact DTNA at: **DetroitConnect@Daimler.com**.

28.01.07 Privacy Statement Changes

Your vehicle ("Vehicle") may be equipped with one or more devices that gather information described below regarding the Vehicle and the environment in which it may be operating ("Telematics Information"). The devices may periodically send Telematics Information to Daimler Truck North America LLC ("DTNA"). Additionally, DTNA and its dealers may manually retrieve Telematics Information from the devices for the purposes described below.

DTNA reserves the right to amend these terms of use from time to time. Changes will be reflected in the online version of this document, which can also be found at: <https://www.dtnatechlit.com/portal-public>. **By continuing to provide to us, or allowing us to receive or retrieve, Telematics Information through the devices on your Vehicle, you consent to and accept those changes.**

NOTE: These terms of use do not apply to aftermarket telematics devices that may be provided by others or configured to send information to someone other than DTNA or its affiliates, dealers or service providers.

28.02 Frequency Bands and Maximum Transmission Output

28.02.01 Wireless Applications on the Vehicle

| Component | Service | Frequency Band | Transmission Output |
|-------------|------------------------|---|------------------------|
| CTP2019DTNA | 4G LTE | LTE FDD Band 2 LTE FDD Band 4 LTE FDD Band 5 LTE FDD Band 7 LTE FDD Band 17 | 0.25 W (Power Class 3) |
| | 3G UMTS/HSDPA/HSUPA | UMTS Band 1 UMTS Band 2 UMTS Band 4 UMTS Band 5 UMTS Band 8 | 0.25 W (Power Class 3) |

Table 51, Frequency Bands and Maximum Transmission Output

| Component | Service | Frequency Band | Transmission Output |
|-----------|-----------------------|------------------------------|---------------------|
| | 2G GSM/GPRS/EDGE | GSM 850 MHz E-GSM 900 MHz | 2 W (Power Class 4) |
| | | DCS 1800 MHz PCS 1900 MHz | 1 W (Power Class 1) |
| | WLAN (IEEE 802.11b) | 2.4 GHz band | 20 mW |
| | WLAN (IEEE 802.11g/n) | 2.4 GHz band | 20 mW |
| | Bluetooth | 2.4 GHz band | 10 mW |
| | GPS / GLONASS | 1575 and 1602 MHz | Receive only |

Table 47, Frequency Bands and Maximum Transmission Output

28.02.02 The Common Telematics Platform

The Detroit Connect Platform is the connectivity module of Daimler Truck North America. It receives and transmits data in real time and is the interface for all connectivity-related services. Both the Detroit Connect Platform and a valid agreement is required for use of the Detroit Connect services.

Vehicle antennas (WLAN/BT/CellularNetworks) are located inside and behind the dashboard on the passenger side. In both locations, the shortest possible distance between the antennas and any human or animal body part inside the vehicle cabin is greater than 8 in (20 cm).

Therefore Daimler Truck North America LLC declares that the radio equipment type CTP2019DTNA is in compliance with Directive 2014/53/EU.



CONTACT INFORMATION

For questions, please create a Service Technical Request using the DTTS Application on the DTNA Portal.