



Business Class M2 Plus Driver's Manual

Models: M2 Plus

Table of Contents

1. Foreword.....	5
2. Vehicle Identification	9
3. Vehicle Access	23
4. Instruments	35
5. Driver Controls	101
6. Cab Features.....	121
7. Detroit Assurance 5.0.....	151
8. Driver Assistance Features	187
9. Electrical System	203
10. Engine Starting, Operation, and Shutdown.....	215
11. Optional Engine Systems.....	223
12. Brake Systems	231
13. Steering System	253
14. Emissions.....	257
15. Automated and Automatic Transmissions	271
16. Manual Transmissions, Clutch, and Transfer Cases.....	309
17. Drive Axles	321
18. Fifth Wheels and Trailer Couplings	333
19. Headlight Aiming.....	363
20. Natural Gas Vehicle Information	369
21. Vehicle Appearance and Care.....	385
22. Pre- and Post-Trip Checklists.....	393
23. Pre- and Post-Trip Inspections and Maintenance.....	399
24. In an Emergency.....	421
25. Telematics Data	439

1.01 Customer Assistance Center.....6

1.02 Environmental Concerns and Recommendations6

1.03 Data Logging6

1.04 Emissions and Fuel Efficiency Compliance.....6

1.05 Reporting Safety Defects6

1. Foreword

1.01 Customer Assistance Center

Having trouble finding service? Call the Customer Assistance Center at 1-800-385-4357 or 1-800-FTL-HELP. For dealer referrals and breakdown support, call night or day, weekdays or weekends. For specification requests and all other concerns and inquiries, the Customer Assistance Center is available 5:00 A.M. to 4:00 P.M. PST Monday through Friday. Our people are knowledgeable, professional, and committed to following through to help you keep your truck moving.

1.02 Environmental Concerns and Recommendations

Whenever you see instructions in this manual to discard materials, you should first attempt to reclaim and recycle them. To preserve our environment, follow appropriate environmental rules and regulations when disposing of materials.

1.03 Data Logging

This vehicle is equipped with a control module that performs data logging capabilities.

This vehicle is equipped with one or more devices that record specific vehicle data and may perform some of the same functionality as a regulated Event Data Recorder but the device(s) are not subject to, nor designed pursuant to, 49 C.F.R. Part 563.

The type and amount of data recorded varies depending on how the vehicle is equipped (such as the brand of engine, if an air bag is installed, or if the vehicle features a collision avoidance system, etc.). GPS location data, fault codes, and other technical data may be recorded.

This data may help provide a better understanding of the circumstances of a crash.

Personal data such as name, gender, and age are not recorded. However, other parties such as law enforcement, could combine the data logger's contents with the type of personally identifying data routinely acquired during a crash investigation.

1.04 Emissions and Fuel Efficiency Compliance

This vehicle must be regularly inspected and maintained as indicated in the vehicle *Maintenance Manual*, and in the *Pre- and Post-Trip Inspections and Maintenance* chapter in this manual, in order to continue satisfactory performance and ensure coverage of the vehicle under the manufacturer's warranty.

Many maintenance procedures ensure that the vehicle and engine continue to comply with applicable emissions standards. Maintenance procedures, using components engineered to comply with greenhouse gas emissions and fuel efficiency regulations, may be performed by an authorized Daimler Truck North America dealer, an independent outlet, or the vehicle owner or operator.

The vehicle owner is responsible for determining the suitability of replacement components to maintain compliance with federal and local jurisdictional regulations. Components including, but not limited to, tires, cab/sleeper side extenders, chassis fairings, bumper, hood, vehicle speed limiters, and idle reduction timers are specifically designed and manufactured to exacting standards for regulatory fuel efficiency and greenhouse gas emissions compliance. It is important that these components are always replaced with components that meet or exceed the performance of the originally installed components.

1.05 Reporting Safety Defects

Vehicles domiciled in the USA thought to have a defect that could cause a crash, injury, or death, should immediately be reported to the National Highway Traffic Safety Administration (NHTSA) and Daimler Truck North America LLC.

If the NHTSA receives similar complaints, it may open an investigation; if it finds that a safety defect exists in a group of vehicles, it may order a recall and remedy campaign. However, NHTSA cannot become involved in individual problems between you, your dealer, or Daimler Truck North America LLC.

To contact NHTSA, call the Vehicle Safety Hotline toll-free at 1-888-327-4236 (TTY: 1-800-424-9153).

To e-mail NHTSA, go to <https://www.nhtsa.gov/safertruck> .

You can contact NHTSA by mail at: Administrator, NHTSA Headquarters, 1200 New Jersey Avenue SE, West Building, Washington, DC 20590.

For more information about motor vehicle safety, go to <https://www.nhtsa.gov/safertruck>

To contact Freightliner about a concern about a specific vehicle call the Customer Assistance Center at 1-800-385-4357 or complete a Product Concern Form .

Vehicles domiciled in Canada thought to have a defect that could cause a crash, injury, or death, should immediately be reported to Transport Canada and Daimler Truck North America LLC.

If Transport Canada receives similar complaints, it may open an investigation; if it finds that a safety defect exists in a group of vehicles, it may order a recall and remedy campaign. However, Transport Canada cannot become involved in individual problems between you, your dealer, or Daimler Truck North America LLC.

To contact Freightliner about a concern about a specific vehicle call the Customer Assistance Center at 1-800-385-4357 or complete a Product Concern Form .

To contact Transport Canada, call the Defect Investigations and Recalls Division toll-free in Canada at 1-800-333-0510 or 819-994-3328 in the Gatineau-Ottawa area or internationally.

You can also contact Transport Canada by mail at: Transport Canada, 330 Sparks Street, Ottawa, Ontario, K1A 0N5 Canada.

The following websites contain more information on Canadian recalls:

English: www.tc.gc.ca/recalls.

French: www.tc.gc.ca/rappels.

For additional road safety information, please visit the Road Transportation website:

English: www.tc.gc.ca/en/services/road

French: www.tc.gc.ca/fr/services/routier

- 2.01 Component Information Label 10
- 2.02 Component GWR Label..... 10
- 2.03 Federal Motor Vehicle Safety Standard Label 12
- 2.04 Canada Certification Label 14
- 2.05 Mexico Labeling 15
 - 2.05.01 Mexico Certification Label..... 15
 - 2.05.02 Spanish Weights and Measures Label..... 17
- 2.06 Emission Labels 18
 - 2.06.01 Aftertreatment System Indicators Label 18
 - 2.06.02 Vehicle Emission Control Information Label 18
 - 2.06.03 Noise Emission Control Labels 20
 - 2.06.04 Certified Clean Idle Label 21
- 2.07 Customer Assistance Label..... 21

2. Vehicle Identification

2.01 Component Information Label

NOTE: Labels shown in this chapter are examples only. Actual specifications may vary from vehicle to vehicle.

The component information label lists the vehicle model, identification number, and major component models and serial numbers.

For vehicles domiciled in Mexico, this label is in Spanish as shown in Fig.

1. [Component Information Label \(Spanish\)](#) Otherwise it is printed in English as shown in Fig.

2. [Component Information Label \(English\)](#).

FREIGHTLINER		INFORMACION DE COMPONENTES	
FABRICADO POR: DAIMLER VEHICULOS COMERCIALES MEXICO		USE EL NUMERO DE IDENTIFICACION DE VEHICULO CUANDO ORDENE PARTES.	
MODELO: MM106064S	MODELO BASE: M2106	FECHA DE FABRIC: 06/20	
NO. DE SERIE VEH: 3ALHCYD28MDMN5409	CLIENTE: V83361	DIST. ENTRE EJE: 230	
MOTOR: DD8 7.7L 6 CYL SINGLE STAGE 280 HP / 220	MOTOR: 936913S0010863		
TRANS PRINCIPAL: ALLISON 3000 RDS AUTOMATIC	TRANSMISION: 6511714361		
PTO: TRANSMISION	PTO:		
EJE DELANTERO: DETROIT DA-F-12.0-3 12.000# FF1 71.5 KPI	EJE DELANTERO: 739912B0165864		
EJE INT. 1RO: MT-40-14X 40.000# R-SERIES TANDEM REAR A	EJE INT. 1RO: DRA21199653		
EJE INT. 2DO:	EJE INT. 2DO:		
EJE INT. 3RO:	EJE INT. 3RO:		
EJE INT. 4TO:	EJE INT. 4TO:		
EJE INT. 5TO:	EJE INT. 5TO:		
EJE INT. 6TO: MT-40-14X 40.000# R-SERIES TANDEM REAR A	EJE INT. 6TO: DRA21199652		
EJE TRASERO: ELITE EY PAINT C	EJE TRASERO: 6.14		
PROVEEDOR DE PINTURA: CAB COLOR A: L0006EY	RELACION:		
NO. DE PINTURA:	PARA INFORMACION COMPLETA DE PINTURA, VER HOJA DE ESPECIFICACIONES DE L VEHICULO.		
09/29/2020		f080196s	

Fig 1, Component Information Label (Spanish)

FREIGHTLINER		COMPONENT INFORMATION	
MANUFACTURED BY: DAIMLER TRUCKS NORTH AMERICA LLC		SEE VEHICLE ID NO. WHEN ORDERING PARTS.	
MODEL: PX113064S T	BASE MODEL: CA113DC	DATE OF MFR: 07/15	
VEHICLE ID NO: 1FUJGBDV4GLZ29999	CUSTOMER: N00000	WHEELBASE: 164	
ENGINE MOD: DETROIT DD13 12.8L 410 HP / 1800 RPM 20	ENGINE NO: 999999S9999999		
MAIN TRANS MOD: DT12-DB-1450 HEAVY DUTY 12-SPEED DIRECT	TRANS NO: 99999999999999		
PTO MOD: PTO MOD:	PTO NO:		
FRONT AXLE MOD: MFS-12-143A 12.000# FF1 SINGLE FRONT AXL	FRONT AXLE NO: MON99999999		
1ST INT AXLE MOD: MT-40-14X 40.000# R-SERIES DUALTRAC 74-7	1ST INT AXLE NO: FOR99999999		
2ND INT AXLE MOD:	2ND INT AXLE NO:		
3RD INT AXLE MOD:	3RD INT AXLE NO:		
4TH INT AXLE MOD:	4TH INT AXLE NO:		
5TH INT AXLE MOD:	5TH INT AXLE NO:		
6TH INT AXLE MOD:	6TH INT AXLE NO:		
REAR AXLE MOD: MT-40-14X 40.000# R-SERIES DUALTRAC 74-7	REAR AXLE NO: FOR99999999		
PAIN MFR: ELITE BC PAINT C	RATIO: 2.47		
PAIN CODE: CAB COLOR A: L0306EB	FOR COMPLETE PAINT INFORMATION SEE VEHICLE SPECIFICATION SHEET.		
06/21/2016		f080196	

Fig 2, Component Information Label (English)

The component information label is located on the underside of the driver's sun visor.

2.02 Component GWR Label

NOTE: Vehicles manufactured for the Canadian market have a Canadian Certification label instead of a component GWR label.

The component GWR label, shown in Fig.3, [Component GWR Label \(English\)](#), provides maximum GWR ratings for each component. For vehicles domiciled in Mexico, this label is in Spanish as shown in Fig. 4, [Component GWR Label \(Spanish\)](#).

	MAXIMUM GWR BY COMPONENT (KG)/LB	COMPONENT	FRONT AXLE	1ST INT AXLE	2ND INT AXLE	3RD INT AXLE	4TH INT AXLE	5TH INT AXLE	6TH INT AXLE	REAR AXLE	COMPONENT GVWR	
		AXLES:	(5443) 12000	(9072) 20000							(9072) 20000	CHASSIS:
		SUSPENSION:	(5443) 12000	(9072) 20000							(9072) 20000	ENG/TRANS:
		TIRES:	(5601) 12350	(9253) 20400							(9253) 20400	5TH WHEEL:
		RIMS:	(6713) 14800	(11612) 25600							(11612) 25600	PARK BRAKE:
		HUBS/SPOKES:	(6032) 13300	(10432) 23000							(10432) 23000	AXLE:
		BRAKES:	(6032) 13300	(9072) 20000							(9072) 20000	VIN: 1FUJGBDV4GLZZ9999
		STEERING:	(6032) 13300									f080200
		06/21/2016										

Fig 3, Component GWR Label (English)

	PESO MAXIMO POR COMPONENTE (KG)/LB	COMPONENTE DELANTERO	PRIMERO	1RO	2DO	3RO	4TO	5TO	6TO	EJE TRASERO	PESO BRUTO DEL COMPONENTE	
		EJE:	(5443) 12000	(9072) 20000							(9072) 20000	LARGUERO:
		SUSPENSION:	(5443) 12000	(9072) 20000							(10596) 23360	MOTOR/TRANS: (36288) 80000
		NEUMATICOS:	(5996) 13220	(10596) 23360							(13426) 29600	QUINTA RUEDA:
		RIM/AROS:	(6713) 14800	(11793) 26000							(11793) 26000	FRENO ESTAC:
		CUBOS/RADIOS:	(6032) 13300	(9525) 21000							(9525) 21000	EJE:
		FRENOS:	(5443) 12000	(9525) 21000								VIN: 3ALHCYD28MDMN5409
		DIRECCION:	(6032) 13300									f080200s
		09/29/2020										

Fig 4, Component GWR Label (Spanish)

The component GWR label is located on the right-hand B-pillar as shown in Fig.5, [Right-Hand Door Frame Labels](#).

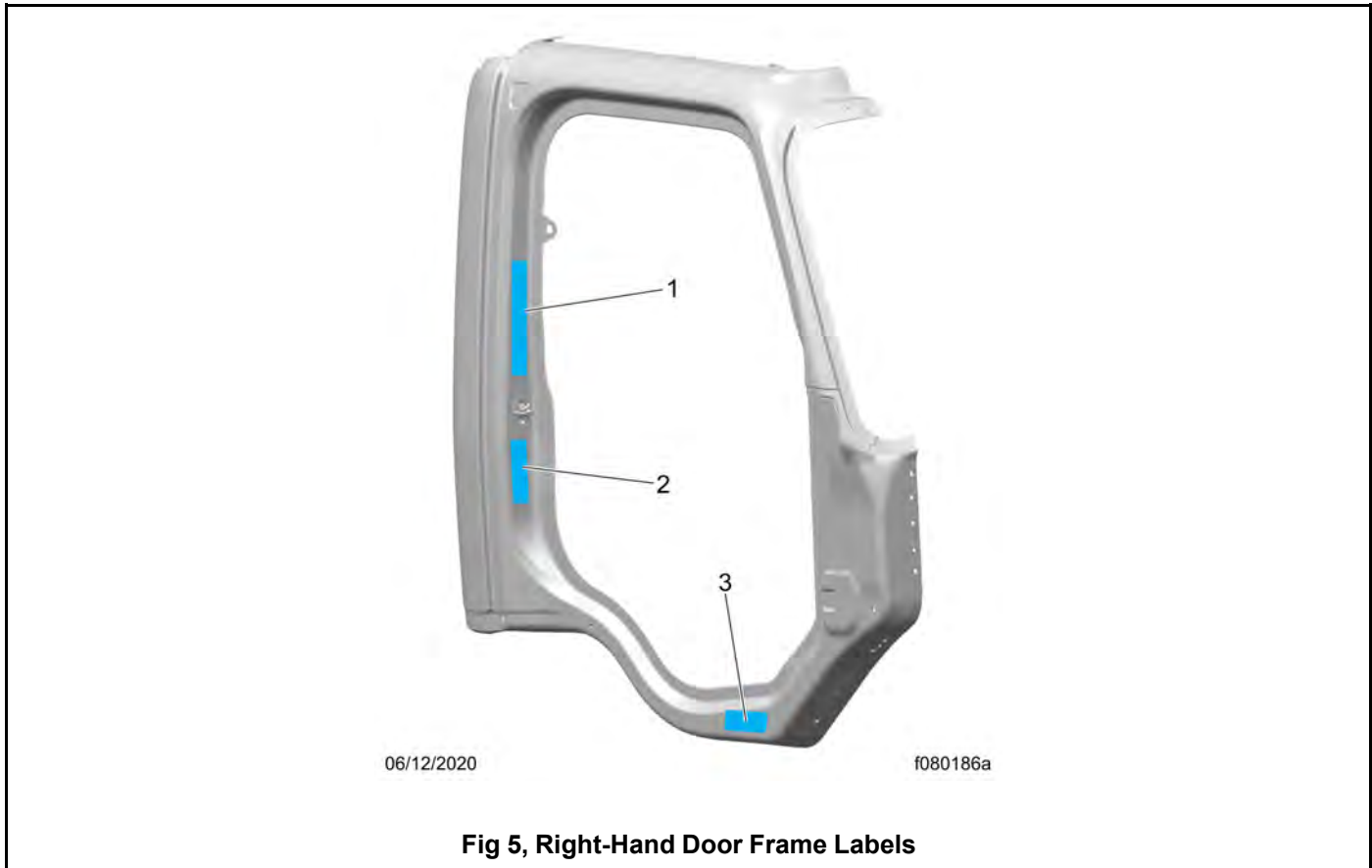

1. Component GWR Label (United States and Mexico)
2. Mexico Certification Label (Mexico)
3. Entry/Exit Warning Label

2.03 Federal Motor Vehicle Safety Standard Label

Tractors with or without fifth wheels manufactured for the U.S. are marked as certified by means of a federal motor vehicle safety standard (FMVSS) label, shown in Fig.6, [FMVSS Certification Label \(complete vehicle\)](#), which also lists suitable tire and rim combinations.

For vehicles domiciled in the United States, this label is attached to the left-hand side B-pillar as shown in Fig. 7, [Left-Hand B-Pillar Labels, United States](#).

For vehicles manufactured for U.S./Canada operation, this label is applied next to the Canada certification label as shown in Fig.8, [Left-Hand B-Pillar Labels, Joint United States Canada Operation](#).

Vehicles domiciled in Mexico are labeled with a Spanish weights and measurement label, as shown in Fig. 9, [Spanish Weights and Measures Label](#), that lists suitable tire and rim combinations.

 08/31/2020	MANUFACTURED BY: DAIMLER TRUCKS N.A. LLC DATE OF MFR: 07/15 GVWR/PNBV-KG: 23,587 GVWR/PNBV-LBS: 52,000 THIS VEHICLE COMPLIES WITH ALL APPLICABLE FEDERAL MOTOR VEHICLE SAFETY STANDARDS IN EFFECT AT THE DATE OF MANUFACTURE SHOWN ABOVE. VEHICLE ID NO: 1FUJGBDV4GLZZ9999 TYPE: TRUCK/TRACTOR TT/CT COUNTRY OF ORIGIN: U.S.A.	GAWR/PNBE KGS LBS FRONT AXLE: 5,443 1ST INT AXLE: 9,072 2ND INT AXLE: 3RD INT AXLE: 4TH INT AXLE: 5TH INT AXLE: 6TH INT AXLE: REAR AXLE: 9,072	GAWR/PNBE LBS 12,000 20,000 20,000 20,000 20,000 20,000 20,000 20,000	TIRES 275/80R22.5(G) 445/50R22.5(L) 445/50R22.5(L) 22.5X14.0 445/50R22.5(L)	RIMS 22.5X8.25 22.5X14.0 22.5X14.0	KPA COLD 758 827 827	PSI COLD 110 120 120	"S" S S S S S S S
	f080199							
	Fig 6, FMVSS Certification Label (complete vehicle)							

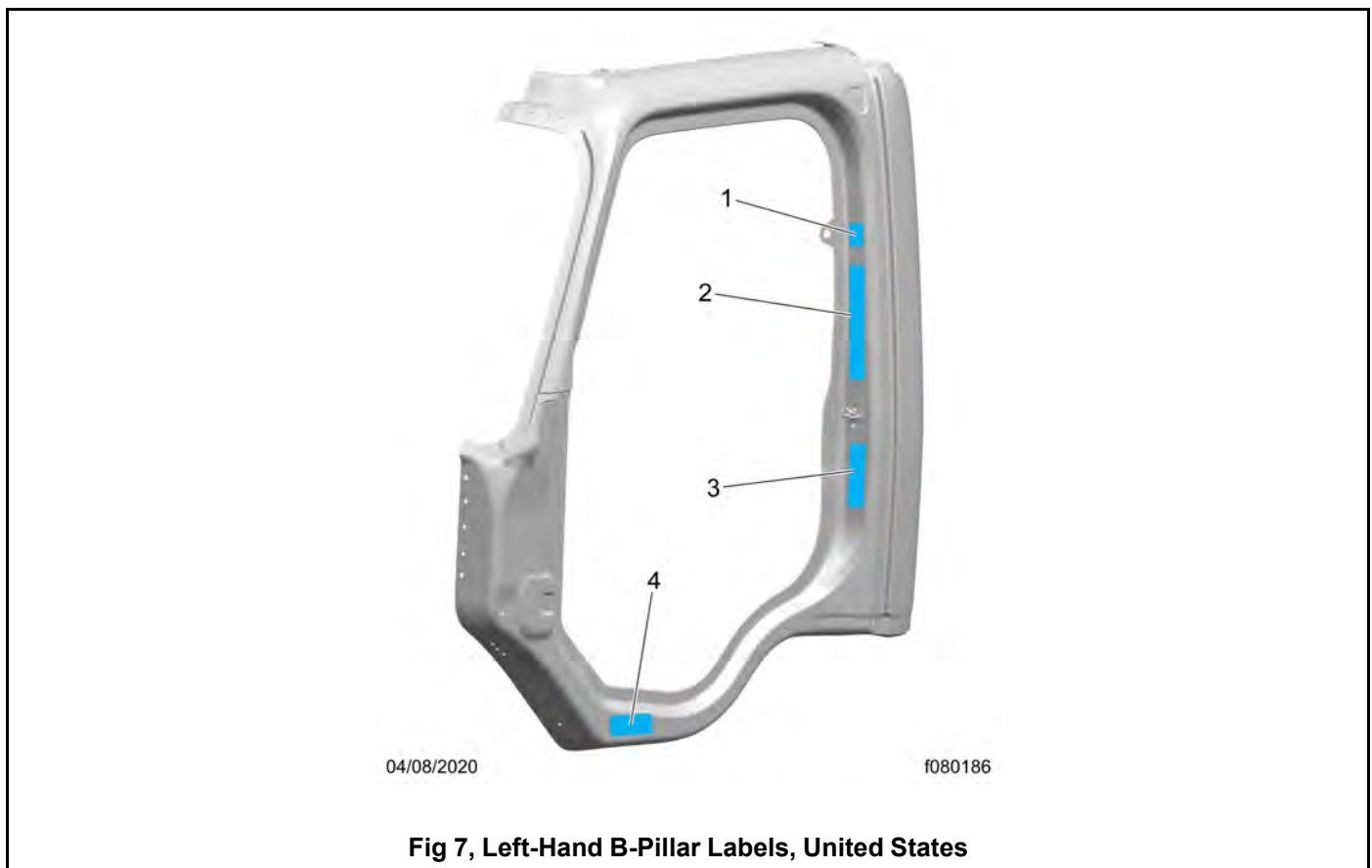

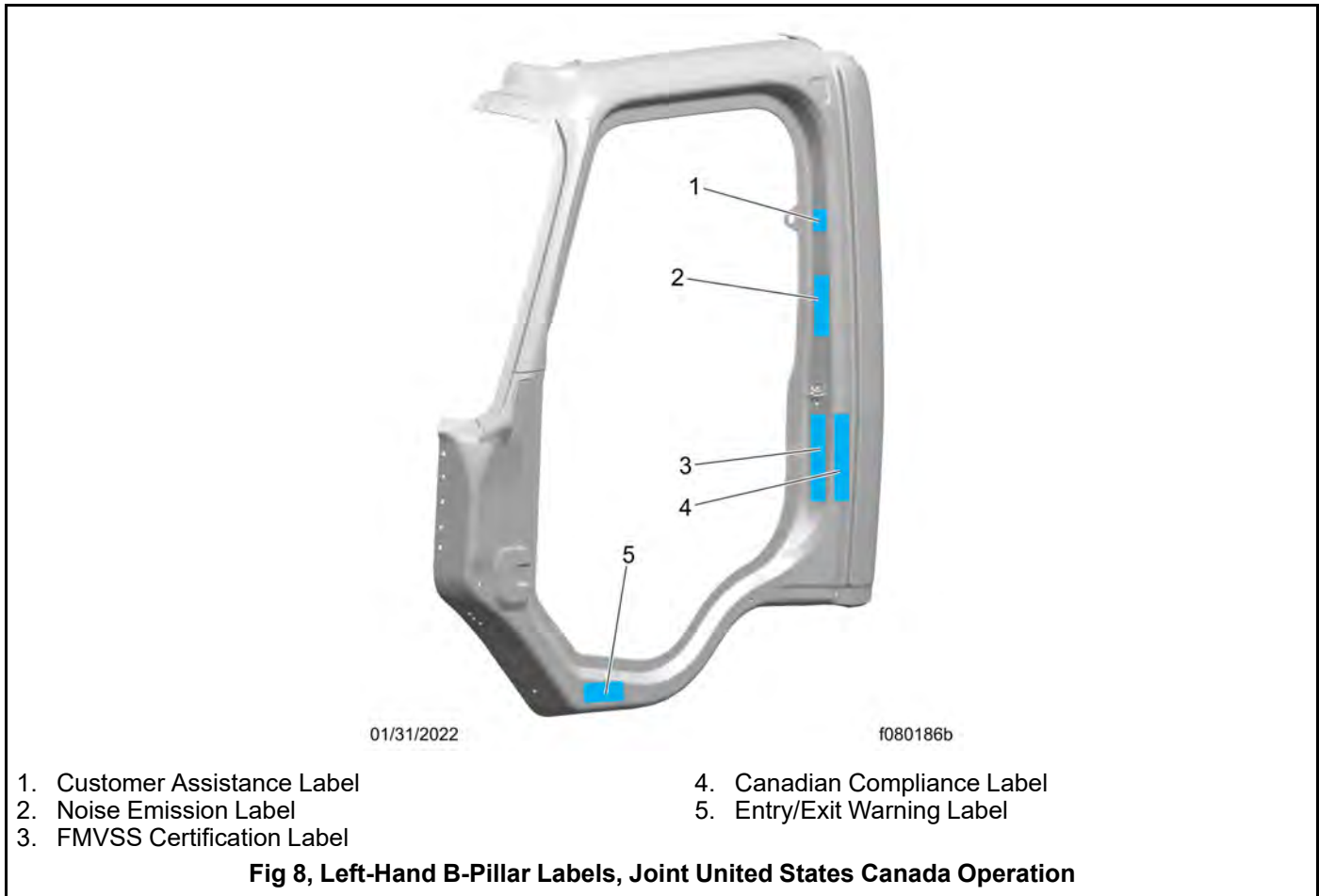

Fig 9, Spanish Weights and Measures Label

The tire and rim combinations listed on these labels are those that can be installed on the vehicle for the given gross axle weight rating. Tires and rims installed on the vehicle at the time of manufacture may have a higher load capacity than that certified by the tire and rim label.

If the tires and rims currently on the vehicle have a lower load capacity than that shown on the tire and rim label, then the tires and rims determine the load limitations on each of the axles.

Trucks built without a cargo body that are intended for service in the U.S. have an incomplete FMVSS vehicle certification label. This label will be attached to the incomplete vehicle document included with the vehicle, and certifies that the vehicle conforms to all applicable FMVSS regulations in effect on the date of completion. The final certification label must be attached by the final-stage manufacturer.

2.04 Canada Certification Label

Complete tractors with fifth wheels manufactured for Canada or dual Canada/United States operations, are marked with a Canada certification label, shown in Fig.10, [Canada Certification Label](#), attached to the right-hand B-pillar.

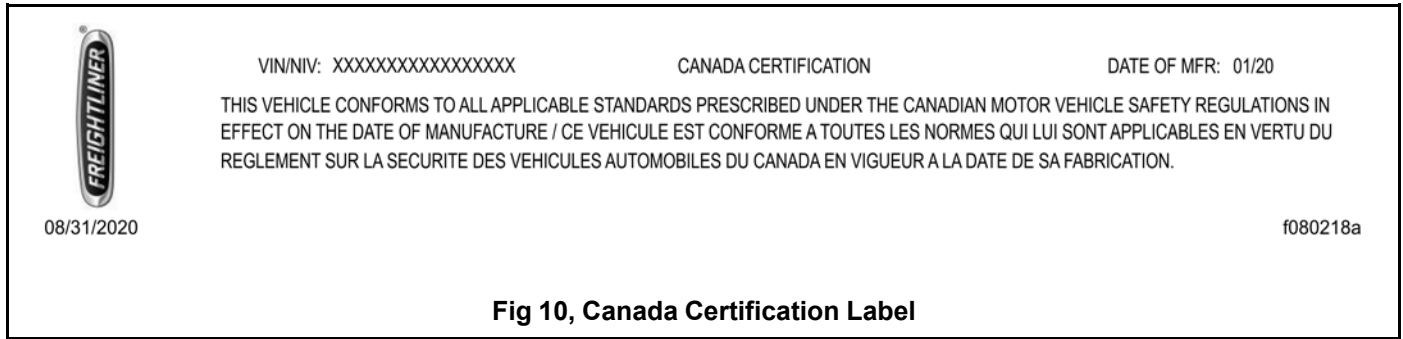

Fig 10, Canada Certification Label

NOTE: Vehicles manufactured for Canada will have a Canada certification label instead of a component GWR label.

Trucks built without a cargo body and tractors built without a fifth wheel that are intended for service in Canada will have an incomplete Canada certification label attached to the left-hand B-pillar. After completion of the vehicle, a complete Canada certification label must be attached by the final-stage manufacturer to certify that the vehicle conforms to all applicable vehicle safety regulations in effect on the date of completion.

2.05 Mexico Labeling

2.05.01 Mexico Certification Label

The Mexico certification label states that the vehicle complies with the Normas Oficiales Mexicanas (NOMs) standards in effect on the date the vehicle was manufactured. See Fig.11, [Mexico Certification Label](#).



Fig 11, Mexico Certification Label

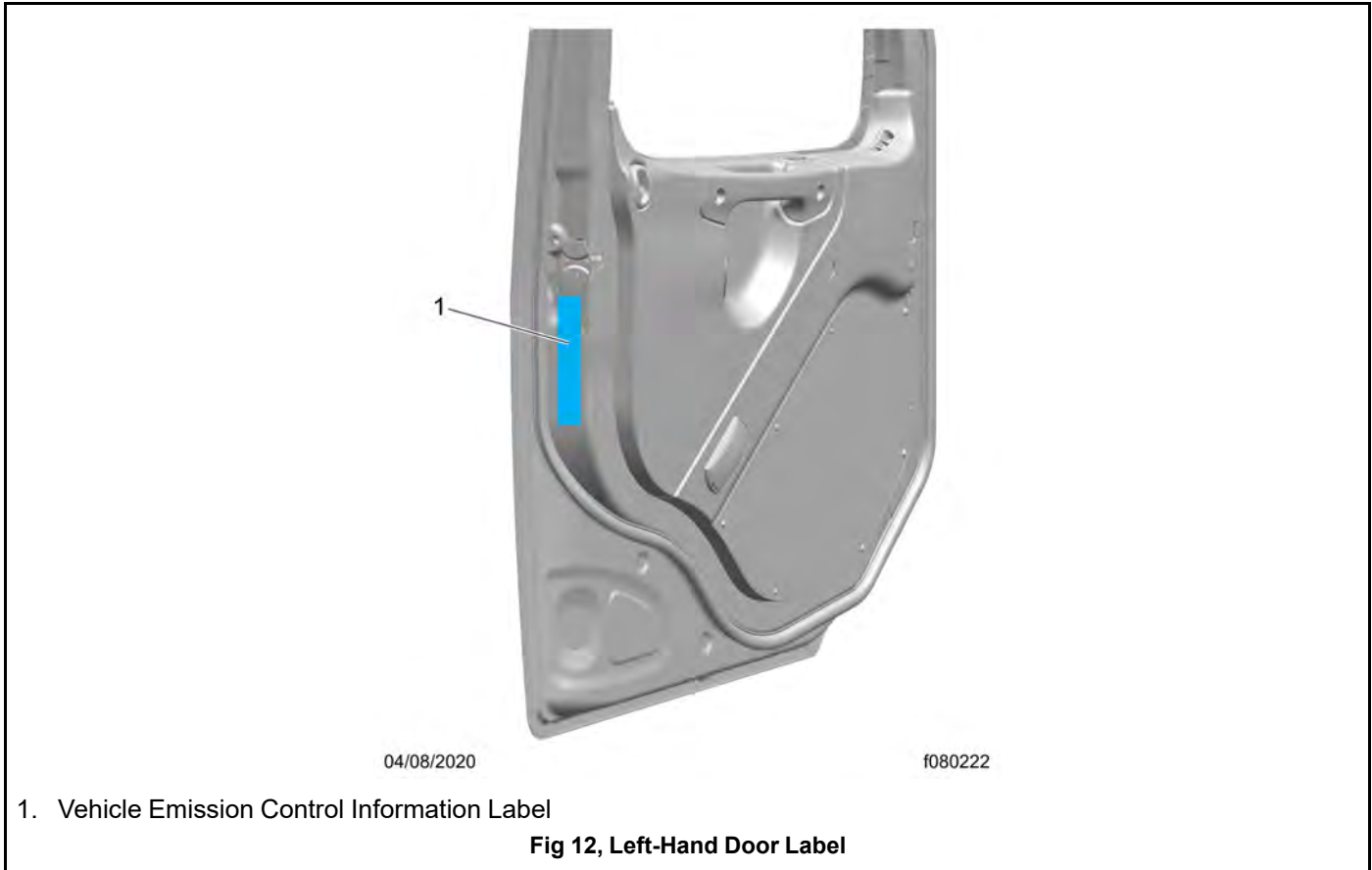

Vehicles domiciled in Mexico will have a Mexico certification label applied to the right-hand B-pillar as shown in Fig. 13, [Right-Hand Door Frame Labels](#).

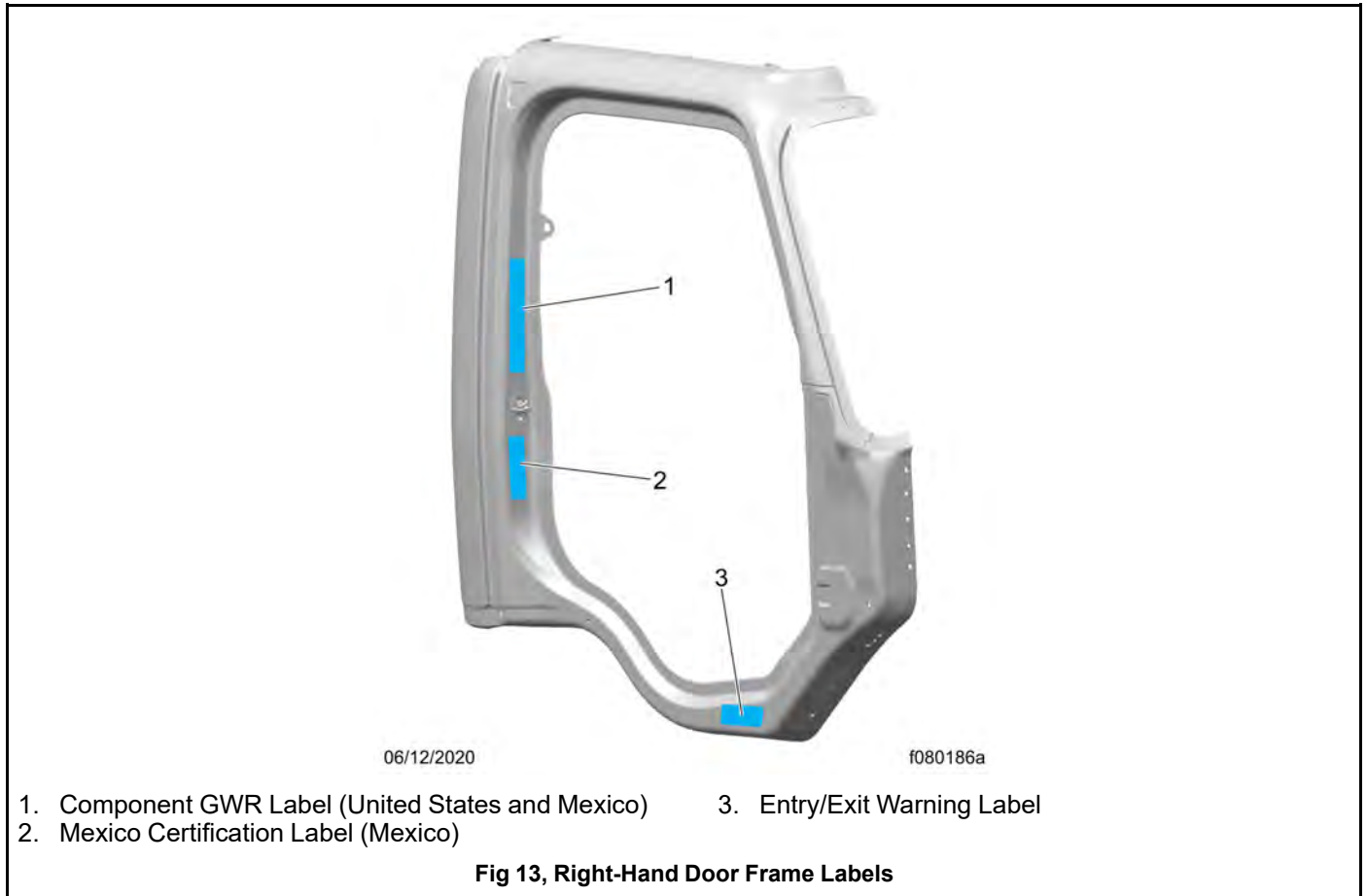

2.05.02 Spanish Weights and Measures Label

Vehicles with a Mexico certification label will also have a Spanish weights and measures label. See Fig. 14, [Spanish Weights and Measures Label](#) for an example.

	FABRICADO POR:	DAIMLER VEHICULOS COMERCIALES MEXICO	PV-KGS	PV-LBS	NEUMATICOS	RIM/AROS	KPA	PSI	"S"ENCILLA/ FRIO	"D"OBLE
	FECHA DE FABRICACION:	06/20								
	PBV (GVWR)-KG:	23,587	EJE DELANTERO:	5,443	12,000	11R22.5(H)	22.5X8.25	827	120	S
	PBV (GVWR)-LBS:	52,000	1RO:	9,072	20,000	11R22.5(G)	22.5X8.25	724	105	D
			2DO:							
		3RO:								
		4TO:								
		5TO:								
NO. SERIE VEHICULO:	3ALHCYD28MDMN5409	6TO:								
	CHASIS-CABINA	EJE TRASERO:	9,072	20,000	11R22.5(G)	22.5X8.25	724	105	D	
FABRIC. DE MEX.										
09/29/2020										f080199s

Fig 14, Spanish Weights and Measures Label

2.06 Emission Labels

2.06.01 Aftertreatment System Indicators Label

Model year 2007 and later diesel engines in vehicles domiciled in the U.S. or Canada are required to meet all EPA exhaust gas emission regulations effective as per the applicable emission model year, and are equipped with an emission aftertreatment system (ATS).

Vehicles domiciled outside of the U.S. and Canada may not have aftertreatment equipment, depending upon local statutory emissions guidelines.

See **Table 1.1** and **Table 1.2** at the end of this chapter for additional information on what EPA and GHG regulations apply to different model years.

See Fig. 15, **ATS Indicators, EPA10 and Newer** for information on the driver's visor warning label for important warning indicators in the instrument cluster that pertain to the ATS.

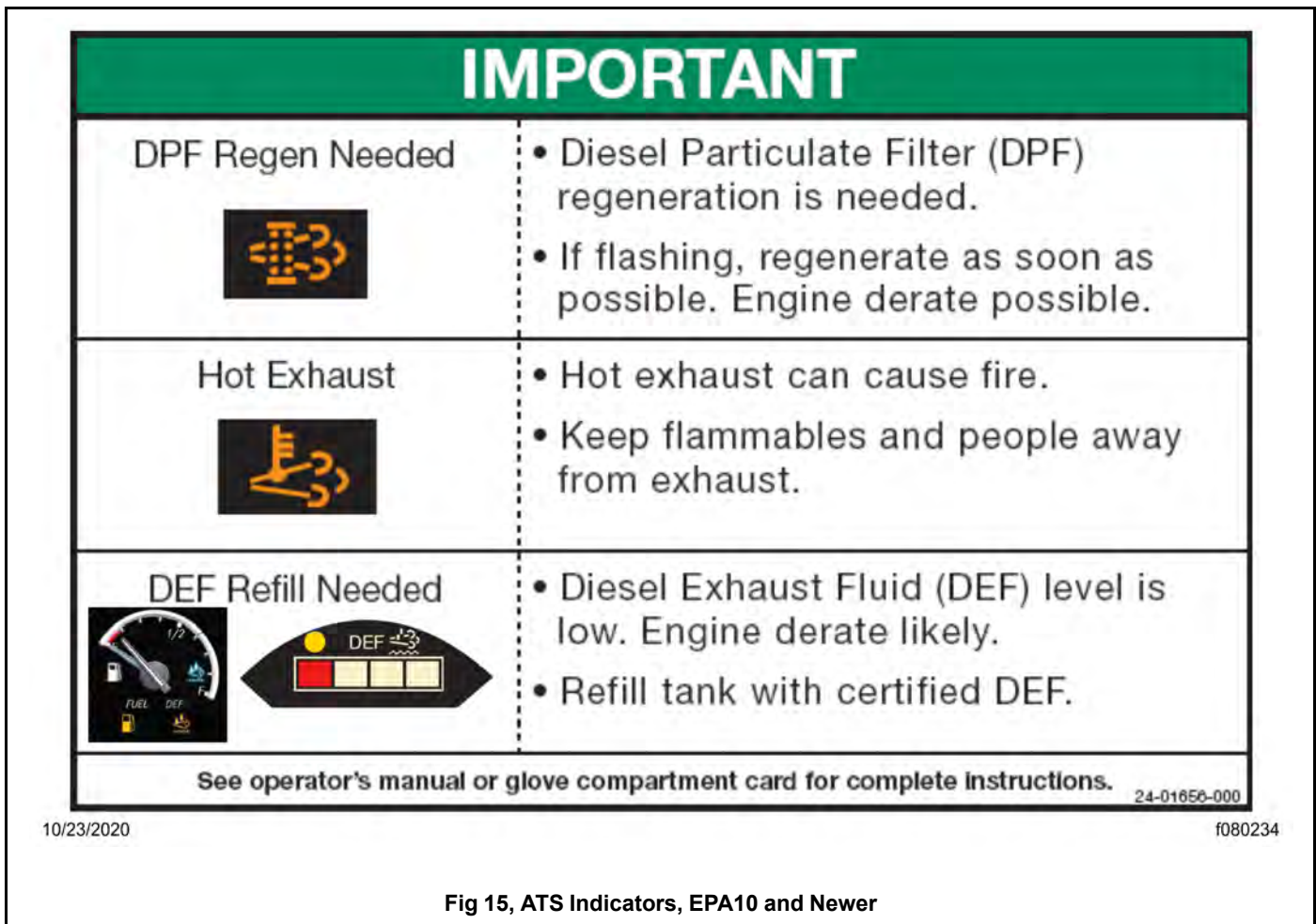

It is a violation of U.S. federal law to alter exhaust plumbing, ATS, or other components in any way that would bring the engine/vehicle out of compliance with certification requirements [Ref: 42 U.S.C. S7522(a) (3)]. It is the owner's responsibility to maintain the vehicle so that it conforms to EPA regulations.

2.06.02 Vehicle Emission Control Information Label

Model year 2013 and later vehicles meet requirements as specified by GHG14, GHG17 and GHG21 regulations, respectively. These vehicles are equipped with components that increase fuel efficiency and reduce greenhouse gas

(GHG) emissions. Components may include, but are not limited to, low-rolling resistance tires; aerodynamic devices such as hood, cab side extenders, and fuel tank fairings; vehicle speed limiters; and idle shutdown timers.

A vehicle emission control information label is located on the left-hand door. See Fig.17, [Left-Hand Door Label](#). Among other GHG relevant information the label indicates the emission model year of the vehicle. As this label is about meeting United States federal requirements, it is printed in English.

It is the owner's responsibility to maintain the vehicle so that it conforms to U.S. EPA and NHTSA regulations.

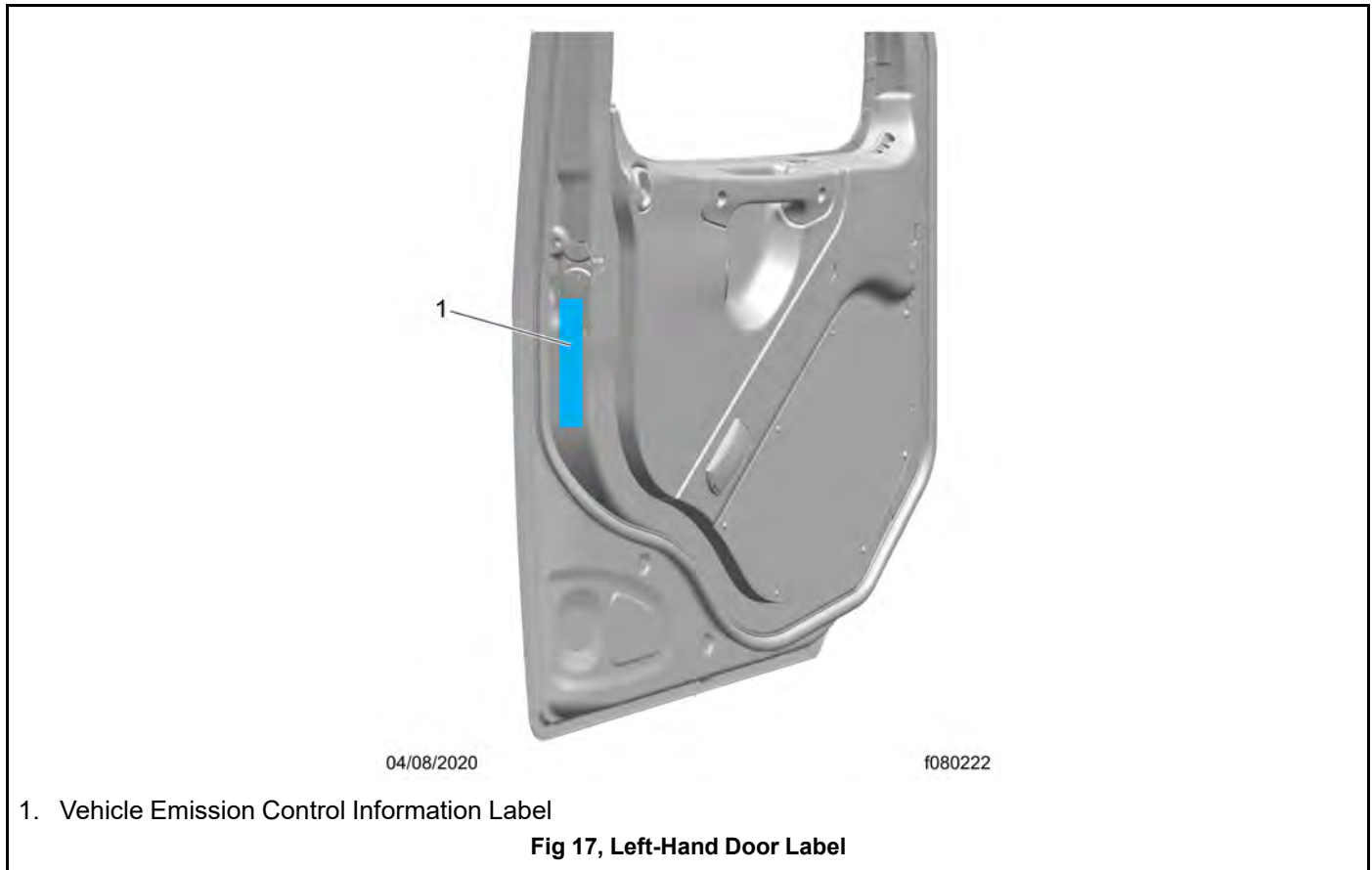
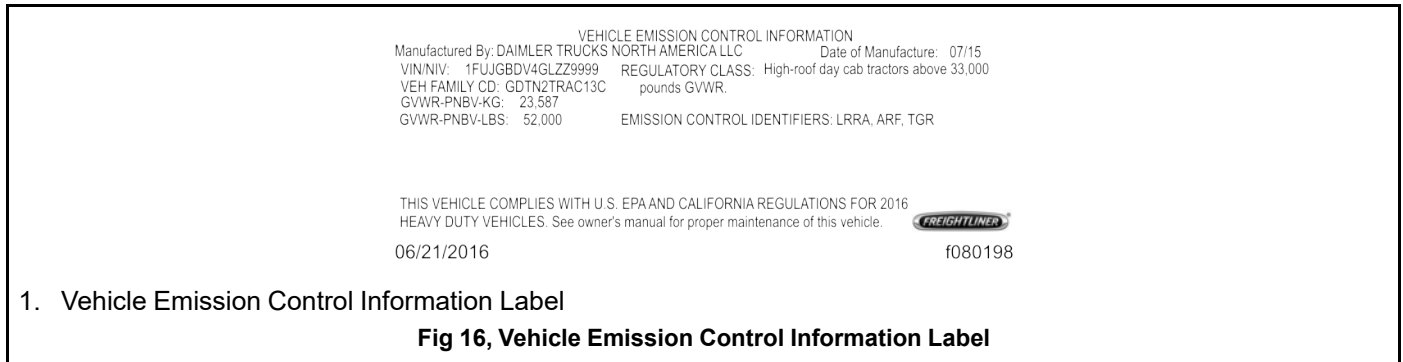

2.06.03 Noise Emission Control Labels

For vehicles manufactured for operation in the United States, an English language EPA noise emission control label is applied to attest that the vehicle conforms to United States EPA regulations for noise. See Fig. 18, [EPA Vehicle Noise Emission Control Label \(complete vehicle\)](#).

For vehicles manufactured for operation in Mexico, a Spanish language Normas Oficiales Mexicanas (NOM) vehicle noise emission control label attesting that the vehicle conforms to Mexican NOM regulations for noise is applied. See Fig. 19, [NOM Vehicle Noise Emission Control Label \(complete vehicle\)](#).

For vehicles manufactured for dual Mexico/United States operation, both labels are applied.

It is the owner's responsibility to maintain the vehicle so it conforms to all applicable regulations (EPA, NOM).

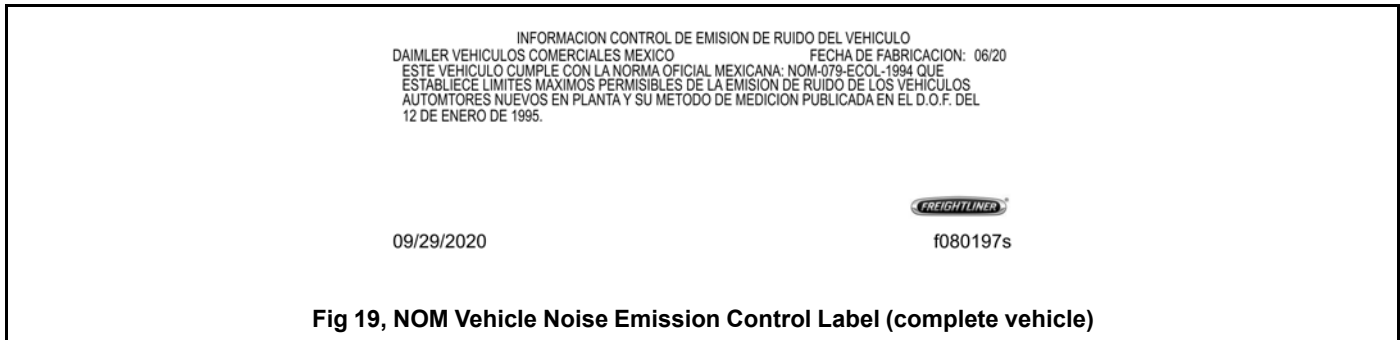
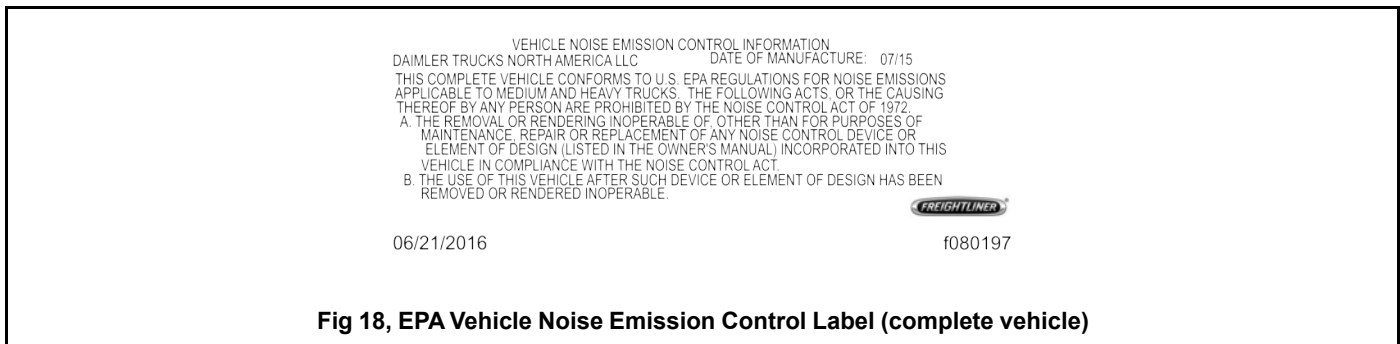

IMPORTANT: Certain Freightliner incomplete vehicles may be produced for the United States market with incomplete noise control hardware. Such vehicles will have an incomplete vehicle noise emission control information label. See Fig. 20, [EPA Vehicle Noise Emission Control Label \(incomplete vehicle\)](#). For such vehicles, it is the final-stage manufacturer's responsibility to complete the vehicle in conformity to the applicable regulations and label it for compliance.

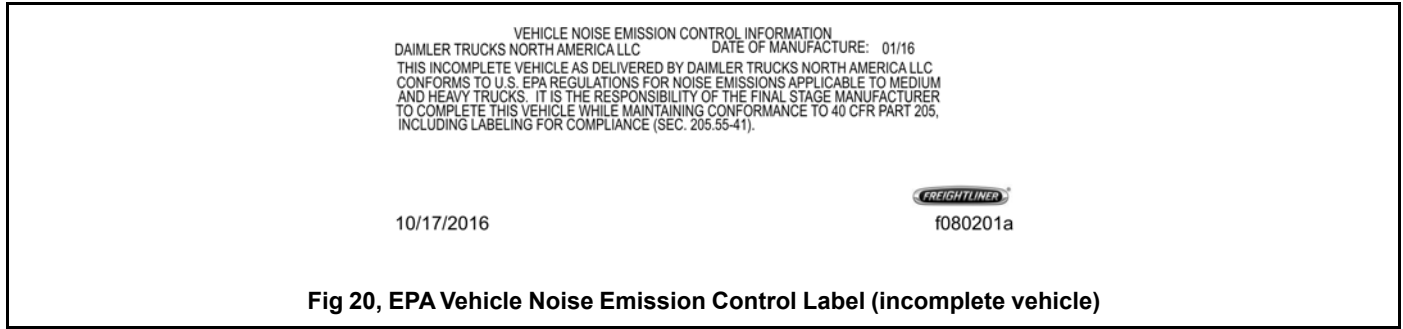

Fig 20, EPA Vehicle Noise Emission Control Label (incomplete vehicle)

2.06.04 Certified Clean Idle Label

The California Air Resources Board (CARB) requires model year 2008 and newer heavy-duty diesel engines to meet CARB's Heavy-Duty Diesel Engine Idling Requirement in order to limit emissions of particulate matter and NOx.

Certified vehicles are equipped with a label, shown in Fig.21, [CARB Clean Idle Label](#), that is placed near the bottom edge of the left-hand door.



Fig 21, CARB Clean Idle Label

2.07 Customer Assistance Label

The customer assistance center telephone number is printed on the customer assistance label. The label also includes a QR code encoded with the vehicle identification number (VIN), readable by dealer apps, to bring up information about the vehicle.

For vehicles domiciled in Mexico this label will be in Spanish as shown in Fig.22, [Customer Assistance Label, Spanish](#). For vehicles domiciled in the United States it will be printed in English as shown in Fig. 23, [Customer Assistance Label, English](#).



Fig 22, Customer Assistance Label, Spanish



The customer assistance label is located on the left-hand B-pillar, as shown in Fig. 1.7 .

Emission Regulations by Model Year		
Model Year	Engine Regulation	Vehicle Regulation
2021–and later	EPA10, GHG21	GHG21

EPA Regulations	
Regulation	Emissions Components
EPA10 (Reduction of NOx emissions to 0.2 g/bhp-hr)	EPA07-type ATD, with additional selective catalyst reduction (SCR) technology that utilizes diesel exhaust fluid (DEF) to convert NOx to nitrogen and water vapor.
GHG21	GHG14/17 components plus additional components including, but not limited to, transmissions, axles, predictive technologies, idle reduction technologies for vocational vehicles, and tire pressure monitoring systems.

- 3.01 Key, Door Locks, and Handles 24
- 3.02 Remote Keyless Entry 25
 - 3.02.01 Keyless Fob Use..... 25
 - 3.02.02 Key Fob Programming 26
 - 3.02.03 Specifications 27
- 3.03 Grab Handles and Access Steps 27
- 3.04 Cab Entry and Exit 27
 - 3.04.01 General Description 27
 - 3.04.02 Entering from the Driver's Side..... 28
 - 3.04.03 Exiting from the Driver's Side 29
 - 3.04.04 Entering from the Passenger's Side..... 29
 - 3.04.05 Exiting from the Passenger's Side 29
- 3.05 Back-of-Cab Access 30
 - 3.05.01 General Information 30
 - 3.05.02 Climbing Up to the Back-of-Cab 31
 - 3.05.03 Climbing Down from the Back-of-Cab 31
- 3.06 Hood Opening and Closing 32
 - 3.06.01 General Information 32
 - 3.06.02 To Open the Hood 32
 - 3.06.03 To Close the Hood 32

3. Vehicle Access

3.01 Key, Door Locks, and Handles

A common key operates the ignition switch and the door locks.

IMPORTANT: Each key is numbered. Record the number so a duplicate key can be made, if needed.

To unlock the driver's door from outside the cab using a key, insert the key and turn it one-quarter turn clockwise. See Fig.24, [Exterior Door Handle](#). To remove the key, turn it counterclockwise to the original position. Pull out on the door pull handle to open the door.

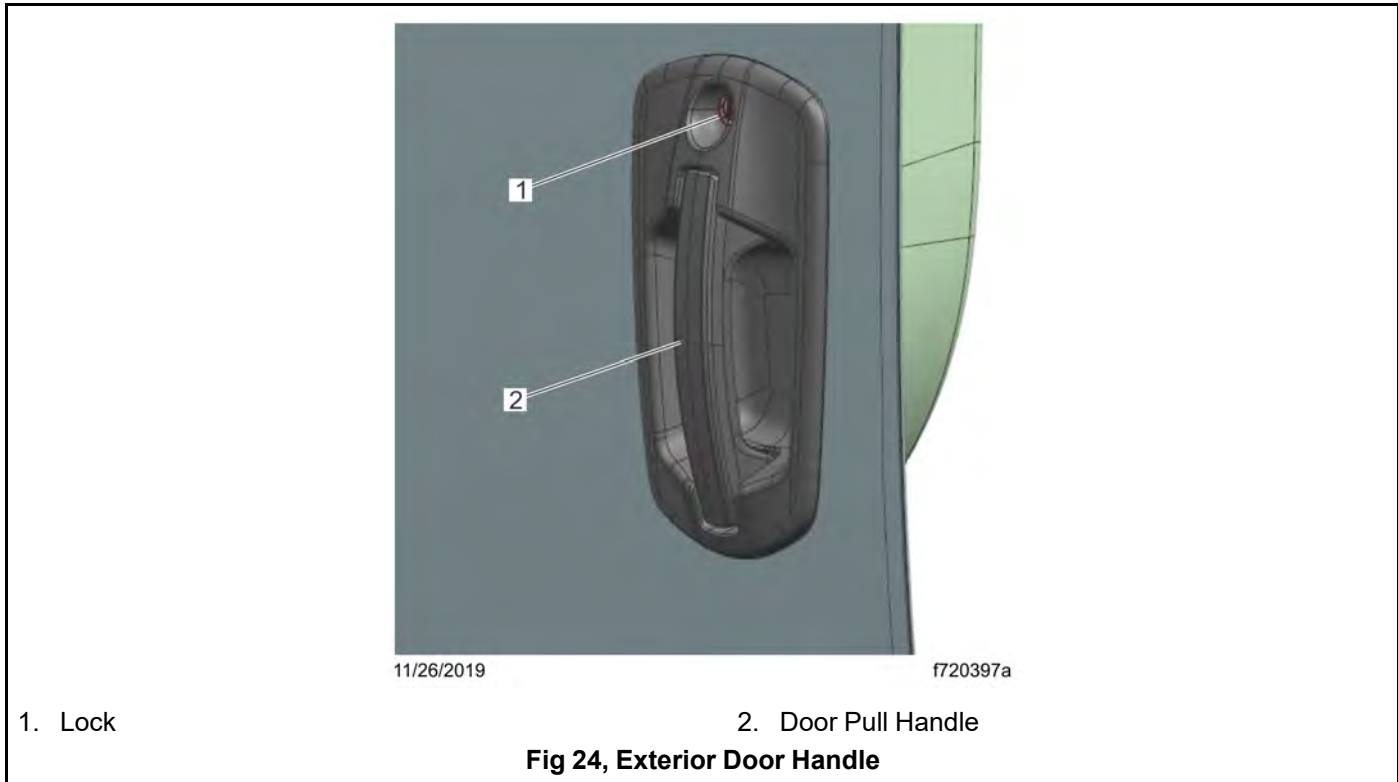

To unlock the passenger's door from outside the cab, insert the key in the lock and turn it one-quarter turn counterclockwise. Turn the key clockwise to the original position to remove it.

NOTE: The cab door locks can be operated when the doors are open.

Close the door if it is open. To lock a door from outside the cab, insert the key in the lock and turn it in the direction opposite to the unlocking direction (counterclockwise for the driver's door, clockwise for the passenger's door).

To lock either door from inside the cab, push the lock button downwards. See Fig.25, [Door Interior](#).



1. Lock Button
2. Door Lever

3. Door Control Panel
4. Door-Panel-Integrated Grab Handle

Fig 25, Door Interior

To open the door from the inside, lift up on the door lever. This will unlatch the door whether or not it is locked.

To unlock the door without unlatching it, pull the lock button upwards.

3.02 Remote Keyless Entry

3.02.01 Keyless Fob Use



DANGER:

Do not ingest the key fob battery. The button cell battery in this key fob is a chemical burn hazard.

Always keep the key fob and button cell batteries away from children.

Always safely dispose of used batteries.

If the button cell battery in this key fob is swallowed, it can cause severe internal burns within two hours and can lead to death. If you think a battery might have been swallowed or otherwise placed inside any part of the body, seek immediate medical attention.

If the battery compartment does not close securely, stop using the key fob.

**CAUTION:**

Failure to observe the following safety instructions can result in an explosion, fire, damage to the key fob, electric shock and other injuries, as well as property damage:

**NOTICE:**

Do not drop the key fob. Doing so could damage the fob, including damage to the battery compartment allowing the button cell battery to fall out.

The remote entry key fob can be used to remotely unlock and lock the doors, start and end the pre-trip light check, and move down the door windows. See Fig.26, [Key Fob](#).



1. Lock Button
2. Unlock Button

3. Lamp Check Button

Fig 26, Key Fob

- To unlock all doors, press the unlock button.
- To lock all doors, press the lock button.
- To start or end the pre-trip light check, press the lamp check button.
- To move down the door windows, press the unlock button for three seconds.

3.02.02 Key Fob Programming

A maximum of four fobs can be programmed to work on one vehicle.

Whenever a new fob is needed, all existing fobs must be reprogrammed. Any existing fobs that were previously programmed will no longer work unless reprogrammed.

To have the key fobs programmed, take the vehicle to an authorized Freightliner dealer or service facility.

3.02.03 Specifications

The key fob uses a radio frequency link for communication between the fob and the vehicle.

3.03 Grab Handles and Access Steps

**CAUTION:**

Slipping or falling from the vehicle can result in personal injury or property damage.

Always maintain three-point contact with the vehicle when entering or exiting the cab. Three-point contact means both feet and one hand, or both hands and one foot.

Wet or dirty shoes greatly increase the chance of slipping or falling. If your shoes are wet or dirty, be especially careful when entering or exiting the vehicle.

When steps are mounted on battery box covers, make sure that the cover is latched and secure before using the steps.

Do not step on the fuel tank, battery box, frame, etc., unless adequate slip resistant surfaces and handholds are provided.

Be careful not to get hands or feet tangled in hoses or other back-of-cab equipment as it could cause a trip and fall.

For ease of entry and exit, there are grab handles on the inner B-pillar, and optional grab handles on the A-pillars. In addition, the inner door grab handle and steering wheel may be used to provide a secure handhold. One or two access steps provide secure footholds.

The grab handles, access steps, and steering wheel are all part of the cab access system. Use these when getting into or out of the cab.

3.04 Cab Entry and Exit

3.04.01 General Description

Use the cab access system (grab handles, access steps, and steering wheel) to enter or exit the cab. See Fig. 27, [Cab Access System, Driver's Side \(crew cab shown\)](#) and see Fig. 28, [Cab Access System, Passenger's Side \(crew cab shown\)](#).



- | | |
|---|-----------------------|
| 1. Door-Panel-Integrated Grab Handle | 6. Top Step, Back |
| 2. Steering Wheel | 7. Bottom Step, Back |
| 3. B-Pillar Grab Handle | 8. Bottom Step, Front |
| 4. Exterior Grab Handle, Front | 9. Top Step, Front |
| 5. Exterior Grab Handle, Back (not shown) | |

Fig 27, Cab Access System, Driver's Side (crew cab shown)



- | | |
|--------------------------------------|-----------------------|
| 1. Exterior Grab Handle, Back | 6. Top Step, Front |
| 2. Exterior Grab Handle, Front | 7. Bottom Step, Front |
| 3. A-Pillar Grab Handle | 8. Top Step, Back |
| 4. Door Panel Integrated Grab Handle | 9. Bottom Step, Back |
| 5. B-Pillar Grab Handle | |

Fig 28, Cab Access System, Passenger's Side (crew cab shown)

3.04.02 Entering from the Driver's Side

To enter the cab from the driver's side:

1. Open the driver's door and place anything that you are carrying in the cab.

2. Grasp the door-panel-integrated grab handle with your left hand, and the B-pillar with your right hand, or grasp the B-pillar grab handle with both hands. Reach up as far as is comfortable.
3. Place a foot on the step and pull yourself up. Shift your grasp on the B-pillar grab handle higher. If there is a second step, place the opposite foot on it and pull yourself up again.
4. Grasp the steering wheel with your left hand and step into the cab.

3.04.03 Exiting from the Driver's Side

To exit the cab from the driver's side:

**CAUTION:**

Always face in when exiting the cab. Do not attempt to exit with your back to the cab as you would going down a flight of stairs. It is easier to slip or lose your balance when exiting this way, and there is a greater likelihood of personal injury.

1. Place any items you wish to take in an accessible location on the seat or cab floor and make sure they will not get in your way as you exit.
2. Facing inward, grasp the steering wheel with your left hand and the B-pillar grab handle with your right hand.
3. Place your left foot on the top step.
4. Move your left hand to the door panel integrated grab handle, and your right hand lower down the B-pillar grab handle.
5. Move your right foot onto the step.
6. Step to the second step or ground with your left foot first, sliding your grasp down the grab handle. If there is another step down, place your right foot down first and then your left.
7. Release the grab handles or other handholds.
8. Retrieve any items from the cab that you wish to take with you.

3.04.04 Entering from the Passenger's Side

To enter the cab from the passenger's side:

1. Open the passenger's door, and place anything that you are carrying into the cab.
2. Facing the cab, grasp the B-pillar grab handle with your left hand and the door panel integrated grab handle with your right hand.
3. Step up on the bottom step with your left foot and pull yourself up.
4. Grasp the grab handles higher up.
5. Step up to the next step or the cab with your right foot.
6. Move your right hand to the A-pillar grab handle.
7. Move your left hand up the B-pillar grab handle.
8. Step into the cab.

3.04.05 Exiting from the Passenger's Side

To exit the cab from the passenger's side:

**CAUTION:**

Always face in when exiting the cab. Do not attempt to exit with your back to the cab as you would going down a flight of stairs. It is easier to slip or lose your balance when exiting in this way and there is a greater likelihood of personal injury.

1. If you wish to take any items with you, place them in an accessible location on the seat or cab floor and make sure they will not get in your way as you exit.
2. While standing up from the seat facing inward, grasp the A-pillar grab handle with both hands, then place your right foot on the step.
3. Move your left hand to the B-pillar grab handle, and your right hand to the door panel integrated grab handle.
4. Place your left foot on the step.
5. Step to the second step or ground with your left foot first, sliding your grasp down the grab handles. If there is another step down, place your right foot down first and then your left.
6. Release the grab handles or other handholds.
7. Retrieve any items from the cab that you wish to take with you.

3.05 Back-of-Cab Access

3.05.01 General Information

When trailer air and electrical connections cannot be reached conveniently from the ground, Federal Motor Carrier Safety Regulations require commercial carriers to provide back-of-cab access.

Optional grab handles are mounted on each cab sidewall, on the left sidewall only, or on the cab back wall. See Fig. 29, [Back-of-Cab Access Supports \(typical\)](#). Steps are mounted either on the fuel tank(s) or on metal brackets. When a deck plate is necessary, it is mounted across the top of the frame rails.

IMPORTANT: Climb onto, and down from, back-of-cab access facing in toward the vehicle, as you would on a ladder. Do not climb up or down facing out away from the vehicle.

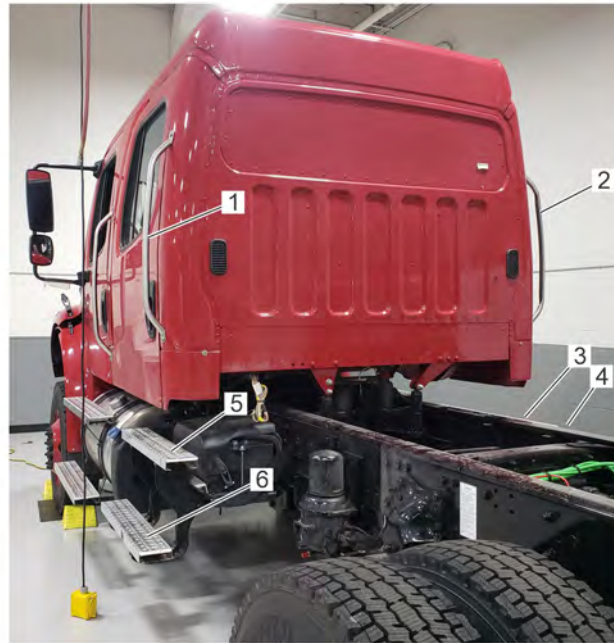

01/31/2023

f602957

- | | |
|--|---|
| 1. Grab Handle, Rear Driver Side | 4. Passenger-Side Bottom Step, Back (not shown) |
| 2. Grab Handle, Rear Passenger Side | 5. Driver-Side Top Step, Back |
| 3. Passenger-Side Top Step, Back (not shown) | 6. Driver-Side Bottom Step, Back |

Fig 29, Back-of-Cab Access Supports (typical)



CAUTION:

Wet or dirty shoe soles greatly increase the chance of slipping or falling. If your soles are wet or dirty, be especially careful when climbing onto, or leaving, the back-of-cab area.

Always maintain three-point contact with the back-of-cab access supports while entering and exiting the back-of-cab area. Three-point contact means both feet and one hand, or both hands and one foot, on the grab handles, steps, and deck plates. Other areas are not meant to support back-of-cab access, and grabbing or stepping in the wrong place could lead to a fall and personal injury.

Be careful not to get hands or feet tangled in hoses or other back-of-cab equipment. Doing so could cause a trip and fall with possible injury.

3.05.02 Climbing Up to the Back-of-Cab

When climbing onto the deck plate, do the following:

1. Grasp the sidewall grab handle with both hands. Reach up as far as is comfortable.
2. Place one foot on the bottom step and pull yourself up.
3. Place your other foot on the top step.
4. Move your lower hand to a higher position on the grab handle.
5. Step onto the deck plate.

3.05.03 Climbing Down from the Back-of-Cab

To climb down from the back-of-cab area:

1. Grasp the sidewall grab handle with both hands.
2. Step one foot at a time onto the top step.
3. Move your upper hand to a lower position on the grab handle.
4. Move one foot to the bottom step.
5. Move your upper hand to a lower position on the grab handle.
6. Step to the ground with your upper foot first.

3.06 Hood Opening and Closing

3.06.01 General Information

The hood can be raised to a full-open position. A torsion bar helps you to raise the hood, and to lower it to the operating position. Hood restraint cables prevent the hood from overtravel. A hood damper limits the closing speed. In the operating position, the hood is secured to the cab-mounted half-fenders by a hold-down latch on each side of the hood.

3.06.02 To Open the Hood

1. Apply the parking brakes.
2. Release both hood hold-down latches by pulling the ends outward. See Fig.30, [Hood Hold-Down Latch](#).

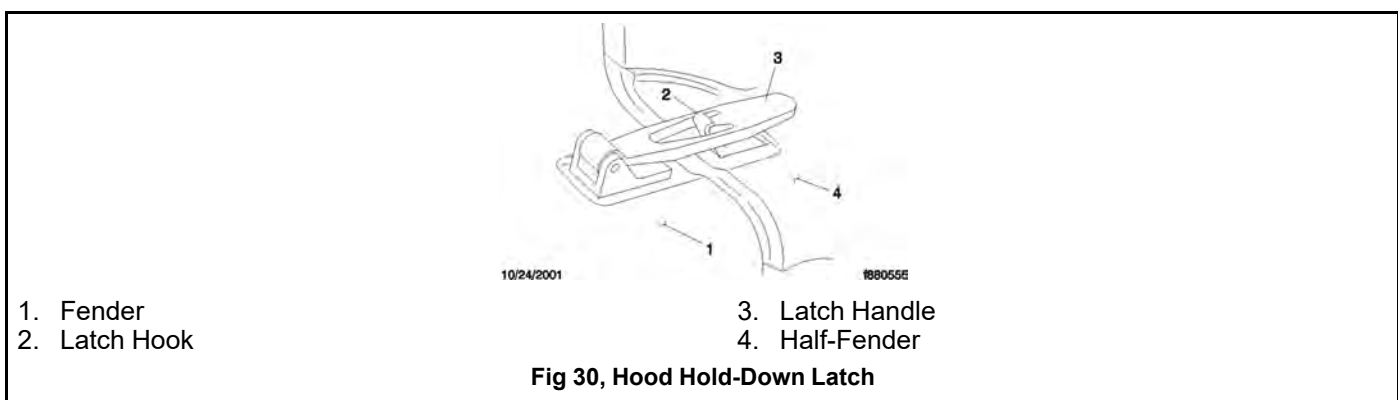

CAUTION:

Do not let the hood free-fall to the full-open position. To do so could cause damage to the hood or hood straps.

3. Standing in front of the hood, raise the rear of the hood upward until it reaches the over-center position (45 degrees from vertical). Then slowly bring it to a stop.

3.06.03 To Close the Hood

1. Push the hood over center.
2. As the hood goes over center, the damper automatically slows its rate of descent. If needed, you can also slow its rate of descent with your hand.
3. Make sure the hood is flush with the cowl, then secure the hood by engaging both hood hold-down latches.

IMPORTANT: Make sure that both hold-down latches are fully engaged before operating the vehicle.

- 4.01 Instrumentation Control Unit: ICUC 37
 - 4.01.01 General Information 37
 - 4.01.02 Ignition Sequence 38
 - 4.01.03 ICUC Screen Navigation 38
 - 4.01.04 ICUC Steering Wheel Switch Pods 41
- 4.02 Driver Display Overview: ICUC 42
 - 4.02.01 ICUC Alert Messages 42
 - 4.02.02 ICUC Time and Alarm Settings 43
 - 4.02.03 Time Settings: Display Format 44
 - 4.02.04 Setting An Alarm 44
 - 4.02.05 Main ICUC Driver Display Screens 45
 - 4.02.06 Software Updates 56
 - 4.02.07 JVCKENWOOD Interactive Touchscreen Display 58
- 4.03 Digital Gauges and System Monitors: ICUC 58
 - 4.03.01 ICUC Gauges 58
 - 4.03.02 Engine Oil Temperature Gauge 59
 - 4.03.03 Turbocharger Boost Pressure Gauge 61
 - 4.03.04 Transmission Oil Temperature Gauge 62
 - 4.03.05 Application Air Pressure Gauge 63
 - 4.03.06 DEF and Diesel Particulate Filter Monitoring 64
 - 4.03.07 Tire Pressure Monitoring System 64
 - 4.03.08 Other ICUC Gauges and Measurements 65
 - 4.03.09 Alerts 65
 - 4.03.10 Battery Voltage 65
 - 4.03.11 Diagnostics 66
 - 4.03.12 Engine Maintenance 66
 - 4.03.13 Maintenance System 66
 - 4.03.14 Transmission Prognostics 67
 - 4.03.15 Suspension Air Pressure 67
 - 4.03.16 ICUC Vehicle Operations: Vehicle Settings 68
 - 4.03.17 Cruise Control 68

4.03.18 Transmission	68
4.03.19 Engine Idle Adjust	69
4.03.20 Optimized Idle	69
4.04 Infotainment: ICUC	70
4.04.01 Safety Information	70
4.04.02 Navigation and Infotainment Reception	70
4.04.03 General ICUC Infotainment Information	70
4.04.04 ICUC Infotainment Screens	70
4.04.05 ICUC Audio Features	72
4.04.06 Weather Radio (WX)	72
4.04.07 ICUC Telephone Features	73
4.05 Analog Instruments	74
4.05.01 Air Intake Restriction Gauge	74
4.05.02 Application Air Pressure Gauge	75
4.05.03 Coolant Temperature Gauge	75
4.05.04 Drive Axle Oil Temperature Gauges	76
4.05.05 Engine Oil Pressure Gauge	77
4.05.06 Engine Oil Temperature Gauge	79
4.05.07 Fuel/Diesel Exhaust Fluid (DEF) Gauge	79
4.05.08 Primary and Secondary Air Pressure Gauges	80
4.05.09 Speedometer	81
4.05.10 Suspension Air Pressure Gauge	82
4.05.11 Tachometer	82
4.05.12 Transmission Fluid Temperature Gauge	83
4.05.13 Turbocharger Boost Pressure Gauge	84
4.05.14 Voltmeter	84
4.06 Overhead Instrument Panel	85
4.07 Warnings, Indicators, and Messages	85
4.07.01 Audible Alerts: ICUC	85
4.07.02 Warnings, Indicators, and Messages	85
4.07.03 Engine Protection System	99

4. Instruments

4.01 Instrumentation Control Unit: ICUC

4.01.01 General Information

The instrumentation control unit (ICU) provides the driver with engine and vehicle information. An M2 Plus vehicle will be equipped with an ICUC. See Fig.31, [Instrument Cluster Overview - ICUC](#) for a typical ICUC layout.

This section provides general system and operating instructions for ICUC components. Following sections provide more detailed information.



Fig 31, Instrument Cluster Overview - ICUC

1. Speedometer
2. Coolant Temperature Gauge
3. Primary and Secondary Air Pressure Gauge
4. Fuel and DEF Level Gauge
5. Engine Oil Pressure Gauge
6. Tachometer
7. Driver Display
 - Home
 - Drive Time Systems
 - Vehicle Operations
 - Maintenance
 - Infotainment

- User Settings

ICUC

The instrument cluster unit is comprised of six physical gauges, indicator lamps (telltails), a six inch portrait driver display screen, steering wheel mounted switches, and audible warning systems. Warning and indicator lamps illuminate in red (warning), amber (caution), green (status on), or blue (informational).

The driver display screen provides information on various vehicle systems as well as warnings, cautions, and notifications on systems status.

4.01.02 Ignition Sequence

When the ignition is turned on, the ICU runs a self-check. Observing the ignition sequence is a good way to ensure the ICU is functioning properly.

IMPORTANT: Do not crank the engine until the ICU self-check is complete.

ICUC

NOTE: Air gauges in the ICUC do not complete a sweep of their dials during the ignition sequence.

When the ignition is turned on, the following actions should occur in the ICUC:

- Freightliner and engine logo displays on the driver display until startup is complete
- Speedometer and tachometer complete a full sweep of their dials
- Warning and indicator lamps illuminate, then are extinguished (if not active)
- Audible alert sounds for any active faults
- Active alerts are displayed on the ICUC screen.

If the ICUC receives active fault codes, it displays them one after the other until the ignition is turned off. The alerts are displayed until they are acknowledged. If there are no active faults, the ICUC displays the home screen after the self-check completes.

IMPORTANT: If any red or amber warning and indicator lamps do not illuminate during the ICUC self-check or do not go out (if not active) after the self-check completes, take the vehicle to an authorized Freightliner service facility as soon as possible.

If active faults are present, take the action outlined in "Warnings, Indicators, and Messages" tables in this chapter, then take the vehicle to an authorized Freightliner service facility as soon as possible.

4.01.03 ICUC Screen Navigation

In the ICUC, the driver display screen is broken up into three areas as shown in Fig.32, [ICUC Driver Display](#): a navigable menu at the top of the screen, a static display at the bottom of the screen, and the central display area (with screen indicator dashes to communicate how many display screens are available in the current menu category).

NOTE: To adjust the brightness of ICUC screen go to User Settings.

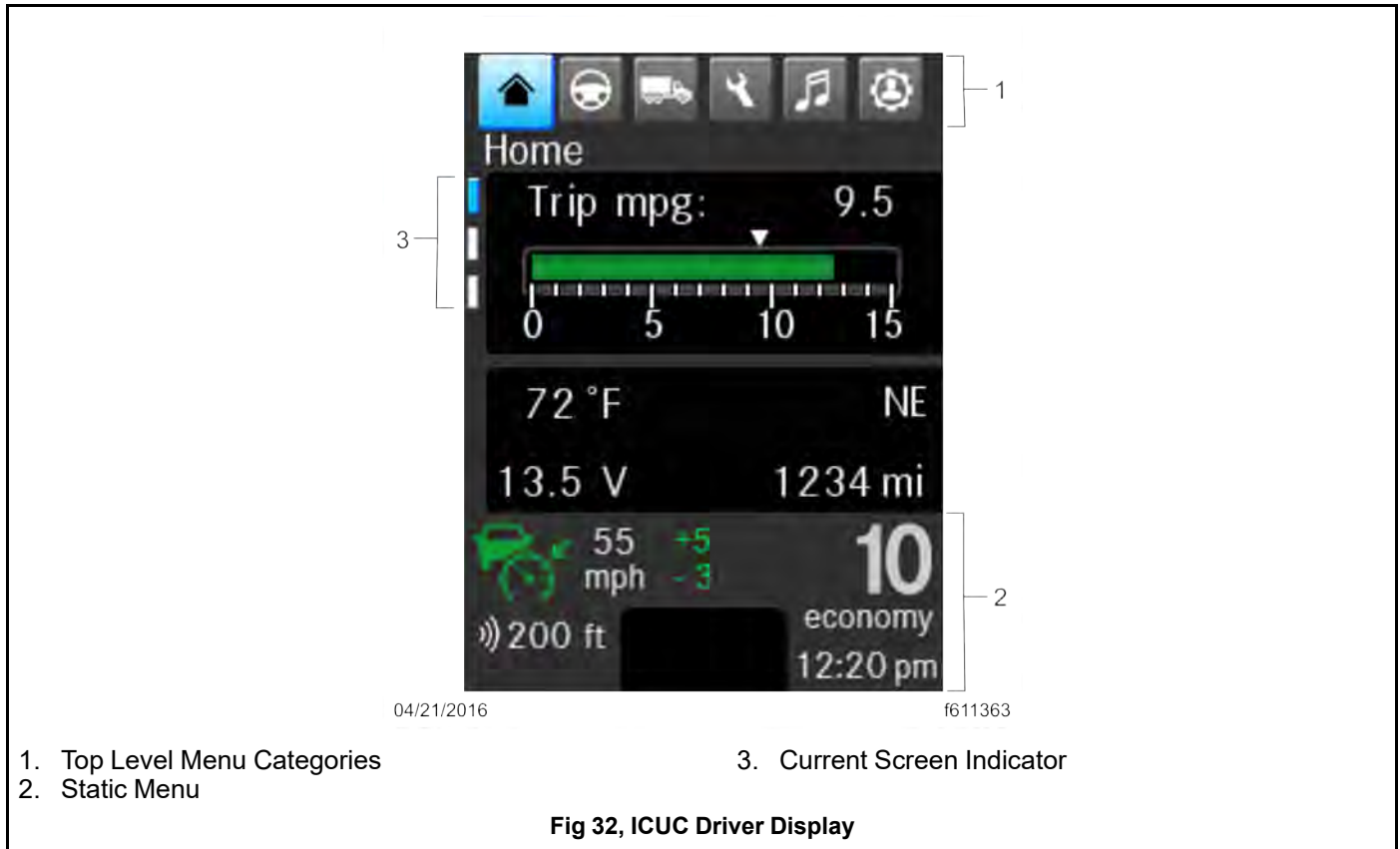

The ICUC top level menu categories, shown in Fig.35, [Instrument Cluster Overview - ICUC](#) allow a driver to quickly carry out common actions. Top level menu categories are Home, Drive Time Systems, Vehicle Operations, Maintenance, Infotainment, and User Settings.

The static menu display at the bottom of the screen, shown in Fig.33, [ICUC Static Display](#) displays the current vehicle speed, transmission gear, cruise control information, a clock, and active telltales.

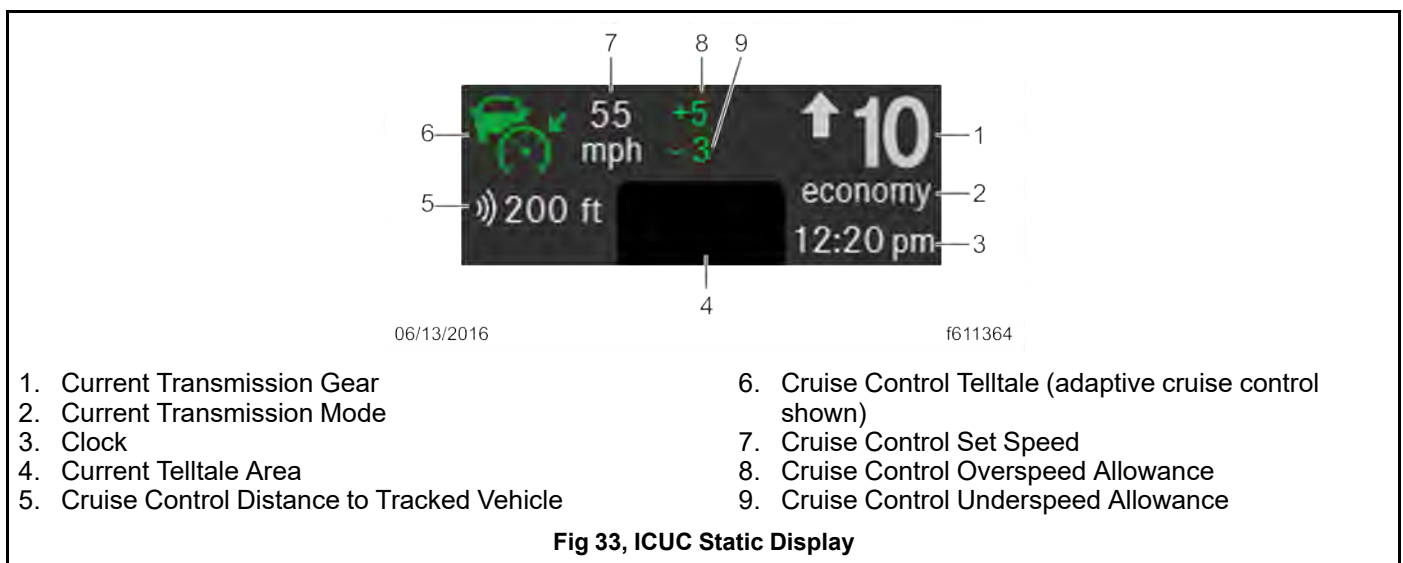

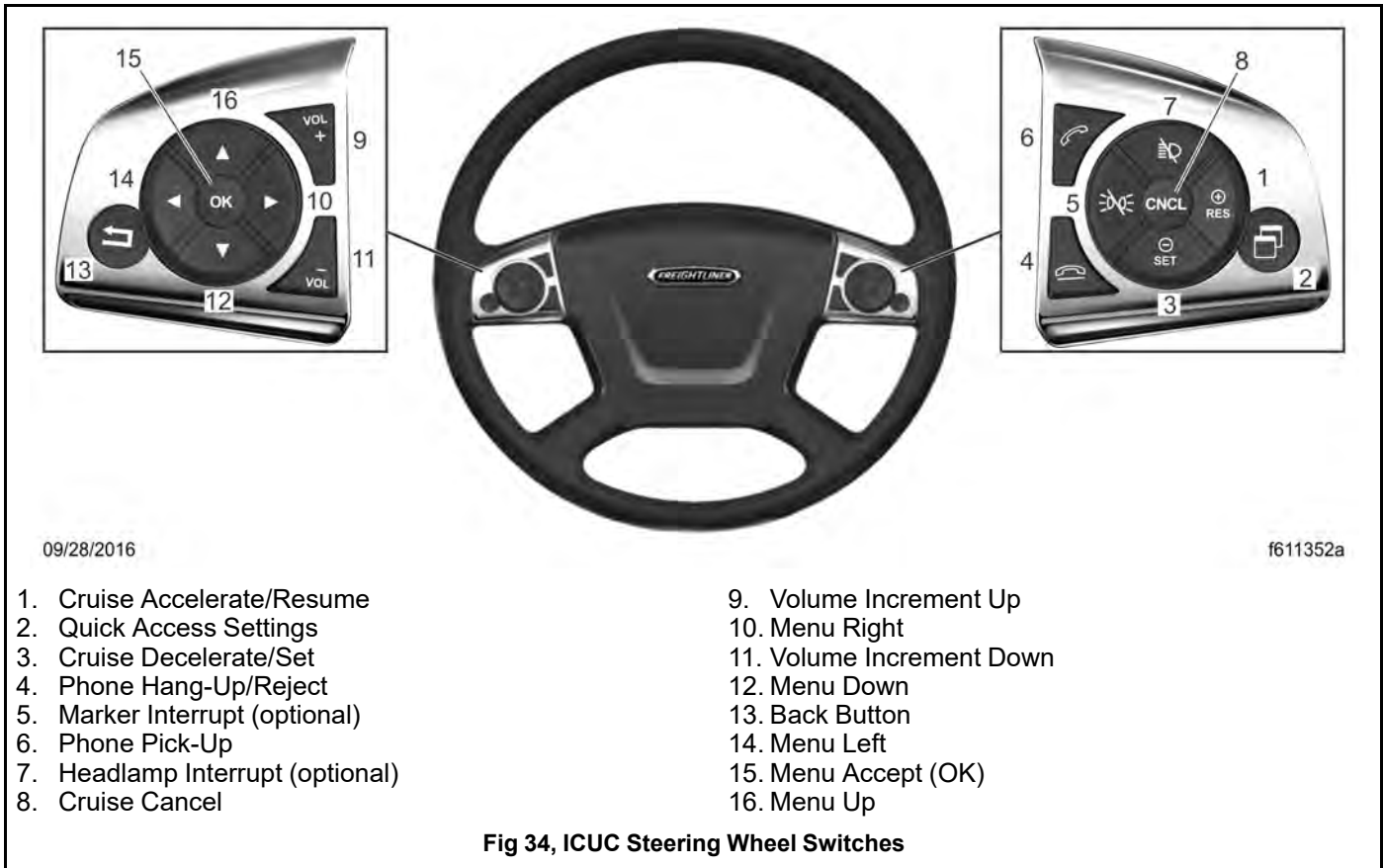

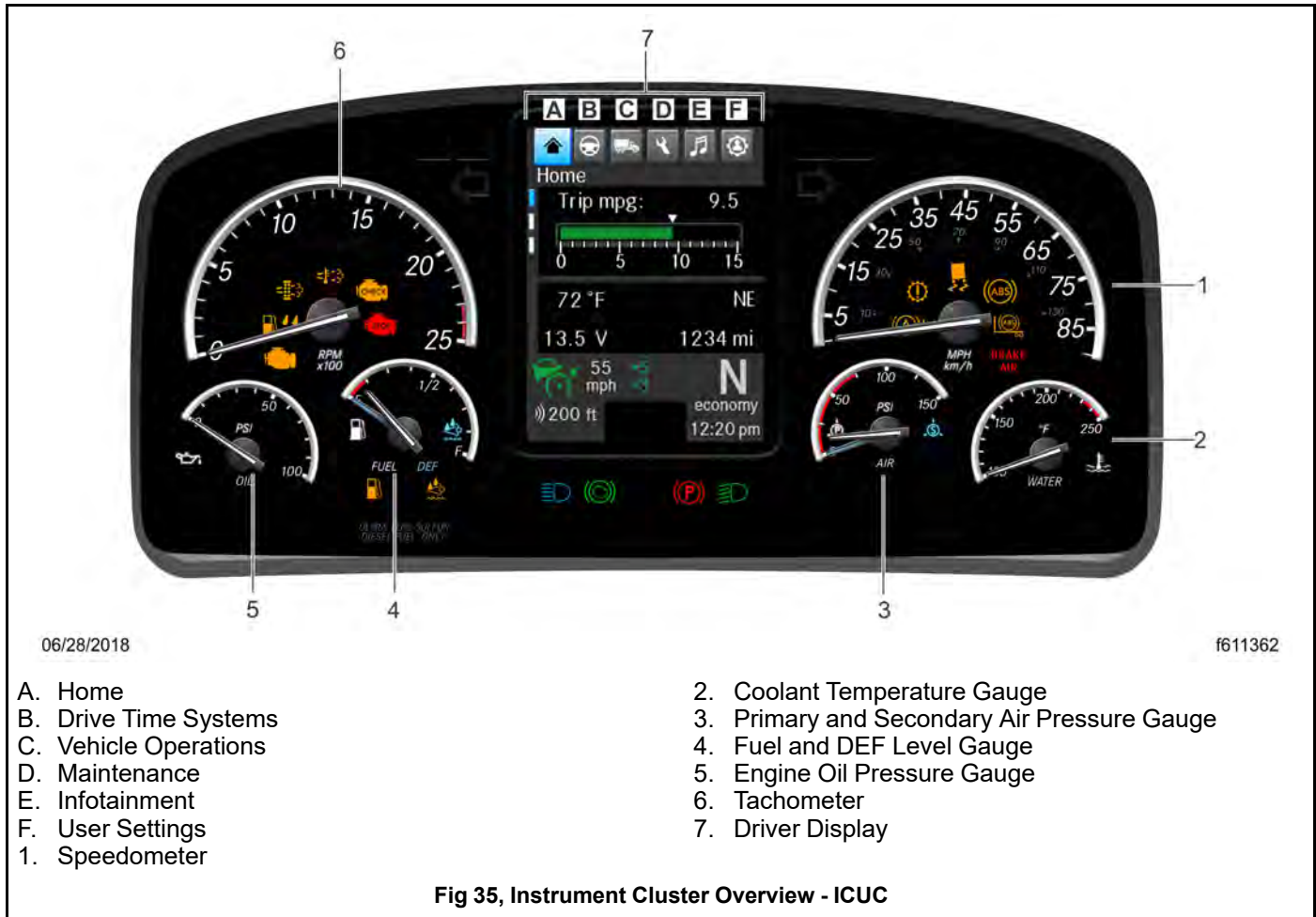

4.01.04 ICUC Steering Wheel Switch Pods

To navigate the ICUC menus, use the 'Menu Right' and 'Menu Left' arrows on the left-hand steering wheel switch pod, shown in Fig.36, [ICUC Steering Wheel Switches](#) to move between the top-level menus. Use the 'Menu Up' and 'Menu Down' buttons to move from screen to screen within the selected category.

For Quick Access Systems menus press the Quick Access System Settings button in the right-hand switch pod. If Quick Access Systems menus are not available, the button will bring up the home screen.

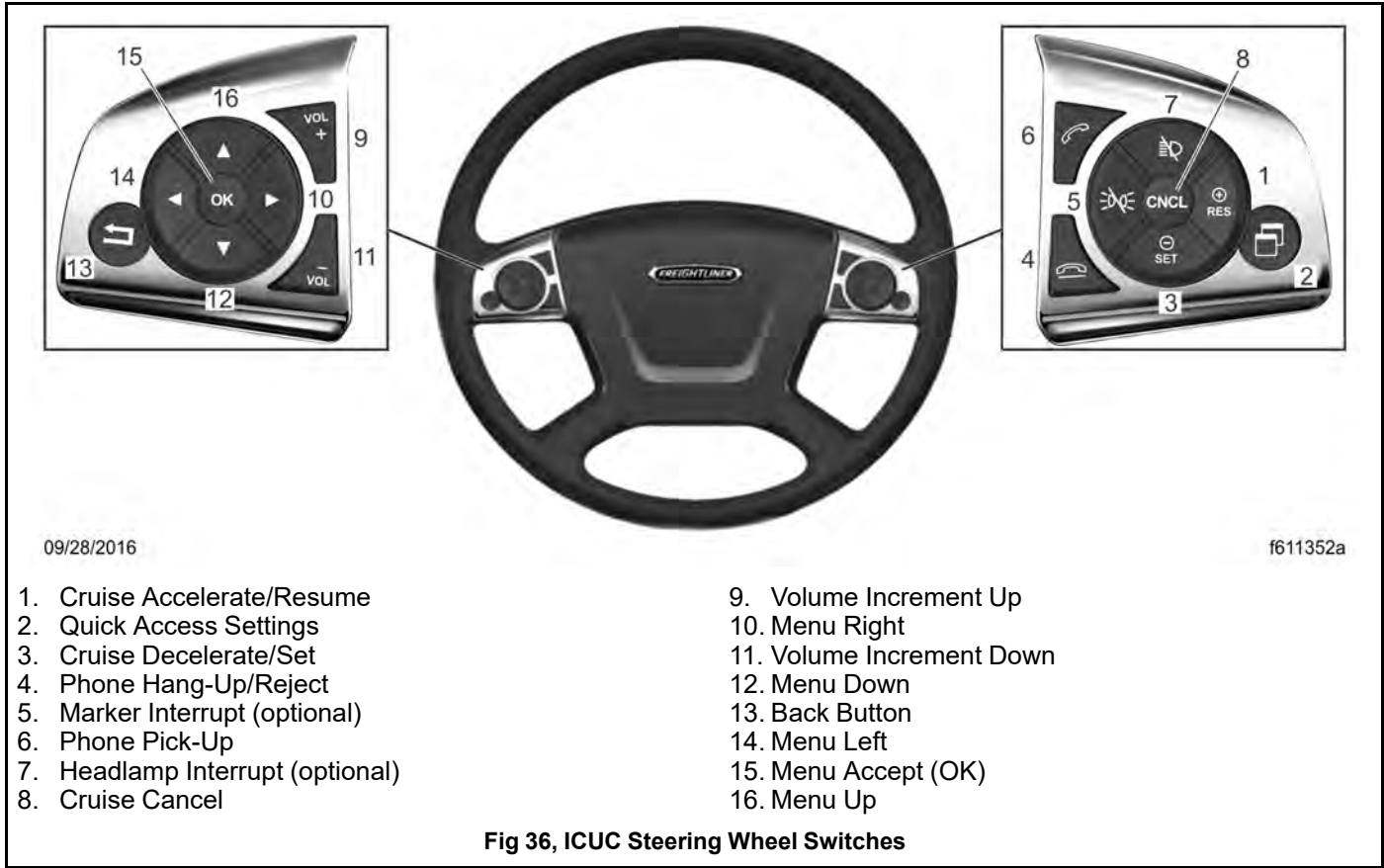

4.02 Driver Display Overview: ICUC

4.02.01 ICUC Alert Messages

Alert messages include warnings, cautions, and notices that require the driver’s attention. The header text and color indicates the priority of the on-screen message, listed from the highest to the lowest:

- Warning (red)
- Caution (amber)
- Informational (blue, green, white, and grey)

Warnings alert the driver to situations or conditions that may pose a threat to control of the vehicle. Follow all instructions given in the message.

Cautions alert the driver to situations or conditions that may result in damage to vehicle components or a derating of engine power.

Informational notices alert the driver to situations or conditions that may affect vehicle performance.

For typical alert messages. See Fig.37, [Sample Alert Messages](#)

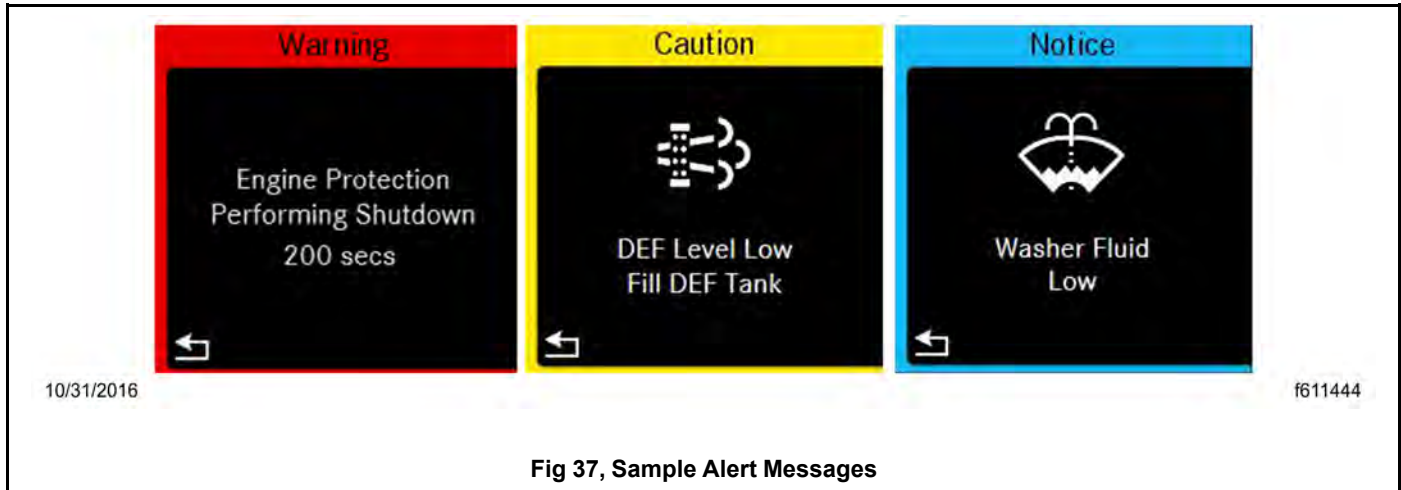

Watch for Ice Alert

When ambient air temperature drops below 34°F (1°C), a Watch For ICE caution, as shown in Fig. 38, [ICUC Watch for Ice Popup](#) will appear. To acknowledge and dismiss the caution message, press the back button in the left-hand steering wheel switch pod. A 34°F (1°C) temperature will also trigger the appearance of a snowflake telltale next to the temperature display. The snowflake telltale will display until the ambient air temperature rises to 37°F (3°C).

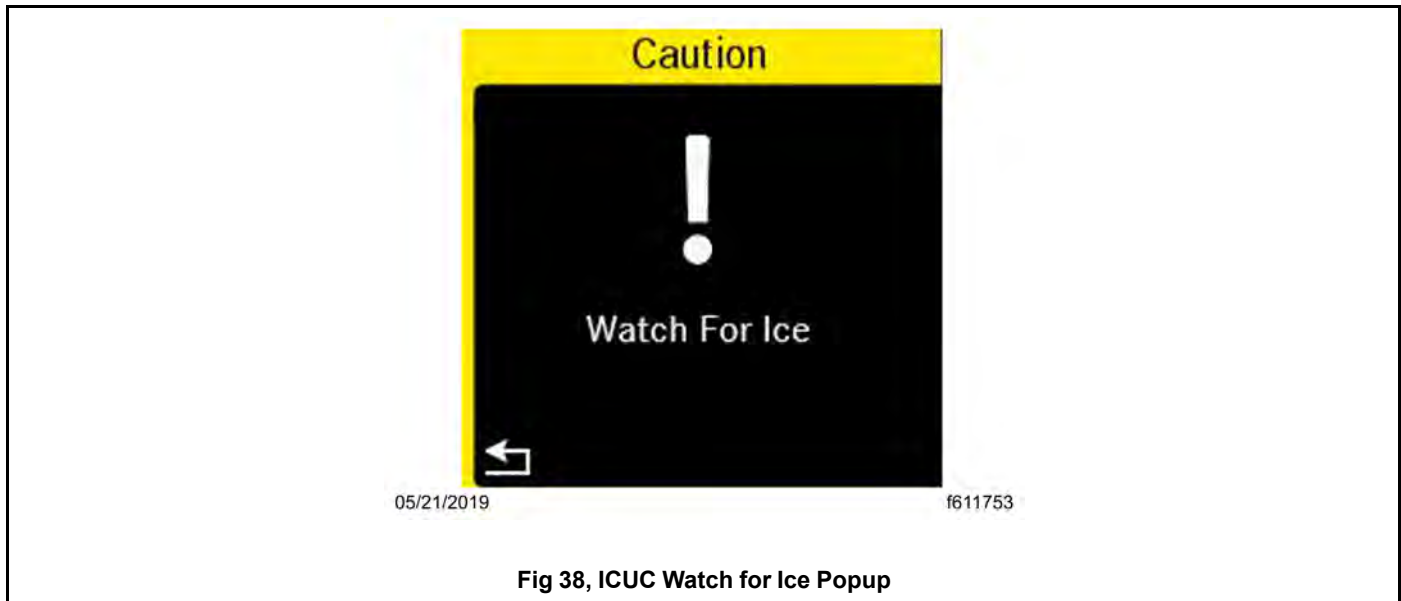

If the temperature drops below 34°F (1°C) after rising above 37°F (3°C), the Watch For ICE popup and snowflake will reappear.

4.02.02 ICUC Time and Alarm Settings

Time and date are set automatically when the vehicle is equipped with a tachograph. When a vehicle is equipped with a tachograph only the time zone can be changed.

The correct time and date is required for the following ICU functions to work:

- alarm clock,

- predictive maintenance intervals,
- prognostics.

4.02.03 Time Settings: Display Format

NOTE: Local time offsets can also be viewed under this menu.

In the ICUC, time can be displayed in 12 or 24 hour format. Time format is set under Time Settings under User Settings.

1. Select the gear icon to open the 'User Settings' menu. The last settings menu accessed will open.
2. If not on the 'Settings Options List' screen, use the up arrow in the left-hand steering wheel switch pod to move to this screen.
3. Press 'OK' to access the settings menus.
4. Use the down arrow in the left-hand steering wheel switch pod to get to 'Time.'
5. Press 'OK' to access Time.
6. Use the right arrow to switch between 12h and 24h.
7. Press 'OK' on the left-hand steering wheel switch pod to choose an option.

4.02.04 Setting An Alarm

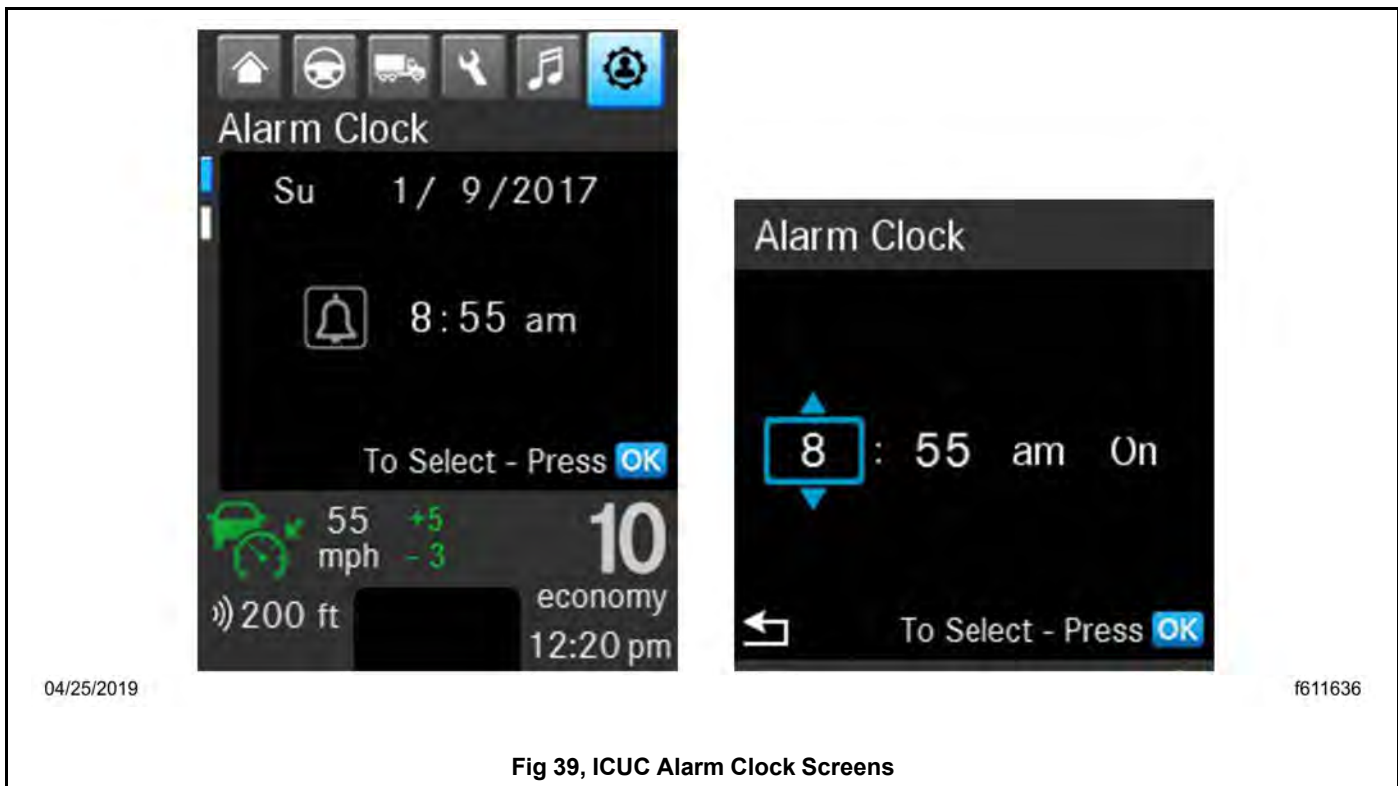

Fig 39, ICUC Alarm Clock Screens

In the ICUC, one alarm can be set under Alarms under the User Settings, as shown in 39, [ICUC Alarm Clock Screens](#).

The alarm triggers a repeated chirping sound as well as a alarm pop-up. Both can be dismissed by pressing the back button on the left hand steering wheel switch pod.

1. Select the gear icon to open the 'User Settings' menu. The last settings menu accessed will open.

2. If not on the 'Alarms' screen, use the down arrow in the left-hand steering wheel switch pod to move to this screen.
3. Press 'OK' to access the alarm clock options.
4. Use the up and down arrow to choose hour, minute, am/pm and alarm status.
5. Press 'OK' to set the alarm.

4.02.05 Main ICUC Driver Display Screens

NOTE: Screens will vary depending on vehicle options. Some screens are accessible only when the vehicle is parked and the parking brake is on.

The main ICUC driver display screens include the splash screen that displays during vehicle start-up and the cruise control settings screen.

The six ICUC top-level menu categories are:

- Home/Basic Information
- Drive Time Systems
- Vehicle Operations
- Maintenance
- Infotainment
- User Settings

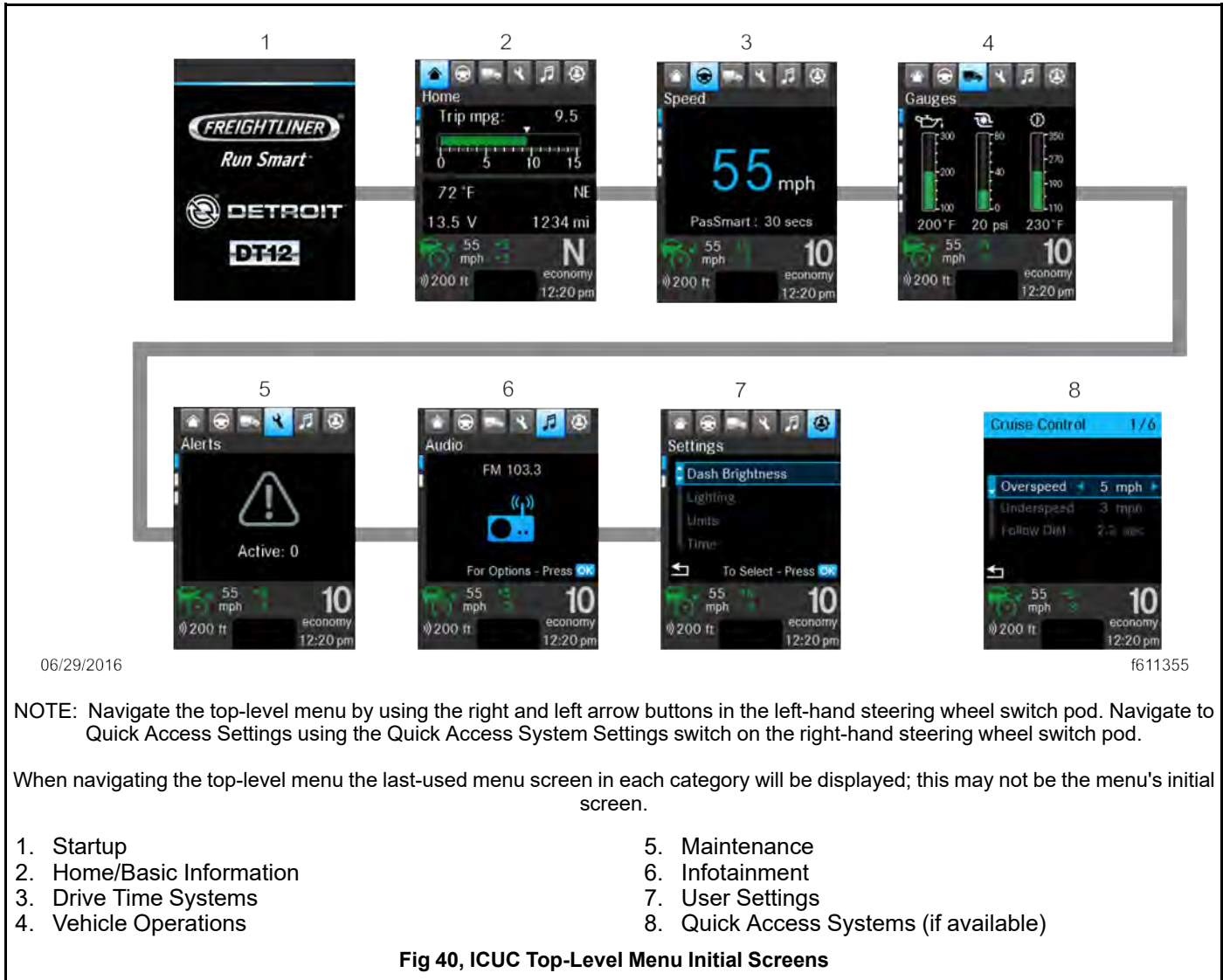

When navigating the top-level menu the last-used menu screen in each category will be displayed; this may not be the menu's initial screen.

Home/Basic Information Screens

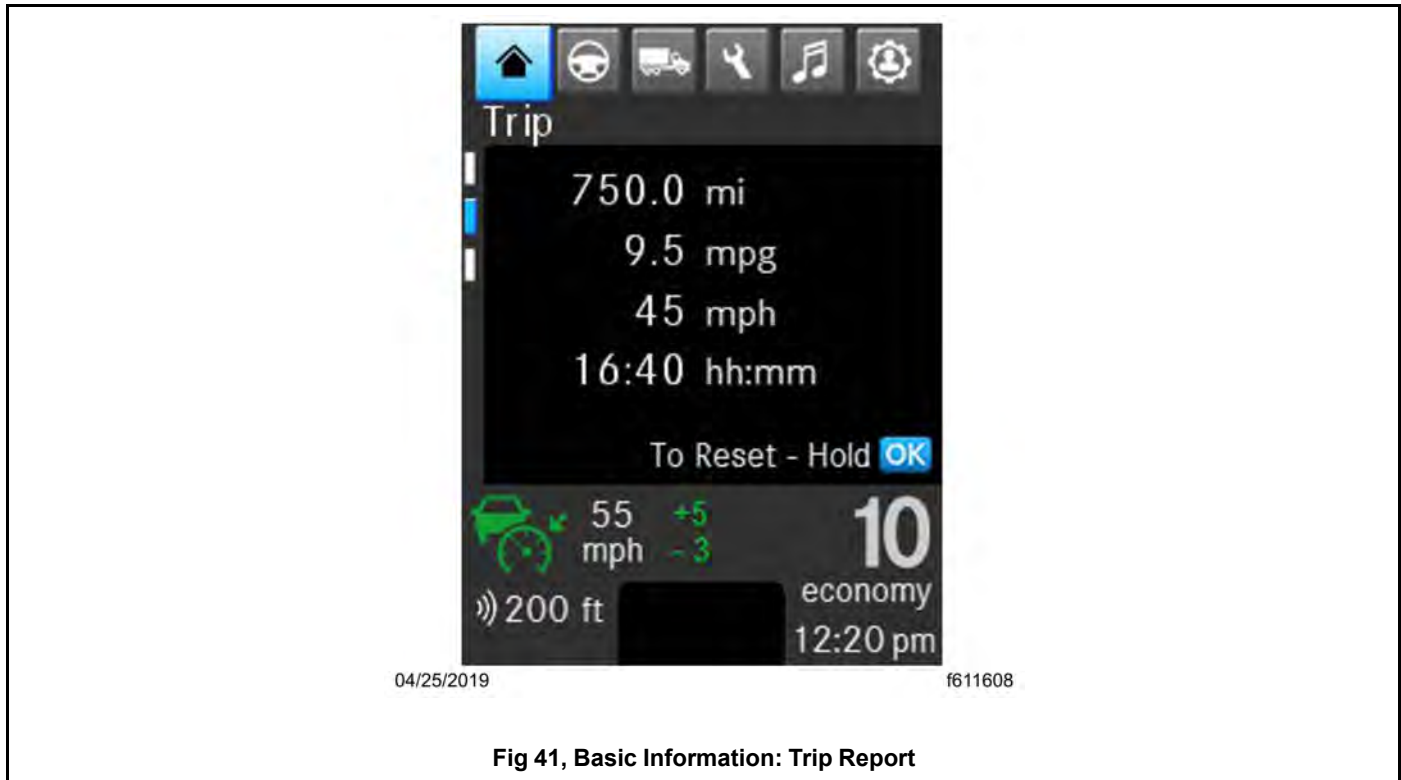

Fig 41, Basic Information: Trip Report

There are three screens under Home/Basic Information:

- Home
- Trip
- Leg

The 'Home' screen displays a fuel consumption bar graph, the current outside temperature, the vehicle charging system voltage, the compass direction of travel, and the current odometer value.

The 'Trip' report screen, shown in Fig.41, [Basic Information: Trip Report](#) displays calculations based on the engine run time such as overall mileage of trip, trip mpg, average mph, and trip time. The 'Leg' report screen does the same for the current leg of the trip. To reset either screen, press and hold the 'OK' switch on the switch pod when on the screen.

Drive Time Systems Screens



Fig 42, Drive Time Systems: Driver Assistance

There are four screen under Drive Time Systems:

- Speed
- Driving Assistance
- Video

The 'Speed' screen, shown in Fig.40, [ICUC Top-Level Menu Initial Screens](#), displays the current vehicle speed and PasSmart information.

Depending on equipment installed, the 'Driving Assistance' screen, shown in Fig. 42, [Drive Time Systems: Driver Assistance](#) displays cruise control information, lane departure information, side guard assist information, and display's the current traffic signs.

Depending on systems installed, video is recorded when active safety systems are engaged or unsafe driving conditions are detected.

Vehicle Operations Screens

There are five possible options under 'Vehicle Operations:'

- Gauges
- Diesel Particulate Filter
- Tire Pressure Monitoring
- Locks
- Vehicle Settings

For information on the display's for gauges and, if equipped, tire pressure monitoring see the "Instruments and Systems" section in this chapter. Information on diesel particulate filter monitoring is covered in chapter, see [14.01 Greenhouse Gas Emissions and Fuel Consumption Standards](#), Emissions. If equipped, information on 'Transmission Prognostics' is covered, see [15.01.01 Direction Switch Automated and Automatic Transmissions](#). For information on Locks see [17.01.01 Drive Axles With Differential Lock](#), Drive Axles.

The Vehicle Settings screen, shown in Fig.43, [Vehicle Operations: Vehicle Settings](#) provides access to settings for vehicle systems such as cruise control, engine idle adjust, and the transmission.



Fig 43, Vehicle Operations: Vehicle Settings

ICUC Maintenance Screens

The maintenance screens are used to retrieve fault codes and other diagnostic and service information pertaining to the vehicle.

There are five menu options under Maintenance:

- Alerts
- Diagnostics
- Engine Maintenance
- Transmission Prognostics
- Maintenance System

The 'Alerts' screen, shown in Fig.44, [Maintenance: Alerts](#) gives access to all active notices, cautions, and warnings.

Fault codes are color-coded to indicate the severity of the fault. Red indicates a condition that may pose a threat to control of the vehicle. Amber indicates a condition that may result in damage to vehicle components or the derating of engine power. Blue, grey, and green are used to indicate information on a component's status.



Fig 44, Maintenance: Alerts

The 'Diagnostics' screen, shown in Fig.45, [Maintenance: Diagnostics](#) display's active diagnostic trouble codes and available software updates.



Fig 45, Maintenance: Diagnostics

The 'Engine Maintenance' screen, shown in Fig.46, [Maintenance: Engine Maintenance](#) displays the current engine hours.

The 'Maintenance System' screens give information about when maintenance is required. See the "Instruments and Systems: ICUC" in this chapter for more details.



ICUC User Settings Screens

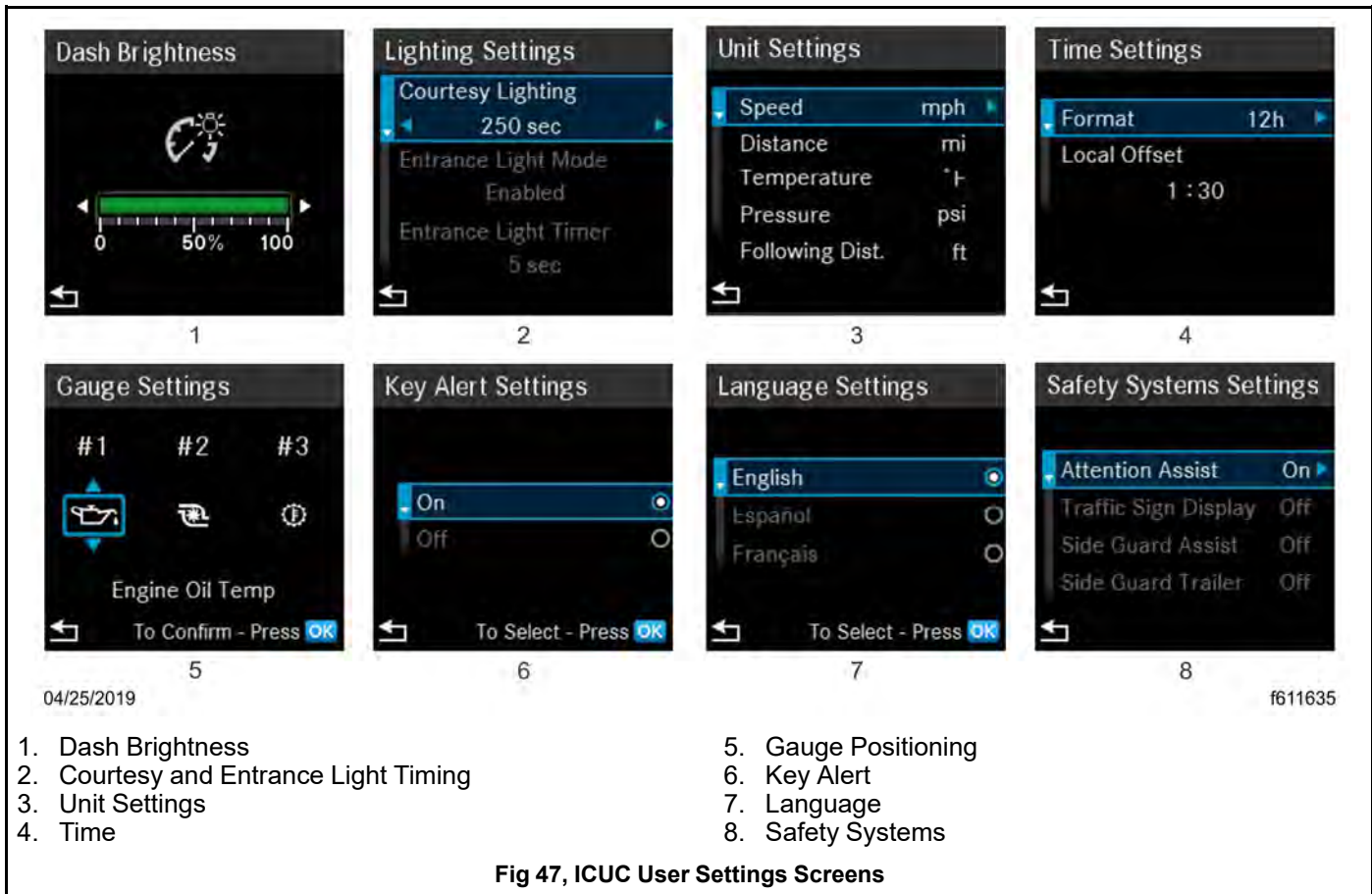

The ICUC Setting Options List screens, shown in Fig.47, [ICUC User Settings Screens](#), allow the driver to choose the following:

- Dash Brightness
- Lighting Settings
- Units Settings
- Time Settings
- Gauge Settings
- Key Alert Settings
- Language Settings
- Safety System Settings

Dash Brightness allows for setting the brightness of the dashboard display.

Lighting Settings controls if the courtesy and entrance lights are on and how long they stay on.

Unit Settings controls the measurement values for speed, distance traveled, temperature, pressure, and following distance.

Time Settings controls the time display format (12h/24h) and local time zone offsets.

Gauge Settings allow the driver to change the order in which gauges are displayed on the gauge screens.

Key Alert Settings control if the key alerts is on or off.

Language Settings allow the driver to set the ICU language to be in either English (American), Spanish (Mexican), or French (Canadian).

Safety System Settings allow the driver to turn safety features such as Attention Assist, Traffic Sign Display, Side Guard Assist, and Side Guard Trailer on or off.

ICUC Quick Access Systems Screens

Quick Access Screens are activated by a button on the right hand steering wheel pod. There are up to six top-level menu options:

- Hysteresis
- Cruise Control
- Transmission
- Engine Idle Adjust
- Power Take Off
- Optimized Idle

Hysteresis allows the driver to set the overspeed and underspeed in mph (km/h). See Fig. 48, [Quick Access Screen: Hysteresis](#).

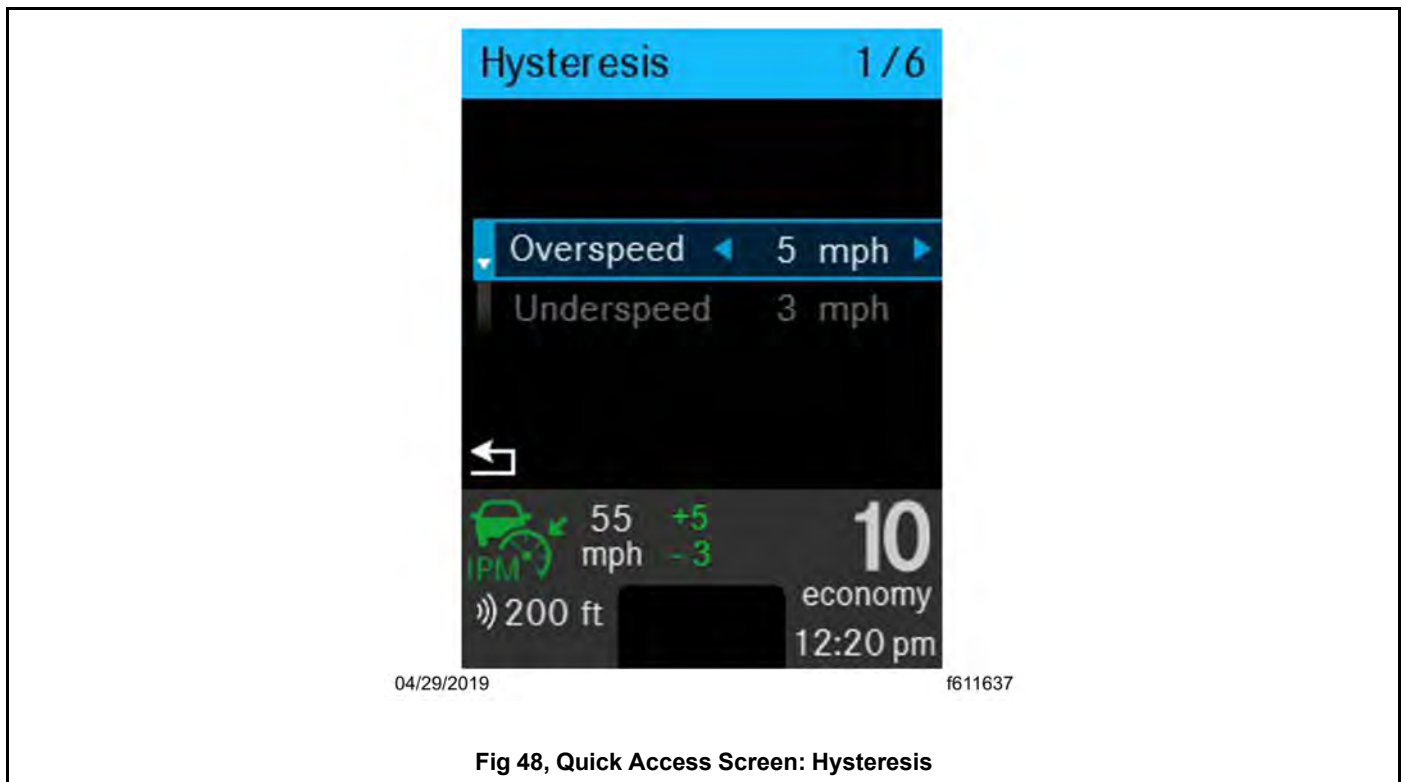

Fig 48, Quick Access Screen: Hysteresis

Cruise Control allows the driver to control such features as active lane assist, lane position, and following distance. See Fig.49, [Quick Access Screen: Cruise Control](#). For more information see "Instruments and Systems: ICUC" in this chapter.

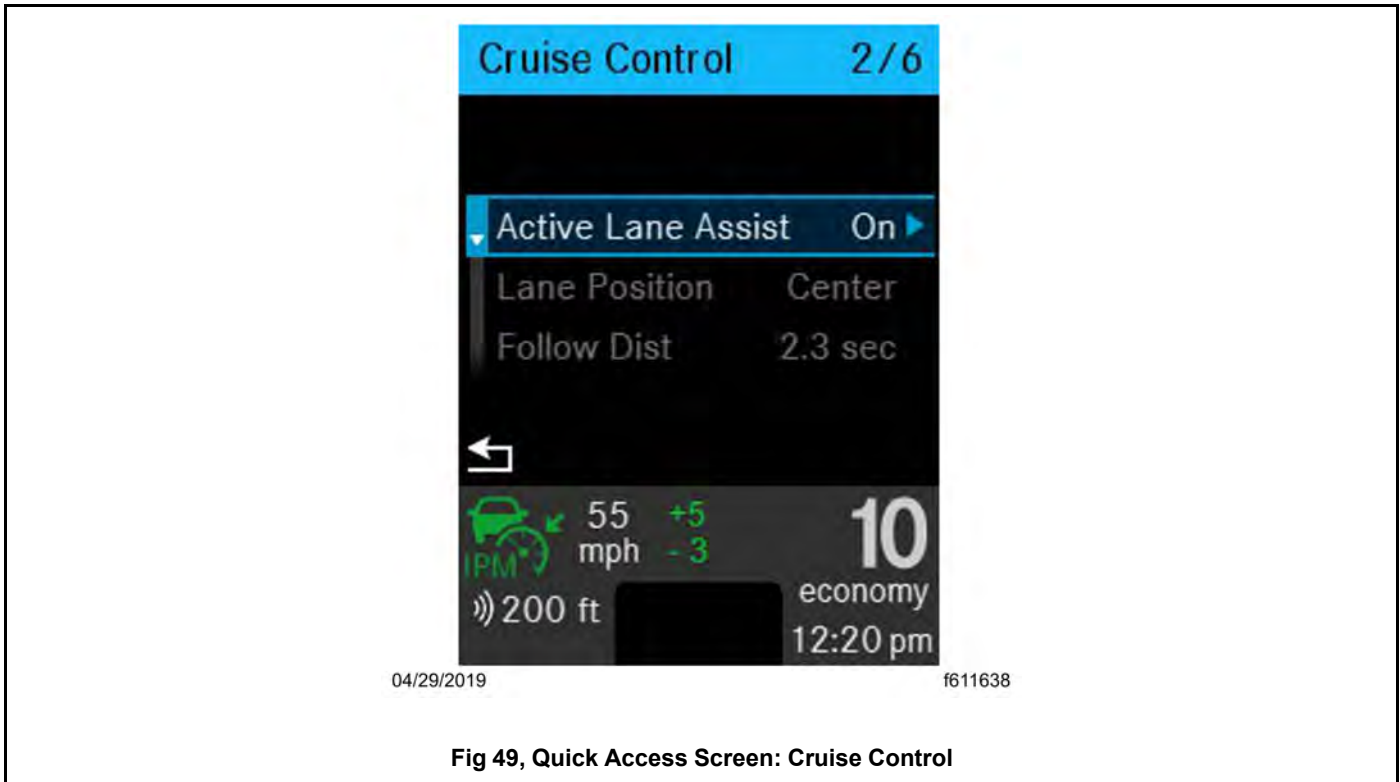

Fig 49, Quick Access Screen: Cruise Control

Transmission allows the driver to turn the creep mode or eCoast feature on or off. See Fig. 50, [Quick Access Screen: Transmission](#). See "Instruments and Systems: ICUC" in this chapter for more information.

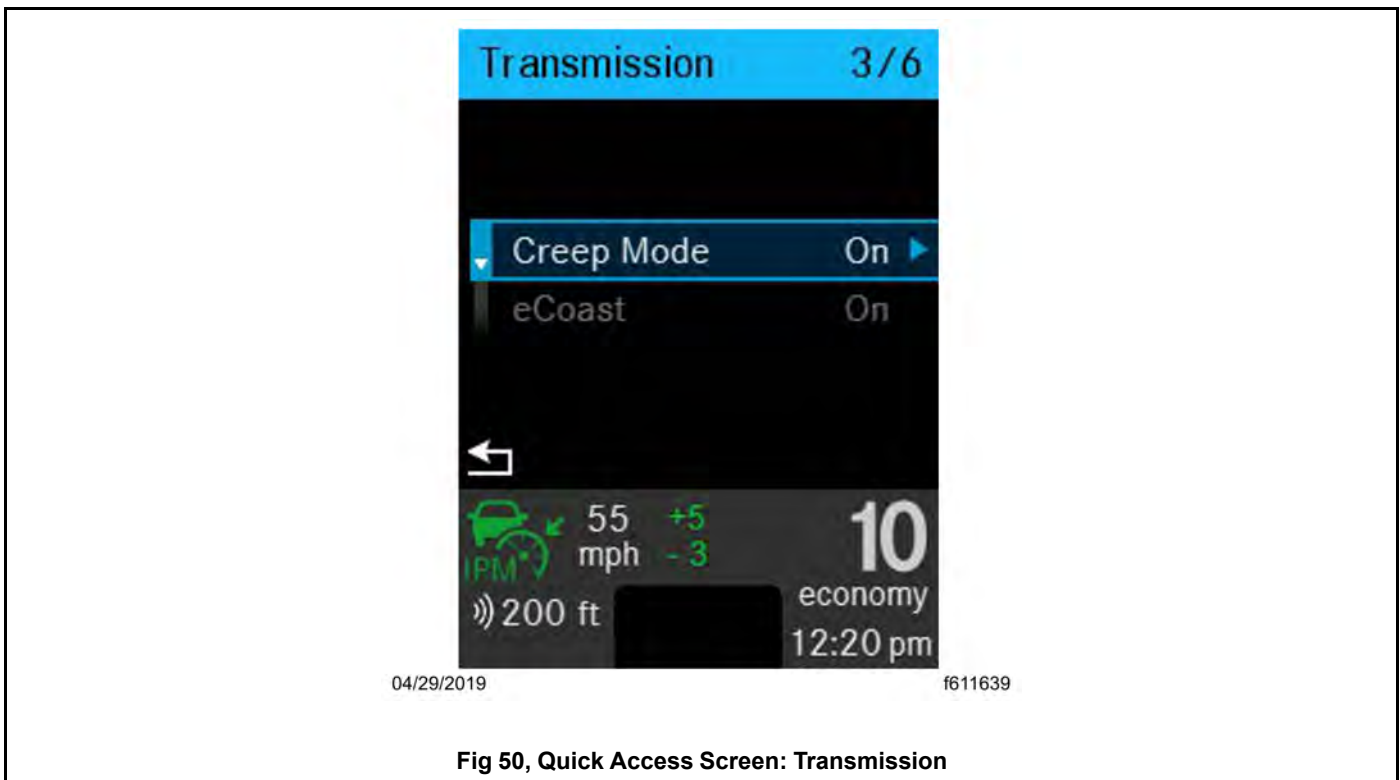
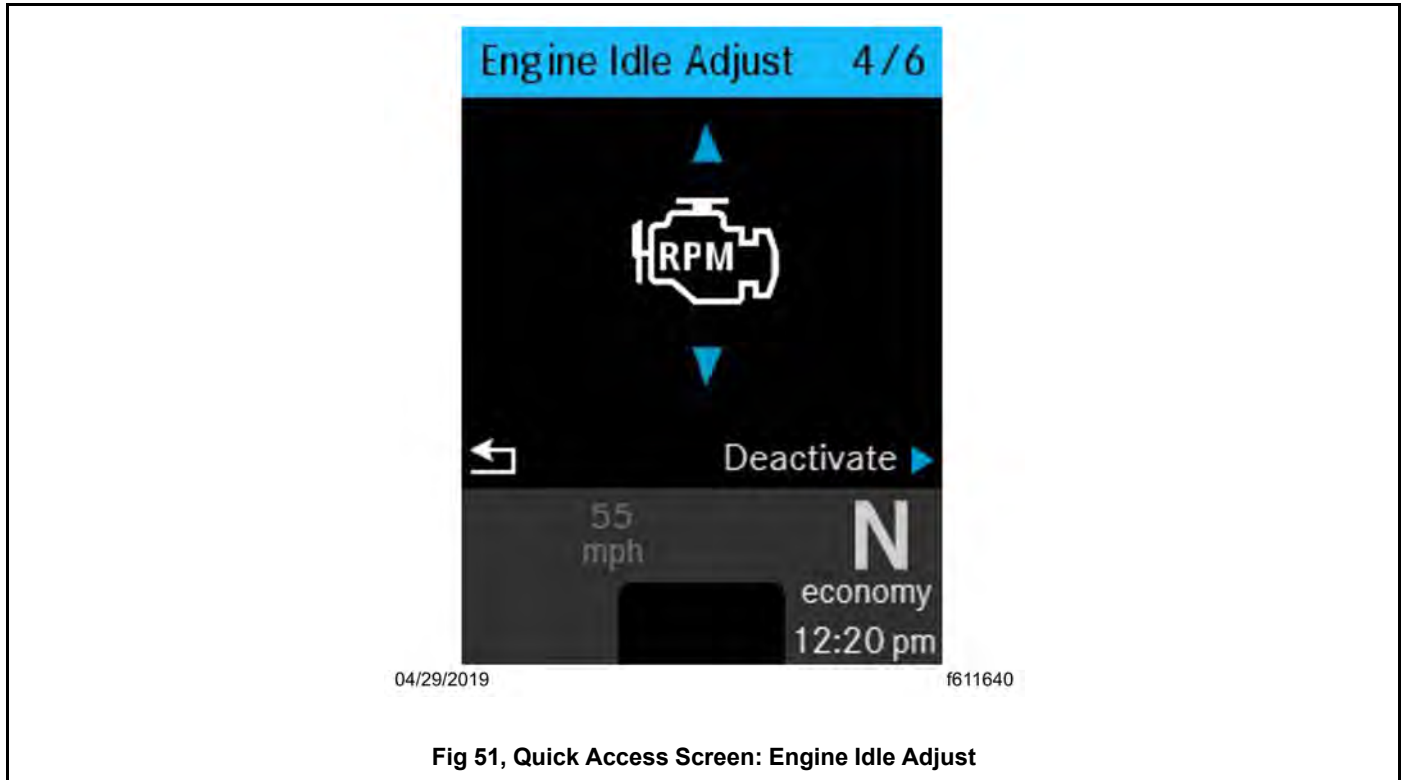

Fig 50, Quick Access Screen: Transmission

Engine Idle Adjust allows the driver to adjust or deactivate the engine idle. It is not available when the vehicle is in motion. See Fig.51, [Quick Access Screen: Engine Idle Adjust](#). For more information see "Instruments and Systems: ICUC" in this chapter.



Power Take Off allows the driver to customize the amount of power being transferred. See Fig. 52, [Quick Access Screen: Power Take Off \(PTO\)](#).

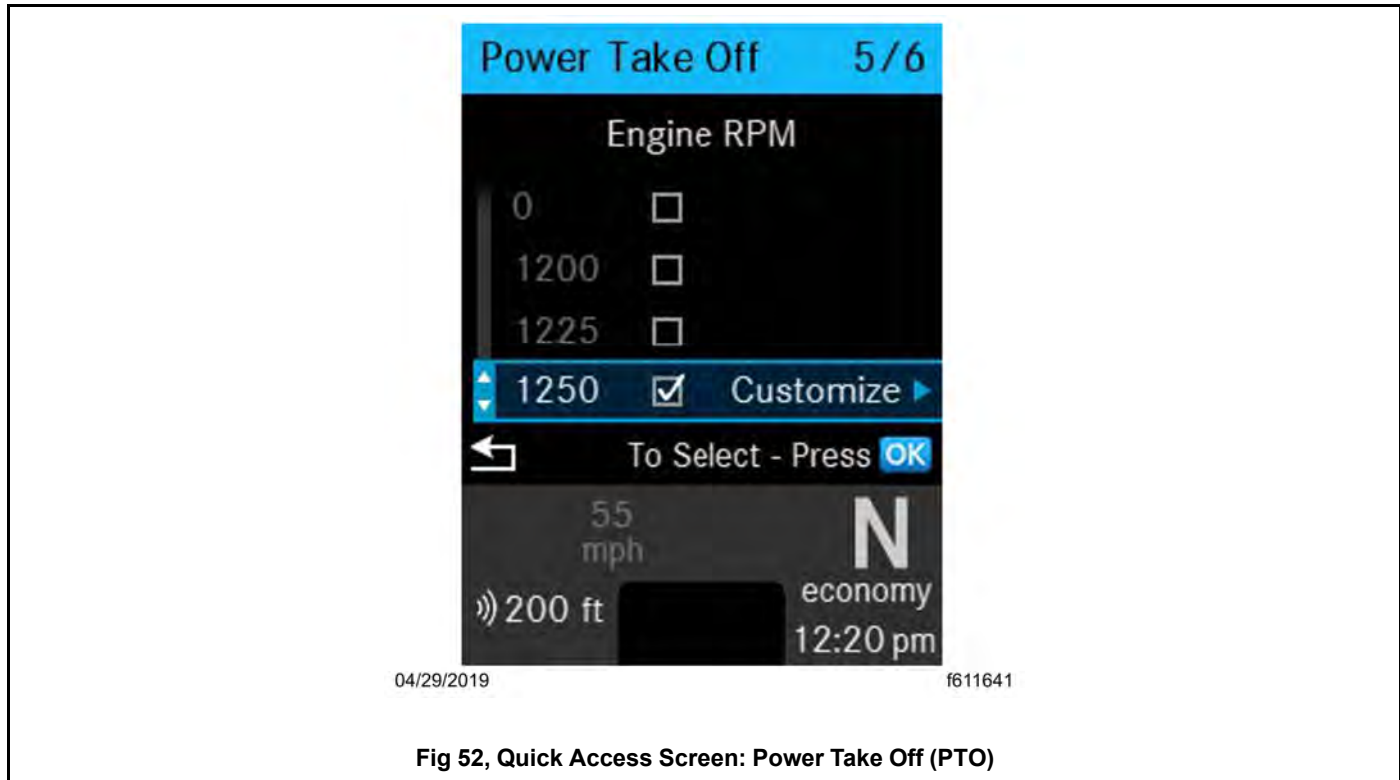

Fig 52, Quick Access Screen: Power Take Off (PTO)

The Optimized Idle screens allow the driver to choose the optimized idle mode and enable or disable the feature. For more information see "Instruments and Systems: ICUC" in this chapter

4.02.06 Software Updates

A software update consists of three steps:

1. Downloading the software.
2. Installing the software.
3. Activating the software by restarting the system.

A popup message will appear when an update is available. In addition, the software update option in the diagnostics menu will be active.

The vehicle must be in neutral gear, the parking brake set, and the engine off before a software update can start. Once started, a software update cannot be cancelled.

During the software update process, progress messages will be provided. See Fig. 53, [Example ICUC Software Update Screens](#) for typical ICUC software update screens.

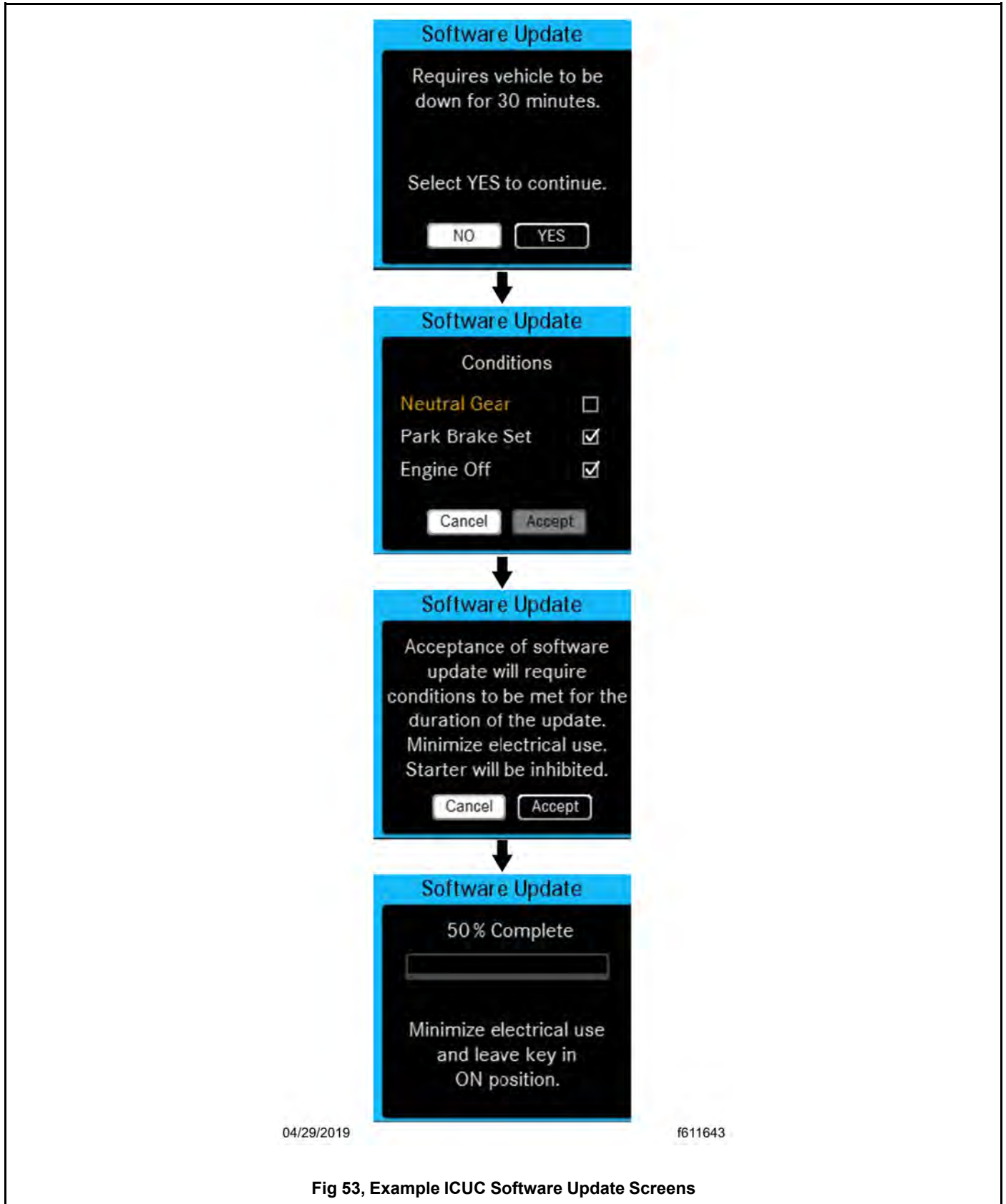

Fig 53, Example ICUC Software Update Screens

If a software update is interrupted, the system will ask if you want to restart the process or inform you that the vehicle cannot be driven until the update is complete. If a software update fails, the system will attempt to revert to the previous version. A notification will appear when a software update has been successfully installed.

Failure to install software updates may make data less secure and/or mean vehicle systems are not operating at their best.

NOTE: An estimation of installation time will be given before the software update starts. Installation can take several minutes. During installation individual functions and controls will not be available or only available to a limited degree.

4.02.07 JVCKENWOOD Interactive Touchscreen Display

This vehicle may be equipped with an interactive touchscreen display from JVCKENWOOD, located on the b-panel.

The JVCKENWOOD Interactive Touchscreen Display can be used to connect a mobile phone to the vehicle through Bluetooth, Android Auto, or Apple CarPlay. It also displays the weather and connects to Radio broadcasting and SiriusXM.

For instructions on how to operate the interactive touchscreen display, use the QR code in Fig.

54, [JVCKENWOOD Interactive Touchscreen Display User Manual](#) or this link: <https://dtna-mud7.jvckenwood.com/>.



4.03 Digital Gauges and System Monitors: ICUC

4.03.01 ICUC Gauges

In the ICUC there are six digital gauges and system screens for the Diesel Particulate Filter (DPF) and Tire Pressure Monitoring System (TPMS).

The six digital gauges under the Vehicle Operations menu of the driver display are:

- Engine Oil Temperature

- Turbo Boost Pressure
- Transmission Oil Temperature
- Front Axle Oil Temperature
- Rear Axle Oil Temperature
- Application Air Pressure

In the ICUC, if a value measured by a digital gauge exceeds the normal range, an amber caution or red danger popup message will appear. However the bar graph color will remain green and the bar graph icons will remain white.

NOTE: The order of ICUC digital gauges and therefore the screen on which they display can be changed under Gauge Settings under Settings.

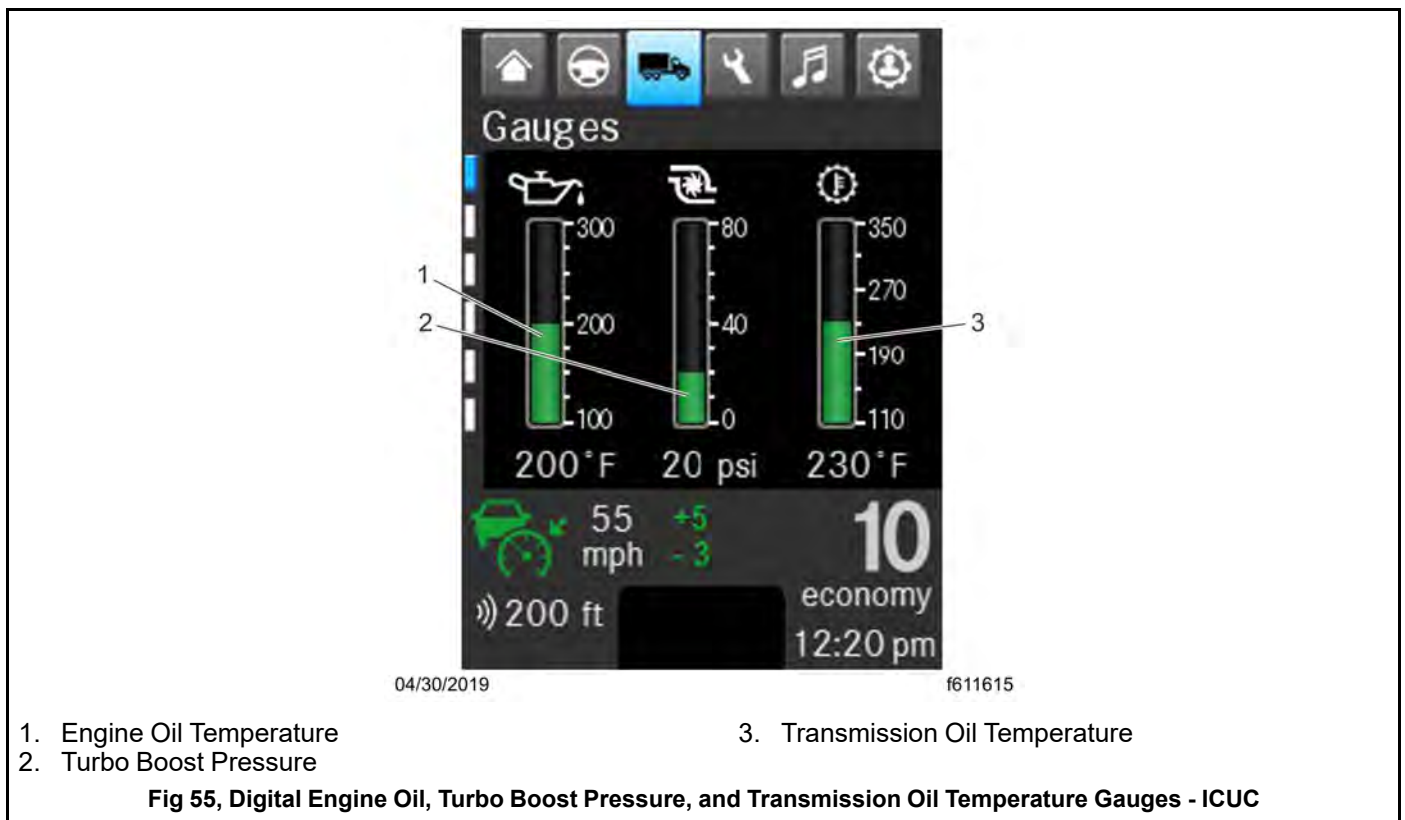

4.03.02 Engine Oil Temperature Gauge



NOTICE:

A sudden increase in oil temperature that is not caused by a load increase may indicate mechanical failure. Bring the vehicle to a safe stop and investigate the cause to prevent further damage. Do not operate the engine until the cause has been determined and corrected.

During normal operation, the optional engine oil temperature gauge, shown in Fig.

57, [Digital Engine Oil, Turbo Boost Pressure, and Transmission Oil Temperature Gauges - ICUC](#), should read in the following temperature range:

- 200 to 260°F (93 to 126°C) for Detroit and Cummins engines

Under heavy loads, such as when climbing steep grades, temperatures that exceed the normal oil temperature range for a short period are not unusual. If the temperature returns to normal when the load decreases, there is no problem.

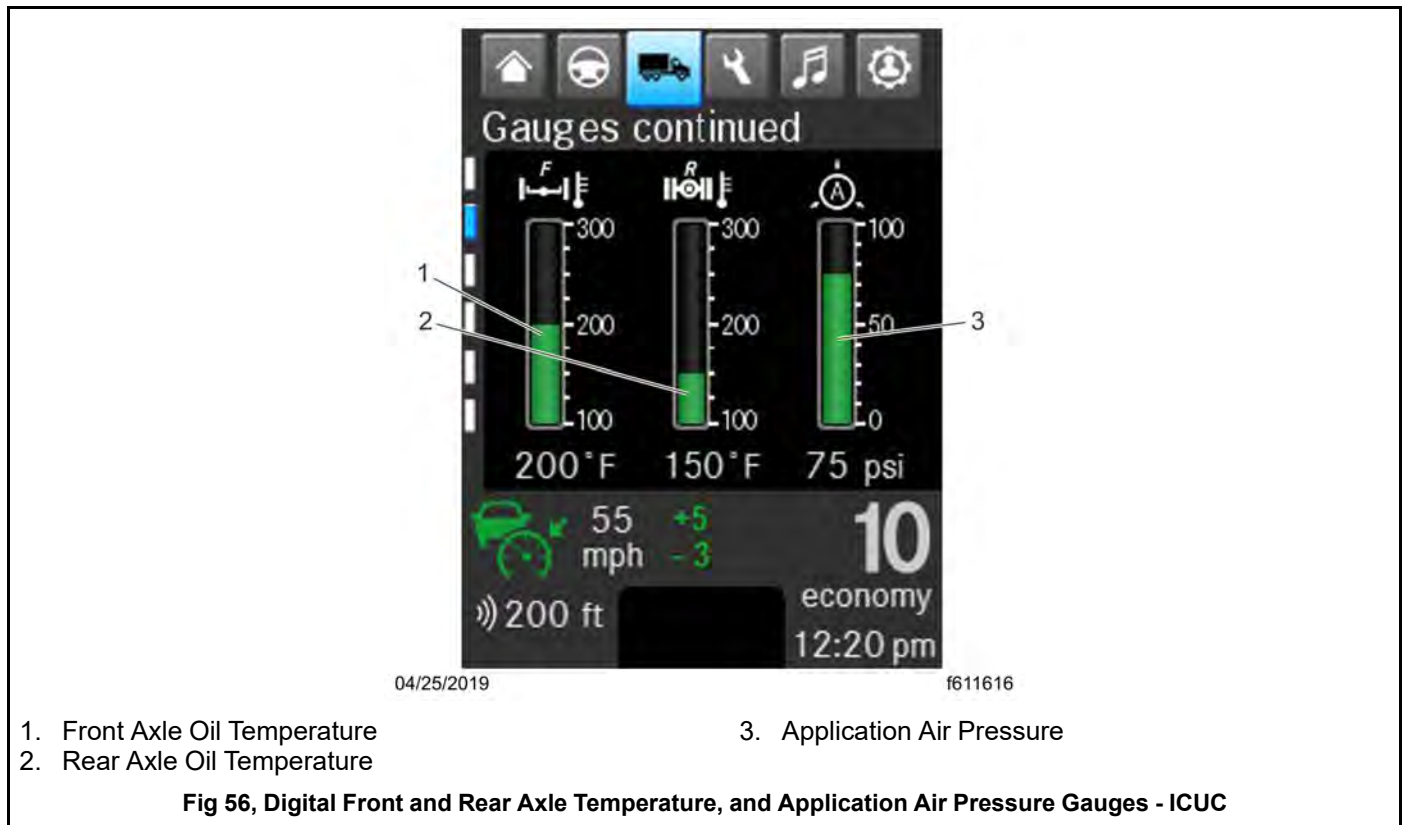

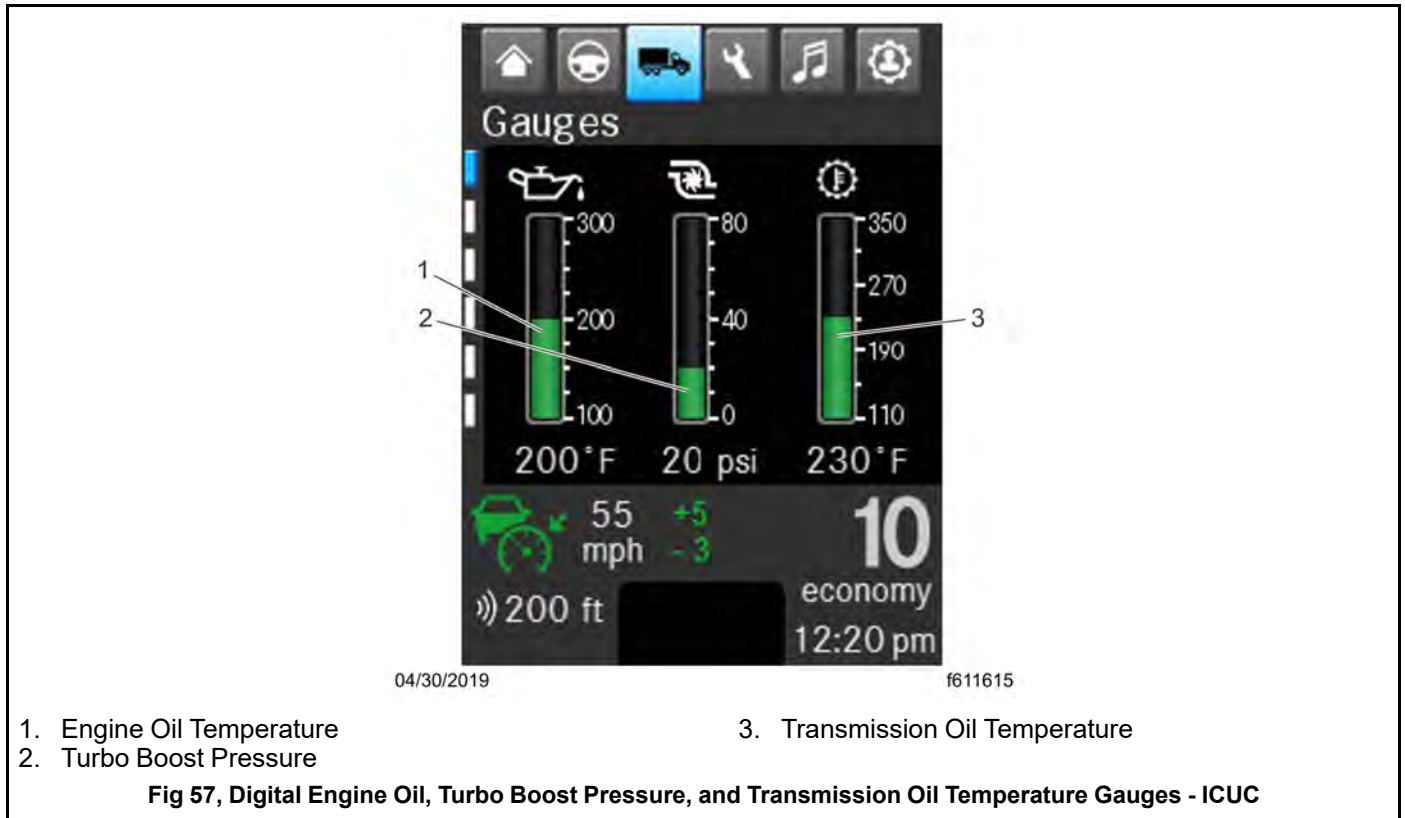

4.03.03 Turbocharger Boost Pressure Gauge

The turbocharger boost pressure gauge, shown in Fig.

58, [Digital Engine Oil, Turbo Boost Pressure, and Transmission Oil Temperature Gauges - ICUC](#), indicates the pressure in the intake manifold, in excess of atmospheric pressure, being created by the turbocharger.

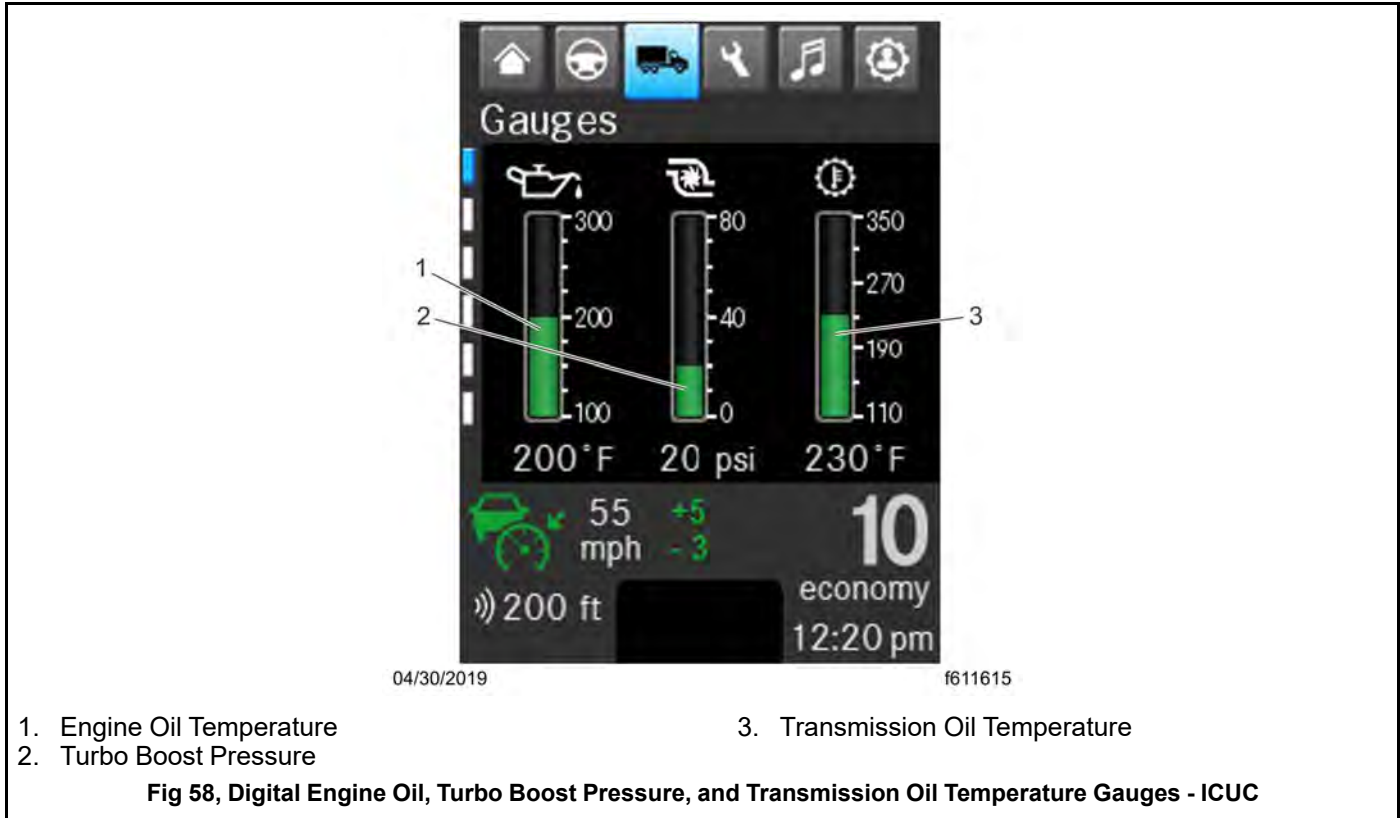

4.03.04 Transmission Oil Temperature Gauge

The transmission oil temperature gauge, shown in Fig.

59, [Digital Engine Oil, Turbo Boost Pressure, and Transmission Oil Temperature Gauges - ICUC](#), measures the transmission lubricant operating temperature. Temperatures vary by application, but the transmission fluid temperature gauge reading should not exceed 250°F (121°C).



NOTICE:

A sudden increase in transmission fluid temperature that is not caused by a load increase may indicate mechanical failure. Bring the vehicle to a safe stop and investigate the cause to prevent further damage. Do not operate the vehicle until the cause has been determined and corrected.

Under heavy loads, such as when climbing steep grades, temperatures that exceed the normal oil temperature range for a short period are not unusual. If the temperature returns to normal when the load decreases, there is no problem.

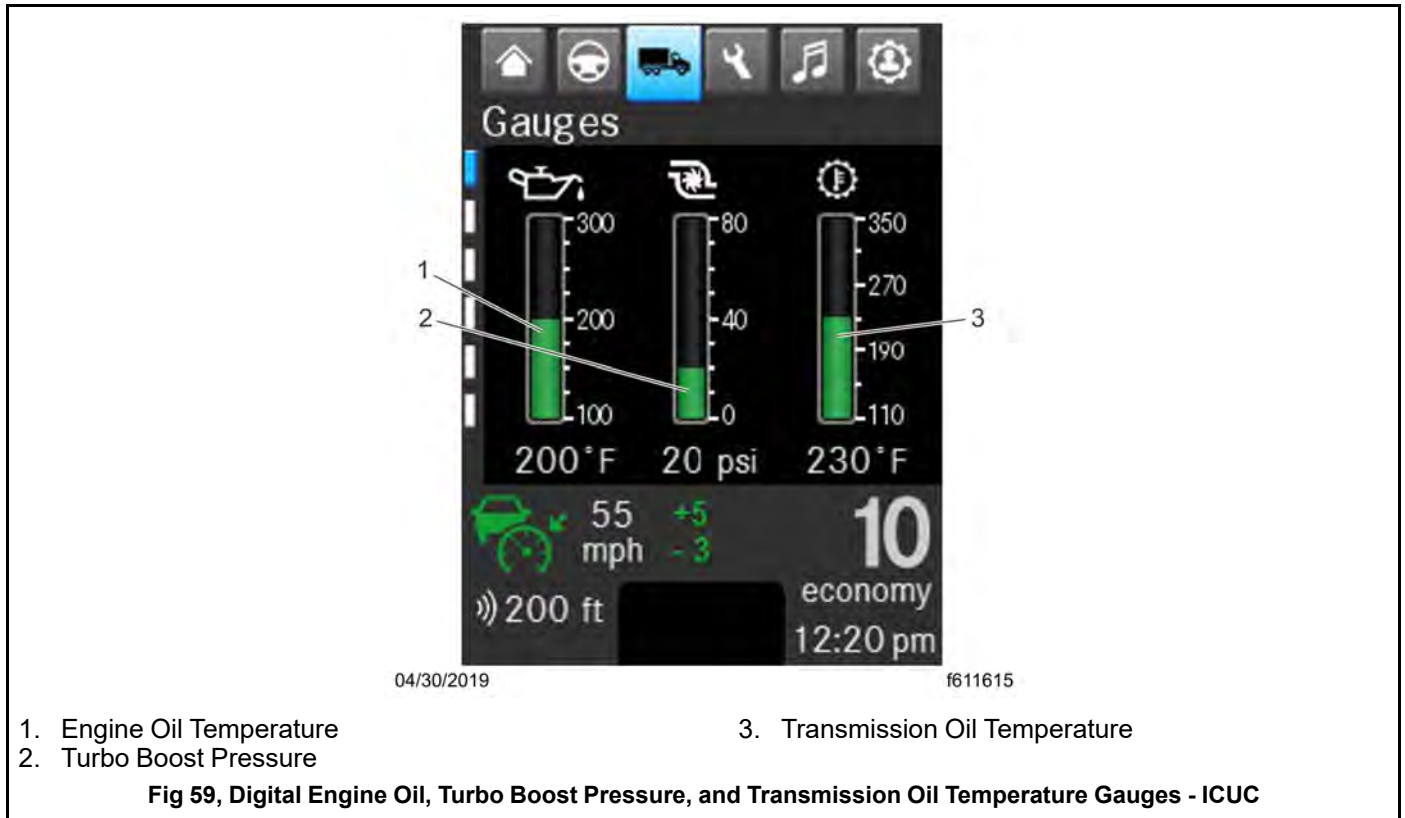

4.03.05 Application Air Pressure Gauge

The application air pressure gauge shown in Fig.

60, [Digital Front and Rear Axle Temperature, and Application Air Pressure Gauges - ICUC](#), registers the air pressure being used to apply the brakes. The gauge will not register air pressure until the foot brake pedal is depressed or the trailer hand brake is applied.

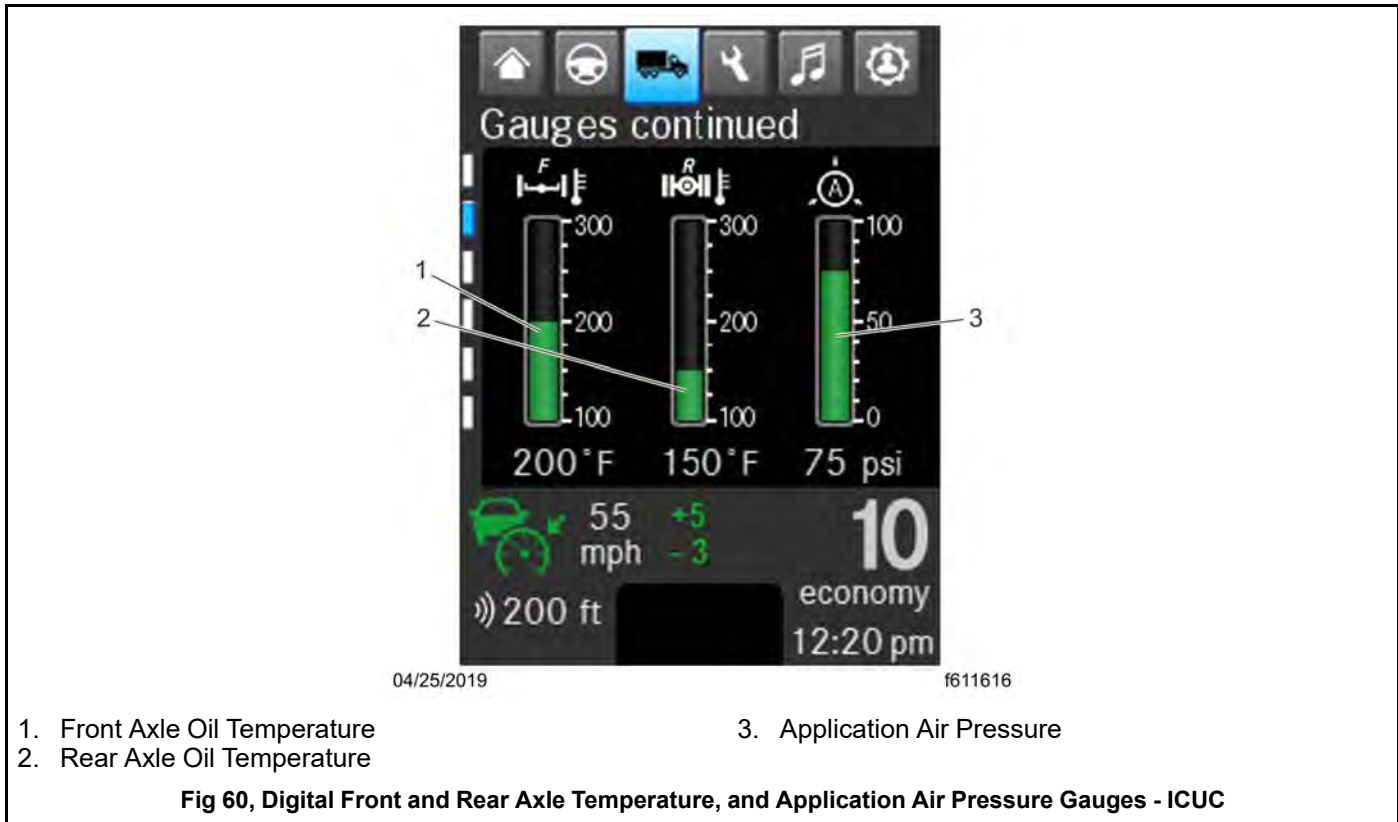

4.03.06 DEF and Diesel Particulate Filter Monitoring

See [14.01 Greenhouse Gas Emissions and Fuel Consumption Standards Emissions](#) for details of Diesel Particulate Filter and DEF level monitoring.

4.03.07 Tire Pressure Monitoring System

The Tire Pressure Monitoring System (TPMS) screens display tire pressure, temperature, and sensor battery status. See Fig.61, [Vehicle Operations: TPMS Axle Tire Pressure, Temperature, and Sensor Status](#). Maintaining correct tire pressure increases fuel economy. Sustained high tire temperature can cause a tire to deteriorate, leading to tread separation and blowouts.

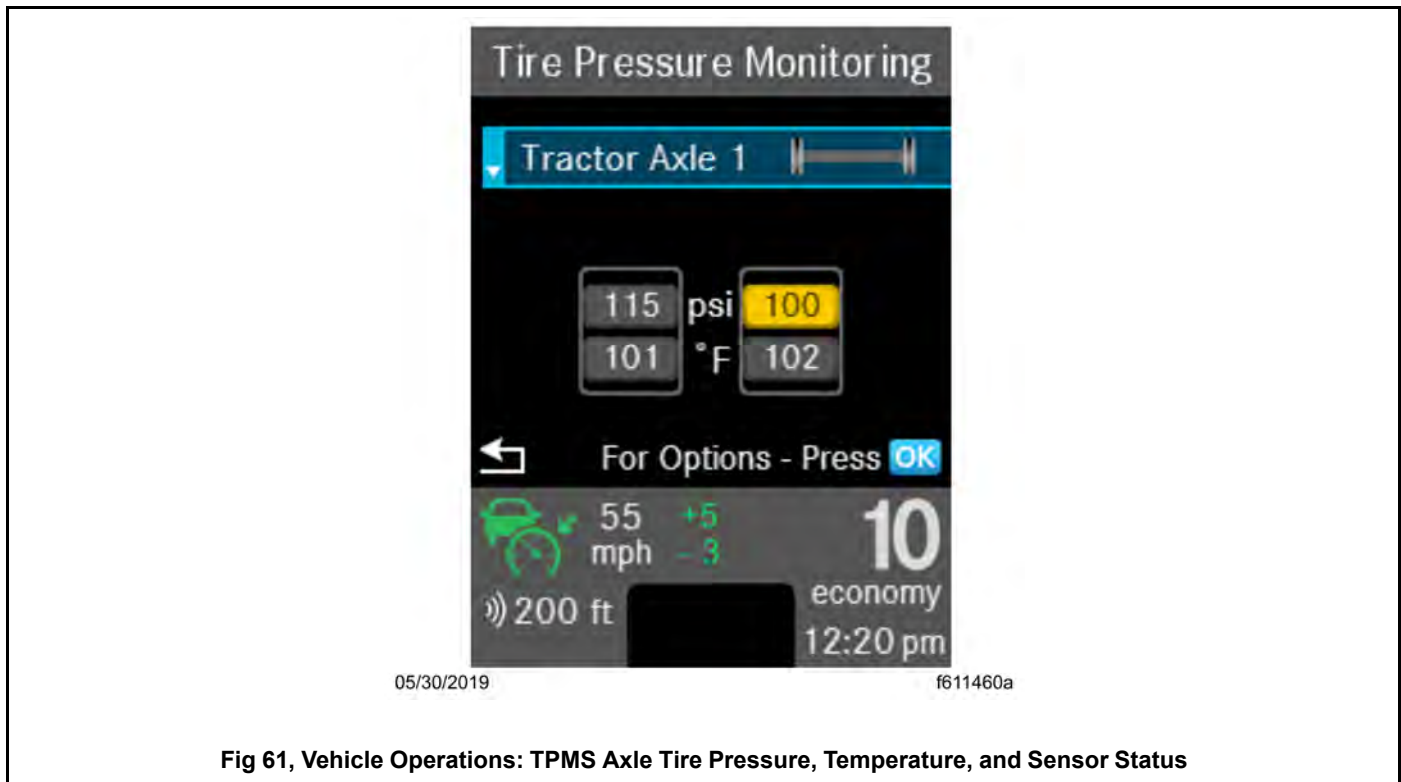

Fig 61, Vehicle Operations: TPMS Axle Tire Pressure, Temperature, and Sensor Status

Tire pressure can be displayed in psi or bar units. Temperature can be displayed in °F or °C. Units of measure are set under Settings. Sensor battery status is displayed as a bar chart inside the outline of a battery.

The TPMS will change the color of the tire on the ICUC screen if the tire pressure or temperature is either too high or too low. See Fig.61, [Vehicle Operations: TPMS Axle Tire Pressure, Temperature, and Sensor Status](#). It will also change the color of the sensor battery icon if the power levels are too low. Amber indicates a condition that may result in damage. Red indicates a condition that may pose a threat to the vehicle.

Tire pressure monitoring settings are part of the TPMS. Threshold temperatures and what triggers alerts can be set on this screen.

4.03.08 Other ICUC Gauges and Measurements

In addition to the two screens of gauges displayed under the Vehicle Operations menu described above, the ICUC driver display communicates a number of values related to vehicle operations. They are listed in alphabetical order below.

4.03.09 Alerts

The Alerts screen stores the current active alerts.

Alerts are color-coded to indicate severity. Red indicates a condition that may pose a threat to control of the vehicle. Amber indicates a condition that may result in damage to vehicle components or derating of engine power. Grey is used for notices.

4.03.10 Battery Voltage

The Home screen in the ICU displays the vehicle charging system voltage in the bottom left. By monitoring this number, the driver can stay aware of potential battery charging problems and have them fixed before the batteries discharge enough to create starting difficulties.

The Home screen will normally show approximately 13.7 to 14.1 volts when the engine is running. The voltage of a fully charged battery is 12.7 to 12.8 volts when the engine is off. Battery voltage under 12.0 volts is considered a low battery, and a completely discharged battery will produce only about 11.0 volts.

If the Home screen shows an undercharged or overcharged condition for an extended period, have the charging system and batteries checked at an authorized Freightliner service facility.

4.03.11 Diagnostics

The Diagnostics screen communicates fault codes and other diagnostic information about the vehicle.

Fault codes are color-coded to indicate the severity of the fault. Red indicates a condition that may pose a threat to control of the vehicle. Amber indicates a condition that may result in damage to vehicle components or derating of engine power. Grey indicates a condition that may affect fuel efficiency or vehicle handling.

4.03.12 Engine Maintenance

Shows the number of hours the engine has been operating.

4.03.13 Maintenance System

NOTE: the wrench icon is indicative of service, not of something that needs to be fixed.

Standard messaging is based on the number of miles (km) driven or time passed since the last service.

Predictive maintenance information is calculated based on these factors as well as engine and transmission load and oil temperature.

Currently, predictive maintenance information is given for engine oil, transmission oil, and axle oil changes. By taking driving conditions into account, predictive maintenance provides more accurate intervals for fluid changes.

Just before the service interval ends, a message that maintenance is due will appear. See Fig. 62, [Maintenance System Status - ICUC](#).



Fig 62, Maintenance System Status - ICUC

When the service interval is reached, a pop-up notice that maintenance is due will appear with every key cycle.

When the service interval is overdue, the color of the wrench icon on the maintenance screen will change from white to amber and the message will change to Maintenance Overdue. This cautionary pop-up will continue to appear with every key cycle.

Each service interval must be reset in the maintenance system when service is performed to provide for accurate future service intervals and to turn off pop-up messaging.

The reset button for maintenance system screens will not appear until the vehicle has been driven 6.2 miles and the engine has run for fifteen minutes.

Maintenance system information and service recommendations can also be viewed in the Detroit Connect portal. Information on the portal is updated every seven days.

4.03.14 Transmission Prognostics

The transmission prognostics screen is only available for Allison transmissions. It displays information on the transmission health status (oil filter status, oil level, and oil life). If transmission health falls below acceptable limits, a message will pop-up on the driver display.

NOTE: For a valid oil level measurement, the vehicle must be stopped on a level surface with the transmission in neutral (N).

4.03.15 Suspension Air Pressure

The ICUC may display four vehicle air suspension yellow caution alerts.

These include Suspension Lowered and Suspension Raised alerts indicating that the current rear suspension height is either below or above the normal ride height. See Fig.63, [Suspension Lowered Alert - ICUC](#) and see Fig. 64, [Suspension Raised Alert - ICUC](#).



Fig 63, Suspension Lowered Alert - ICUC



Fig 64, Suspension Raised Alert - ICUC

The ECAS Problem Detected alert, shown in Fig.65, [ECAS Problem Detected Alert- ICUC](#), indicates the electronically controlled air suspension system has an active fault.

A flashing Load Transfer alert, as shown in Fig.66, [Load Transfer Alert - ICUC](#), indicates the ECAS system is applying the maximum available vehicle load on the drive axle up to the maximum allowable limit determined by the gross axle weight rating (GAWR). Load transfer mode automatically deactivates when the vehicle reaches 45 mph (72 kmh).

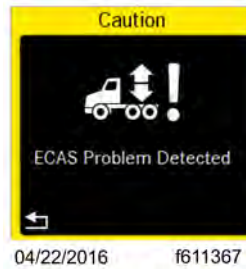

Fig 65, ECAS Problem Detected Alert- ICUC



Fig 66, Load Transfer Alert - ICUC

4.03.16 ICUC Vehicle Operations: Vehicle Settings

The ICUC Vehicle Operations menu has a submenu called Vehicle Settings. Settings and controls for vehicle features installed on the vehicle can be found here. These may include:

- Cruise Control
- Transmission
- Attention Assist
- Engine Idle Adjust
- Optimized Idle

Many of these may also be accessible under the Quick Access Systems menu.

4.03.17 Cruise Control

Settings for cruise control include setting the overspeed and underspeed in mph or kph and setting the following distance in seconds. For full instructions on standard cruise control, see [8.01.01 General Description, Standard Adaptive Cruise Control Driver Assistance Features](#).

4.03.18 Transmission

The Transmission vehicle settings menu allows the driver to turn creep mode and eCoast on or off.

Creep mode is a DT12 Transmission feature that helps the driver move the vehicle at slow speeds by slipping the clutch to reduce torque to the wheels. It is designed to improve maneuverability in situations like parking, docking, and slow traffic.

To activate creep mode for the first time within the current driving cycle, press the accelerator pedal to launch the vehicle, thereby fully engaging the clutch. Stopping the vehicle with the service brake will not cause the vehicle to exit

creep mode. While in creep mode, a lower gear may be selected and the transmission can be upshifted or downshifted with the shifter stalk.

The eCoast feature is standard on DT12 engines. On a downslope the clutch will momentarily disengage so the vehicle maintains momentum while the engine idles. Engine rpms will drop to 600 in eCoast mode. Input from the driver will cause the vehicle to exit eCoast mode.

For a fuller coverage of creep and eCoast mode see [15.01.01 Direction Switch Automated and Automatic Transmissions](#).

4.03.19 Engine Idle Adjust

This feature allows the increase or decrease of the base engine idle speed. Increasing the base engine idle might be necessary to generate enough power to operate accessories.

The following conditions must be met to the engine idle speed to be adjusted:

- Engine is running
- Vehicle is at a standstill
- Transmission is in neutral

4.03.20 Optimized Idle

Optimized Idle reduces idle time by automatically stopping and restarting the engine. Besides saving fuel, it helps keep the batteries charged while maintaining engine and cab temperature.

The following conditions must be met for the optimized idle to function:

- Vehicle in neutral gear
- Park brake set
- Hood latched
- Sleeper fan on

Optimized Idle can be started with the engine running or the engine off.

With the key on, go to Vehicle Settings and scroll down to Optimized Idle. Press OK.

To enable optimized idle, press okay again. A screen will appear saying the default battery mode is on and interior comfort mode is off.

If you want to optimize the environment of the sleeper section, turn on comfort mode. Press the right hand arrow in the left hand switch pod to turn interior comfort mode on and then press OK.

The vehicle will go into standby mode, an under hood alarm will briefly sound, and the engine will crank and achieve 900 rpm. The ICUC screen will then state that it is in interior comfort mode and the engine and air conditioning/fan will run until it achieves the temperature requested by the driver. The engine will then shut down.

Optimized idle can be shut off by ICUC controls or pressing the brake. If the sleeper fan is turned off, optimized idle will not shut down but the engine will.

For a fuller description of Optimized Idle, see [11.01.01 Idle Shutdown Timer Optional Engine Systems](#).

4.04 Infotainment: ICUC

4.04.01 Safety Information

**WARNING:**

There is a risk of distraction from operating integrated communication equipment while the vehicle is in motion.

A driver can be distracted from the traffic situation if operating communication equipment integrated in the vehicle when driving, possibly causing loss of control of the vehicle.

Only operate this equipment when the road and traffic situation permits, otherwise stop and operate the equipment with the vehicle stationary.

The driver must observe the legal requirements of the country the vehicle is driving through when operating the system.

Wearing polarized sunglasses may impair or limit your ability to read the display.

4.04.02 Navigation and Infotainment Reception

Features of both the navigation and infotainment system depend on cellular and satellite reception. In certain situations, such as driving through tunnels, mountains, or parked in multistory parking lots, reception may be impaired due to interference or there may be no reception at all.

4.04.03 General ICUC Infotainment Information

The ICUC infotainment system options consist of:

- AM/FM Radio
- Satellite Radio: SiriusXM®
- Weather Radio
- CD player
- USB & AUX input
- Smart phone Integration

4.04.04 ICUC Infotainment Screens

Use the Menu Up and Menu Down to navigate the infotainment screens:

1. Audio (AM/FM/Weather, SiriusXM, CD, USB, AUX). See Fig.67, [Infotainment: Radio](#).
2. Telephone, showing signal strength, battery level, phone number, and active call length. See Fig. 68, [Infotainment: Active Call](#).



Fig 67, Infotainment: Radio

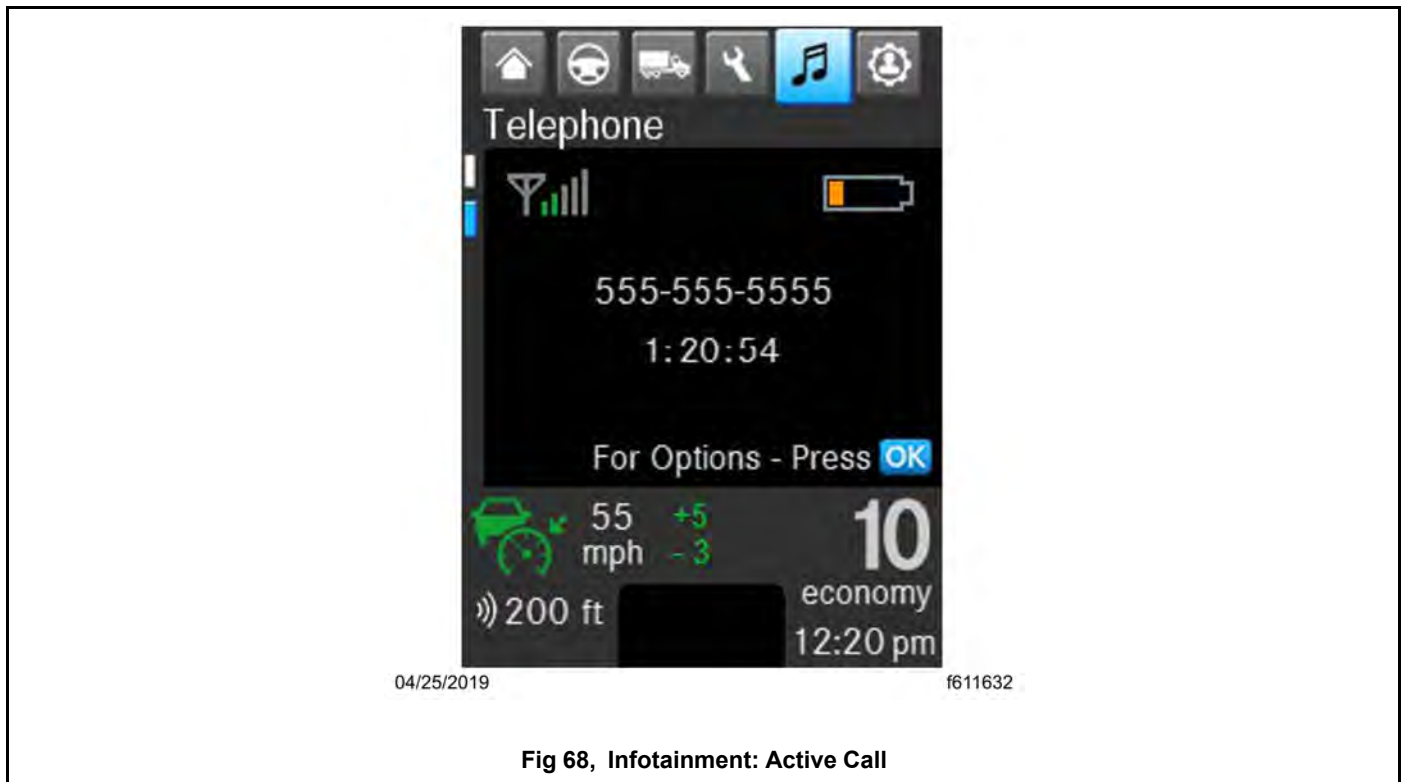

Fig 68, Infotainment: Active Call

4.04.05 ICUC Audio Features

Radio and Other Audio Sources



Fig 69, Infotainment: Radio

Radio stations, presets, and other audio sources can be accessed under Audio.

1. Select the single bar note icon to open the infotainment menu. The last infotainment menu accessed will open.
2. If not on the Audio screen, press the Up arrow in the left-hand steering wheel switch pod to move to this screen.
3. Press OK on the left-hand steering wheel switch pod to access Audio Settings. Press OK on the left-hand steering wheel switch pod to access Audio Settings.
4. Use the Right and Left arrows to navigate from one audio source to another—from radio to USB for example.
5. Use the Up and Down arrows to navigate through an audio options list of choices. Choices can vary depending on the number of audio sources available and saved presets.
6. Press OK on the left-hand steering wheel switch pod to select an audio source. The audio source is selected.
7. Press the Back button to return to the main Audio screen.

4.04.06 Weather Radio (WX)

Weather Radio is an option under Audio.

Weather radio channels WX1 through WX7, corresponding to frequencies 162.400 MHz through 162.550 MHz, are the standard weather radio channels used by NOAA Weather Radio in the United States, Weatheradio Canada/Radiométéo Canada in Canada, and SARMEX in Mexico. Each system consists of a nationwide network of radio stations broadcasting official weather warnings, watches, advisories, forecasts and other non-weather related hazard information including news on natural disasters (earthquakes, avalanches, floods), environmental hazards (oil spills, chemical releases), and public safety messages (AMBER alerts, network outages). All services operate 24 hours a day, 7 days a week.

The average range for reception from a transmitter is approximately 40 miles (60 km). The National Weather Service operates more than 1000 transmitters.

Adjusting the Volume

Volume can be adjusted up using the VOL+ and down using the —VOL switches in the left-hand steering wheel switch pod.

4.04.07 ICUC Telephone Features

Telephone is the second screen under infotainment. The main telephone screen shows the connected phones current signal and battery strength. If a call is in progress it will show the phone number and call length.

Telephone Settings

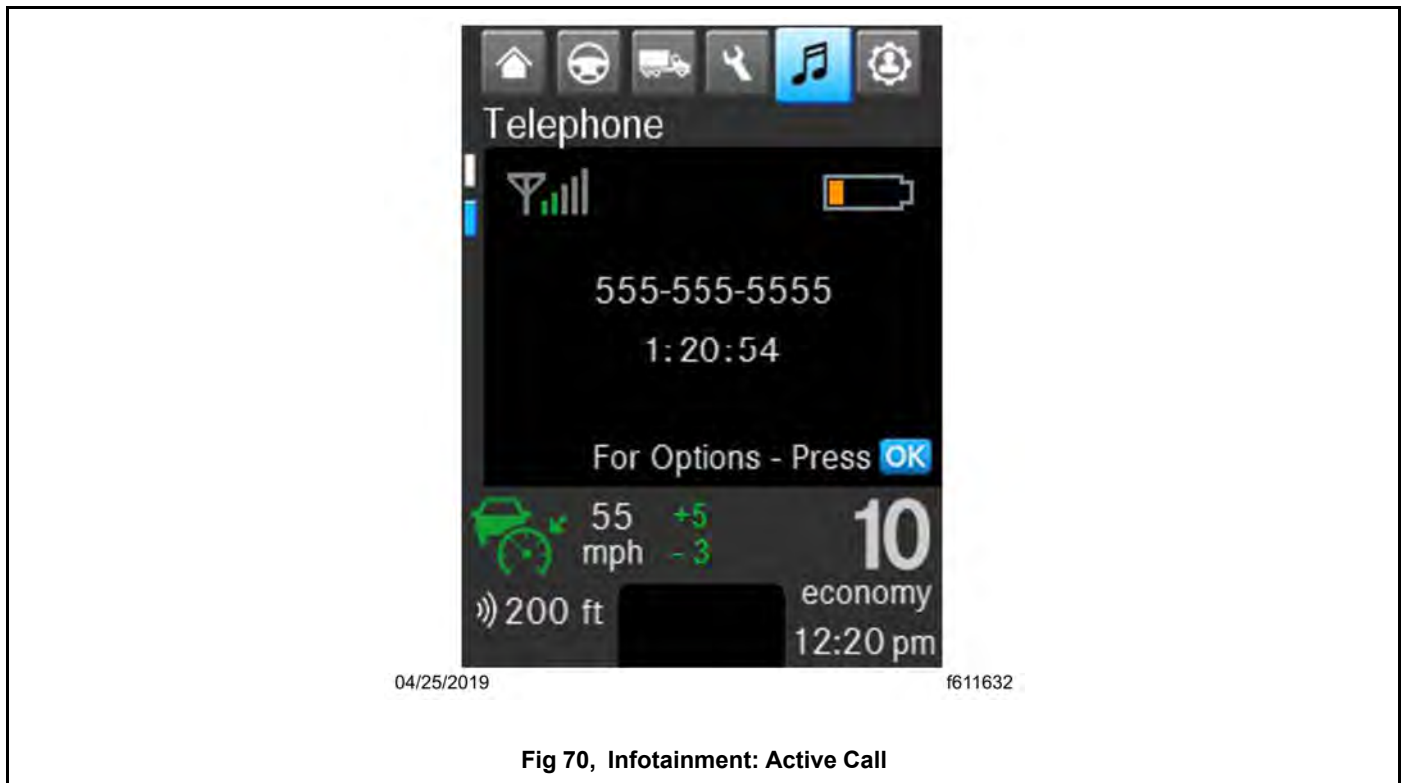

Fig 70, Infotainment: Active Call

Telephone settings displays the phone's call history, contacts, and any contact presets.

1. Select the single bar note icon to open the infotainment menu. The last infotainment menu accessed will open.
2. If not on the Telephone Screen, use the down arrow in the left-hand steering wheel switch pod to move to this screen.
3. When on the Telephone screen, select OK on the left-hand steering wheel switch pod to access Telephone Settings.
4. Use the right and left arrows to navigate from one telephone setting to another—from contacts to missed calls for example.
5. Use the up and down arrows in the left-hand steering wheel switch pod to navigate through the current Telephone Settings list of choices.
6. Press OK on the left-hand steering wheel switch pod to choose an option.
7. Press the back left-hand steering wheel switch pod to return to the main screen.

4.05 Analog Instruments

4.05.01 Air Intake Restriction Gauge

Physical instruments are listed here in alphabetical order. Some are optional and therefore not found in every vehicle. Digital instruments and gauges are described in their ICU section.

The air intake restriction gauge indicates the vacuum on the engine side of the air cleaner. On standard installations, it is mounted on the air intake duct in the engine compartment, and has a go/no-go restriction indicator without graduations. See Fig. 71, [Manual-Reset Air Restriction Indicator, Go/No-Go](#). As an option, a graduated indicator (see Fig. 72, [Air Intake Restriction Indicator, Graduated](#)) on the air intake duct or, for easier viewing, a dash-mounted restriction gauge may be installed.



Fig 71, Manual-Reset Air Restriction Indicator, Go/No-Go

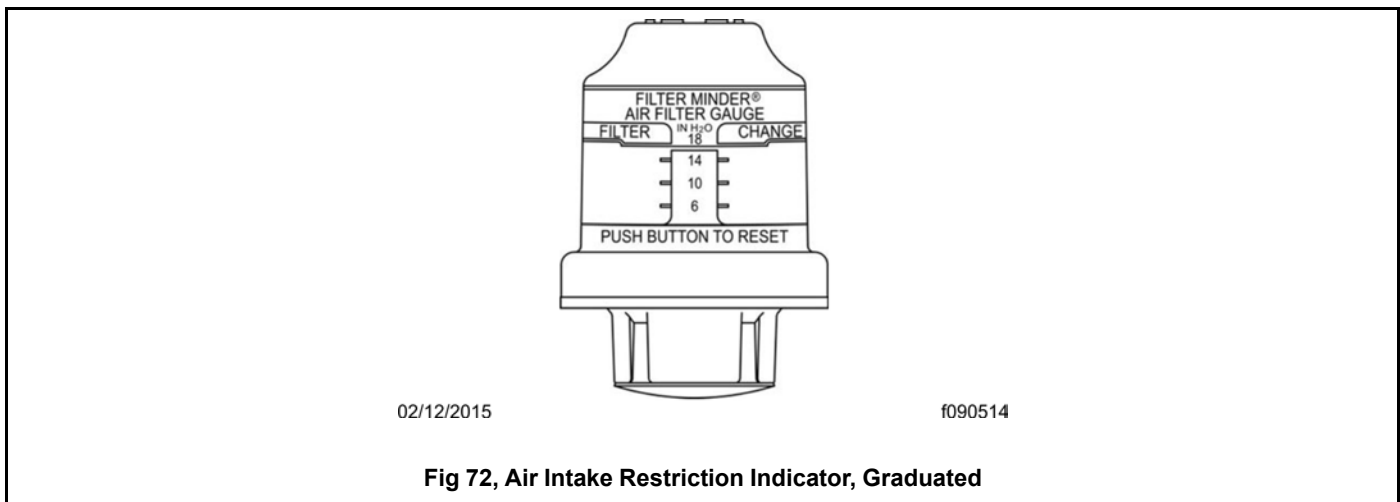

Fig 72, Air Intake Restriction Indicator, Graduated

Air intake restriction vacuum is measured in Inches of Water (in H₂O). For vehicles equipped with a graduated indicator or a restriction gauge on the dash, check the gauge with the engine off. If the yellow signal stays locked in the red zone once the engine is shut down, or is at or above the values, shown in Table 3, [Air Intake Maximum Restriction Values \(in H₂O\)](#), the air cleaner element needs to be replaced.

Engine Make	GHG14, GHG17, and GHG21 Engines
Cummins	25
Detroit	18

Table 1, Air Intake Maximum Restriction Values (in H₂O)

NOTE: Rain or snow can wet the filter and cause a temporary high reading.

4.05.02 Application Air Pressure Gauge

Physical instruments are listed here in alphabetical order. Some are optional and therefore not found in every vehicle. Digital instruments and gauges are described in their ICU section.

An application air pressure gauge (see Fig.73,[Application Air Pressure Gauge](#)) registers the air pressure being used to apply the brakes, and should be used for reference only. The gauge will not register air pressure until the foot brake pedal is depressed or the trailer hand brake is applied.



Fig 73, Application Air Pressure Gauge

4.05.03 Coolant Temperature Gauge

Physical instruments are listed here in alphabetical order. Some are optional and therefore not found in every vehicle. Digital instruments and gauges are described in their ICU section.



NOTICE:

A sudden increase in coolant temperature may indicate engine or cooling system failure. Bring the vehicle to a safe stop and investigate the cause to prevent further damage. Do not operate the engine until the cause has been determined and corrected.

During normal engine operation, the coolant temperature gauge should read 175 to 195°F (79 to 91°C). If the temperature remains below 160°F (71°C), inspect the cooling system to determine the cause. See Fig.

[74, Analog Coolant Temperature Gauge - ICUC.](#)

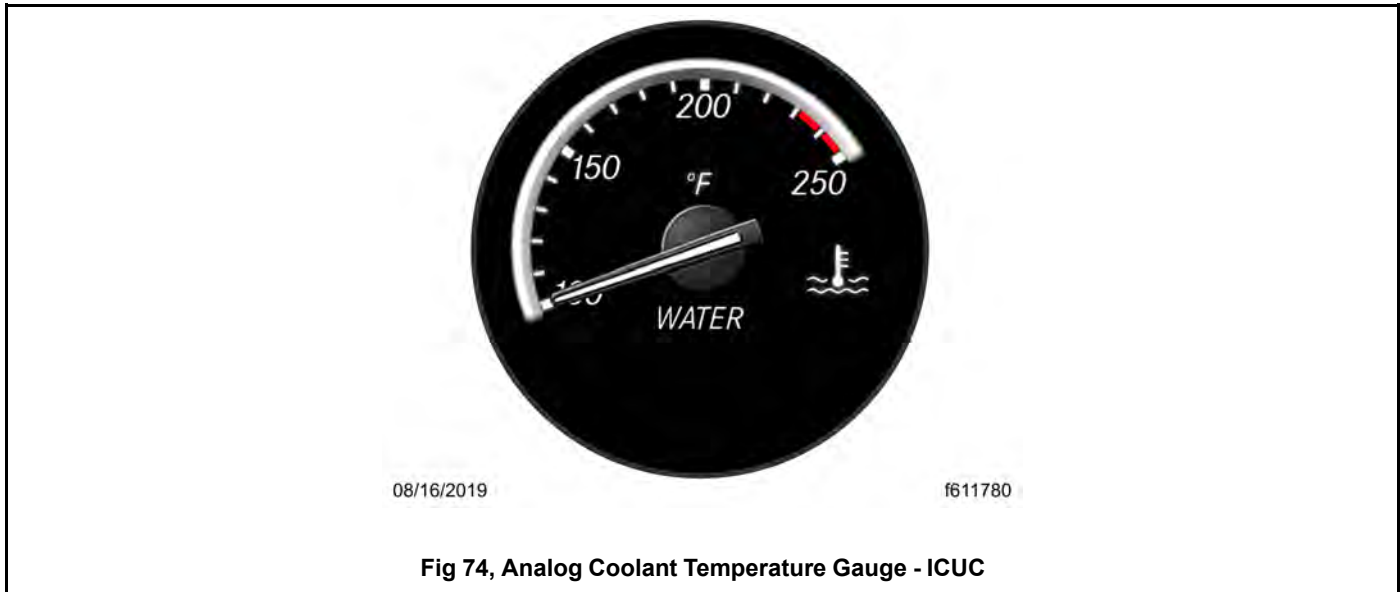

Fig 74, Analog Coolant Temperature Gauge - ICUC

For Detroit engines, if coolant temperature rises above the maximum temperature listed in Table 4, [Maximum Coolant Temperature](#), the CHECK engine lamp will illuminate. If the condition does not improve, the STOP engine lamp will also illuminate and an audible warning will sound. The engine will then derate or shut down, depending on the type of engine protection system installed.

For Cummins engines, the fan will come on when the coolant temperature reaches 215°F (101°C) and the check engine light will illuminate when coolant temperature rises above the maximum temperature listed in Table 4, [Maximum Coolant Temperature](#).

Engine Make	Temperature: °F (°C)
Cummins	221 (105)
Detroit DD13/DD15/DD16	234 (112)

Table 2, Maximum Coolant Temperature

4.05.04 Drive Axle Oil Temperature Gauges

Physical instruments are listed here in alphabetical order. Some are optional and therefore not found in every vehicle. Digital instruments and gauges are described in their ICU section.



NOTICE:

A sudden increase in oil temperature that is not caused by a load increase may indicate mechanical failure. Bring the vehicle to a safe stop and investigate the cause to prevent further damage. Do not operate the vehicle until the cause has been determined and corrected.

During normal operation, the drive axle oil temperature gauges should read as follows:

- 160 to 220°F (71 to 104°C) for Detroit® Classic Model 2, 4, and 6 axles.
- 160 to 329°F (71 to 165°C) for Detroit® New Final Drive (NFD) axles.
- 160 to 329°F (71 to 165°C) for Detroit® Adaptive Tandem 6 X 4 axles.

- 160 to 275°F (71 to 135°C) for Meritor drive axles.
- 180 to 200°F (82 to 93°C) for Dana Spicer® drive axles.

Under heavy loads, such as when climbing steep grades, temperatures that exceed the normal oil temperature range for a short period are not unusual. If the temperature returns to normal when the load decreases, there is no problem. See Fig.75, Drive Axle Oil Temperature Gauge (rear drive axle gauge shown).

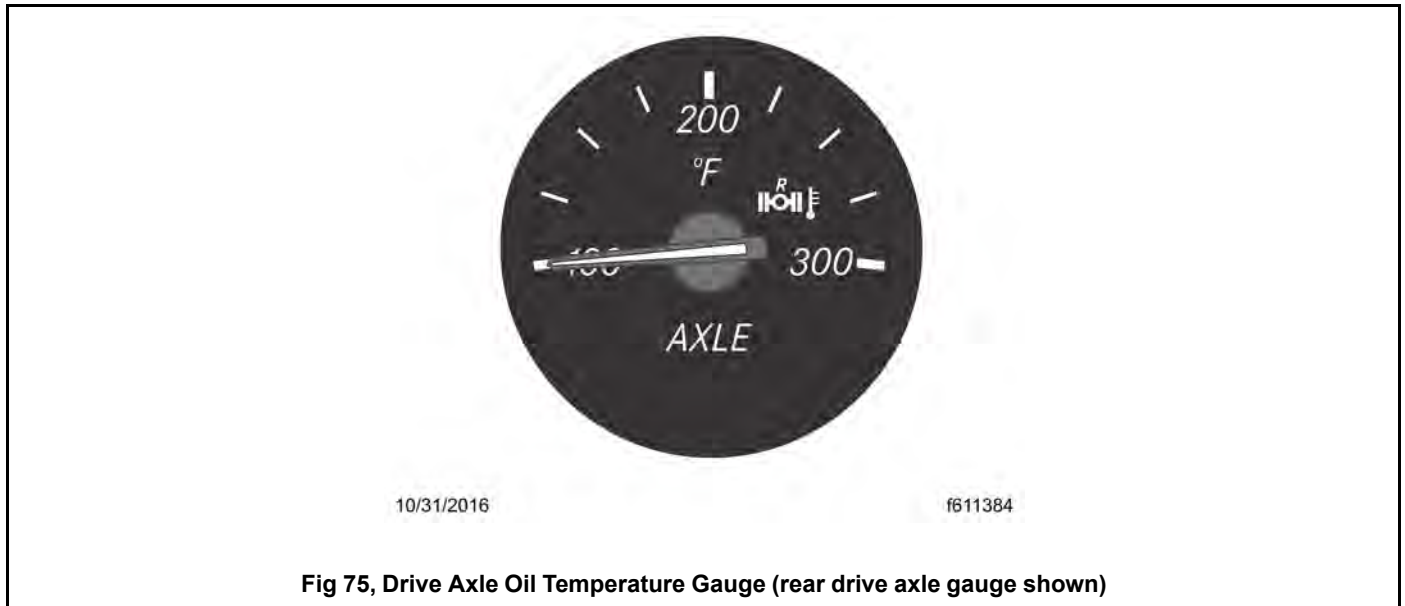

4.05.05 Engine Oil Pressure Gauge

Physical instruments are listed here in alphabetical order. Some are optional and therefore not found in every vehicle. Digital instruments and gauges are described in their ICU section.



NOTICE:

A sudden decrease or absence of oil pressure may indicate mechanical failure. Bring the vehicle to a safe stop and investigate the cause to prevent further damage. Do not operate the engine until the cause has been determined and corrected.



Fig 76, Analog Engine Oil Pressure Gauge - ICUC

Except for Detroit Gen 5 DD13 and DD15 engines, the engine oil pressure gauge displays the current engine oil pressure. If engine oil pressure falls below the minimum levels shown in Table 5, [Minimum Engine Oil Pressure](#), the CHECK engine lamp will illuminate. If the condition does not improve, the STOP engine lamp will also illuminate and an audible warning will sound. The engine will then derate or shut down, depending on the type of engine protection system installed.

NOTE: Oil pressures are given with the engine at operating temperature. With the engine cold, oil pressure may be higher. Individual engines may vary from the listed pressures; observe and record pressures when the engine is new to create a guide for checking engine condition.

Engine Model	At Idle Speed: ¹ psi (kPa)	At Rated RPM: ² psi (kPa)
Cummins	15 (103)	35 (241)
Detroit Gen 5 DD13/DD15	50 (344)	50 (344)
All Other Detroit Engines	14 (97)	55 (350)

1. Standard idle speed is 600 RPM. Actual engine idle speed can vary ± 100 RPM depending on transmission type.
2. All Detroit heavy-duty engines are rated at 1800 RPM.

Table 3, Minimum Engine Oil Pressure

For Detroit Gen 5 DD13 and DD15 engines, the gauge will read a steady 50 psi (344 kPa) with normal engine oil pressure. If the engine oil pressure is low, the CHECK lamp will illuminate and the oil pressure gauge will read 25 psi (172 kPa). If the condition does not improve, the STOP lamp will illuminate, an audible warning will sound, and the gauge will read 0 psi. The engine will then derate or shut down, depending on the type of engine protection system installed.

4.05.06 Engine Oil Temperature Gauge

Physical instruments are listed here in alphabetical order. Some are optional and therefore not found in every vehicle. Digital instruments and gauges are described in their ICU section.

**NOTICE:**

A sudden increase in oil temperature that is not caused by a load increase may indicate mechanical failure. Bring the vehicle to a safe stop and investigate the cause to prevent further damage. Do not operate the engine until the cause has been determined and corrected.

During normal operation, the optional engine oil temperature gauge should read in the following temperature range:

- 200 to 260°F (93 to 126°C) for Detroit and Cummins engines

Under heavy loads, such as when climbing steep grades, temperatures that exceed the normal oil temperature range for a short period are not unusual. If the temperature returns to normal when the load decreases, there is no problem. See Fig.77, [Engine Oil Temperature Gauge](#).

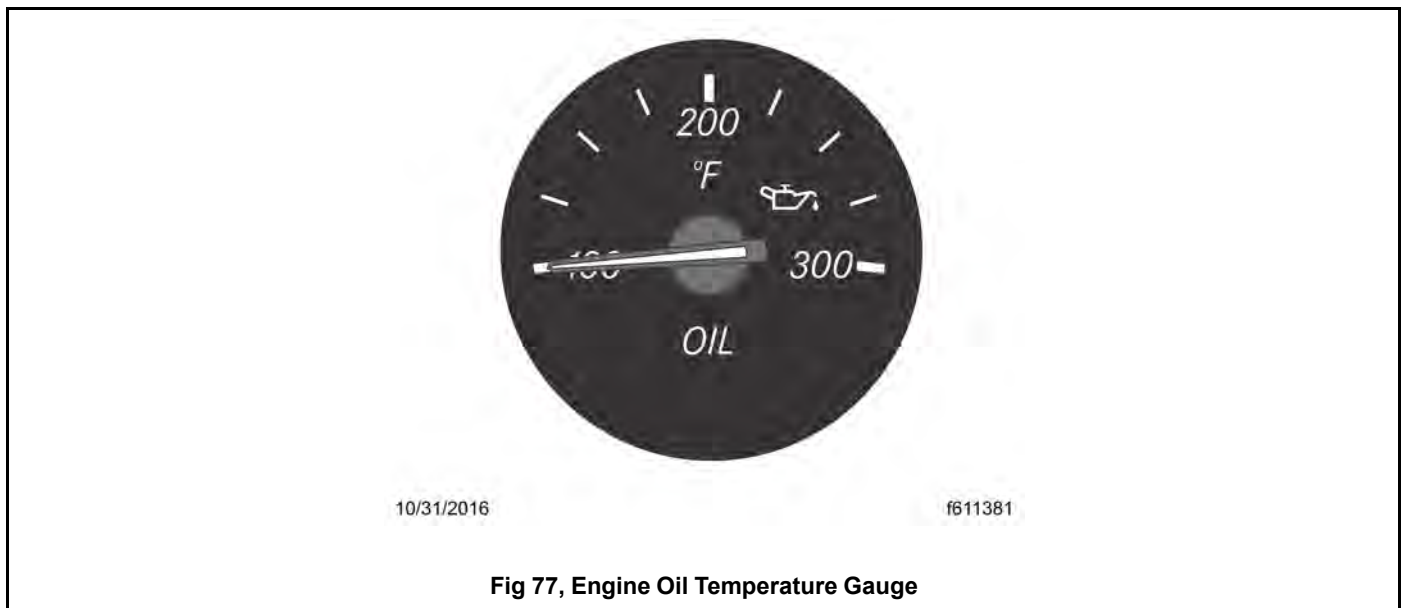

4.05.07 Fuel/Diesel Exhaust Fluid (DEF) Gauge

Physical instruments are listed here in alphabetical order. Some are optional and therefore not found in every vehicle. Digital instruments and gauges are described in their ICU section.



1. Fuel Gauge Pointer
2. DEF Gauge Pointer

3. Low Fuel Warning Lamp
4. Low DEF Warning Lamp

Fig 78, Fuel/DEF Gauge

The fuel and DEF levels can be measured in a dual purpose fuel/DEF level gauge. See Fig. 78, [Fuel/DEF Gauge](#).

The diesel fuel and DEF levels are indicated on the gauge. A low fuel warning lamp illuminates amber when the diesel fuel level registers 1/8th of capacity. The low DEF warning lamp illuminates amber when the DEF level reaches 10% of capacity. See in **Emissions and Fuel Efficiency** for details of the DEF gauge functions.

4.05.08 Primary and Secondary Air Pressure Gauges

Physical instruments are listed here in alphabetical order. Some are optional and therefore not found in every vehicle. Digital instruments and gauges are described in their ICU section.



WARNING:

If air pressure falls below minimum pressure, the braking ability of the vehicle will be limited. Slow the vehicle down and bring it to a gradual stop. Do not attempt to move the vehicle until air pressure has risen above the minimum level. Moving a vehicle without adequate braking power could cause an accident resulting in property damage, personal injury, or death.

Air pressure gauges register the pressure in the primary and secondary air systems. See Fig. 79, [Analog Combined Application Air Pressure Gauge - ICUC](#). Normal pressure, with the engine running, is 100 to 120 psi (689 to 827 kPa) in both systems.

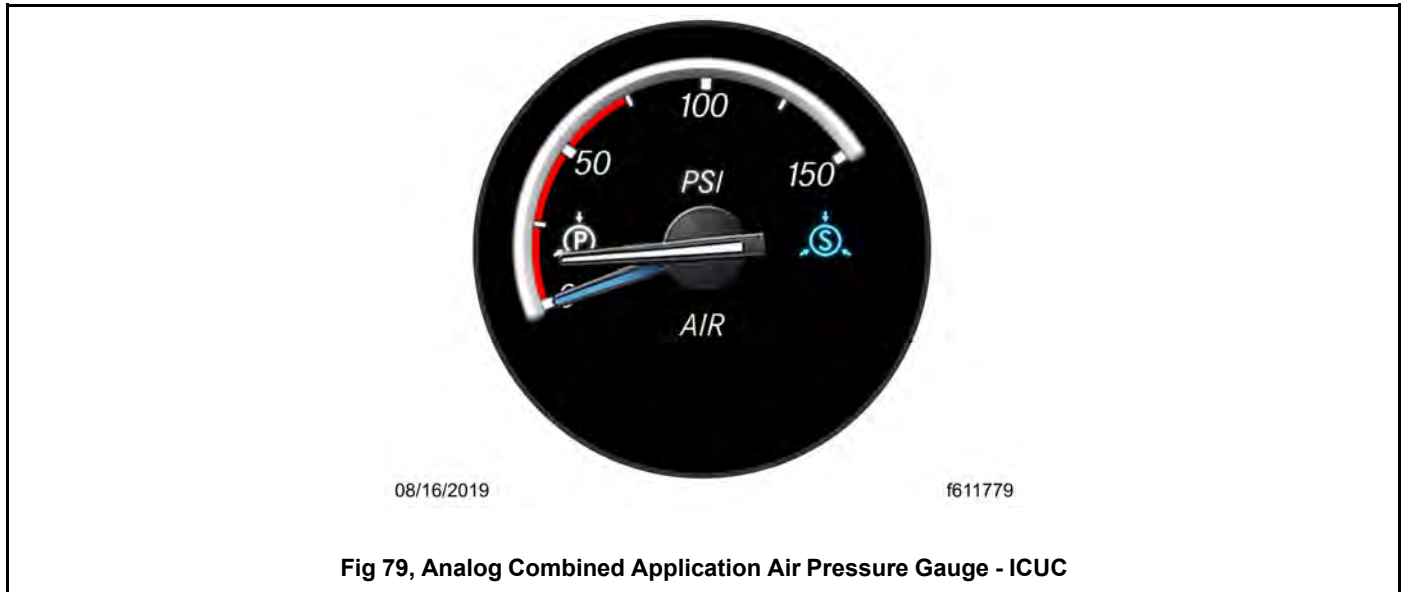

NOTE: The low-air warning buzzer only works when the park brake is released. The low-air warning buzzer is silenced when the park brake is set.

If air pressure drops below approximately 70 psi (483 kPa), a warning light illuminates and the driver display shows a warning. A low-air warning buzzer also sounds if the park brake is not set.

NOTE: If the pressure in both air systems drops below 70 psi, the parking brakes will drag or apply.

4.05.09 Speedometer

Physical instruments are listed here in alphabetical order. Some are optional and therefore not found in every vehicle. Digital instruments and gauges are described in their ICU section.

Two physical speedometer options are available. The U.S. version of the speedometer (see Fig. 80, [Analog Speedometer - ICUC](#)) registers speed in both miles per hour (mph) and kilometers per hour (km/h), with mph in larger numbers. The metric version of the speedometer face reverses this arrangement, with km/h in larger numbers.



4.05.10 Suspension Air Pressure Gauge

Physical instruments are listed here in alphabetical order. Some are optional and therefore not found in every vehicle. Digital instruments and gauges are described in their ICU section.

A suspension air pressure gauge (see Fig.81,[Suspension Air Pressure Gauge](#)) registers the air pressure applied to the vehicle air suspension.

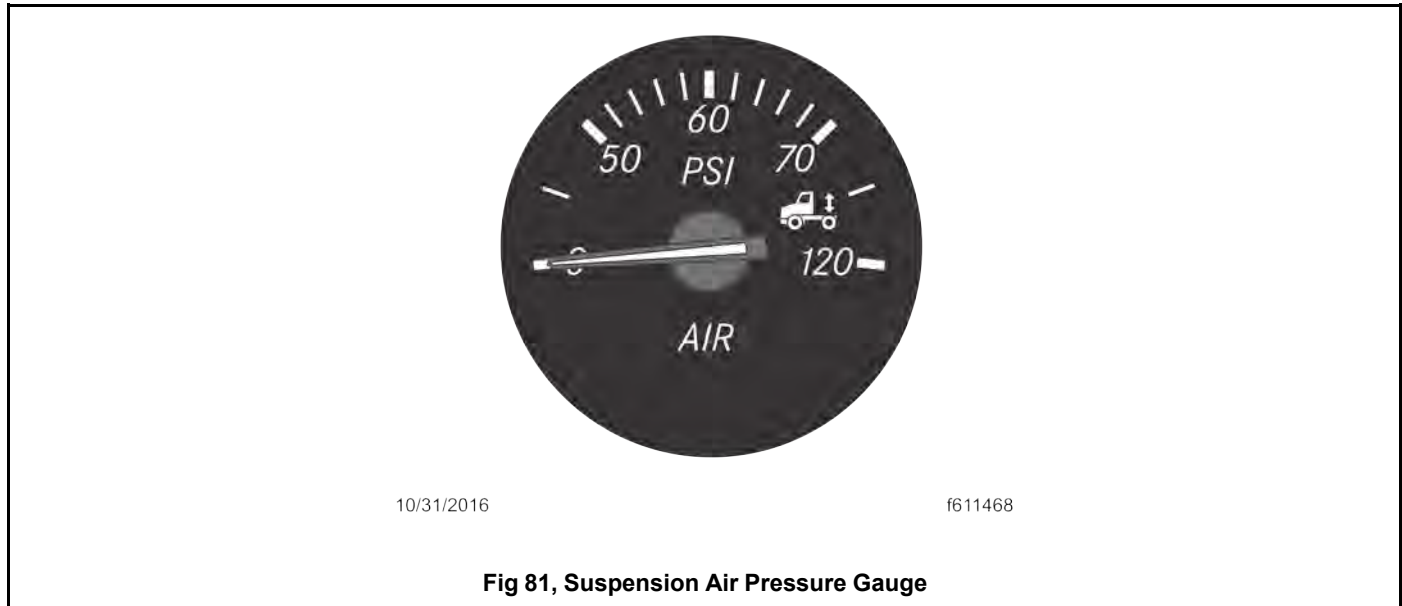

4.05.11 Tachometer

Physical instruments are listed here in alphabetical order. Some are optional and therefore not found in every vehicle. Digital instruments and gauges are described in their ICU section.

The tachometer or rev counter indicates engine speed in revolutions per minute (rpm) and serves as a guide for shifting the transmission and keeping the engine in the appropriate rpm range. The tachometer has only one unit of measurement, 0-2500 rpm. For low idle and rated rpm, consult your vehicle's engine identification plate. See Fig. 82,[Analog Tachometer - ICUC](#).



01/02/2020

f611783

Fig 82, Analog Tachometer - ICUC

4.05.12 Transmission Fluid Temperature Gauge

Physical instruments are listed here in alphabetical order. Some are optional and therefore not found in every vehicle. Digital instruments and gauges are described in their ICU section.

The transmission fluid temperature gauge, (see Fig.83,[Transmission Fluid Temperature Gauge](#)) measures the transmission lubricant operating temperature. Temperatures vary by application, but the transmission fluid temperature gauge reading should not exceed 250°F (121°C).



10/31/2016

f611383

Fig 83, Transmission Fluid Temperature Gauge

**NOTICE:**

A sudden increase in transmission fluid temperature that is not caused by a load increase may indicate mechanical failure. Bring the vehicle to a safe stop and investigate the cause to prevent further damage. Do not operate the vehicle until the cause has been determined and corrected.

Under heavy loads, such as when climbing steep grades, temperatures that exceed the normal oil temperature range for a short period are not unusual. If the temperature returns to normal when the load decreases, there is no problem.

4.05.13 Turbocharger Boost Pressure Gauge

Physical instruments are listed here in alphabetical order. Some are optional and therefore not found in every vehicle. Digital instruments and gauges are described in their ICU section.

A turbocharger boost pressure gauge (see Fig.84, [Turbocharger Boost Pressure Gauge](#)) indicates the pressure in the intake manifold, in excess of atmospheric pressure, being created by the turbocharger.

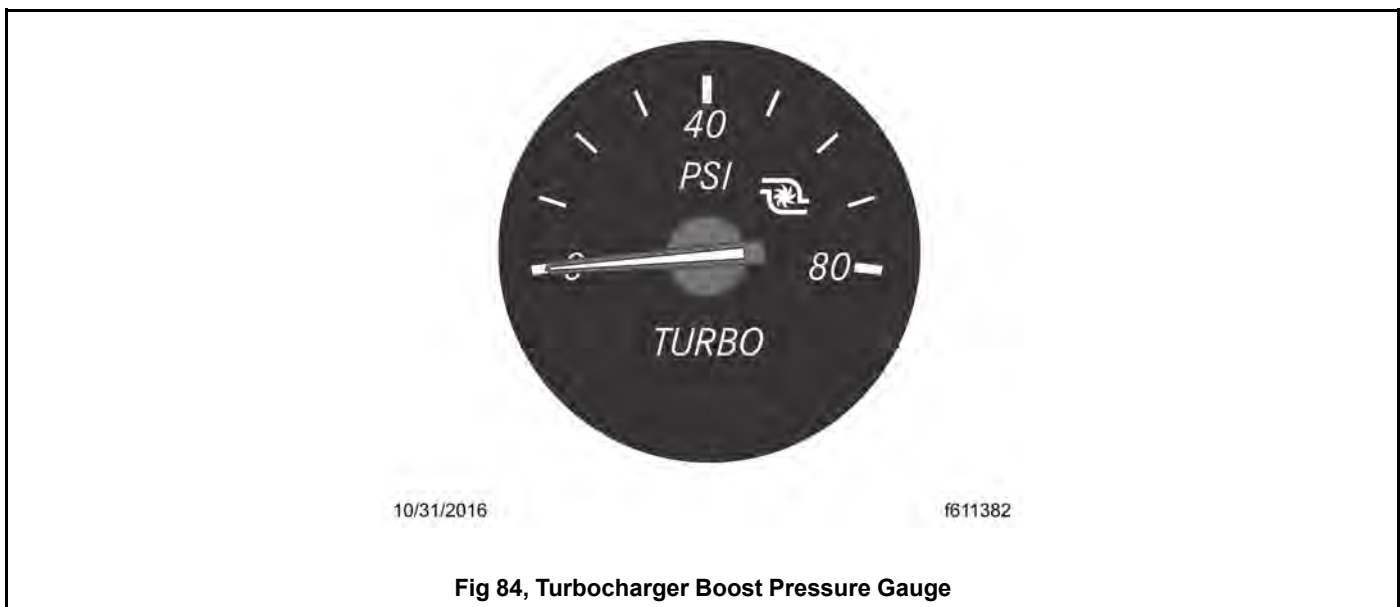

Fig 84, Turbocharger Boost Pressure Gauge

4.05.14 Voltmeter

Physical instruments are listed here in alphabetical order. Some are optional and therefore not found in every vehicle. Digital instruments and gauges are described in their ICU section.

The voltmeter indicates the vehicle charging system voltage when the engine is running and the battery voltage when the engine is off. By monitoring the voltmeter, the driver can stay aware of potential battery charging problems and have them fixed before the batteries discharge enough to create starting difficulties.

The voltmeter will normally show approximately 13.7 to 14.1 volts when the engine is running. The voltage of a fully charged battery is 12.7 to 12.8 volts when the engine is off. Battery voltage under 12.0 volts is considered a low battery, and a completely discharged battery will produce only about 11.0 volts.

If the voltmeter shows an undercharged or overcharged condition for an extended period, have the charging system and batteries checked at an authorized Freightliner service facility.

On a vehicle equipped with a battery isolator system, the voltmeter measures the average voltage of all the batteries when the engine is running. When the engine is off, the voltmeter shows only the isolated battery voltage and does not indicate the voltage of the engine-starting batteries.

4.06 Overhead Instrument Panel

The overhead instrument panel, shown in Fig.85, [Overhead Instrument Panel](#), may hold a citizen's band (C/B) radio, a microphone clip, and any switches that can not be accommodated on the driver's or auxiliary dash panels.



Fig 85, Overhead Instrument Panel

The underside of the overhead console also holds the sun visors and the optional dome/reading light assembly. For more information on the dome/reading light assembly, see [5.01 Ignition Switch and Key](#).

4.07 Warnings, Indicators, and Messages

4.07.01 Audible Alerts: ICUC

An audible alert sounds whenever one of the following conditions exists:

- Engine oil pressure falls below the minimum preset value.
- Coolant temperature rises above the maximum preset value.
- Air pressure falls below approximately 70 psi (483 kPa).
- Parking brake is set with the vehicle moving faster than 2 mph (3 km/h).
- System voltage falls below 11.9 volts.
- Door is unlatched with the parking brake off.

Optional audible alert sounds whenever one of the following conditions exists:

- Driver seat occupancy sensor reads someone in the seat with the seat belt not fastened and the parking brake off.
- Key is in the ignition and the door is unlatched.

4.07.02 Warnings, Indicators, and Messages

Warning and indicator lights (telltales) with icon symbols are displayed on the physical dashboard and on ICU screens. The positions of the telltales and warnings vary, but most telltale symbols are standard. See the below tables for a listing of different warnings and telltales in addition to messages and popup screens.

The colors of telltales and warnings indicate the hazard level: red (warning), amber (caution), green and blue (active status), grey (passive status), white (informational). Blue is currently used to indicate an active phone call, that a software download is available, and that utility lamps and high beams are on.

IMPORTANT: Depending upon local jurisdictional emissions guidelines, vehicles and/or engines that are domiciled outside of the U.S. and Canada may not be compliant with EPA10 or GHG21 regulations. Noncompliant vehicles may not be equipped with all of the telltales shown in the below tables.







Warnings, Indicators, and Messages — Engine System				
Telltale	Color	Description		Related Messages
	Red	Stop Engine ¹	Indicates a serious fault that requires engine shutdown immediately. The engine protection system will reduce the maximum engine torque and speed, and, if the condition does not improve, will shut down the engine within 30 to 60 seconds. Safely bring the vehicle to a stop on the side of the road and shut down the engine as soon as the red light is seen. If the engine shuts down while the vehicle is in a hazardous location, turn the key to the OFF position for a few seconds, then restart the engine and move the vehicle to a safer location.	Various
	Red	Engine Oil Level Warning		
	Red	Low Engine Oil Pressure	Indicates the engine oil pressure is below the minimum allowable pressure.	 04/22/2016 f611368 ICUC Warning
	Red	Engine Oil Temperature Warning		
	Red	Low Coolant Level		

Table 6, Engine-Related Indicators















Warnings, Indicators, and Messages — Engine System				
	Red	High Coolant Temperature	Indicates the coolant temperature is above the maximum allowable temperature.	 ICUC Warning
	Amber	Check Engine ¹	Indicates an engine condition (low oil pressure, low coolant level, high coolant temperature, high DPF soot level, uncontrolled DPF regeneration, or battery voltage 11.9 volts or less) that requires correction. Correct the condition as soon as possible. If the condition worsens, the STOP engine lamp will illuminate.	Various
	Amber	Engine Malfunction Indicator Lamp (MIL) ¹	A steadily illuminated amber MIL lamp indicates an engine fault that effects emissions.	
	Amber	Engine Malfunction Indicator Lamp (MIL) ¹	Alternate Engine Malfunction Indicator lamp. A steadily illuminated amber MIL lamp indicates an engine fault that effects emissions.	
	Amber	Engine Oil Level Caution		
	Amber	Engine Oil Pressure Caution		
	Amber	Low Coolant Level Caution		
	Amber	High Coolant Temperature Caution		

Table 6, Engine-Related Indicators

Warnings, Indicators, and Messages — Engine System				
	Amber	Start Blocked	<p>Indicates that the system is preventing the starter from cranking. This can occur when the ignition switch is turned to START before the gauge sweep has completed.</p> <p>Display of the Start Blocked screen does not indicate a problem with the starter.</p> <p>Turn the ignition switch back to ON, wait for the message to turn off, then turn the ignition switch to START again.</p>	 <p>ICUC Notice</p>
	Amber	Start Blocked	Alternative Telltale for Start Blocked.	
	Green	Start Engine		
	Green	Optimized Idle Active	Indicates optimized idle is active.	

1. See Chapter: **Emissions and Fuel Efficiency** for an explanation of the after treatment system (ATS) warning indicators, and actions required to avoid further engine protection steps.

Table 4, Engine-Related Indicators



Warnings, Indicators, and Messages — Transmission				
Telltale	Color	Description		Related Messages
	Red	Transmission Fluid Level Warning	<p>Indicates low transmission fluid level.</p> <p>Safely bring the vehicle to a stop as soon as possible.</p>	
	Amber	Caution Check Transmission	Indicates an undesirable transmission condition.	

Table 7, Transmission-Related Indicators



Warnings, Indicators, and Messages — Transmission				
	Amber	Low Transmission Fluid Level Caution	Indicates low transmission fluid level.	
	Amber	High Transmission Temperature	Indicates transmission is overheating.	 ICUC Caution

Table 5, Transmission-Related Indicators







Warnings, Indicators, and Messages — Brakes				
Telltale	Color	Description		Related Messages
	Red	Low Brake Air Pressure (EPA10 and Newer)	Indicates air pressure in the primary or secondary reservoir has dropped below approximately 70 psi (483 kPa).	
	Red	Low Brake Air Pressure (EPA10 and Newer)	Alternate low brake air pressure telltale. Indicates air pressure in the primary or secondary reservoir has dropped below approximately 70 psi (483 kPa).	 ICUC Warning
	Red	Parking Brake Engaged (EPA10 and Newer)	Indicates the parking brake is engaged.	
	Red	Parking Brake Engaged (EPA10 and Newer)	Alternative icon indicating the parking brake is engaged.	
	Amber	Hill Start Aid Disengaged	A blinking telltale indicates hill start aid is inactive. A solid telltale indicates a fault with the system.	To turn on HSA, press the HSA OFF switch again or restart the vehicle.

Table 8, Brake-Related Indicators





Warnings, Indicators, and Messages — Brakes				
	Amber	Winch Brake Caution		
	Amber	Work Brake Caution		
	Green	Descent Control Mode Engaged		
	Green	Engine Brake Engaged	Indicates the engine brake is enabled.	

Table 6, Brake-Related Indicators





Warnings, Indicators, and Messages — Driving Safety				
Telltale	Color	Description		Related Messages
	Amber	Electronic Stability Control (ESC) Active	Flashing indicates a stability event has been detected, and the ESC system is active. Solid illumination indicates a problem with the stability system. Repair the ESC system immediately to ensure full stability capability.	
	Amber	Electronic Stability Program Off		
	Amber	Tractor Anti-Lock Braking System (ABS)	Momentary illumination indicates the vehicle ABS is engaged. Solid illumination indicates a problem with the vehicle ABS. Repair the ABS immediately to ensure full braking capability.	
	Amber	Trailer Anti-Lock Braking System (ABS)	Momentary illumination indicates the trailer ABS is engaged. Solid illumination indicates a problem with the trailer ABS. Repair the ABS immediately to ensure full braking capability.	
	Amber	Active Brake Assist Active	Indicates Active Brake Assist is engaged.	

Table 9, Driving-Safety-Related Indicators







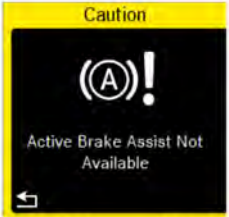

Warnings, Indicators, and Messages — Driving Safety				
	Amber	Active Brake Assist Unavailable (GHG14 and newer)	Indicates the Active Brake Assist system is not available.	 <p>04/22/2016 f611353 ICUC Caution</p>
 ICC5 Telltale	Amber	Lane Departure Unavailable	Indicates that lane departure warning is disabled due to minimum speed, lack of lane markings, or system not being available. Only on vehicles equipped with Detroit Assurance radar.	
 ICUC Telltale	Amber	Lane Departure Unavailable	Indicates that lane departure warning is disabled due to minimum speed, lack of lane markings, or system not being available. Only on vehicles equipped with Detroit Assurance radar.	 <p>06/28/2016 f611372 ICUC Caution</p>
 ICC5 Telltale	Amber	Adaptive Cruise Control Not Available	Indicates that Adaptive Cruise Control (ACC) is not available Only on vehicles equipped with a radar-based collision warning and mitigation system (CWS/CMS).	
 ICUC Telltale	Amber	Adaptive Cruise Control Not Available	Indicates that Adaptive Cruise Control (ACC) is not available Only on vehicles equipped with a radar-based collision warning and mitigation system (CWS/CMS).	 <p>ICUC Caution If ACC is not available, Active Lane Assist (ALA) will not be available.</p>
	Amber	IPPC Error		

Table 9, Driving-Safety-Related Indicators





Warnings, Indicators, and Messages — Driving Safety				
	Green	Adaptive Cruise Control Active		
	Red	Adaptive Power Steering (APS) Error		An error with APS deactivates Active Lane Assist (ALA).
	Blue	Lane Keep Assist (LKA) Active	LKA is a component of Active Lane Assist (ALA) along with Lane Departure Protection (LDP). If Adaptive Cruise Control (ACC) is not available, ALA will not be available.	This is also the Switch icon
	Grey	Lane Keep Assist (LKA) on Standby		When LKA is OFF there is no steering wheel icon
	Amber	Gear Teach Mode in Progress		
	Green	AERO active	Indicates that aerodynamic height control (AERO) is active.	

Table 7, Driving-Safety-Related Indicators



Warnings, Indicators, and Messages — Suspension				
Telltale	Color	Description		Related Messages
	Amber	Suspension Higher than Normal Ride Height / Axle Lifted	Indicates the current rear suspension height is above the normal ride height.	 <p>11/09/2016 f611471 ICUC Caution</p>
	Amber	Suspension Lower Than Normal Ride Height / Axle Dropped	Indicates the current rear suspension height is below the normal ride height.	 <p>06/29/2016 f611434</p>

Table 10, Suspension-Related Indicators

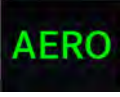



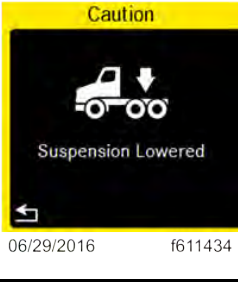

Warnings, Indicators, and Messages — Suspension				
				ICUC Caution
	Amber	Suspension Height		
	Amber	Electronically Controlled Air Suspension (ECAS) Error	Indicates Electronically Controlled Air Suspension (ECAS) active fault.	 <p>04/22/2016 f611367 ICUC Caution</p>
	Amber	Load Transfer	Indicates the ECAS system is applying the maximum available vehicle load on the drive axle up to the maximum gross axle weight rating (GAWR).	 <p>11/09/2016 f611472 ICUC Caution</p>
	Amber	5th Wheel Adjust		

Table 8, Suspension-Related Indicators

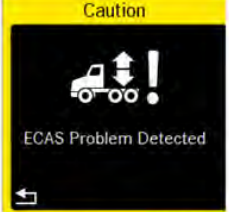

Warnings, Indicators, and Messages — Battery				
Telltale	Color	Description		Related Messages
	Red	Battery Critical		
	Red	Battery Failure		
	Amber	Battery Failure		

Table 9, Battery-Related Indicators





Warnings, Indicators, and Messages — Tires and ATC				
Telltale	Color	Description		Related Messages
	Red	Low Tire Pressure Warning	Indicates a notable loss of tire pressure in at least one tire.	If a tire monitoring system is available, the tire(s) with low pressure will be highlighted red.
	Amber	Low Tire Pressure Warning	Indicates low tire pressure in at least one tire.	If a tire monitoring system is available, the tire(s) with low pressure will be highlighted amber.
	Amber	Automatic Traction Control (ATC) Active	Flashing indicates a wheel spin event has been detected, and the ATC system is active.	
	Amber	Automatic Traction Control (ATC) Deactivated	Indicates the ATC SPIN button has been pressed to allow wheel slip.	

Table 10, Tire-Related Indicators



Warnings, Indicators, and Messages — Fuel				
Telltale	Color	Description		Related Messages
	Amber	Low Fuel	Indicates low fuel level. Refill the main fuel tank.	
	Amber	Water in Fuel Warning	Indicates the fuel may contain water. Drain any water collected in the fuel/water separators.	

Table 11, Fuel-Related Indicators







Warnings, Indicators, and Messages — DEF and DPF				
Telltale	Color	Description		Related Messages
	Red	Diesel Particulate Filter Critical	Indicates a parked regen is required immediately.	 06/10/2016 f611403 ICUC Warning
	Amber	Diesel Particulate Filter (DPF) Status	Solid illumination indicates a regen is required. Change to a more challenging duty cycle (such as highway driving) to raise exhaust temperatures for at least twenty minutes, or perform a parked regen. Blinking indicates that a parked regen is required immediately. An engine derate and shutdown will occur.	 06/10/2016 f611401 ICUC Caution
	Amber	Diesel Particulate Filter Inhibited		
	Green	Diesel Particulate Filter Regeneration in Progress	Indicates a regen is in progress.	
	Amber	High Exhaust System Temperature (HEST)*	Slow (10-second) flashing indicates a regeneration (regen) is in progress. When the HEST lamp is illuminated, do not park the vehicle near objects that can be harmed by high temperatures or flammable materials. Solid illumination indicates high exhaust temperatures at the outlet of the tail pipe when speed is below 5 mph (8 km/h).	

Table 14, Diesel Exhaust Fluid (DEF)- and Diesel Particulate Filter (DPF)-Related Indicators



Warnings, Indicators, and Messages — DEF and DPF				
	Amber	Low Diesel Exhaust Fluid	Indicates low diesel exhaust fluid. Fill the DEF tank.	See Chapter 14 for an explanation of the after treatment system (ATS) warnings, and actions required to avoid further engine protection steps.
	Amber	Low Diesel Exhaust Fluid	Alternative icon to indicate Low Diesel Exhaust Fluid. Fill the DEF tank.	See Chapter 14 for an explanation of the after treatment system (ATS) warnings, and actions required to avoid further engine protection steps.

Table 12, Diesel Exhaust Fluid (DEF)- and Diesel Particulate Filter (DPF)-Related Indicators









Warnings, Indicators, and Messages — Lamps				
Telltale	Color	Description		Related Messages
	Green	Right-Turn Indicator On	Flashing indicates the outside right-turn signal lamps are activated.	
	Green	Left-Turn Indicator On	Flashing indicates the outside left-turn signal lamps are activated.	
	Blue	High-Beams On	Indicates the high-beam headlights are on.	
	Green	Low-Beams On	Indicates the low-beam headlights are on.	
	Blue	Automatic High-Beams On	Indicates the high-beam headlights have been set to automatic and are on.	
	Grey	Automatic High-Beams Off	Indicates the high-beam headlights have been set to automatic and are off.	
	Green	Automatic Low-Beams On	Indicates the low-beam headlights have been set to automatic and are on.	
	Grey	Automatic Low-Beams Off	Indicates the low-beam headlights have been set to automatic and are off.	

Table 15, Lamp-Related Indicators





Warnings, Indicators, and Messages — Lamps				
	Green	Daytime Running Lamps On	Indicates the daytime running lamps are on.	
	Blue	Auxiliary Drive Lamps On	Indicates the auxiliary drive lamps are on.	
	Blue	Utility Lamps On	Indicates the utility lamps are on.	
	Green	Taillights / Marker Lamps On	Indicates the taillights, aka marker lamps, are on.	

Table 13, Lamp-Related Indicators



Warnings, Indicators, and Messages — Passenger Safety				
Telltale	Color	Description		Related Messages
	Red	Unfastened Seat Belt	<p>On some vehicles, activates with an audible alert when the system detects that the parking brake is off and the driver seat belt is not fastened.</p> <p>On vehicles with a seat occupancy sensor, the seat being occupied, seat belt not fastened, and parking brake off will cause this warning to activate.</p> <p>On other vehicles, this lamp illuminates for 15 seconds when the ignition is first turned on.</p>	
	Amber	Supplemental Restraint System (SRS) Error	<p>Indicates a malfunction has occurred in the restraint system and restraint system components may be triggered unintentionally or may not deploy as intended during an accident.</p> <p>Have the restraint system checked and repaired immediately.</p>	

Table 14, Passenger-Safety-Related Indicators

Warnings, Indicators, and Messages — Weather				
Telltale	Color	Description		Related Messages
	White	Snowflake	Indicates ambient air temperature has dropped below 34°F (1°C). Pay attention to road conditions and watch for ice.	 ICUC Caution

Table 15, Weather-Related Indicators



Warnings, Indicators, and Messages — ICU Application				
Telltale	Color	Description		Related Messages
	Blue	Active Phone Call	Indicates a phone is connected to the ICU and a call is active.	The phone screen in the infotainment section of the ICU will also show an active call, including the number being called and call length.
	Blue	Software Download Available	Indicates a software download is available. For reasons of security and optimal vehicle functioning, software updates should be quickly installed.	A pop-up message will also appear.

Table 16, ICU-Application-Related Indicators

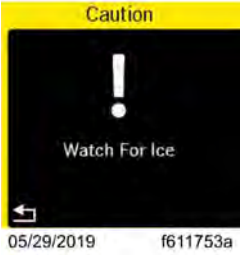

Warnings, Indicators, and Messages — Air Gauge				
Telltale	Color	Description		Related Messages
	Red	Primary Air Warning		
	Red	Secondary Air Warning		

Table 19, Air Gauge-Related Indicators



Warnings, Indicators, and Messages — Air Gauge				
	Red	Application Air Warning		
	Amber	Primary Air Caution		

Table 17, Air Gauge-Related Indicators

4.07.03 Engine Protection System

**WARNING:**

When the red STOP engine lamp illuminates, most engines are programmed to shut down automatically within 30 seconds. The driver must immediately move the vehicle to a safe location at the side of the road to prevent causing a hazardous situation that could cause bodily injury, property damage, or severe damage to the engine.

See [14.01 Greenhouse Gas Emissions and Fuel Consumption Standards](#) Emissions and Fuel Efficiency for an explanation of the aftertreatment system (ATS) warning indicators, and actions required to avoid further engine protection steps.

The STOP engine lamp illuminates when the engine protection system is activated in one of two ways. On some engines, the engine protection system will derate the engine, allowing it to run at lower rpm and slower vehicle speed. Drive the vehicle to a safe location or to a service facility.

IMPORTANT: Safely bring the vehicle to a stop on the side of the road and shut down the engine as soon as the red light is seen. If the engine shuts down while the vehicle is in a hazardous location, turn the key to the OFF position for a few seconds, then restart the engine and move the vehicle to a safer location.

On other engines, the engine protection system will shut down the engine. It will first derate the engine, then shut it down completely 30 to 60 seconds after the indicator illuminates (depending on the critical fault type) if the condition does not improve. Bring the vehicle to a stop on the side of the road before the engine shuts down.

Some vehicles may have a shutdown-override switch, which may be used to momentarily override the shutdown sequence. See [13.01.01 General Information](#) Engine Starting, Operation, and Shutdown for detailed information regarding the shutdown process.

IMPORTANT: Do not attempt to restart the engine while the vehicle is moving. Bring the vehicle to a safe stop, then restart the engine.

To restart the engine, turn the ignition to OFF, leave it there a few seconds, then turn the ignition to START. The engine will run for a short period and shut down again if the condition does not improve.

- 5.01 Ignition Switch and Key..... 102
- 5.02 Adjustable Steering Column..... 103
- 5.03 Windshield Wiper and Washer Controls 104
- 5.04 Exterior Lighting Controls..... 106
 - 5.04.01 Hazard Warning Lamps 109
 - 5.04.02 Marker Lamps 109
- 5.05 Horn Controls 111
- 5.06 Dash-Mounted Brake Controls 111
 - 5.06.01 Parking Brake Control Valve 111
 - 5.06.02 Trailer Air Supply Valve 112
 - 5.06.03 Trailer Brake Lever..... 113
 - 5.06.04 Automatic Traction Control (ATC) Spin Switch..... 113
- 5.07 Powertrain Controls..... 114
 - 5.07.01 Aftertreatment System Regen Switches..... 114
 - 5.07.02 Axle Switches 115
 - 5.07.03 Engine Brake Switches..... 115
 - 5.07.04 Engine Fan Switch 116
 - 5.07.05 Hill Start Aid Override Switch 116
 - 5.07.06 Power Take-Off (PTO) Switch 117
 - 5.07.07 Transmission Controls..... 117
- 5.08 AWD Controls 118
 - 5.08.01 Front Axle Transfer Case Switch 118
 - 5.08.02 Front Axle Transfer Case Range Switch 119
- 5.09 Other Dash-Mounted Controls..... 119

5. Driver Controls

5.01 Ignition Switch and Key

The ignition switch shown in Fig.86, **Ignition Switch**, has four positions: ACCESSORY, OFF, ON, and START

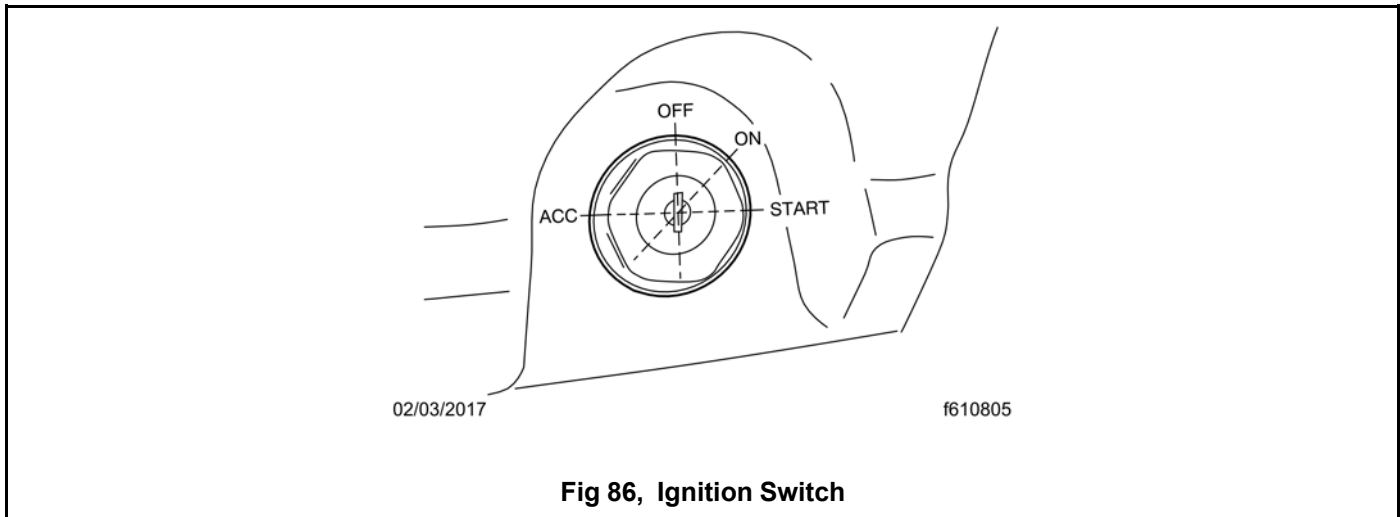

Fig 86, Ignition Switch

In the OFF position, the key slot is vertical; the key can be inserted and removed only in the OFF position. If equipped, the following can be operated in the off position (regardless of whether the key is inserted):

- low-beam headlights
- taillights
- brake lights
- road lights
- dome lights
- hazard warning lights
- turn signals
- power windows
- cigarette lighter
- horn
- clock
- CB radio
- electric oil pan heater

In the ACCESSORY position, the key is turned counterclockwise. The following functions operate when the switch is in the ACC position:

- ICU
- mirror heat
- radio/stereo system
- air dryer
- backup lights

In the ON position, the key is turned clockwise and all electrical systems are operable. The warning and indicator lamps illuminate.

IMPORTANT: Do not crank the engine until the ICU self-check is complete.

The low air pressure and low oil pressure warning telltales (or messages) may appear until the engine starts and the pressure builds up.

Turn the key clockwise past the ON position to reach the START position to start the engine. Release the key the moment the engine starts. Do not operate the starter longer than thirty seconds. Allow the starter to cool between attempts. If the starter overheats, the starter protection system prevents operation of the starter until it has cooled.

5.02 Adjustable Steering Column

To unlock the steering column to adjust it, pull the steering column locking lever out and away from the column. See Fig. 87, [Unlocking the Steering Column](#). With the column unlocked, the steering wheel can be adjusted up-and-down and tilted fore-and-aft. Once the wheel is in the desired position, lock the position by pushing the lever in toward the column until it goes no further and is parallel to the column itself.



WARNING:

Make sure that the steering column is locked before driving the vehicle. Never attempt to adjust the column while driving the vehicle. Doing so could cause loss of vehicle control, personal injury, and property damage.



09/14/2016

f462301

A. A. Pull the steering column locking lever out and away from the column.

Fig 87, Unlocking the Steering Column

5.03 Windshield Wiper and Washer Controls

**NOTICE:**

Do not attempt to manually move the windshield wiper arms. Wiper motor damage will occur if the arms are forcibly moved.

The windshield wipers and washer controls are on the multi-function turn signal lever on the left-hand side of the steering column. See Fig.88, [Windshield Wiper/Washer Controls](#).

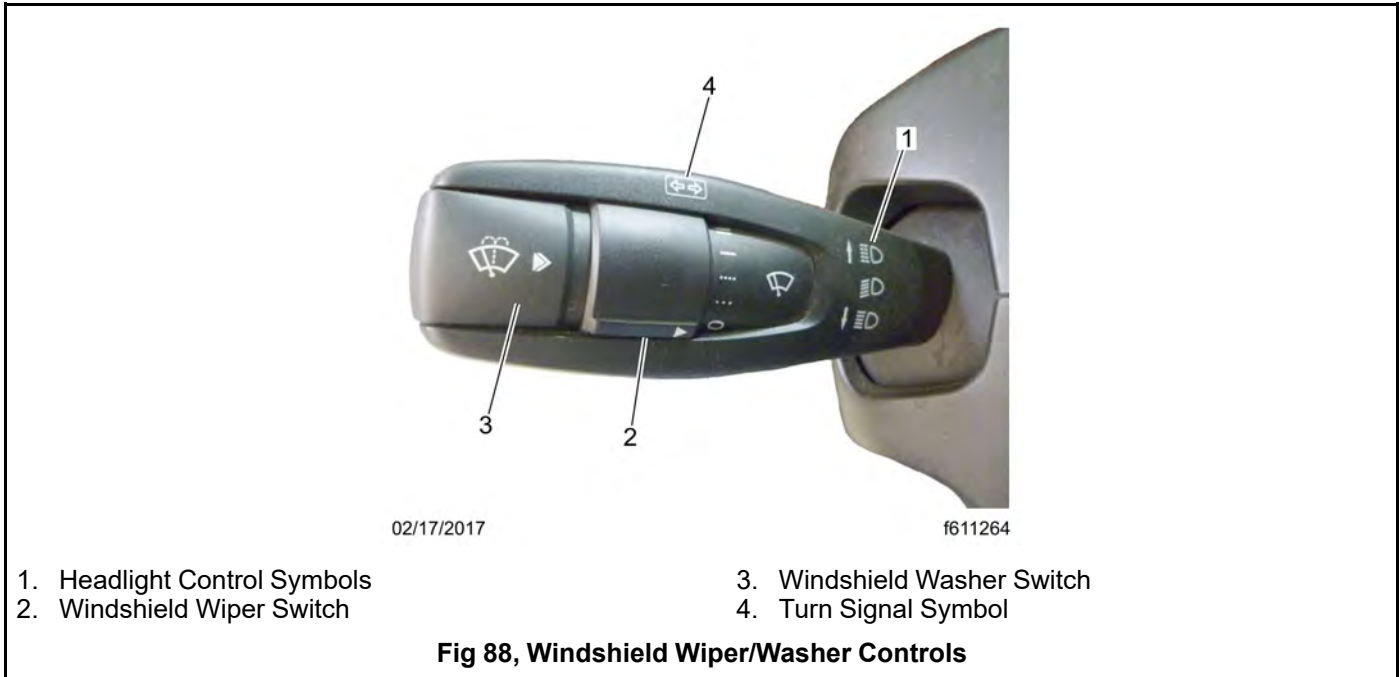

Wiper Controls

The wipers are operated by a rotary switch on the turn signal lever. There are five settings: off, two intermittent settings, and two continuous speeds. Symbols mark each setting on the dial.

Turn the wipers on by rotating the rotary switch up. Rotate the switch further to increase the speed of the wipers through the two intermittent settings, then to continuous low and high speeds. Rotate the switch down to slow the wipers down. Rotate the switch as far down as it will go to turn the wipers off.

The default speeds for the two intermittent settings are 6 seconds and 1 second.

The first intermittent setting of 6 seconds is programmable from 1 to 25 seconds. To program the interval, rotate the switch from the first intermittent position to the OFF position, wait for the desired interval between wipes to lapse (between 1 and 25 seconds), and then move the switch back to the first intermittent position. If the switch is kept in the OFF position for more than 50 seconds, the interval changes back to the default of 6 seconds.

The second intermittent setting has an interval of 1 second, and is not programmable.

NOTE: Some vehicles may have a feature that automatically turns on the headlights if the windshield wipers are on and the vehicle is moving faster than 10 mph (16 km/h). At speeds between 10 and 40 mph (16 to 64 km/h), cycling the headlight switch will turn the headlights off.

Wipers and the Rain/Light Sensor

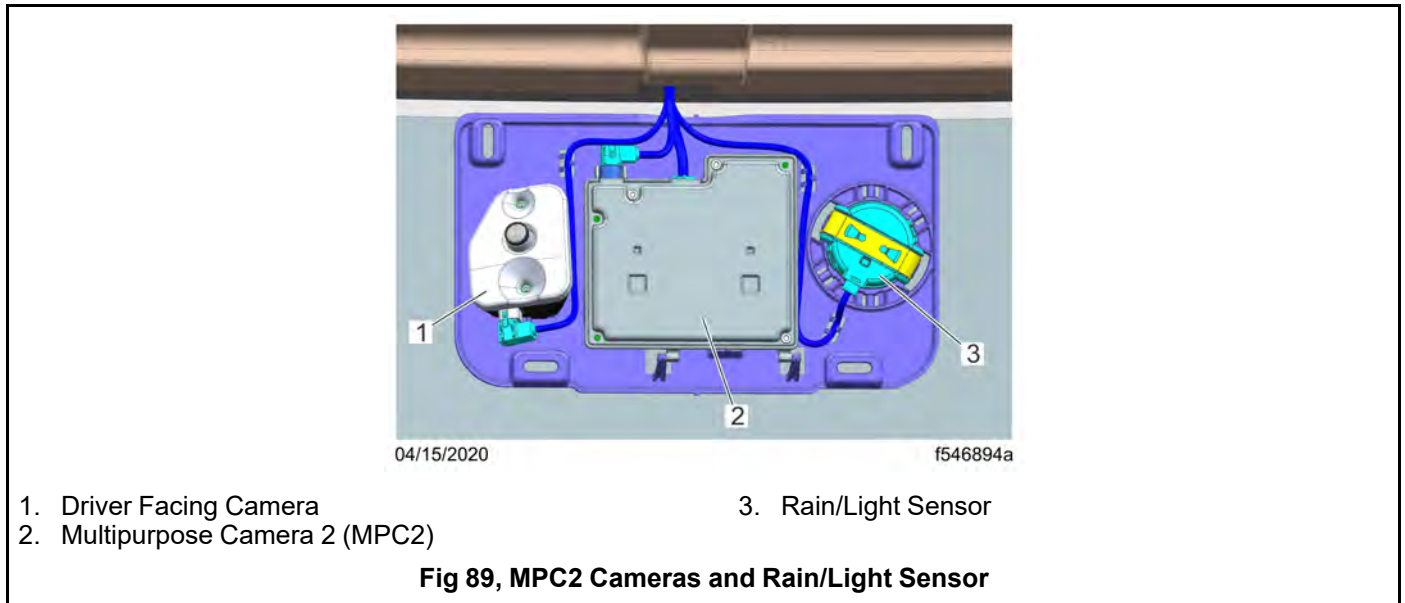

If the vehicle is equipped with a rain/light sensor shown in Fig.89,[MPC2 Cameras and Rain/Light Sensor](#), and the wiper switch is in set to an intermittent setting, the wipers will start when the sensor detects rain or snow.

If the vehicle is moving faster than 40 mph (64 km/h) the wiper speed will automatically increase and decrease, dependent upon how much moisture builds up on the windshield between wipes.

If the wiper switch is set to a continuous speed (low or high), input from the rain/light sensor is ignored.

The behavior of the wipers based on the rain/light sensor input is independent of the headlamp switch position.

NOTE: If a rain/light sensor is installed in the MPC2 bracket, the lens area of the camera will appear shiny when viewed through the windshield because of the silicone gel between the lens and the windshield. If no rain/light sensor is installed, the plastic plug placed in the bracket will appear as a flat black circle.

A vehicle equipped with automatic headlights and an A option on the headlight switch shown in Fig. 90,[Headlamp Switch](#), should be equipped with a rain/light sensor.

Windshield Washers

The windshield washer button is located at the end of the turn signal lever. Momentarily press the windshield washer button to initiate a single wipe without activating the washer pump. The wipers will swipe one full cycle and return to the inactive position.

To operate the windshield washers, press and hold the button in. After a short delay, the washer will pump windshield washer fluid onto the windshield for as long as the washer button is pressed. The windshield wipers turn on at low speed while the washer button is pressed. After the button is released, the wipers continue to operate for one to several wipe cycles, depending on how long the wash button was pressed initially.



08/28/2018

f611525

- | | |
|---|-----------------|
| 1. Fog lamps (optional)—Activate by pulling the switch out when the marker lamps or headlamps are on. | 3. Off |
| 2. Automatic Headlamps | 4. Marker lamps |
| | 5. Headlamps |

Fig 90, Headlamp Switch

5.04 Exterior Lighting Controls

Unless otherwise noted below, press the upper half of the dash switch to turn the desired light(s) on or off.

Turn Signals

The turn-signal lever is mounted on the left-hand side of the steering column. Pulling the turn-signal lever up activates the right-turn signal; pushing it down activates the left-turn signal. The lever is typically a non-canceling combination turn-signal, windshield wiper/washer switch, and high beam headlamp control unit. See Fig. 91, [Windshield Wiper/Washer Controls](#).

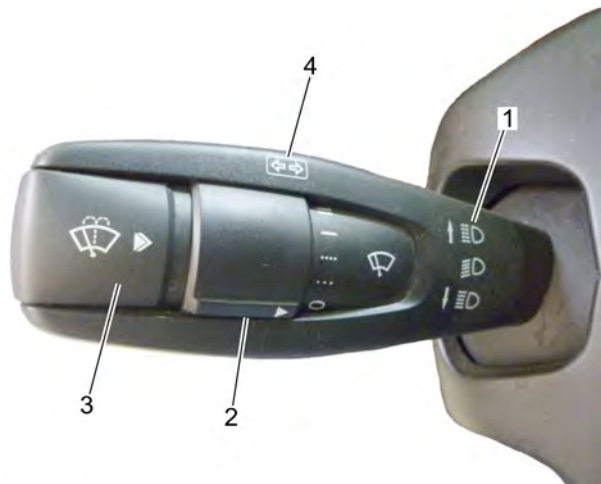

02/17/2017

f611264

- | | |
|------------------------------|-----------------------------|
| 1. Headlight Control Symbols | 3. Windshield Washer Switch |
| 2. Windshield Wiper Switch | 4. Turn Signal Symbol |

Fig 91, Windshield Wiper/Washer Controls

When a turn signal is activated, a green telltale lamp flashes on the instrument panel.

On a self-canceling turn signal lever, the lever automatically returns to the neutral position when the steering wheel returns to the straight-ahead position after a turn.

Headlamp Switch

The headlamp switch is a rotary switch located to the left of the steering column, above the ignition switch. See Fig. 92, [Headlamp Switch](#).

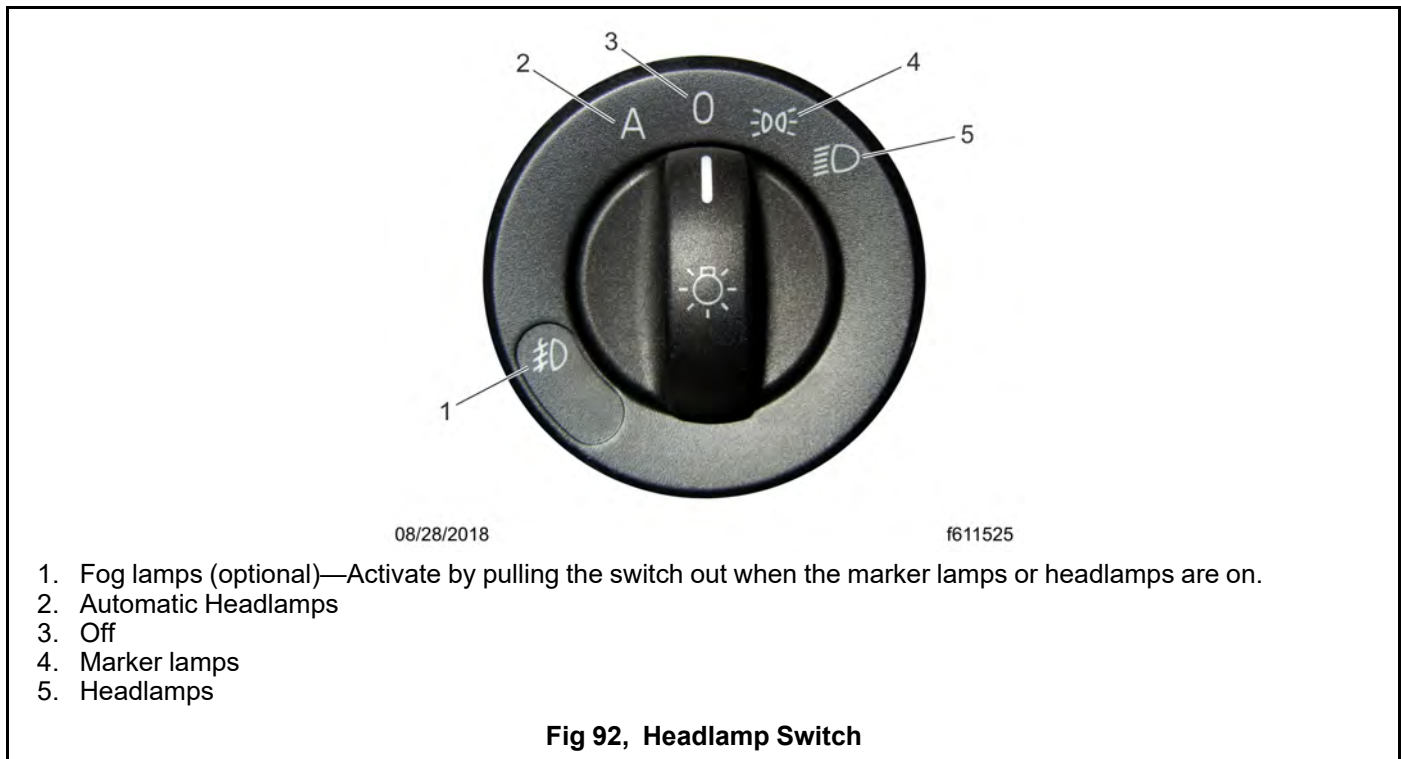

High-Beam Headlamps

With the low-beam headlamps on, push the turn-signal lever away from you to turn on the high-beam headlamps. See Fig.91, [Windshield Wiper/Washer Controls](#). To turn off the high-beam headlamps, pull the lever to the middle position.

With the low-beam headlamps on, pull the lever towards you to flash the high-beam headlamps momentarily.

When the high-beam headlamps are on, a blue telltale illuminates on the instrument cluster.

NOTE: The ignition switch must be on for the high beams to work.

Automatic Headlamps

If the vehicle is equipped with a rain-light sensor and the headlamp switch is in the 'A' position, the low beam headlamps and all exterior lamps activate when the outside light decreases to a pre-set level. See Fig.92, [Headlamp Switch](#).

Some vehicles may have a feature that automatically turns on the headlamps if the windshield wipers are on and the vehicle is moving faster than 10 mph (16 km/h). At speeds from 10 to 40 mph (16 to 64 km/h), cycling the headlamp switch turns the headlamps off.

Intelligent High-Beam Headlamps

The intelligent high-beam headlamp feature activates when the headlamp switch is in the 'A' position and the turn signal lever is pushed away from the driver in the high-beam position. See Fig.91, [Windshield Wiper/Washer Controls](#) and 92, [Headlamp Switch](#).

When a vehicle approaches from the opposite direction, the high-beam headlamps deactivate and the low-beam headlamps activate. The high-beam headlamps activate again when there are no vehicles approaching from the opposite direction.

Auxiliary High Beam Lamps

If present, auxiliary high-beam lamps are located in the front bumper. To activate the auxiliary high beam lamps, press the upper part of the dash switch. The auxiliary high beam lamps illuminate only when the high-beam headlamps are on. They switch off temporarily when the low-beam headlamps are on, until the high beams are on again. Press the upper half of the switch to deactivate the auxiliary high beam lamps. See Fig.93, [Dash-Mounted Light Switches](#).

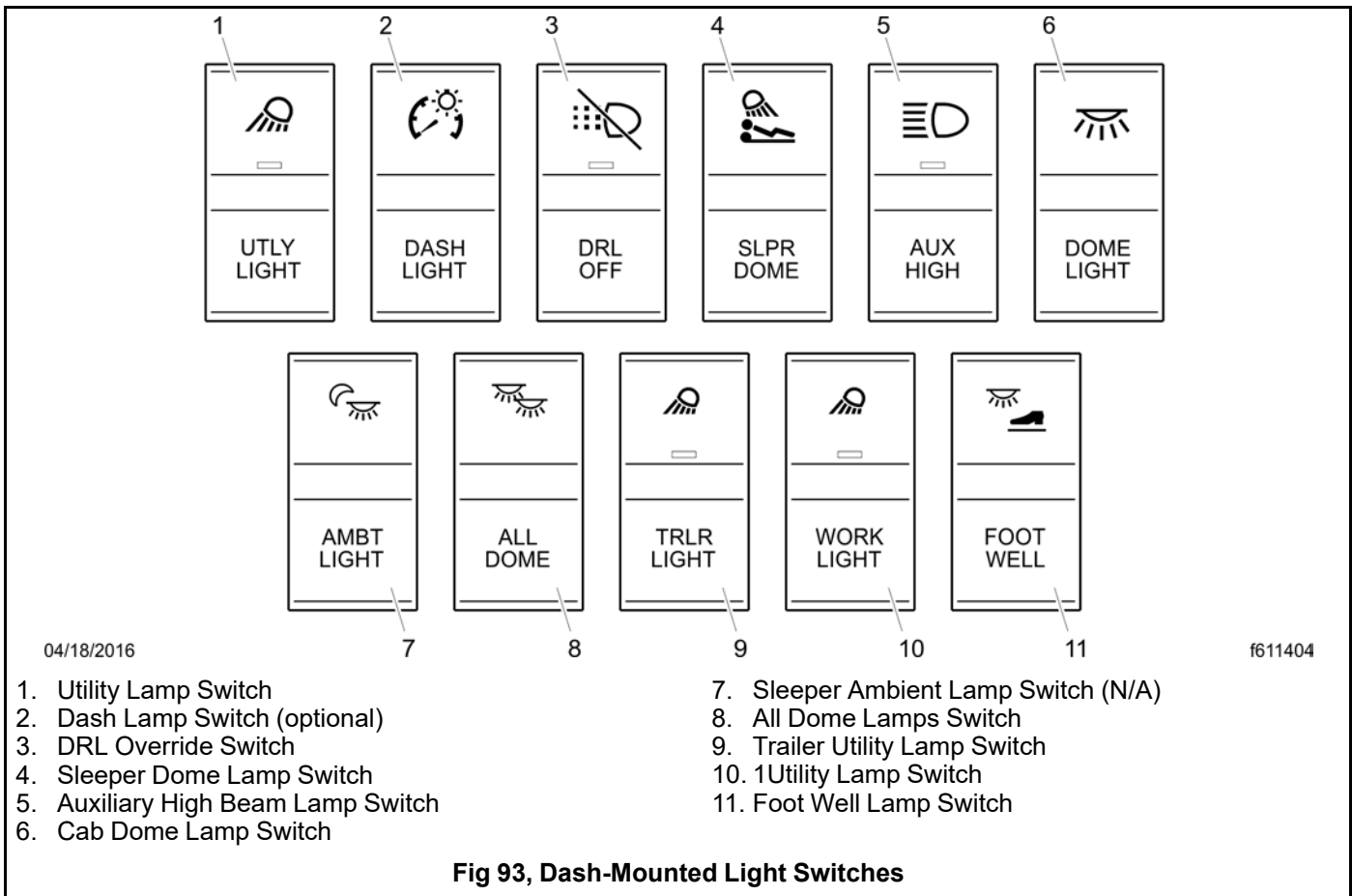

Daytime Running Lamps

If the vehicle is equipped with daytime running lamps (DRL), they are automatically activated when the ignition is switched on and the parking brake is released. The DRL turn off when the engine falls below 400 rpm, the parking brake is applied, or the headlamps are turned on.

Daytime running lamps are mandatory for vehicles domiciled in Canada. Vehicles domiciled in any other location may have an optional override switch. See Fig.93, [Dash-Mounted Light Switches](#), ref. 3. This is a momentary switch that enables the driver to deactivate the DRL.

Fog Lamps

Fog lamps are designed to reduce glare in foggy conditions. The marker lamps or headlamps must be on in order to turn the fog lamps on. Pull the headlamp switch outward to activate the fog lamps.

5.04.01 Hazard Warning Lamps

The hazard warning lamp switch is located on the dash switch panel. See Fig.94, [Right-Hand Panel Dash Controls](#). The hazard lamps can be activated regardless of the ignition switch position.

To activate the hazard lamps, press the center of the switch once. The switch will blink at the same rate that the hazard lamps flash. Press the switch again to turn them off. All the turn signals on the vehicle and trailer, as well as the turn signal indicators in the ICU, flash simultaneously when the hazard lamps are activated.



1. Parking Brake Control
2. Trailer Air Supply Control

3. Hazard Warning Switch
4. Trailer Brake Control

Fig 94, Right-Hand Panel Dash Controls

5.04.02 Marker Lamps

To turn the marker lamps on, turn the headlamp switch clockwise past the off position. See Fig..

Marker Interrupt Switch

The marker interrupt switch is located in the right-hand switch pod of the steering wheel for the ICUC system. See Fig. 95, [Steering Wheel Right-Hand Switch Pod - ICUC](#). Pressing it temporarily flashes the marker lamps.



11/29/2022

f612194

1. Phone Hang-Up/Reject
2. Marker Interrupt
3. Phone Pick-Up
4. Headlamp Interrupt
5. Cruise Accelerate/Resume
6. Quick Access System Settings
7. Cancel Cruise Control
8. Cruise Decelerate/Set

Fig 95, Steering Wheel Right-Hand Switch Pod - ICUC

Pretrip Light Test Switch

When the driver presses the pretrip light test switch, shown in Fig.96, [Pretrip Light Test Switch](#), all exterior lights are activated so the driver can exit the vehicle and verify they are working properly. For additional information see [23.01 Safety Precautions](#) Pre- and Post-Trip Inspections and Maintenance.

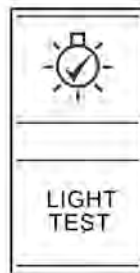

05/09/2022

f611436

Fig 96, Pretrip Light Test Switch

Spotlamp

The spotlamp switch is located on the pivoting handle of the spotlamp. There may be a single spotlamp assembly mounted above the driver's door, or one above each door.

Utility Lamps

Utility lamps can be swivel-mounted on the upper half of the cab, mounted on the exhaust support, or flush-mounted on the back of the cab or sleeper. Press the upper half of the switch to turn the utility lamps on or off.

When activated, a red indicator light in the switch is illuminated.

Backup Lamps

Backup lamps activate only when the vehicle is in reverse, and are designed to be used while backing up at night.

5.05 Horn Controls

Air Horn

Air horn(s) may be mounted on the roof of day cabs, or under the driver-side floor for sleeper cabs. The air horn is controlled by a wire lanyard that hangs down inboard by the driver's door. See Fig.97, [Air Horn Control](#). Pull downward on the lanyard to sound the air horn.

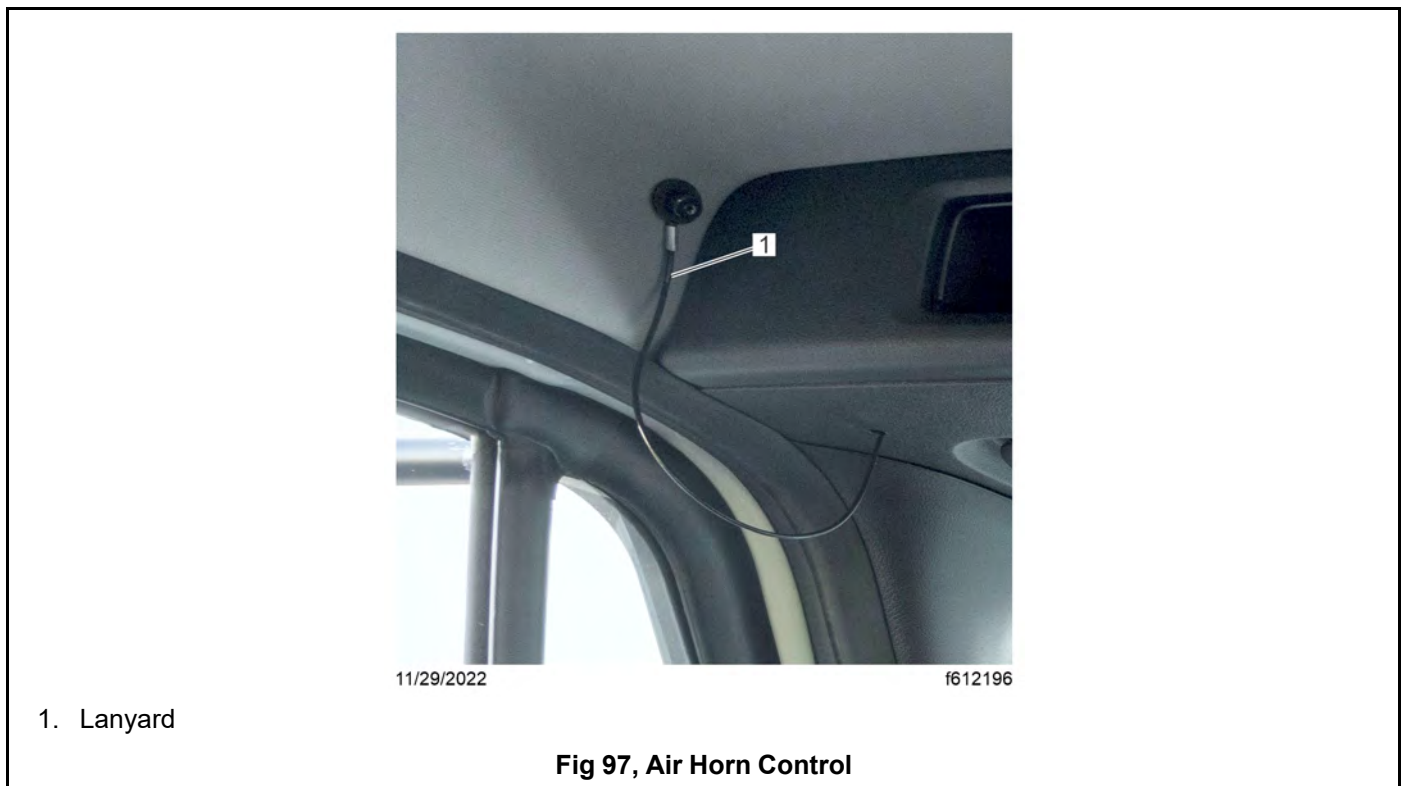

Electric Horn

The electric horn is activated by pressing down on the top of the steering wheel center pad.

The horn will sound for the duration that the button is pressed, up to 60 seconds. The electric horn will operate regardless of the position of the ignition key.

5.06 Dash-Mounted Brake Controls

5.06.01 Parking Brake Control Valve

NOTE: See [12.01.01 Air Brake System, General Information](#) Brake Systems, for additional information about brake systems.

The yellow diamond-shaped knob operates the parking brake valve. See Fig.98, [Right-Hand Panel Dash Controls](#). Pull the knob out to apply both the tractor and the trailer spring parking brakes. Push both the parking brake and the trailer air supply knobs in to release the tractor and trailer spring parking brakes. Before the spring parking brakes can be released, the air pressure in either air brake system must be at least 65 psi (447 kPa).

If the trailer is not equipped with spring parking brakes, pull the parking brake valve out to apply the tractor parking brakes and the trailer service brakes.



- 1. Parking Brake Control
- 2. Trailer Air Supply Control
- 3. Hazard Warning Switch
- 4. Trailer Brake Control

Fig 98, Right-Hand Panel Dash Controls

5.06.02 Trailer Air Supply Valve

The red octagonal-shaped knob operates the trailer air supply valve, which charges the trailer air supply system and releases the trailer spring parking brakes. See Fig.99, [Right-Hand Panel Dash Controls](#).

After the vehicle and its air hoses are connected to a trailer and the pressure in the air system is at least 65 psi (447 kPa), push the trailer air supply valve knob in (and leave it in) to charge the trailer air supply system and release the trailer spring parking brakes. Pull the trailer air supply valve out before disconnecting a trailer or when operating a vehicle without a trailer.



- 1. Parking Brake Control
- 2. Trailer Air Supply Control
- 3. Hazard Warning Switch
- 4. Trailer Brake Control

Fig 99, Right-Hand Panel Dash Controls

5.06.03 Trailer Brake Lever

The trailer brake lever is used to apply the trailer service brakes without applying the truck or tractor service brakes. It is usually mounted on the right-hand control panel. Move the lever down to apply the trailer brakes; move the lever up to release the trailer brakes. The lever automatically returns to the up position when it is released. See Fig. 100, [Right-Hand Panel Dash Controls](#). The lever can be partially or fully applied, but in any partially on position it will be overridden by a full application of the service brake pedal.



- | | |
|-------------------------------|--------------------------|
| 1. Parking Brake Control | 3. Hazard Warning Switch |
| 2. Trailer Air Supply Control | 4. Trailer Brake Control |

Fig 100, Right-Hand Panel Dash Controls

5.06.04 Automatic Traction Control (ATC) Spin Switch



NOTICE:

The ATC spin feature is intended to be used under specific slippery conditions that require momentary increased wheel spin. Using this option for an extended period of time may damage the vehicle brake system.

Pressing the ATC SPIN switch shown in Fig. 101, [ATC SPIN Switch](#) shuts ATC off and allows drive wheel spin. Pressing the switch again, or cycling the ignition key, cycles the system back to normal operation.

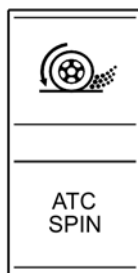

03/02/2016

f611333

Fig 101, ATC SPIN Switch

5.07 Powertrain Controls

5.07.01 Aftertreatment System Regen Switches

NOTE: See [14.01 Greenhouse Gas Emissions and Fuel Consumption Standards](#) for detailed information about the operation of the regeneration (regen) switches and the aftertreatment system (ATS).

Regen may be started manually with the optional digital switch in the ICU. See Fig.102, [Regen Start Digital Switch](#).



Fig 102, Regen Start Digital Switch

Some vehicles may be equipped with a regen inhibit switch. See Fig.103, [Regen Inhibit Switch](#). To stop a regen in progress or prevent the start of a regen, press the upper half of the switch. Regen is delayed until the switch is no longer active.

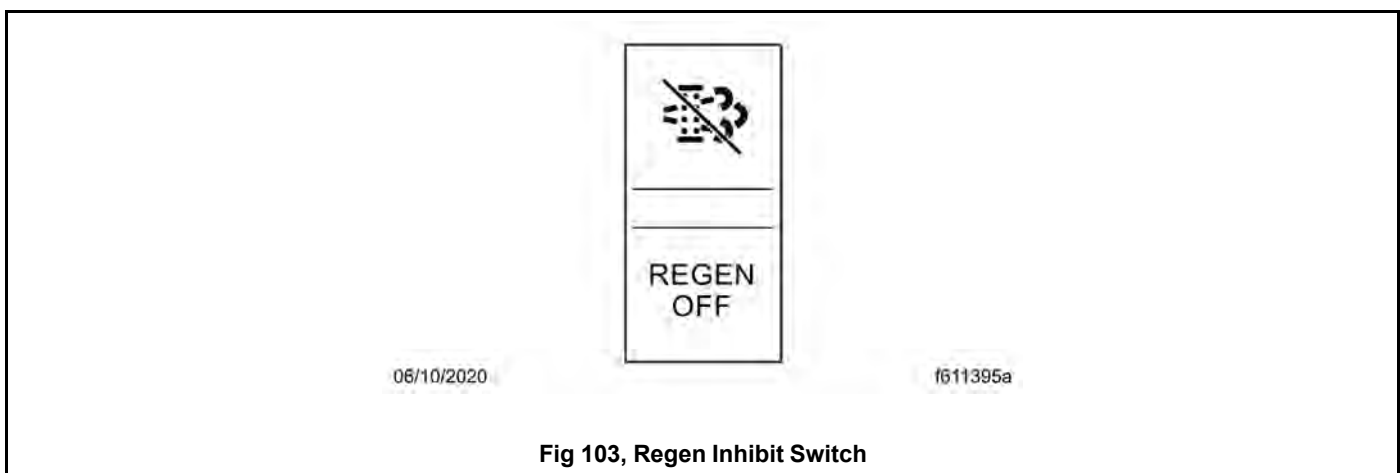
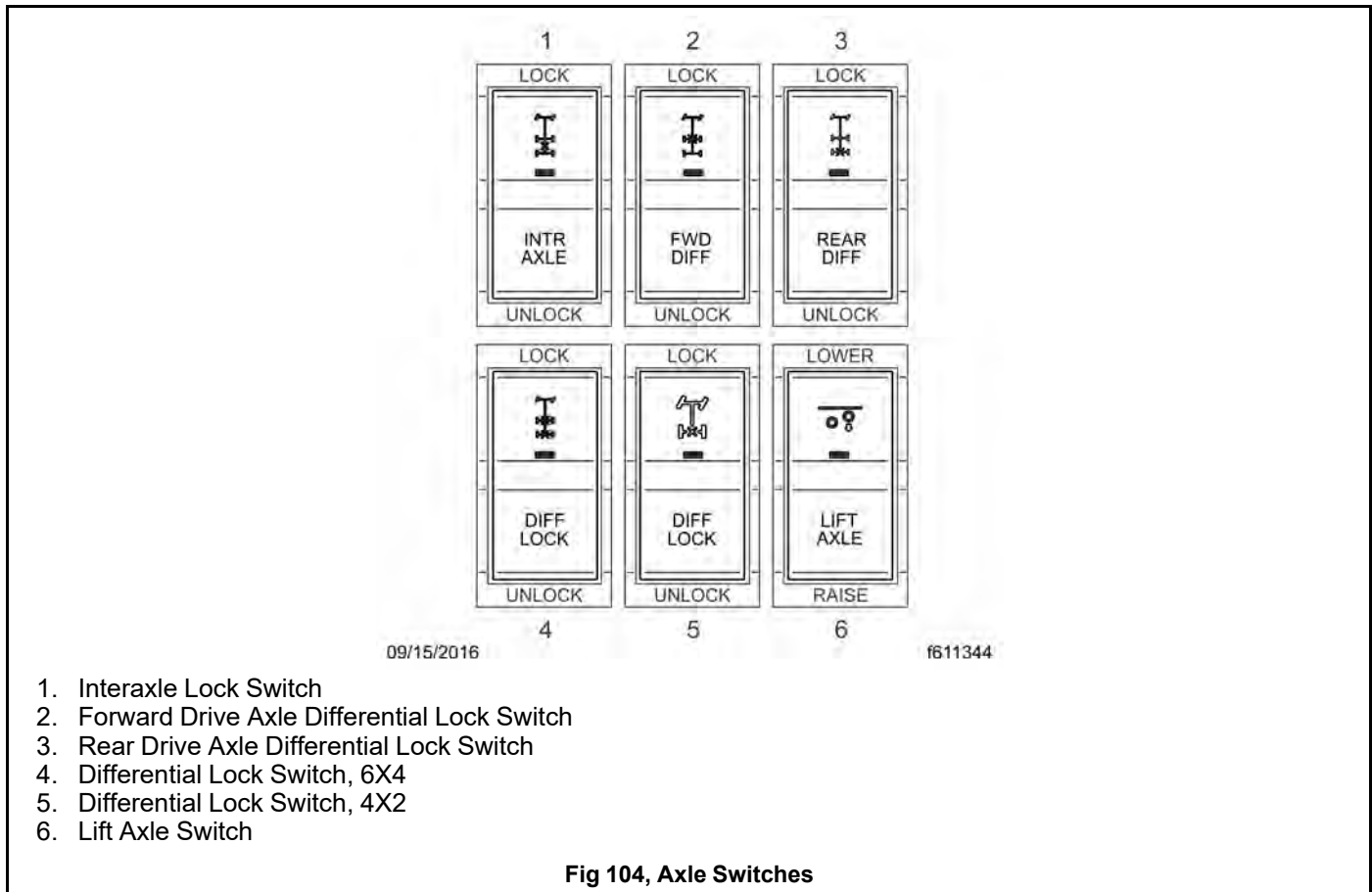

Fig 103, Regen Inhibit Switch

5.07.02 Axle Switches

Some vehicles are equipped with an interaxle differential lock switch and/or a switch for each driver-controlled differential lock (DCDL). See Fig. 104, and/or a switch for a driver-controlled differential lock (DCDL). See Fig. 104, [Axle Switches](#).

For more information about differential locks and using them for traction control, see [17.01.01 Drive Axles With Differential Lock Drive Axles](#).



5.07.03 Engine Brake Switches

NOTE: See [12.01.01 Air Brake System, General Information](#) Brake Systems, for detailed information about engine brake operation.

When vehicle braking is required on good road conditions, the engine brake may be used in conjunction with the service brakes. There is no time limit for operation of the engine brake. However, an engine brake does not provide the precise control of, and is not a substitute for, service brakes.

The engine brake control is located on the right-hand steering-column-mounted lever. At the top position, the engine brake is off, and at the three lower positions, the brake is on and the intensity (low, medium, high) increases with each step down. See Fig. 105, [Engine Brake Positions](#).

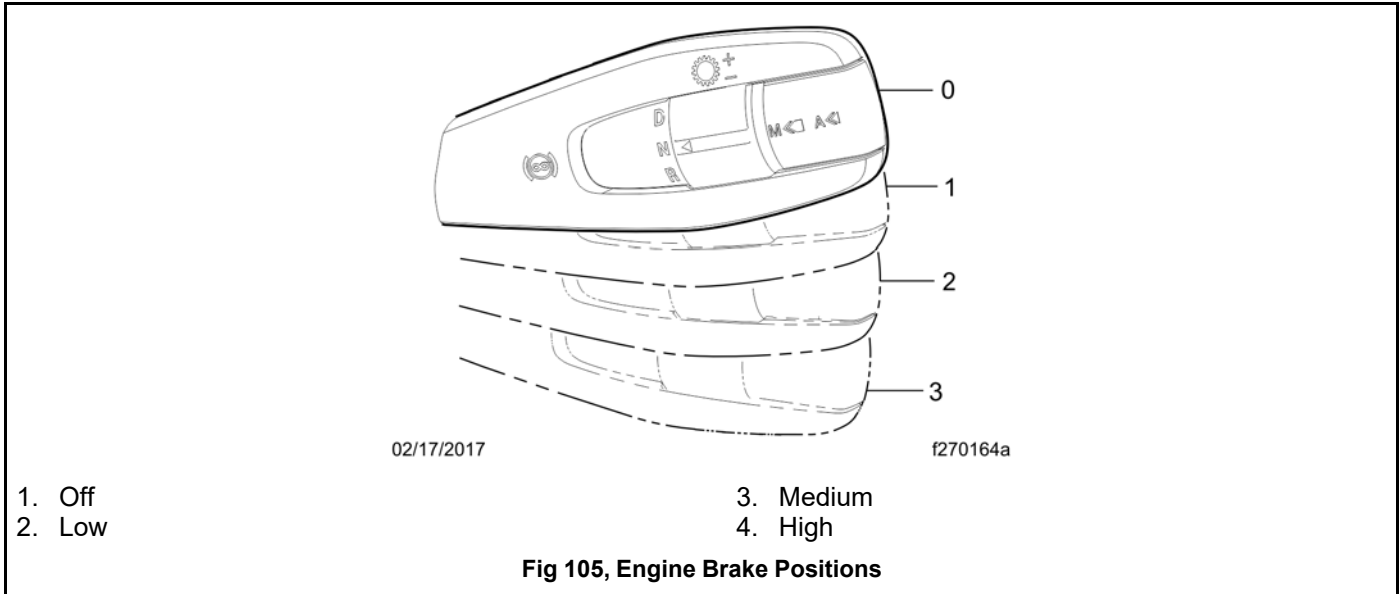

5.07.04 Engine Fan Switch

The engine cooling fan can be turned on by the engine fan switch.

To turn the engine fan on, press the upper half of the switch. The fan will continue to operate for a set amount of time and then turn off unless the coolant temperature is high enough to continue fan operation. To turn the fan off before the set time period ends, press the lower half of the switch. See Fig.106, [Engine Fan Switch](#).

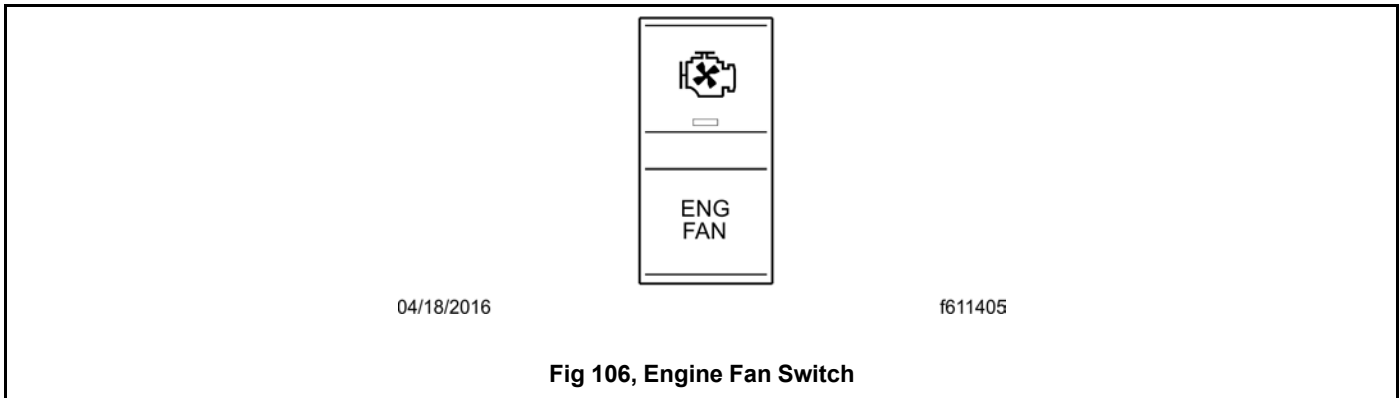

5.07.05 Hill Start Aid Override Switch

Some vehicles are equipped with a hill start aid (HSA) feature to prevent the vehicle from rolling while on steep grades and to allow for a controlled launch. HSA delays the release of the service brakes until enough torque is available to begin moving the vehicle forward, for a maximum of 3 seconds. HSA is "on" by default. It can be turned off by pressing and releasing the HSA override switch on the dash. See Fig.107, [Hill Start Aid Override Switch](#).



Fig 107, Hill Start Aid Override Switch

5.07.06 Power Take-Off (PTO) Switch

To activate the PTO function, press the upper half of the switch. Press the lower half of the switch to deactivate the PTO function. See Fig.108, [PTO Switch](#).

PTO can also be activated using the digital switch in the ICU.



WARNING:

To avoid injury, do not install a PTO that is not Detroit Diesel approved onto a Detroit™ Transmission. Use of a non-Detroit Diesel approved PTO with a Detroit Transmission could result in unintended operation which could lead to severe personal injury.

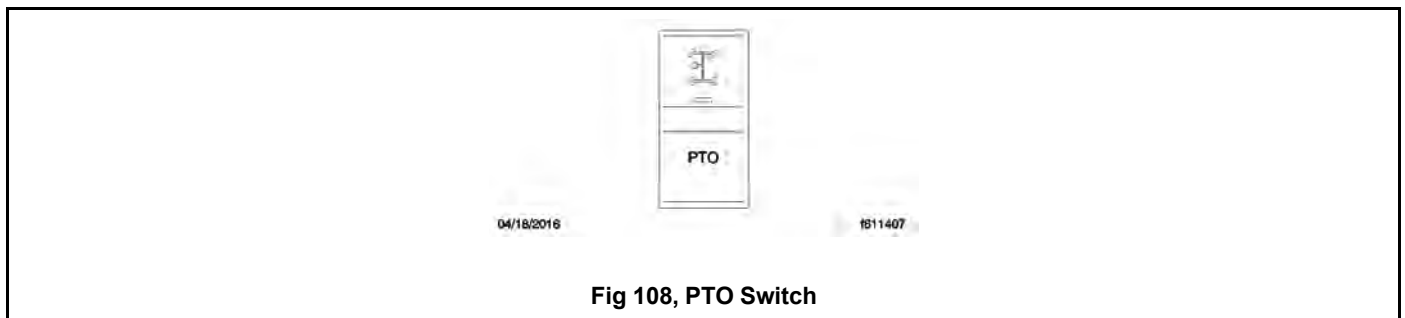

Fig 108, PTO Switch

5.07.07 Transmission Controls

Detroit™ Automated Transmissions

NOTE: See [15.01.01 Direction Switch](#) Automated and Automatic Transmissions for automated transmission operating instructions.

Vehicles with automated and automatic transmissions use the multifunction control shown in Fig.

[109, Automated/Automatic Transmission Multifunction Control](#). This control moves in two directions and has two switches. It is used to request manual shifts, change shift mode, set engine brake levels, and control specialty engine brake functions.

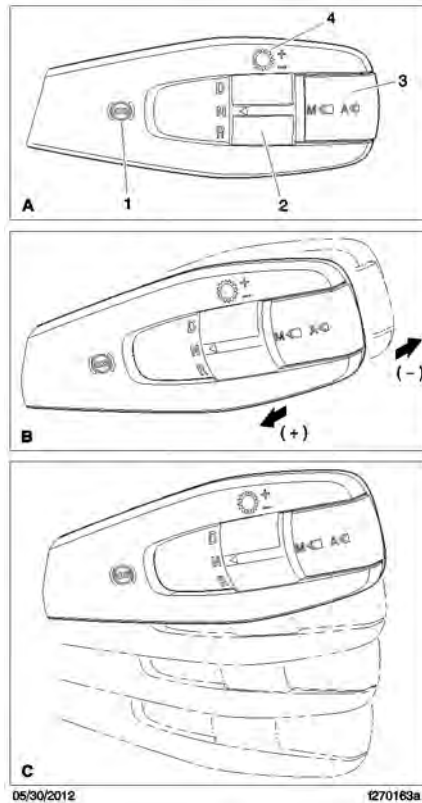

- A. Front View
- B. Shift Up/Down Requests
- C. Four positions for engine brake settings
- 1. Engine Brake Symbol
- 2. Drive/Neutral/Reverse Switch
- 3. Shift Mode Switch (Economy/Performance/Manual)
- 4. Gear Shift Symbol

Fig 109, Automated/Automatic Transmission Multifunction Control

Manual Transmissions

NOTE: See [16.01.01 General Information](#) Manual Transmissions and Clutch, for manual transmission operating instructions.

If equipped, a transmission range control and splitter valves are attached to the gear shift knob.

The range-preselection lever allows the selection of the low or high range for each transmission ratio. It is used once during an upshift sequence and once during a downshift sequence.

Dependent on the transmission model, some ratios can be split using the splitter-control button.

5.08 AWD Controls

5.08.01 Front Axle Transfer Case Switch



CAUTION:

Stop the vehicle, set the parking brake, and put the transmission in neutral before engaging the front axle. Failure to do so may cause damage to the transfer case and the driveline.

The front axle transfer case switch directs power to the front axle. To engage the front axle, press the upper half of the rocker switch. To disengage it, press the lower half of the switch. See Fig.110, [Front Axle Transfer Case Switch](#).

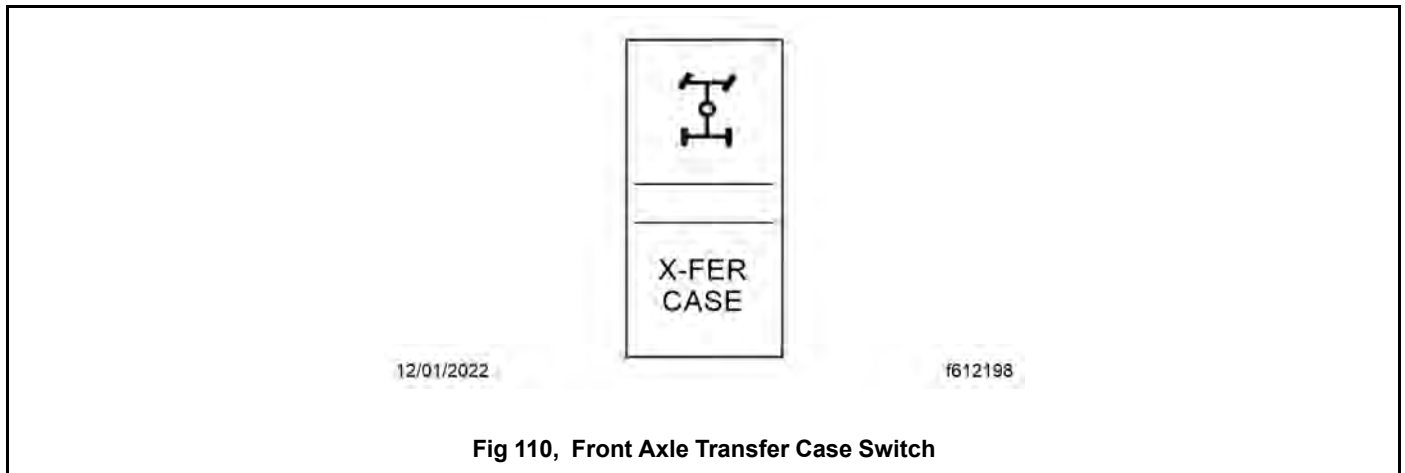

5.08.02 Front Axle Transfer Case Range Switch



CAUTION:

Stop the vehicle and set the parking brake before selecting the neutral (N) position on the transfer case range switch to prevent the vehicle from rolling, and causing damage and/or personal injury.

Use the range switch when the steering axle has been engaged.

There are two possible transfer case range switches: a two-position rocker switch with LO and HI range, or a three-position switch that has a third, neutral (N) position, for vehicles with a PTO unit. See Fig. 111, [Transfer Case Range Switches](#).

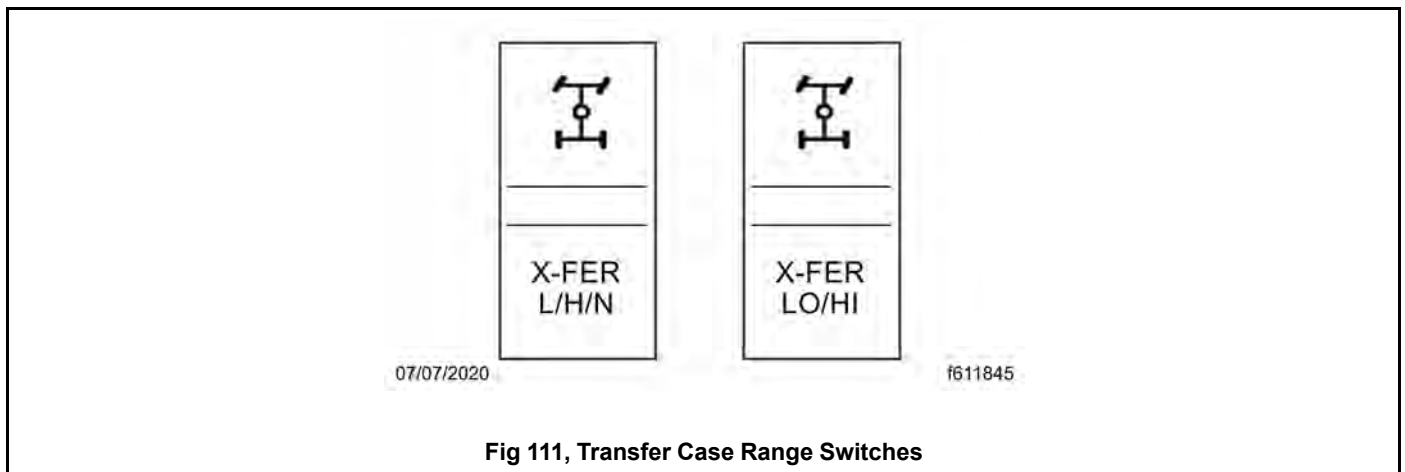

5.09 Other Dash-Mounted Controls

Air Suspension Height Control Switch

**NOTICE:**

Do not operate the vehicle over uneven ground such as ramps, speed bumps, curbs, etc. with the air springs deflated. Doing this may lead to air bag separation from the piston, preventing the suspension air springs from re-inflating.

The air suspension height control switch is used to adjust the vehicle height to aid in coupling or uncoupling from a trailer. See Fig.112, [Air Suspension Height Control Switch](#). Setting the switch to LOWER deflates the air springs to lower the rear of the vehicle. In the NORMAL position, the air springs inflate to raise the rear of the vehicle to normal ride height.

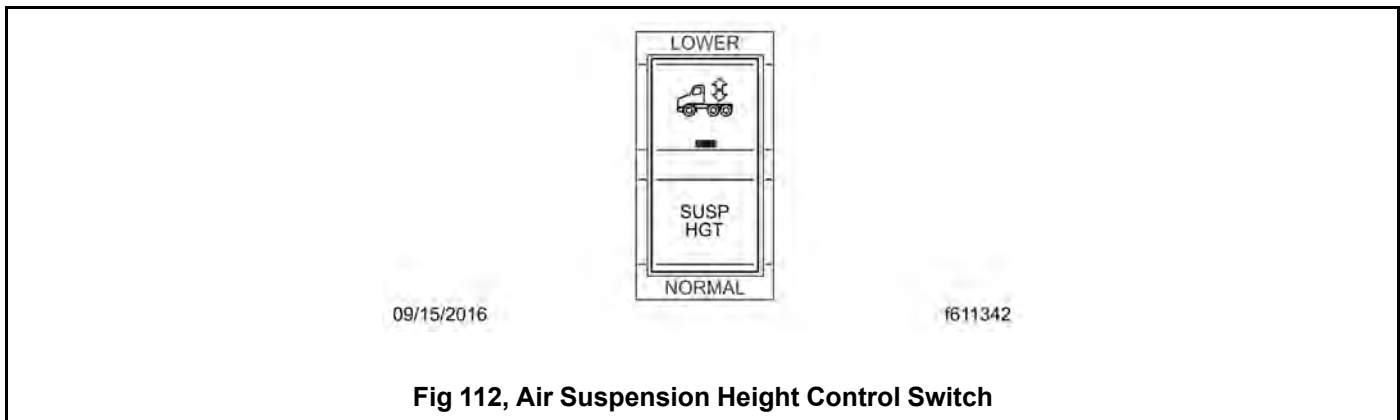
**NOTICE:**

Never exhaust air from the suspension while driving. When the air is exhausted, the suspension will not absorb road shocks, and components may be damaged.

A red LED in the switch is illuminated when the suspension is deflated.

6.01 Cab Amenities	122
6.02 Interior Lighting Controls	123
6.03 HVAC Controls	126
6.04 Infotainment Controls	128
6.05 Windows	132
6.06 Mirrors	133
6.07 Seats - General Information	134
6.08 Sitting Posture	136
6.09 ISRI Premium High Back Seat	137
6.10 ISRI Basic High Back Seat	140
6.11 Sears C-2 Plus Seat	142
6.12 Bench Seats	144
6.13 Seat Belts	145
6.13.01 Seat General Information	145
6.13.02 Seat Belt Operation	146
6.14 RollTek Rollover Protection System	149

6. Cab Features

6.01 Cab Amenities

See Fig. 113, [Dash Features](#) for standard and optional dash features.



1. Steering Wheel Pod LH
2. Steering Wheel Pod RH
3. Reading Lamp
4. Trailer Air Supply

5. Hazard Lamps Switch
6. Power Outlets
7. Cup Holders
8. Park Brake

Fig 113, Dash Features

Standard Features

Standard features include:

- An AM/FM/WB world tuner radio mounted in the dash with Bluetooth®, USB, and auxiliary inputs.
- 12V power outlet in the dash.
- Storage pockets molded into the driver and passenger doors.
- Two cup holders.
- Slot for tablet or phone. See Fig. 114, [Tablet Slot](#) .

Optional Features

Optional features include:

- AM/FM/WB world tuner radio with SiriusXM, iPod interface, Bluetooth, and USB input
- An installed CB radio or wiring for either a overhead or dash mounted CB.
- Two 12V power outlets in the dash or one 12V power outlet and one USB charger
- RAM mounted on dash or overhead console. See Fig.115, [Optional RAM](#).



Fig 114, Tablet Slot



Fig 115, Optional RAM

6.02 Interior Lighting Controls

Interior lighting includes dome lamps, console lamps, reading lamps, and courtesy lamps. See Fig. 116, [Interior Lamps](#) for location of the lamps.



1. Crew Cab Reading Lamp
2. Crew Cab Reading Lamp
3. Cab Dome Lamp
4. Overhead Console Lamps
5. Door Courtesy Lamps
6. Footwell Lamps

Fig 116, Interior Lamps

Lamps may be controlled using the menu screen of the ICU, dash switches, or by pressing on the lamp lens.

Dash-mounted switches are back lit to illuminate the text and icon on the switch. Press the upper half of the switch to turn the desired lamp(s) on or off. If the lights have a dimming function, hold the switch down to cycle the light between bright and dim.

Interior Lights

Door Courtesy Lamps

Each door contains a door entry courtesy lamp located on the bottom of the door pocket that illuminates when the door is opened, and stays on for a short time after both doors are closed.

Foot Well Lamps

If equipped, amber lamps illuminate both foot wells when the driver or passenger doors are opened. These lamps can also be activated with the foot-well light switch, shown in Fig.117, [Foot Well Light Switch](#).

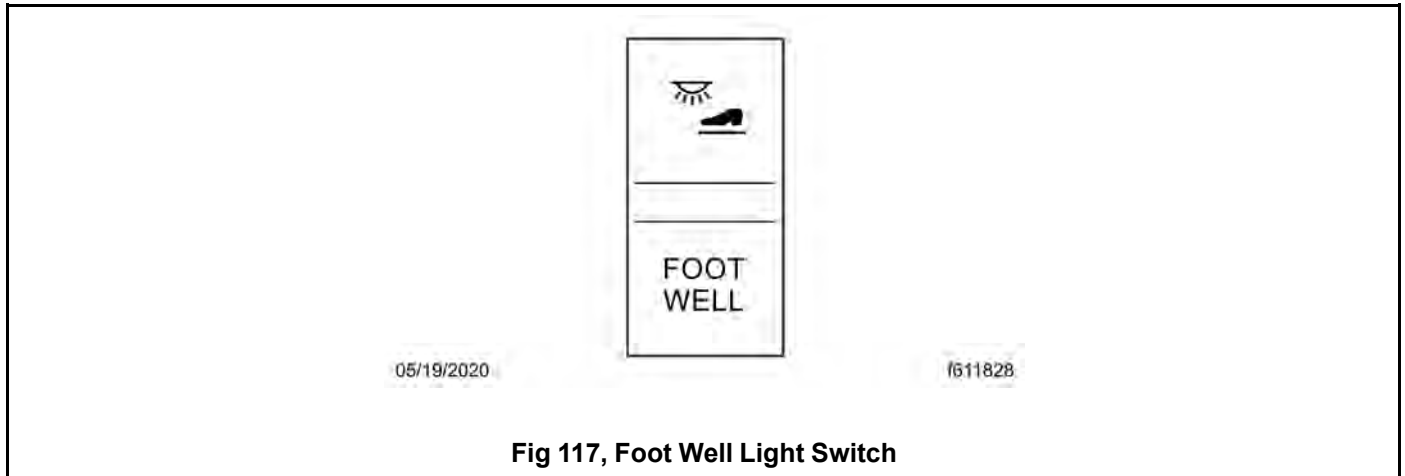

Cab Dome Lamp

In the day and extended cab, the cab dome lamp is at the midpoint of the cab ceiling; in a crew cab there is a second dome lamp near the cab back wall. The cab dome lamp illuminates when a door is opened and stays on for a short time after both doors are closed.

Press the lamp cover to turn it off or on.

Overhead Console Lamps

The overhead console lamps consist of two lamps with the form and function of the cab dome lamps, two reading lamps, and an amber lamp that provides ambient light for the center dash area.

The overhead console lights can be individually turned off and on by pressing on the lamp cover.

Dash Lights

The dash lighting adjusts automatically based on ambient lighting.

The brightness can be adjusted in either the 'Settings' menu or with an optional dash light switch as shown in Fig. 118, [Dash Light Switch](#).

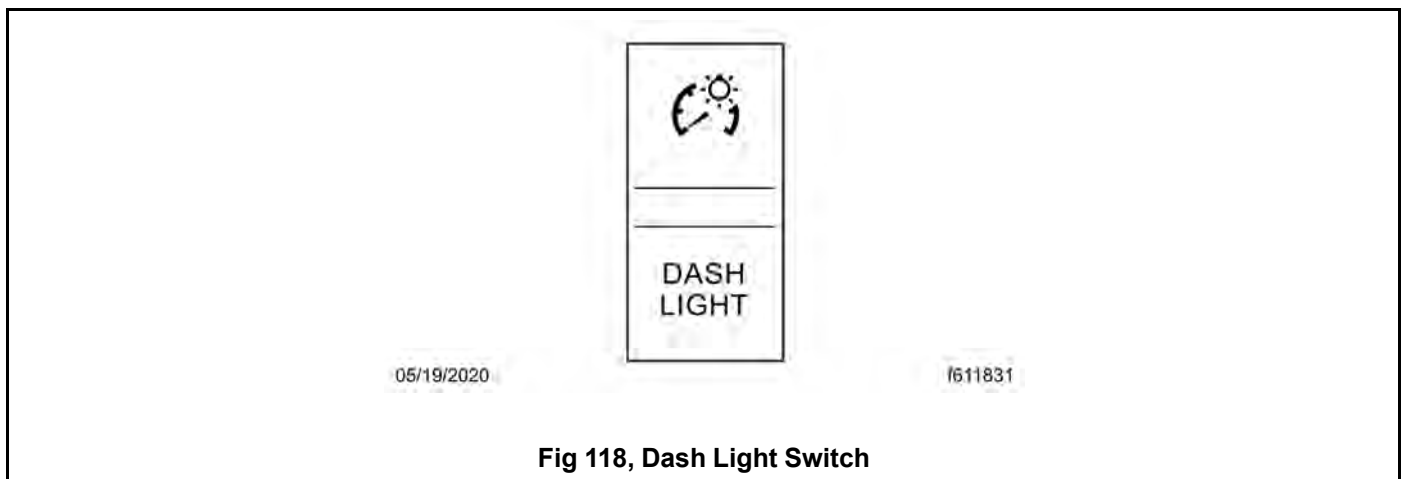

When using the dash light switch, the panel lights brighten and dim in 10 percent increments, depending on whether the upper half or the lower half of the switch is pressed. When the panel lights are turned on with the switch they default to the intensity that was last set.

Reading Lamps

An extended or crew cab has two to three reading lights above the back seat area. Press the switch on the rear of the light to turn it off or on.

Premium Lighting

Some vehicles are equipped with premium lighting which includes theater lighting. Theater lighting refers to the gradual illumination and dimming of the overhead and reading lamps when they are turned on and off.

6.03 HVAC Controls

Controls for the heating, ventilation, and air-conditioning system (HVAC) consist of a fan speed switch, an air vent selection switch, and a temperature control switch. On vehicles with air conditioning, the panel also contains a telltale LED and an air recirculation button as shown in Fig.119, [HVAC Climate Control Panel, Standard](#).

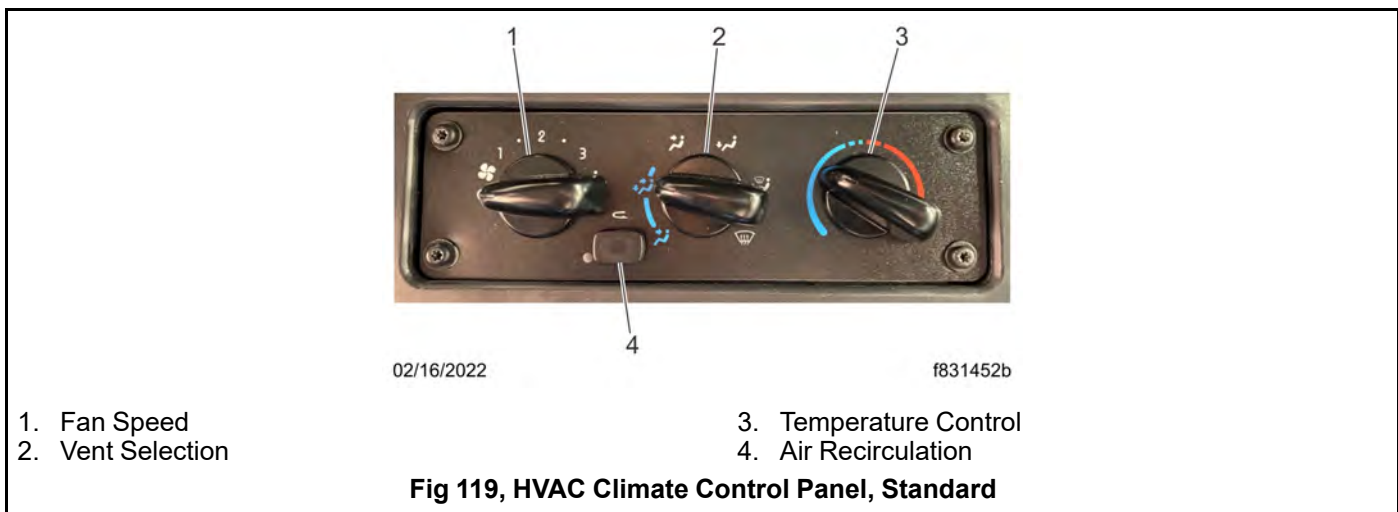

Fan Speed Switch

The fan speed switch controls the speed of the fan that forces fresh or recirculated air through the air outlets.

In the default mode fresh, or outside, air circulates through the heating and air conditioning system. If equipped with air conditioning, recirculation mode is available. This limits the amount of outside air entering the cab.

The fan has eight speeds.

Air Vent Selection Switch

The air selection switch allows you to control the flow of air through the face, floor, and defrost vents.

Before using any of the defrost modes, clear the screen at the base of the windshield if snow or ice is present.

With the intermediate modes between each telltale, there are nine modes to choose from on a system without air conditioning, as shown in Fig.120, [Air Selection Switch Without Air Conditioning](#) and eleven modes to choose from in a system with air conditioning as shown in Fig.121, [Air Selection Switch With Air Conditioning](#).

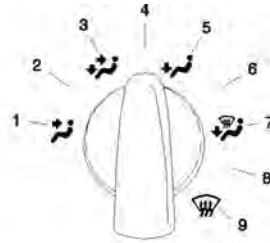

06/17/2003

1831455

1. Face Mode
2. $\frac{3}{4}$ Face, $\frac{1}{4}$ Floor Mode
3. $\frac{1}{2}$ Face, $\frac{1}{2}$ Floor Mode
4. $\frac{1}{4}$ Face, $\frac{3}{4}$ Floor Mode
5. Floor Mode
6. $\frac{3}{4}$ Floor, $\frac{1}{4}$ Defrost Mode
7. $\frac{1}{2}$ Floor, $\frac{1}{2}$ Defrost Mode
8. $\frac{1}{4}$ Floor, $\frac{3}{4}$ Defrost Mode
9. Defrost Mode

Fig 120, Air Selection Switch Without Air Conditioning

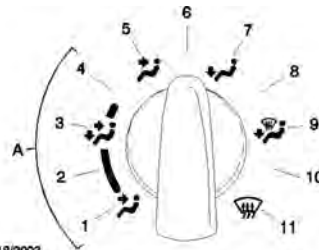

06/18/2003

1831462

Fig 121, Air Selection Switch With Air Conditioning

Temperature Control Switch

Turn the switch to the left (counterclockwise) for cool air, or to the right (clockwise) for hot. There are 21 positions on the temperature control switch.

Recirculation Mode

Press the recirculation button to prevent dusty or smoky air from entering the cab or to decrease the time required to cool or heat the cab interior during extreme outside temperature conditions. When recirculation mode is active the LED next to the recirculation button shown in Fig.119, [HVAC Climate Control Panel, Standard](#) illuminates.

To prevent the buildup of odors or oxygen depletion inside the cab, after 20 minutes the system switches from full recirculation mode to partial recirculation mode for five minutes. The system cycles from full to partial recirculation as long as the mode is enabled.

Recirculation mode is not available when the air vent selection is set to partial or full defrost mode.

Air Conditioning

The four air conditioning modes are marked in blue on the air vent selection switch.

IMPORTANT: Operate the air conditioner at least five minutes each month, even during cool weather. This helps prevent drying and cracking of the refrigerant compressor seals and reduces the chance of refrigerant leaks in the system.

NOTE: The heating and air conditioning system has a brushless blower motor with a protection or shutdown mode to prevent damage due to overheating and overcurrent conditions. If the brushless blower motor goes into a protection mode, the motor operates at a slower speed. If the overheating or overcurrent condition continues, the motor shuts down and stops completely. The motor resumes normal operation after the motor has cooled or the overcurrent condition has been resolved. It is necessary to cycle the fan switch off, and then on, to reset the motor. If the problem appears repeatedly, take the vehicle to a Freightliner dealer or authorized service outlet for repairs.

6.04 Infotainment Controls

NOTE: Features of the infotainment system depend on cellular and satellite reception. In certain situations, such as driving through tunnels, mountains, or parked in multistory parking lots, reception may be impaired due to interference or there may be no reception at all.

Safety Information

**WARNING:**

A driver can be distracted from the traffic situation if operating communication equipment integrated in the vehicle when driving, possibly causing loss of control of the vehicle resulting in property damage, physical injury, or death.

Only operate this communication equipment when the road and traffic situation permits, otherwise stop and operate the equipment with the vehicle stationary.

The driver must observe the legal requirements of the country the vehicle is driving through when operating the infotainment system.

Wearing polarized sunglasses may impair or limit your ability to read the display.

General Infotainment Information

The standard infotainment system options consist of AM/FM/WX Radio with USB and auxiliary input with smart phone integration via Bluetooth®.

ICUC Infotainment Screens

Use the menu up and menu down arrows shown in Fig. 122, [Steering Wheel Left-Hand Switch Pod-ICUC](#) to navigate between the Audio and Telephone infotainment screens:

1. Audio (AM/FM/WX, USB, AUX). See Fig. 123, [Infotainment: Radio-ICUC](#).
2. Telephone, showing signal strength, battery level, phone number, and active call length. See Fig. 124, [Infotainment: Active Call-ICUC](#).



08/14/2019

f611352f

- 1. Volume Increment Up
- 2. Menu Right
- 3. Volume Increment Down
- 4. Menu Down
- 5. Back Button
- 6. Menu Left
- 7. Menu Accept (OK)
- 8. Menu Up

Fig 122, Steering Wheel Left-Hand Switch Pod-ICUC

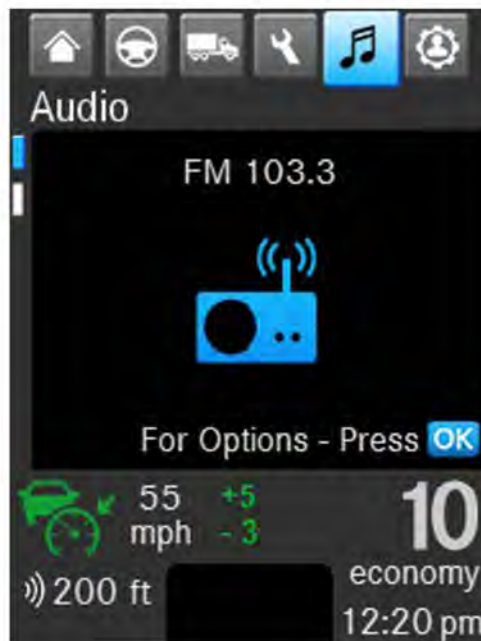

04/25/2019

f611630

Fig 123, Infotainment: Radio-ICUC



Fig 124, Infotainment: Active Call-ICUC

ICUC Radio Controls

Radio stations, presets, and other audio sources can be accessed under Audio.

1. Select the single bar note icon to open the infotainment menu. The last infotainment menu accessed opens.
2. If not on the Audio screen, press the Up arrow in the left-hand steering wheel switch pod to move to this screen.
3. Press OK on the left-hand steering wheel switch pod to access Audio Settings.
4. Use the right and left arrows to navigate from one audio source to another—from radio to USB for example.
5. Use the up and down arrows to navigate through an audio options list of choices. Choices can vary depending on the number of audio sources available and saved presets.
6. Press OK on the left-hand steering wheel switch pod to select an audio source. The audio source is selected.
7. Press the back button to return to the main Audio screen.

Physical Radio Controls

ICUC volume up and down switches are on the left-hand switch pod as shown in Fig.

122, [Steering Wheel Left-Hand Switch Pod-ICUC](#) The radio itself also has a volume knob, as shown in Fig. 125, [Radio](#) which, along with the radio's other physical controls, a passenger would find easier to access.

NOTE: This is a brief overview of DEA710 radio controls; see the owner's manual for a full description.

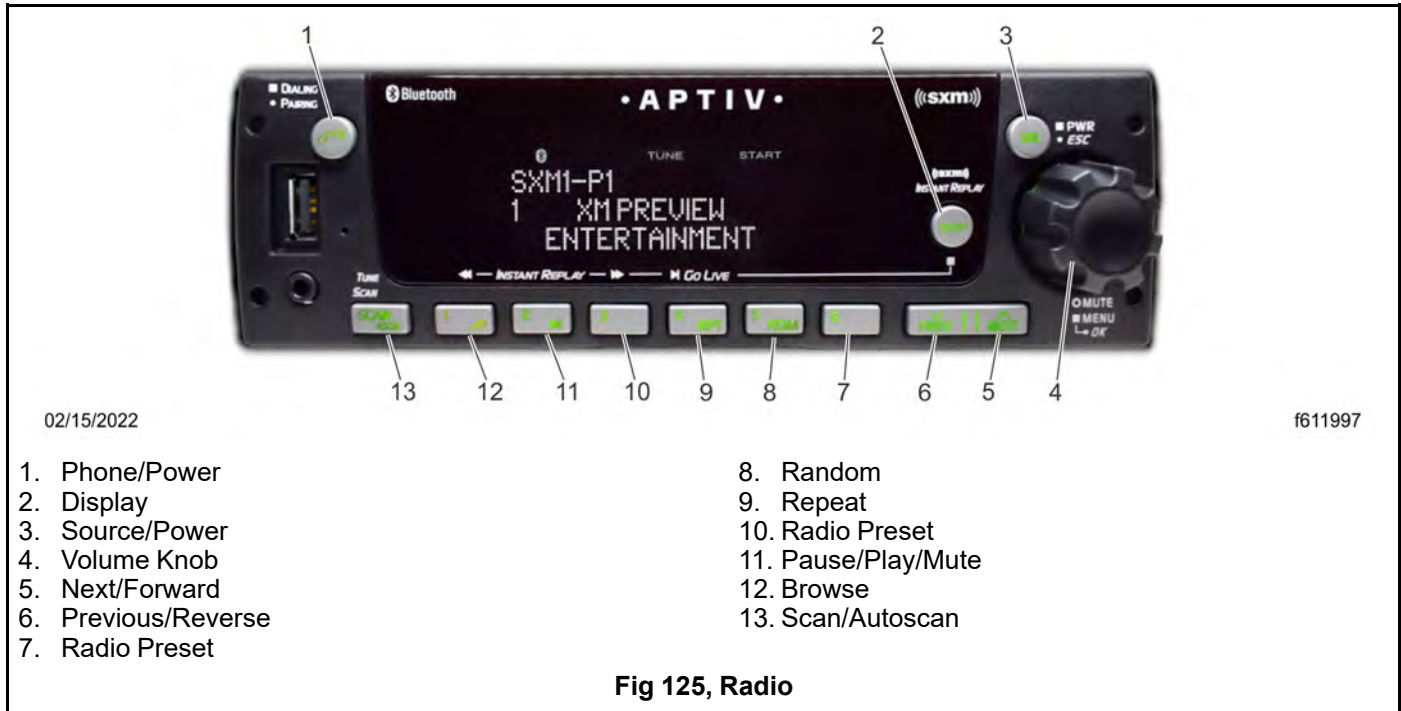

Phone/Power : Press to show the Bluetooth menu. When a phone is connected, press to accept an incoming call, or long press to display the dial menu.

Display : If the ignition is off, pressing lights up the radio clock for a few seconds; if the ignition is on, pressing changes the source display.

Source/Power : Press to turn the radio on/off and toggle between sources (AM, FM, Bluetooth, etc.). If Bluetooth is active, press to reject/cancel a call.

Volume Knob : Rotate to increase/decrease audio volume, press for less than three seconds to mute audio.

Next/Forward : Press to select the next track/station, press and hold for fast forward.

Previous/Reverse : Press to select the previous track/station, press and hold for fast reverse.

Random : Press to play tracks randomly. Press again to stop.

Repeat : Press to repeat the current track. Press again to stop.

Pause/Play/Mute : Press to pause/unpause a track or mute the current station.

Browse : Press to navigate and play content on an attached device.

Scan/Autoscan : A long press scans stations and stores the six strongest signals to the radio presets until the radio is powered off or the source is changed.

Weather Radio

Weather Radio is an option under the Audio menu.

Weather radio channels WX1 through WX7, corresponding to frequencies 162.400 MHz through 162.550 MHz, are the standard weather radio channels used by NOAA Weather Radio in the United States, Weatheradio Canada/Radiom  t   Canada in Canada, and SARMEX in Mexico. Each system consists of a nationwide network of radio stations broadcasting official weather warnings, watches, advisories, forecasts and other non-weather related hazard information including news on natural disasters (earthquakes, avalanches, floods), environmental hazards (oil spills, chemical releases), and public safety messages (AMBER alerts, network outages). All services operate 24 hours a day, 7 days a week.

The average range for reception from a transmitter is approximately 40 miles (60 km). The National Weather Service operates more than 1000 transmitters.

Phone Controls

Telephone is the second screen under infotainment. The main telephone screen shows the connected phones current signal and battery strength. If a call is in progress it displays the phone number and call length.

1. Select the single bar note icon to open the infotainment menu. The last infotainment menu accessed opens.
2. If not on the Telephone Screen, use the down arrow in the left-hand steering wheel switch pod to move to this screen.
3. When on the Telephone screen, select OK on the left-hand steering wheel switch pod to access Telephone Settings.
4. Use the right and left arrows to navigate from one telephone setting to another—from contacts to missed calls for example.
5. Use the up and down arrows in the left-hand steering wheel switch pod to navigate through the current Telephone Settings list of choices.
6. Press OK on the left-hand steering wheel switch pod to choose an option.
7. Press the back button on the left-hand steering wheel switch pod to return to the main screen.

6.05 Windows

Power windows are standard on 108SD Plus and 114SD Plus vehicles. With power windows, the driver's door has switches mounted in the top of the door, as shown in Fig.126, [Driver's Door Switches](#), that separately control the driver and passenger windows. Additionally, the passenger door has a switch mounted in the top of the door that controls the passenger-side power window as shown in Fig.127, [Passenger's Door Switches](#).



1. Door Lock Switch
2. Driver-Side Window Switch
3. Mirror Heat Switch
4. Mirror Selector Switch
5. Mirror Directional Switch
6. Passenger-Side Window Switch

Fig 126, Driver's Door Switches



1. Passenger-Side Window Switch
2. Door Lock Switch

Fig 127, Passenger's Door Switches



CAUTION:

There is no anti-pinch protection when the window is almost closed. Be sure to clear all objects from the window before closing.

The window switches have three positions: lower window, neutral, and raise window. Press forward on the switch to lower the window. Hold the switch down in the forward position for approximately one second to activate the express function; and the window continues to roll down after the switch is released. Press the switch in the rearward position to raise the window.

6.06 Mirrors

The standard outside mirrors are mounted on the door frame. There is a primary heated power rear view mirror and a convex mirror.

The power mirrors are controlled with a left-hand or right-hand mirror selector switch, and a directional switch. Select the left (driver) mirror, or the right (passenger) mirror using the selector switch. The mirror can then be adjusted by pressing the directional switch arrow for the direction the mirror should be adjusted.

The outside door mirrors can be heated to keep them clear of fog, frost, and ice. To heat the mirrors, press the outboard part of the mirror heat switch on the door. See Fig.128, [Driver's Door Switches](#). When the mirror heat switch is on, an amber indicator light on the switch illuminates.



1. Door Lock Switch
2. Driver-Side Window Switch
3. Mirror Heat Switch
4. Mirror Selector Switch
5. Mirror Directional Switch
6. Passenger-Side Window Switch

Fig 128, Driver's Door Switches

6.07 Seats - General Information



WARNING:

Keep hands, tools, and other objects away from the scissor points under the seats. Failure to do so could cause personal injury.

Unless otherwise noted, all seat adjustments should be made while seated and before the engine is started.

Due to the high degree of adjustability found in high-back air suspension seats, it is possible to set the seat back recline adjustment and the seat slide adjustment in such a combination that the seat back will come into contact with the rear wall of the cab. It is the responsibility of the driver to adjust the seat to prevent damage to the seat and the cab interior.

All controls for adjusting air suspension seats are located within easy reach of the occupant.

All adjustment controls for a suspension seat are located on the seat base.

The following is a description of adjustments that are available on one or more seats. Not all seats have all of the adjustments listed below.

1. Seat Slide (forward-and-backward): When this adjustment is made, the entire seat moves forward or backward on its track. See Fig.129, [Seat Slide Adjustment and Isolator Feature](#).

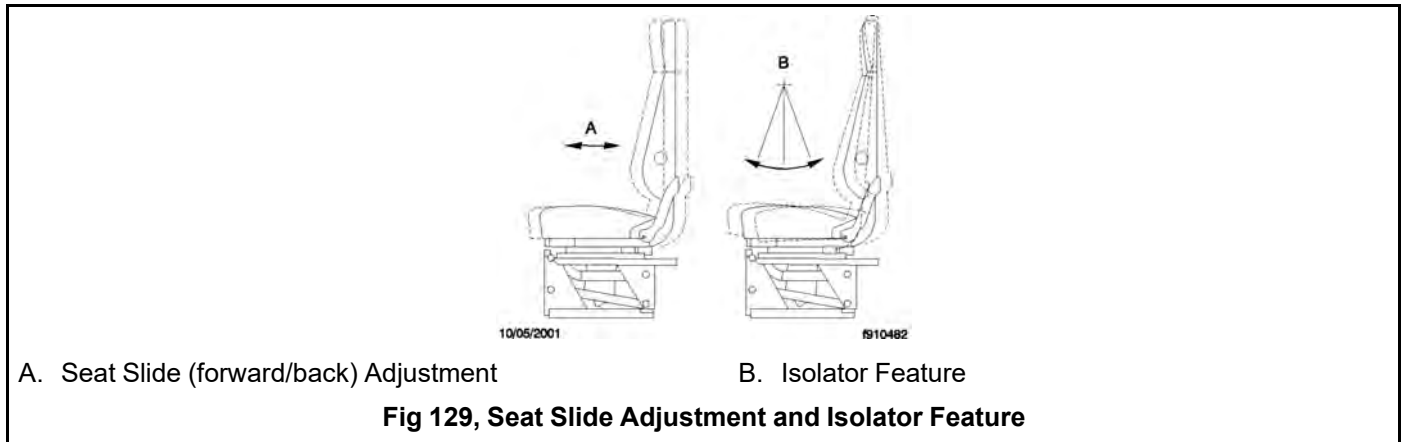

2. Isolator: This feature (also referred to as back-slap isolator or Chugger-Snubber®) reduces the amount of road shock by isolating the occupant from the motion of the vehicle, and allowing the upper seat to move in a simple pendulum motion. Whenever the isolator is not desired, it can be locked out. See Fig. 129, [Seat Slide Adjustment and Isolator Feature](#).
3. Lumbar Support: Lumbar support changes the shape of the seat back to give more or less support to the occupant's lumbar (lower back) area. This adjustment is either mechanical or air controlled, depending on make and model of the seat. See Fig.130, [Lumbar Support and Headrest Adjustment](#).

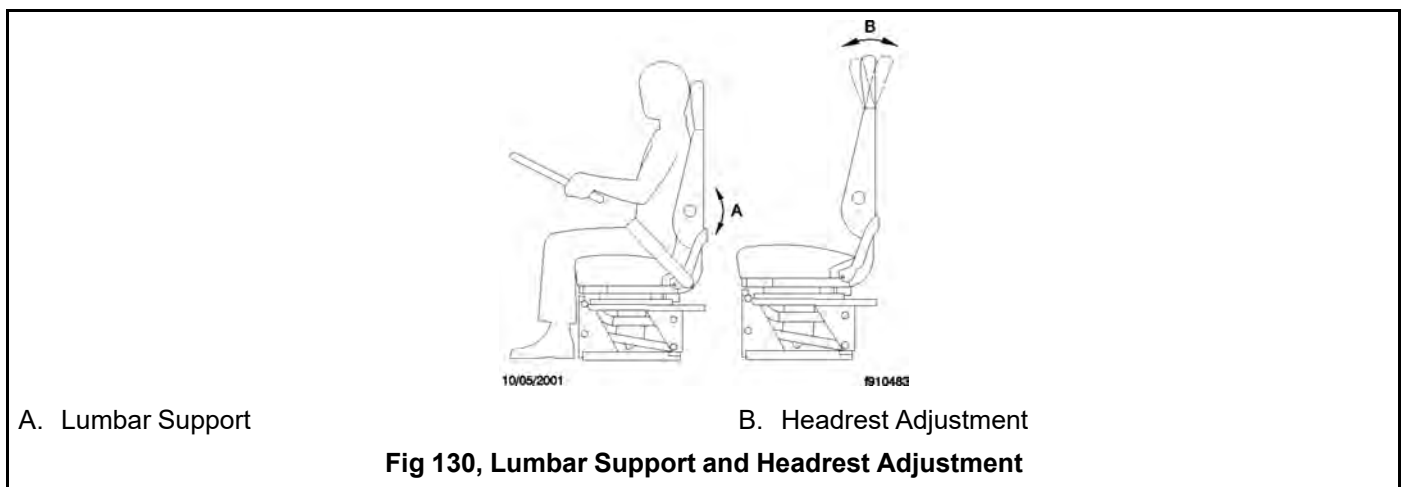

4. Headrest: When this adjustment is made, the upper part of the back cushion changes angle to provide head and upper back support. See Fig.130, [Lumbar Support and Headrest Adjustment](#).
5. Backrest Tilt: This adjustment pivots the backrest forward or backward. See Fig.131, [Cushion Tilt Adjustments](#).

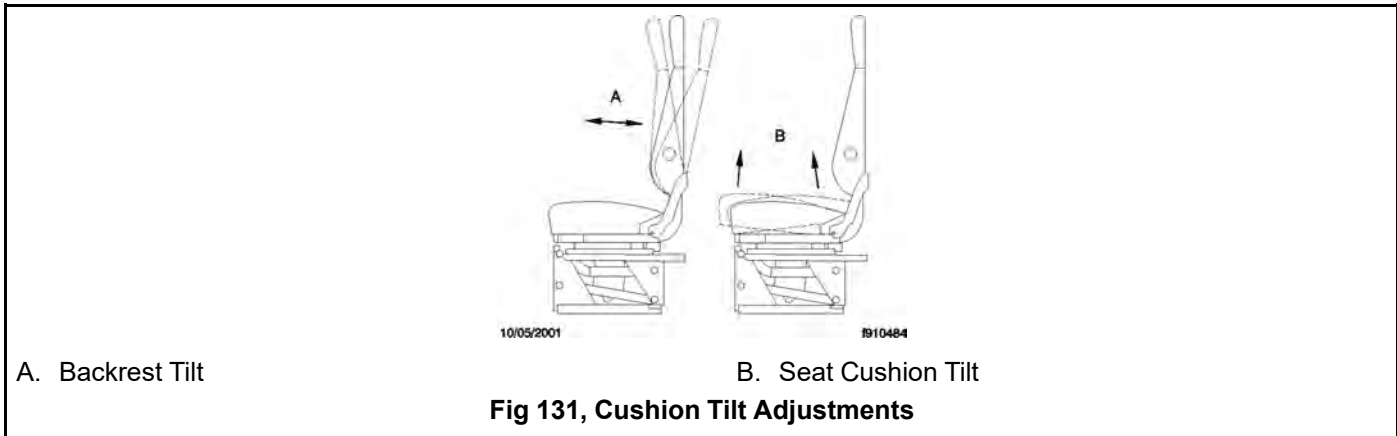

6. Seat Cushion Tilt: This adjustment raises or lowers the front and/or back of the seat bottom cushion. This adjustment is easier to perform when all weight is removed from the seat. See Fig.131, [Cushion Tilt Adjustments](#).
7. Seat Tilt: When this adjustment is made, the seat assembly, both backrest and seat cushion, tilts forward or backward. See Fig.131, [Cushion Tilt Adjustments](#).
8. Ride Height Adjustment: The entire seat moves up or down when adjusting the ride height. The adjustment is either manual or air controlled, depending on the make and model of the seat. See Fig.132, [Ride Height Adjustment](#).



9. Damper: While sitting on the seat, a leveling valve sets the seat in the center of the ride zone. When the damper is adjusted properly under normal driving conditions, the seat should not top or bottom against the limits of the vertical travel.
10. Ride Firmness: A firmer ride gives a better feel for the road but less protection against unevenness in the road surface. A softer ride smooths out the bumps.

6.08 Sitting Posture

Before driving, adjust the seat to support good sitting posture as shown in Fig.133, [Correct Seating Posture](#). Good posture supports the safe operation of the vehicle and the driver's fitness and comfort. When correctly seated, all instruments and controls should be within easy reach and the driver should have a clear view of the road and mirrors.

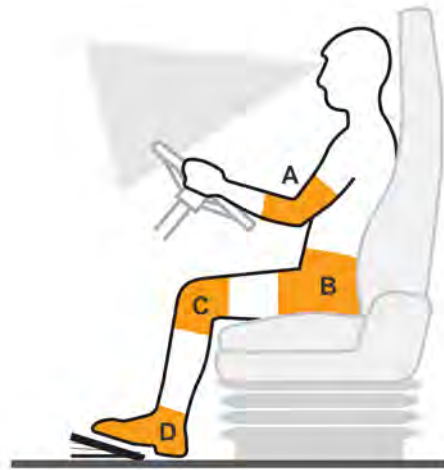

12/01/2021

f910833

- A. Adjust the steering wheel and seat to achieve a 95° to 135° angle at the elbow joints.
- B. Adjust the bottom cushion to achieve a 100° to 115° angle at the hip joints.
- C. Adjust the seat height to achieve a 110° to 120° angle at the knee joints.
- D. Adjust the seat to achieve a 90° angle with the feet.

Fig 133, Correct Seating Posture

6.09 ISRI Premium High Back Seat

NOTE: The seat should only be adjusted when the vehicle is parked with the park brake on.

The seat is designed to hold a maximum driver's weight of 330 lbs.

The ISRI Premium seat controls are shown in Fig.134, [ISRI Premium High Back Seat](#).



12/02/2021

f910682f

- | | |
|------------------------|--------------------------|
| 1. Backrest Tilt | 5. Forward/Back Isolator |
| 2. Back Support | 6. Seat Extension |
| 3. Height Adjustment | 7. Forward/Back Slide |
| 4. Isolator Adjustment | 8. Seat Tilt Lever |

Fig 134, ISRI Premium High Back Seat

1. **Backrest Tilt:** Pull the handle out completely and lean back or forwards to adjust the backrest tilt. Release the handle when the correct position is achieved. The backrest has a 52 degree range of movement.
When adjusted, the backrest inclination should allow the driver to reach the steering wheel with angled arms.
2. **Back Support:** There are two switches that control the back areas of the seat. Making changes to a driver's sitting position from time to time helps prevent driver fatigue and improves posture.

2.a Lumbar Support:

Press the forward button to inflate the cushion highlighted in Fig.135, [Lumbar Support](#) to increase support at the lower back. This moves the driver's spine into a double S shape and decreases pressure on the spine.



2.b Upper Back Support:

Press the back button to inflate the cushion highlighted in Fig.136, [Upper Back Support](#) to increase support at the mid-back region. This can help prevent the driver from sitting in a slouched, hunched, or hollow-back position.

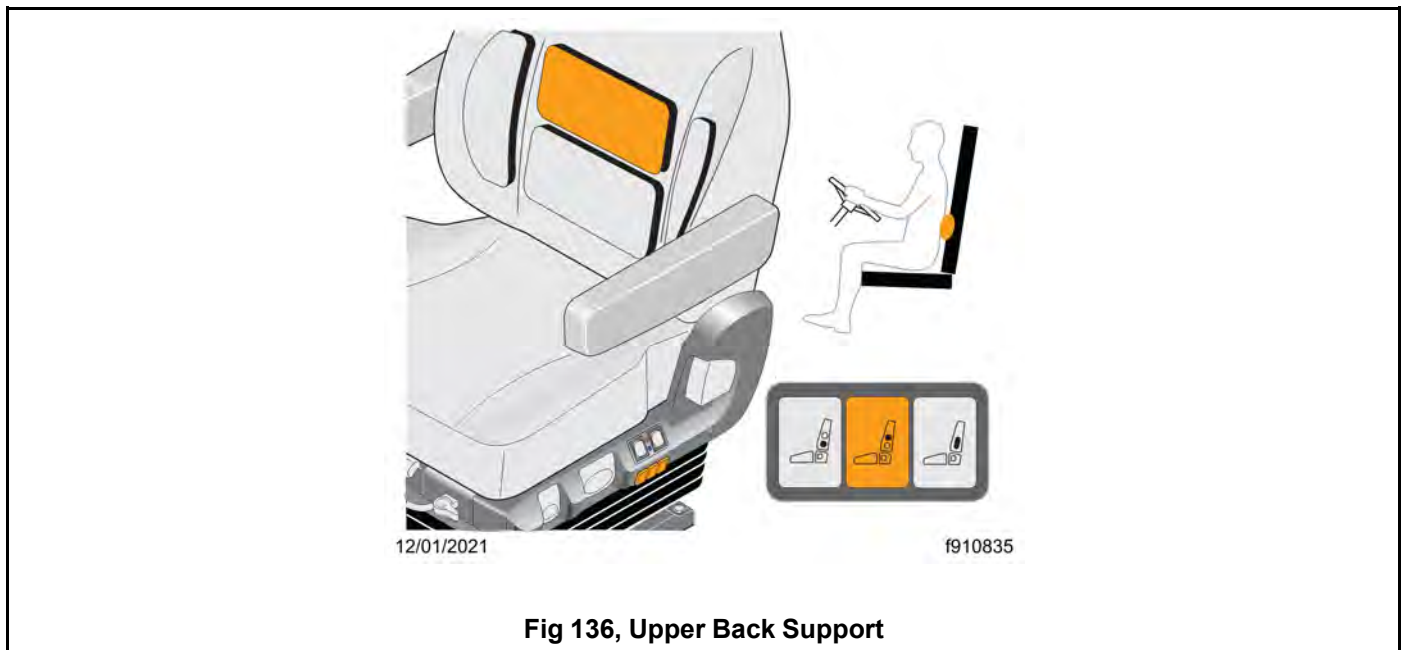

3. **Height Adjustment:** Pull or push the handle to adjust the seat height.

Adjust the seat so the driver's feet can move each pedal through a full range of motion without fully stretching out the driver's legs or using force.

4. **Damper Adjustment:** Move the lever down to increase damping on rough roads, or up to decrease damping on flat roads.

The damper protects the driver's spine by absorbing vertical vibrations and shocks. It should be adjusted down far enough that the driver's feet never lose contact with the pedals. In general, heavier drivers will not need to adjust the lever up.

5. **Forward/Back Isolator:** Rotate the isolator lever to the left to lock the isolator, or to the right to allow horizontal movement.

Damping horizontal shocks can be helpful with driving off-road or pulling a tank trailer.

6. **Seat Extension:** Pull the lever to move the seat cushion forwards or back. The cushion moves up to 2-3/8 inches (60 mm) in 3/8-inch (10-mm) increments. Releasing the lever locks the cushion in place.

Adjust the length of the seat cushion until there is space for three fingers between the cushion's front edge and the back the driver's knee. This helps to help improve circulation in the lower legs.

7. **Forward/Back Slide:** Pull the lever to unlock the seat and slide it forward or backward. Release the lever to lock the seat in position.

Adjust the seat so that reaching and pressing the pedals requires no effort and all dashboard controls are within easy reach.

8. **Seat Tilt:** Pull the lever and add or reduce weight on the front area of the seat cushion to move it into one of three positions. Release the lever to lock the seat into position.

The tilt of the seat, along with the tilt of the backrest and the contour of the seat cushion, affects the amount of pressure placed on the underside of the thighs and the back.

9. **Armrest Tilt:** To adjust the armrest angle, tilt the armrest to the highest position, then down to the lowest position, then to the desired position.

The armrest should be at an angle where the elbows lay lightly on it; this helps to relax the muscles in the shoulder and neck.

6.10 ISRI Basic High Back Seat

NOTE: The seat should only be adjusted when the vehicle is parked with the park brake on.

The seat is designed to hold a maximum driver's weight of 330 lbs.

The ISRI Basic seat controls are shown in Fig.137, [ISRI Basic High Back Seat](#).



12/02/2021

f910682e

- | | |
|--------------------------|-----------------------|
| 1. Backrest Tilt | 5. Seat Extension |
| 2. Low Back Support | 6. Forward/Back Slide |
| 3. Height Adjustment | 7. 7Seat Tilt Lever |
| 4. Forward/Back Isolator | |

Fig 137, ISRI Basic High Back Seat

1. **Backrest Tilt:** Pull the handle out completely and lean back or forwards to adjust the backrest tilt. Release the handle when the correct position is achieved. The backrest has a 52 degree range of movement.

When adjusted, the backrest inclination should allow the driver to reach the steering wheel with angled arms.

2. Lumbar (Lower) Back Support:

Press the forward button to inflate the cushion highlighted in Fig.138, [Lumbar Support](#) to increase support at the lower back. This moves the driver's spine into a double S shape and decreases pressure on the spine.



Fig 138, Lumbar Support

3. **Height Adjustment:** Pull or push the handle to adjust the seat height.
Adjust the seat so the driver's feet can move each pedal through its full range of motion without fully stretching out the driver's legs or using force.
4. **Forward/Back Isolator:** Rotate the isolator lever to the left to lock the isolator, or to the right to allow horizontal movement.
Damping horizontal shocks can be helpful with driving off-road or pulling a tank trailer.
5. **Seat Extension:** Pull the lever to move the seat cushion forwards or back. The cushion moves up to 2-3/8 inches (60 mm) in 3/8-inch (10-mm) increments. Releasing the lever locks the cushion in place.
Adjust the length of the seat cushion until there is space for three fingers between the cushion's front edge and the back the driver's knee. This helps to help improve circulation in the lower legs.
6. **Forward/Back Slide:** Pull the lever to unlock the seat and slide it forward or back. Release the lever to lock the seat in position.
Adjust the seat so that reaching and pressing the pedals requires no effort and all dashboard controls are within easy reach.
7. **Seat Tilt:** Pull the lever and add or reduce weight on the front area of the seat cushion to move it into one of three positions. Release the lever to lock the seat into position.
The tilt of the seat, along with the tilt of the backrest and the contour of the seat cushion, affects the amount of pressure placed on the underside of the thighs and the back.
8. **Armrest Tilt:** To adjust the armrest angle, tilt the armrest to the highest position, then down to the lowest position, then to the desired position.
The armrest should be at an angle where the elbows lay lightly on it; this helps to relax the muscles in the shoulder and neck.

6.11 Sears C-2 Plus Seat

Seat Slide Adjustment

NOTE: The seat should only be adjusted when the vehicle is parked with the park brake on.

Push the seat slide (forward/back adjustment) lever shown in Fig. 139, [Sears Low Profile Seat](#) all the way to the left and slide the seat forward or backward, as desired. Release the lever to lock the seat in the desired position.

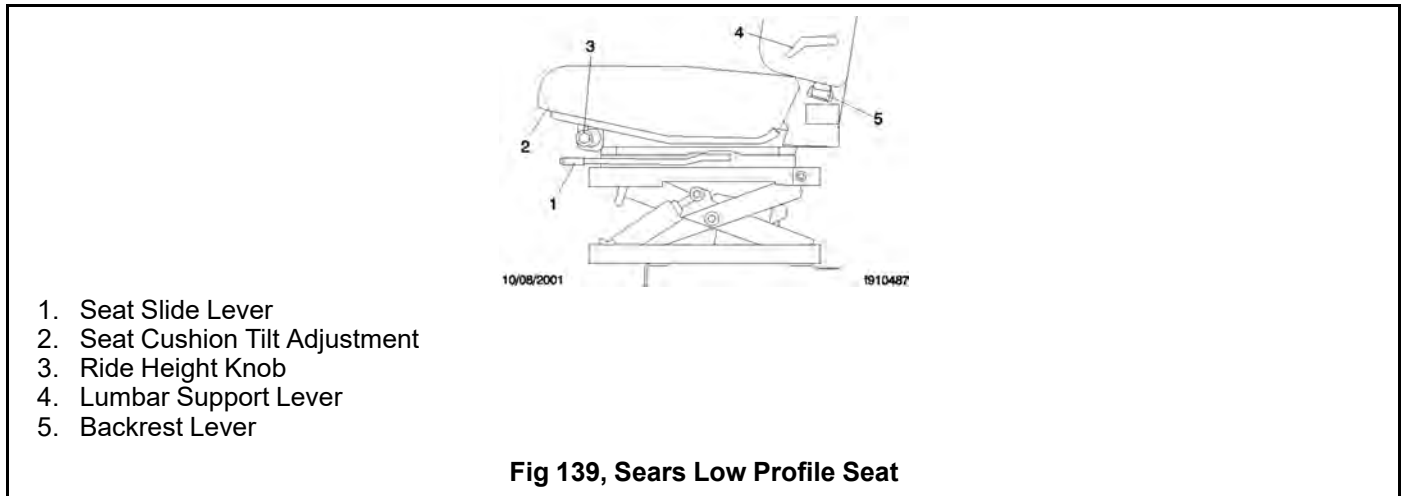

Isolator

To engage the isolator (if installed), move the seat slide and isolator lever, as shown in Fig. 140, [Sears Fleetmaster Seat \(with isolator\)](#), all the way to the right. To lock out the isolator, move the isolator lever to the center position.

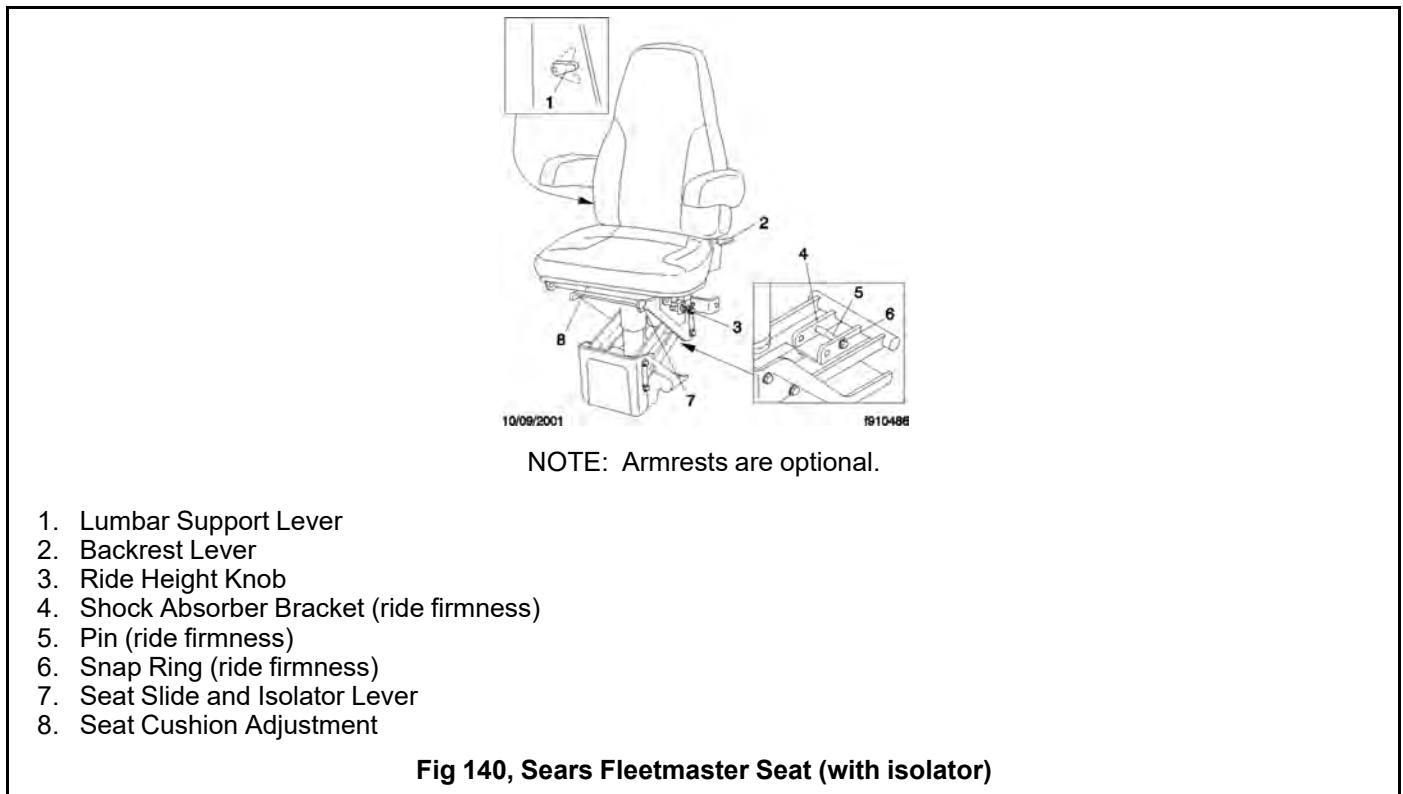

Lumbar Support

Move the three-position lumbar support lever upward to increase lumbar support (firmer). Move the lever downward to decrease lumbar support (less firm).

NOTE: This three-position lever (see inset) does not rotate a full 360 degrees.

For seats with air support, use the aft rocker switch on the control panel on the left-hand side of the seat, shown in Fig. 141, [Air Controls, Sears Seat](#). Press up to make the seat firmer; press down to make the seat less firm.

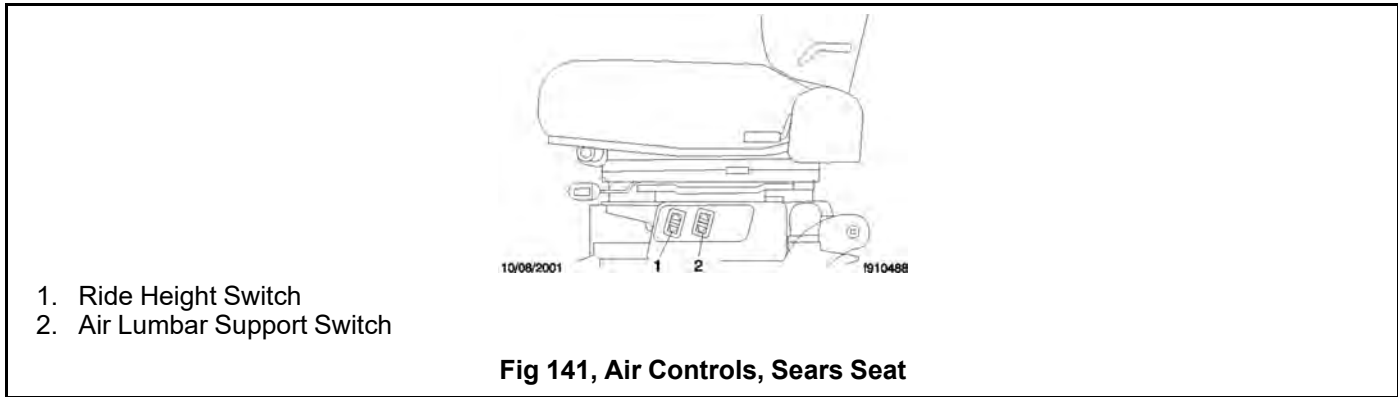

Seat Cushion Tilt

To raise the seat cushion, lift upward on the front of the seat cushion, and then push it rearwards. To lower the seat cushion, pull forward on the front of the seat cushion, and then push downwards.

Backrest Adjustment

To adjust the backrest, push downwards on the backrest lever just below the bottom of the backrest cushion. With the lever down, lean forward or backward to the desired position. Release the lever to lock the backrest in place.

Ride Height Adjustment

Push the ride height knob inwards to inflate the air cylinder, raising the height of the seat. Pull the ride height knob outwards to deflate the air cylinder, lowering the height of the seat.

For seats with air support, use the forward rocker switch on the control panel on the left-hand side of the seat as shown in 141, [Air Controls, Sears Seat](#). Press up to raise the seat; press down to lower the seat.

Ride Firmness Adjustment

For a softer ride, remove the snap ring and pin from the shock absorber bracket (see inset). Relocate the pin in the other set of holes in the bracket and secure it with the snap ring.

6.12 Bench Seats

A full width rear bench seat is optional on the 108SD Plus and 114SD Plus. See Fig.142, [Full Width Rear Bench Seat](#).

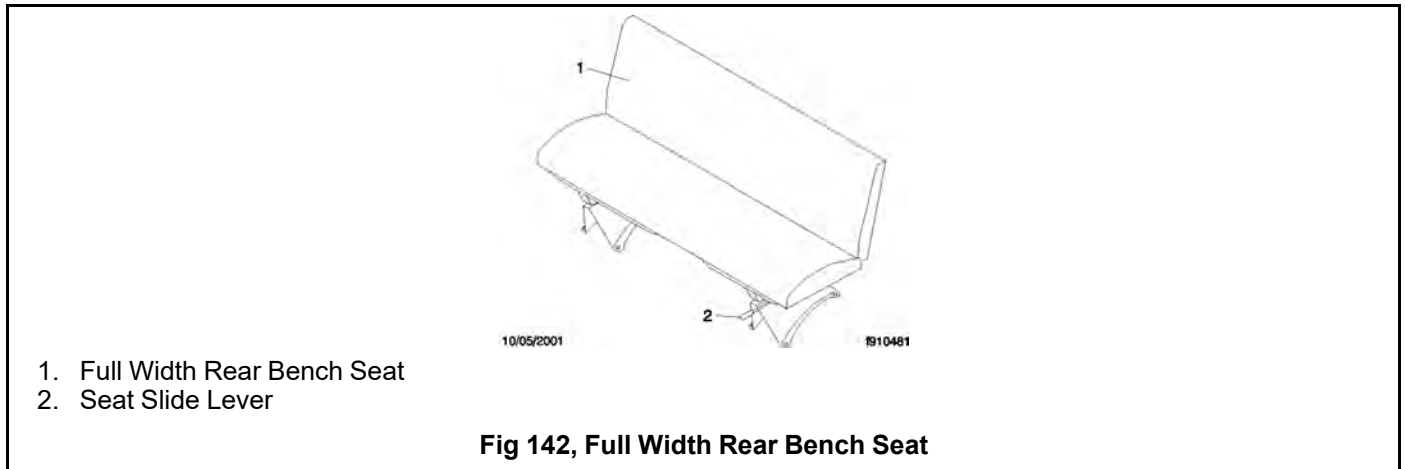

The full bench seat accommodates up to three passengers with lap belts and shoulder restraints. The full bench seat has a seat slide adjustment to adjust leg room. Release the seat slide lever and push backwards or forwards to move the seat along its track.

Also available is a two-person bench seat with a safe or tool box located under the seat. No adjustments are available on the two-person bench seat.

6.13 Seat Belts

6.13.01 Seat General Information

Seat belt assemblies are designed to secure persons in the vehicle to help reduce the chance of injury or the amount of injury resulting from accidents or sudden stops. For this reason, Daimler Truck North America LLC urges that the driver and *all* passengers, regardless of age or physical condition, use seat belts when riding in the vehicle.



WARNING:

Always use the vehicle's seat belt system when operating the vehicle. Failure to do so can result in severe personal injury or death.

Seat belt assemblies in Daimler Truck North America (DTNA) vehicles meet Federal Motor Vehicle Safety Standard 209, "Type 1" and "Type 2" requirements.

When transporting a child, always use a child restraint system or the vehicle seat belts as appropriate. To determine whether a child restraint system is required, review and comply with applicable state and local laws. Any child restraint used must comply with Federal Motor Vehicle Safety Standard 213, "Child Restraint Systems." When providing a child restraint system, always carefully read and follow all instructions pertaining to installation and usage for the child. Make certain the child remains in the restraint system at all times when the vehicle is in motion.

In addition to seat belt assemblies, tether belts are installed on suspension-type seats. Tether belts help secure the seat to the floor and are intended to restrain the seat and seat belt in case of an accident or sudden stop.

IMPORTANT: Seat belts have a finite life which may be much shorter than the life of the vehicle. Regular inspections and replacement as needed are the only assurance of adequate seat belt security over the life of the vehicle.

Seat Belt Inspection

**WARNING:**

Inspect and maintain seat belts. When any part of a seat belt system needs replacement, the entire seat belt must be replaced, both retractor and buckle side. Any time a vehicle is involved in an accident, and the seat belt system was in use, the entire vehicle seat belt system must be replaced before operating the vehicle. Do not attempt to modify the seat belt system; doing so could change the effectiveness of the system. Failure to replace worn or damaged seat belts, or making any modifications to the system, may result in personal injury or death.

Inspect the seat belts and tether belts (if so equipped).

1. Check the web for fraying, cuts, extreme dirt and dust, or for severe fading from exposure to sunlight, especially near the buckle latch plate and in the D-loop guide area.
2. Check operation of the buckle, latch, comfort clip or Sliding Komfort Latch (if equipped), web retractor, and upper seat belt mount on the door pillar. Check all visible components for wear or damage.
3. Check the seat belt and tether belt connection points and tighten any that are loose.

6.13.02 Seat Belt Operation

When engaged and used properly, the comfort clip, as shown in Fig.143, [Comfort Clip](#) and the Sliding Komfort Latch, as shown in Fig.144, [Sliding Komfort Latch](#) introduce a small amount of slack into the seat belt, resulting in a more comfortable ride.

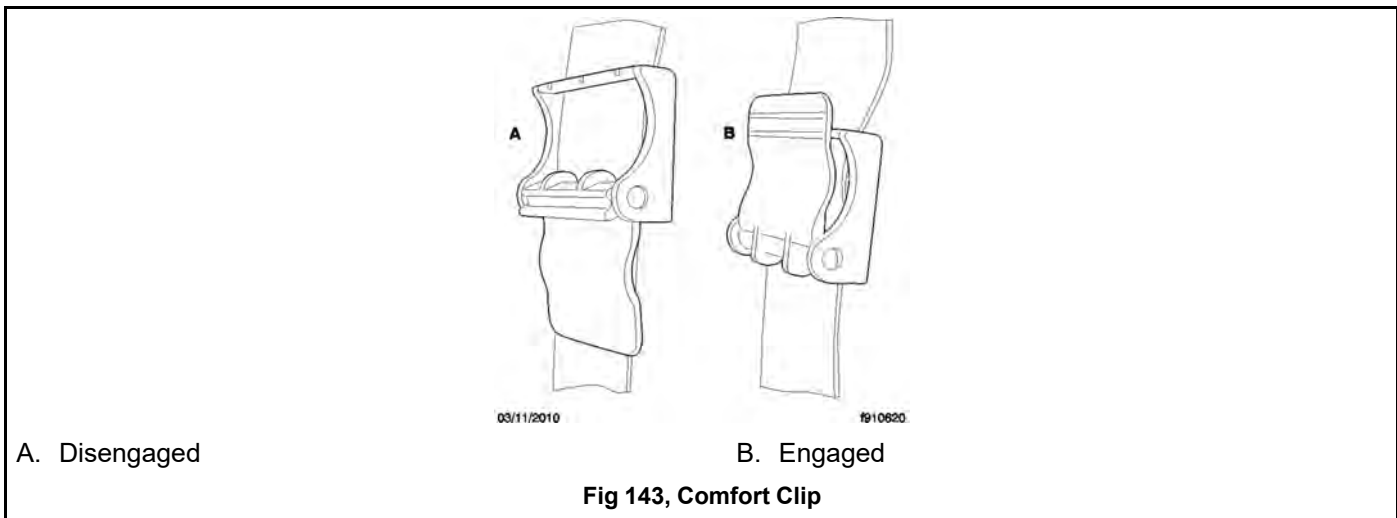



Fig 144, Sliding Komfort Latch

1. Slowly pull the latch end of the three-point seat belt out of the retractor and pull it across your lap (from outboard to inboard) far enough to engage the buckle. If the retractor locks too soon, allow the belt to retract slightly, then slowly pull it out again.
2. Fasten the three-point seat belt by pushing the latch into the buckle. Listen for an audible click. See Fig. 145, [Fastening the Three-Point Belt](#).

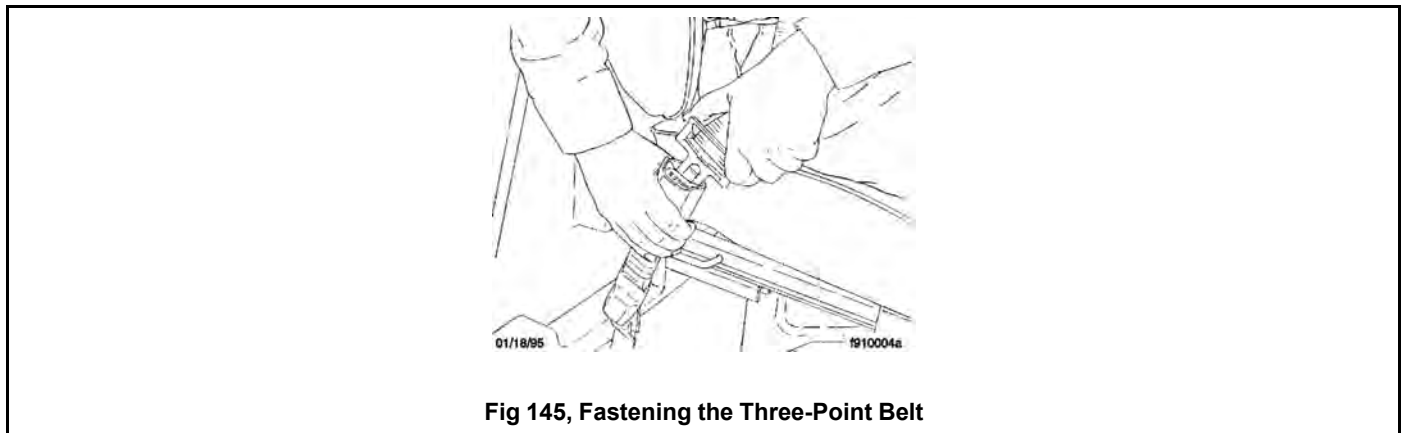

Fig 145, Fastening the Three-Point Belt

3. Tug on the seat belt to make sure it is securely fastened. If the buckle unlatches, repeat this step. If the problem continues, replace the three-point seat belt.
4. Snug the seat belt to your waist.
5. Position the shoulder strap diagonally across your chest with the adjustable D-loop bracket (if equipped). If desired, engage the comfort clip or Sliding Komfort Latch as follows.

If equipped with a comfort clip, pull on the shoulder strap to lessen the pressure of the strap on your shoulder and chest. Allow no more than 1 inch (2.5 cm) of slack between your chest and the shoulder harness. More slack can significantly reduce the seat belt effectiveness in an accident or a sudden stop. While holding the belt slack, press the comfort clip lever up, clamping the seat belt webbing as shown in Fig. 146, [Adjusting Shoulder Harness Clearance, Comfort Clip](#) and Fig. 147, [Locking the Comfort Clip](#).

146, [Adjusting Shoulder Harness Clearance, Comfort Clip](#) and Fig. 147, [Locking the Comfort Clip](#).

If equipped with a Sliding Komfort Latch, make sure that the shoulder strap is snug against your chest. Without loosening the shoulder strap, push the Sliding Komfort Latch switch to the "ON" position. See Fig. 144, [Sliding Komfort Latch](#). To activate the latch lean forward until you hear a click. This allows for approximately 1 inch (2.5 cm) of slack between your chest and the shoulder harness. Once engaged, the latch allows you to lean forward about 5 inches (13 cm) without having to reset the latch. Leaning forward more than 5 inches (13 cm) disengages the Sliding Komfort Latch, requiring it to be reset.

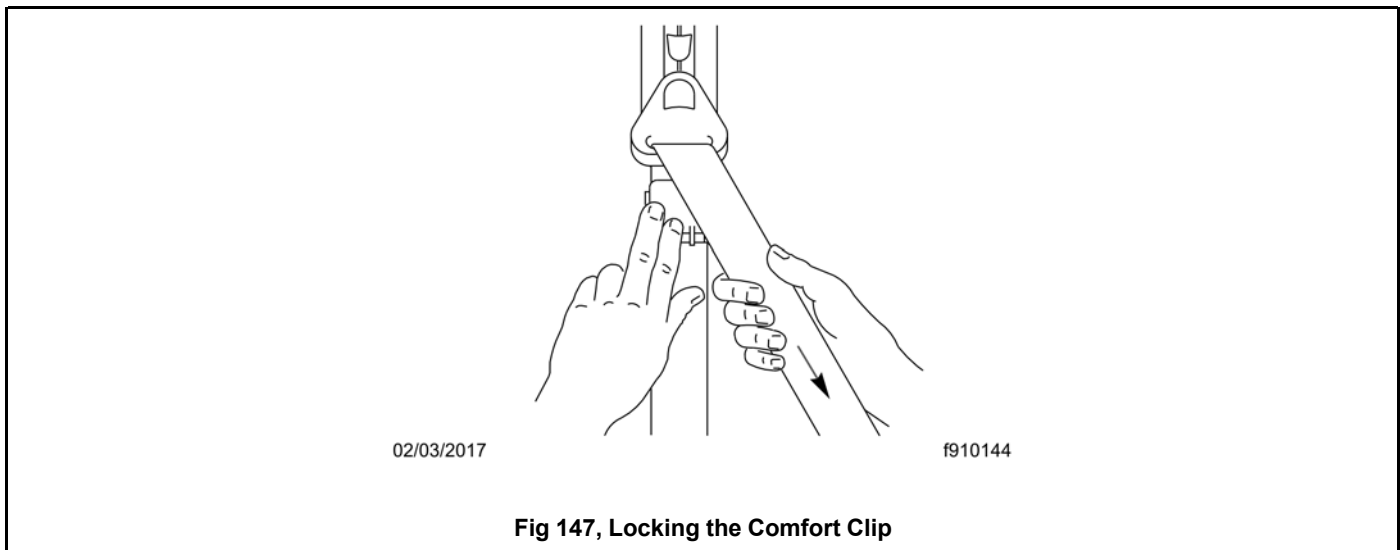
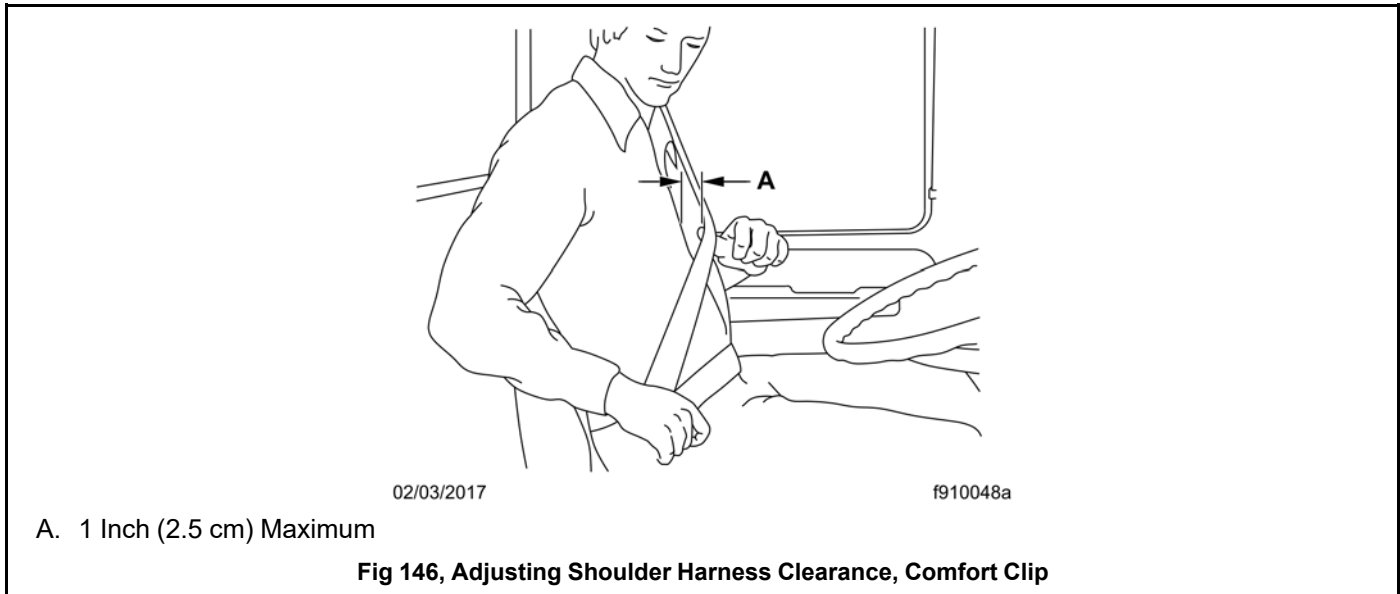

6. Unbuckle the three-point seat belt and release the comfort clip or the Sliding Komfort Latch as follows.

If equipped with a comfort clip, unbuckle the seat belt, then release the comfort clip by giving the shoulder belt a quick tug. If you lean forward against the shoulder belt, the comfort clip automatically releases, and needs to be reset.

If equipped with a Sliding Komfort Latch, unbuckle the seat belt, then tug on the shoulder belt to release the Sliding Komfort Latch, or press the Sliding Komfort latch to the "OFF" position, then unbuckle the seat belt.

6.14 RollTek Rollover Protection System

**WARNING:**

Always use the seat belts when operating the vehicle. Failure to do so can result in severe personal injury or death. Do not place infants and children in seats equipped with the RollTek system. The RollTek system is designed for adults only. Doing so could result in severe bodily injury or death. Keep all heavy objects in the cab secured. Do not place objects on the seat back or block the side-roll air bag. Objects that block the side-roll air bag may prevent proper inflation and could result in serious injury or death.

IMPORTANT: The RollTek system must be replaced after being activated. Damaged seat belts and tethers, or seat belts and tethers that were worn in an accident, must be replaced, and their anchoring points must be checked.

The RollTek system, when used with seat belts, provides additional protection to the driver and passenger (if equipped with a passenger-side system) in rollover accidents. See Fig. 148, [Rolltek Seat](#).

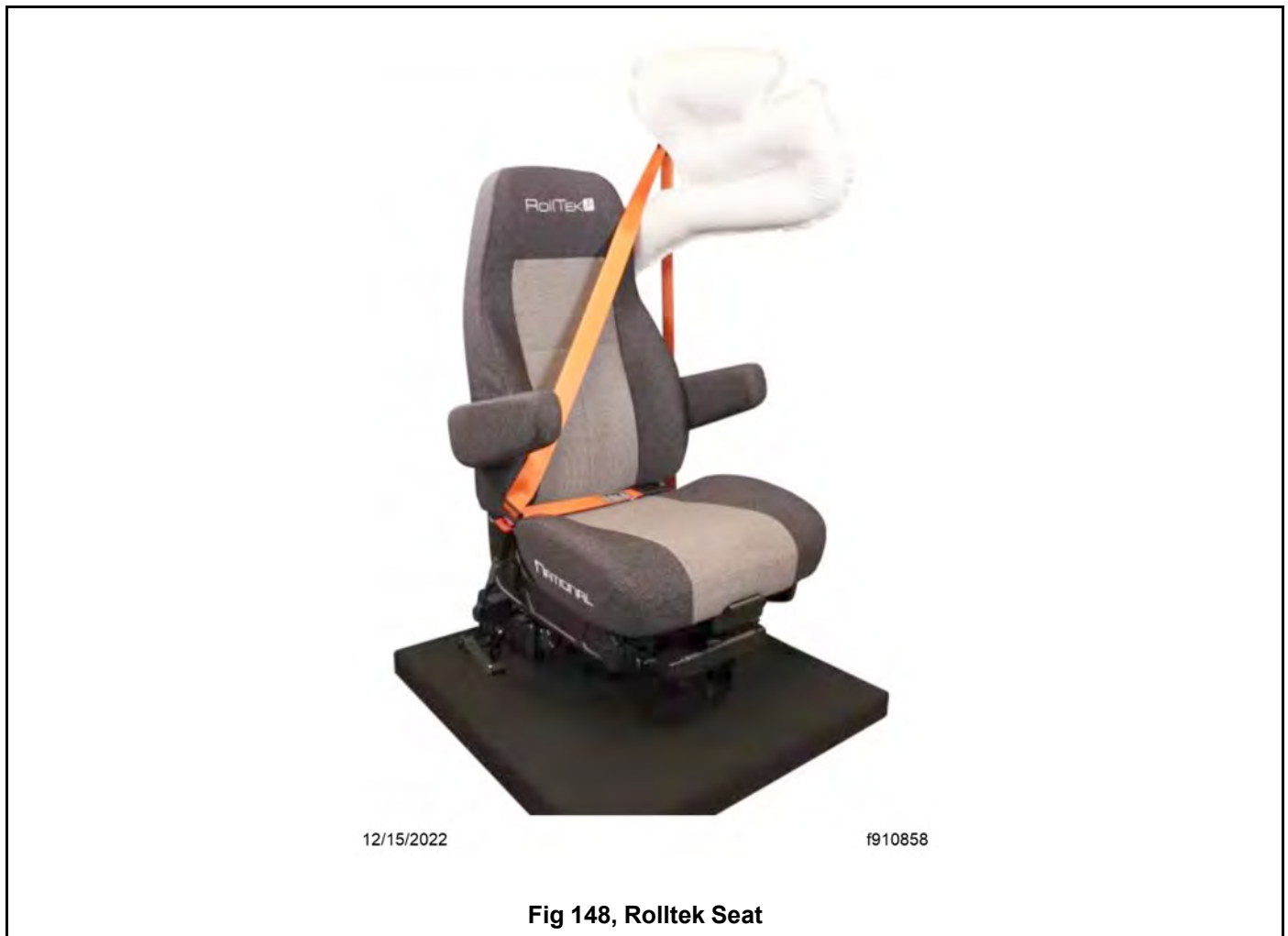

The RollTek system provides a significant increase in seat stability during a rollover. Vehicles equipped with RollTek rollover protection have a sensor mounted in the seat base that activates the side-roll air bag and seat pull-down device during a rollover. When the RollTek module senses a rollover, the module triggers gas cylinders mounted in the base of the seat. The gas cylinders activate the power cinches that then tighten the lap and shoulder belts against the occupant

of the seat and lower the seat suspension, moving the occupant down and away from the steering wheel and ceiling. The side-roll air bag deploys from the outboard side of the seat as the seat is pulled down to its lowest position.

The operational readiness of the RollTek system is indicated by the supplemental restraint system (SRS) indicator on the dash. The SRS indicator illuminates for several seconds when the ignition is turned on, and then it goes off. The indicator remains on if there is a problem with the air bag or RollTek system. The vehicle must be serviced if the SRS indicator does not illuminate when the ignition is turned on, or if the SRS indicator remains on.

**WARNING:**

Keep hands and tools away from the scissor points under the seats. The RollTek system contains components that use combustible chemicals. Do not cut, drill, braze, solder, weld, strike, or probe any part of the RollTek system. Keep all liquids and chemicals away from the RollTek components. Do not attempt to service or modify the RollTek system. Unintentional or improper deployment of the RollTek system could cause severe bodily injury or death. Contact an authorized Freightliner service facility for all service and maintenance.

The air bag module may contain perchlorate material; for information, see www.dtsc.ca.gov/hazardouswaste/perchlorate. Special handling may apply; follow appropriate rules and regulations when disposing of materials.

For all service and maintenance, contact an authorized Freightliner service facility.

7.01 Detroit Assurance Collision Mitigation System (CMS).....	152
7.01.01 General Information	152
7.01.02 Driver's Display.....	152
7.02 Detroit Assurance Vehicle Cameras.....	153
7.02.01 Multipurpose Camera 2 (MPC2).....	153
7.02.02 Driver Facing Camera	154
7.02.03 Rain Light Sensor	154
7.02.04 Bendix Forward Facing Camera.....	154
7.03 Detroit Assurance Adaptive Cruise Control (ACC).....	155
7.03.01 Adaptive Cruise Control Safety Information.....	155
7.03.02 Adaptive Cruise Control Overview	156
7.04 Detroit Assurance Tailgate Warning	159
7.05 Detroit Assurance Active Brake Assist 5 (ABA5).....	159
7.05.01 Active Brake Assist 5 Overview.....	159
7.05.02 Active Brake Assist 5 Safety Information.....	160
7.05.03 Activating and Deactivating Active Brake Assist 5.....	160
7.05.04 Active Brake Assist 5 Collision Warning and Emergency Braking.....	161
7.06 Limitations of Detroit Assurance ABA5 and ACC.....	163
7.07 Detroit Assurance Side Guard Assist (SGA) and Active Side Guard Assist (ASGA)	167
7.07.01 General Information	167
7.07.02 Safety Information.....	169
7.07.03 Sensor Monitoring Range of SGA.....	170
7.07.04 SGA Indicator Lamps	171
7.07.05 Activating and Deactivating Side Guard Assist	174
7.07.06 Driving Scenarios and SGA Warnings.....	180
7.08 Detroit Assurance Traffic Sign Display	183
7.08.01 General Information	183
7.08.02 Safety Information.....	183
7.08.03 Traffic Sign Display Functionality.....	183
7.08.04 Activating or Deactivating	185

7. Detroit Assurance 5.0

7.01 Detroit Assurance Collision Mitigation System (CMS)

7.01.01 General Information

The Detroit Assurance collision mitigation system (CMS) is a safety system that uses a radar mounted on the front frame crossmember, shown in Fig. 149, [Forward Radar Location](#), and a windshield-mounted multipurpose camera to communicate information to active features that can control the truck.

The system can track vehicles up to 820 ft (250 m) ahead, and if necessary sounds a warning and applies the brakes.

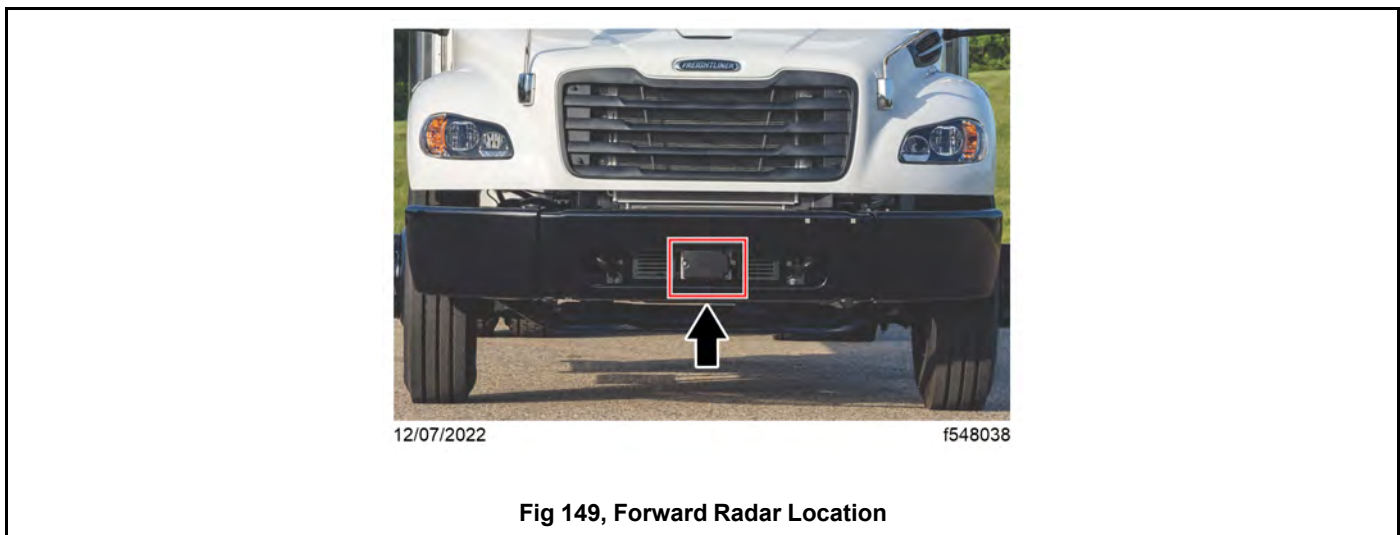

IMPORTANT: Do not mount any attachments in front of the radar distance sensor. Do not paint or affix items over the distance sensor cover. Keep the cover free of mud, ice, and snow. Attachments mounted in front of the distance sensor, such as a crash guard, and objects on the sensor cover can impair the sensor's operation.

7.01.02 Driver's Display

The M2 Plus is equipped with an instrument cluster unit common (ICUC). The driver's display, on the ICUC, presents the status and warnings from the different features that make up the Detroit Assurance safety system.

The standard core features of Detroit Assurance on the Freightliner M2 Plus 106 include active brake assist 5 (ABA5) and lane departure warning (LDW) with a fifteen minute timeout switch.

The standard core features of Detroit Assurance on the Freightliner M2 Plus 112 include active brake assist 5 (ABA5), adaptive cruise control (ACC) with fixed headway, tailgate warning, and lane departure warning (LDW) with a fifteen minute timeout switch.

Optional safety features include traffic sign display, active speed intervention, and either side guard assist or active side guard assist (SGA).

The right-hand steering wheel switch pod, shown in Fig. 150, [Right-Hand Steering Wheel Switch Pod, ICUC](#), contains adaptive cruise control (ACC) controls and access to Detroit Assurance settings via the 'quick access system settings' button.

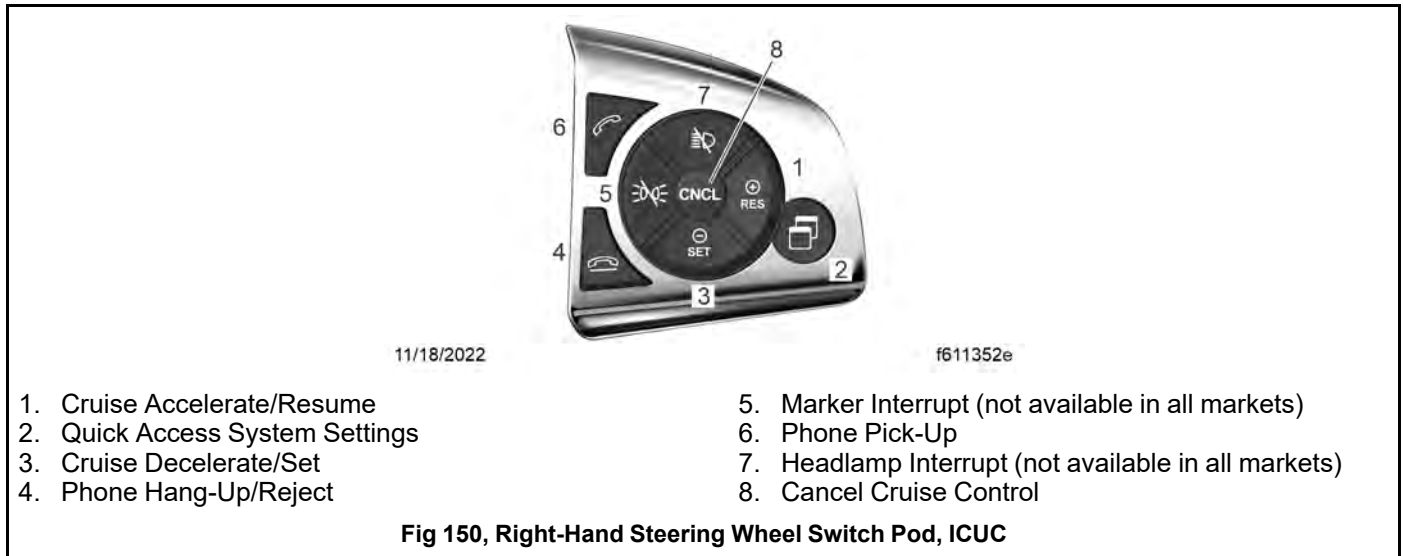

7.02 Detroit Assurance Vehicle Cameras

7.02.01 Multipurpose Camera 2 (MPC2)

IMPORTANT: The windshield must be clean, unobstructed, and without damage for the proper operation of the multipurpose camera and rain/light sensor.

The camera bracket that comes with Detroit Assurance 5.0 can hold a driver facing camera (DFC), multipurpose camera 2 (MPC2), and rain/light sensor (RLS). The unit is mounted against the windshield. See Fig. 151, [MPC2 Component Locations](#).

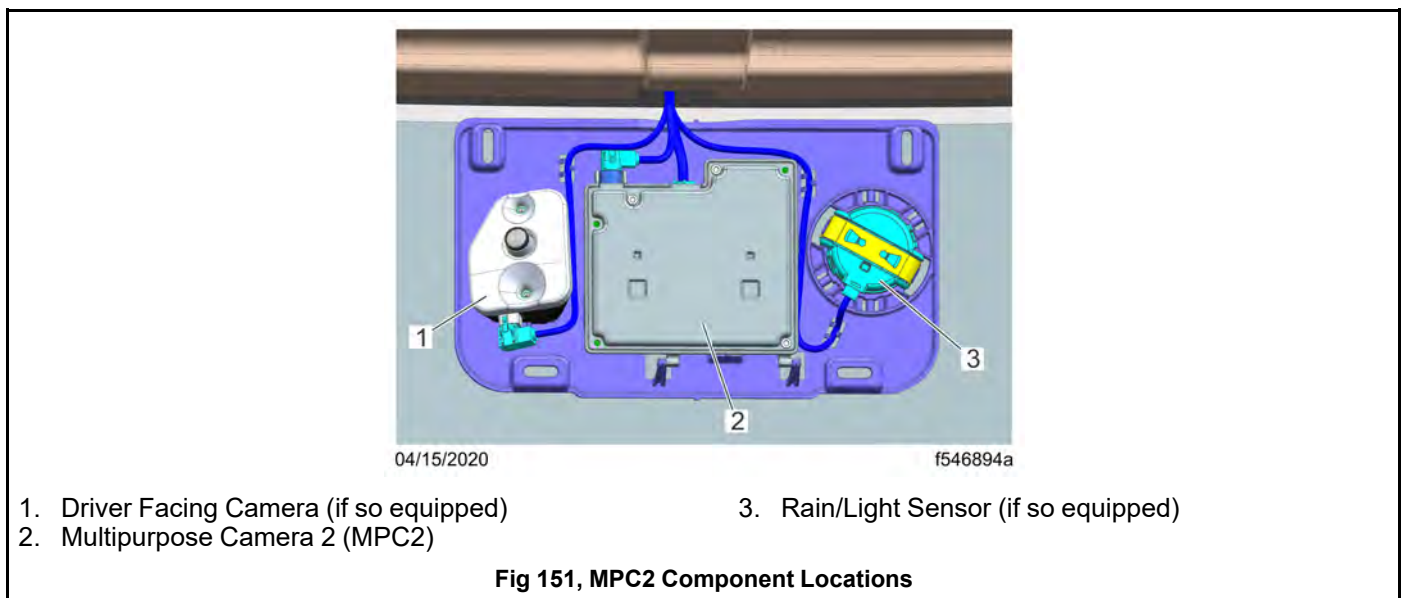

The MPC2 works with the radar system to support multiple Detroit Assurance features. It is important for the driver to keep the windshield clean and unobstructed in order for the MPC2 to operate properly.

7.02.02 Driver Facing Camera

IMPORTANT: The windshield must be clean, unobstructed, and without damage for the proper operation of the multi-purpose camera and rain/light sensor.

The driver facing camera, if equipped, records the interior view in the case of a safety critical event.

7.02.03 Rain Light Sensor

IMPORTANT: The windshield must be clean, unobstructed, and without damage for the proper operation of the multi-purpose camera and rain/light sensor.

This rain/light sensor, if equipped, detects rain, snow, or other precipitation on the windshield and can determine the amount of ambient light.

If the windshield wipers are set to intermittent operation, they automatically start clearing the windshield when the RLS detects precipitation. For additional windshield wiper and headlight information, see [5.01 Ignition Switch and Key](#).

If the headlight switch is set to the automatic or 'A' position, the low beam headlights and vehicle exterior lights turn on when the RLS registers a low level of ambient light. This could happen due to sunset, fog, smoke, or any other event that decreases light levels.

7.02.04 Bendix Forward Facing Camera

IMPORTANT: In order for the forward facing camera to operate properly, the windshield area in front of the camera must be clean, unobstructed, and not be damaged in any way.

An optional Bendix forward facing 5G camera that works in tandem with the Detroit Assurance MPC2 camera is an available option on the vehicle. If equipped, the Bendix camera appears as shown in Fig. 152, [MPC2 and Bendix Camera Brackets](#).

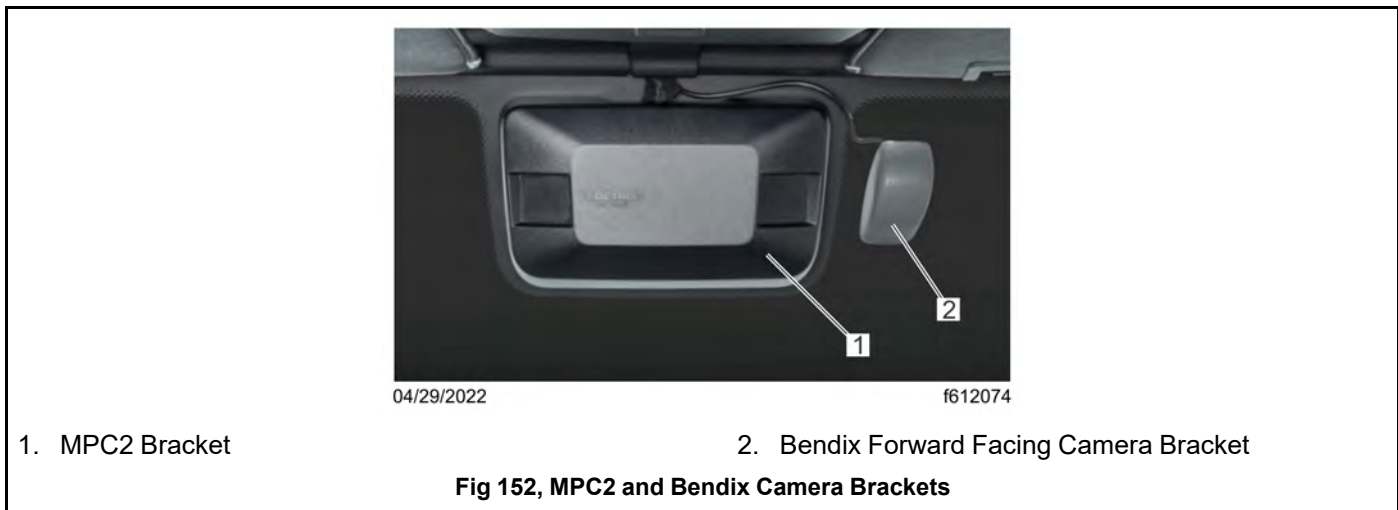

The Bendix camera records in color and can capture high-quality video in low light conditions. For more information about the Bendix camera, see the SafetyDirect by Bendix section in this chapter.

7.03 Detroit Assurance Adaptive Cruise Control (ACC)

7.03.01 Adaptive Cruise Control Safety Information

**WARNING:**

The Detroit Assurance Collision Mitigation System is intended solely as an aid for an alert and conscientious professional driver. It is not intended to be relied upon to operate a vehicle. Use the system in conjunction with rearview mirrors and other instruments to safely operate the vehicle.

The Detroit Assurance Collision Mitigation System is not a substitute for safe, normal driving procedures, nor will it compensate for any driver impairment such as drugs, alcohol, fatigue, distraction or inattention.

Operate a vehicle equipped with Detroit Assurance Collision Mitigation System as if the vehicle were not equipped with a collision mitigation system.

Failure to drive safely and use the system properly could result in personal injury and/or death and severe property damage.

NOTE: In vehicles equipped with a DT12 transmission, this feature is called Adaptive Cruise Control to 0 mph. In instances where the feature capabilities are different, this will be called out. Otherwise, the feature will be called Adaptive Cruise Control (ACC).

ACC may not detect vehicles driving in a different lane or narrow vehicles, like motorcycles, driving in front.

In particular, stay aware in the following situations:

- when cornering, entering, and exiting bends;
- when driving winding stretches of road;
- when overtaking;
- when there are vehicles driving in a different lane;
- when vehicles are changing lanes;
- when vehicles are exiting the road;
- when there are obstacles and stationary vehicles.

ACC does not compensate for inattentive driving, weather, or traffic conditions. ACC is only an aid. The driver is responsible for maintaining a safe distance from the vehicle in front, maintaining a safe vehicle speed, braking, and remaining in a lane.

If ACC does not detect a vehicle driving in front, the system will accelerate to the set speed.

7.03.02 Adaptive Cruise Control Overview



WARNING:

The Detroit Assurance Collision Mitigation System is intended solely as an aid for an alert and conscientious professional driver. It is not intended to be relied upon to operate a vehicle. Use the system in conjunction with rearview mirrors and other instruments to safely operate the vehicle.

The Detroit Assurance Collision Mitigation System is not a substitute for safe, normal driving procedures, nor will it compensate for any driver impairment such as drugs, alcohol, fatigue, distraction or inattention.

Operate a vehicle equipped with Detroit Assurance Collision Mitigation System as if the vehicle were not equipped with a collision mitigation system.

Failure to drive safely and use the system properly could result in personal injury and/or death and severe property damage.

See Table 20, [Steering Wheel Controls](#) and Fig. 153, [Steering-Wheel-Mounted Right-Hand Switch Pod, ICUC](#) for a description of cruise control steering wheel switches.

Description	Function
-/SET	Sets the cruise speed while the vehicle is traveling at the desired speed. Pressing and holding decreases the set cruise speed.
+ /RES	Resumes the set speed. Pressing and holding increases the set cruise speed.
CNCL	Deactivates cruise control, but retains the set speed in memory.

Table 18, Steering Wheel Controls

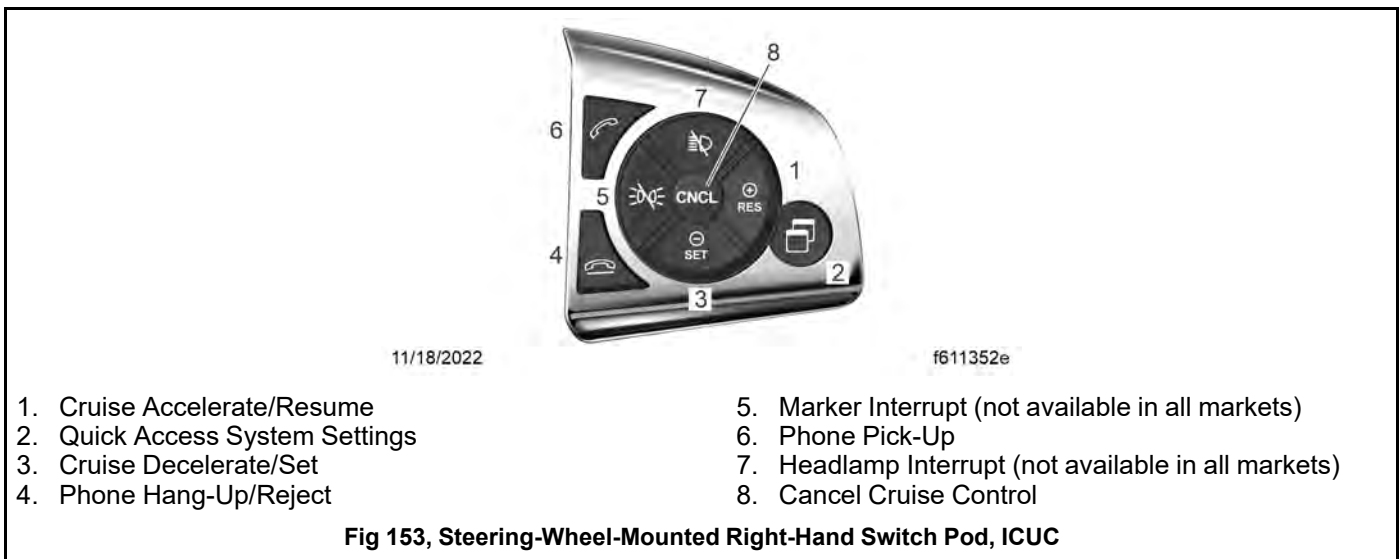

Fig 153, Steering-Wheel-Mounted Right-Hand Switch Pod, ICUC

When a vehicle is detected in front, the driver display shows a generic image of the detected vehicle with the speed of and the distance to the detected vehicle at the top. An example of how this looks on the ICUC screen is shown in Fig. 154, [Adaptive Cruise Control \(ACC\) Screen - ICUC](#).



Fig 154, Adaptive Cruise Control (ACC) Screen - ICUC

Adaptive Cruise Control Functions and Activation Conditions

Adaptive cruise control (ACC) controls the speed of the equipped vehicle to maintain a preset distance from a vehicle detected in front. It remains the driver's responsibility to ensure an appropriate distance is maintained.

If ACC detects a vehicle in front driving at a slower speed, the engine is defueled, the engine brakes are activated, and the service brakes are applied, slowing the vehicle to maintain the set following distance. The standard factory set following distance is 3.6 seconds; for vehicles configured with adjustable headway, this can be adjusted under the 'Cruise Control' menu under 'Vehicle Settings.'

ACC allows the vehicle to operate in cruise all the way down to 0 mph (0km/h); as traffic in front of the vehicle slows and eventually stops, the vehicle will adjust with the traffic all the way to 0 mph (0km/h).

If the vehicle ahead is stopped for two seconds or less, ACC will resume when the vehicle ahead moves. If the vehicle ahead is stopped for more than two seconds, the driver after carefully checking surrounding traffic will need to press the resume button or tap the accelerator pedal to resume moving forward.

The ACC will also slow the vehicle if it exceeds the set speed (on a downhill grade, for example).

If there is no vehicle in front, ACC operates in the same way as cruise control when the vehicle is traveling above 10 mph (15 km/h).

IMPORTANT: Nothing should be put between the driver and the seat, such as a heating pad, massage pad, or similar items. Doing so may keep the seat occupancy sensor from functioning correctly. ACC to 0 mph verifies seat occupancy before resuming forward motion after slowing down to 0 mph.

ACC cannot be activated, or is automatically deactivated, if:

- the driver is not in their seat to activate the seat occupancy sensor;
- the vehicle is traveling slower than 10 mph (15 km/h);
- the transmission is in neutral for more than 5 seconds;
- reverse gear is selected;

- the Anti-Lock Braking System (ABS) is deactivated;
- there is a malfunction in the brake system or the electronic management system; or
- the distance sensor initialization is not yet complete.

Activating Adaptive Cruise Control and Setting the Speed

Activate ACC by setting the cruise speed, using the controls on the steering wheel. See Table 20, [Steering Wheel Controls](#).

When driving at the desired speed, press the /SET switch to activate ACC and store the set speed.

If cruise control is deactivated, the stored speed can be activated again by pressing the +/RES switch on the steering wheel switch pod. When activated, the driver display shows the adaptive cruise control telltale and the set speed.

If the brake pedal is pressed, ACC is deactivated automatically.

If ACC becomes unavailable, a message appears on the driver display screen. If the vehicle is programmed to allow for standard cruise control, the message displayed allows the driver to use standard cruise control. See Fig. 155, [Adaptive Cruise Control \(ACC\) Unavailable - ICUC](#).



Fig 155, Adaptive Cruise Control (ACC) Unavailable - ICUC

Increasing or Reducing Adaptive Cruise Control Speed

The ACC speed setting can only be set when driving.

Press the /SET switch on the steering wheel switch pod to set the cruise speed when the vehicle is traveling at the desired speed. To decrease the set cruise speed, press and hold /SET.

Setting the Adaptive Cruise Control Distance to the Vehicle in Front

If equipped, the ACC ICUC menu under 'Settings' > 'Safety Systems Settings' > 'More Information' > 'Adaptive Cruise Control' can be used to set the overspeed and underspeed limits and the following distance to the vehicle in front.

If equipped, the ACC ICC5 following distance can be adjusted under 'Settings' > 'Driving Assistance' > 'Adaptive Cruise Control.'

IMPORTANT: Make sure that the minimum distance required by law is maintained.

Overtaking When Using Adaptive Cruise Control

NOTE: It is possible to exceed the set speed when overtaking.

The set speed of ACC can be exceeded using the accelerator pedal. When the accelerator pedal is released, the ACC set speed will be resumed.

Deactivating Adaptive Cruise Control

To deactivate ACC, press the CNCL switch on the steering wheel switch pod or press the brake pedal.

NOTE: The set speed remains stored when ACC is deactivated.

7.04 Detroit Assurance Tailgate Warning

The tailgate warning provides alerts when the vehicle in front is being followed too closely.

The system gives warning when:

- ACC is not active;
- the vehicle is moving faster than 20 mph (32 km/h);
- the driver follows a vehicle for longer than 10 seconds at a distance that will be traversed in less than 2.6 seconds.

The system will also give warnings when ACC is active, if:

- the driver is overriding the distance control by pressing on the accelerator pedal;
- the vehicle is moving faster than 20 mph (32 km/h);
- the driver follows a vehicle for longer than 10 seconds at a distance that will be traversed in less than 2.6 seconds.

The system will continue to give warning every 20 seconds if the gap between the vehicles does not increase.

The system will **not** give warning when:

- the vehicle is moving slower than 20 mph (32 km/h);
- another vehicle cuts in front;
- the vehicle in front is moving away;
- ACC distance control is active.

7.05 Detroit Assurance Active Brake Assist 5 (ABA5)

7.05.01 Active Brake Assist 5 Overview

IMPORTANT: The windshield must be clean, unobstructed, and without damage for proper operation of the multipurpose camera. No objects or attachments should be mounted in front of the forward radar and the radar covering should be free of paint, stickers, mud, ice, or snow.

ABA is active when the vehicle is on.

ABA uses fused camera and radar signals for improved object recognition, enabling it, in some cases, to recognize potential hazardous situations faster than a driver. If the camera cannot positively identify an object, radar signals alone are used. If the camera becomes unplugged or otherwise disabled, ABA is disabled.

ABA tracks both moving and stationary objects in the vehicle's path and, if necessary, engages in a cascade of defensive actions in reaction to those objects through:

1. visual and auditory warnings;
2. then partial braking;
3. then full or emergency braking.

In addition to moving and braking vehicles, ABA has the capacity to recognize and engage in emergency braking for moving pedestrians, parked vehicles, and stopped traffic.

However, the system may not detect pedestrians or objects in every situation. ABA is not a substitute for cautious driving.

7.05.02 Active Brake Assist 5 Safety Information

**WARNING:**

Active Brake Assist (ABA) is intended only as an aid for a conscientious and alert driver. The driver is responsible for keeping a safe distance from the vehicle in front, for the vehicle speed, braking in a sufficient amount of time, and remaining in the lane.

ABA does not take road and weather conditions into account, nor the prevailing traffic situation. The driver should always adapt their driving to suit road and weather conditions.

The Detroit Assurance Collision Mitigation System is not designed to warn about all possible road hazards. Specifically, it is not programmed to react to animals, oncoming vehicles, or cross traffic, but it may do so.

Operate a vehicle equipped with Detroit Assurance Collision Mitigation System as if the vehicle were not equipped with a collision mitigation system.

Failure to drive safely and use the system properly could result in personal injury and/or death and severe property damage.

A vehicle equipped with ABA may:

- react more quickly than a driver to an object in the vehicle's path of travel;
- perform emergency braking;
- react to moving people with a warning and emergency braking.

ABA can minimize the risk of a front-end collision with a moving or stationary vehicle and pedestrians. If ABA detects the risk of a front-end collision, it issues an audible and visual warning. If the risk persists, ABA automatically initiates partial braking of the vehicle. If the driver does not react to the warnings and partial brake application, ABA automatically initiates a full emergency brake application.

ABA is not designed to detect and react to vehicles driving in a different lane.

ABA may not react to narrow vehicles, like motorcycles, driving in front of the vehicle.

A driver should always be aware of possible hazards and be prepared to engage the service brakes if the ABA system warns of a possible pending collision.

ABA does not automatically adapt to road and traffic conditions. If ABA issues no visual and/or acoustic warning in a critical situation:

- it is suppressed;
- it has failed;
- it has not recognized the danger of the situation.

ABA may also issue warnings where no risk exists. An alert and conscientious driver should be able to easily validate an ABA warning, and, if necessary, override a false-positive ABA braking event.

7.05.03 Activating and Deactivating Active Brake Assist 5

To override the ABA warning and braking sequence, press the accelerator pedal past the pressure point to engage kickdown.

If there is a system error, the ABA unavailable telltale, as shown in Fig.156, [ABA Unavailable Warning](#), illuminates on the driver display screen and a caution window, as shown in Fig.157, [ABA Unavailable Alert - ICUC](#), is shown on the driver display.

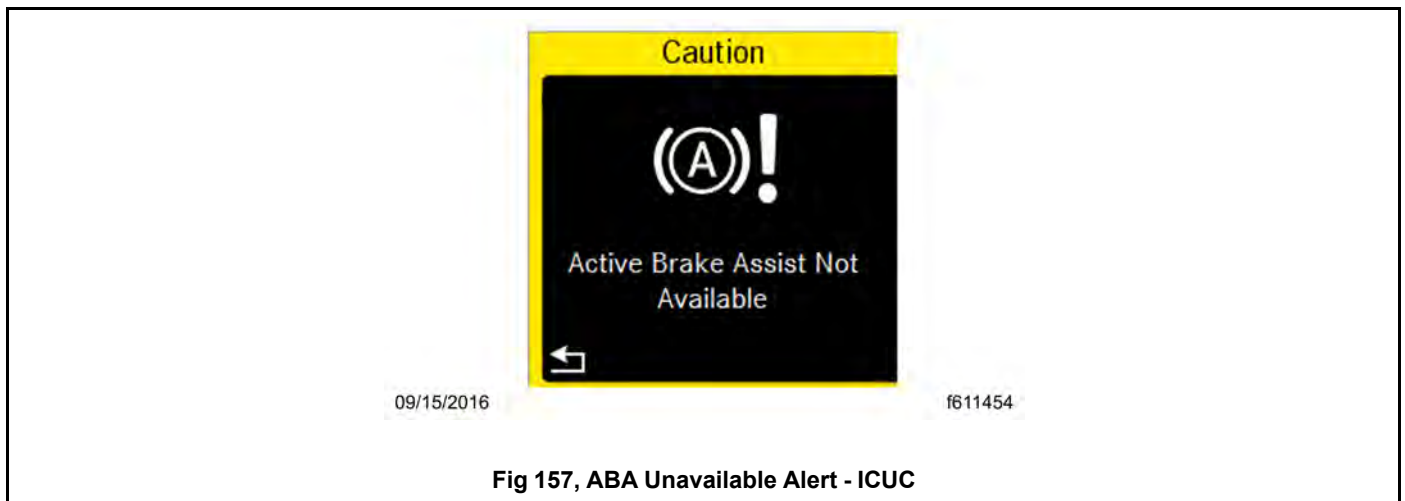

7.05.04 Active Brake Assist 5 Collision Warning and Emergency Braking

NOTE: A driver can override ABA if, during an ABA braking event, the driver presses the accelerator pedal beyond the pressure point to engage kickdown.

If there is a collision risk, ABA engages in the following cascade of warnings:

1. **Issues Warnings:** the radio and/or hands free system is muted, the vehicle issues a warning beeping, and an ABA collision warning window, shown in Fig.158, [First Visual ABA Warning - ICUC](#), appears on the driver display.

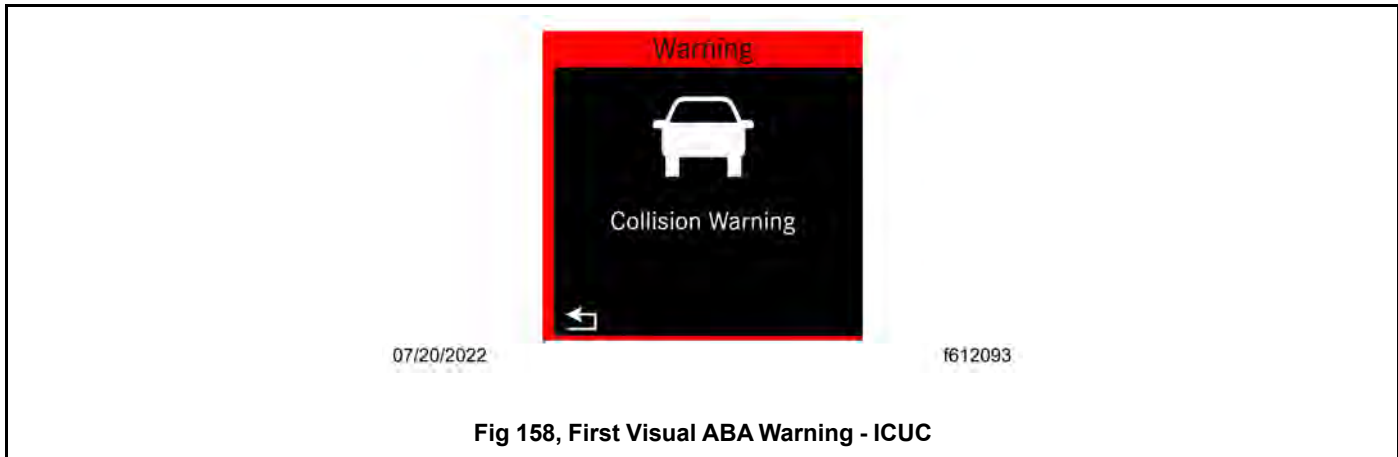

2. **Engages in Partial Braking:** ABA brakes the vehicle with around 50 percent of the vehicle's maximum braking power.

The radio and/or hands free system stays muted, the warning beeping continues, and the ABA collision warning, shown in Fig. 158, [First Visual ABA Warning - ICUC](#), continues to appear or, if previously dismissed, reappears on the driver display.

3. **Engages in Emergency Braking:** If a driver does not react to the collision warnings or partial brake application, ABA brakes the vehicle with 100 percent of the vehicle's maximum braking power.

The radio and/or hands free system stays muted, the warning beeping shifts to a continuous tone, and the emergency braking warning, shown in Fig. 159, [Second Visual ABA Warning - ICUC](#) appears on the driver display.

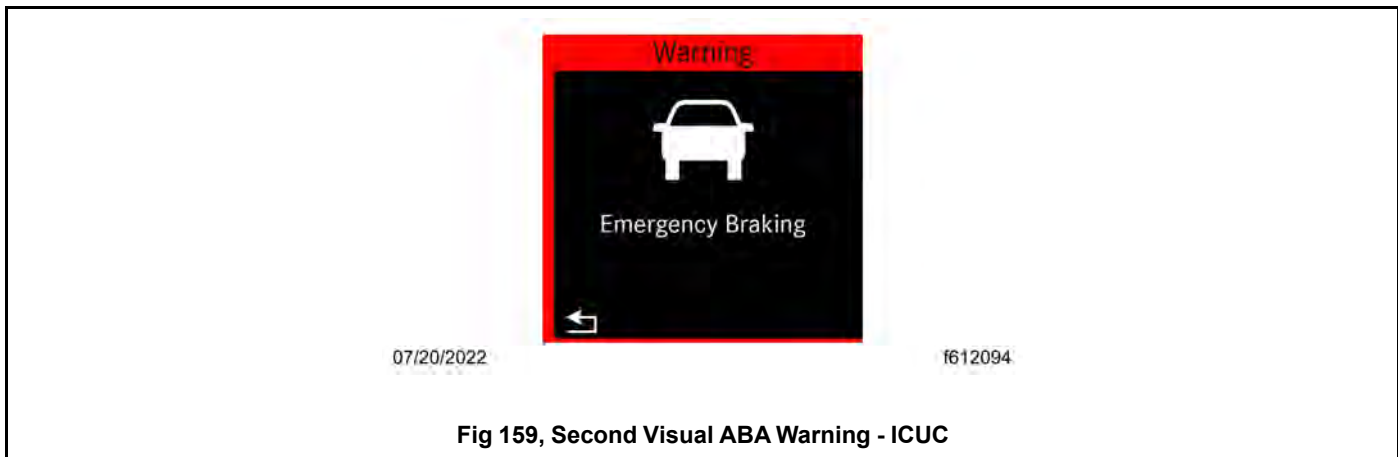

4. **Brakes Release:** The radio and/or hands free system is taken off mute, the warning tone ceases, and the notice shown in Fig. 160, [Third Visual Warning in ABA Cascade](#) appears on the driver display.

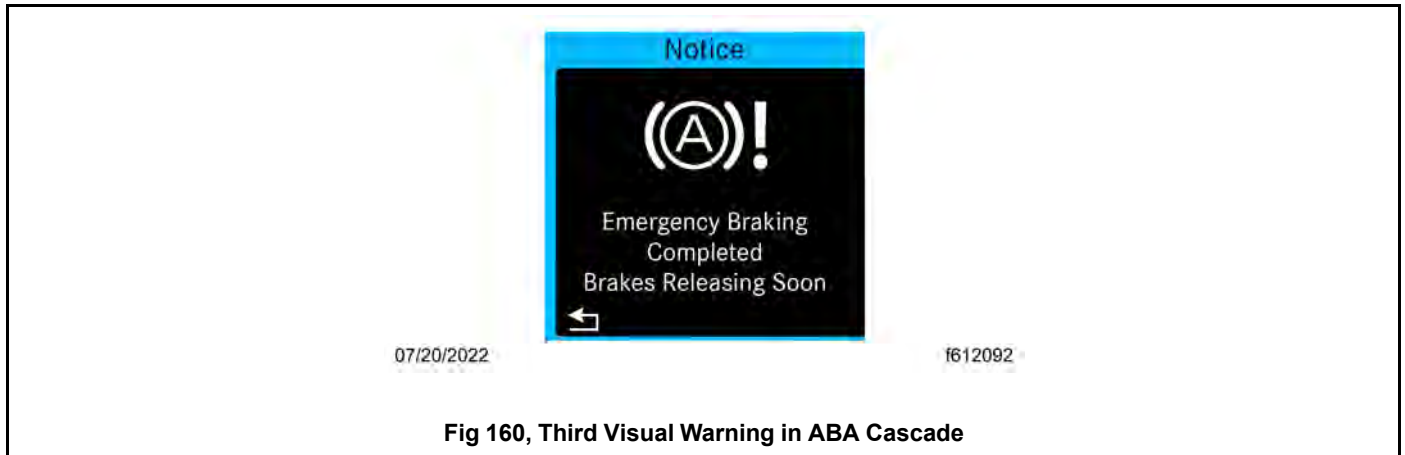

Fig 160, Third Visual Warning in ABA Cascade

After retaking control, the driver should take the first opportunity to safely move the vehicle from traffic. Before continuing, the driver should confirm that the vehicle is in good operating condition and that the load is still properly secured.



CAUTION:

After an emergency braking maneuver has been performed, retake control of the vehicle and, if necessary, move the vehicle from the area of danger.

Take the first opportunity to safely move the vehicle from traffic to confirm the load is still properly secured and that the vehicle is still in good operating order. Failure to do so may result in personal injury and product or property damage

Always apply the parking brake prior to exiting the vehicle.

7.06 Limitations of Detroit Assurance ABA5 and ACC

See Table.21, [Adaptive Cruise Control and Active Brake Assist 5 Limitations](#) for a description of ABA5 and ACC limitations in specific driving conditions.

Adaptive Cruise Control and Active Brake Assist 5 Limitations	
Condition and Illustration	Description
<p style="text-align: center;">Cornering, entering and exiting bends</p>  <p>07/27/2022 f040877</p>	<p>The ability of ABA5 and ACC to react to vehicles on bends is limited.</p> <p>ABA5 and ACC may react to a vehicle or object in an adjoining lane and unexpectedly issue warnings or brake the vehicle.</p> <p>ABA5 and ACC may be slow to react to a vehicle or object previously hidden by a bend in the lane.</p> <p>ACC may also accelerate the vehicle unexpectedly if the vehicle ahead is hidden by a bend in the lane.</p>
<p style="text-align: center;">Vehicles not traveling in line with your vehicle and stationary vehicles</p>  <p>07/27/2022 f040883</p>	<p>The ability of ABA5 and ACC to react to vehicles not traveling in line with your vehicle and stationary vehicles is limited.</p> <p>ABA5 and ACC may react to a vehicle or object partially in your lane and unexpectedly issue warnings or brake your vehicle.</p> <p>ABA5 and ACC may be slow or fail to react to vehicles not traveling in line with your vehicle or stationary vehicles only partially in your lane.</p> <p>ACC may not detect and react to vehicles not traveling in line with your vehicle or stationary vehicles partially in your lane and may accelerate unexpectedly.</p>
<p style="text-align: center;">Other vehicles changing lanes</p>  <p>07/27/2022 f040884</p>	<p>The ability of ABA5 and ACC to detect and react to vehicles pulling into your lane without maintaining a safe distance is limited.</p> <p>ABA5 and ACC may be slow to react or fail to react to a vehicle entering your lane if the distance to the vehicle entering the lane is too short.</p> <p>ACC may accelerate unexpectedly if it fails to detect the vehicle entering the lane.</p> <p>If a vehicle cuts in front, brake your vehicle to increase the following distance.</p>

Table 21, Adaptive Cruise Control and Active Brake Assist 5 Limitations



Adaptive Cruise Control and Active Brake Assist 5 Limitations	
Condition and Illustration	Description
<p>Narrow vehicles changing lanes</p>  <p>07/27/2022 f040876</p>	<p>The ability of ABA5 and ACC to detect and react to narrow vehicles pulling into your lane is limited.</p> <p>Narrow vehicles may be slow to enter the system's detection range.</p> <p>ABA5 and ACC may be slow to react or fail to react to a critical driving situation due to the merging vehicle being slow to enter the system's detection range.</p> <p>ACC may accelerate unexpectedly if it fails to detect the vehicle entering the lane.</p>
<p>Vehicles turning off or in a nonstandard orientation.</p>  <p>07/27/2022 f040885</p>	<p>The ability of ABA5 and ACC to detect and react to vehicles turning off or vehicles in a nonstandard orientation is limited.</p> <p>ABA5 and ACC may react to a vehicle turning off and unexpectedly issue warnings or brake the vehicle.</p> <p>ABA5 and ACC may be slow or fail to react to a vehicle turning off or to a vehicle at an angle due to an accident even through there is a critical driving situation.</p>
<p>Overtaking</p>  <p>07/27/2022 f040879</p>	<p>The ability of ABA5 and ACC to detect and react to a vehicle you are overtaking is limited.</p> <p>When overtaking a vehicle, ABA5 and ACC may unexpectedly issue warnings or brake your vehicle if you drive too close to the vehicle you are overtaking before exiting that lane.</p>
<p>Winding stretches of road</p>	<p>On winding stretches of road, ABA5 and ACC cannot detect which lane the vehicle in front is driving in.</p>

Table 21, Adaptive Cruise Control and Active Brake Assist 5 Limitations

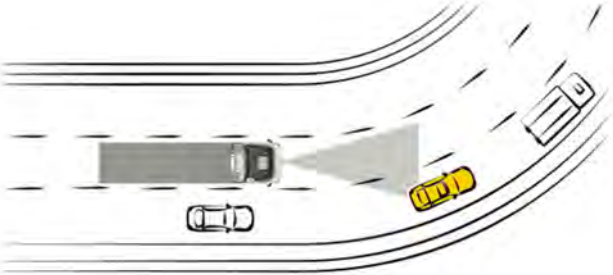
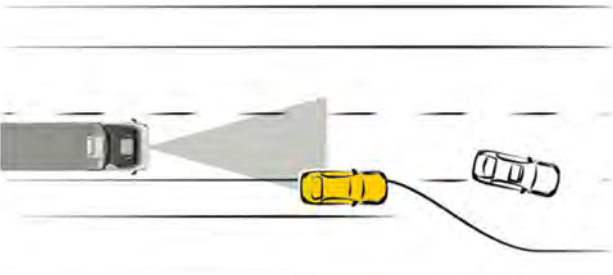
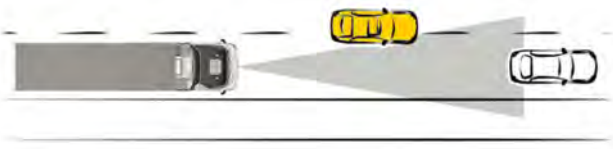
Adaptive Cruise Control and Active Brake Assist 5 Limitations	
Condition and Illustration	Description
 <p>07/27/2022 f040886</p>	<p>ABA5 and ACC may unexpectedly issue warnings or brake your vehicle when reacting to vehicles in a different lane.</p> <p>ABA5 and ACC may be slow to react or fail to react to a vehicle in your lane even through there is a critical driving situation.</p> <p>ACC may fail to detect the vehicle in front in your lane and may accelerate the vehicle unexpectedly.</p>
<p>Obstacles and stationary vehicles in front of a detected vehicle</p>  <p>07/27/2022 f040878</p>	<p>The ability of ABA5 and ACC to detect and react to objects when the detected vehicle turns off is limited.</p> <p>When the detected vehicle turns off, ABA5 and ACC may react to the obstacle or stationary vehicle that was in front of the detected vehicle and unexpectedly issue warnings or brake your vehicle.</p> <p>When the detected vehicle turns off, ABA5 and ACC may be slow to react or fail to react to an obstacle or stationary vehicle that was in front of the detected vehicle even though there is a critical driving situation.</p> <p>ACC may react to the vehicle turning off by accelerating unexpectedly.</p>
<p>Vehicles parked or broken down at the side of the road</p>  <p>07/27/2022 f040880</p>	<p>The ability of ABA5 and ACC to detect and react to a stationary vehicle on the side of the road is limited.</p> <p>ABA5 and ACC may unexpectedly issue warnings or brake your vehicle if it detects a vehicle on the side of the road.</p>

Table 21, Adaptive Cruise Control and Active Brake Assist 5 Limitations

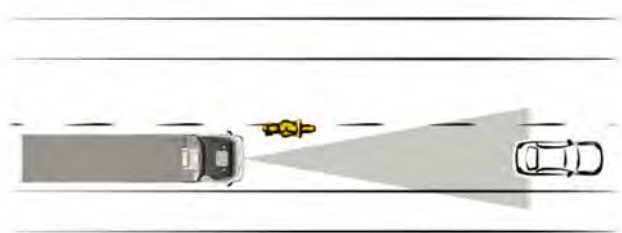
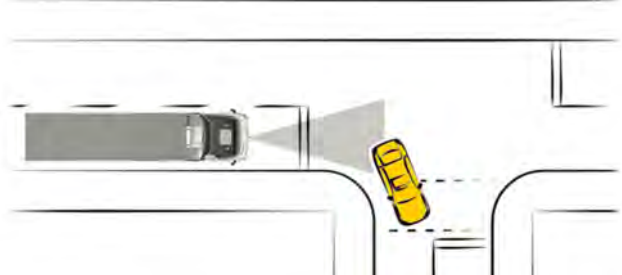
Adaptive Cruise Control and Active Brake Assist 5 Limitations	
Condition and Illustration	Description
<p style="text-align: center;">Stationary objects</p>  <p>07/27/2022 f040882</p>	<p>The ability of ABA5 and ACC to detect and react to stationary objects above, beside, and on the road is limited.</p> <p>ABA5 and ACC can unexpectedly issue warnings and brake the vehicle if it detects stationary objects beside, above, or in front of your lane such as:</p> <ul style="list-style-type: none"> • signs • traffic islands • some bridges, such as truss and cable bridges • low overpasses
<p style="text-align: center;">People</p>  <p>07/27/2022 f040881</p>	<p>The ability of ABA5 to detect and react to people in certain situations is limited.</p> <p>ABA5 can unexpectedly issue warnings and brake the vehicle if it detects and reacts to:</p> <ul style="list-style-type: none"> • people on the roadside on a curve • people walking beside the road • people in a tunnel

7.07 Detroit Assurance Side Guard Assist (SGA) and Active Side Guard Assist (ASGA)

7.07.01 General Information

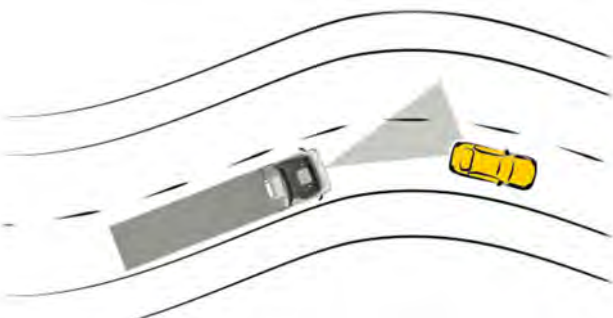
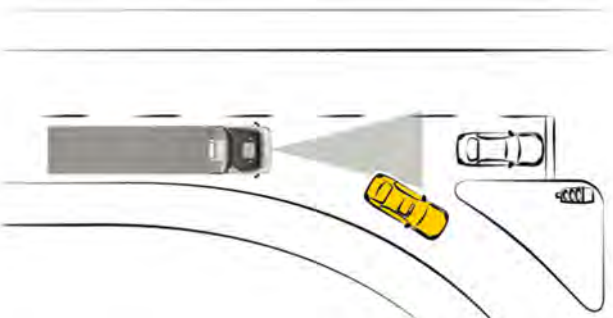
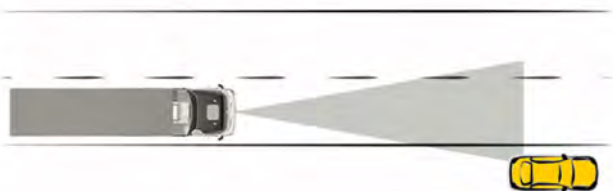
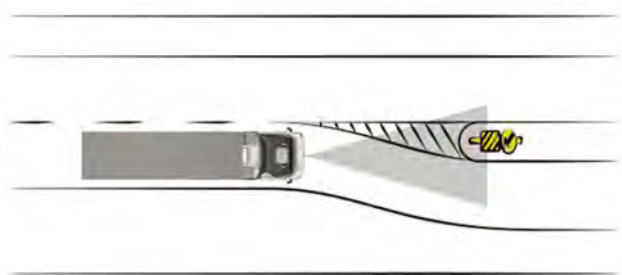
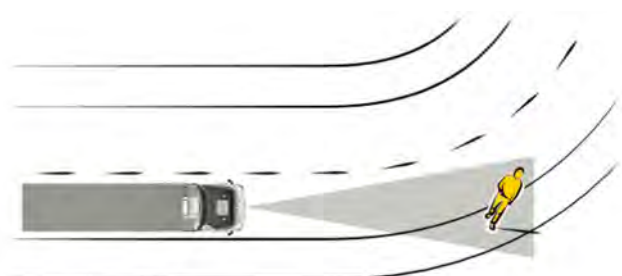
SGA provides assistance on the passenger-side of the vehicle while turning and changing lanes. SGA monitors the area on the passenger-side of the vehicle and trailer using two short range radar sensors. The radar sensors are mounted close to the rear of the passenger footsteps. See Fig.161, [Radar Sensors with Covers](#). The optional enhancement, ASGA, enables the brakes to automatically activate in certain low-speed passenger-side turns.

IMPORTANT: SGA is designed for use with one trailer attached to the tractor. The optional enhancement, ASGA, reacts only to moving objects within SGA's sensor monitoring area.

SGA detects if a trailer is attached to the tractor, but it cannot detect whether or not multiple trailers are attached. If used with more than one trailer, SGA only considers objects or stationary obstacles in the range of the tractor and the first trailer. False-positive indications and warnings may occur with multiple trailers.

IMPORTANT: SGA and its enhancement, ASGA, are not currently designed to work with non-ABS trailers or on trucks with steer lift axles.

A triangular warning lamp in the A-pillar is located near the side mirror. This lamp, as shown in Fig. 162, [SGA Warning Lamp](#), lights up to inform the driver that an object is detected in the monitored area. An additional warning tone sounds if there is a risk of collision.



12/07/2022

f548039

Fig 161, Radar Sensors with Covers

The ASGA engages at speeds less than 12 mph (19 km/h). If SGA detects a critical moving object in the sensor monitoring area along the side of the truck during a passenger-side turn, the ASGA automatically applies the brakes. The sensor monitoring area is shown in Fig. 163, [Sensor monitoring range of SGA](#).



12/07/2022

f548037

Fig 162, SGA Warning Lamp

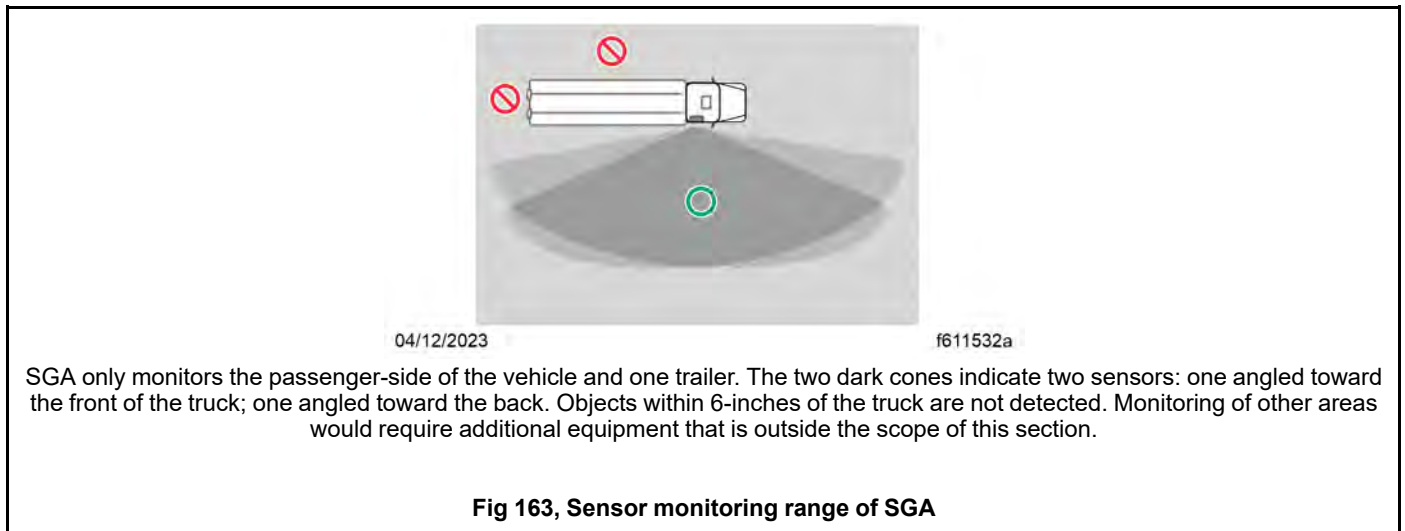

SGA only monitors the passenger-side of the vehicle and one trailer. The two dark cones indicate two sensors: one angled toward the front of the truck; one angled toward the back. Objects within 6-inches of the truck are not detected. Monitoring of other areas would require additional equipment that is outside the scope of this section.

7.07.02 Safety Information

SGA and ASGA are only aids for a conscientious driver. These guidelines serve as reminders for situations in which the driver must be especially alert and attentive. ASGA relies on SGA, if SGA is impaired, ASGA cannot provide notifications or assist during low speed, passenger-side turns when a critical object is present.

Before driving the vehicle, ensure the radar sensor cover is free from dirt, ice, or slush. If the sensors get dirty while driving, the telltale on the driver display may change from a grey triangle indicating active SGA to a grey triangle with a slash. In this case, pull off to a safe location to clean them. The radar sensors must be free of paint or other coverings such as stickers.



WARNING:

If detection is impaired, SGA may issue a warning too late or not at all. The following conditions can restrict detection of obstacles:

- dirty, icy, or obscured sensors
- very wide lanes
- vehicles not driving in the middle of their lane
- barriers or other road boundaries

The risk of an accident is increased in these situations.

The driver must pay attention to the traffic situation and maintain a safe distance at the side of the vehicle.

IMPORTANT: If the sensors are dirty or SGA malfunctions, a grey triangle alert icon with a slash or exclamation mark appears on the driver display. SGA has stopped tracking objects in the monitoring range and notifications are not available

Depending on the situation and the trailer, SGA may issue a warning prematurely or not at all. In addition to unobstructed sensors, always ensure the distance to the side for other vehicles, cyclists, pedestrians, and obstacles is sufficient.

Be cautious and attentive in the following scenarios. SGA notifications may be delayed, inactive, in error, or interrupted.

- May be inactive a short duration after coupling; the ability to activate it is delayed.

- May be inactive for a short duration after pulling away from a loading dock.
- During passenger-side turns, monitoring becomes limited for the end of the trailer and the back corner or bumper. Extra attentiveness is required.
- Inactive on objects within approximately 6 inches of the passenger-side of the vehicle and trailer. Objects within this area are not detected.
- Inactive on objects that are alongside a second trailer.
- In error when driving close to barriers or other solid boundaries. For example driving through construction sites, see Activating and Deactivating SGA for more information.
- Interrupted during prolonged driving alongside particularly long vehicles.

See an authorized dealer to have the function of the radar sensors checked if any of the following circumstances are true:

- If the vehicle is involved in a severe accident.
- If there is damage to the passenger-side footsteps.
- If the needs servicing telltale, a grey triangle with an exclamation mark, appears in the driver's display.
- If SGA malfunctions.

The active monitoring areas are shown in Fig.164, [Sensor monitoring range of SGA](#).

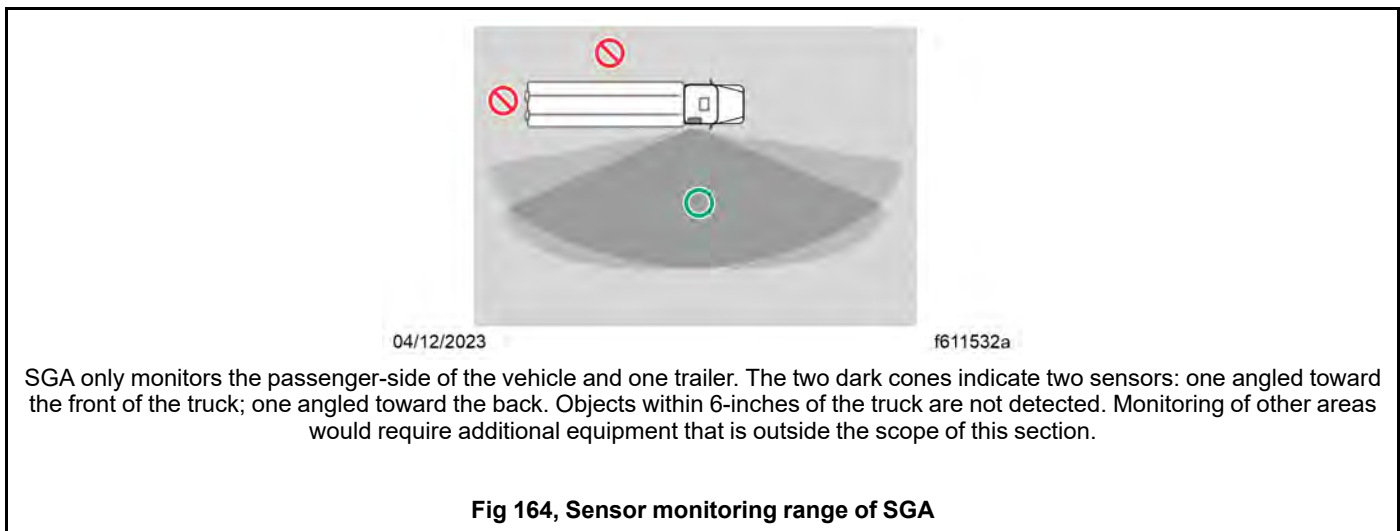

SGA only monitors the passenger-side of the vehicle and one trailer. The two dark cones indicate two sensors: one angled toward the front of the truck; one angled toward the back. Objects within 6-inches of the truck are not detected. Monitoring of other areas would require additional equipment that is outside the scope of this section.

7.07.03 Sensor Monitoring Range of SGA

The sensor monitoring range is the area on the passenger-side of the vehicle that the sensors can assess for proximity of moving objects and stationary obstacles.

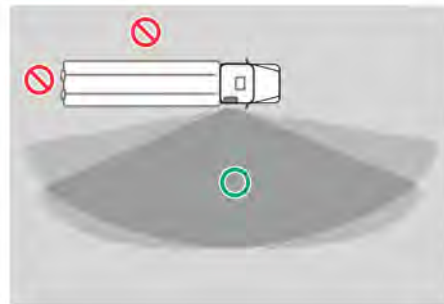

04/12/2023

f611532a

SGA only monitors the passenger-side of the vehicle and one trailer. The two dark cones indicate two sensors: one angled toward the front of the truck; one angled toward the back. Objects within 6-inches of the truck are not detected. Monitoring of other areas would require additional equipment that is outside the scope of this section.

Fig 165, Sensor monitoring range of SGA

SGA only monitors the passenger-side of the vehicle and one trailer. The two dark cones indicate two sensors: one angled toward the front of the truck; one angled toward the back. Objects within 6-inches of the truck are not detected. Monitoring of other areas would require additional equipment that is outside the scope of this section.

7.07.04 SGA Indicator Lamps

NOTE: The telltales described as grey may appear white depending on the type of instrument panel installed in the vehicle. Amber telltales raise awareness of an object. Red telltales warn of a possible collision. See Fig. 166, [SGA Telltale Locations, ICUC](#).

On start up, the driver knows the vehicle is equipped with the SGA if the SGA icon appears in the Detroit Assurance screen along with ABS. An SGA initializing telltale, the first telltale in See Table.22, [Side Guard Assist Telltales](#), appears on the driver display as the startup sequence continues.

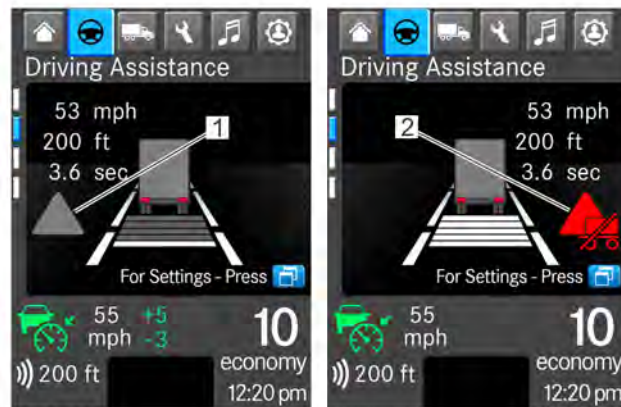

07/21/2022

f612096

In a left-hand drive vehicle, the SGA activation state (grey) telltale appears to the left of center on the driver display driving assistance screen; the amber (not shown) and red warning telltales appear to right of center.

- 1. Location of SGA Activation State (Grey) Telltale
- 2. Location of SGA Warning Telltales

Fig 166, SGA Telltale Locations, ICUC

In a left-hand drive vehicle, the SGA activation state (grey) telltale appears to the left of center on the driver display driving assistance screen; the amber (not shown) and red warning telltales appear to right of center.

After startup, the driver display shows the status of the SGA and the conditions detected. If a trailer is not attached to the tractor, a grey triangle appears on the driver display screen as shown in Fig. 6.29. If a trailer is attached, a grey triangle with trailer appears.

If the SGA monitoring experiences an error or is deactivated without a trailer attached, a grey triangle with a slash appears.

If the SGA monitoring is deactivated with a trailer attached, a triangle with a trailer and a slash appears.

NOTE: When the transmission is shifted to reverse, the SGA OFF telltale appears in the display until the transmission is shifted back to Neutral (N) or forward gears.

After the SGA is turned off, it remains off until the driver turns the SGA feature on using the driver display or by stopping and turning the vehicle off and on again. When the vehicle is running and the SGA is turned off, the driver display shows the Side Guard Assist Error or Deactivation telltales.

Alerts are color-coded to indicate severity. Red indicates a condition that may pose a threat to control of the vehicle. Amber indicates a condition that may result in damage to vehicle components or derating of engine power. Grey is used for notices.



Name	Telltale	Color
Side Guard Assist Initializing	 <p data-bbox="737 1083 824 1115">Fig 167,</p>	Grey
Side Guard Assist Active	 <p data-bbox="737 1423 824 1455">Fig 168,</p>	Grey
Side Guard Assist Error or Deactivation	 <p data-bbox="737 1759 824 1791">Fig 169,</p>	Grey

Table 22, Side Guard Assist Telltales





<p>Side Guard Assist Trailer Monitoring Active</p>	 <p>Fig 170,</p>	<p>Grey</p>
<p>Side Guard Assist Trailer Monitoring Deactivated</p>	 <p>Fig 171,</p>	<p>Grey</p>
<p>Side Guard Assist Needs Servicing</p>	 <p>Fig 172,</p>	<p>Grey</p>
<p>Caution, Side Guard Assist</p>	 <p>Fig 173,</p>	<p>Amber</p>
<p>Caution, Side Guard Assist Trailer</p>	 <p>Fig 174,</p>	<p>Amber</p>

Table 22, Side Guard Assist Telltales





<p>Caution, Side Guard Assist Trailer Monitoring Deactivated</p>	 <p>Fig 175,</p>	<p>Amber</p>
<p>Warning, Side Guard Assist</p>	 <p>Fig 176,</p>	<p>Red</p>
<p>Warning, Side Guard Assist Trailer</p>	 <p>Fig 177,</p>	<p>Red</p>
<p>Warning, Side Guard Assist Trailer Monitoring Deactivated</p>	 <p>Fig 178,</p>	<p>Red</p>

Table 19, Side Guard Assist Telltales

7.07.05 Activating and Deactivating Side Guard Assist

SGA becomes active when the ignition is turned on. The driver controls its setting using the driver assistance screen of the ICU also known as the digital switch or a physical switch if equipped.

In some operational conditions, such as construction zones, SGA may register false positives. Vehicles built from January 2023 have an optional SGA OFF physical switch as shown in Fig.167, [Physical SGA OFF Switch](#).

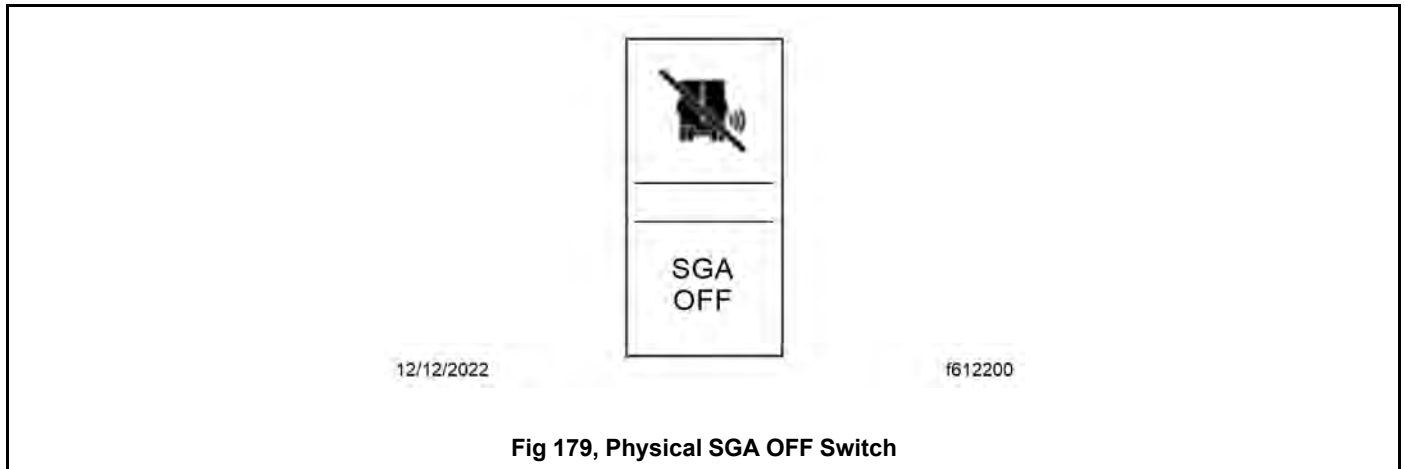

Fig 179, Physical SGA OFF Switch

While the vehicle is running and SGA is OFF, the driver display shows the side guard assist deactivation or error telltales as shown in Fig.23, [Side Guard Assist Telltales](#).

After SGA is turned off, it remains off until the driver turns the SGA feature ON using one of the following:

- the switch, if equipped,
- the driver assistance screen on the driver display,
- stopping and turning the vehicle off and on again.

SGA is automatically activated when the ignition is turned on. The ASGA relies on SGA and its activation is not controlled separately by the driver. The ASGA engages at speeds less than 12 mph (19 km/h). If SGA detects a critical moving object in the sensor monitoring area along the side of the truck during a passenger-side turn, the ASGA automatically applies the brakes.

Although monitoring is continuous, the audible and visual alerts can be deactivated fully or partially. With the default setting, the SGA notifications are active for both the vehicle and the trailer as shown in Fig.

168, [Notification Zones for SGA and Trailer Assist While Activated](#).. Stationary and moving objects detected within range activate cautions and warnings.

If the digital settings for the trailer are deactivated, notifications are deactivated for the range indicated as a red circle with a slash shown in Fig.169, [Notifications Zones for SGA Active and Trailer Assist Deactivated](#)..

A driver can override SGA and ASGA during a braking event by pressing the accelerator pedal beyond the pressure point to engage kickdown.

The driver can keep the default settings for SGA notifications to alert for objects within the range of the vehicle and the trailer; or filter out objects detected on the passenger-side of the trailer. Also, the notifications can be deactivated for both.

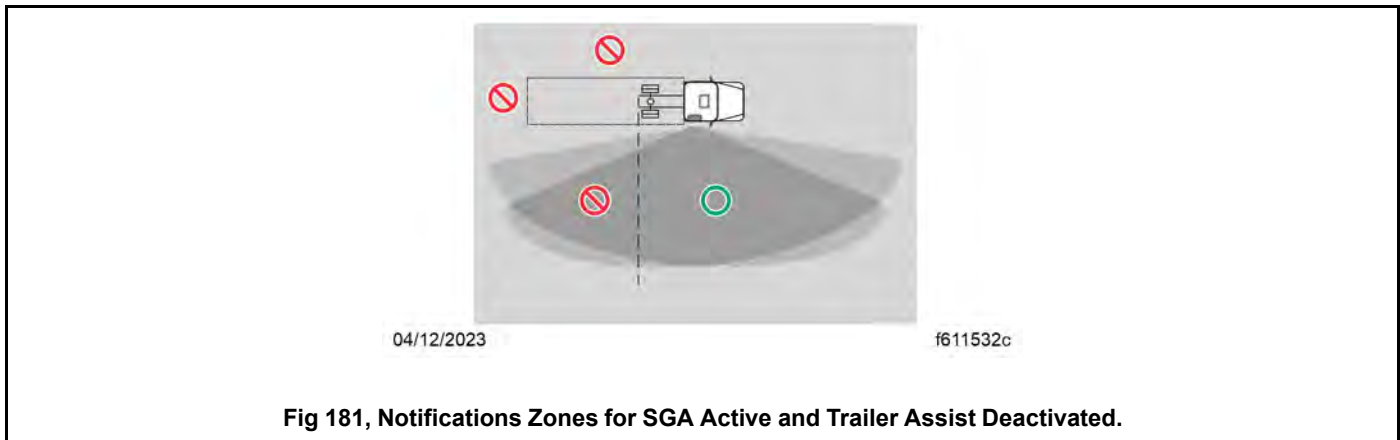
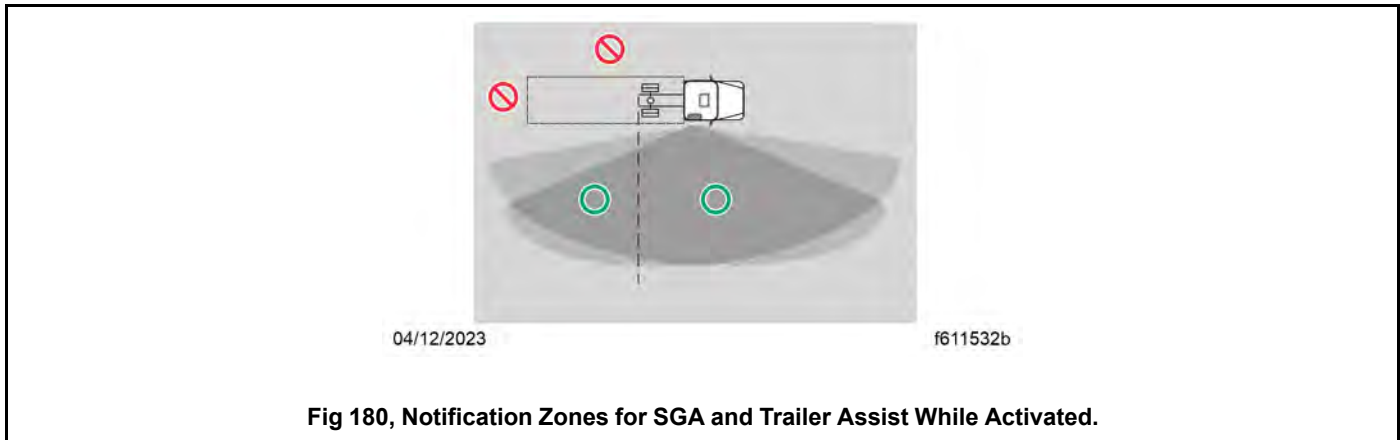

In some operational conditions, such as construction zones, SGA may register false positives. The driver can turn SGA alerts off manually for the truck and trailer using the driver assistance settings of the driver display. If SGA is off, the trailer monitoring is off. The driver can keep SGA on for the vehicle and deactivate the trailer alerts.

After stopping safely, the driver can use the driver display to change the alert settings. For vehicles equipped with ICUC, the settings are shown in Fig. 170, [Deactivation of SGA in the Driver Display, ICUC](#) and see Fig. 171, [Deactivation of Trailer Assist in the Driver Display, ICUC](#).

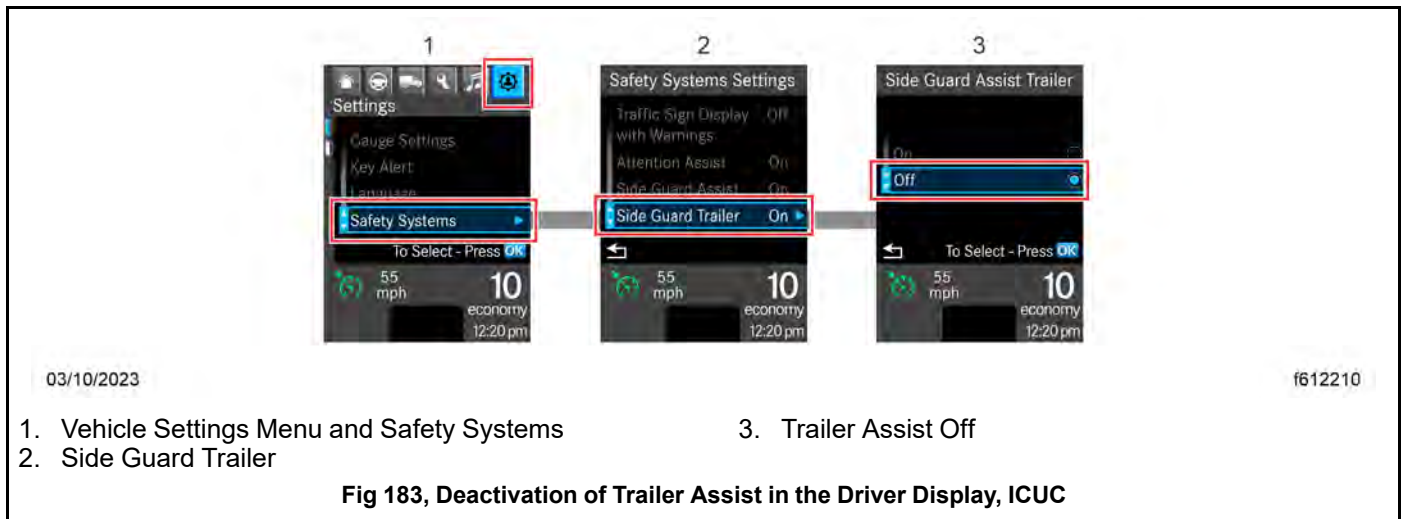
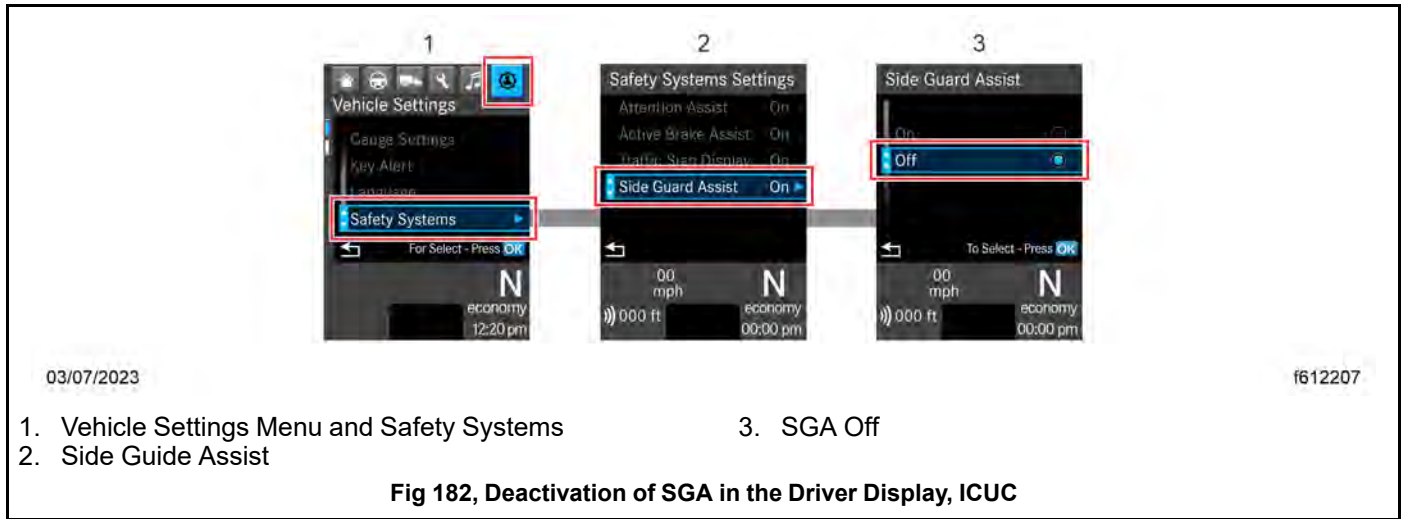

For vehicles equipped with ICC5, the display has digital toggles for turning features on and off. The alert settings are shown in Fig.172, [Deactivating SGA in the Driver Display, ICC5](#) and see Fig. 173, [Deactivating SGA Trailer in the Driver Display, ICC5](#).

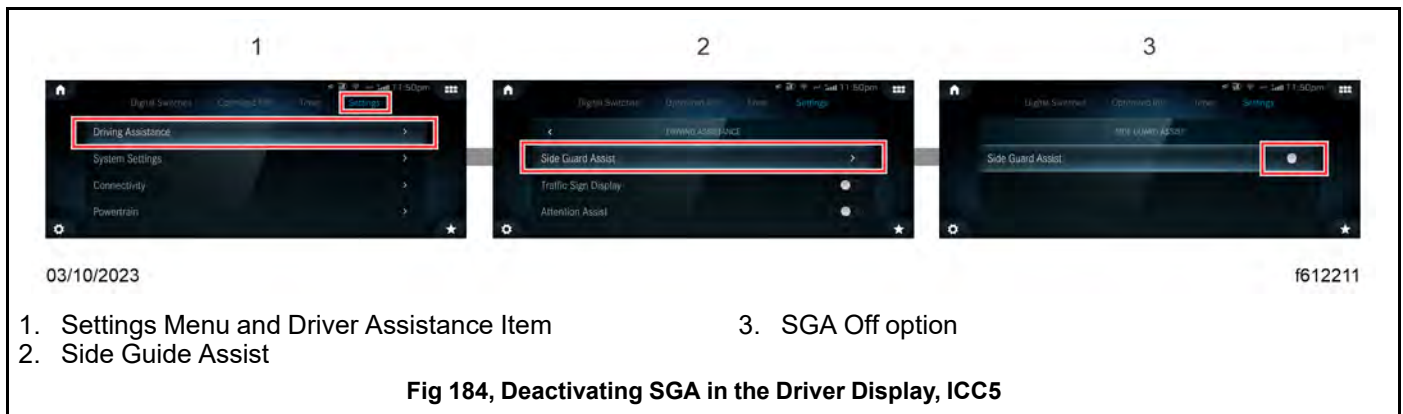

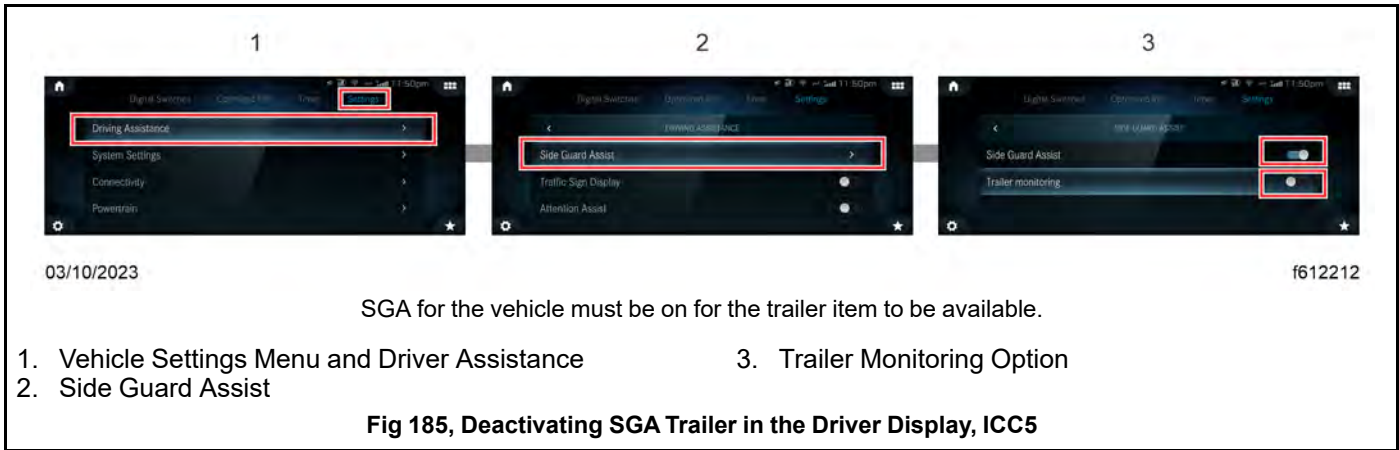

SGA for the vehicle must be on for the trailer item to be available.



Name	Telltale	Color
Side Guard Assist Initializing	 <p style="text-align: center;">Fig 186,</p>	Grey
Side Guard Assist Active	 <p style="text-align: center;">Fig 187,</p>	Grey
Side Guard Assist Error or Deactivation	 <p style="text-align: center;">Fig 188,</p>	Grey

Table 23, Side Guard Assist Telltales





<p>Side Guard Assist Trailer Monitoring Active</p>	 <p>Fig 189,</p>	<p>Grey</p>
<p>Side Guard Assist Trailer Monitoring Deactivated</p>	 <p>Fig 190,</p>	<p>Grey</p>
<p>Side Guard Assist Needs Servicing</p>	 <p>Fig 191,</p>	<p>Grey</p>
<p>Caution, Side Guard Assist</p>	 <p>Fig 192,</p>	<p>Amber</p>
<p>Caution, Side Guard Assist Trailer</p>	 <p>Fig 193,</p>	<p>Amber</p>

Table 23, Side Guard Assist Telltales





<p>Caution, Side Guard Assist Trailer Monitoring Deactivated</p>	 <p>Fig 194,</p>	<p>Amber</p>
<p>Warning, Side Guard Assist</p>	 <p>Fig 195,</p>	<p>Red</p>
<p>Warning, Side Guard Assist Trailer</p>	 <p>Fig 196,</p>	<p>Red</p>
<p>Warning, Side Guard Assist Trailer Monitoring Deactivated</p>	 <p>Fig 197,</p>	<p>Red</p>

Table 20, Side Guard Assist Telltales

7.07.06 Driving Scenarios and SGA Warnings

IMPORTANT: SGA is only an aid. The system may fail to detect some objects and does not substitute for attentive driving. Always ensure that sufficient distance is to the side for vehicles, cyclists, pedestrians, and obstacles.

The scenarios shown in Table.24, [Common Scenarios for Warnings While SGA and Trailer Assist are Activated](#). assume both SGA Assist and Trailer Assist are active. If SGA is off in any of these scenarios, the driver does not experience the notifications mentioned. If SGA Trailer Assist is off, in the last scenario, the visual and audible warnings would not occur.

Warning Scenarios	Driver Experience
 <p>10/11/2018 f611533</p> <p style="text-align: center;">Fig 198,</p>	<p>Moving object detected along side the vehicle and trailer.</p> <p>An amber SGA warning lamp in the A-pillar activates and the ICU displays the appropriate caution telltale.</p>
 <p>10/11/2018 f611534</p> <p style="text-align: center;">Fig 199,</p>	<p>Moving detected while turning.</p> <p>If the driver signals or steers to the passenger-side and there is a risk of collision with an object, the red SGA warning lamp in the A-pillar flashes for a few seconds, a warning tone sounds, and the appropriate SGA warning telltale on the driver display screen. After flashing, the red warning lamp stays on as long as there is a risk of a collision.</p> <p>If the vehicle is moving at urban speeds and equipped, ASGA automatically applies the brakes.</p>

Table 24, Common Scenarios for Warnings While SGA and Trailer Assist are Activated

 <p>04/19/2023 f612213a</p> <p>Fig 200,</p>	<p>Limitations to detection of risk to the trailer's back corner while turning.</p> <p>The ability of SGA and ASGA to detect and react to stationary objects alongside the end of the trailer as it completes a passenger-side turn is limited. If the driver steers to the passenger-side there is a risk of collision without notification when the end of the trailer and its bumper reaches a stationary object.</p>
 <p>10/11/2018 f611535</p> <p>Fig 201,</p>	<p>Moving object detected by vehicle sensor before a lane change.</p> <p>If a moving object is in SGA monitoring range when a driver signals or steers to the passenger-side, an amber warning lamp activates in the A-pillar and the appropriate SGA caution telltale appears on the driver display screen.</p> <p>If there is a risk of collision, the red warning lamp in the A-pillar flashes, a warning tone sounds, and the appropriate SGA warning telltale appears on the driver display screen. The red warning lamp stops flashing after a few seconds but stays on as long as there is a risk of a collision.</p>
 <p>10/11/2018 f611536</p> <p>Fig 202,</p>	<p>Moving object detected by trailer sensor before a lane change.</p> <p>SGA warns the driver about stationary obstacles in the vehicle's range of movement up to a maximum speed of 22 mph (35 km/h).</p> <p>If there is a risk of collision with a stationary obstacle when turning, the red warning lamp in the A-pillar flashes, a warning tone sounds, and the appropriate SGA warning telltale appears on the driver display screen. The red warning lamp stops flashing after a few seconds but stays on as long as there is a risk of a collision.</p>

Table 21, Common Scenarios for Warnings While SGA and Trailer Assist are Activated

7.08 Detroit Assurance Traffic Sign Display

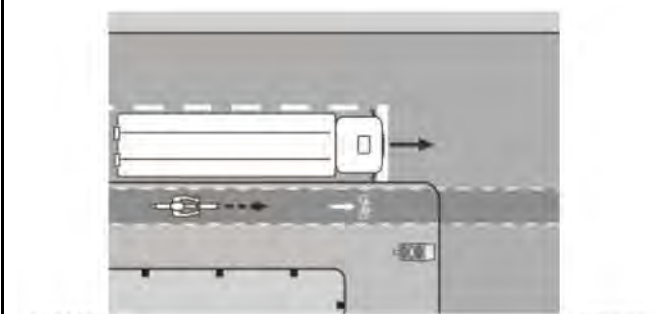
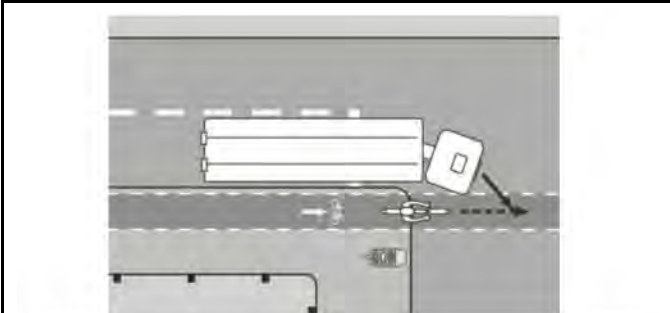
7.08.01 General Information

NOTE: Traffic Sign Display requires IPM to function.

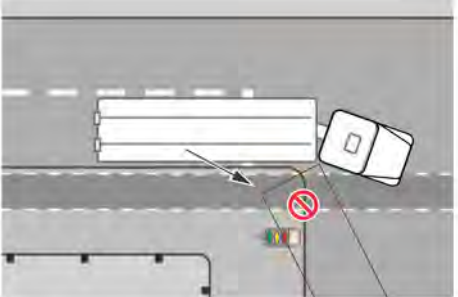
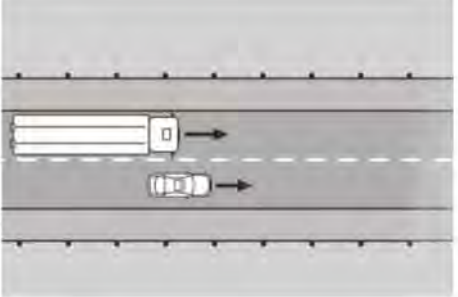
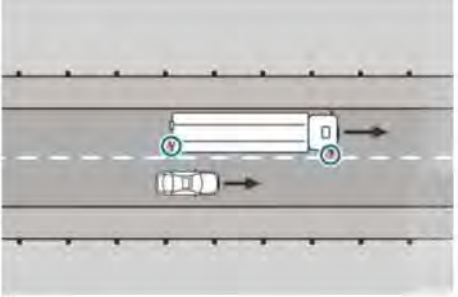
If equipped, the Detroit Assurance Traffic Sign Display system increases road safety by making the driver aware of posted traffic signs. Traffic sign display uses video data from the multipurpose camera in combination with GPS map data to recognize USA and Canadian traffic signs and display them in the instrument panel. GPS information dictates the language and style of the sign display.

7.08.02 Safety Information

Traffic sign recognition and display is only intended as an aid for a conscientious and alert driver. The system may not operate as designed under the following conditions:

- there is low visibility, due to insufficient road illumination or due to snow, rain, fog, or heavy spray;
- there is glare from oncoming traffic, the sun, or reflection from other vehicles when the road surface is wet;
- the windshield is dirty, misted up, damaged, or covered, for instance by a sticker in the vicinity of the camera;
- the traffic signs are partly or fully covered by other vehicles, bushes, or trees;
- the traffic signs are designed in a non-standardized form, with additional text, or as LED panels;
- the traffic signs are damaged, bent, twisted, stained, or scratched;
- the distance from the vehicle in front is too small and prevents the traffic signs from being detected in time;
- the traffic signs are posted on the far side of the road or very high above the road;
- the road is very wide, winding, or has sharp turns;
- there are variable shade conditions on the road surface;
- GPS satellite reception is limited for some reason, such as geographical location;
- onboard map data is outdated due to recent changes in local traffic regulations or new road layout.

The traffic sign recognition system cannot take the road and weather conditions into account, nor the current traffic situation. The driver is responsible for the distance to the vehicle in front, for vehicle speed, braking in good time and remaining in the lane.

7.08.03 Traffic Sign Display Functionality

NOTE: Only three types of USA and Canadian traffic signs are currently detected:

- Speed Limit signs (from speeds 5 to 140)
- Passing signs
- Exclusion signs

See Fig. 174, [Recognized Traffic Signs, USA](#) for currently recognized USA signs and Fig. 175, [Recognized Traffic Signs, Canada](#) for Canadian signs.

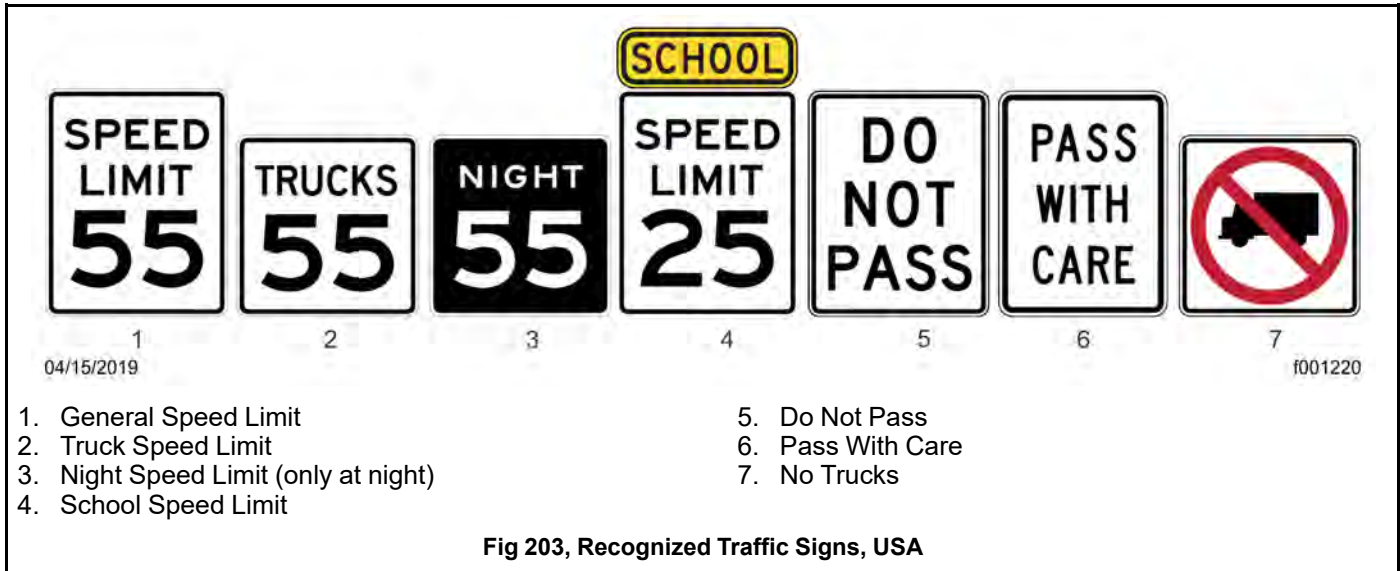

When a traffic sign is recognized by the system, an image representing it appears in the instrument panel. See Fig. 176, [Traffic Sign Display - ICUC](#) and Fig. 177, [Traffic Sign Display - ICC5](#). The ICU will display up to two traffic signs at a time. If more than two signs are recognized by the system, the most safety critical signs will be displayed.

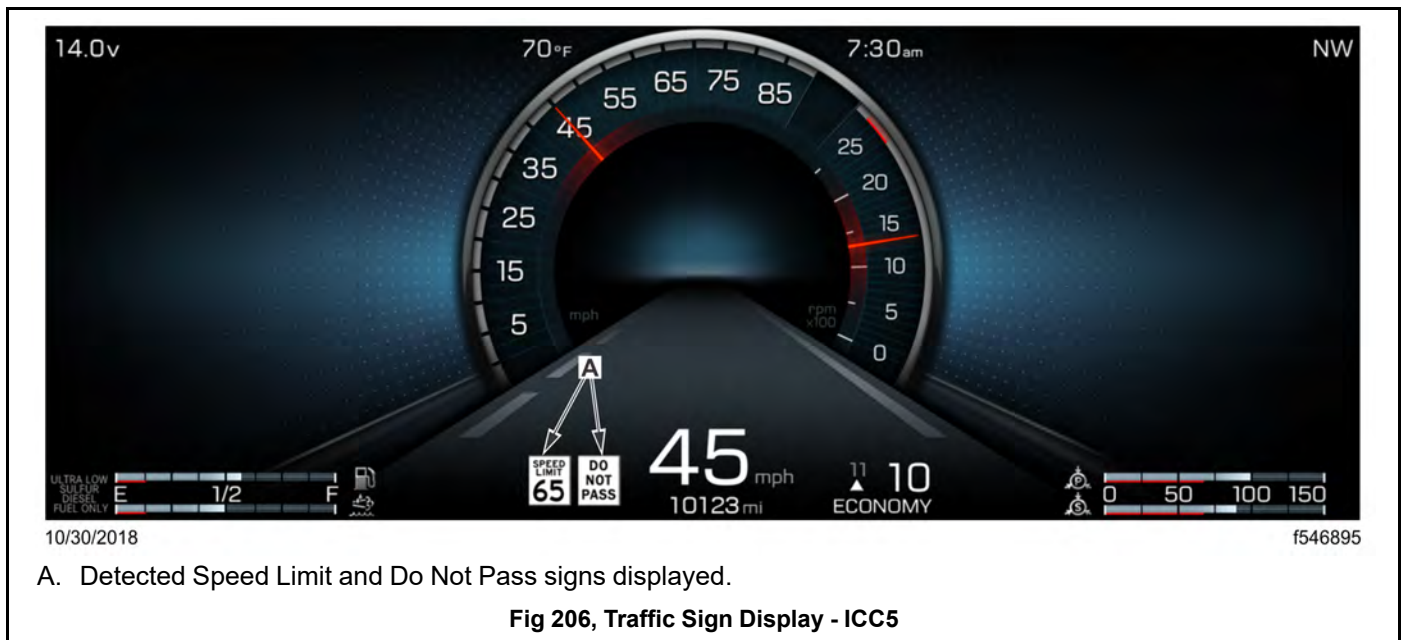
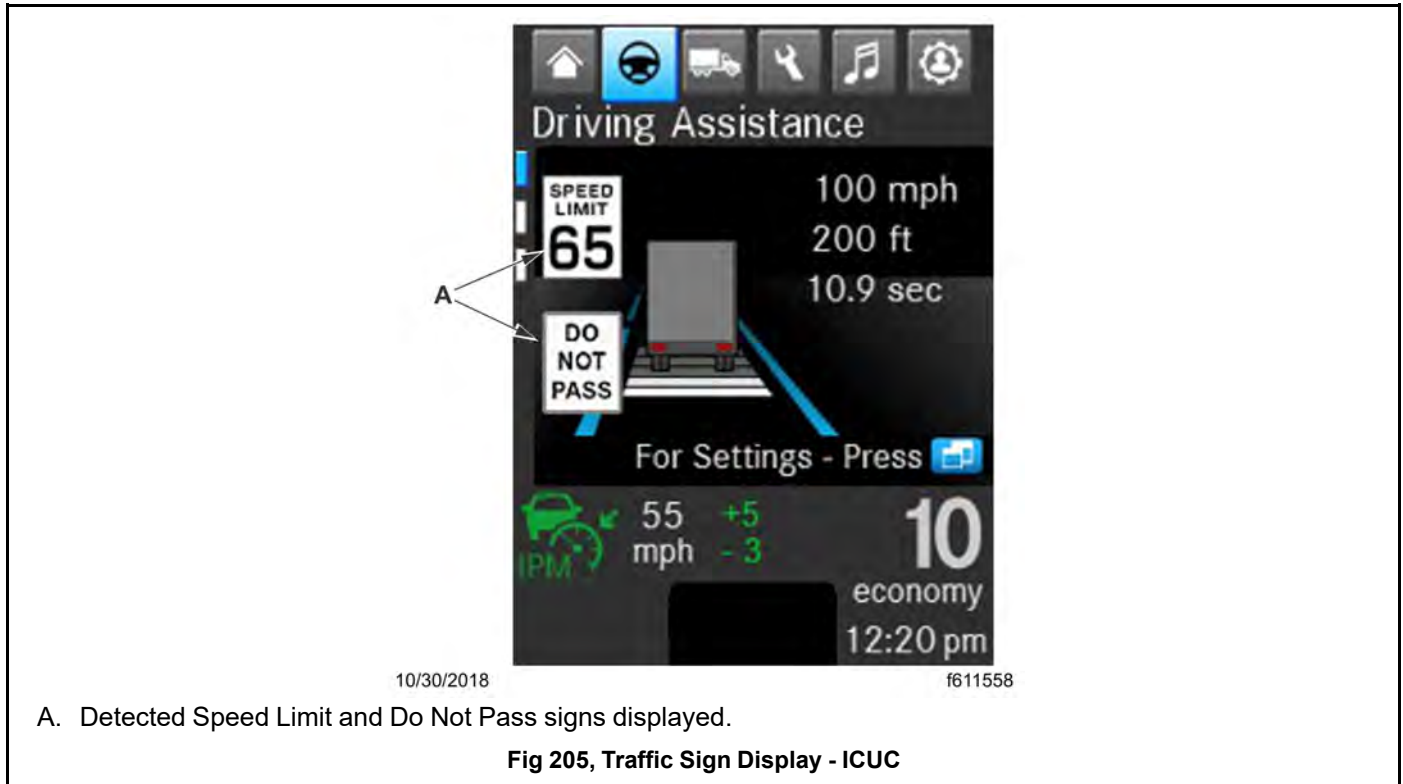

7.08.04 Activating or Deactivating

Traffic Sign Display can be activated or deactivated via menu options in the ICU system.

To activate Traffic Sign Display in an ICUC system:

1. Navigate to "Drive Time Systems."

2. Go to "Safety System Settings."
3. Go to "Sign Recognition."
4. Select "On."

Select 'Off' to deactivate traffic sign display.

To activate Traffic Sign Display in an ICC5 system:

1. Press the center button in either of the steering wheel OFN control buttons
2. Select the "Settings" (gear) icon.
3. Select "Driving Assistance."
4. Go to "Traffic Sign Recognition."
5. Move the selector switch icon to the "On" position (a blue line will appear to the left).

Move the selector switch icon to the 'Off' position to deactivate traffic sign recognition and display

When the ignition is turned on, traffic sign display restores the state of the system (either activated or deactivated) from the last ignition cycle.

- 8.01 Standard Cruise Control 188
 - 8.01.01 General Description, Standard Adaptive Cruise Control 188
 - 8.01.02 Using Standard Adaptive Cruise Control 190
- 8.02 Cruise Descent Control and Deceleration Modes 190
 - 8.02.01 General Description, Cruise Descent Control and Deceleration Modes 190
 - 8.02.02 Descent Control Mode 191
 - 8.02.03 Deceleration Mode 193
- 8.03 Hill Start Aid 193
- 8.04 Brake Hold 194
- 8.05 Intelligent Powertrain Management (IPM) 195
- 8.06 PasSmart 197
- 8.07 Electronic Stability Control (ESC) 198
- 8.08 SafetyDirect® by Bendix 199
 - 8.08.01 Bendix Forward Facing Camera 199
 - 8.08.02 Driver Facing Camera 199
 - 8.08.03 The Bendix SafetyDirect Portal 199
- 8.09 Lytx SF500 DriveCam System 200
 - 8.09.01 Driver Facing Camera 200

8. Driver Assistance Features

8.01 Standard Cruise Control

8.01.01 General Description, Standard Adaptive Cruise Control



WARNING:

Do not use the cruise control system when driving conditions do not permit maintaining a constant speed, such as in heavy traffic or on roads that are winding, icy, snow-covered, slippery, or roads with a loose driving surface. Failure to follow this precaution could cause a collision or loss of vehicle control, possibly resulting in personal injury or property damage.



NOTICE:

When the cruise control is engaged, do not attempt to shift gears without using the clutch pedal. Failure to follow this precaution will result in a temporarily uncontrolled increase in engine speed. Transmission damage and gear stripping could result.

NOTE: If the vehicle is equipped with a Detroit DT12 automated transmission, setting the cruise control with the engine brake on will activate cruise descent control mode. Moving the transmission shift lever to the top position will resume the set cruise speed. Moving the lever down to engage the engine brake after the cruise control has been set will activate deceleration mode. See 'Cruise Descent Control and Deceleration Modes' in this chapter.

In the ICUC, standard cruise control is operated by three switches mounted in the right-hand switch pod of the steering wheel. See Fig.178, [Steering-Wheel-Mounted Right-Hand Switch Pod, ICUC](#).



11/18/2022

f611352e

- | | |
|---------------------------------|--|
| 1. Cruise Accelerate/Resume | 5. Marker Interrupt (not available in all markets) |
| 2. Quick Access System Settings | 6. Phone Pick-Up |
| 3. Cruise Decelerate/Set | 7. Headlamp Interrupt (not available in all markets) |
| 4. Phone Hang-Up/Reject | 8. Cancel Cruise Control |

Fig 207, Steering-Wheel-Mounted Right-Hand Switch Pod, ICUC

In the ICC5, standard cruise control is operated by three buttons mounted in the left-hand pod of the steering wheel. See Fig.179, [Steering-Wheel-Mounted Left-Hand Switch Pod, ICC5](#).

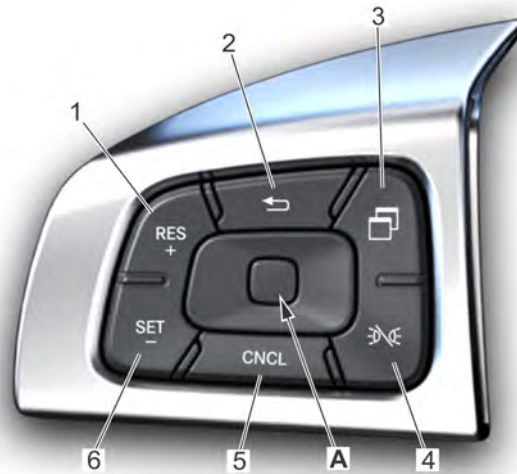

10/25/2018

f611531a

- | | |
|--|--|
| <ul style="list-style-type: none"> A. Menu Button Press the button to access instrument panel menus. When the button is pressed, information appears on the driver display screen. 1. Cruise Accelerate/Resume 2. Back Button | <ul style="list-style-type: none"> 3. Quick Access System Settings 4. Marker Interrupt 5. Cruise Cancel 6. Cruise Decelerate/Set |
|--|--|

Fig 208, Steering-Wheel-Mounted Left-Hand Switch Pod, ICC5

- Cruise Decelerate/SET Button Press to set the cruise speed while the vehicle is traveling at the desired speed. Press and hold to decrease the set cruise speed by 5 mph increments (Detroit Diesel engines only). Single press decreases cruise speed by 1 mph. When cruise control has been set, the driver display static menu in the ICUC shows relevant cruise control icons and the set speed. See Fig.180, [Static Menu, ICUC](#). The speed memory will be retained until the ignition is turned off.

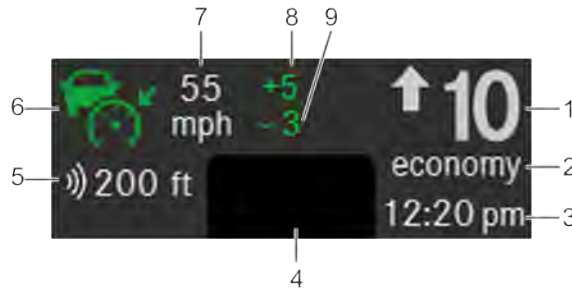

06/13/2016

f611364

- | | |
|--|---|
| <ul style="list-style-type: none"> 1. Gear Indicator 2. Gear mode 3. Time 4. Soft Telltale Area 5. Adaptive Cruise Control Following Distance | <ul style="list-style-type: none"> 6. Adaptive Cruise Control Telltale 7. Cruise Control Set Speed 8. Cruise Control Overspeed Amount 9. Cruise Control Underspeed Amount |
|--|---|

Fig 209, Static Menu, ICUC

- CNCL Button Press to pause the cruise control, while retaining the speed setting in memory. The cruise control can also be disengaged, while retaining the speed memory, by depressing the brake or clutch pedals.

- Cruise Accelerate/RES Button Press to resume the set speed. Press and hold to increase the set cruise speed by 5 mph increments (Detroit Diesel engines only). Single press increases cruise speed by 1 mph. If no previous set speed is stored, pressing the button sets the cruise speed.

8.01.02 Using Standard Adaptive Cruise Control

1. To cruise at a particular speed:
 - 1.a Depress the accelerator pedal until the speedometer reaches the desired speed.
 - 1.b Press the cruise decelerate/SET button to set the desired speed.

NOTE: The set speed memory is lost whenever the ignition is turned off.

2. To disengage the cruise control, do one of the following:
 - Press the CNCL button in the center of the right-hand steering-wheel-mounted switch pod. A single press disengages the cruise control, but retains the set speed.
On vehicle's equipped with a Detroit Diesel engine, press and hold the CNCL button to clear the set speed.
 - In the ICC5 system, press the CNCL button at the bottom of the left-hand control pod. A single press disengages the cruise control, but retains the set speed.
On vehicle's equipped with a Detroit Diesel engine, press and hold the CNCL button to clear the set speed.
 - Depress the brake pedal.
 - If equipped with a manual transmission, press the clutch pedal.
3. To resume a preselected cruise speed, press the cruise accelerate/RES button. Cruise will return to the last set speed.

NOTE: If vehicle speed drops below the minimum cruise control speed, cruise control will disengage. To resume to the preselected cruise speed, increase vehicle speed to above minimum cruise control speed and press the cruise accelerate/RES button.

4. To increase cruise speed, press the cruise accelerate/RES button until the desired set speed is displayed.
5. To decrease cruise speed, press the cruise decelerate/SET button until the desired set speed is displayed.

The cruise speed hysteresis (maximum speed above and below the set speed) can be set in the ICU settings menu. The leading vehicle following distance can be set using the quick access button.

8.02 Cruise Descent Control and Deceleration Modes

8.02.01 General Description, Cruise Descent Control and Deceleration Modes

NOTE: As a feature of cruise control, descent control mode will work with all transmission options; however, cruise control can only request a specific gear if the vehicle is equipped with a DT12. Descent control mode with transmissions other than D12 is therefore limited.

On vehicles equipped with a Detroit DT12 automated transmission, the functions of the engine brake controls change, depending on which specialty braking mode is being utilized. Two distinct modes can be activated:

- **Descent control mode:** engine braking attempts to maintain a set speed; the accelerator pedal is not automatically applied. Setting the cruise control speed with the engine brake on will activate cruise descent control mode. Moving the transmission shift lever to the top position will resume the set cruise speed.

- **Deceleration mode:** engine braking activates to reduce vehicle speed (with no lower limit) at a constant rate. Moving the transmission shift lever down to engage the engine brake after the cruise control has been set will activate deceleration mode.

8.02.02 Descent Control Mode

NOTE: Before engaging descent control, determine an appropriate speed for the vehicle's load and grade of the road.

Descent control mode attempts to keep the vehicle speed at the set speed using all available engine brake stages when descending a grade.

To activate descent control mode:

1. Exit cruise control.
2. Remove your foot from the accelerator pedal.
3. Set the engine brake to any of the three 'on' positions (positions 1, 2, or 3 in Fig. 181, [Descent Control Mode Engine Brake Positions](#)).
4. Use the set or resume buttons to set the vehicle speed.

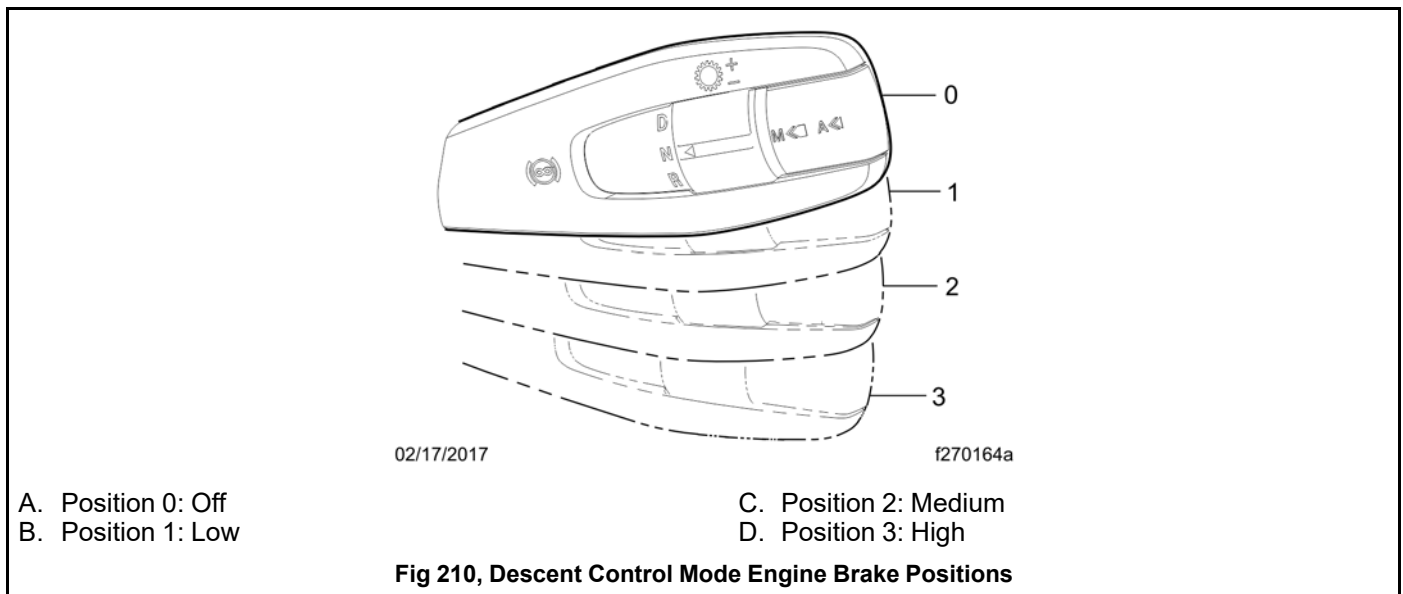

The descent control mode active telltale illuminates on the driver display when descent control mode is active. See Fig. 182, [Descent Control Mode Telltale, ICUC](#).

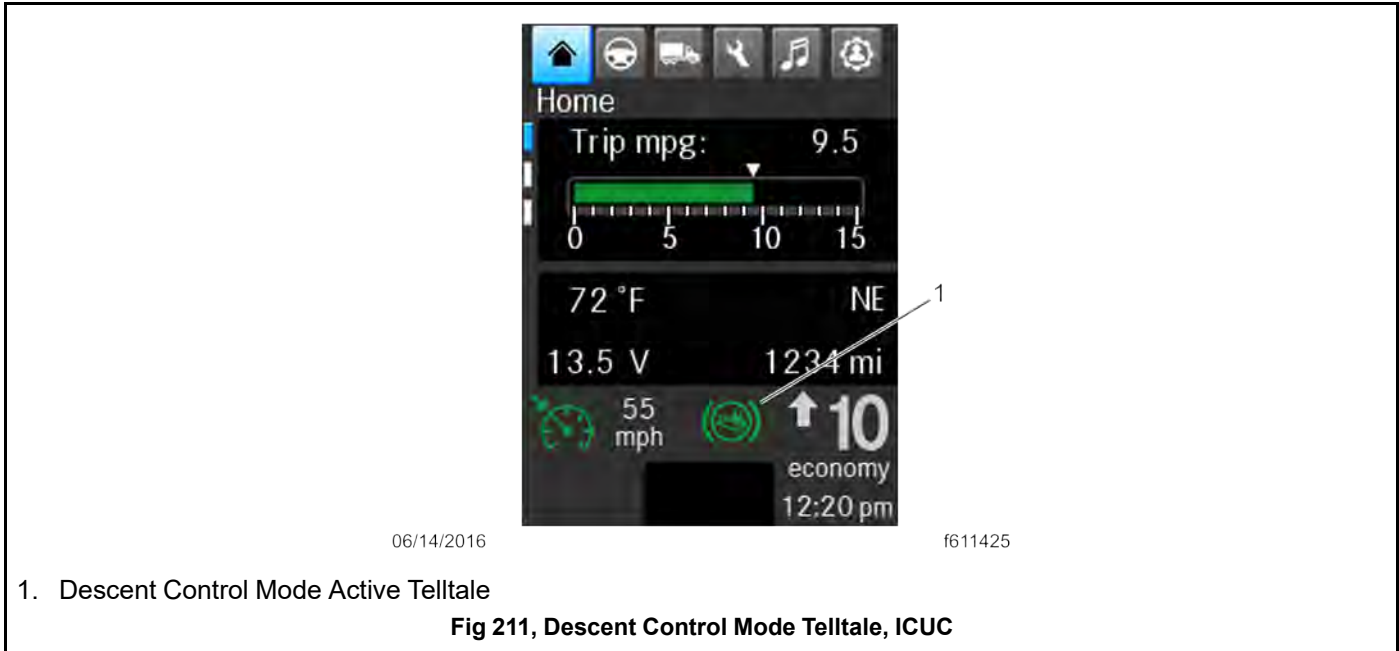

In descent control mode, all three levels of engine braking will be employed to keep the speed below the set speed regardless of the level selected by the right-hand stalk switch.

In the case of very steep road grades, the engine brake may not be able to maintain the vehicle speed. The driver may apply the service brakes without dropping out of descent mode to slow the vehicle. If the vehicle is slowed below the set speed, this lower speed will become the set speed after the driver releases the service brakes. In this instance, a pop-up window in the ICU will notify the driver a new set speed was captured as shown in Fig. 183, [Descent Mode Speed Set Notification, ICUC](#).

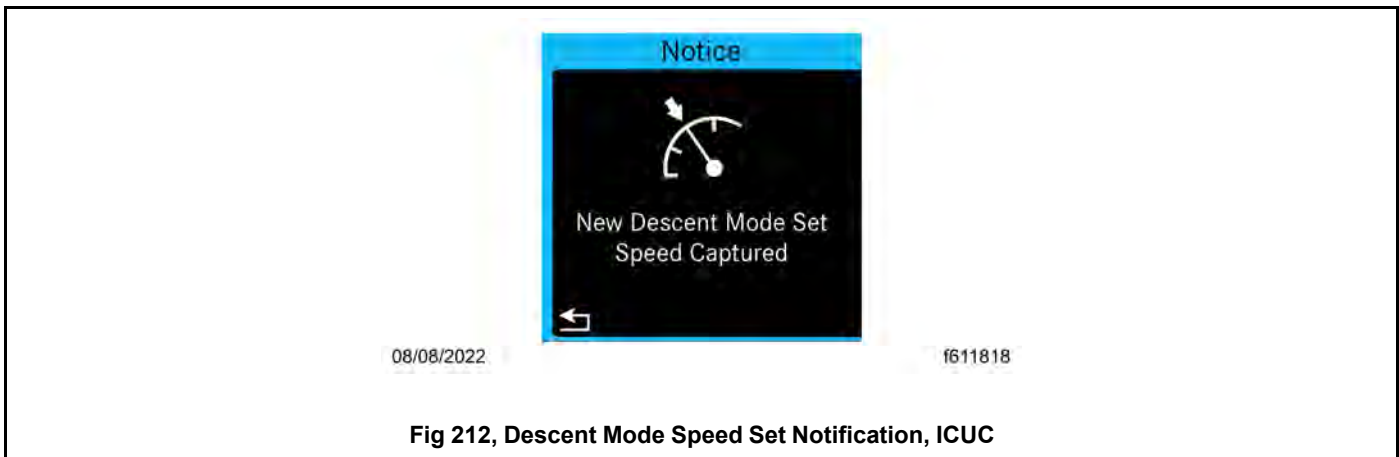

Descent control mode will not keep the speed above the lower limit of the set speed, so it is possible to eventually coast to a stop, unless the stalk lever is moved to 'off' (position 0), or the accelerator pedal is applied.

After accelerator pedal application, descent control mode is resumed.

Moving the lever to the 0 position deactivates descent control mode and resumes cruise control, using the descent control set speed as the cruise control set speed.

8.02.03 Deceleration Mode

Deceleration mode reduces the vehicle speed at a constant rate.

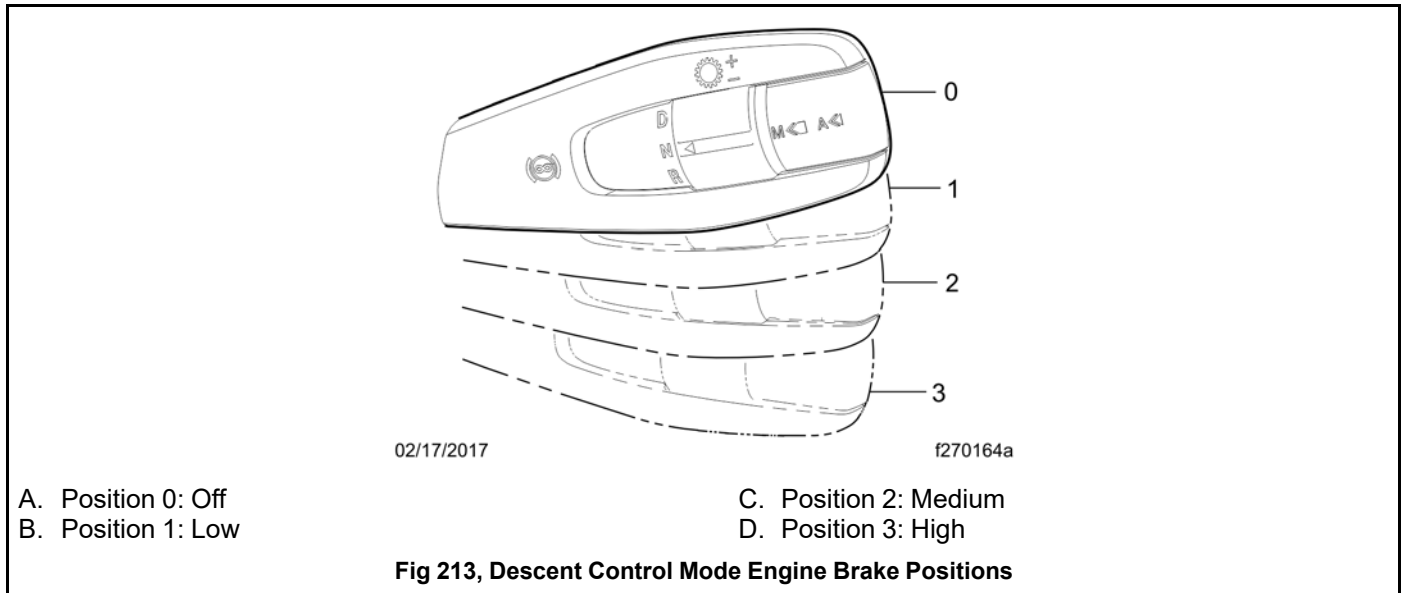

While in cruise control, activate deceleration mode by turning on the engine brake (Fig. 184, [Descent Control Mode Engine Brake Positions](#), lever position 1, 2, or 3). The vehicle will decelerate at a constant rate until the vehicle comes to a stop, unless the accelerator pedal is applied to override the deceleration, or the right-hand stalk switch is moved to 'off' (position 0).

Moving the lever to position 0 resumes the previously set cruise control speed.

8.03 Hill Start Aid

The hill start aid (HSA) feature prevents the vehicle from rolling on a slope steeper than three percent to allow for a controlled launch.

HSA prevents a stationary vehicle in forward gear from rolling downhill prior to continuing to drive up the hill; HSA also prevents a stationary vehicle in reverse gear from rolling downhill prior to continuing to back up the hill.

HSA delays the release of service brakes until enough torque is available to begin moving the vehicle, up to a maximum of three seconds. If sufficient driveline torque is not detected after three seconds, the system audibly alerts the driver and releases the brakes.

HSA is on by default. It can be turned off by pressing the HSA OFF dash switch shown in Fig. 185, [Hill Start Aid Off Dash Switch](#).



When hill start aid is inactive, the HSA OFF telltale, shown in Fig.186, [Hill Start Aid Disengaged Telltale](#). flashes on the driver display screen.



To turn hill start aid on again, press the HSA OFF switch or cycle the vehicle keyswitch.

If the hill start aid disengaged telltale appears as a solid image on the driver display screen, there is a fault in the system.

8.04 Brake Hold

The brake hold function eases the strain of driving in stop-and-go traffic by allowing the driver to "hold" the brake without constantly applying pressure to the brake pedal. The brake hold function is an extension of hill start aid (HSA).

To activate the brake hold function, bring the vehicle to a complete stop, then press the brake pedal further toward the floor. The HOLD telltale, shown in Fig.187, [Brake Hold Active Telltale](#). illuminates on the driver display to indicate the function is active and the vehicle's brake lights come on. The driver can then take their foot off the brake pedal without releasing the service brakes.

If the brake pedal is pressed down farther, air is added to the chamber, continuing the brake hold.



To release the brake hold, press the accelerator pedal, engage the park brake, or rapidly apply and release the brake pedal.

The hold function is deactivated when the HSA OFF switch is pressed to disable HSA.

The hold function cannot be engaged if any of the following are true:

- the anti-lock braking system was active in bringing the vehicle to a stop,
- the anti-lock braking system is in a fault state, or
- the vehicle is in reverse gear.

If the hold function is active for four minutes, the window shown in Fig.188, [Engage Park Brake Message](#). appears on the ICU warning the driver to engage the park brake. An audible alarm activates at the same time and repeats every minute until the park brake is set.

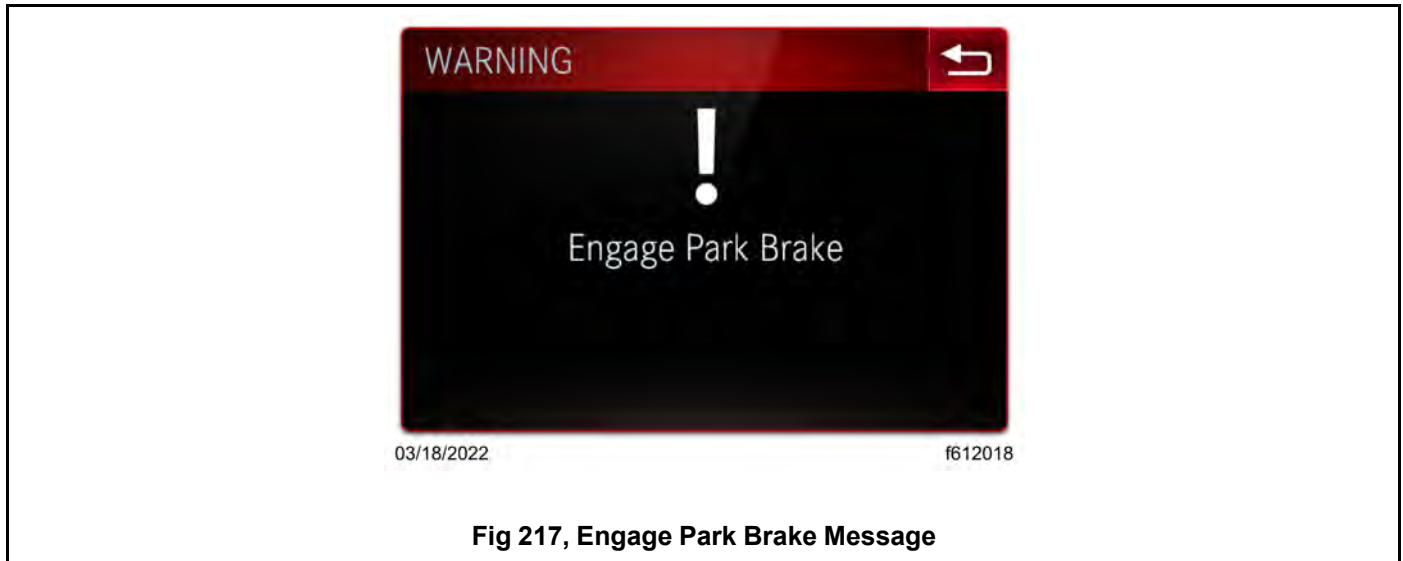

The same warnings are triggered if the hold function is active and:

- the ignition is turned off without the park brake being set, or
- the brakes are not strong enough to hold the vehicle in place and it starts rolling.

If a door is opened without the park brake being set when the hold function is active, the horn sounds and a visual warning activates on the driver display. If the seat occupancy sensor registers an empty seat under the same conditions, the same warnings are triggered. Warnings cease when the condition that triggered the warning is corrected.

8.05 Intelligent Powertrain Management (IPM)

NOTE: IPM is standard with a DT12 transmission; IPM is not available with an Eaton or Allison transmission.

IPM is an optional fuel savings application that functions as a predictive cruise control. Using 3D digital map technology and GPS, IPM evaluates the upcoming road grade about a mile in advance to determine the best use case for most fuel-efficient vehicle speed and gear selection.

The IPM active telltale illuminates on the driver display when an IPM mode is activate. See Fig. 189, [IPM Active Telltale, ICUC](#).

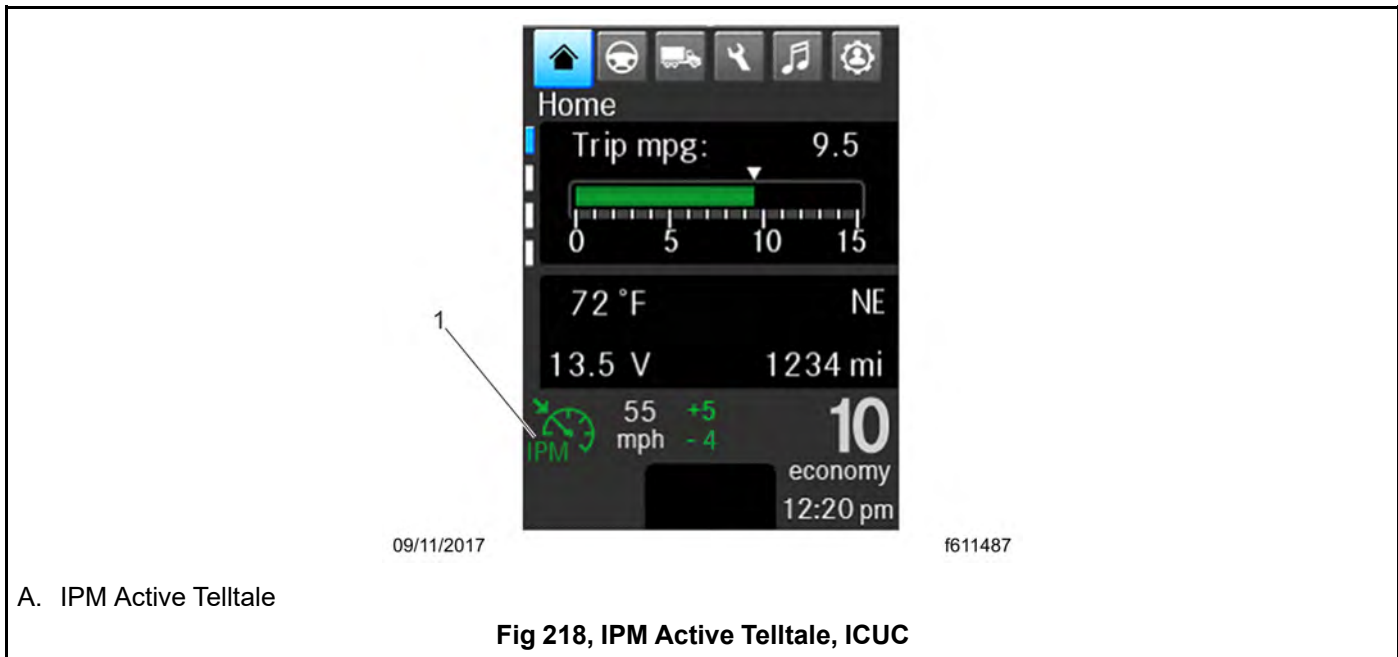

The 3D digital map database contains profile information for over 200,000 highway miles (322,000 km) in the 48 contiguous United States, the Trans-Canada Highway, and most major Canadian highways.

Using these maps, IPM will vary the cruise speed, depending on the approaching road grade.

For a vehicle equipped with the Economy Package, the default variance is +5/4 mph (+8/6 km/h). If the engine brake is enabled, IPM may automatically engage the engine brake at speeds higher than the cruise set speed.

Key predictive features of IPM are:

- Steep Mountain Mode applies if the vehicle will not maintain cruise set speed while climbing. To balance travel time while saving fuel, the vehicle will first predictively accelerate before starting the climb, and may slow down as it approaches the crest of the hill. In this scenario the speed is allowed to fall below the cruise control underspeed.
- Crest Coasting reduces speed before cresting a hill
- Dip Coasting increases speed before a dip
- Predictive Shifting selects a gear shifting strategy for upcoming terrain
- Load Balancing maintains most efficient power for near zero road grades; small fluctuation in road speed may be seen from cruise set speed by ± 1 or 2 mph
- Predictive Adaptive Cruise Control if equipped with adaptive cruise control (ACC), allows IPM to increase following distance

IPM behavior is different from that of conventional cruise control. The system incorporates features to improve the overall driver experience. Some key points to remember are:

- IPM is active only when cruise control is engaged.
- IPM only controls speed within the upper and lower bounds of the cruise set speed. The upper and lower set limits may be exceeded up to 2 mph (3 km/h) for a limited time during dip coasts, as IPM predicts the terrain demands for the most fuel-efficient performance. The driver is responsible for setting a speed appropriate for the conditions and grade. If equipped, IPM upper and lower bounds can be adjusted by selecting the quick access button on the steering wheel.
- IPM can engage eCoast sooner, later, or not at all compared to conventional cruise control.
- IPM may automatically engage the engine brake at a higher speed than the cruise set speed.
- If IPM becomes unavailable, conventional cruise control can still function.

**WARNING:**

Apply the brakes and downshift as necessary when driving on downhill grades. IPM does not adequately control vehicle speed on steep downhill grades. Failure to use normal braking techniques when IPM is active could result in personal injury and vehicle damage.

IMPORTANT: IPM adjusts the vehicle set speed to achieve maximum fuel economy, but it does not account for traffic flows or surrounding vehicles.

For best fuel-savings, use cruise control whenever possible. Driver interaction with IPM is the same as conventional cruise control, using the standard cruise control buttons. In the event of a problem with IPM, or when driving on a road with no profile information available, the system reverts to conventional cruise control.

Using the accelerator pedal will cancel the current IPM session. Disengaging the cruise control will also deactivate IPM.

8.06 PasSmart

A standard feature on fleet vehicles, PasSmart enables a vehicle to exceed a set speed limit by a limited amount to allow for passing vehicles on the highway. For example, a PasSmart vehicle may be programmed to enable the vehicle to travel 5mph over a set speed limit for 30 minutes every 24 hours. This speed limiting increases overall fuel economy.

If equipped, the PasSmart function is initiated by double-pumping the accelerator pedal within a two second period. When initiated, the PasSmart window as shown in Fig. 190, [PasSmart Active, ICUC](#) appears. The PasSmart timer shown in this window starts when the road speed limit is exceeded by 1.89 mph (3 km/h).

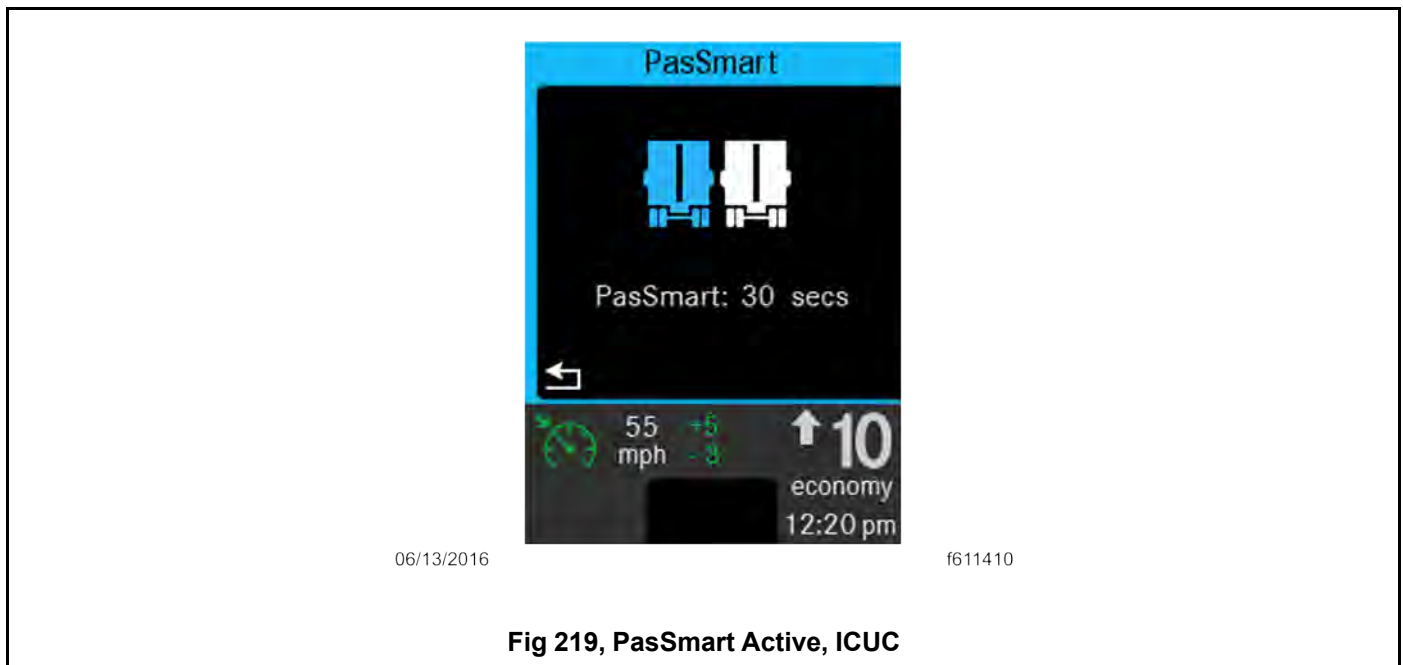

Fig 219, PasSmart Active, ICUC

PasSmart does not disengage cruise control. After engagement, PasSmart deactivates when the speed limit of the vehicle drops below the cruise control standard set speed limit at which point cruise control resumes.

Thirty seconds before a daily PasSmart limit is reached, the PasSmart active window, if closed, opens to notify the driver of the time remaining.

8.07 Electronic Stability Control (ESC)



WARNING:

ESC is intended only as an aid for a conscientious and alert driver. Carefully read the information in this manual to understand this system and its limitations. ESC is not a substitute for safe driving procedures. Failure to drive safely, and use the system properly, could result in personal injury and/or death and property damage.



CAUTION:

Changing or modifying the location of the ESC sensor or reconfiguring the vehicle, such as by changing the wheel-base or adding axles, can change the performance of the enhanced stability control system and may result in product or property damage and personal injury.

Electronic stability control (ESC) works by constantly comparing the driver's intention with the vehicle's actual behavior. The system does this by monitoring wheel speed, steering angle, yaw rate, lateral acceleration, throttle position, and brake application. A central microcomputer analyzes the collected data and triggers a response to keep the vehicle on course when an unstable condition is detected.

When the system detects that the vehicle is at risk of over-steering or under-steering, it applies individual tractor wheel end brakes and trailer brakes and/or cuts power to reduce the likelihood of a drift-out or jackknife.

If the acceleration sensor detects the vehicle is at risk of rolling over, the roll stability control system within the ESC automatically reduces power and applies the brakes.

Yaw control is not active below approximately 6 mph (10 km/h). Roll stability control is not active below approximately 12 mph (20 km/h). At higher speeds, ESC operates automatically; the driver does not monitor or activate the system.

The driver has full control over the vehicle until the system detects a potential risk and intervenes accordingly.

The ESC telltale, as shown in Fig.191, [Electronic Stability Control \(ESC\) Telltale](#), appears on the driver display when ESC intervenes and when ESC is unavailable due to a fault. The ESC telltale flashes when an ESC event is actively occurring and is solidly illuminated when ESC is unavailable due to a fault.



It is normal for the ESC telltale to illuminate shortly after a curve, lane change, or other driving maneuver that results in ESC detecting a rollover-risk.

8.08 SafetyDirect® by Bendix

8.08.01 Bendix Forward Facing Camera



WARNING:

SafetyDirect by Bendix is solely intended as a support for a conscientious professional driver.

IMPORTANT: In order for the forward facing camera to operate properly, the windshield area in front of the camera must be clean, unobstructed, and not be damaged in any way.

SafetyDirect by Bendix is a fleet management system that automatically records ten to twenty seconds of video during a safety event and delivers it and other vehicle safety data wirelessly and in real time to the Bendix SafetyDirect portal.

If equipped, the SafetyDirect system uses the telematics systems of the vehicle and a Bendix 5G forward facing video camera, shown in Fig. 192, [Multipurpose Camera 2 and Bendix Camera Brackets](#). The Bendix camera records in color and can capture high-quality video in low light conditions.



1. Multipurpose 2 Camera Bracket

2. Bendix Forward Facing Camera Bracket

Fig 221, Multipurpose Camera 2 and Bendix Camera Brackets

8.08.02 Driver Facing Camera

If equipped with a driver facing camera, the SafetyDirect system also records ten to twenty seconds of driver behavior during an event.

8.08.03 The Bendix SafetyDirect Portal



WARNING:

SafetyDirect by Bendix is solely intended as a support for a conscientious professional driver.

IMPORTANT: In order for the forward facing camera to operate properly, the windshield area in front of the camera must be clean, unobstructed, and not be damaged in any way.

SafetyDirect by Bendix is a fleet management system that automatically records ten to twenty seconds of video during a safety event and delivers it and other vehicle safety data wirelessly and in real time to the Bendix SafetyDirect portal.

If the vehicle is equipped with the SafetyDirect system, data is sent from the vehicle's safety systems to the portal. The portal presents each driver's behavior in a 'miles between events' format with the following events recognized:

- lane departure warning
- excessive lane departure warning
- lane change without turn signal
- loss of video tracking
- lane departure warning system disabled
- distance/tailgate alert given
- forward collision warning
- collision mitigation braking
- automatic traction control (ATC) activation
- antilock braking system (ABS) activation
- stability system activation
- excessive braking
- excessive speed on curves
- average following distance
- adaptive cruise control usage

8.09 Lytx SF500 DriveCam System

8.09.01 Driver Facing Camera

**WARNING:**

The Lytx DriveCam event recorder is a driver aid only. It is not a substitute for a safe, conscientious driver. It cannot compensate for a driver that is distracted, inattentive, or impaired by fatigue, drugs, or alcohol. Whether or not the Lytx DriveCam event recorder is in use, it is always the responsibility of the driver to take appropriate corrective action. Never wait for the Lytx DriveCam event recorder to provide a warning or audible alert before taking measures to avoid an accident. Failure to do so can result in severe property damage, serious personal injury or death.

The Lytx SF500 DriveCam System constantly monitors driving behaviors. When risky driving behavior is detected it begins a recording, indicated by a red light in the camera. An audible alert sounds to alert the driver. The alerts can not be muted and continue to occur until the driver corrects the behavior.

Risky driving behaviors that may be monitored include:

- Driver Smoking
- Food or Drink
- Handheld Device
- Inattentive or Distracted Driver
- No Seat Belt
- Speed (company policy)
- Speed (posted speed)

- Following Distance
- Lane Departure

Vehicles equipped with a Lytx SF500 driver facing camera have a switch on the dash as shown in Fig. 193, [Lytx Video Record Switch](#). Press the VIDEO REC switch to manually initiate a ten-second recording. An amber lamp in the switch illuminates while the recording is in process.

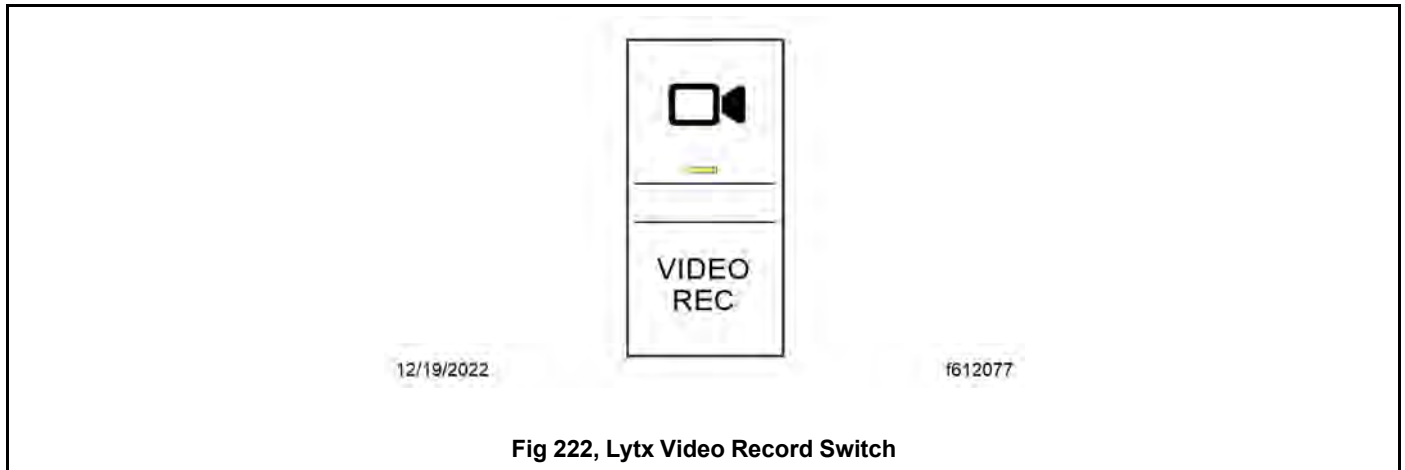

The Lytx SF500 DriveCam System automatically turns on a privacy mode when the parking brake is set. When the vehicle is on, it is indicated by a solid blue LED light on the Lytx camera. This mode cannot be initiated by the driver.

Videos can be viewed on the Lytx account system which requires approval to access.

For more information, access the Lytx SF500 DriveCam System User's Manual by scanning the Lytx QR code shown in Fig. 194, [Lytx QR Code Link to Manual](#).



9.01 System Overview 204

9.02 Power Distribution 207

 9.02.01 Power Distribution..... 207

 9.02.02 Cab Electrical and Electronic Components..... 209

9.03 Cab Load Disconnect Switch..... 209

9.04 Smart Battery Shut-Off Switch..... 210

9.05 Emergency Power Mode..... 211

9.06 Powernet Management..... 212

9. Electrical System

9.01 System Overview

Power is supplied by the vehicle power distribution modules (PDMs) to electronic control units (ECUs). The ECUs coordinate power to outputs such as lighting, displays, gauges, and indicators and control power distribution by monitoring inputs such as sensors and switches. The ECUs also continuously monitor the status of all input devices and transmit messages over multiple control area networks (CANs), reducing the number of sensors required for operation.

The Instrumentation Control Unit (ICU) and Fault Codes

The majority of electrical and electronic issues on the vehicle will have an associated fault code, which will be displayed on the ICU. If the ICU receives active fault codes during the ICU self-check, it displays them one after the other until the parking brake is released or the ignition is turned off. Once the parking brake is completely released, the ICU displays alerts until acknowledged. See Fig. 195, [ICUC Active Faults Alert Screen](#). If there are no active faults, the ICU displays the home screen after the self-check completes.

NOTE: Some non-critical faults may be suppressed and will not appear during an instrumentation control unit (ICU) self-check.



Fig 224, ICUC Active Faults Alert Screen

When there is an active vehicle fault code, a popup will appear on the ICU message screen.

To access fault codes in the ICU:

1. Use the buttons on the left-hand steering wheel to navigate to the wrench icon and press OK.
2. ECUs with active faults will have an exclamation point next to them. Use the down arrow to select the affected ECU from the list, then press OK

Refer to the ECU acronyms list for the full names of acronyms on the ICU screen. See Table.25, [ICU Electronic Control Unit Acronyms](#).

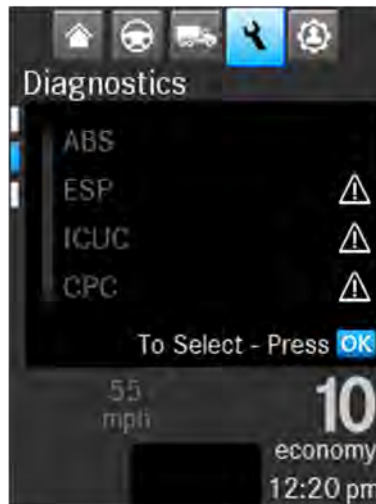

08/25/2016

f611439

Fig 225, Electronic Control Unit (ECU) List in the ICUC

3. Locate the code to troubleshoot from the list of active fault codes, then press OK to access the information screen. See Fig.197, [Information Screen for an Active Fault Code](#).

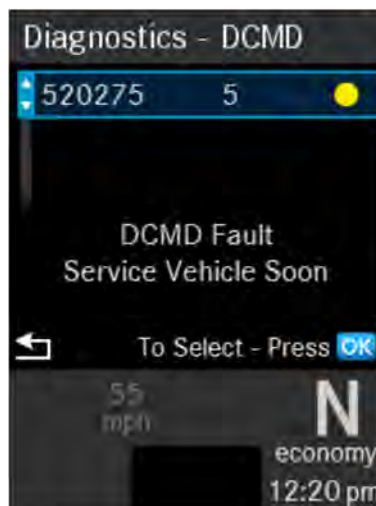

08/26/2016

f611442a

Fig 226, Information Screen for an Active Fault Code

4. Press OK again to access additional information. See Fig.198, [Additional Information for the Fault](#).

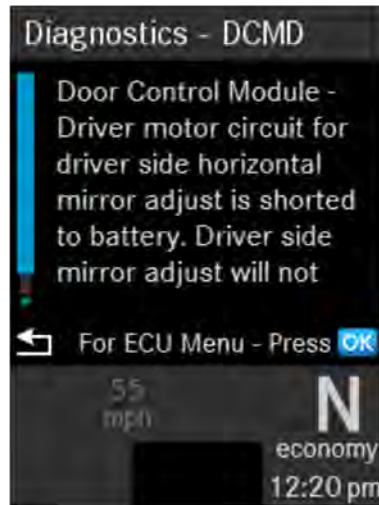

08/26/2016

f611443

Fig 227, Additional Information for the Fault

ICU Electronic Control Unit Acronyms			
ABS	Antilock Brake System	ICU	Instrumentation Control Unit
ACM	Aftertreatment Control Module	MCM	Motor Control Module
CGW	Central Gateway	RDF	Radar Front End
CPC	Common Powertrain Controller	SAS	Steering Angle Sensor
DCMD	Door Control Module, Driver	SSAM	Single Signal Detect and Actuation Module
DCMP	Door Control Module, Passenger	TCM	Transmission Control Module
HVCF	Heating/Ventilation/AC Front (HVAC)	TPMS	Tire Pressure Monitoring System
HVCP	Heating/Ventilation/AC, Auxiliary (HVAC)	VRDU	Video Radar Decision Unit

To troubleshoot and resolve fault codes, take the vehicle to an authorized Freightliner service center for diagnostics.

9.02 Power Distribution

9.02.01 Power Distribution

The vehicle power distribution system provides battery power to the electrical and electronic systems.

The following components make up the vehicle power distribution system:

- Battery Cable Access (BCA)
- Vehicle Power Distribution Module (VPDM)
- Optional Cab Load Disconnect Switch (CLDS)

Vehicle power is supplied by the batteries to the battery cable access (BCA) box. The BCA front wall pass-through is the primary interface through which battery power gets transferred from outside the cab to the inside. It is located on the passenger side of the engine compartment front wall. This provides a disconnect point for harness service, testing, and replacement. See Fig.199, [BCA](#).

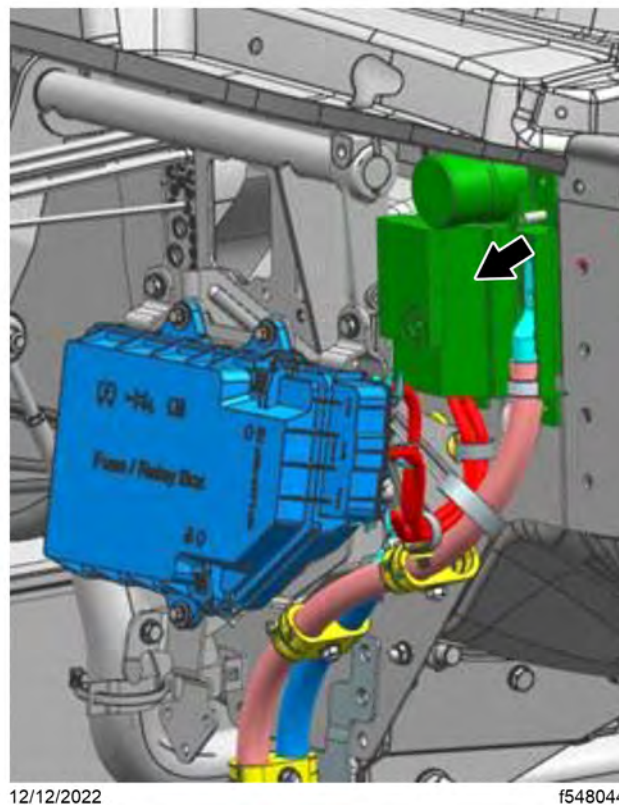

Fig 228, BCA

The power supplied by the batteries goes to the vehicle power distribution modules and the Single System and Actuation Module (sSAM).

The PDMs are fuse power distribution boxes. They provide power and circuit protection for powertrain needs, cab functions, and various stand alone modules. They also supply power to the emergency power supply circuits in the event of a module failure. The PDMe is located in the engine compartment on the frontwall. See Fig.

200, [Power Distribution Module \(PDMe\) in Engine Compartment](#) The PDMi is located in the vehicle electronics bay, behind the passenger-side dash panel. See Fig.201, [Power Distribution Module \(PDMi\) Behind Right-Side Dash](#)



Fig 229, Power Distribution Module (PDMe) in Engine Compartment



Fig 230, Power Distribution Module (PDMi) Behind Right-Side Dash

Depending on a vehicle's specifications, the fuses and relays installed and their locations can vary. Each PDM inside cover has a fuse map with an image of the fuse layout for that vehicle.

9.02.02 Cab Electrical and Electronic Components

Advanced Signal Detect and Actuation Module (ASAM)

The advanced signal detect and actuation module (ASAM) is the primary module in the electrical system, combining chassis power distribution, cab power distribution, and modular switch functions into a single ECU. The ASAM does **not** contain fuses or relays.

The ASAM reads input information from sensors, switches, and databus messages, and drives output and controller area network (CAN) messages. The ASAM is located behind the right side dash panel. See Fig. 202, [Component Locations Behind the Dash](#).

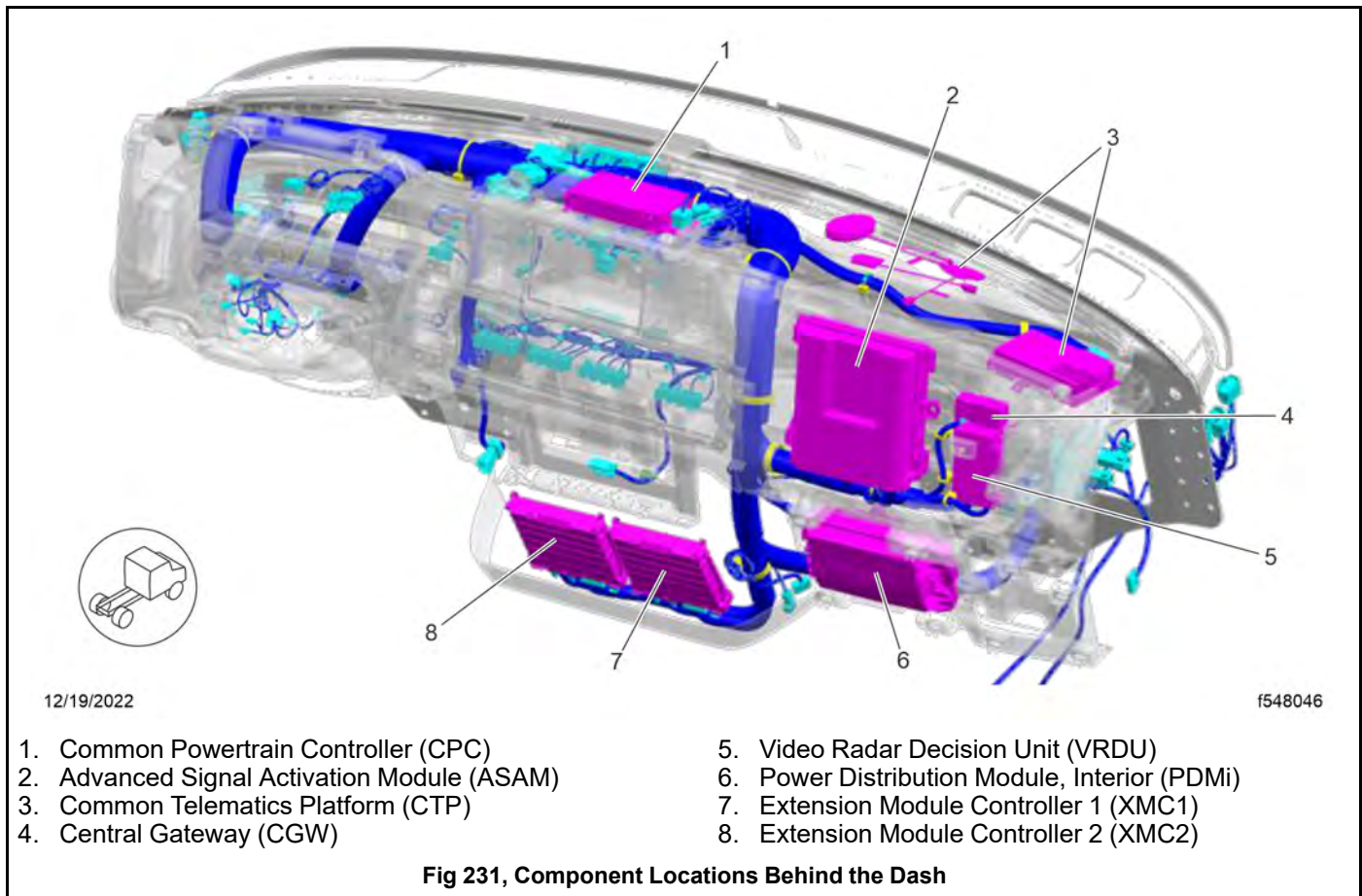

9.03 Cab Load Disconnect Switch

**WARNING:**

Turning the cab load disconnect switch (CLDS) to the off position does not disconnect power to all electrical components (e.g. the starter and sSAM). To work on the vehicle safely, the negative leads must be disconnected from the battery.

The cab load disconnect switch can be used to disconnect the circuits between the battery and the battery cable access box (BCA), minimizing the power draw on the battery when the vehicle is parked for an extended period of time.

The CLDS may be mounted in a variety of location, including:

- inside the cab on the outboard side of the driver's seat;
- behind the cab on the driver's side;
- at the battery box.
- outside of the cab.

The ignition must be turned OFF before turning the cab load disconnect switch ON or OFF.

The CLDS is set to ON for normal daily use. When the CLDS is set to ON, a steady red LED indicator at the base of the switch selector illuminates. See Fig.203, [Cab Load Disconnect Switch](#).

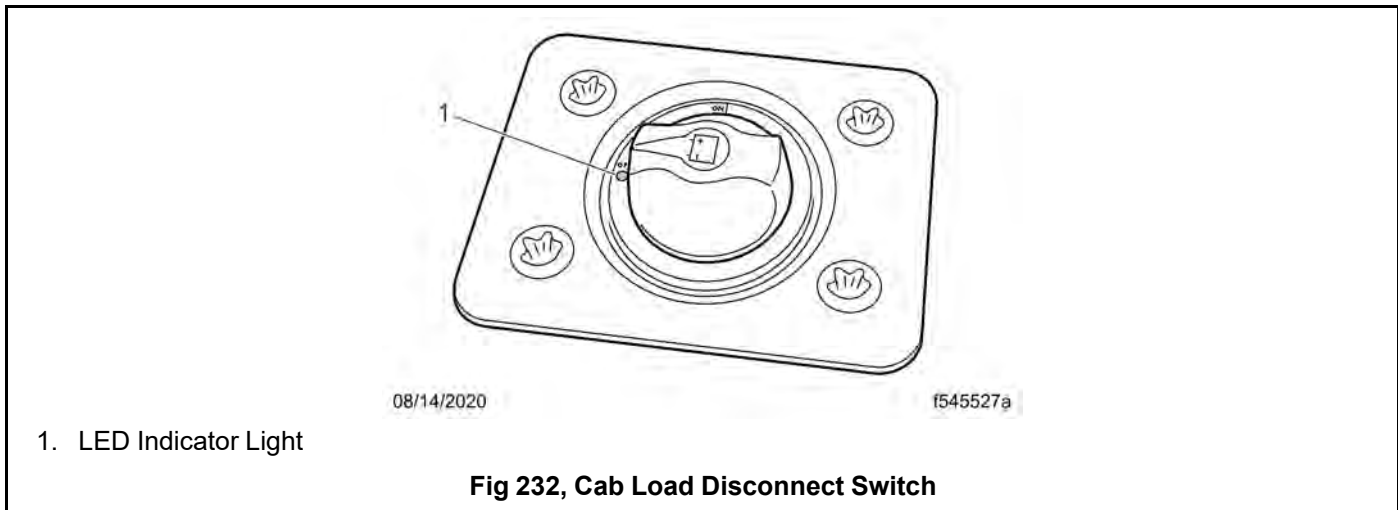

A flashing red LED indicates an error with the CLDS. Take the vehicle to an authorized Freightliner service center for diagnostics.

The CLDS should be set to OFF if the vehicle will be parked for more than two days. However, even with the CLDS OFF, the vehicle still draws a small amount of battery power. If parking the vehicle for more than five days, disconnect the batteries.

IMPORTANT: If the vehicle is driven while the CLDS is set to the OFF position, the vehicle will run on the emergency power feed but the batteries will not be charging. The **Emergency Power Mode** will activate.

9.04 Smart Battery Shut-Off Switch

IMPORTANT: The keyswitch should be in the OFF position before turning the smart battery shut-off switch on or off.

The smart battery shut-off switch is a red switch located inside the cab on the outboard side of the driver's seat. See Fig.204, [Smart Battery Shutoff Switch](#).



Fig 233, Smart Battery Shutoff Switch

A vehicle in daily use has the smart battery shut-off switch turned on, indicated by a red LED in the switch.

Turning the smart battery shut-off switch off minimizes the power draw on the battery, preserving battery life and the ability of the vehicle to start after being parked for a number of days. Set the smart battery shut-off switch to OFF if the vehicle is going to be parked for more than two days.

To avoid accidental activation, the smart battery shut-off switch must be pressed and held for two seconds when turning it on or off.

9.05 Emergency Power Mode



WARNING:

If emergency power mode activates, do not shut down the engine until the vehicle is out of traffic and in a safe place. The engine will not be able to be restarted until the cause of the loss of power is corrected.

The emergency power circuit allows a vehicle to be moved out of traffic and off the road in the event of a loss of power.

The emergency power circuit is live even when the cab load disconnect switch, or the smart battery shut-off switch, is turned off.

The following is a list of behaviors that could occur when in emergency power mode:

- Inoperative switches and lamps.
- Unresponsive or frozen gauges.
- Display of warning lamps that indicate low voltage and/or ECU faults.
- Lamps either constantly on or flashing.
- Windshield wipers on low speed.

The cause of the loss of power dictates the specific behaviors that appear. If emergency power mode is activated due to a microprocessor failure in the sSAM ECU, the gauges become unresponsive; this includes dash panel lamps and turn signal indicators.

NOTE: Possible variations in lamp illumination are noted in parentheses.

In emergency power mode with the ignition in the ON position the following lamps stay on constantly:

- dash panel lamps including turn-signal indicators (except in case of microprocessor failure in the sSAM ECU.)
- headlamp, low beams (left, right, or both sides)
- headlamp, accent lamps, left and right (in the case of a BCA fault)
- rear stop lamp (left, or both sides)

In emergency power mode with the ignition in the ON position the following lamps flash:

- headlamp turn signals, both sides
- trailer tail lamps, both sides
- outboard clearance lamps, both sides
- tractor tail lamps (right, left, or both sides)
- side marker lamps, forward (right, left, or both sides)
- identification lamps (all or none)

Turning the ignition switch to OFF when in emergency power mode shuts down the exterior lighting, windshield wipers, and the engine. The engine will not start if the ignition switch is turned back to the ON position.

9.06 Powernet Management

The powernet management feature protects the batteries from excessive discharge by disconnecting certain loads—features that draw power—from the battery power supply. This allows the batteries to maintain enough of a charge to restart the vehicle.

Features that draw power are prioritized into different categories:

1. House loads: This includes the majority of dash and sleeper power outlets, sleeper reading and spot lamps, and sleeper auxiliary fans.
2. Basic loads: This includes power for fleet management systems and third party telematics as well as critical dash and sleeper power outlets.

By making noncritical features that draw power temporarily unavailable, powernet management allows the driver to continue using critical features.

Progressive low voltage disconnect (PLVD) is used to implement the powernet management feature.

PLVD calculates disconnecting loads based on battery voltage, ignition switch status, and engine rpm. When battery voltage drops below a predetermined value, house loads are turned off. One minute before house loads are turned off, a pop-up message will display in the ICU and an audible alarm will sound.

The front reading lamp, spot lamp, and sleeper lamps—designated as house loads—can be turned back on after being shutdown by PLVD by pressing on the light or light switch.

No alarm sounds before basic loads are turned off.

A time delay is implemented for the shutdown and reactivation of loads to avoid unnecessary cycling when battery voltage is close to shutdown thresholds.

Loads disconnected by the PLVD will reconnect when all of the following conditions are met:

- ignition ON;
- engine at 450 rpm or above;

- batteries reach and maintain 12.7 volts for one minute.

10.01 Engine Starting 216

 10.01.01 Engine Starting 216

 10.01.02 Cold-Weather Starting 217

 10.01.03 Starting After Extended Shutdown 217

10.02 Engine Operation 218

 10.02.01 Safety and Environmental Considerations 218

 10.02.02 Engine Break-In 219

 10.02.03 Normal Operation 219

 10.02.04 Cold-Weather Operation 219

 10.02.05 High-Altitude Operation 220

10.03 Engine Shutdown 220

10.04 Engine Protection—Warning and Shutdown 220

10. Engine Starting, Operation, and Shutdown

10.01 Engine Starting

10.01.01 Engine Starting

This engine chapter is to serve as a guide for best practices only. Each engine model may have operating characteristics that are unique to that particular engine, and will be documented in the engine manufacturer's literature. Always see specific instructions and recommendations from the engine manufacturer.

NOTE: Before starting the engine, see [Instruments](#) and [5.01 Ignition Switch and Key](#), see [5.01 Ignition Switch and Key](#). Read the engine manufacturer's operating instructions before starting the engine.

**WARNING:**

Never pour fuel or other flammable liquid into the air inlet opening in the air intake in an attempt to start the vehicle. This could result in a flash fire causing serious personal injury or property damage.

IMPORTANT: Freightliner vehicles are equipped with starter interlocks to enhance reliability and safety. Anti-grinding, starter pinion, and thermal protection logic limit the amount of time and conditions for starter engagement. Cranking may be limited from 5 to 15 seconds, with a 30-second cool-down period, as determined by the protection logic. If the engine is turning, the starter will not engage. Depending on the transmission option, the starter will not engage if the clutch is not fully depressed, or if the transmission is not in neutral.

IMPORTANT: The starter **can not** be used for priming the fuel system. If the fuel/water separator filter is replaced, and the fuel system needs to be primed, see the engine manufacturer's operating instructions.

1. Before engine start-up, complete the pre- and post-trip inspections and maintenance procedures, see [23.01 Safety Precautions](#).
2. Set the parking brake.
3. Place the transmission in neutral. On vehicles with manual transmissions, fully depress the clutch pedal.

NOTE: Depending on local jurisdictional emissions regulations, vehicles and/or engines that are domiciled outside of the U.S. and Canada may not be equipped with the 'STARTER BLOCKED' function.

4. Turn the ignition switch to the ON position and allow the self-check to complete.

NOTE: The driver display screen may present 'STARTER BLOCKED' message if the start-up sequence is not completed, the transmission is in gear, or the starter has overheated.

5. Once the start-up sequence has completed, turn the ignition key to the START position. Release the key the moment the engine starts.

If the vehicle is equipped with an engine start switch, shown in Fig.205, [Engine Start Switch](#), hold the switch down while turning the ignition key to the START position. Release the switch and the key the moment the engine starts.

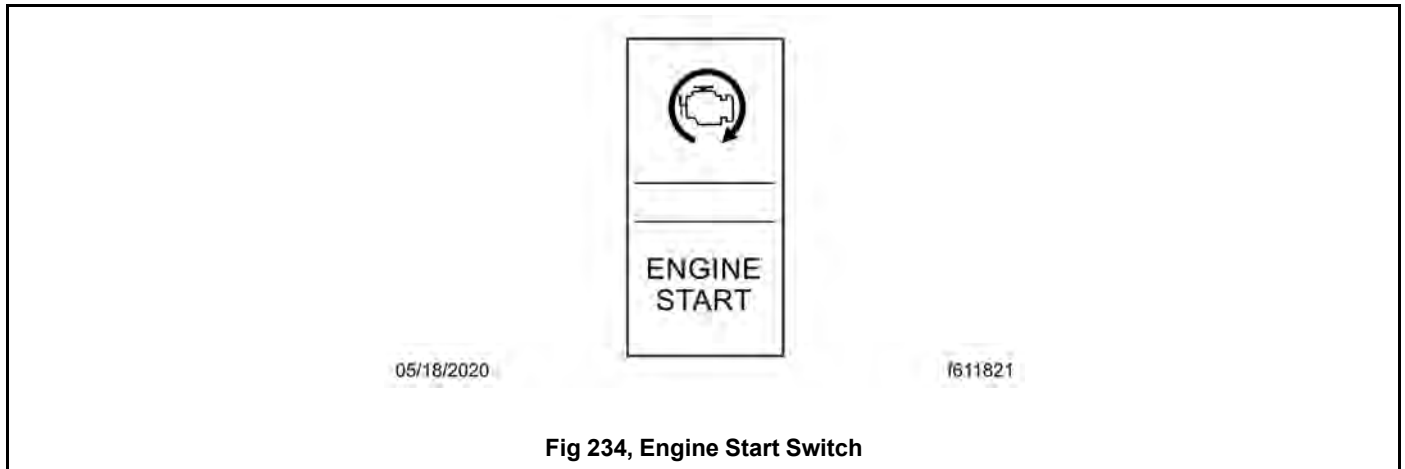

Fig 234, Engine Start Switch

**NOTICE:**

Do not rev the engine if the oil pressure gauge indicates no oil pressure. Shut down the engine if oil pressure does not build within approximately ten seconds. Check to determine the cause of the problem. Operating the engine with no oil pressure will damage the engine.

6. It is not necessary to idle the engine before engaging or starting the operation, but load should be applied gradually during the warm-up period until the oil temperature reaches 140°F (60°C).
7. Apply load gradually during the warm-up period.

**NOTICE:**

If the oil pressure gauge indicates no oil pressure, shut down the engine within approximately ten seconds to avoid engine damage.

8. Check the oil pressure gauge for any drop in lubricating oil pressure or mechanical malfunction in the lubricating oil system. Minimum oil pressure at idle is 7 psi (50 kPa).

10.01.02 Cold-Weather Starting

See the engine manufacturer's operation manual for starting aids that are approved for specific engines.

10.01.03 Starting After Extended Shutdown

Before engine start-up, complete the engine pretrip inspections, see .

**NOTICE:**

Failure to eliminate water-diluted lubricating oil may lead to serious engine damage at startup.

An engine in storage for an extended period of time (over winter, for example) may accumulate water in the oil pan through normal condensation of moisture on the internal surfaces of the engine. Oil diluted by water cannot provide adequate bearing protection at start-up. For this reason, change the engine oil and filters after extended storage.

10.02 Engine Operation

10.02.01 Safety and Environmental Considerations

**WARNING:**

Do not operate the engine in an area where flammable vapors such as gasoline or diesel fumes are present. Shut off the engine when in an area where flammable liquids or gases are being handled. Failure to observe these precautions could result in serious injury or death.

All engines on Freightliner vehicles comply with the requirements of the Federal (U.S.) Clean Air Act. Once an engine is placed in service, the responsibility for meeting both state and local regulations is with the owner/operator.

IMPORTANT: Depending upon local jurisdictional emissions guidelines, vehicles that are domiciled outside of the U.S. and Canada may not have engines and/or emissions aftertreatment systems that are compliant with current regulations.

**NOTICE:**

It is extremely important that the following guidelines be followed for engines that comply with EPA07 or newer regulations, or damage may occur to the aftertreatment device, and the warranty may be compromised.

Use ultralow-sulfur diesel with 15 ppm sulfur content or less.

Do not use fuel blended with used engine lube oil or kerosene.

Use only approved engine lube oil. For lists of engine oils approved for Detroit Diesel engines, refer to the Engine Operator Manual, accessible on Lubricants, Fuels & Coolants on the DTNA Portal. For third party engines, please refer to the engine manual.

A Top Tier™ compliant fuel is recommended. Look for the symbol that denotes a Top Tier compliant fuel; see Fig. 206, [Top Tier Fuel Symbol](#).



04/27/2017

f470698

Fig 235, Top Tier Fuel Symbol

Adequate maintenance of the engine and the diesel particulate filter (DPF) are the responsibility of the owner/operator, and are essential to keep the emission levels low. Good operating practices, regular maintenance, and correct adjustments are factors that will help keep emissions within the regulations.

10.02.02 Engine Break-In

Each engine must pass a full-load operating test on a dynamometer before shipment, thereby eliminating the need for a break-in. Before running the engine for the first time, follow the instructions in the manufacturer's engine operation manual.

10.02.03 Normal Operation

**WARNING:**

Do not operate the engine in an area where flammable vapors such as gasoline or diesel fumes are present. Shut off the engine when in an area where flammable liquids or gases are being handled. Failure to observe these precautions could result in serious injury or death.

Every engine has an operating range in which it performs most efficiently. The operating range extends from maximum torque rpm at the low end, to engine rated speed at the high end. Most engines deliver best fuel economy when operated in the low- and mid-speed segments of the efficiency range and produce maximum horsepower at rated speed, which is also the recommended maximum speed of the engine. For further engine-specific information, see the engine manufacturer's operation manual.

Prolonged idling of engines is not recommended, and is illegal in some states. Idling produces sulfuric acid that is absorbed by the lubricating oil, and eats into bearings, rings, valve stems, and engine surfaces. If you must idle the engine for cab heating or cooling, use the high idle function of the cruise control switches. An idle speed of 900 rpm should be enough to provide cab heat in ambient temperatures that are above freezing.

If the engine is programmed with an idle shutdown timer, 90 seconds before the preset shutdown time, the 'CHECK' engine light will begin to flash at a rapid rate. If the position of the clutch pedal or service brake changes during this final 90 seconds the idle shutdown timer will be disabled until reset.

10.02.04 Cold-Weather Operation

Satisfactory performance of a diesel engine operating in low ambient temperatures requires modification of the engine, surrounding equipment, operating practices, and maintenance procedures. The lower the temperature, the greater the amount of modification required. For service products approved for use in cold weather for your engine, see the engine manufacturer's engine operation manual.

If satisfactory engine temperature is not maintained, maintenance costs will increase due to greater engine wear. If the engine coolant gets too cold, raw fuel will wash the lubricating oil off the cylinder walls and dilute the crankcase oil, causing all moving parts of the engine to suffer from poor lubrication.

If the engine is in good mechanical condition and the precautions necessary for cold-weather operation are taken, ordinary cold weather will not cause difficulty in starting or loss of efficiency.

The following points are important to observe when operating in cold weather.

- Check for cracks in the battery cases, for corrosion of the terminals, and for tightness of the cable clamps at the terminals.
- Charge the batteries to full capacity. Replace damaged batteries.
- If equipped, turn off the load disconnect switch after the engine is shut down to prevent battery discharge.
- Have the alternator output checked at an authorized Western Star service provider.
- Check the condition and tension of the drive belts.
- See the engine manufacturer's operation manual for recommended heaters, low-viscosity lubricating oils, winter-grade fuels, and approved coolants.
- Periodically check the coolant mixing ratio (concentration of antifreeze in the coolant). Add more if necessary.
- At outside temperatures below -4°F (-20°C), a coolant preheater is recommended.

**NOTICE:**

For Detroit engines (EPA07 and newer), use of a winterfront is not recommended, as it can cause false fault codes with the engine and aftertreatment system, and possible emission component failures.

If using a winterfront, leave at least 25 percent of the grille opening exposed in sectioned stripes that run perpendicular to the charge-air-cooler tube-flow direction. This assures even cooling across each tube and reduces header-to-tube stress and the chance of component failure.

For engine-specific guidelines, see below:

Cummins engines: A winterfront may be used to improve cab heating while idling, but only when the ambient temperature remains below 10°F (-12°C).

Detroit engines: Use of a winterfront is not recommended. Using a winterfront can cause excessive fan run time, increased fuel consumption, and failure of the DEF system heaters to operate correctly, resulting in fault codes, poor performance, and power reduction. A winterfront should only be used temporarily in the following situations:

- To improve cab heating while idling in an extremely cold ambient temperature;
- When the ambient temperature remains below -22°F (-30°C) and the engine is unable to maintain a running coolant temperature of 175°F (80°C) during normal over-the-road operation.

10.02.05 High-Altitude Operation

Engines lose horsepower when operated at high altitude because the air is too thin to burn as much fuel as at sea level. This loss equals about three percent for each 1000 ft (300 m) altitude above sea level for a naturally aspirated engine.

All engines used on Western Star vehicles are altitude-compensated by the use of a turbocharger. This reduces smoky exhaust at high altitudes, requires less downshifting, and allows the engine to make better use of its fuel. Nevertheless, shift gears as needed to avoid excessive exhaust smoke.

10.03 Engine Shutdown

1. With the vehicle stopped, set the parking brake and place the transmission in neutral.

**NOTICE:**

Idle the engine one to two minutes before shutting it down. After hard operation, shutting down the engine without idling may cause damage to the turbocharger.

2. Allow the engine to idle one to two minutes before shutting it down. This allows the lubricating oil and the coolant to carry heat away from the combustion chambers, bearings, shafts, and seals.
3. Turn off the ignition switch and shut down the engine.

10.04 Engine Protection—Warning and Shutdown

The driver should be familiar with the vehicle warning system in order to bring the vehicle to a safe stop if necessary. If the driver doesn't understand how the warning system works, the driver may not be able to utilize the advantage of the advance warning system to pull over appropriately.

The engine will begin a warning and derate and/or shutdown process if the engine coolant temperature, coolant level, engine oil pressure, or exhaust aftertreatment system (ATS) reach preset levels. On some engines, the warning

process will begin when the engine oil temperature, engine coolant temperature, or the intake air temperature reach preset levels. Detroit™ engines may also begin the warning and shutdown process if water is detected in the fuel.

See the engine manufacturer's operation manual for specific details for your vehicle. See [14.01 Greenhouse Gas Emissions and Fuel Consumption Standards](#) for the warning and shutdown modes associated with the ATS.

Electronic engine protection can be specified as either SHUTDOWN or WARNING and DERATE.



WARNING:

When the STOP engine or CHECK engine lamp illuminates, most engines are programmed to shut down automatically within 30 seconds. The driver must immediately move the vehicle to a safe location at the side of the road to prevent causing a hazardous situation that could cause bodily injury, property damage, or severe damage to the engine.

In SHUTDOWN mode, the red STOP engine lamp will illuminate when the problem is serious enough to reduce power or speed. See Fig.207, [Engine Warning Lamps](#). Engine power will ramp down, then the engine will shut down if the problem continues while in derate mode. The driver has 30 or 60 seconds (depending on the critical fault type) after the STOP engine lamp illuminates to move the vehicle safely off the road. If the vehicle cannot be moved to a safe location within that time, turn the ignition switch to OFF for at least five seconds, then restart the engine. Repeat this action until the vehicle is safely off the road.

NOTE: In addition to the warning lamp, the driver display screen will present a warning message when the engine is in SHUTDOWN mode. See Fig.208, [Shutdown Alert](#). For vehicles with Detroit engines, the time remaining before shutdown is displayed.

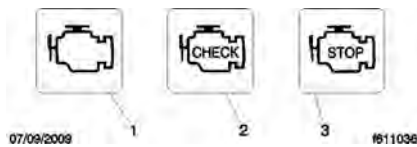

1. Malfunction Indicator Lamp (MIL)
2. CHECK Engine Lamp

3. STOP Engine Lamp

Fig 236, Engine Warning Lamps

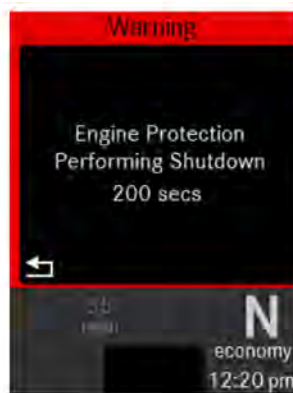

On vehicles with Detroit engines only, the time remaining before shutdown is displayed.

Fig 237, Shutdown Alert

On vehicles with Detroit engines only, the time remaining before shutdown is displayed.

Do not operate the vehicle further until the problem causing the shutdown has been corrected.

Some vehicles may have a shutdown override switch, which can be used to momentarily override the shutdown sequence. This switch resets the shutdown timer, restoring power to the level before the derate. The switch must be pressed again after five seconds to obtain a subsequent override. See Fig.209, [Shutdown Override Switch](#).

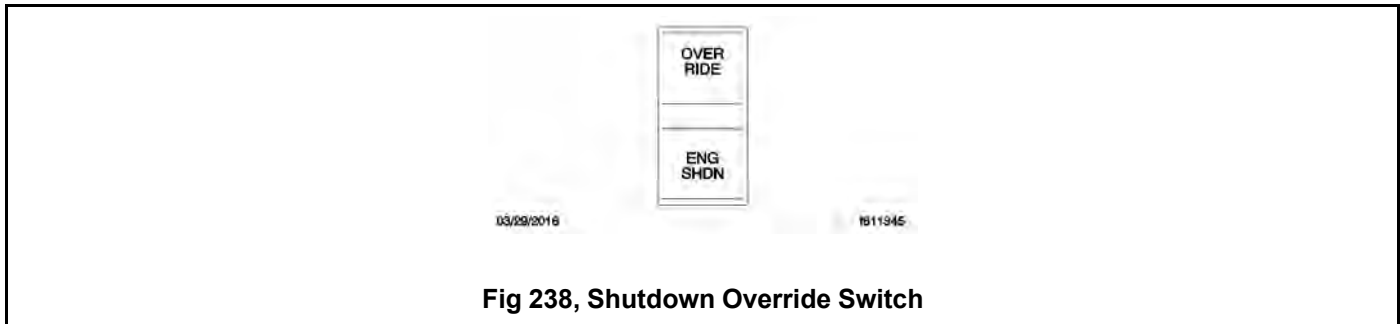
**NOTICE:**

When the derate process begins, immediately get the vehicle serviced in order to prevent severe damage to the engine.

Detroit engines may begin a warning and derate process if water is detected in the fuel, or for high engine coolant temperature. In WARNING and DERATE mode, the CHECK engine, STOP engine, or MIL lamp will illuminate to indicate an engine problem that requires service and the engine controls will begin a derate of engine output. Continuing to run the engine while it is in derate mode could cause severe damage to the engine.

- 11.01 Engine Idle Limiting 224
 - 11.01.01 Idle Shutdown Timer..... 224
- 11.02 Optimized Idle®..... 224
 - 11.02.01 General Information..... 224
 - 11.02.02 Activating Optimized Idle 225
 - 11.02.03 Reactivating Optimized Idle..... 227
 - 11.02.04 Deactivating Optimized Idle..... 228
- 11.03 Power Takeoff (PTO) Governor..... 228
- 11.04 PTO Instrumentation Unit Controls..... 229

11. Optional Engine Systems

11.01 Engine Idle Limiting

11.01.01 Idle Shutdown Timer

This feature is an optional 1- to 100-minute idle shutdown system with a timer on the driver display screen. Its purpose is to conserve fuel by eliminating excessive idling. Idle shutdown timing and parameters are programmable. See the engine manufacturer's operation manual for specific details for your vehicle.

11.02 Optimized Idle®

11.02.01 General Information

Optimized Idle is an optional feature on vehicles equipped with Detroit engines. Optimized Idle reduces engine idle time by running the engine only as required when the vehicle is parked.

Optimized Idle automatically shuts down and restarts the engine as needed to:

- Keep the engine oil temperature between programmed limits;
- maintain battery voltage;
- keep the cab and sleeper areas at the thermostat setting; and
- in coordination with the Dual HVAC system (if equipped), maintain the battery and assist in HVAC.

The benefits of the system include reduced engine idle time, fuel savings, reduction of exhaust emissions and noise, increased starter and engine life, and a reduced chance of dead batteries.

Optimized Idle operates in the following modes:

- Cold startability mode and battery mode: Both modes keep the battery charged and engine oil temperature between programmed limits.
- Interior comfort mode (for sleeper cabs without a Dual HVAC system): Keeps the cab and sleeper at a constant preset temperature, in addition to all functions available in cold startability and battery modes. Extended and continuous run modes allow the engine to keep running longer if necessary.
- Interior comfort mode with a Dual HVAC system: Keeps the cab and sleeper at a constant preset temperature, in addition to all functions available in cold startability and battery modes.

In cold startability mode, Optimized Idle starts the engine when engine oil temperature drops to a programmable preset lower limit. The engine is shut down when engine oil temperature reaches a programmable upper limit, unless the requirements of other active modes require the engine to keep running.

In battery mode, the engine runs for 2 hours before shutting down. On vehicles without a Dual HVAC system, the engine runs an additional 2 hours in extended mode if necessary, and continuously in continuous mode. When in continuous mode, the driver display indicates Optimized Idle status as 'continuous battery mode.' Continuous mode may indicate a problem, such as a bad battery.

Interior comfort mode controls the temperature set point, which is the desired temperature of the cab and sleeper, and the comfort zone, which is the allowed temperature deviation from the set point before the engine starts.

Interior comfort mode with a Dual HVAC system operates with the following parameters regarding the set point and comfort zone:

- If the bunk area temperature reaches more than 10°F (5.5 °C) above the set point the comfort zone is exceeded and the Dual HVAC system immediately requests the engine to start for comfort support cooling.
- Bunk area temperatures 5 to 10°F (2.8 to 5.5°C) above the set point for over twenty minutes causes the Dual HVAC system to request the engine to start for comfort support cooling.
- If the bunk area temperature drops to more than 10°F (5.5 °C) below the set point, the comfort zone is exceeded and the Dual HVAC system immediately requests the engine to start for comfort support heating.

- Temperatures 5 to 10°F (2.8 to 5.5 °C) below the set point for over twenty minutes causes the Dual HVAC system to request the engine to start for comfort support for heating.

In extreme ambient conditions, comfort mode may stay on continuously.

NOTE: If the mode settings are changed while in one mode, the system may continue running in another mode.

When Optimized Idle is on, it may turn off these functions to reduce stress on the batteries:

- Cab climate control fan
- Sleeper climate control fan
- Mirror heat
- Fuel/water separator heat
- Seat heat
- Advertising light
- Auxiliary circulation fan (windshield)
- Air dryer

11.02.02 Activating Optimized Idle

The vehicle must be in neutral gear, the hood latched, and the park brake set for Optimized Idle to work. Failure to meet these conditions result in a checklist pop-up screen showing both the met and unmet conditions. See Fig. 210, [Optimized Idle Activation Conditions Pop-Up](#).

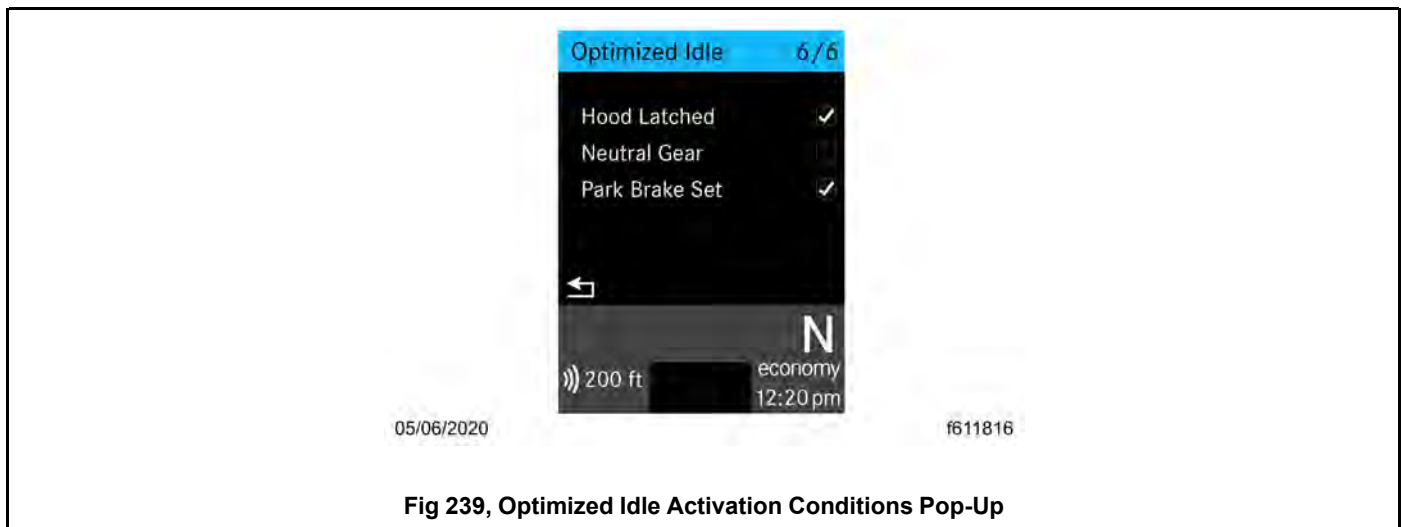

Fig 239, Optimized Idle Activation Conditions Pop-Up

Dismiss the pop-up screen, fix the issue(s), and restart Optimized Idle.

NOTE: Turning the sleeper HVAC fan off turns off the interior comfort mode until the fan is turned back on.

1. Set the parking brake.
2. If open, close and secure the hood.
3. Allow the engine to idle if it is running. If the engine is not running, turn the key to the ON position.
4. Put the transmission in neutral.
5. Navigate to the Optimized Idle screen on the driver display. See Fig.211, [Optimized Idle Start Screen](#).



05/20/2016

f611420

Fig 240, Optimized Idle Start Screen

6. Press OK on the steering wheel switch pod to view the mode option screen. See Fig. 212, [Optimized Idle Mode Selection Screen](#).
7. Select OK to enable Optimized Idle, and, if desired, turn on the interior comfort mode (sleeper cabs only). The current Optimized Idle state is displayed. See Fig. 213, [Optimized Idle State Screen](#).

When Optimized Idle is active, the Optimized Idle telltale illuminates at the bottom of the driver display. See Fig. 214, [Optimized Idle Telltale](#).

If Optimized Idle fails to start, see the driver display for information.

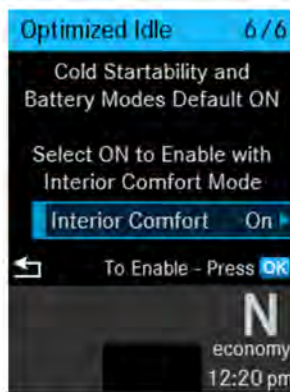

09/09/2016

f611421

Fig 241, Optimized Idle Mode Selection Screen



Fig 242, Optimized Idle State Screen

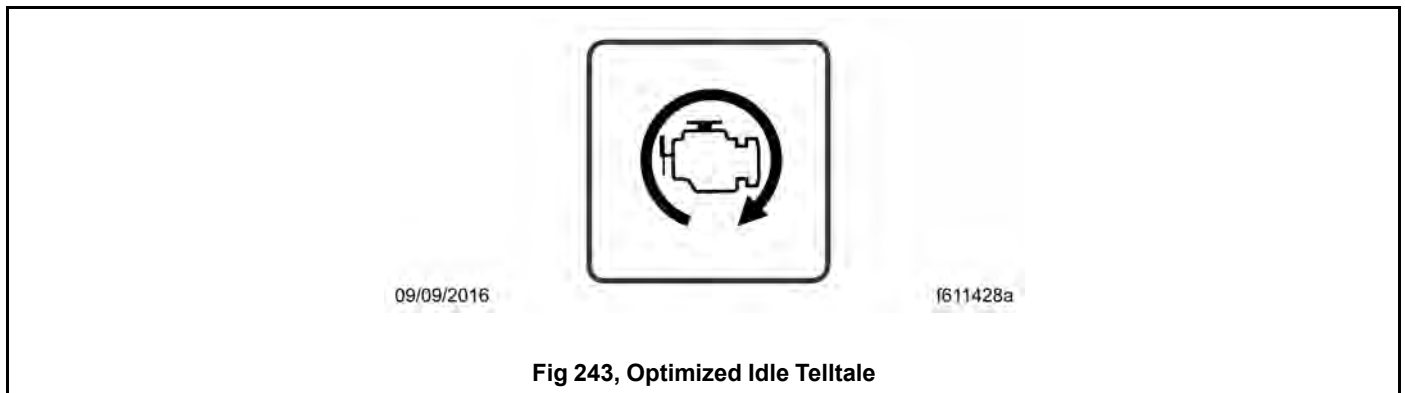

Fig 243, Optimized Idle Telltale

8. If the interior comfort mode is activated (sleeper cabs only), set the desired temperature and fan speed on the sleeper HVAC controls.

The allowable temperature range for Optimized Idle operation is 65 to 80°F (18 to 27°C).

Optimized Idle operates the engine, starting and turning it off as needed to maintain battery charge, engine oil temperature, and cab/sleeper temperature.

11.02.03 Reactivating Optimized Idle

If the hood is opened or the vehicle is put into gear while Optimized Idle is running, the system enters a safety loop and a pop-up appears. See Fig.215, [Safety Loop Pop-Up](#) Restoring operating conditions (e.g. closing the hood or setting the transmission in neutral) and performing a key cycle allows you to reactivate Optimized Idle.

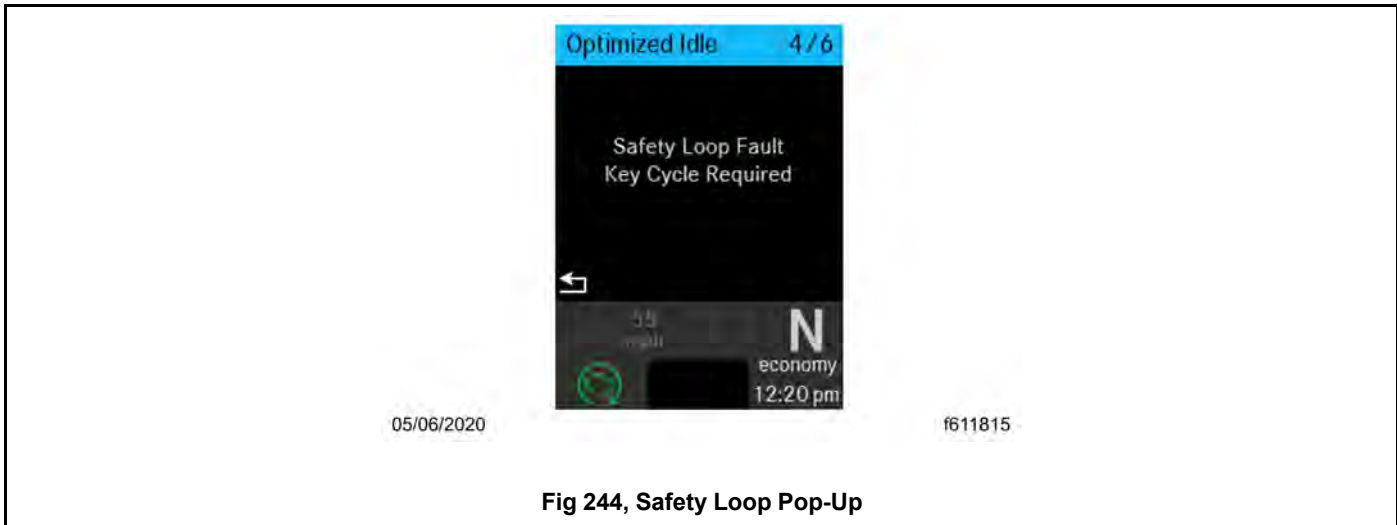

Fig 244, Safety Loop Pop-Up

11.02.04 Deactivating Optimized Idle

Optimized Idle can be shut down by:

- using the Optimized Idle menu screens on the driver display;
- turning off the ignition;
- using the drive-away feature, as follows.
- If the engine is running: Release the parking brakes, put the transmission in gear (automated/automatic transmissions), or depress the clutch (manual transmissions).
- If the engine is not running: Start the engine. Release the parking brakes, put the transmission in gear (automated/automatic transmissions), or depress the clutch (manual transmissions).
- Let the engine return to base idle. The telltale turns off. Optimized Idle is now disabled.

11.03 Power Takeoff (PTO) Governor



WARNING:

To avoid injury, do not install a PTO that is not Detroit Diesel approved onto a Detroit™ Transmission. Use of a non-Detroit Diesel approved PTO with a Detroit Transmission could result in unintended operation which could lead to severe personal injury.

Engine power takeoffs (PTO) tap into engine power to run auxiliary devices, such as hydraulic pumps that power additional equipment.

The following are general guidelines for operating a PTO.

1. Set the parking brake and put the transmission in neutral.
2. Press the dash PTO switch. Release the switch when the light begins to blink.

When the light illuminates steadily, the PTO is engaged and ready to operate. In stationary mode, the vehicle must remain in neutral with the parking brake set.

3. To activate mobile mode, depress the service brake pedal, then shift from neutral to reverse, 1st, or 2nd gear. The clutch opens and the PTO disengages for a moment.

4. Touch the accelerator pedal to close the clutch and engage the PTO in mobile mode. The PTO may be operated with the transmission in neutral or reverse, and 1st and 2nd gears only.

NOTE: Do not attempt to change gears while the vehicle is moving. The transmission ignores the request.

5. To deactivate mobile mode, bring the vehicle to a stop. The clutch opens and shuts down power to the PTO.
6. To resume stationary mode, shift to neutral. The PTO engages.
7. To deactivate PTO, press the PTO switch again. When the light in the switch goes out, power to the PTO is shut off.

11.04 PTO Instrumentation Unit Controls

If configured for ICU speed control, PTO screens can be accessed under the Vehicle Settings menu.

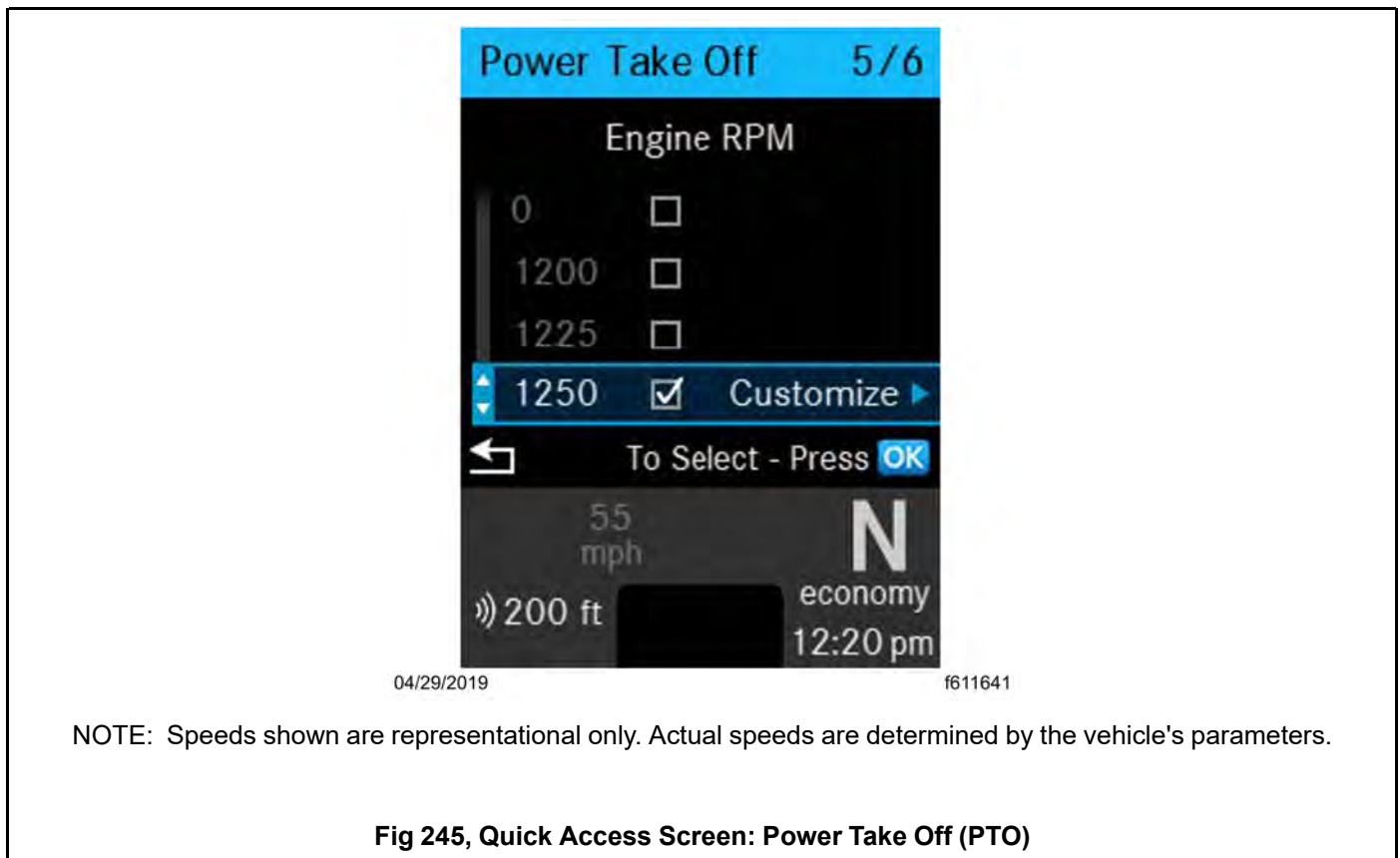

After the Power Take Off (PTO) is engaged using the PTO switch, available PTO speeds are indicated by check boxes on the Power Take Off Screen in the instrumentation unit. See Fig.216, [Quick Access Screen: Power Take Off \(PTO\)](#).

PTO speed 1 is selected initially. If a speed is out of range it is not available to select. If a PTO speed is available for customization, it is indicated with a Customize option.

12.01 Air Brake System	233
12.01.01 Air Brake System, General Information	233
12.01.02 Air Brake System Operation.....	233
12.01.03 Automatic Slack Adjusters	235
12.02 Engine Brake	236
12.02.01 General Information, Engine Brake.....	236
12.02.02 Engine Brake Operation	237
12.03 Exhaust Braking Systems	238
12.03.01 Exhaust Brake Switch.....	238
12.03.02 Mercedes-Benz Exhaust Brake	239
12.03.03 Pacbrake® Exhaust Brake.....	240
12.03.04 Pacbrake Operation (Caterpillar).....	240
12.03.05 Allison World Transmission	241
12.04 Hydraulic Brake System.....	241
12.04.01 Hydraulic Brake System, General Information	241
12.04.02 Hydraulic Brake System Operation	241
12.05 Meritor WABCO® Antilock Braking System	242
12.05.01 General Description	242
12.05.02 Trailer ABS Compatibility	243
12.05.03 Automatic Traction Control.....	243
12.06 Bendix® Intellipark® Electronic Parking Brake Control and Trailer Air Supply Control	244
12.06.01 Important Safety Information	244
12.06.02 Identifying the Intellipark System	244
12.06.03 Vehicle Startup	245
12.06.04 Setting and Releasing the Parking Brake	245
12.06.05 Anti-Roll-Away Feature.....	246
12.06.06 Exhaust-at-Speed	247
12.06.07 Setting and Releasing the Parking Brakes on a Non-Towing Vehicle	247
12.06.08 Setting the Parking Brakes on a Non-Towing Vehicle	247
12.06.09 Towing Vehicle Combination Controls	248
12.06.10 Releasing and Setting the Parking and Spring Brakes on a Tractor-Trailer Combination	248

12.06.11 Release the Parking Brake on the Tractor	248
12.06.12 Release the Spring Brakes on the Trailer	249
12.06.13 Setting the Spring Brakes on a Tractor-Trailer Combination	249
12.06.14 System Faults	250
12.06.15 Parking with a Fault	252
12.06.16 Starting After a Fault	252

12. Brake Systems

12.01 Air Brake System

12.01.01 Air Brake System, General Information

A dual air brake system consists of two independent air systems that use a single set of brake controls. Each system has its own reservoirs, plumbing, and brake chambers. The primary system operates the service brakes on the rear axle; the secondary system operates the service brakes on the front axle. Service brake signals from both systems are sent to the trailer.

**WARNING:**

Do not operate the vehicle with the front brakes backed off or disconnected. Backing off or disconnecting the front brakes will not improve vehicle handling and may lead to loss of vehicle control, resulting in property damage or personal injury.

The warning light and buzzer come on if air pressure drops below 64 to 76 psi (441 to 524 kPa) in either system. If this happens, check the dual system air pressure gauge to determine which system has low air pressure. Although the vehicle's speed can be reduced using the brake pedal, either the front or rear service brakes do not operate at full capacity, causing a longer stopping distance. Bring the vehicle to a safe stop and have the air system repaired before continuing.

IMPORTANT: In the event of a total loss of service brakes with full system air pressure, use the parking brake control valve (yellow knob) to bring the vehicle to a complete stop in the safest location possible.

Before a vehicle with insufficient system air pressure can be moved, the spring parking brakes must be released by applying an external air source at the gladhands, or by manually caging the spring parking brakes.

**WARNING:**

Do not cage the spring parking brakes and then drive the vehicle. There would be no means of stopping the vehicle, which could result in serious personal injury or vehicle damage. Before caging the spring parking brakes, make the connection to a towing vehicle or chock the tires.

After correcting the brake system problem, uncage the spring parking brakes before resuming normal vehicle operation.

Primary Air Brake System

Loss of air pressure in the primary air system causes the rear service brakes to become inoperative. The secondary air system continues to operate the front brakes and the trailer brakes (if equipped).

Secondary Air System

Loss of air pressure in the secondary air system causes the front axle brakes to become inoperative. The primary air system continues to operate the rear service brakes and the trailer brakes (if equipped).

12.01.02 Air Brake System Operation

Before driving your vehicle, allow time for the air compressor to build up a minimum of 100 psi (689 kPa) pressure in both the primary and secondary systems. Monitor the air pressure system by observing the dual system air pressure gauge and the low-air-pressure warning light and buzzer. The warning light and buzzer shut off when air pressure in both systems reaches 64 to 76 psi (441 to 524 kPa).

IMPORTANT: Before driving the vehicle, secure all loose items in the cab so that they do not shift forward during a full brake application. Make sure all passengers are wearing seat belts.

During normal brake stops, depress the brake pedal until braking action slows down the vehicle. Increase or decrease the pressure on the pedal so that the vehicle comes to a smooth, safe stop. Apply the parking brake if the vehicle is to be parked.

IMPORTANT: An air brake proportioning system may be used in tractor air brake systems when the vehicle is not equipped with antilock braking system (ABS). When operating in bobtail mode, the rear brake chambers (on which the axle load has been greatly reduced) receive reduced (proportional) air pressure, while the front axle brake chambers receive full (normal) air pressure. This results in a different brake pedal "feel," as the pedal seems to require more travel and/or effort to slow or stop the vehicle. However, the air brake proportioning system actually improves vehicle control when the tractor is in bobtail mode. When the tractor is towing a trailer, the rear brake chambers receive full (normal) application air pressure.

When parking a vehicle attached to a trailer that does not have spring parking brakes, apply the tractor parking brake. Chock the trailer tires before disconnecting the vehicle from the trailer.

**WARNING:**

If a trailer or combination vehicle is not equipped with spring parking brakes, do not park it by pulling out only the trailer air supply valve knob. This would apply only the trailer service brakes. If air were to bleed from the trailer brake system, the trailer brakes would release, possibly causing an unattended runaway vehicle.

**NOTICE:**

Never apply the service and spring parking brakes simultaneously. To do so transmits excessive input force to the brake components, which could damage or cause eventual failure of brake actuating components.

Brake Hand Controls

The trailer brake lever (hand control valve) is used for applying the trailer brakes without applying the truck or tractor service brakes. It is usually mounted on the right-hand control panel. See Fig.217, [Right-Hand Control Panel](#). The valve can be partially or fully applied, but in any partially applied position, it is overridden by a full application of the brake pedal. Moving the lever down applies the trailer brakes, while moving it up releases the trailer brakes. The lever automatically returns to the up position when it is released.

**WARNING:**

Do not use the trailer service brakes for parking; they are not designed for this purpose. If air bleeds out of the trailer air tank during parking, the vehicle could roll, causing serious personal injury or property damage.



11/29/2022

f612193

- | | |
|-------------------------------|--------------------------|
| 1. Parking Brake Control | 3. Hazard Warning Switch |
| 2. Trailer Air Supply Control | 4. Trailer Brake Control |

Fig 246, Right-Hand Control Panel

The red octagonal-shaped knob in the control panel actuates the trailer air supply valve. See Fig. 217, [Right-Hand Control Panel](#). After the vehicle's air hoses are connected to a trailer and the pressure in both air systems is at least 65 psi (448 kPa), the trailer air supply valve must be pushed in. It should stay in to charge the trailer air supply system and to release the trailer spring parking brakes.

Pull the trailer air supply valve out before disconnecting a trailer or when operating a vehicle without a trailer.

If pressure in both air systems drops to 20 to 45 psi (138 to 310 kPa), the red trailer air supply valve and yellow parking brake valve automatically pop out, applying both the tractor and trailer spring parking brakes. If the trailer is not equipped with spring parking brakes, the trailer service brakes are applied.

The yellow diamond-shaped knob in the control panel actuates the parking brake valve. See Fig. 217, [Right-Hand Control Panel](#). Pulling out the parking brake valve applies both the tractor and trailer spring parking brakes and automatically causes the trailer air supply valve to pop out. Pushing in the parking brake valve releases the tractor parking brakes.



NOTICE:

Do not use the spring parking brakes if the service brakes are hot, such as after descending a steep grade. To do so could damage the brakes. Allow hot brakes to cool before using the spring parking brakes.

Do not use the spring parking brakes during freezing temperatures if the service brakes are wet. To do so could cause them to freeze. If the brakes are wet, drive the vehicle in low gear and lightly apply the brakes to heat and dry them.

If the trailer is not equipped with spring parking brakes, pulling out the parking brake valve applies the tractor parking brake and the trailer service brakes. When the tractor and trailer parking brakes (or trailer service brakes) are both applied, the trailer brakes are released by pushing in the trailer air supply valve, leaving the tractor parking brake applied. Air pressure in the primary or secondary reservoir must be at least 65 psi (448 kPa) before the tractor spring parking brakes, or the trailer service or spring parking brakes, can be released.

12.01.03 Automatic Slack Adjusters

Automatic slack adjusters should never be manually adjusted except during routine maintenance of the foundation brakes (e.g., replacing shoes), during slack adjuster installation, or in an emergency situation.

When the brake pushrod stroke exceeds the legal brake adjustment limit on a vehicle, there is likely a mechanical problem with the foundation brake components or the adjuster is improperly installed.

Visit a repair facility as soon as possible when brakes equipped with automatic slack adjusters are determined to be out of adjustment.

**WARNING:**

Manually adjusting an automatic slack adjuster to bring the pushrod stroke within legal limits is likely masking a mechanical problem. Adjustment is not repairing. Before adjusting an automatic slack adjuster, troubleshoot the foundation brake system and inspect it for worn or damaged components. Improperly maintaining the vehicle braking system may lead to brake failure, resulting in property damage, personal injury, or death.

12.02 Engine Brake

12.02.01 General Information, Engine Brake

Each engine manufacturer uses a specific engine brake for their engine. Regardless of the manufacturer, the engine brake is operated with the principles outlined here. Refer to the engine manufacturer's operation manual for details of their particular engine brake product.

**WARNING:**

To avoid injury from loss of vehicle control, do not activate the engine brake system under the following conditions:

- on wet or slippery pavement, unless the vehicle is equipped with antilock braking system (ABS) and you have had prior experience driving under these conditions;
- when driving without a trailer or pulling an empty trailer;
- if the tractor drive wheels begin to lock, or there is fishtail motion after the engine brake is activated.

NOTE: When the engine brake is active, the engine brake lamp illuminates in the ICU.

Whenever vehicle braking is required on good road conditions, the engine brake may be used in conjunction with the service brakes. There is no time limit for operation of the engine brake. However, an engine brake does not provide the precise control of, and is not a substitute for, service brakes.

**WARNING:**

Usage of the engine brake as the primary braking system can cause unpredictable stopping distances, that could result in personal injury or property damage. Service brakes are the primary vehicle braking system.

Since the engine brake is most effective at rated engine speed, gear selection is very important. Gearing down the vehicle within the limits of the rated engine speed makes the engine brake more effective. Recommended engine braking speed is above 1800 rpm and below the rated speed, which is 950 rpm.

"Control speed" is the speed at which the engine brake performs 100 percent of the required downhill braking, resulting in a constant speed of descent. The control speed varies, depending on vehicle weight and the downhill grade.

For faster descent, select a higher gear than that used for control speed. Service brakes must then be used intermittently to prevent engine overspeed and to maintain desired vehicle speed.

For slower descent, select a lower gear, being careful not to overspeed the engine. Occasional deactivation of the engine brake may be necessary to maintain the designated road speed under these conditions.

If the engine is equipped with both cruise control and an engine brake, the engine brake can operate automatically while cruise control is activated. The maximum amount of braking is selected with the engine brake control. When the vehicle returns to the set cruise speed, the engine brake turns off.

The engine brake only operates when the following conditions are met:

- The accelerator pedal is released.
- The clutch pedal is released (if equipped).
- The engine speed is greater than the rated speed, which is 950 rpm.
- The road speed is greater than 0 mph (programmable).
- The ABS is not active.
- The engine is not in PTO mode.
- The torque converter is in lockup (for automatic transmissions).

NOTE: The engine brake is disabled when the engine speed is below 850 rpm.

ABS has the ability to turn the engine brake off if wheel slip is detected. The engine brake automatically turns back on once wheel slip is no longer detected.

12.02.02 Engine Brake Operation

**NOTICE:**

Do not allow the engine to exceed its governed speed, or serious engine damage could result.

NOTE: Depending on the brake type, the engine brake may be disabled when engine temperature falls below a set level.

The engine brake control is located on the right-hand steering column lever. At the top position, the engine brake is off, and at the three lower positions, the engine brake is on and the intensity (low, medium, high) increases with each step down. See Fig.218, [Engine Brake Positions, Right-Hand Steering Column Lever](#).

NOTE: The cruise control system and safety systems may activate the engine brake regardless of the lever position.

NOTE: On vehicles equipped with a Detroit automated transmission, setting the engine brake with the cruise control set activates Deceleration Mode. Setting the cruise control while the engine brake is on activates Descent Control Mode. For information on these modes, see "Cruise Control", see [8.01.01 General Description, Standard Adaptive Cruise Control](#).

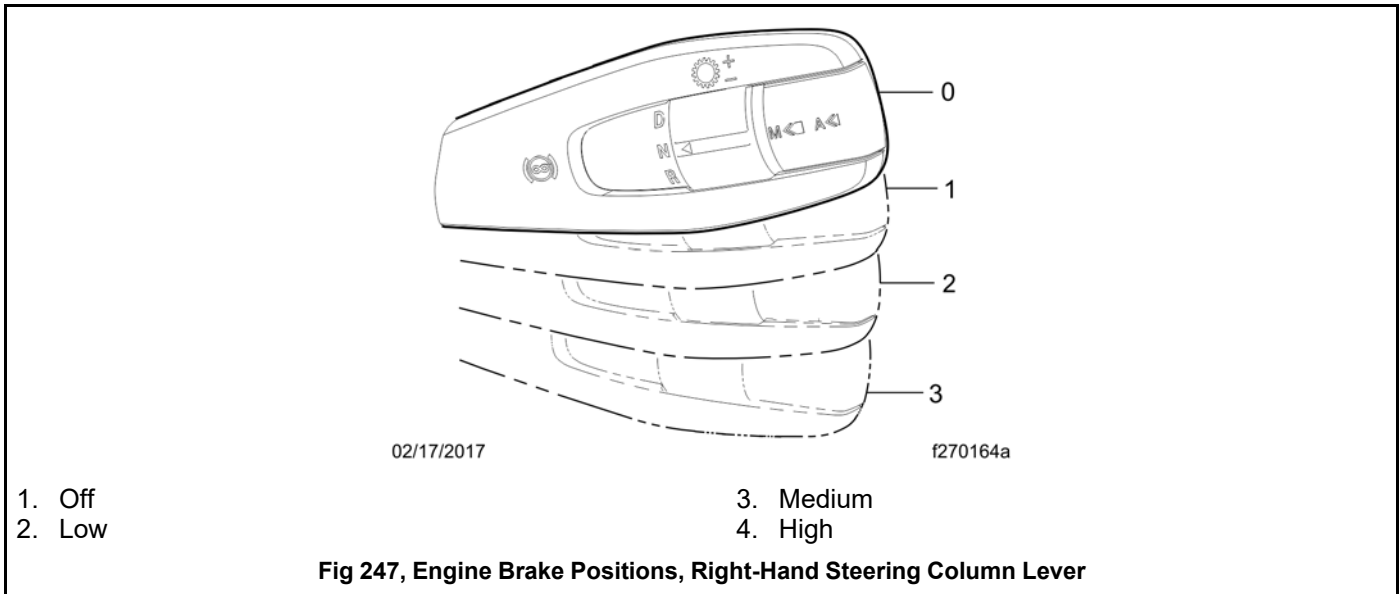

12.03 Exhaust Braking Systems

12.03.01 Exhaust Brake Switch

The optional exhaust brake is controlled by a dash-mounted rocker switch to help slow the vehicle when the accelerator is released.

To turn the exhaust brake on, press on the upper part of the rocker (at the light inside the switch). The exhaust brake turns off automatically. See Fig.219, [Exhaust Brake Switch](#) or see Fig.220, [Exhaust Brake Switch](#).

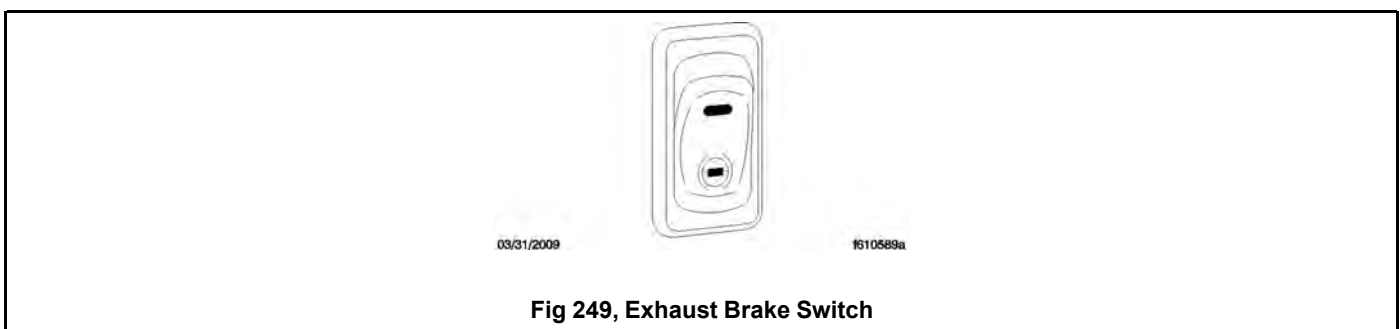
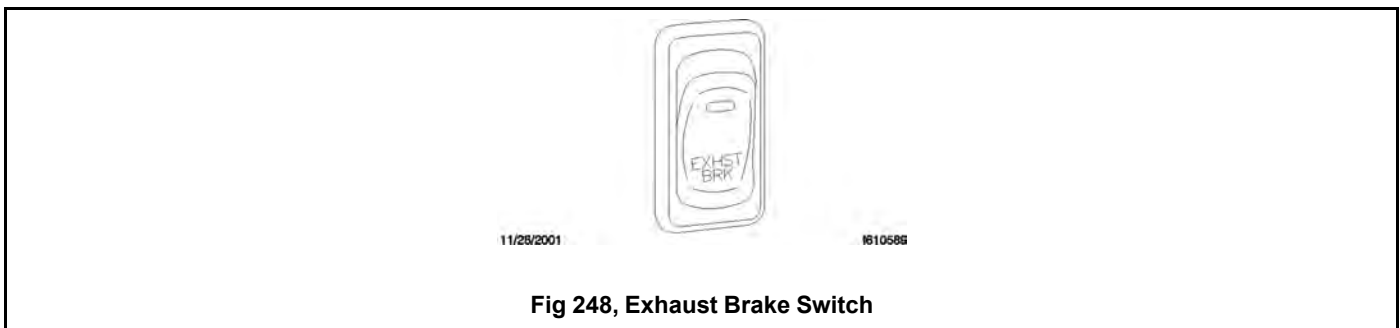

When the exhaust brake switch is on, an amber LED illuminates inside the switch. When the panel lights are on, the EXHST BRK legend is backlit in green.

12.03.02 Mercedes-Benz Exhaust Brake

An exhaust brake is an optional auxiliary braking system that assists but does not replace the service brake system. The exhaust brake can be used alone or together with the constant-throttle valves for steep or long grades. The exhaust brake switch located on the control panel, in combination with the accelerator and clutch pedals, allows the driver to make maximum use of the exhaust brake in off-highway and mountain driving as well as in traffic or high-speed highway driving.

When only the exhaust brake is installed, a two-position switch on the dash controls the engine braking system. The exhaust brake is only active when the engine speed is between 1100 and 2700 rpm. Depressing the accelerator or clutch pedal deactivates the exhaust brake. The ABS system, when active, also deactivates the exhaust brake.

The exhaust brake is a butterfly valve mounted in the exhaust pipe. When the driver's foot is not on the accelerator pedal and the upper half of the exhaust brake switch is pressed in, with the amber light on the switch illuminated, an air cylinder shuts the butterfly valve, which restricts the flow of exhaust gases and retards the engine. This retarding action is carried through the engine and drivetrain, slowing the vehicle and reducing the need for frequent service brake applications.

Exhaust brakes are not intended for use as the primary braking system during vehicle operation.

Operating Characteristics

**WARNING:**

Do not use the exhaust brake when driving on slippery or low-traction road surfaces. Failure to follow this precaution could result in a loss of vehicle control and possible personal injury or property damage.

Before starting the engine, make sure that the lower half of the exhaust brake switch is pressed in and the amber light is not illuminated. Do not turn the exhaust brake on until the engine has reached normal operating temperatures.

When you remove your feet from both the accelerator and clutch pedals and the upper half of the exhaust brake switch is pressed in with the amber light illuminated, the exhaust brake is applied. The following conditions should exist if the brake is operating properly:

- A slight change in the sound of the engine may be noticed when the exhaust brake is applied.
- Exhaust smoke should appear normal.
- Engine temperature should remain in the normal operating range.
- Road speed usually decreases when the exhaust brake is applied during a descent. When the vehicle is carrying a heavy load or the grade is extremely steep, you may need to apply the service brakes occasionally.
- Do not expect a retarding effect similar to sudden hard application of the service brakes. The exhaust brake retards the vehicle with a smooth braking effect.
- During a descent, the tachometer usually shows a drop in rpm, depending on the grade and the vehicle load.
- Depending on the grade and vehicle load, you may or may not feel the retarding force acting against your body when the brake is applied. The retarding force of the brake may not always be noticed, but it is actually preventing the vehicle from going much faster.

Make sure the exhaust brake is turned off before shutting down the engine.

Driving Downhill

While approaching a steep grade, make sure that the upper half of the exhaust brake switch is pressed in, with the amber light illuminated. The exhaust brake comes on as soon as you remove your foot from the accelerator pedal. While going down the grade, use a low enough gear to safely descend with a minimum application of the service brakes. As a general guideline, use the same gear as you would to ascend the hill.

**NOTICE:**

Do not allow the engine to exceed its governed speed, or serious engine damage could result.

Apply the service brakes to reduce the engine rpm or make a slower descent by using a lower gear.

12.03.03 Pacbrake® Exhaust Brake

The Pacbrake exhaust brake is intended as a supplement to the service brakes and does *not* bring the vehicle to a complete stop. The Pacbrake assists in the control or reduction of road speed in conjunction with, or independent of, the service brakes. The amount of retarding or braking force is controlled by the driver.

12.03.04 Pacbrake Operation (Caterpillar)

The Pacbrake is controlled by the exhaust brake switch and the throttle pedal. All applications are additionally affected, controlled, or governed by engine speed through transmission gear selection. The Allison MD3060 transmission has automatic downshifting when the exhaust brake is requested. See the information on the "Allison World Transmission" later in this chapter.

On some applications, when the Pacbrake is in use, it may be necessary to check that the cruise control is not set and that the throttle is in the idle position.

On some applications, the engine, transmission, cruise control, and the Pacbrake exhaust brake may electronically interact with each other, which automatically operates their functions. Following are some examples of the programmed options that may be available with the cruise control in the on position:

- The coast mode engages the Pacbrake when the service brake is applied and disengages when the service brake is released.
- The latch mode engages the Pacbrake when the service brake is applied and the Pacbrake remains on after the service brake is released. The Pacbrake is disengaged when another input (depressing the throttle or clutch, engine speed drops below 800 rpm, or the exhaust brake switch is turned off) is supplied.
- The manual mode does not require the cruise control switch to be on, and operates the Pacbrake manually at the driver's discretion.

The amount of braking power the engine develops is related to the speed (rpm) of the engine. The higher the engine rpm, the greater the retarding power.

Certain conditions may require that the transmission be downshifted in order to generate adequate rpm for the amount of retarding power required. Pacbrake exhaust brakes are designed and approved for safe use at 300 rpm above the engine's maximum governed rpm. Refer to individual engine manufacturer's specifications.

The Pacbrake functions best if it is used all of the time. However, if the vehicle is used inconsistently or seasonally, it may be necessary to perform a preventive maintenance procedure.

1. With the engine shut down, use any oil-free or nonpetroleum-based high-heat lubricant, and spray or coat a sufficient amount on the restrictor valve shaft and the attaching locations at each end of the actuation cylinder. See Fig.221,[Pacbrake Exhaust Brake and Air Cylinder](#).

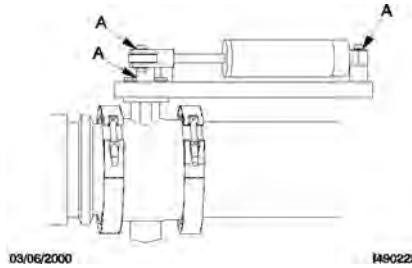

A. Lubrication Point

Fig 250, Pacbrake Exhaust Brake and Air Cylinder

2. With your hands or a pair of pliers, motion the valve several times to distribute the lubricant down the shaft and the attaching locations.

NOTE: Starting the engine and idling for short periods of time is not recommended. During a cold engine start-up, enough moisture is developed within the engine and the exhaust system to create a corrosion hazard that could affect the future operation of the Pacbrake. The brake housing may trap water in the valve shaft bore causing corrosion in an improperly functioning or nonfunctioning brake. If it is necessary to periodically start the engine, it is recommended that normal operating temperatures be attained before shutting down the engine.

12.03.05 Allison World Transmission

Pacbrake exhaust brakes used with the Allison World Transmission MD series, are interfaced with the transmission electronic control module (ECM). An exhaust-brake-enabled transmission ECM will usually provide converter lockup in gears two through six. Effective exhaust braking begins when the transmission automatically downshifts into fifth gear (62 mph or less). Once on, the Pacbrake exhaust brake will control road speed and/or slow the vehicle sufficiently that the transmission will automatically downshift, if necessary, to Allison's preselect mode.

The preselect mode is normally assigned to second gear; however, the transmission can be reprogrammed by an Allison Transmission Distributor to third or fourth gear, should the operator desire. If additional retarding power is required before the automatic downshifting occurs, you can select a lower transmission gear on the Allison shift selector.

12.04 Hydraulic Brake System

12.04.01 Hydraulic Brake System, General Information

The hydraulic brake system includes a power booster, main cylinder, reservoir, hydraulic lines, a brake rotor on each wheel hub, and a brake caliper and pad assembly at each rotor.

The main cylinder controls braking power to the front and rear brakes. The Bendix Hydro-Max® power booster is attached to the rear of the main cylinder and is connected to the power steering system (which provides pressurized power steering fluid). An electrical backup pump operates if there is inadequate fluid flow from the power steering pump to the power booster.

The brake system warning light illuminates if there is a problem within the system. Bring the vehicle to a safe stop and correct the problem before continuing operation of the vehicle.

12.04.02 Hydraulic Brake System Operation

IMPORTANT: Make sure that the fluid level in the main cylinder reservoirs is at the bottom of the fill-neck. See Fig. 222, [Hydraulic Brake Fluid Reservoir \(Bosch reservoir shown, Bendix reservoir similar\)](#). Use only heavy-duty brake fluid, DOT 3, in the hydraulic brake system.

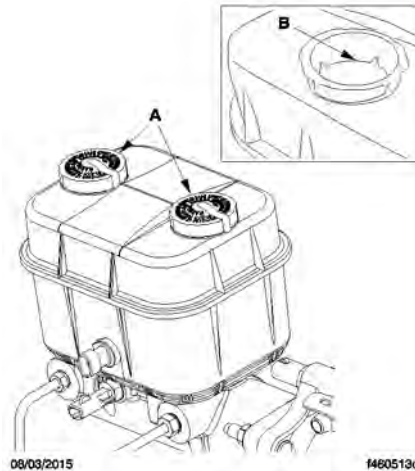

A. Open caps and check fluid level.

B. Fill to this level.

Fig 251, Hydraulic Brake Fluid Reservoir (Bosch reservoir shown, Bendix reservoir similar)

IMPORTANT: Before driving the vehicle, secure all loose items in the cab so that they do not shift forward during a full brake application. Make sure all passengers are wearing seat belts.

During normal brake stops, depress the brake pedal until braking action slows down the vehicle. Increase or decrease the pressure on the pedal so that the vehicle comes to a smooth, safe stop. Apply the parking brake if the vehicle is to be parked.

When parking a vehicle attached to a trailer, apply the tractor parking brake. Chock the trailer tires before disconnecting the vehicle from the trailer.

12.05 Meritor WABCO® Antilock Braking System

12.05.01 General Description

The Meritor WABCO Antilock Braking System (ABS) is an electronic wheel speed monitoring and control system that works with the brake system. ABS passively monitors vehicle wheel speed at all times, and controls wheel speed during emergency stops or wheel lock situations.



NOTICE:

An accumulation of road salt, dirt, or debris on the ABS tone wheels and sensors can cause the ABS warning light to come on. If the ABS light does come on, the tone rings and sensors should be inspected for corrosion and serviced if necessary. The service should include cleaning of the tone rings and sensors. If any tone ring on a vehicle shows severe corrosion, all tone rings on that vehicle should be replaced.

During winter months in areas where corrosive materials are used on the highways, periodically clean the underside of the vehicle, including the tone rings and sensors, to ensure proper ABS function and to protect the components from corrosion. Clean more frequently when unusually corrosive chemicals are being used.

IMPORTANT: For proper ABS system operation, do not change tire sizes. The sizes of the tires installed during production are programmed into the electronic control unit (ECU). Installing different-sized tires could result in a reduced braking force, leading to longer stopping distances.

The ABS includes signal-generating tone wheels and sensors located in the wheel hubs of each sensed wheel. The sensors transmit vehicle wheel speed information to an electronic control unit ECU located behind the center dash. The ECU's main circuit interprets the speed sensor signals and calculates wheel speed, wheel retardation, and a vehicle

reference speed. If the calculations indicate wheel lockup, the main circuit signals the appropriate modulator valve to reduce braking pressure. During emergency braking, the modulator valve alternately reduces, increases, or maintains air pressure supply in the brake chamber to prevent front and rear wheel lockup.

The Meritor WABCO ABS combines one front-axle control channel with one rear-axle control channel to form one control circuit. For example, the sensor and modulator valve on the left-front axle form a control circuit with the sensor and modulator valve on the right-rear axle.

The ECU has a safety circuit that constantly monitors the wheel sensors, traction control valve (if equipped), modulator valves, and the electrical circuitry. If the safety circuit senses a failure in any part of the ABS, the tractor warning lamp (TRACTOR ABS) illuminates and the control circuit where the failure occurred is switched to normal braking action. The remaining control circuit retains the ABS effect. Even if the ABS is completely inoperative, normal braking ability is maintained.

The ABS indicator lamp illuminates after the ignition is switched on and goes out within three seconds if the system is functioning correctly. If the ABS indicator lamp does not illuminate, or does not go out after three seconds, have the vehicle serviced before operation.

During emergency or reduced-traction stops, fully depress the brake pedal until the vehicle comes to a safe stop. *Do not pump the brake pedal*. With the brake pedal fully depressed, the ABS controls all wheels to provide steering control and a reduced braking distance.

Although the ABS improves vehicle control during emergency braking situations, the driver still has the responsibility to change driving styles depending on existing traffic and road conditions. For example, the ABS cannot prevent an accident if the driver is speeding or following too closely.

12.05.02 Trailer ABS Compatibility

The Meritor WABCO ABS is designed to communicate with a trailer ABS, if they are compatible. Compatibility is shown with the illumination of the TRAILER ABS lamp during vehicle start-up and fault detection.

The TRAILER ABS lamp does not illuminate unless a compatible trailer is connected to the tractor. The dash-mounted lamp operates as follows when a compatible trailer is properly connected to the tractor:

- When the ignition key is turned to the ON position, the TRAILER ABS lamp illuminates momentarily, then turns off.
- If the lamp illuminates momentarily during vehicle operation, then shuts off, a fault was detected and corrected.
- If the lamp illuminates and stays on during vehicle operation, there is a fault with the trailer ABS. Repair the trailer ABS system immediately to ensure full antilock braking capability.

IMPORTANT: If a compatible trailer is connected, and the lamp is not illuminating momentarily when the ignition key is turned to the ON position, it is possible that the lamp is burnt out.

12.05.03 Automatic Traction Control

Vehicles with electronic engines and ABS may have Automatic Traction Control (ATC). On these vehicles, the ATC system automatically limits wheel spin during reduced-traction situations. In normal braking applications, the standard air brake system is in effect.

An additional solenoid valve is installed. During reduced-traction situations, the ATC solenoid valve controls air pressure to the modulator valves and they in turn increase, hold, or reduce pressure to the appropriate brake chambers to provide better traction whenever wheel spin occurs.

When the ATC system is in the NORMAL mode, it applies gentle braking to the spinning wheel, to feed power to the wheel(s) with better traction. If both wheels are spinning, the system signals the engine to reduce power.

ATC includes a deep snow and mud option to increase available traction on extra soft surfaces like snow, mud, or gravel. A momentary contact rocker switch labeled ATC is located on the dash. Pressing the switch temporarily allows more wheel spin. The activation of the deep snow and mud option is indicated by a flashing WHEEL SPIN lamp. Pressing the switch again cycles the system back to normal operation.

**NOTICE:**

The deep snow and mud option is intended to be used under specific slippery conditions that require momentary increased wheel spin. Using this option for an extended period of time may damage the vehicle brake system.

After the ignition switch is turned on, the TRACTOR ABS lamp and the WHEEL SPIN indicator lamp illuminate for about three seconds. After three seconds, the warning lights go out if all of the tractor's ABS components are working.

IMPORTANT: If any of the ABS warning lights do not work as described above, or illuminate while driving, repair the ABS immediately to ensure full antilock braking capability.

12.06 Bendix® Intellipark® Electronic Parking Brake Control and Trailer Air Supply Control

12.06.01 Important Safety Information

**WARNING:**

No commercial vehicle safety technology replaces a skilled, alert driver exercising safe driving techniques and proactive, comprehensive driver training. Responsibility for the safe operation of the vehicle remains with the driver at all times. Failure to do so can result in personal injury and property damage.

**WARNING:**

The Bendix Intellipark electronic parking brake system is a driver assistance, not driver replacement, technology. Safe driving practices, habits, and driver training are critical for safety on the road. Failure to do so can result in personal injury and property damage.

**WARNING:**

The driver should always manually set the parking brake, and not rely on the Intellipark electronic parking brake system to automatically engage. Failure to do so can result in a roll away situation, causing personal injury and property damage. Data captured through the Intellipark system records any misuse of the system.

12.06.02 Identifying the Intellipark System

The label affixed to the sunvisor, as shown in Fig.223, [Sunvisor Label for Bendix Intellipark Electronic Brake System](#), indicates that the vehicle is equipped with the Bendix Intellipark electronic park brake system.

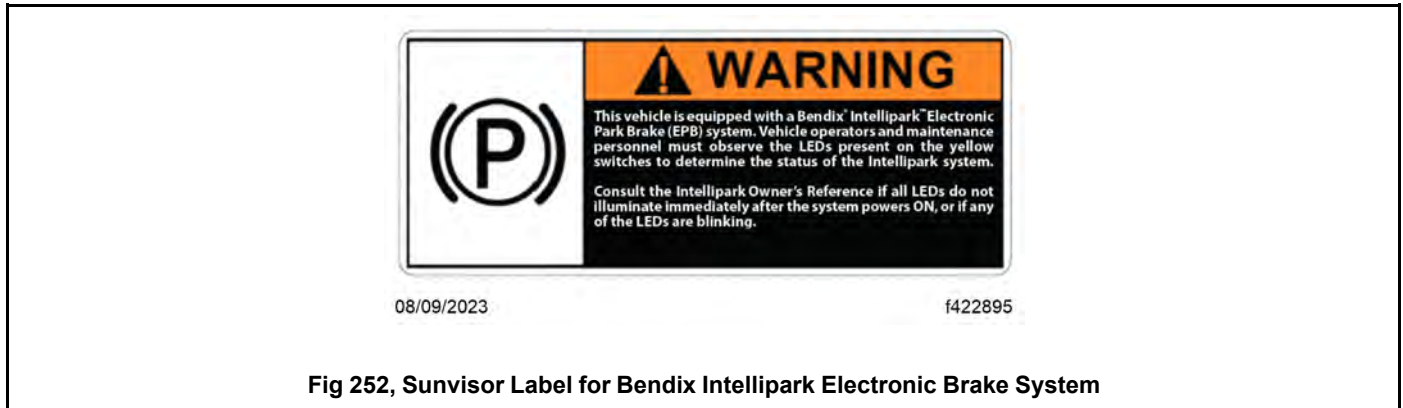

Vehicles equipped with the Intellipark electronic brake system are equipped with an electronic control instead of a pneumatic push/pull knob. See Fig.224, [Comparison of Parking Brake Controls](#).

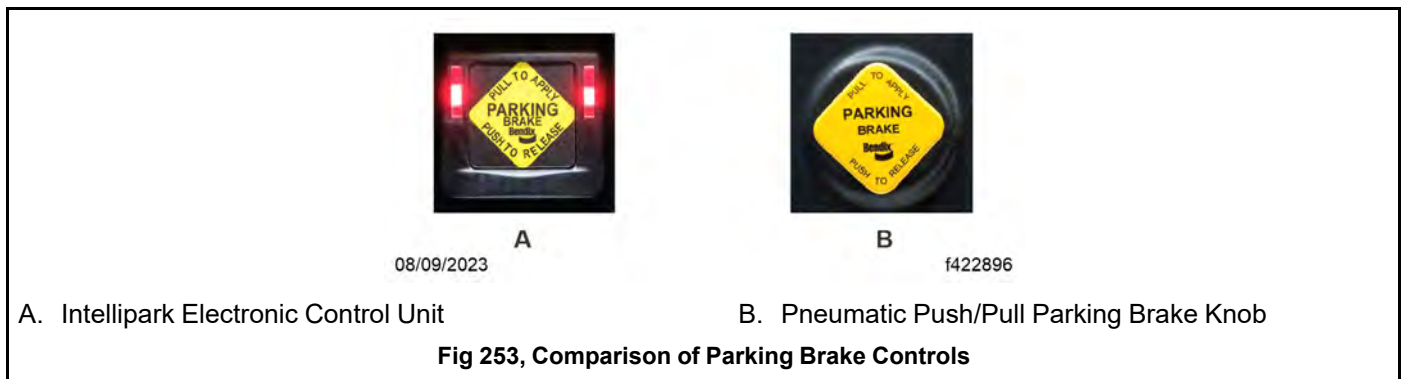

12.06.03 Vehicle Startup

During vehicle startup, the LEDs located on the control unit illuminate for three (3) seconds, turn off for two (2) seconds, then indicate the current parking brake status. At normal startup the parking brake status should indicate that the park brake is set by the LEDs being illuminated. See Fig.225, [Parking Brake Set Status After Startup](#). After the brake pedal is depressed and the ignition power is on, the driver can release the parking brake.

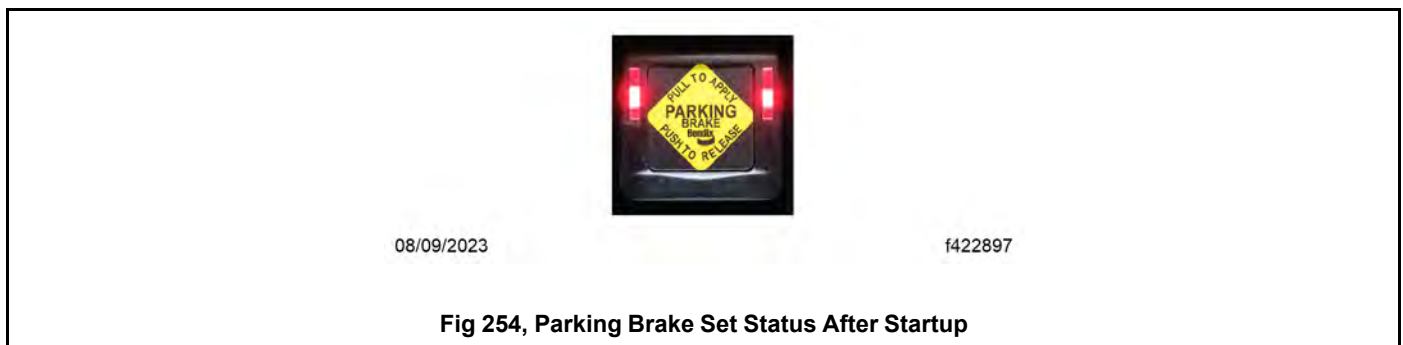

12.06.04 Setting and Releasing the Parking Brake

See Fig.226, [Operating the Parking Brake Control](#) for instructions for setting and releasing the parking brake.

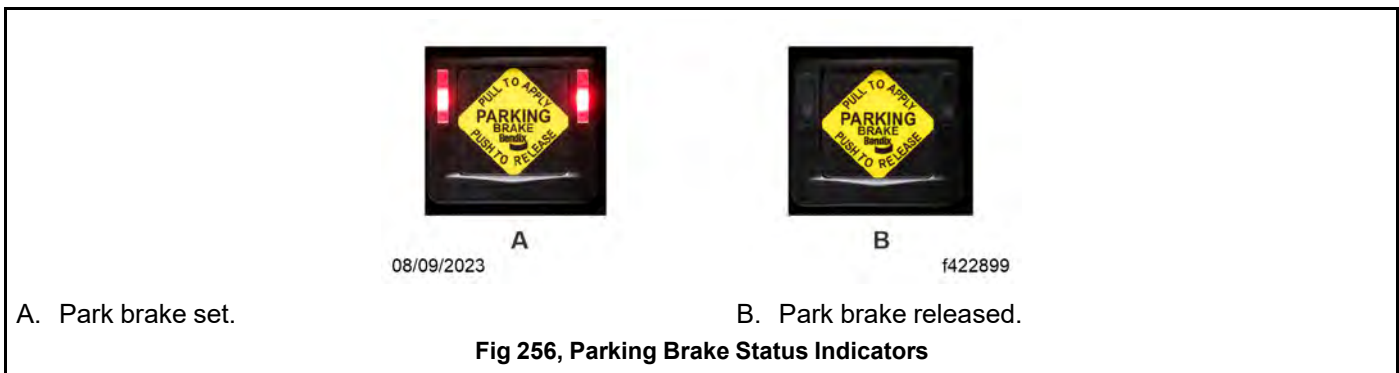
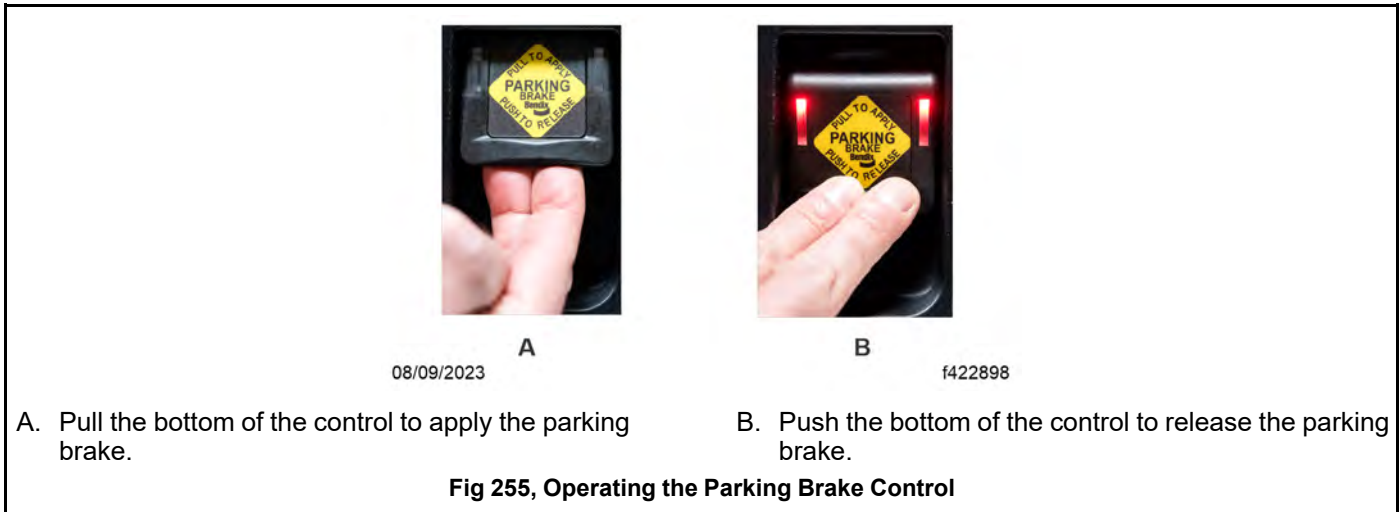

LEDs on the parking brake control extinguish when the parking brake is released. See Fig. 227, [Parking Brake Status Indicators](#).

12.06.05 Anti-Roll-Away Feature

The Intellipark anti-roll-away feature is intended to mitigate the possibility of a roll-away resulting from the driver failing to set the parking brake. Anti-roll-away automatically sets the parking brake within three seconds in the following circumstances.

- The engine is turned off and the park brake was not set prior.
- The vehicle is stationary, the accelerator pedal is not pressed, and the foot brake is not applied.
- The driver's door is opened and the speed is less than 3 mph (5 km/h).

Both LEDs in the yellow control blink continuously until the mitigation is acknowledged. To acknowledge, pull out on the bottom of the parking brake control.

IMPORTANT: The parking brake can not be released until the anti-roll-away mitigation has been acknowledged.

Release the parking brake by depressing the foot brake and pushing the bottom of the parking brake control. See Fig. 228, [Anti-Roll-Away Mitigation Acknowledgment Sequence](#) for the sequence of actions required.

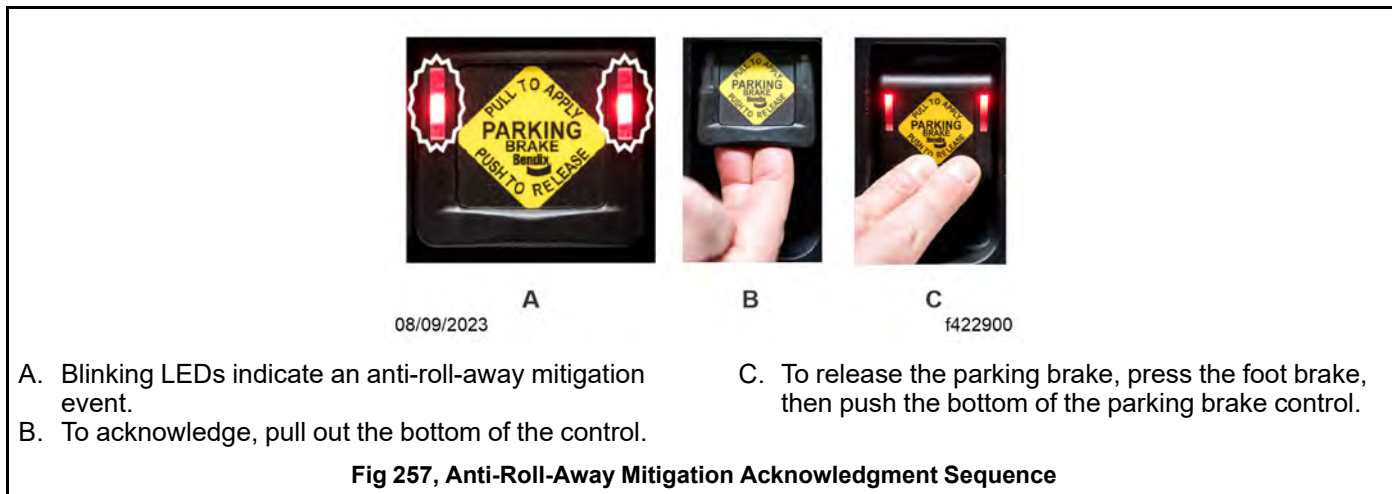

12.06.06 Exhaust-at-Speed



DANGER:

Never attempt to test the exhaust-at-speed feature or use it in the course of normal driving. This feature is intended for use only in emergency situations where the tractor and/or trailer service brakes are not available while driving. Testing can only be safely performed on a test track with a trained driver. Failure to follow this warning could lead to vehicle damage, property damage, injury, or death. Drivers and maintenance personnel must read and understand the contents of the Intellipark Owner's Manual before operating the vehicle.

In an emergency, the Intellipark system can be used to initiate a controlled stop of the vehicle if service brakes are not available. Pull and hold the bottom of the yellow parking brake control to slow and stop the vehicle. If the vehicle is towing a trailer, pull and hold the bottom of the red trailer air control switch at the same time to apply the spring brakes to the trailer. When the switches are released the parking and trailer spring brakes automatically release.

This feature has a short delay after the driver pulls the controls while the vehicle is in motion. The delay time increases with vehicle speed; at low speeds no delay is initiated. This function is intended to fulfill emergency braking operation while reducing the likelihood of unintended activations at normal on-road speeds.

12.06.07 Setting and Releasing the Parking Brakes on a Non-Towing Vehicle

Releasing the Parking Brakes on a Non-Towing Vehicle

1. Turn on the ignition.
2. Verify that the two LED displays illuminate, indicating that the spring brakes are set.
3. Close the driver and passenger doors.
4. Fasten the seat belt.
5. Apply the foot brake.
6. Start the engine and allow the system to build pressure to the governor cut-out.
7. Push the bottom of the yellow parking brake control.
8. Verify that the LED displays on the yellow parking brake control extinguish, then drive the vehicle.

12.06.08 Setting the Parking Brakes on a Non-Towing Vehicle

1. Bring the vehicle to a complete stop.
2. Continue to apply the foot brake.

3. Place the transmission in the appropriate gear.
4. Verify that all LEDs are extinguished.
5. Pull the bottom of the yellow parking brake control.
6. Verify that the LED displays illuminate, indicating that the spring brakes are set.

12.06.09 Towing Vehicle Combination Controls

The Intellipark system for a tractor-trailer combination has a yellow parking brake control, and a red trailer air supply control.

Towing Vehicle: Independent Trailer Operation

Intellipark allows the driver to set the trailer spring brakes independent of the towing vehicle. This feature allows operation of a towing vehicle as a bobtail, supports coupling and uncoupling operations, and allows trailer emergency braking control. Pulling the bottom of the red trailer air control applies the spring brakes on the trailer, with no change to the state of the towing vehicle. Pushing the bottom of the red trailer air control releases the spring brakes on the trailer, with no change to the towing vehicle.

Intellipark does not allow the trailer spring brakes to be released unless the ignition is on and the foot brake is applied. This feature is intended to mitigate the possibility of releasing the spring brakes on the trailer without a driver in control of the vehicle, while still allowing the trailer spring brakes to be released while the towing vehicle parking brake is set.

Bobtail Mode

Intellipark has a feature known as bobtail mode, that allows the driver to extinguish the two red LEDs on the trailer air supply control when driving without a trailer. To initiate, pull the bottom of the red trailer air supply control for a minimum of 3 seconds.

12.06.10 Releasing and Setting the Parking and Spring Brakes on a Tractor-Trailer Combination

When releasing the parking and spring brakes on a tractor-trailer combination it is necessary to release the tractor parking brake separately from releasing the spring brakes on the trailer. However, if Intellipark detects a situation where the driver has forgotten to release the trailer spring brakes and the vehicle is in motion, the spring brakes on the trailer automatically release.

12.06.11 Release the Parking Brake on the Tractor

1. Close the driver's and passenger's doors.
2. Fasten the seat belt.
3. Apply the foot brake.
4. Apply ignition power.
5. Verify that all LEDs on both controls illuminate and remain illuminated.
6. Start the engine, and allow the system to build pressure to governor cut-out.
7. Push the yellow parking brake control.
8. Verify that the LEDs on the yellow parking brake control extinguish.
9. Verify that the LEDs on the red trailer air control remain illuminated. See Fig. 229, **Tractor Parking Brake Released, and Trailer Spring Brakes Set**.



Fig 258, Tractor Parking Brake Released, and Trailer Spring Brakes Set

12.06.12 Release the Spring Brakes on the Trailer

1. Push the bottom of the red trailer air control.
2. Verify that the LEDs on the red trailer air control extinguish.
3. Verify that the LEDs on the yellow parking brake control remain extinguished. See Fig. 230, [Tractor Parking Brake Released and Trailer Spring Brakes Released](#).
4. Drive the vehicle and verify that all trailer wheels are free-rolling.



Fig 259, Tractor Parking Brake Released and Trailer Spring Brakes Released

12.06.13 Setting the Spring Brakes on a Tractor-Trailer Combination

Intellipark can set the spring brakes on a tractor-trailer with a single input. Pulling the yellow parking brake control sets the parking brake on the tractor and the spring brakes on the trailer.

1. Bring the vehicle to a complete stop.
2. Continue to apply the foot brake.
3. Place the transmission in the appropriate gear.
4. Verify that all LEDs are extinguished.
5. Pull the bottom of the yellow parking brake control.
6. Verify that all LEDs on both controls illuminate. See Fig. 231, [Tractor Parking Brake Set and Trailer Spring Brakes Set](#).



Fig 260, Tractor Parking Brake Set and Trailer Spring Brakes Set

12.06.14 System Faults



WARNING:

LEDs blinking, or one light illuminated on a control, indicate there is a problem or fault with the system. In some instances, the parking brake may be unavailable and the vehicle should NOT be driven. Failure to follow this instruction can result in personal injury and property damage.

See Fig.232., page 250 and see Table.26., page 250 for an interpretation of each LED illumination status.



08/22/2023

f422902

- 1. Left LED Trailer Air Supply Control
- 2. Right LED Trailer Air Supply Control
- 3. Left LED Parking Brake Control
- 4. Right LED Parking Brake Control

Fig 261, Towing Vehicle Controls

LED Illumination Key				
Left LED 1—Trailer Air Supply Control	Right LED 2—Trailer Air Supply Control	Left LED 3—Parking Brake Control	Right LED 4—Parking Brake Control	Status

Table 26, LED Illumination Key

ON	ON	ON	ON	All LEDs illuminate for 3 seconds when ignition is applied.
ON	ON	ON	ON	3 seconds after ignition is applied - both towing vehicle parking brake and trailer spring brakes are set.
OFF	OFF	OFF	OFF	3 seconds after ignition is applied - both towing vehicle parking brake and trailer spring brakes are released.
ON	ON	OFF	OFF	Trailer spring brakes are set. Towing vehicle park brakes are released.
ON	Blinking	ON	ON	A fault is present on the trailer spring brake system. Both the trailer spring brakes and the towing vehicle parking brakes are set.
OFF	Blinking	OFF	OFF	A fault is present on the trailer spring brake system. Both the trailer spring brakes and the towing vehicle parking brakes are released.
ON	ON	Blinking	ON	A fault is present on the towing vehicle park brake system. Both the trailer spring brakes and the towing vehicle parking brakes are set.
OFF	OFF	Blinking	OFF	A fault is present on the towing vehicle park brake system. Both the trailer spring brakes and the towing vehicle parking brakes are released.
OFF	Blinking	Blinking	OFF	An internal controller fault has been detected.

Table 26, LED Illumination Key

Blinking	Blinking	OFF	OFF	A fault with the trailer pressure sensor has been detected. Immediately chock the wheels and have the system serviced as soon as possible.
OFF	OFF	Blinking	Blinking	A fault with the towing vehicle pressure sensor has been detected. Immediately chock the wheel and have the system serviced as soon as possible.

Table 22, LED Illumination Key

12.06.15 Parking with a Fault

1. Stop on a level surface. Shut off the engine and open the driver-side window in order to hear air exhaust from the parking brakes.
2. Engage the parking brake by pulling the bottom of the parking brake control. Engage the trailer spring brakes by pulling on the bottom of the trailer air supply switch. Listen for air exhausting.
3. If the parking brake and trailer spring brakes did not engage, key off the vehicle and “fan down” the air reservoirs by repeatedly depressing the service brake pedal, until the parking brake and trailer spring brakes automatically set.
4. Turn off the battery power to the vehicle.
5. Chock the wheels.

12.06.16 Starting After a Fault

1. Start the engine.
2. Remain in the driver’s seat as the air brake system builds air, keeping the brake pedal depressed to ensure the vehicle remains stationary.
3. Once the system air is at a normal operating range remove the wheel chocks.
4. Release the parking brake by depressing the foot brake then pushing the bottom of the parking brake control, and the bottom of the trailer air supply control.

13.01 Steering System.....	254
13.01.01 General Information	254
13.01.02 Adjustment of the Steering Wheel	254

13. Steering System

13.01 Steering System

13.01.01 General Information

**WARNING:**

Driving the vehicle without the power-assist feature of the steering system requires much greater effort, especially in sharp turns or at low speeds, which could result in an accident and possible injury.

**NOTICE:**

Never steam clean or high-pressure wash the steering gear. Internal damage to gear seals, and ultimately the steering gear, can result.

**NOTICE:**

Avoid turning the tires when they are against a curb, as this places a heavy load on steering components and could damage them.

The power steering system includes the power steering gear, hydraulic hoses, power steering pump, reservoir, steering wheel and column, and other components.

Models equipped with dual steering are also equipped with a separate hydraulic power cylinder on the right side of the front axle or a right-hand secondary gear.

The power steering pump, driven by the engine, provides the power assist for the steering system. If the engine is not running, there is no power assist.

If the power-assist feature does not work due to hydraulic fluid loss, steering pump damage, or another cause, bring the vehicle to a safe stop. Do not drive the vehicle until the cause of the problem has been corrected.

Drivers should carefully use the power available with a power steering system. If the front tires become lodged in a deep hole or rut, drive the vehicle out instead of using the steering system to lift the tires out of the hole.

13.01.02 Adjustment of the Steering Wheel

When there is no load on the vehicle and the front tires are pointed straight ahead, the standard steering wheel spokes should be at the 3 o'clock and 9 o'clock positions or within 10 degrees of these positions. See Fig. 233, [Steering Wheel Centered](#).

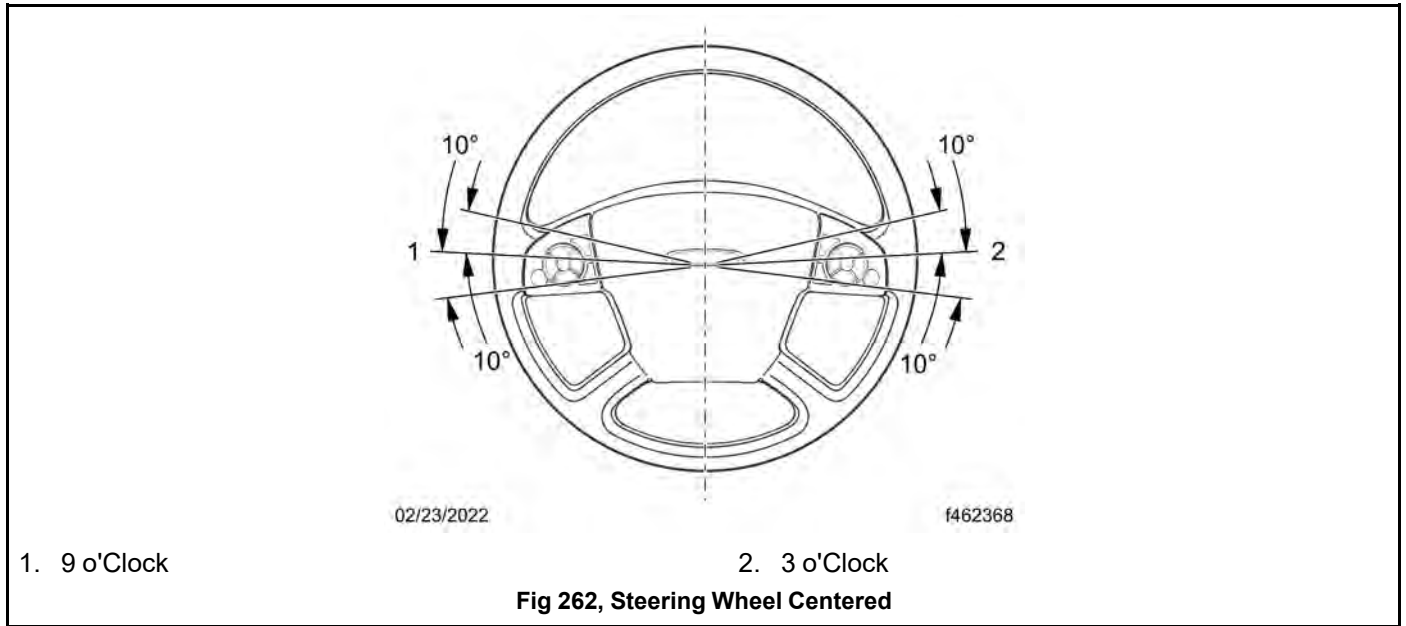

If the steering wheel is not in the position above when checked, take the vehicle to an authorized Freightliner dealership to have the steering adjusted.

14.01 Greenhouse Gas Emissions and Fuel Consumption Standards.....	258
14.02 EPA-Regulated Emissions Aftertreatment Systems.....	258
14.02.01 General Information	258
14.02.02 Euro V Emission Compliant Engines for Export	259
14.02.03 EPA10 and Newer Engines	259
14.02.04 Regeneration.....	259
14.02.05 Regen Operations.....	260
14.02.06 ATS Warning Lamps and Messages	262
14.02.07 Maintenance.....	268
14.03 Diesel Exhaust Fluid and Tank.....	268
14.03.01 Diesel Exhaust Fluid.....	268
14.03.02 DEF Tank	268
14.03.03 Fuel/DEF Gauge.....	268
14.03.04 DEF Warnings and Engine Limits	269

14. Emissions

14.01 Greenhouse Gas Emissions and Fuel Consumption Standards

Model year 2007 and later vehicles and/or engines domiciled in the U.S. or Canada are designed to meet Emission and Fuel Efficiency Standards of the U.S. (Federal) Environmental Protection Agency (EPA), the National Highway Traffic Safety Administration (NHTSA), Emission Regulations under the Canada Motor Vehicle Safety Act in Canada, and the California Air Resources Board (CARB) effective as per the applicable emission model year. See Table.27, [EPA Regulations](#) and see Fig.28, [Emission Regulations by Model Year](#) for EPA regulations. To determine an engine's or vehicle's emission model year, refer to the respective EPA/CARB certification label.

EPA Regulations	
Regulation	Emissions Components
EPA10 (Reduction of NOx emissions to 0.2 g/bhp-hr)	EPA07-type ATD, with additional selective catalyst reduction (SCR) technology that utilizes diesel exhaust fluid (DEF) to convert NOx to nitrogen and water vapor.
GHG21	GHG14/17 components plus additional components including, but not limited to, transmissions, axles, predictive technologies, idle reduction technologies for vocational vehicles, tire pressure monitoring systems.

Emission Regulations by Model Year		
Model Year	Engine Regulation	GHG Regulation
2021–and later	EPA10, GHG21	GHG21

14.02 EPA-Regulated Emissions Aftertreatment Systems

14.02.01 General Information



NOTICE:

Follow these guidelines for engines that comply with EPA07 or newer regulations, or damage may occur to the Aftertreatment System (ATS) and the warranty may be compromised.

Use ultralow-sulfur diesel with 15 ppm sulfur content or less.

Do not use fuel blended with used engine lube oil or kerosene.

Use only approved engine lube oil. For lists of engine oils approved for Detroit Diesel engines, refer to the Engine Operator Manual, accessible on Lubricants, Fuels & Coolants on the DTNA Portal. For third party engines, please refer to the engine manual.

IMPORTANT: Using non-specification fuels or oils can lead to shortened diesel particulate filter (DPF) cleaning or replacement intervals.

IMPORTANT: See the engine manufacturer's operation manual for complete details and operation of the ATS.

14.02.02 Euro V Emission Compliant Engines for Export

IMPORTANT: Depending on local jurisdictional guidelines, vehicles that are domiciled outside of the U.S. and Canada may not have emissions aftertreatment systems (ATS) that are compliant with EPA regulations.

Vehicles sold with Euro V engines for export are required to use diesel with a maximum sulfur content as follows:

- Cummins Engines 50 ppm (tolerant to 500 ppm)
- Detroit Engines 50 ppm

See Fig.234, [Euro V Engine Label \(Detroit engine label shown\)](#) for an example of the label.



Fig 263, Euro V Engine Label (Detroit engine label shown)

(Use diesel with a maximum sulfur content of 50 ppm)

14.02.03 EPA10 and Newer Engines

The EPA mandates that all engines built after December 31, 2009 must reduce the level of emissions exhausted by the engine to the following levels:

- Nitrogen Oxides (NOx) – 0.2 g/bhp-hr
- Particulate Matter (PM) – .01 g/bhp-hr

To meet EPA guidelines, engines that are compliant with EPA10 and newer regulations use an ATS where the exhaust first passes over the diesel oxidation catalyst (DOC), then passes through the diesel particulate filter (DPF), which traps soot particles. The soot is burned to ash during a process called regeneration (regen). A Selective Catalytic Reduction (SCR) device is used to reduce NOx downstream of the engine. After exhaust gases leave the DPF, a controlled quantity of diesel exhaust fluid (DEF) is injected into the exhaust stream. In the presence of heat, DEF is converted to ammonia gas, which reacts with NOx in the selective catalyst chamber to yield nitrogen and water vapor, which exit through the tailpipe.

14.02.04 Regeneration

The harder an engine works, the better it disposes of soot. If the exhaust temperature is high enough, a process called **passive regeneration** (regen) occurs as the vehicle is driven normally. However, if the engine isn't running hot enough, the electronic controls may initiate an **active regen**, whereby extra fuel is injected into the exhaust stream to superheat and reduce the soot trapped in the DPF to ash. Active regen happens only when the vehicle is moving above a certain speed, determined by the engine manufacturer. See your engine operation manual for complete details. Both active and passive regen happen automatically, without driver input.



WARNING:

Active regeneration can occur automatically anytime the vehicle is moving. The exhaust gas temperature could reach 1500°F (800°C), which is hot enough to cause a fire, heat damage to objects or materials, or personal injury to persons near the exhaust outlet. The exhaust temperature can remain high even after the vehicle has stopped. When stopping the vehicle shortly after an automatic regen, ensure the exhaust outlets are directed away from structures, vegetation, flammable materials, and anything else that may be harmed by exposure to high heat.

See **Regen Operations** , below, for instructions on preventing automatic regen if necessary.

When operating conditions do not allow for ATD filter cleaning by active or passive regen, the vehicle may require a driver-activated **parked regen** . When this occurs, the driver display screen presents a message indicating that a regen is required. See Fig.235,**Parked Regen Message Screens**. The driver must either bring the vehicle up to highway speed to increase the load (thus starting an active regen), or park the vehicle and initiate a parked regen. See **Regen Operations** , below, for instructions on initiating a parked regen.

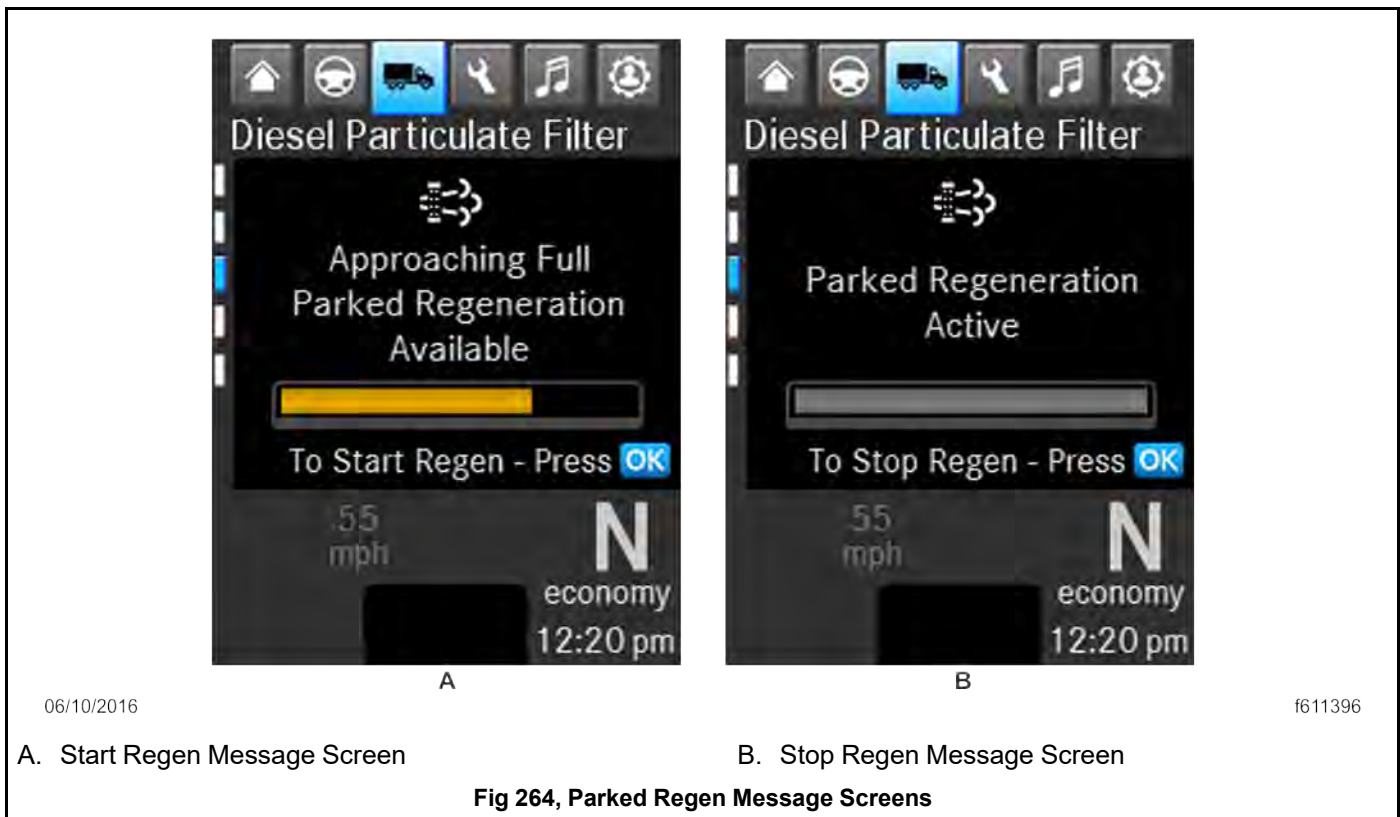

14.02.05 Regen Operations

Parked regen is initiated by selecting OK when the driver display screen shows 'Parked Regen Required.' See Fig. 237,**Parked Regen Message Screens**. If the vehicle is equipped with the optional digital STOP REGEN switch, parked regen can be stopped by pressing OK on the screen while the regen is in progress. See Fig. 237,**Parked Regen Message Screens**.

Some vehicles may be equipped with a REGEN OFF physical switch. See Fig.236,**Regen OFF Switch**. To stop a regen in progress or prevent the start of a regen, press the lower half of the switch. Regen is then delayed until the switch is no longer active.

NOTE: Parked regen can be initiated only when the DPF lamp is illuminated.

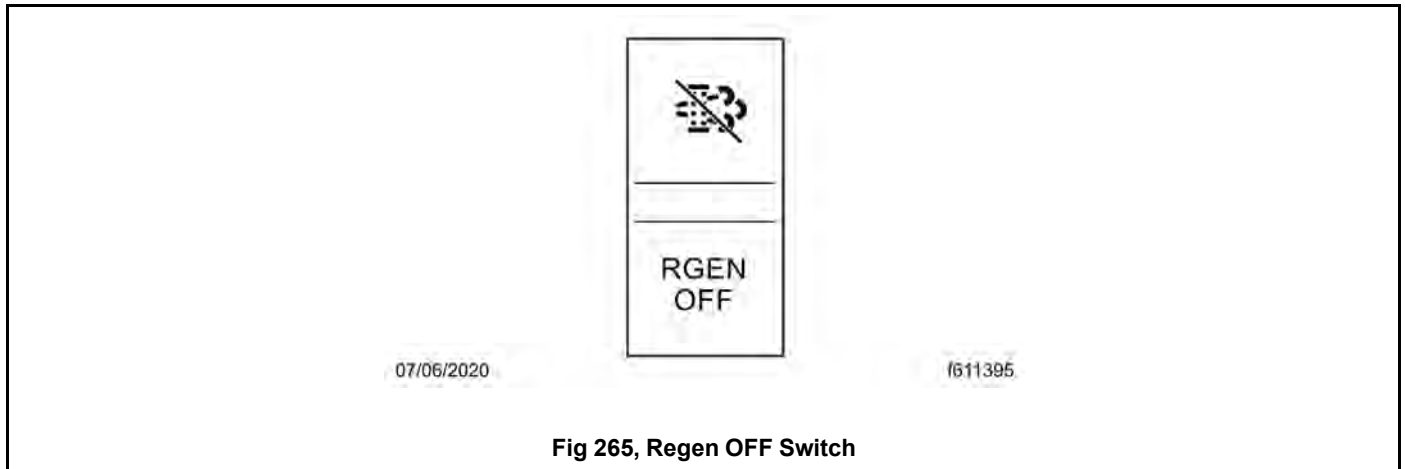

Fig 265, Regen OFF Switch

**WARNING:**

During parked regen, exhaust temperatures are very high and could cause a fire, heat damage to objects or materials, or personal injury to persons near the exhaust outlet.

Before initiating a parked regeneration, make certain the exhaust outlets are directed away from structures, vegetation, flammable materials, and anything else that may be harmed by prolonged exposure to high heat.

To initiate a parked regen, perform the following steps.

1. Park the vehicle away from all flammable materials, put the transmission in neutral, and set the parking brake.
2. Start and warm the engine until the coolant temperature is at least 150°F (66°C).
3. Select OK when the DPF screen is displayed on the driver display screen. See Fig. 237, [Parked Regen Message Screens](#). Select OK again to confirm regen. As the regen process is initiated, engine rpm increases and the HEST lamp illuminates to indicate extremely high exhaust temperatures.

IMPORTANT: The driver is responsible for ensuring, during the entire regen cycle, that anything that could be harmed by exposure to high heat does not come in contact with the exhaust gases flowing from the outlets.

4. The regen cycle finishes after 20 to 60 minutes, at which time engine idle speed drops to normal and the vehicle can be driven normally. The HEST lamp is extinguished when vehicle speed exceeds 5 mph (8 km/h) or the system has cooled to normal operating temperature.
5. To stop a parked regen at any time during the process:
 - depress the clutch pedal, brake pedal, or accelerator pedal;
 - select OK on the parked regen screen while the regen is active, then select OK again to confirm;
 - press and hold the regen inhibit switch until idle returns to normal;
 - shut down the engine.

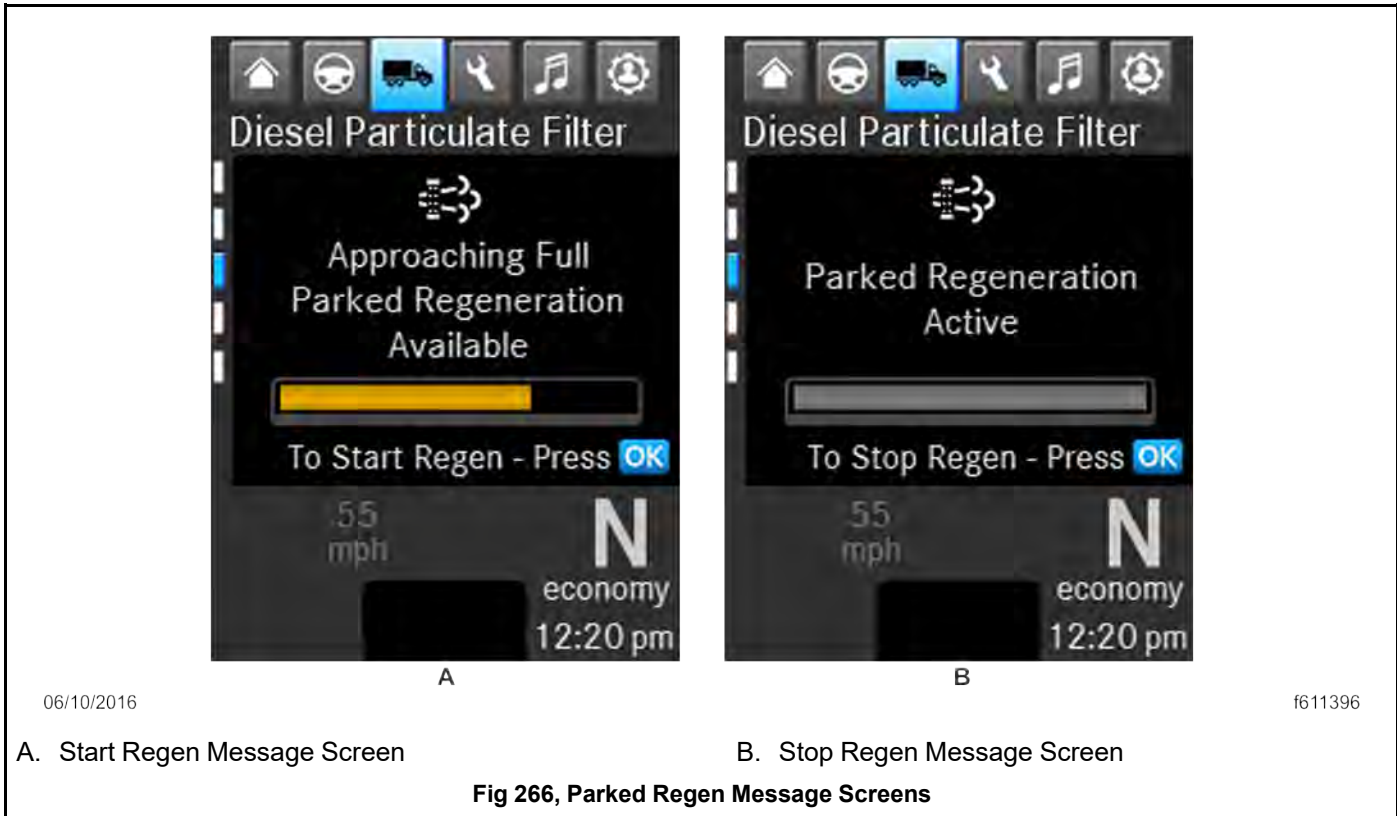

14.02.06 ATS Warning Lamps and Messages

There are three warning lamps that alert the driver of high exhaust temperature, the need to perform a parked regen or service the DPF, or of an engine fault that affects emissions. A decal attached to the driver's sun visor explains the ATS warning lamps.

Malfunction Indicator Lamp (MIL)

A steadily illuminated yellow malfunction indicator lamp (MIL) indicates an engine fault that affects emissions. See Fig. 238, [Malfunction Indicator Lamp \(MIL\)](#).

DPF Status Lamp and Messages

When soot accumulates in the DPF, the driver display screen presents a DPF status bar. As the soot level in the DPF reaches 60 percent, the DPF status lamp illuminates. See Fig. 239, [DPF Status Lamp](#). Perform a parked regen or bring the vehicle up to highway speed to increase the load (thus starting an active regen). After the soot level in the DPF reaches 80 percent, a parked regen is necessary.

For an explanation of DPF zones, message screens, warning lamps, and available regen modes, see Table.29, [DPF Zones, Detroit Engines](#). (Detroit engines) or See Table.30, [DPF Zones, Cummins Engines](#). (Cummins engines).

If the DPF status lamp blinks and the driver display screen shows a red status bar (90 percent full), initiate a parked regen immediately in order to prevent an engine derate.

If the DPF status lamp blinks, and the driver display screen shows a DPF status bar that is fully red (100 percent full), begin a parked regen in order to prevent an engine shutdown. Park the vehicle and perform a parked regen.

DPF Zones, Detroit Engines			
DPF Zone	DPF Status Bar	Warning Lamps	Regen Mode Available
0	 <p>Fig 267,</p> <p>0–10% Green</p>	—	<ul style="list-style-type: none"> • passive
1	 <p>Fig 268,</p> <p>10–60% Green</p>	—	<ul style="list-style-type: none"> • over-the-road

Table 29, DPF Zones, Detroit Engines

<p>2</p>	 <p>Fig 269,</p> <p>60–70% Yellow</p>	 <p>Fig 270,</p> <p>DPF solid yellow</p>  <p>Fig 271,</p> <p>HEST solid yellow*</p>	<ul style="list-style-type: none"> • over-the-road • parked
<p>3</p>	 <p>Fig 272,</p> <p>70–80% Yellow</p>	 <p>Fig 273,</p> <p>DPF flashing yellow</p>  <p>Fig 274,</p> <p>HEST solid yellow*</p>	<ul style="list-style-type: none"> • over-the-road • parked

Table 29, DPF Zones, Detroit Engines

<p>4</p>	 <p>Fig 275,</p> <p>80–90% Red</p>	 <p>Fig 276,</p> <p>DPF flashing yellow</p>  <p>Fig 277,</p> <p>HEST solid yellow*</p>	<p>• parked</p>
<p>5</p>	 <p>Fig 278,</p> <p>90–100% Red</p>	 <p>Fig 279,</p> <p>DPF flashing yellow</p>  <p>Fig 280,</p> <p>HEST solid yellow*</p>	<p>• parked</p>

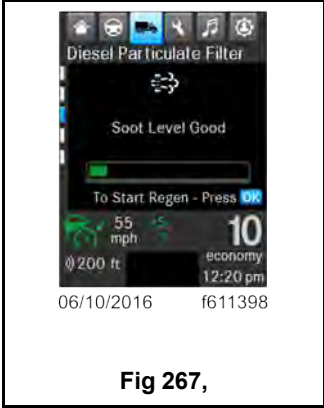
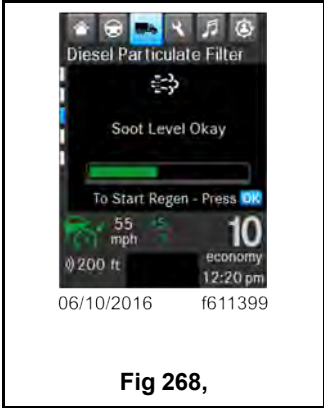
Table 23, DPF Zones, Detroit Engines

* Illuminates if exhaust temperature is above a preset limit.

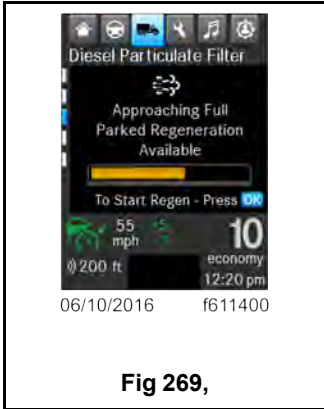
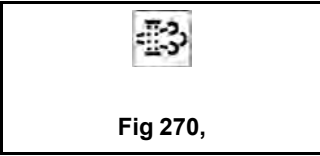
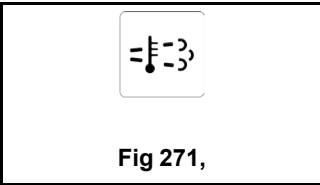
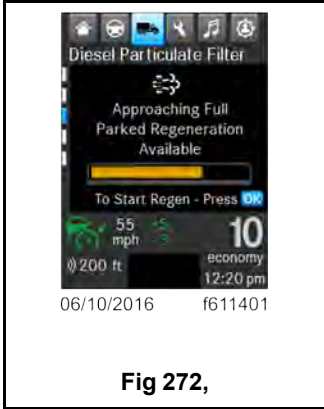
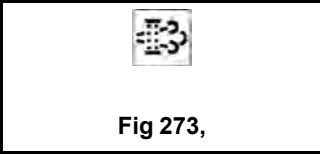
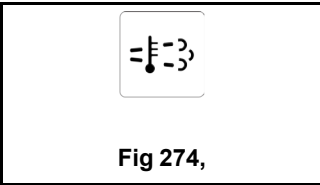
DPF Zones, Cummins Engines			
DPF Zone	DPF Status Bar	Warning Lamps	Regen Mode Available

Table 30, DPF Zones, Cummins Engines

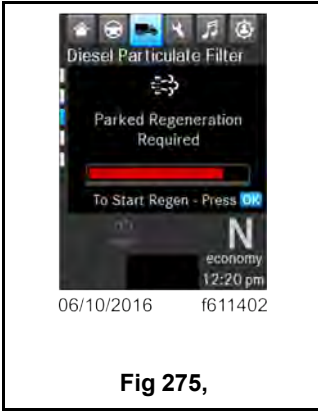
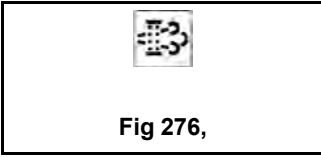
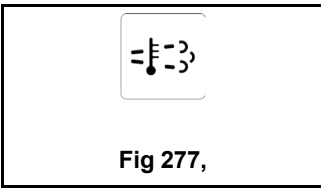
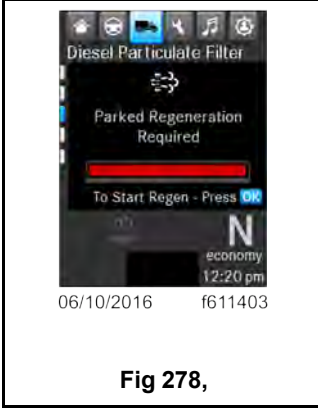
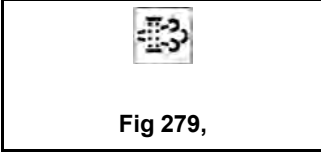
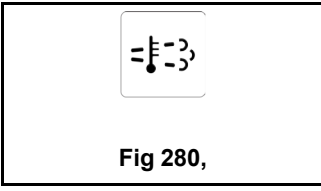



<p>1</p>	 <p>Fig 281,</p> <p>0–60% Green</p>	<p>—</p>	<ul style="list-style-type: none"> • over-the-road
<p>3</p>	 <p>Fig 282,</p> <p>60–80% Yellow</p>	 <p>Fig 283,</p> <p>DPF flashing yellow</p>  <p>Fig 284,</p> <p>HEST solid yellow*</p>	<ul style="list-style-type: none"> • over-the-road • parked
<p>5</p>		 <p>Fig 286,</p> <p>DPF flashing yellow</p>	<ul style="list-style-type: none"> • parked

Table 30, DPF Zones, Cummins Engines

	<p>Fig 285,</p> <p>80–100% Red</p>	 <p>Fig 287,</p> <p>HEST solid yellow</p>	
--	---	--	--

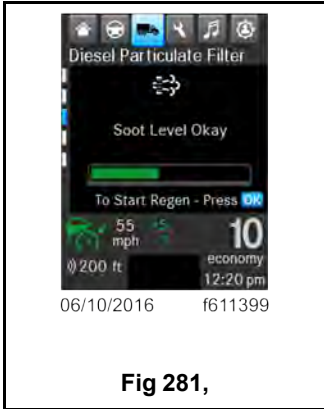
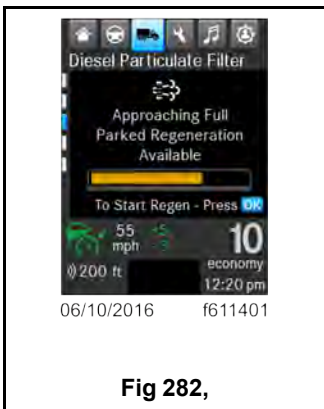
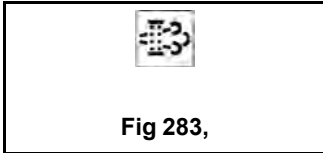
Table 24, DPF Zones, Cummins Engines

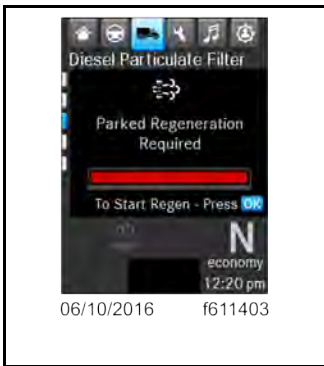
* Illuminates if exhaust temperature is above a preset limit.

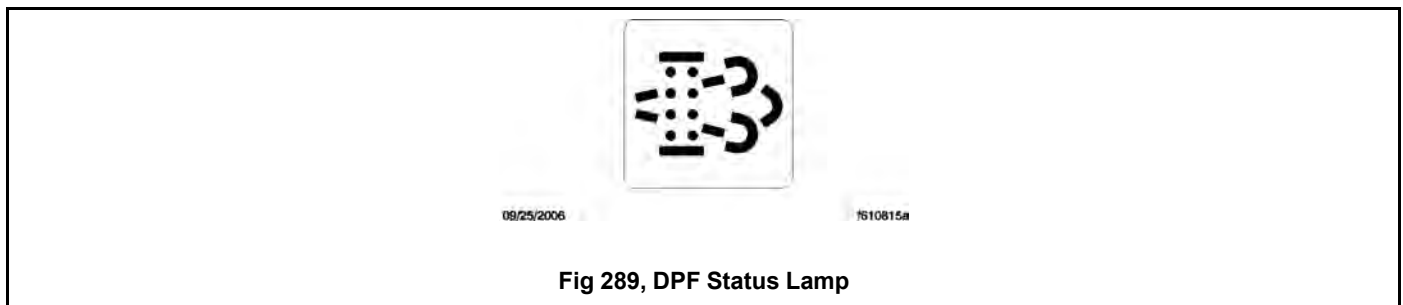
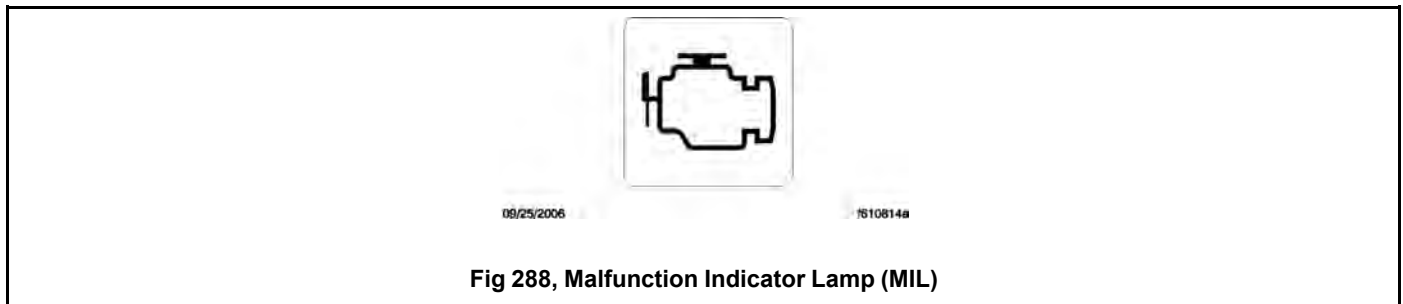

High Exhaust System Temperature (HEST) Lamp

Slow (10-second) flashing of the high exhaust system temperature (HEST) lamp indicates that a parked regen is in progress, and the engine’s high idle speed is being controlled by the engine software, not the vehicle driver.

Steady illumination of the HEST lamp alerts the driver of high exhaust temperature during the regen process if the vehicle speed is below 5 mph (8 km/h), or during a parked regen. See Fig.240, [HEST Lamp](#).

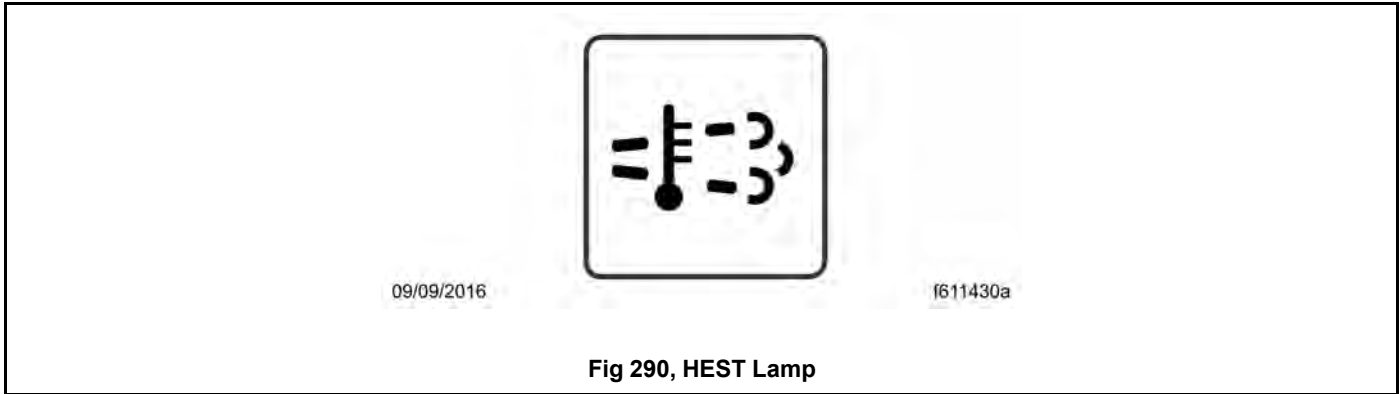

14.02.07 Maintenance

Authorized service facilities must perform any DPF service. For warranty purposes, maintain a record that includes:

- date of cleaning or replacement;
- vehicle mileage;
- particulate filter part number and serial number.

14.03 Diesel Exhaust Fluid and Tank

14.03.01 Diesel Exhaust Fluid

Diesel exhaust fluid (DEF) is used in the ATS to lower NOx in the exhaust stream. DEF is colorless and close to odorless (it may have a slightly pungent odor similar to ammonia). It is nontoxic, nonflammable, and biodegradable. It is mildly corrosive to aluminum, but does not affect the strength or structure of the aluminum.

White crystals may be noticeable around components that come into contact with DEF. The crystals are easily removed with water.

DEF consumption varies depending on ambient conditions and vehicle application.

Freezing Conditions

DEF freezes to slush at around 12°F (-11°C). It is not damaged or destroyed if frozen, and is fully usable when thawed. The DEF in the tank is allowed to freeze while a vehicle is non-operational. At start-up, normal operation of the vehicle is not inhibited if the DEF is frozen; an immersion heater with engine coolant flowing through it warms the DEF once the engine is running, allowing the SCR system to operate.

14.03.02 DEF Tank

Engines that are compliant with EPA10 and newer regulations are equipped with a DEF tank located on the driver's side of the vehicle behind the battery box or forward of the fuel tank. The DEF tank has a 19 mm filler neck inlet that prevents the hose from a diesel outlet from being inserted, and has a blue cap for easy identification.

14.03.03 Fuel/DEF Gauge

The diesel fuel and DEF levels are measured in a dual-purpose gauge. Below the gauge, a low fuel warning lamp illuminates amber when the fuel level drops below 1/8th of the capacity. See Fig.241, [Fuel/DEF Gauge](#).

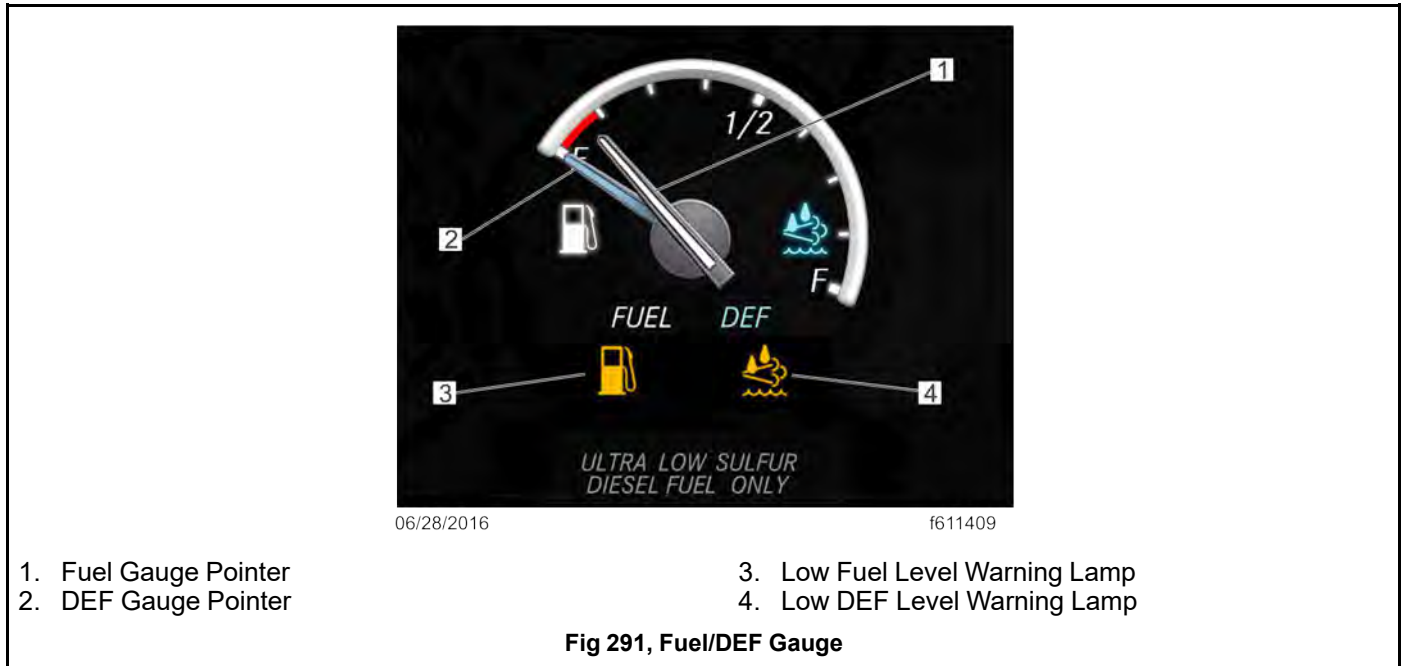

A DEF warning lamp illuminates amber when the DEF tank is near empty.

14.03.04 DEF Warnings and Engine Limits

IMPORTANT: Ignoring the DEF low level warnings results in limited engine power, with the application of a 5 mph (8 km/h) speed limit.

DEF Level Low—Initial Warning

When the DEF level is low, the DEF warning lamp illuminates solid amber, and the driver display screen presents an alert. See Fig.242, [DEF Level Messages](#). Refill the DEF tank in order to cancel the warning sequence.

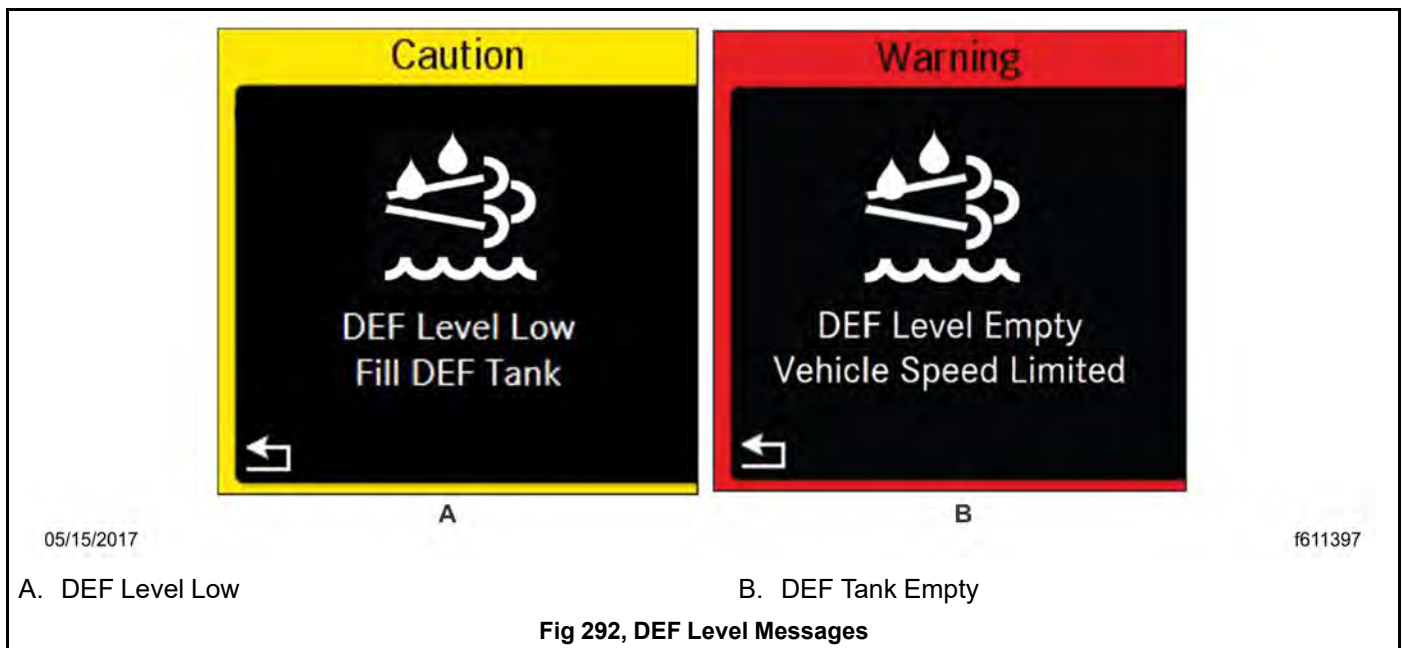

DEF Empty

When the DEF level reads empty, the following lamps and messages notify the driver.

- The DEF warning lamp flashes amber.
- The MIL lamp illuminates.
- The driver display screen presents the warning, 'DEF Tank Empty.' See Fig.242, [DEF Level Messages](#).

Power is limited with progressively harsher engine power limits applied.

DEF Tank Empty and Ignored

If the empty warning is ignored and the DEF tank is not refilled, the red STOP engine lamp illuminates in addition to the MIL lamp and CHECK engine lamp (on vehicles with a Cummins ISB or ISC/L engine).

If the DEF is not refilled, a 5 mph (8 km/h) speed limit is applied after the next engine shutdown, while parked and idling, or if a fuel refill is detected.

DEF Contamination or SCR Tampering

**NOTICE:**

Once contaminated DEF or tampering has been detected, the vehicle must be taken to an authorized service facility to check the SCR system for damage and to deactivate the warning lights and engine limits.

If contaminated DEF or tampering with the ATS is detected, the DEF warning light flashes and the MIL lamp illuminates to warn the driver. The CHECK engine lamp also illuminates on vehicles with a Cummins ISB or ISC/L engine.

- Detroit engines: Engine power is limited with progressively harsher limits applied. If the fault is not corrected, the STOP engine light illuminates and a 5 mph (8 km/h) speed limit is applied after the next engine shutdown, while parked and idling, or if a fuel refill is detected.
- Cummins engines: Engine power is limited with progressively harsher limits applied. If the fault is not corrected, the STOP engine light illuminates and a 5 mph (8 km/h) speed limit is applied after the next engine shutdown, or while parked and idling.

15.01 Automated/Automatic Transmission Shift Control.....	273
15.01.01 Direction Switch.....	273
15.01.02 Mode Switch.....	276
15.01.03 Gear Switch.....	276
15.01.04 Engine Brake.....	279
15.01.05 Power Up and Shift into Gear.....	279
15.01.06 Gear Display.....	279
15.01.07 Selected Gear (Detroit and Eaton Transmissions).....	280
15.01.08 Suggested Shift (Detroit and Eaton Transmissions).....	280
15.02 Detroit™ Automated Transmissions (DT12).....	280
15.02.01 General Information.....	280
15.02.02 Driving Modes.....	280
15.02.03 eCoast.....	281
15.02.04 Creep Mode.....	283
15.02.05 Hill Start Aid (HSA).....	284
15.02.06 Clutch Abuse Protection.....	284
15.02.07 Engine Overspeed Alerts.....	285
15.02.08 Descent Control Mode.....	285
15.02.09 Hill Descent Upshift Feature.....	286
15.02.10 Transmission Low Air Warning.....	287
15.02.11 Clutch Abuse Alerts and Protections.....	288
15.02.12 Auto Neutral.....	288
15.03 Eaton™ Automated Transmissions.....	289
15.03.01 Multi-Function Stalk Switch.....	289
15.03.02 Push-Button Shift Selector.....	291
15.03.03 Clutch Abuse Protection.....	293
15.03.04 Creep Mode.....	294
15.03.05 Engaging Creep Mode.....	294
15.03.06 Exiting Creep Mode.....	294
15.03.07 Hill Start Aid.....	294
15.03.08 Engine Overspeed Protection.....	294

15.03.09 Shuttle Shifting	295
15.03.10 Auto Start Gear Selection and Override	295
15.03.11 Skip Shifting.....	295
15.03.12 Auto Neutral	295
15.03.13 Automatic Traction Control.....	295
15.03.14 Load-Based Shifting.....	295
15.03.15 Coasting.....	295
15.03.16 Transmission Low Air Warning	295
15.03.17 Transmission Prognostics.....	296
15.04 Allison Automatic Transmissions	297
15.04.01 General Information, Allison Transmissions.....	297
15.04.02 Operation Tips, Allison Transmissions	298
15.04.03 Automatic Mode (A)	299
15.04.04 Manual Mode (M).....	299
15.04.05 Low (L).....	300
15.04.06 Transmission Prognostics	300
15.05 Allison On-Highway Transmissions.....	301
15.05.01 Safety Precautions	301
15.05.02 Without Park Position	301
15.05.03 With Park Position.....	301
15.05.04 2000 Series	302
15.05.05 Without Auto-Apply Parking Brake.....	302
15.05.06 With Auto-Apply Parking Brake	302
15.05.07 2400 Series	302
15.05.08 Range Inhibit Indicator, 2000 and 2400 Series.....	302
15.05.09 Operating Instructions, On-Highway Transmissions.....	302
15.06 Allison Transmission® MD Series	304
15.06.01 Safety Precautions	304
15.06.02 Operating Instructions, MD Series	305

15. Automated and Automatic Transmissions

15.01 Automated/Automatic Transmission Shift Control

15.01.01 Direction Switch

Vehicles with automated or automatic transmissions use the multifunction stalk switch control shown in Fig. 243, [Automated/Automatic Transmission Shift Control](#) and see Fig. 244, [Engine Brake Positions](#). This control can be used to request manual shifts, change driving mode, and set engine brake levels. See Table.31, [Functionality, Automated/Automatic Transmission Shift Control](#) for an overview of control functionality.

Use the direction switch to request drive (D), neutral (N), or reverse (R). See Fig. 243, [Automated/Automatic Transmission Shift Control](#), Ref. A.

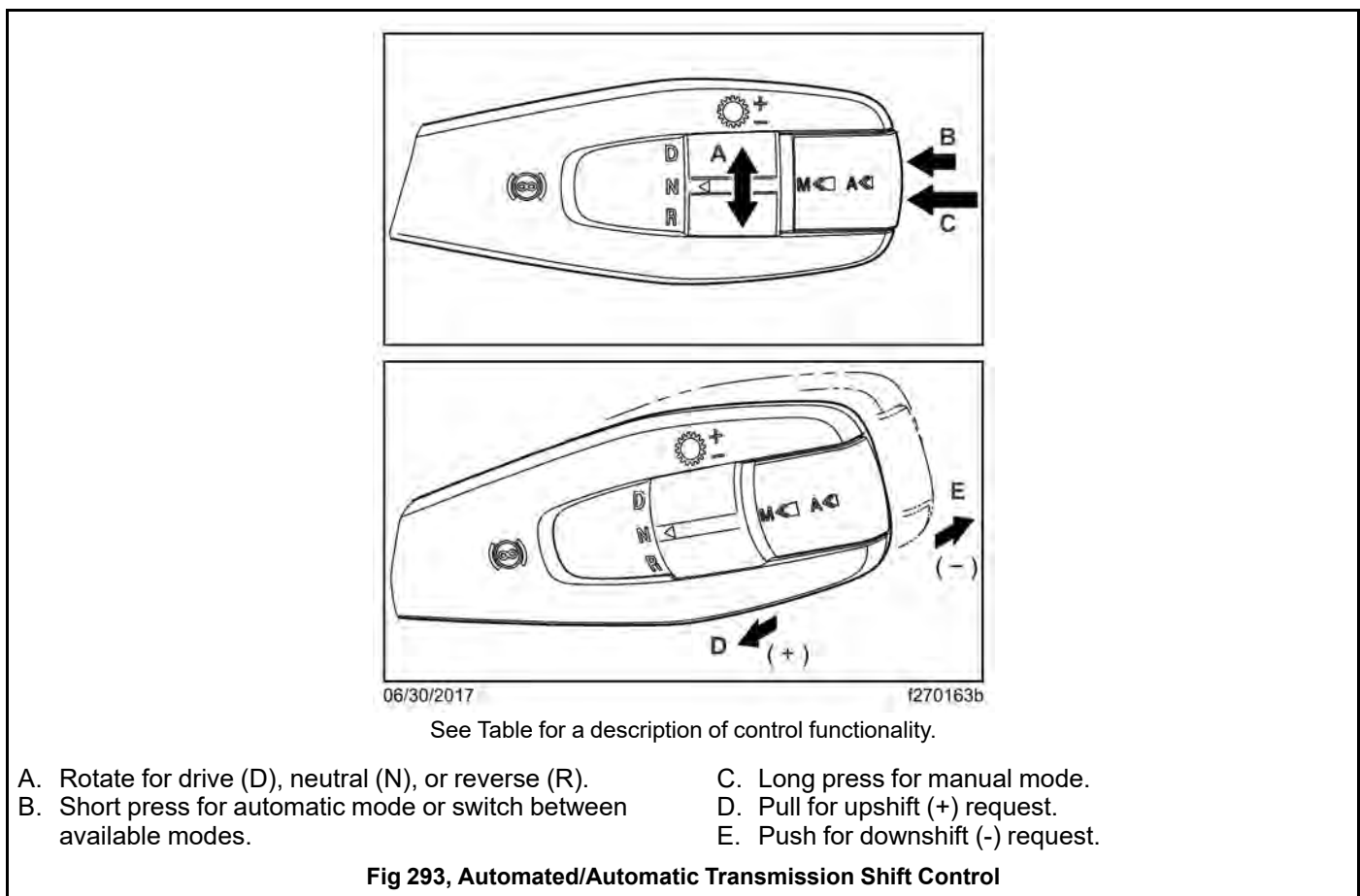

See Table for a description of control functionality.

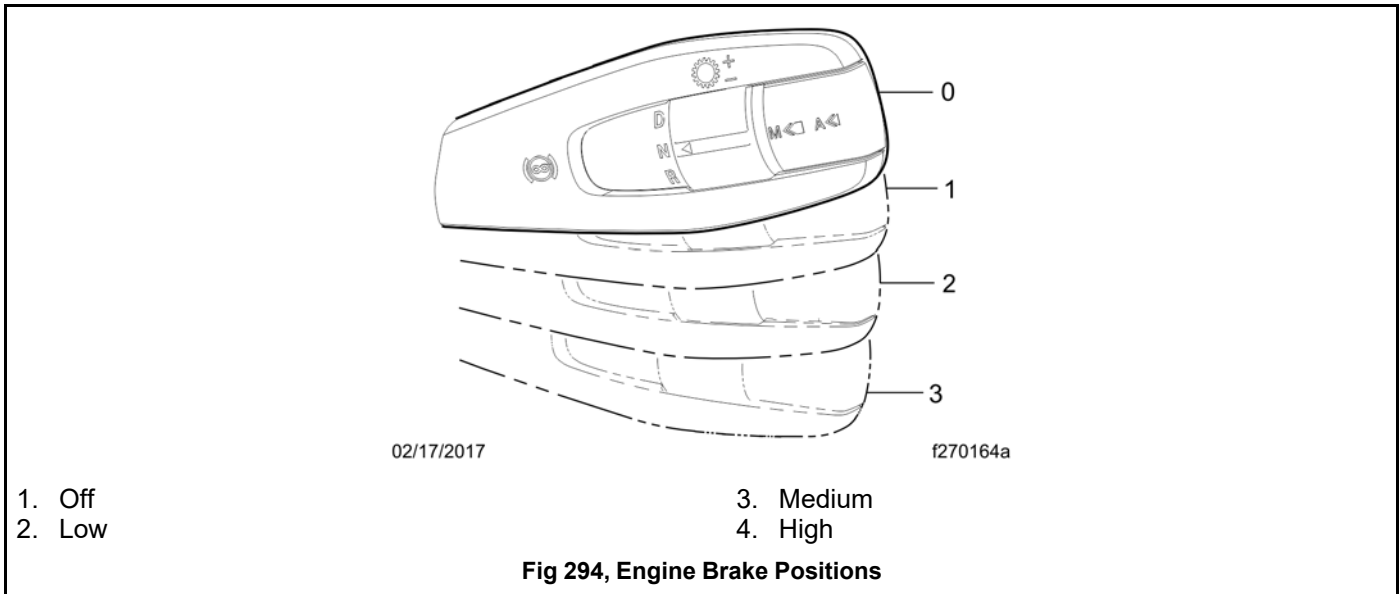

Functionality, Automated/Automatic Transmission Shift Control		
Function/Switch	Action/Position	Request
Direction	All Transmissions	
	D	Forward gears
	N	Neutral
	R	Reverse gears
Mode	Short press	Detroit and Eaton: Activate the automatic drive mode, or switch between available modes Allison: Switch between available shift modes.
	Long press	Detroit and Eaton: Activate the manual drive mode (if available) Allison: Switch between automatic and manual drive mode.
Gear (Detroit Automated Transmissions)	Detroit Automated Transmissions	
	Short pull on the lever	Upshift, single gear
	Pull on the lever in quick repetitions	Upshift, multiple gears
	Short push on the lever	Downshift, single gear
	Push on the lever in quick repetitions	Downshift, multiple gears

Table 31, Functionality, Automated/Automatic Transmission Shift Control

Gear (Eaton Automated Transmissions)	Eaton Automated Transmissions	
	Short pull on the lever	Upshift, single gear
	Pull on the lever in quick repetitions	Upshift, multiple gears
	Short push on the lever	Downshift, single gear
	Push on the lever in quick repetitions	Downshift, multiple gears
	While in automatic drive mode, long push on the lever	Downshift to low mode
	While in low mode, pull on the lever	Exits low mode and returns to automatic drive mode
	While in reverse mode, push on the lever	Selects deep reverse gear
	While in deep reverse gear, pull on the lever	Upshifts to standard reverse gear
Gear (Allison Automatic Transmissions)	Allison Automatic Transmissions	
	Short pull on the lever	Upshift, single gear
	Pull on the lever in quick repetitions	Upshift, multiple gears
	Short push on the lever	Downshift, single gear
	Push on the lever in quick repetitions	Downshift, multiple gears
	While in automatic drive mode, long push on the lever	Downshift to low mode
	While in low mode, pull on the lever	Exits low mode and returns to automatic drive mode
	While in reverse mode, push on the lever	Selects deep reverse gear (only on 7-speed 4000 Series transmissions)
	While in deep reverse gear (only on 7-speed 4000 Series transmissions), pull on the lever	Upshifts to standard reverse gear
Engine Brake*	Engine Brake Functions	
	Lever at position 0 (top)	Engine brake off
	Lever at position 1	Low intensity
	Lever at position 2	Medium intensity
	Lever at position 3 (bottom)	High intensity

Table 25, Functionality, Automated/Automatic Transmission Shift Control

* For functions with cruise control active, see [8.01.01 General Description, Standard Adaptive Cruise Control](#).

	N	Neutral
	R	Reverse gears
Mode	Short press	Detroit and Eaton: Activate the automatic drive mode, or switch between available modes Allison: Switch between available shift modes.
	Long press	Detroit and Eaton: Activate the manual drive mode (if available) Allison: Switch between automatic and manual drive mode.
Gear (Detroit Automated Transmissions)	Detroit Automated Transmissions	
	Short pull on the lever	Upshift, single gear
	Pull on the lever in quick repetitions	Upshift, multiple gears
	Short push on the lever	Downshift, single gear
	Push on the lever in quick repetitions	Downshift, multiple gears
Gear (Eaton Automated Transmissions)	Eaton Automated Transmissions	
	Short pull on the lever	Upshift, single gear
	Pull on the lever in quick repetitions	Upshift, multiple gears
	Short push on the lever	Downshift, single gear
	Push on the lever in quick repetitions	Downshift, multiple gears
	While in automatic drive mode, long push on the lever	Downshift to low mode
	While in low mode, pull on the lever	Exits low mode and returns to automatic drive mode
	While in reverse mode, push on the lever	Selects deep reverse gear
	While in deep reverse gear, pull on the lever	Upshifts to standard reverse gear
Gear (Allison Automatic Transmissions)	Allison Automatic Transmissions	
	Short pull on the lever	Upshift, single gear
	Pull on the lever in quick repetitions	Upshift, multiple gears
	Short push on the lever	Downshift, single gear
	Push on the lever in quick repetitions	Downshift, multiple gears

Table 32, Functionality, Automated/Automatic Transmission Shift Control

	While in automatic drive mode, long push on the lever	Downshift to low mode
	While in low mode, pull on the lever	Exits low mode and returns to automatic drive mode
	While in reverse mode, push on the lever	Selects deep reverse gear (only on 7-speed 4000 Series transmissions)
	While in deep reverse gear (only on 7-speed 4000 Series transmissions), pull on the lever	Upshifts to standard reverse gear
Engine Brake*	Engine Brake Functions	
	Lever at position 0 (top)	Engine brake off
	Lever at position 1	Low intensity
	Lever at position 2	Medium intensity
	Lever at position 3 (bottom)	High intensity

Table 26, Functionality, Automated/Automatic Transmission Shift Control

* For functions with cruise control active, see [8.01.01 General Description, Standard Adaptive Cruise Control](#).

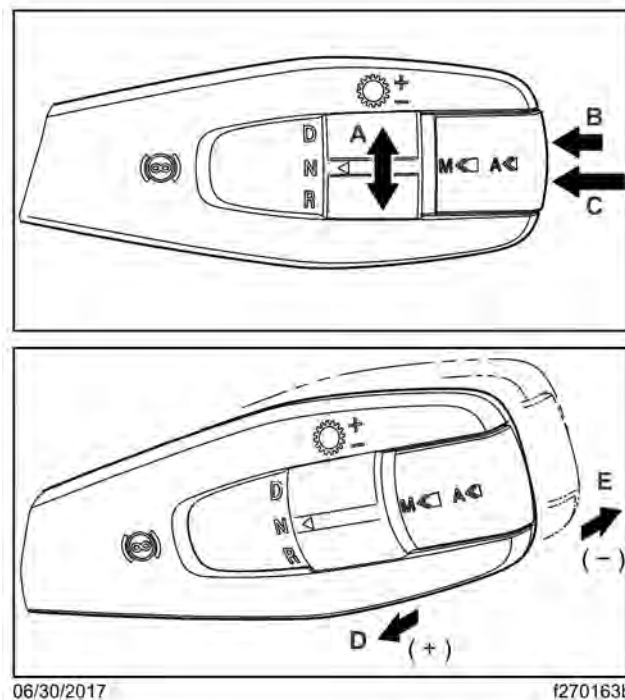

See Table for a description of control functionality.

- A. Rotate for drive (D), neutral (N), or reverse (R).
- B. Short press for automatic mode or switch between available modes.
- C. Long press for manual mode.
- D. Pull for upshift (+) request.
- E. Push for downshift (-) request.

Fig 296, Automated/Automatic Transmission Shift Control

See Table for a description of control functionality.

15.01.04 Engine Brake

The engine brake is controlled by the lever position, as shown in Fig.247, [Engine Brake Positions](#). At the top position, the engine brake is off, and at the three lower positions, the engine brake is on and the intensity (low, medium, high) increases with each step down.

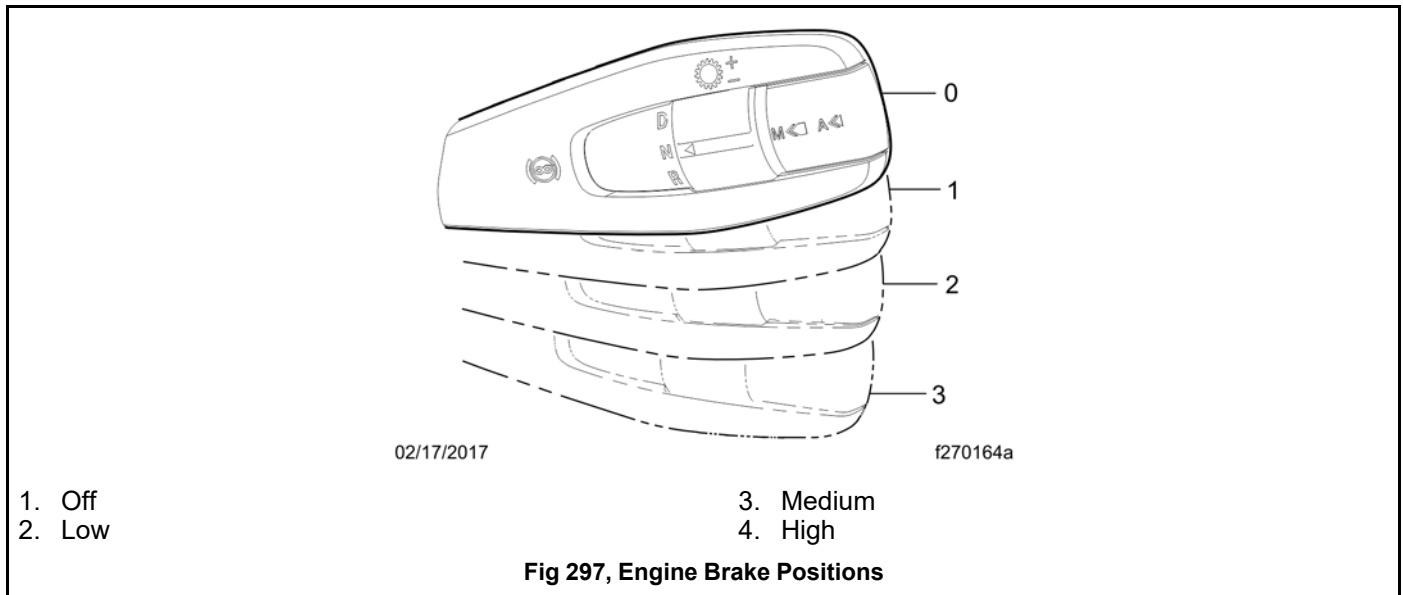

NOTE: Using the engine brake with cruise control can be used to activate Descent Control Mode or Deceleration Mode. For more information, see "Cruise Control", see [8.01.01 General Description, Standard Adaptive Cruise Control](#).

15.01.05 Power Up and Shift into Gear

1. With the parking brake set and Neutral (N) selected on the shift control, turn the ignition switch to the ON position.
2. Start the engine.
3. Apply the service brake.
4. Select the desired starting gear.
5. Release the parking brake.
6. Release the service brake and apply the accelerator.

15.01.06 Gear Display

The current transmission gear and driving mode are displayed in the static menu at the bottom of the driver display screen. See Fig.248, [Typical Gear Display \(Detroit and Eaton\)](#).

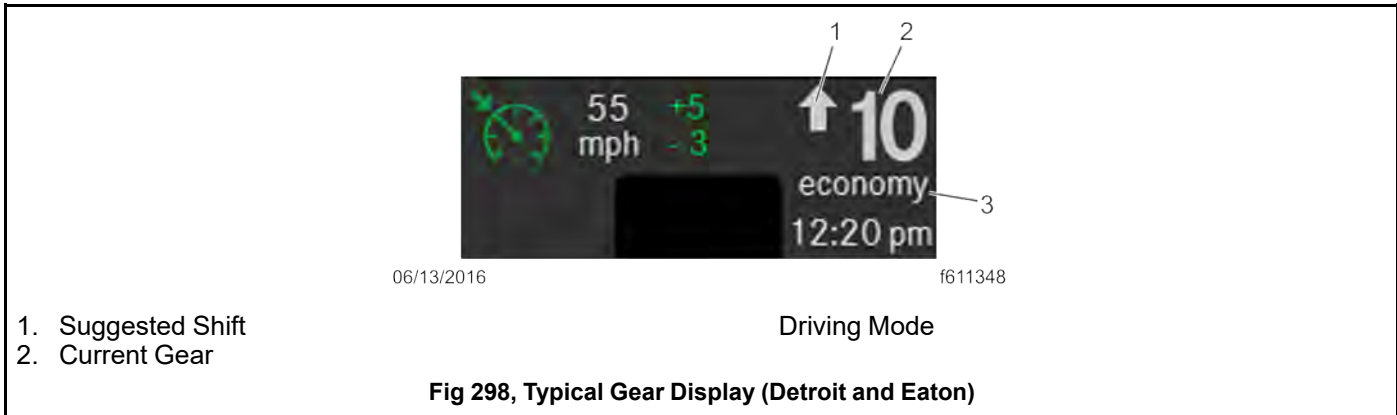

15.01.07 Selected Gear (Detroit and Eaton Transmissions)

If the selected gear is different than the current gear for longer than a half second, the current gear display will flash and the selected gear value will be shown. Once the current gear and selected gear match, the selected gear display disappears and the current gear display stops flashing.

15.01.08 Suggested Shift (Detroit and Eaton Transmissions)

In Manual mode only (if available), a suggested shift is displayed to indicate the most economical gear available. The suggested shift is the number of up or down arrows from the current gear with a maximum of three up or down arrows.

15.02 Detroit™ Automated Transmissions (DT12)

15.02.01 General Information

Detroit transmissions have twelve forward gears and up to four reverse gears that can be shifted automatically or manually. Shifting and clutch actuation are computer controlled, and there is no clutch pedal needed to operate the vehicle. Automatic shifts are selected for fuel economy or engine power. Manual shifts can be requested with the shift control and the transmission ECU grants them when conditions permit. In all cases, shifts depend on the following factors: engine speed, accelerator pedal position, service brake usage, engine brake operation, vehicle load status, and road conditions.

NOTE: To avoid potential engine stall risk or unexpected shifting, use the interaxle differential lock when the vehicle is operated in slippery conditions. See [17.01.01 Drive Axles With Differential Lock](#) for information about the interaxle differential lock.

15.02.02 Driving Modes

There are three driving modes: Manual, Automatic Economy, and Automatic Performance. To activate the manual drive mode, press and hold the mode switch briefly. Press the switch quickly to activate the automatic drive mode or change between modes. See [Fig.249, Automated/Automatic Transmission Shift Control](#).

In Automatic Economy mode, gear shifts are designed for saving fuel. In Automatic Performance mode, gear shifts are designed for higher performance and are made at higher engine speeds. In manual mode, gear shifts are requested manually.

NOTE: In Automatic Performance mode, the transmission will automatically change to Automatic Economy mode if it hasn't received a request for more power in several minutes, unless current road conditions require higher engine performance.

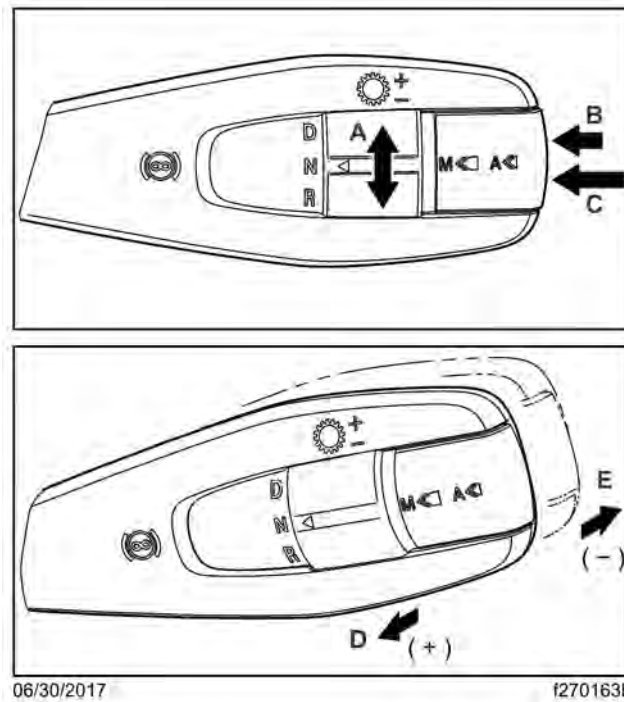

See Table for a description of control functionality.

- | | |
|--|------------------------------------|
| A. Rotate for drive (D), neutral (N), or reverse (R). | C. Long press for manual mode. |
| B. Short press for automatic mode or switch between available modes. | D. Pull for upshift (+) request. |
| | E. Push for downshift (-) request. |

Fig 299, Automated/Automatic Transmission Shift Control

See Table for a description of control functionality.

15.02.03 eCoast

The eCoast feature can improve driving economy. When conditions permit, the transmission control automatically shifts the transmission to neutral to coast at speeds of approximately 50 mph (80 km/h) and above. However, the vehicle can coast down to 45 mph (72 km/h). An "E" shows in the gear display when eCoast is in effect. See Fig. 250, [eCoast Display](#).

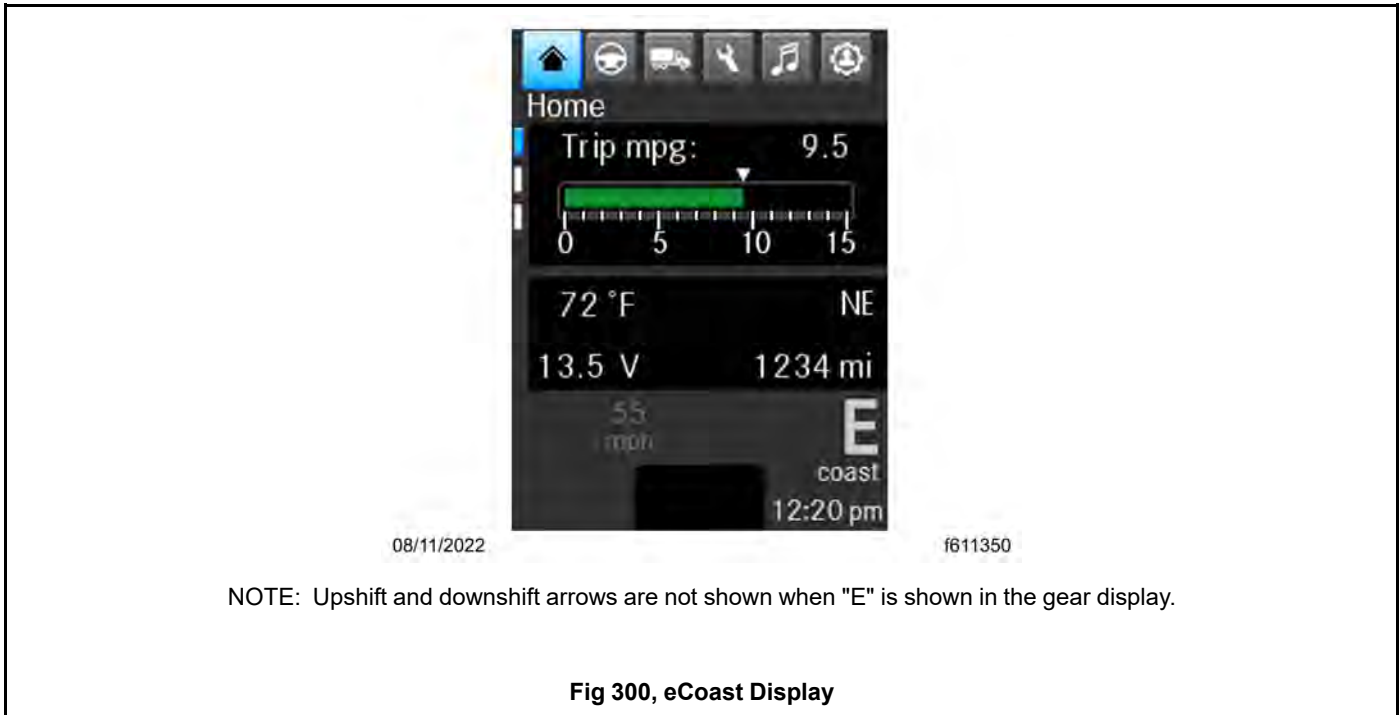

To turn eCoast on or off, navigate to the transmission settings screen. See Fig. 251, [eCoast and Creep Mode On/Off Screen](#).

The eCoast function is not active when any of the following occur:

- the accelerator pedal is pressed.
- vehicle acceleration rate is exceeded.
- the service brake pedal is pressed.
- the engine brake is in use.
- cruise control brakes or accelerates.
- vehicle speed exceeds the cruise control set speed by more than approximately 4 mph (6 km/h).
- the speed limiter is active and the maximum speed set is exceeded.
- diesel particulate filter (DPF) regeneration occurs.

NOTE: eCoast availability and the On/Off screen are customer-selectable parameters. To enable or disable eCoast, see an authorized Freightliner service facility.

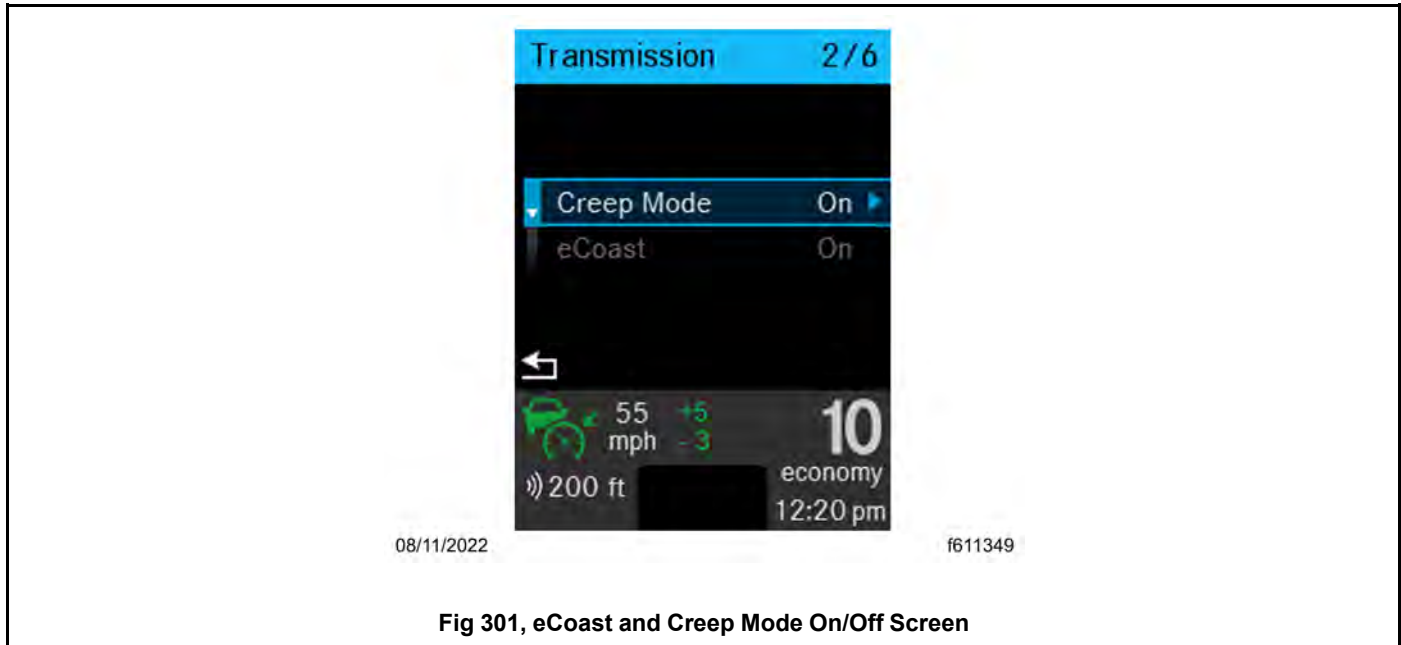

Fig 301, eCoast and Creep Mode On/Off Screen

15.02.04 Creep Mode

Creep mode allows the vehicle to be maneuvered at very slow speeds. To activate Creep mode for the first time within the current driving cycle, press the accelerator pedal to launch the vehicle, thereby modulating the clutch and allowing it to slip. Following this and for the duration of the current driving cycle, Creep mode is active.

Once the vehicle is stopped via the service brakes, the vehicle will begin to creep again, without the accelerator pedal actuation, as soon as the service brakes are released.

To begin using Creep mode (once active) from a parked position, shift from neutral to either drive or reverse, release the service brakes, and briefly depress the accelerator pedal. The vehicle's urge to move can then be felt.

If creep is active and no acceleration is achieved, then Creep mode will abort. A display message notifies the operator when Creep mode is about to be aborted.

IMPORTANT: When slowing down from higher speeds in drive or reverse, remember that Creep mode will be in effect at lower speeds. Use the service brakes to stop the vehicle.

To turn Creep Mode on or off, navigate to the transmission settings screen (if available). See Fig. 252, [eCoast and Creep Mode On/Off Screen](#).

NOTE: Creep mode availability and the On/Off screen are customer-selectable parameters. To enable or disable creep mode, see an authorized Freightliner service facility.

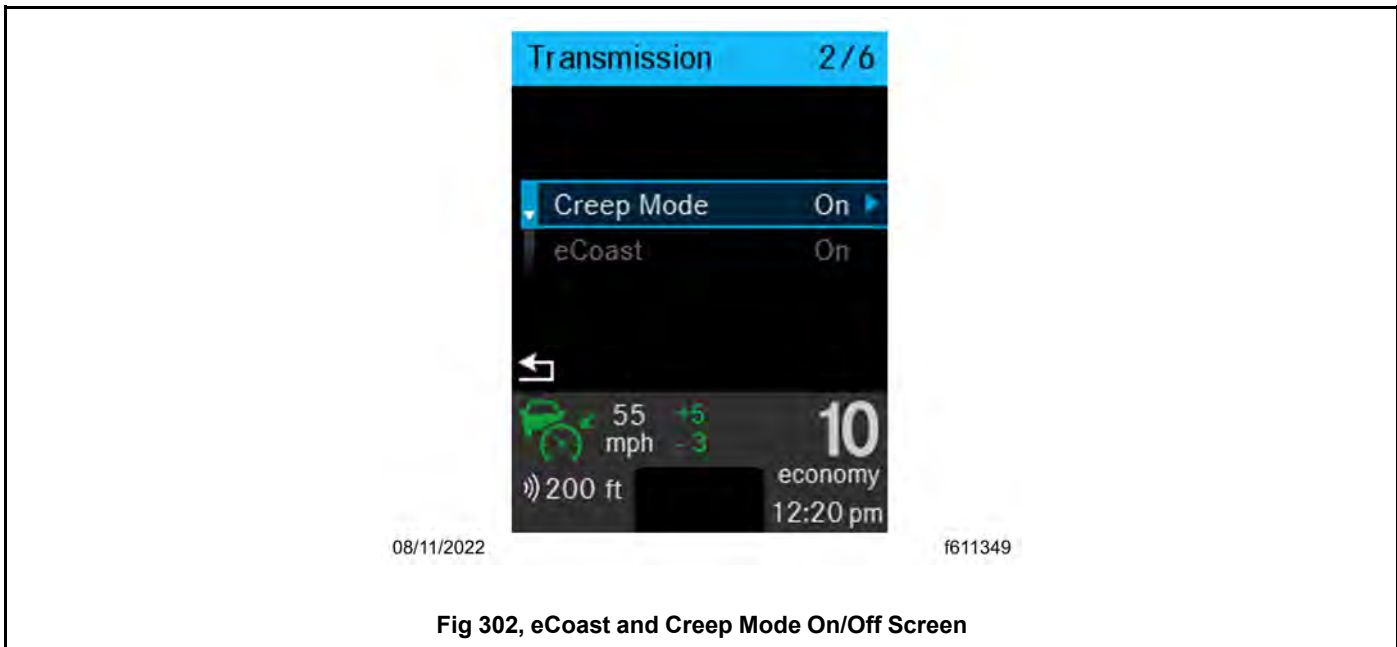

Fig 302, eCoast and Creep Mode On/Off Screen

15.02.05 Hill Start Aid (HSA)

Detroit transmissions are equipped with a Hill Start Aid (HSA) feature to prevent rolling backward when launching the vehicle on an uphill grade. The system delays the release of service brakes until enough torque is available to begin moving the vehicle forward. The system will hold the brakes for a maximum of 3 seconds. If driveline torque is not detected, the system will audibly alert the driver and release the brakes.

15.02.06 Clutch Abuse Protection

A vehicle equipped with a Detroit transmission does not have a clutch pedal, but still has a clutch that is operated automatically and can be damaged by abusive driver actions. To protect the clutch, the vehicle has a clutch abuse protection system that alerts the driver and restricts functionality when needed. Extended periods in Creep Mode, slipping the clutch (using the accelerator pedal to hold the vehicle on a hill, for example), and high clutch temperatures can activate the clutch abuse protection system. A display message notifies the operator when the protections are needed.



NOTICE:

To hold the vehicle stationary on an uphill slope, use the service brakes, not the accelerator pedal. Using the accelerator pedal can overheat and damage the clutch. To start moving, use the accelerator pedal and release the brakes as the vehicle begins to move.

There are three clutch abuse protection levels. At each, the driver is alerted and functionality is modified; see Table.33, [Clutch Abuse Alerts and Protections](#).

To avoid clutch overheating, follow these tips:

- To hold the vehicle stationary on an uphill slope, use the service brakes, not the accelerator pedal.
- To start moving on an uphill slope, use the accelerator pedal and release the brakes as the vehicle begins to move.
- When hooking up to a trailer, ensure the trailer is high enough to back under, and use first gear reverse.
- Avoid starting in higher gears, and start in first gear when a trailer is attached.
- Ensure trailer brakes have had time to completely release prior to starting.
- Do not use Creep mode for an extended period. Stop or adjust the vehicle speed when warned to deactivate Creep mode.

Clutch Abuse Alerts and Protections				
Alert Level	Alert	Protections		
		Highest Start Gear	Creep Mode	Clutch Function
1	Heavy clutch load message	1	No restriction	Normal function
2	Heavy clutch load message	1	Disabled	Normal function
3	Clutch overload message and buzzer	1	Disabled	If the accelerator pedal is depressed, the clutch closes at fixed rate. If the accelerator pedal is released, the clutch opens at fixed rate.

Table 27, Clutch Abuse Alerts and Protections

15.02.07 Engine Overspeed Alerts

To help protect the engine, the system has display messages to notify the operator when the engine has exceeded certain thresholds and needs to be slowed down before significant engine damage occurs. There are two warnings, one at about 2300 rpm and another at 2500 rpm, indicated with messages and a fault code.

15.02.08 Descent Control Mode

Descent Control mode helps control the vehicle and engine speed when descending a grade.

NOTE: Before engaging Descent Control mode, determine an appropriate speed for the vehicle load and grade of the road.

To activate Descent Control mode, manually set the engine brakes with the shifter stalk and, while the engine brakes are actively working, set cruise to the desired descent speed. A Descent Control mode engaged icon will appear on the ICUC screen showing it is active. See Fig.253, [Descent Control Mode Active](#).



The Descent Control mode will attempt to manage the vehicle's speed by varying the engine brake level. The driver should be ready to intervene by applying the service brakes if the grade is too steep and the vehicle is traveling too fast. Applying the service brake to slow the vehicle will not cancel cruise control. Once the service brake is released, the vehicle speed becomes the new Descent Control set speed. A pop-up will appear on the instrument cluster screen to notify the driver of the new speed. See Fig.254,[New Descent Control Mode Set Speed Pop-Up](#).



When the vehicle's descent is complete, return the engine brake stalk to the OFF/Auto position. At this point the Descent Control set speed will become the new cruise speed.

15.02.09 Hill Descent Upshift Feature

NOTE: It is critical that the driver maintains complete control over the vehicle at all times. The proper speed, and gear if in manual mode, should be selected before the crest of any hill to ensure a safe descent. The driver should apply engine and service brakes appropriately during any descent.

If the feature is enabled, the Detroit™ automated transmission (DT12) is capable of upshifting automatically when descending grades. When the vehicle is descending without engine or service brake application, the DT12 will upshift at 2000 rpm. If the engine or service brake is applied during descent, the DT12 will upshift at 2400 rpm.

15.02.10 Transmission Low Air Warning



CAUTION:

If the yellow "Caution: Transmission Air Supply Low" popup appears while the vehicle is in operation, slow down, safely pull the vehicle off the road, then correct the problem.

Pneumatic controls are used to shift the transmission. If there is inadequate air pressure, a yellow caution pop-up will appear and the quality of gear shifts may be degraded. See Fig.255, [Low Transmission Air Pressure Pop-up](#). Wait for air pressure to build before operating the vehicle.

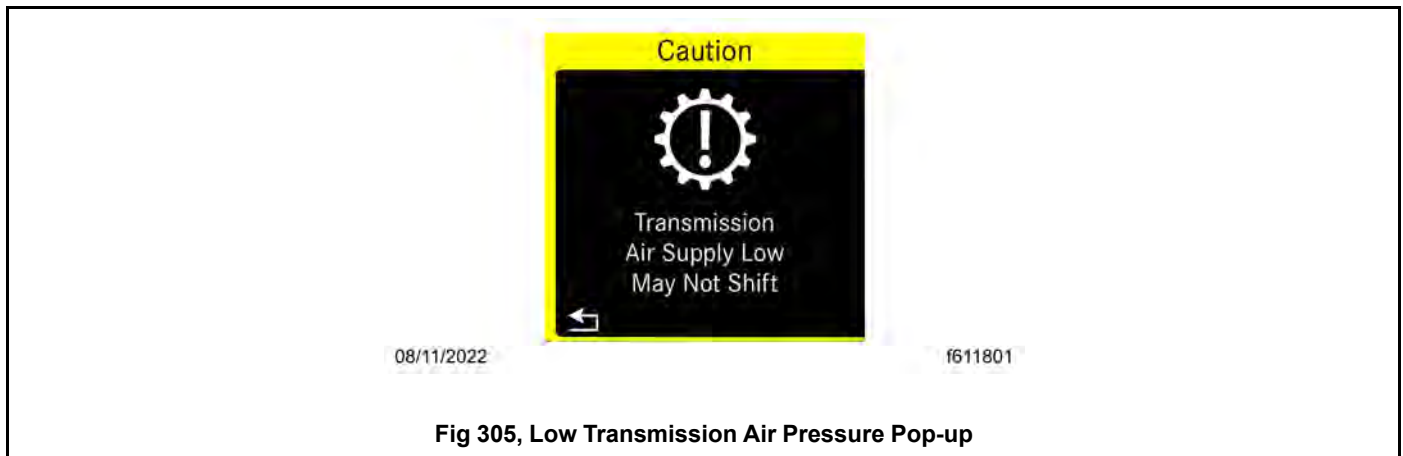

CAUTION:

If the red "Warning: Transmission Will Not Shift" popup appears while the vehicle is in operation, choose the safest location available to pull the vehicle off the road. Prepare for the vehicle to be immobile if the problem cannot be resolved.

If a severe loss of air pressure occurs, a red warning pop-up will appear and the transmission will not shift. See Fig. 256, [No Transmission Air Pressure Pop-up](#).



Fig 306, No Transmission Air Pressure Pop-up

15.02.11 Clutch Abuse Alerts and Protections

Clutch Abuse Alerts and Protections				
Alert Level	Alert	Protections		
		Highest Start Gear	Creep Mode	Clutch Function
1	Heavy clutch load message	1	No restriction	Normal function
2	Heavy clutch load message	1	Disabled	Normal function
3	Clutch overload message and buzzer	1	Disabled	If the accelerator pedal is depressed, the clutch closes at fixed rate. If the accelerator pedal is released, the clutch opens at fixed rate.

Table 28, Clutch Abuse Alerts and Protections

15.02.12 Auto Neutral



WARNING:

Do not leave the driver's seat without placing the shift stalk lever in the neutral position and applying the parking brake. Failure to do so could cause property damage and personal injury.

The auto neutral feature shifts the Detroit transmission into neutral if the drive direction switch is left in drive or reverse for an extended period of time. The driver is warned of a pending shift with a flashing N in the gear position display of the instrument cluster. A brief warning buzzer activates when the transmission shifts into neutral. See Table.35, [Direction Switch D or R](#). for all the conditions and indicators that are possible.

NOTE: If the auto neutral feature is activated, apply the service brake and cycle the gear direction switch to neutral, and back to the desired position.

Additionally for vehicles equipped with CPC3Evo, if the engine is shutdown without the drive direction switch in the N position, the warning buzzer activates for a long period of time, and a pop-up appears on the driver display screen, prompting the driver to place the shifter into the neutral position.

**WARNING:**

If the transmission doesn't achieve neutral before shutdown, it will not restart until it can complete the shift to neutral.

If neutral gear is not achieved, a pop-up message appears on the driver display screen, encouraging the driver to start the engine and allow the transmission to achieve neutral gear.

Direction Switch D or R				
CPC model	All		CPC4	CPC3Evo
Key Position	ON with Engine Idling		Ignition OFF	Ignition OFF
Brake Position	Parking brake ON	Parking brake OFF	Parking brake ON or OFF	Parking brake ON or OFF
Gear Display	Flashing N (short duration)	Flashing N (long duration)	—	Shift into neutral
Warning Buzzer	Short duration activation	Short duration activation	—	Long duration activation
Gear Position	Neutral, when the buzzer sounds	Neutral, when the buzzer sounds	In gear or neutral	In gear or neutral

Table 29, Direction Switch D or R

15.03 Eaton™ Automated Transmissions

15.03.01 Multi-Function Stalk Switch

Eaton automated transmissions use a multi-function stalk switch, shown in Fig.

257, [Automated/Automatic Transmission Shift Control](#), or a push-button shift selector to select mode, direction, neutral, low, and to make manual shifts. To know what gear the transmission is in, see the driver display. Forward shifts can be made either manually or automatically.

Automatic Mode (A)

In automatic drive mode, upshifts and downshifts are made by the transmission without driver intervention.

Use the mode switch on the shift control to select the automatic mode (A). Rotate the D/N/R switch to Drive (D), and press down on the throttle pedal. The transmission will shift automatically.

NOTE: If attempting to select a non-Neutral mode without applying the service brakes, the transmission will not shift into gear. To shift into gear, select Neutral, apply the service brakes, and select the desired mode again.

In Drive, the start gear is automatically selected. The selected start gear can vary depending on several vehicle inputs such as load, grade, and axle/transmission ratio. The start gear can be changed using the shift control, provided the selected gear would allow the vehicle to launch without damaging the transmission. If the start gear is changed using the shift control, it will be the default until the vehicle is powered down or the selection is changed again manually.

IMPORTANT: Prior to ascending a steep grade, either reduce the default start gear by one (using the shift control) or apply full throttle for the duration of the grade so the vehicle maintains the proper engine and vehicle speed during the entire grade.

In Drive, the transmission automatically performs upshifts and downshifts. However, when the transmission is near the shift point, the shift can be forced using the upshift or downshift function of the shift control.

NOTE: The transmission may deny a shift while ascending or descending a grade if the load of the vehicle and grade of the terrain in combination with the drivetrain ratio and engine torque fall outside of the acceptable range to perform a shift. If the shift is denied, a tone will sound.

Manual Mode (M)

In manual mode, the driver requests upshifts and downshifts instead of letting the Eaton transmission select them automatically. Manual shifting may be helpful when traversing a work site, railroad tracks, or steep grades, for example.

Use the mode switch on the shift control to select the manual mode (M). To drive forward, rotate the D/N/R switch to Drive (D), and press down on the throttle pedal. To shift up, pull the lever up (towards you); to shift down, push the lever down (away from you). The system holds the current gear unless a shift is requested or if the system initiates a manual mode override.

NOTE: The transmission may deny a shift while ascending or descending a grade if the load of the vehicle and grade of the terrain in combination with the drivetrain ratio and engine torque fall outside of the acceptable range to perform a shift. If the shift is denied, a tone will sound.

NOTE: If attempting to select a non-Neutral mode without applying the service brakes, the transmission will not shift into gear. To shift into gear, select Neutral, apply the service brakes, and select the desired mode again.

Manual Mode Override

The system is equipped with a manual mode override function. If the vehicle is being "back driven" (for example, descending a grade and the engine speed is excessively high), the system will upshift automatically. Also, if the start gear is changed and it causes the engine to lug at takeoff, the system will override the current position and select the best available gear.

Low (L)

Use Low when wanting to maximize engine braking and minimize the use of the brake pedal—for example, when driving down long grades or when coming to a stop. To select Low, push down on the multi-function stalk switch, and hold in the down-shift position for half a second or more. The lowest available start gear will be selected (the starting gear cannot be changed in Low).

If Low is selected while moving, the transmission will not upshift (unless the system initiates a Low override). The system will downshift at the earliest opportunity to provide maximum engine braking.

NOTE: If attempting to select a non-Neutral mode without applying the service brakes, the transmission will not shift into gear. To shift into gear, select Neutral, apply the service brakes, and select the desired mode again.

Low Override

The system is equipped with a Low override function. If the vehicle is being "back driven" (for example, descending a grade and the engine speed is excessively high), the system will upshift automatically. Also, if the start gear is changed and it causes the engine to lug at takeoff, the system will override the current position and downshift.

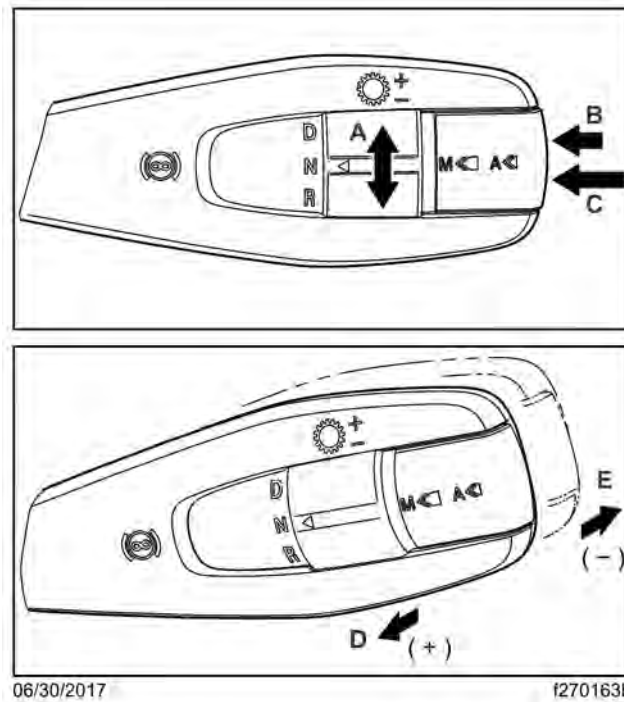

See Table for a description of control functionality.

- | | |
|--|------------------------------------|
| A. Rotate for drive (D), neutral (N), or reverse (R). | C. Long press for manual mode. |
| B. Short press for automatic mode or switch between available modes. | D. Pull for upshift (+) request. |
| | E. Push for downshift (-) request. |

Fig 307, Automated/Automatic Transmission Shift Control

See Table for a description of control functionality.

15.03.02 Push-Button Shift Selector

Gear information is presented to the driver on the push-button shift selector, shown in Fig. 258, [Eaton Push-Button Shift Selector](#), usually mounted on the right-hand control panel. On this display, the information is presented as follows:

- To select neutral, press the N button. When neutral is engaged, the telltale LED will light up next to the N button.
- To select reverse, press the R button. When reverse is engaged, the telltale LED will light up next to the R button.
- To select drive, press the D button. When drive is engaged, the telltale LED will light up next to the D button.
- To select low gear, press the LOW button. When low is engaged, the telltale LED will light up next to the LOW button.
- To change gears manually, press the MANUAL button. When the manual mode is engaged, the telltale LED will light up next to the MANUAL button.
- Use the shift buttons (upshift/downshift) to change the current starting gear selection in R, D, and LOW. In MANUAL, the shift buttons can be used to select gears.
- In automatic mode, the number of the forward gear currently engaged appears continually on the mode indicator when in drive. In MANUAL, the last gear selected appears on the mode indicator.
- If the SERVICE indicator illuminates, take the vehicle as soon as possible to an authorized Freightliner service facility.
- The mode button is reserved for future use.

IMPORTANT: To prevent engine overspeed, the transmission software will override both MANUAL and LOW if necessary. The system will not respond to gear selection requests that will either overspeed or excessively lug the engine.

Automatic Mode

When the transmission is in automatic mode, the transmission automatically selects and engages the gears, although the transmission will respond to upshift and downshift requests as though in manual mode. See the instructions for shifting under heading 'Manual Mode' below.

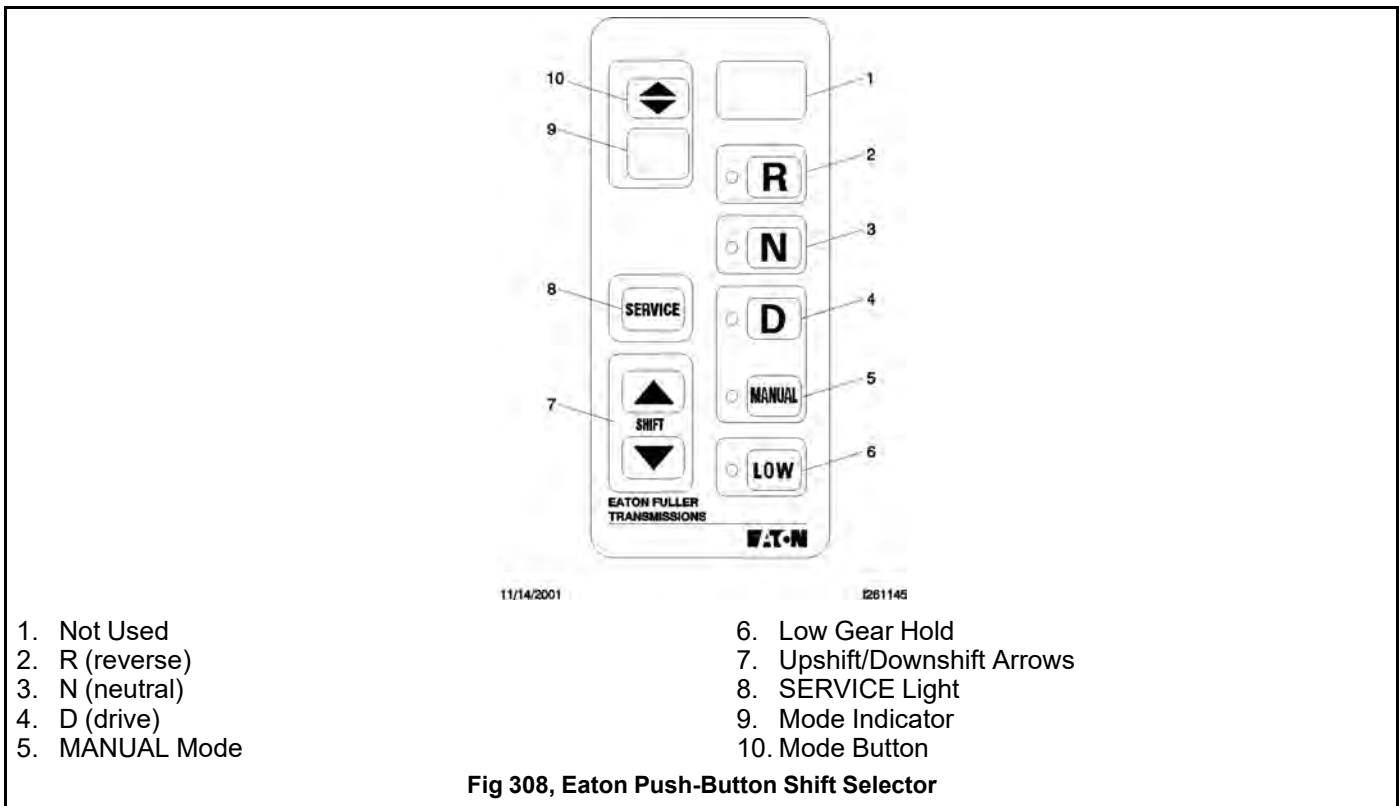

Manual Mode

To select MANUAL mode, press the MANUAL button on the push-button shift selector. When the transmission is in manual mode, the driver must select the appropriate gear, using the shift buttons on the push-button shift selector.

To upshift in MANUAL, press the upshift button (up arrow), and release. The number of the gear will appear on the mode indicator. If the requested gear is available, the transmission will shift up.



NOTICE:

Do not attempt to upshift until the vehicle has reached a sufficient speed. The clutch absorbs the speed difference by generating heat, which causes the clutch to wear out too soon.

Many drivers upshift into the next gear or even skip-shift into a higher gear before the vehicle has reached the correct speed. This type of shifting is almost as bad as starting off in a gear that is too high. When the engine speed (rpm) and the vehicle speed (mph or km/h) are too far apart, the clutch must absorb the difference in speed by generating heat.

To downshift in MANUAL, press the downshift button (down arrow), and release. The number of the gear will appear on the mode indicator. If the requested gear is available, the transmission will shift down.

If any requested gear is not available, an audible warning will sound and the digital display will indicate that the gear is not available.

Selecting Gears

R (Reverse)

Reverse (R) is used to back the vehicle. Make sure the vehicle comes to a full stop and the clutch pedal has been pressed before shifting into reverse.

To select reverse, press the clutch pedal to the floor. Then press the R button.

N (Neutral)

Neutral (N) is used for starting, parking, or any stationary operation. No gear is selected. The transmission must be in neutral to start the engine.

IMPORTANT: If the vehicle starts up in any gear but neutral, bring the vehicle to an authorized Freightliner service facility as soon as possible.

To select neutral, press the clutch pedal to the floor. Then press the N button. Set the parking brakes and slowly release the clutch pedal.

NOTE: Neutral is always available during vehicle operation. When in neutral, requests to upshift or to downshift are ignored.

D (Drive)

Drive (D) is used for normal highway driving. In drive, the transmission shifts into the proper gear for starting, and then automatically selects additional gears as needed, in a range between the starting gear and the highest gear.

To select drive, press the clutch pedal to the floor. Then press the D button. Slowly release the clutch pedal and drive the vehicle.

To start up in a gear other than the normal starting gear, push the upshift arrow with D selected, and while the vehicle is stopped.

IMPORTANT: AutoShift will not start up in any gear higher than third gear.

The number of the gear selected will flash on the auxiliary display until the driver presses the clutch pedal. This gear will be stored in memory as the default starting gear until a different starting gear is selected by the driver, or until the engine is shut down.

NOTE: The transmission may be programmed so that it is not possible to select a starting gear other than the preprogrammed starting gear.

L (Low)

LOW is used to hold the transmission in low gear when descending steep hills. If LOW is selected when the vehicle is stopped, the transmission remains in low gear until drive is selected. If LOW is selected while the vehicle is moving, the transmission downshifts at a higher engine speed than normal, in order to maximize the engine braking effect.

To select LOW, press the clutch pedal to the floor. Then press the LOW button. Slowly release the clutch pedal and drive the vehicle.

IMPORTANT: Before parking the vehicle, always do the following:

- Place the transmission in neutral.
- Set the parking brakes.
- Chock the tires, if parking on an incline.

15.03.03 Clutch Abuse Protection

Although a vehicle equipped with an Eaton automated transmission uses an automated clutch, the clutch can still overheat and slip with improper use. The clutch abuse protection feature helps protect the clutch if the automated clutch

starts to overheat. When the clutch abuse protection feature initiates and sounds a warning tone, full clutch actuation must be completed quickly. If it is not completed quickly enough, the system will either open the clutch (if the throttle pedal is not being pressed) or close the clutch (if the throttle pedal is being pressed). If the abuse continues, the system will open the clutch and take away throttle control briefly to allow the clutch to cool down.

To protect the clutch:

- Select the lowest possible start gear for the application.
- Use Creep Mode when appropriate.
- Use the service brakes and the Hill Start Aid when launching on a grade.
- Minimize the time it takes to engage the clutch from rest.
- Do not use the throttle to hold the vehicle on a grade; use the service brakes.
- Do not use the throttle to stop roll back on an incline after Hill Start Aid disengages; use the service brakes, and then relaunch.
- Do not continually start and stop, especially when loaded; use a lower gear or Creep Mode.

15.03.04 Creep Mode

The Creep Mode function allows the vehicle to maintain a constant speed at engine idle without the driver holding the throttle pedal position. This mode is useful for very low-speed maneuvering and applications where steady vehicle speed is required. The vehicle speed is determined by the selected gear ratio operating at governed low engine idle speed. Any available gear may be selected, though the transmission will downshift or exit Creep Mode to prevent stalling if the engine lugs due to load conditions.

By default, Creep Mode can be activated while in Manual Mode or Low. Eaton's ServiceRanger diagnostic software can be used to enable Creep Mode in Automatic Mode and/or Reverse.

15.03.05 Engaging Creep Mode

To engage Creep Mode:

1. Select Low, Manual, or Automatic Mode, and the desired gear (while stopped or moving).
2. Apply the throttle pedal to accelerate the vehicle until the clutch is closed (engaged).
3. Release the throttle pedal. The vehicle will continue moving at governed low engine idle speed.

15.03.06 Exiting Creep Mode

To exit Creep Mode, apply the throttle pedal to accelerate temporarily, or select a higher gear in Manual Mode. (Creep Mode can be resumed in the selected gear by releasing the throttle pedal.)

NOTE: The transmission will exit Creep Mode if the engine lugs 150 rpm below the governed low engine idle speed. In this case, a lower gear should be selected if available.

15.03.07 Hill Start Aid

Eaton transmissions are equipped with a Hill Start Aid (HSA) feature to prevent the vehicle from rolling while on grades steeper than 3 percent and allow for a controlled launch. A grade sensor is used to determine when to engage the feature.

HSA is 'on' by default. It can be turned off by pressing and releasing the override switch on the dash (see [5.01 Ignition Switch and Key](#)). HSA will turn back on after the first successful launch.

When the vehicle is stopped on a grade greater than 3 percent and in a forward mode or reverse, depress the service brakes then release them. The vehicle will begin to move after 3 seconds, and the clutch will perform partial engagements to slow the vehicle motion. Either step on the brake or apply the throttle to continue negotiating the grade.

15.03.08 Engine Overspeed Protection

The system will upshift if necessary to prevent engine overspeed in Drive, Manual, and Low.

15.03.09 Shuttle Shifting

Shuttle shifting from reverse to any forward mode is only allowed if the vehicle speed is approximately zero.

15.03.10 Auto Start Gear Selection and Override

The transmission uses various inputs to automatically select the best start gear in Drive and Manual. This selection can be changed using the shift control; however, if the selection requested could cause damage or engine lugging, the request will be denied and a tone will sound.

15.03.11 Skip Shifting

When appropriate, the transmission may skip shift in Drive. When prevailing conditions like load and grade allow, skip shifts can be performed in Manual mode using the SmartShift control.

15.03.12 Auto Neutral

An Eaton automated transmission system will automatically shift to neutral if the vehicle is left in Drive and the parking brake is set. 'AN' will show on the gear display. To re-engage the transmission, select Neutral and then either Drive or Reverse on the shift control (it will re-engage regardless of whether the parking brake is released).

15.03.13 Automatic Traction Control

An Eaton automated transmission system requires the Automatic Traction Control (ATC) option to be enabled when driving in soft soil/sand to prevent wheel slippage and shifting issues.

With the ATC enabled, the system will engage the brakes on the wheel or side that the wheel slip is occurring to help the vehicle gain traction. The point at which the traction control will actuate the braking system increases with throttle: low throttle allows the system to brake the wheels earlier; heavy/full throttle raises the point of the acceptable wheel slip.

Adhere to the following points when driving with ATC enabled:

- If using Automatic mode in soft soil and/or sand, maintain the engine speed between 1000 and 1300 rpm to prevent unnecessary upshifting.
- If using Manual mode in soft soil and/or sand, do not attempt an upshift and try to maintain the current gear.
- If the vehicle comes to a stop in the sand it may be necessary to back up prior to attempting forward movement.

To disable the ATC, depress the ATC switch, see [5.01 Ignition Switch and Key](#). This mode allows for the drive axle wheels to spin.

15.03.14 Load-Based Shifting

An Eaton automated transmission system is adaptive and will change the shift points based on grade, engine RPM, throttle position, and vehicle load. After changing loads or powering up, the system needs to relearn these inputs for the first few shifts to make the proper adjustments.

15.03.15 Coasting

When coasting to a stop on level terrain, the transmission system may not downshift into the lower gears. It will select a gear after the throttle is applied.

15.03.16 Transmission Low Air Warning

**CAUTION:**

If the yellow "Caution: Transmission Air Supply Low" popup appears while the vehicle is in operation, slow down, safely pull the vehicle off the road, then correct the problem.

Pneumatic controls are used to shift the transmission. If there is inadequate air pressure, a yellow caution pop-up will appear and the quality of gear shifts may be degraded. See Fig.259,[Low Transmission Air Pressure Pop-up](#). Wait for air pressure to build before operating the vehicle.



CAUTION:

If the red "Warning: Transmission Will Not Shift" popup appears while the vehicle is in operation, choose the safest location available to pull the vehicle off the road. Prepare for the vehicle to be immobile if the problem cannot be resolved.

If a severe loss of air pressure occurs, a red warning pop-up will appear and the transmission will not shift. See Fig. 260,[No Transmission Air Pressure Pop-up](#).

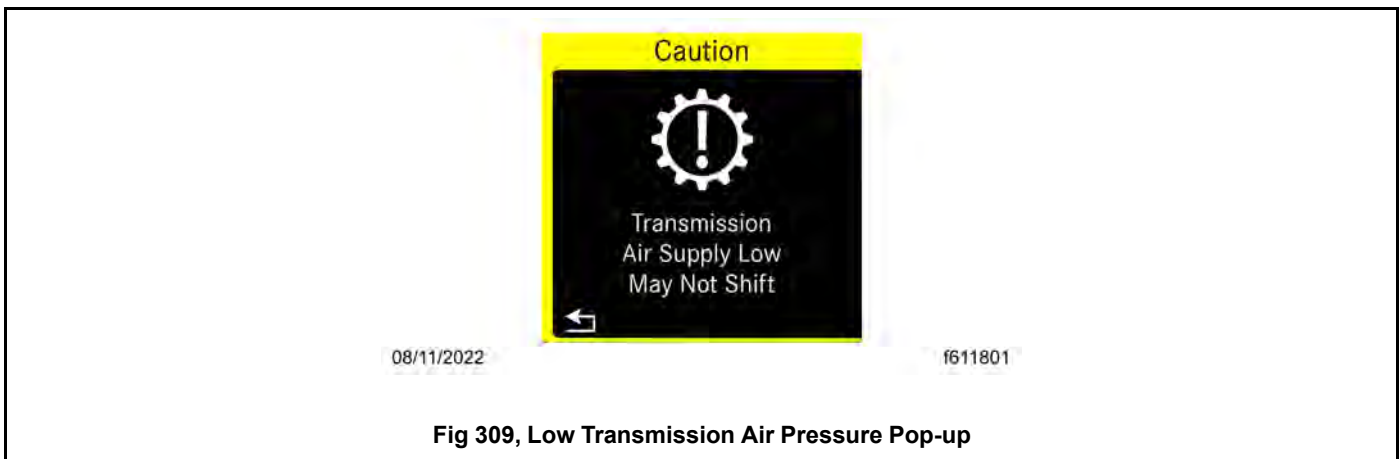

15.03.17 Transmission Prognostics

Some Eaton clutches require the application of grease for maintenance.

The Eaton transmission prognostics display can be found by navigating to the maintenance screens in the driver display. The screen will state if the Grease Interval is OK or if grease needs to be added. See Fig. 261, [Eaton Transmission Prognostics](#).



Fig 311, Eaton Transmission Prognostics

If the system status cannot be read, the message "SNA" displays.

15.04 Allison Automatic Transmissions

15.04.01 General Information, Allison Transmissions

Refer to the Allison website for additional information: www.allisontransmission.com.

Allison transmissions have electronic shift controls that can be programmed to allow the use of different numbers of geared speeds. For instance, the transmission can be programmed to operate as a 4-speed, 5-speed, or 6-speed unit in the "primary" shift mode. If needed, a "secondary" shift mode can be programmed to provide another shift configuration to optimize vehicle use under different operating conditions. To activate a secondary shift mode, or other special functions programmed into the electronic control unit (ECU), briefly depress the mode switch on the multi-function stalk switch control; see Fig.262, [Allison Gear Display in Automatic Mode](#), item 3.

These transmissions use the multi-function stalk switch to select mode, direction, neutral, low, and to preselect lower ranges. The current gear, highest available gear, and mode are shown in the driver display; see Fig. 263, [Automated/Automatic Transmission Shift Control](#). Forward shifts can be made either automatically or by using Manual mode.

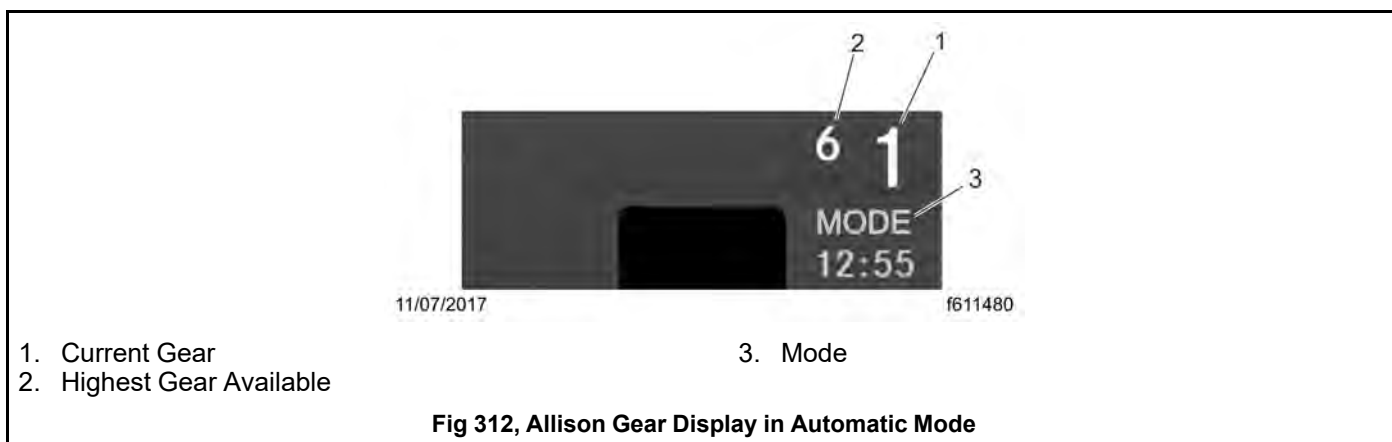

1. Current Gear
2. Highest Gear Available

3. Mode

Fig 312, Allison Gear Display in Automatic Mode

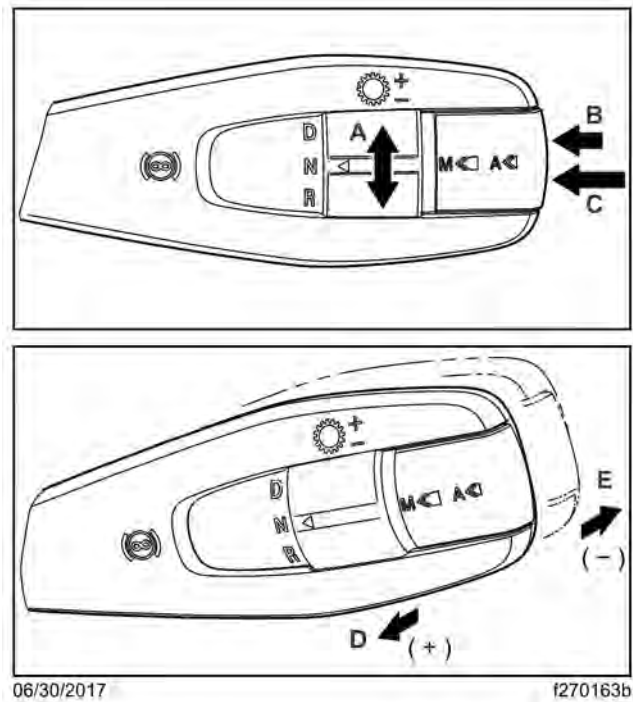

See Table for a description of control functionality.

- | | |
|--|---|
| <p>A. Rotate for drive (D), neutral (N), or reverse (R).</p> <p>B. Short press for automatic mode or switch between available modes.</p> | <p>C. Long press for manual mode.</p> <p>D. Pull for upshift (+) request.</p> <p>E. Push for downshift (-) request.</p> |
|--|---|

Fig 313, Automated/Automatic Transmission Shift Control

See Table for a description of control functionality.

15.04.02 Operation Tips, Allison Transmissions



WARNING:

Never shift from neutral (N) to drive (D) or reverse (R) at engine speeds above idle. The vehicle will lurch forward or backward, which could cause property damage and personal injury.



NOTICE:

The engine should never be operated for more than thirty seconds at full throttle with the transmission in gear and the output stalled. Prolonged operation of this type will overheat the transmission fluid and will result in severe damage to the transmission.

**NOTICE:**

Do not allow the vehicle to coast in neutral. This can result in severe transmission damage. Also, no engine braking is available.

The following tips highlight important operation principles.

- Use reverse (R) to back the vehicle. Completely stop the vehicle before shifting from a forward gear to reverse, or from reverse to forward.
- Select drive (D) for all normal driving conditions. The vehicle will start out in 1st gear (unless the transmission is programmed with 2nd gear start), and as speed increases, the transmission will upshift through each gear automatically. As the vehicle slows down, the transmission will downshift to the correct gear automatically.
- The pressure of your foot on the accelerator pedal influences the automatic shifting. When the pedal is fully depressed, the transmission will automatically upshift at higher engine speeds. A partially-depressed position of the pedal will cause the upshifts to occur at a lower engine speed.
- Occasionally the road, load, or traffic conditions make it desirable to restrict the automatic shifting to a lower range. The lower the gear range, the greater the engine braking power. When in Manual mode, push or pull on the multi-function stalk switch to reach the desired gear. In the lower gear ranges, the transmission will not upshift above the highest gear selected unless the hold override upshift speed is exceeded.
- Use neutral and apply the parking brake when the vehicle is parked with the engine running.

15.04.03 Automatic Mode (A)

In automatic drive mode, upshifts and downshifts are made by the transmission without driver intervention.

Automatic mode is the default start mode. If in manual mode, a short push on the shift control mode switch activates the automatic mode (A). Rotate the D/N/R switch to Drive (D), and press down on the throttle pedal. The transmission will shift automatically.

NOTE: If attempting to select a non-Neutral mode without applying the service brakes, the transmission will not shift into gear. To shift into gear, select Neutral, apply the service brakes, and select the desired mode again.

In Drive, the start gear is automatically selected. The transmission automatically performs upshifts and downshifts.

15.04.04 Manual Mode (M)

In manual mode, the driver selects the maximum allowed range. This may be helpful when traversing a work site, railroad tracks, or steep grades, for example.

When in automatic mode and with the D/N/R switch set to Drive (D), a long push on the shift control mode switch activates the manual mode (M). To increase selected range, pull the lever up (towards you); to decrease the selected range, push the lever down (away from you). The transmission will not upshift above the selected range unless the hold override upshift speed is exceeded.

See Fig.264, [Allison Gear Display in Manual Mode](#) for an example of the driver display with the transmission in manual mode.

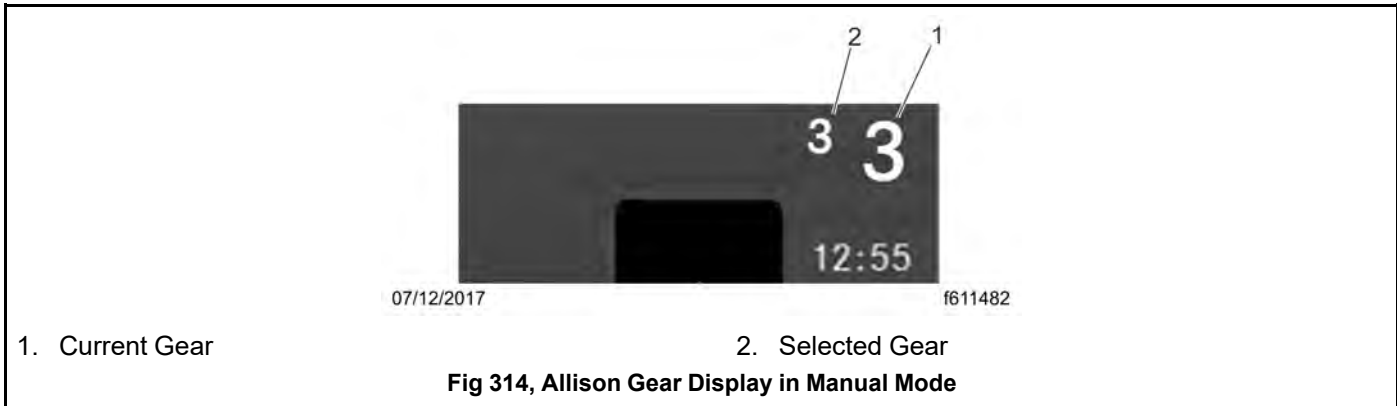

NOTE: The transmission may deny a downshift if the engine speed would fall outside of the acceptable range.

NOTE: If attempting to select a non-Neutral mode without applying the service brakes, the transmission will not shift into gear. To shift into gear, select Neutral, apply the service brakes, and select the desired mode again.

15.04.05 Low (L)

Use Low when wanting to maximize engine braking and minimize the use of the brake pedal—for example, when driving down long grades or when coming to a stop. To select Low, push down on the multi-function stalk switch, and hold in the down-shift position for half a second or more. The lowest available start gear will be selected (the starting gear cannot be changed in Low).

If Low is selected while moving, the transmission will not upshift (unless the system initiates a Low override). The system will downshift at the earliest opportunity to provide maximum engine braking.

In the driver display, the low gear is shown as "1." See Fig.265, [Allison Gear Display in Low Gear](#).

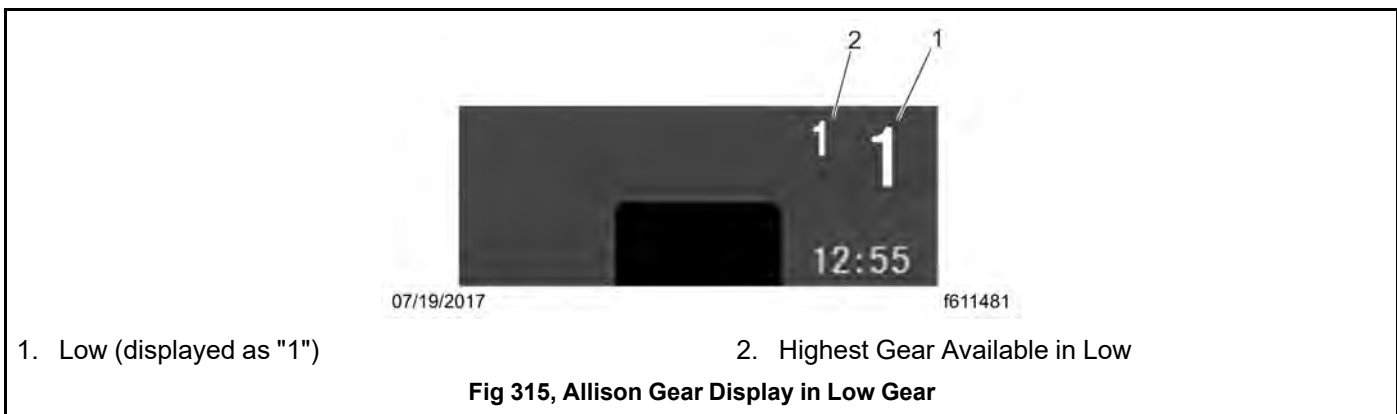

NOTE: If attempting to select a non-Neutral mode without applying the service brakes, the transmission will not shift into gear. To shift into gear, select Neutral, apply the service brakes, and select the desired mode again.

15.04.06 Transmission Prognostics

The Allison transmission prognostics display can be found by navigating to the maintenance screens in the driver display. The prognostics screen displays information on the transmission health status (oil filter status, oil level, and oil life). See Fig.266, [Allison Transmission Prognostics](#). If transmission health falls below acceptable limits, a message will be shown on the driver display.

NOTE: For a valid oil level measurement, the vehicle must be stopped on a level surface with the transmission in neutral (N).

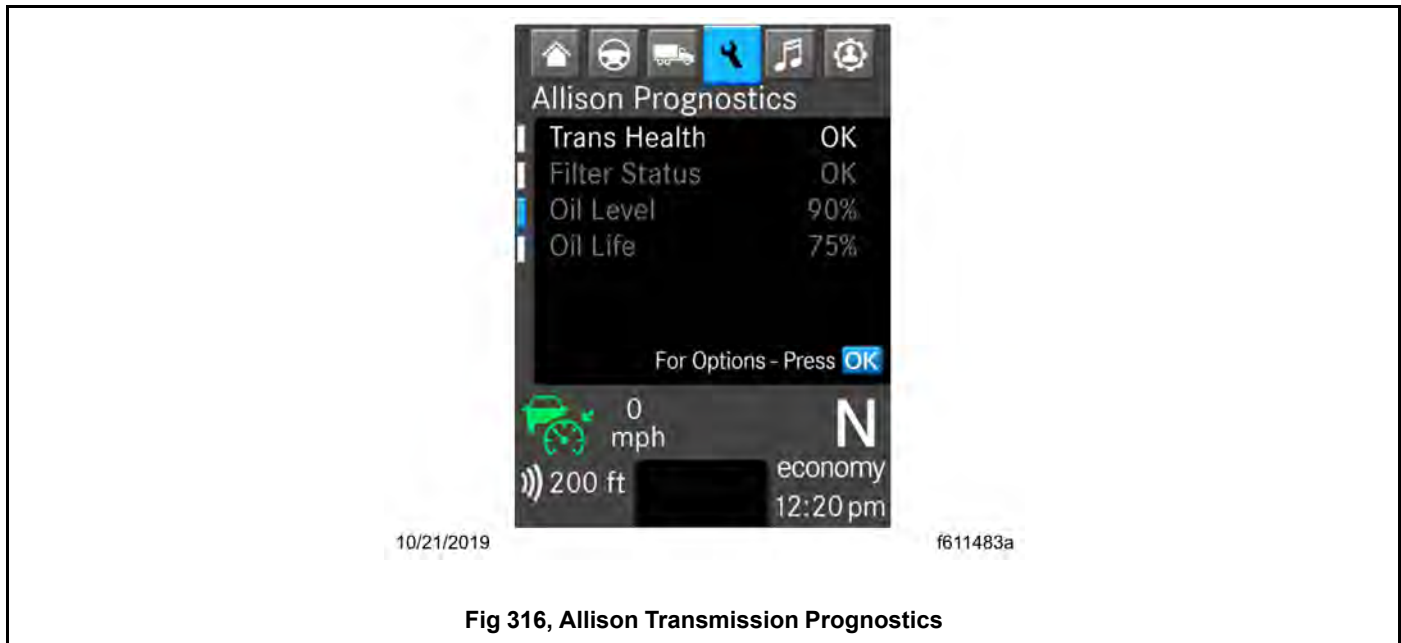

Fig 316, Allison Transmission Prognostics

15.05 Allison On-Highway Transmissions

15.05.01 Safety Precautions

The Allison on-highway transmissions are fully automatic and include the 1000 Series™, 2000 Series™, and 2400 Series™. Refer to the Allison website for additional information, www.allisontransmission.com.



WARNING:

Do not leave the vehicle unattended with the engine running. If you leave the vehicle and the engine is running, the vehicle can move suddenly, which could result in personal injury or property damage.

1000 Series

On vehicles with Allison 1000 series transmissions, do the following steps if you have to leave the cab with the engine running (for example, when checking the transmission fluid):

15.05.02 Without Park Position

1. Bring the vehicle to a complete stop using the service brake.
2. Ensure that the engine is at low idle rpm.
3. Put the transmission in neutral.
4. Apply the parking brake, and make sure it is properly engaged.
5. Chock the rear tires and take any other steps necessary to keep the vehicle from moving.

15.05.03 With Park Position

1. Bring the vehicle to a complete stop using the service brake.

2. Ensure that the engine is at low idle rpm.
3. Put the transmission in P (park).
4. Apply the parking brake (if equipped), and make sure it is properly engaged.
5. Engage the park range by slowly releasing the service brake.
6. Chock the rear tires and take any other steps necessary to keep the vehicle from moving.

15.05.04 2000 Series

On vehicles with Allison 2000 series transmissions, do the following steps if you have to leave the cab with the engine running (for example, when checking the transmission fluid):

15.05.05 Without Auto-Apply Parking Brake

Follow the instructions for vehicles with 1000 series transmissions, under the heading "Without Park Position."

15.05.06 With Auto-Apply Parking Brake

1. Bring the vehicle to a complete stop using the service brake.
2. Ensure that the engine is at low idle rpm.
3. Put the transmission in PB (auto-apply parking brake).
4. Apply the parking brake (if equipped), and make sure it is properly engaged.
5. Chock the rear tires and take any other steps necessary to keep the vehicle from moving.

15.05.07 2400 Series

On vehicles with 2400 series transmissions, follow the instructions for vehicles with 1000 series transmissions.

15.05.08 Range Inhibit Indicator, 2000 and 2400 Series

A RANGE INHIBIT indicator is a standard feature of the 2000 series and 2400 series transmissions. The RANGE INHIBIT indicator comes on to alert the driver that transmission operation is being inhibited and that the range shifts being requested by the driver may not occur. When certain operating conditions are detected by the TCM (transmission control module), the controls will lock the transmission in the current operating range.

Shift inhibits occur under the following conditions:

- Shifts from neutral to reverse or from neutral to a forward range are not permitted when the engine is above idle (greater than 900 rpm).
- Forward/reverse directional shifts are typically not permitted if appreciable output shaft speed is detected.
- When some types of unusual transmission operating conditions are detected by the TCM, the TCM temporarily limits transmission operation until the vehicle can be driven to a service location. When this type of situation is detected, the TCM will lock the transmission in a safe gear range.
- The TCM will prevent shifts from park or neutral to range when auxiliary equipment, such as a power takeoff unit (PTO), is in operation.

15.05.09 Operating Instructions, On-Highway Transmissions

Allison automatic transmissions are electronically controlled. The shift selector provides five or six forward ranges and one reverse range.

P (Park, optional on 1000 and 2400 Series)

Use park when turning the engine on or off, to check vehicle accessories, to operate the engine in idle for longer than 5 minutes, and for stationary operation of the power takeoff, if equipped. This position places the transmission in neutral and engages the park pawl of the transmission.

NOTE: This does not apply the parking brake.

PB (Auto-Apply Parking Brake, optional on 2000 Series)

**WARNING:**

Before selecting PB on the shift lever, make sure the ignition switch is not in the OFF position. Selecting PB with the ignition switch in the OFF position places the transmission in neutral, but does not apply the parking brake automatically. The vehicle could roll unexpectedly, possibly causing property damage or personal injury.

The auto-apply parking brake places the transmission in neutral and applies the parking brake.

NOTE: Selecting PB on the shift lever does not engage the park pawl of the transmission.

R (Reverse)

Reverse is used to back the vehicle. When the selector is in reverse, the reverse warning signal will sound. Always bring the vehicle to a complete stop before shifting from a forward range to reverse, or from reverse to a forward range.

**NOTICE:**

Extended idling in reverse may cause transmission overheating and damage.

Do not idle in reverse for more than 5 minutes. Select P (park), PB (auto-apply parking brake), or N (neutral) when time at idle exceeds 5 minutes.

NOTE: The shift into reverse may not succeed if a range inhibitor is active. Check for illumination of the RANGE INHIBIT indicator.

N (Neutral)

The neutral position places the transmission in neutral. This position is used when starting the engine and for stationary operation.

**WARNING:**

Failure to apply the vehicle parking brakes when the transmission is in neutral may allow the vehicle to move unexpectedly, possibly causing property damage or personal injury.

When neutral is selected, the vehicle service brakes, parking brake, or emergency brake must be applied. Selecting neutral does not apply vehicle brakes unless an auxiliary system to apply the parking brake is installed.

**WARNING:**

Do not coast in neutral. Coasting in neutral can cause an accident, possibly resulting in severe personal injury or death.

Do not let the vehicle coast in neutral. If the vehicle is allowed to coast in neutral, the engine brake will not work and you could lose control of the vehicle.

**NOTICE:**

Coasting in neutral can cause severe transmission damage.

D (Drive)

**WARNING:**

When going downhill, use a combination of downshifting, braking, and other retarding devices to control vehicle speed and the engine's rated governed speed. Failure to do so could reduce vehicle braking, possibly causing loss of vehicle control and resulting in personal injury or property damage.

In the drive position, the transmission will initially go into first range when drive is selected. As vehicle speed increases, the transmission will upshift automatically through each available range up to fourth range or fifth range. As the vehicle slows, the transmission will downshift automatically.

When going downhill, downshift to a lower transmission range to increase engine braking and to help maintain control. The transmission has a feature to prevent automatic upshifting above the lower range selected. However, during downhill operation, the transmission may upshift to the next higher range, if the engine is exceeding its governed speed in the lower range.

**NOTICE:**

Do not idle in drive for more than 5 minutes. Extended idling in drive may cause transmission overheating and damage. Always select PB (auto-apply parking brake) or P (park) if time at idle is longer than 5 minutes.

NOTE: The shift into drive may not succeed if a range inhibitor is active. Check for illumination of the RANGE INHIBIT indicator.

4 and 3 (Fourth and Third Ranges, optional)

Use the fourth or third range for city traffic and for braking on steep downgrades.

3 and 2 (Third and Second Ranges, standard)

Use the third or second range for heavy city traffic and for braking on steeper downgrades.

1 (First Range)

Use first range when pulling through mud or deep snow, when maneuvering in tight spaces, or when driving up or down very steep grades. First range provides the vehicle with its maximum driving torque and maximum engine braking effect.

NOTE: To have the transmission select these ranges automatically, leave the selector lever in D (drive).

15.06 Allison Transmission® MD Series

15.06.01 Safety Precautions

Refer to the Allison website for additional information, www.allisontransmission.com.

**WARNING:**

Do not leave the vehicle unattended with the engine running. If you leave the vehicle and the engine is running, the vehicle can move suddenly, which could result in personal injury or property damage.

On vehicles with MD series transmissions, do the following steps if you have to leave the cab with the engine running (for example, when checking the transmission fluid):

1. Bring the vehicle to a complete stop using the service brake.
2. Put the transmission in N (neutral).
3. Ensure that the engine is at low idle (500 to 800 rpm).
4. Apply the parking brake and emergency brakes, and make sure they are properly engaged.
5. Chock the rear tires and take any other steps necessary to keep the vehicle from moving.

15.06.02 Operating Instructions, MD Series

The Allison MD transmission is electronically controlled and comes with a push-button shift control that provides five or six forward ranges and one reverse range. The push-button shift selector has an R (reverse), an N (neutral), a D (drive), an up arrow, a down arrow, a mode button, and a digital display.

New shift controls — known as fourth generation — were introduced in mid-2006. They replaced the previous units that are commonly referred to as WTEC III. See Fig.267, [WTEC III Push-Button Shift Selector](#) and see Fig. 268, [Fourth Generation Push-Button Shift Selector](#).

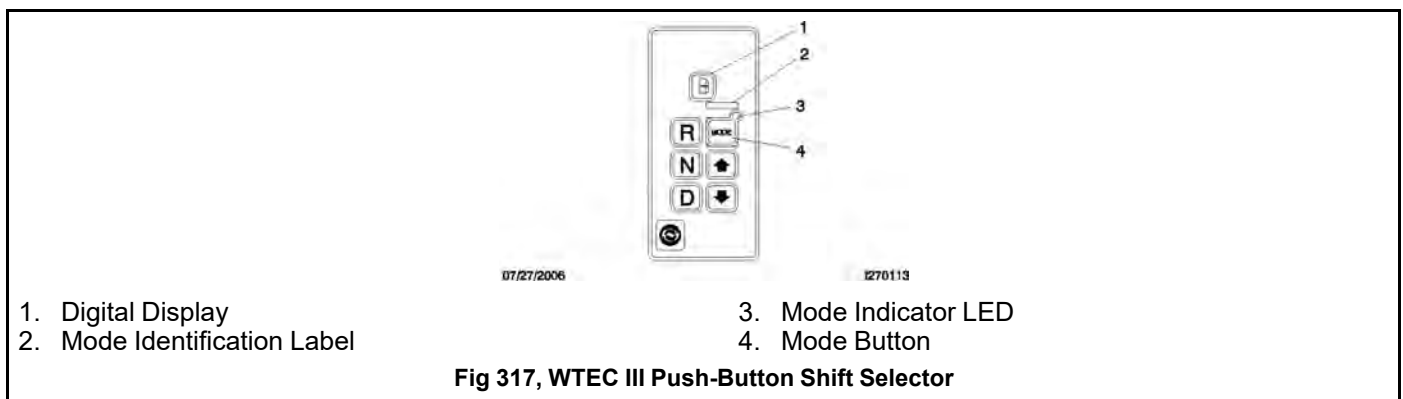

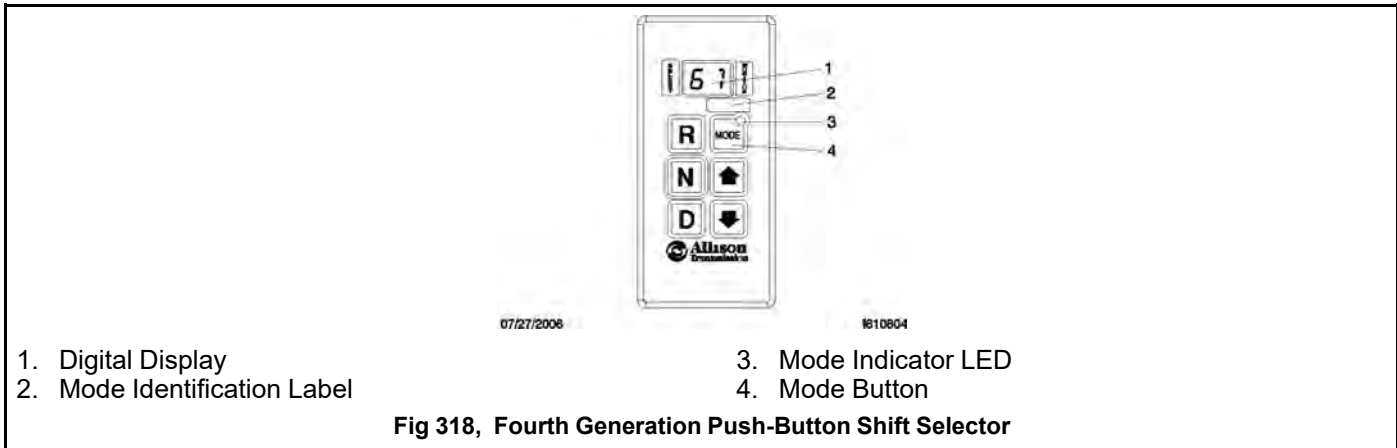

R (Reverse)

Press the R button to select reverse. The digital display will show R when reverse is selected. Always bring the vehicle to a complete stop and let the engine return to idle before shifting from a forward range to reverse, or from reverse to a forward range.



NOTICE:

Extended idling in reverse may cause transmission overheating and damage.

Do not idle in reverse for more than 5 minutes. Select neutral when time at idle exceeds 5 minutes.

NOTE: The shift into reverse may not succeed if a range inhibitor is active. When reverse is selected, always be sure that R is not flashing.

N (Neutral)



WARNING:

When starting the engine, make sure that the service brakes are applied. Failure to apply the service brakes may result in unexpected vehicle movement, which could cause severe personal injury or death. Failure to apply the vehicle parking brakes when the transmission is in neutral may allow the vehicle to move unexpectedly, possibly causing property damage or personal injury.

Press the N button to select neutral. The digital display will display N when neutral is selected. It is not necessary to press neutral before starting the vehicle. The ECU (electronic control unit) or TCM (transmission control module) automatically places the transmission in neutral at start-up.



WARNING:

Failure to apply the vehicle parking brakes when the transmission is in neutral may allow the vehicle to move unexpectedly, possibly causing property damage or personal injury.

When neutral is selected, the vehicle service brakes, parking brake, or emergency brake must be applied. Selecting neutral does not apply vehicle brakes unless an auxiliary system to apply the parking brake is installed.

**WARNING:**

Do not coast in neutral. Coasting in neutral can cause an accident, possibly resulting in severe personal injury or death.

Do not let the vehicle coast in neutral. If the vehicle is allowed to coast in neutral, the engine brake will not work and you could lose control of the vehicle.

Always select neutral before turning off the engine. Neutral is also used during stationary operation of the power takeoff if your vehicle is equipped with a PTO.

D (Drive)

When the D button is pushed, the highest forward range will appear in the display. The transmission will normally go into first range when drive is selected (except for those units programmed to start in second range). As vehicle speed increases, the transmission will upshift automatically through each range. As the vehicle slows, the transmission will downshift automatically.

**NOTICE:**

Do not idle in drive for more than 5 minutes. Extended idling in drive may cause transmission overheating and damage. Always select neutral if time at idle is longer than 5 minutes.

NOTE: The shift into drive may not succeed if a range inhibitor is active. When drive is selected, always be sure that D is not flashing.

5, 4, 3, and 2 (Fifth, Fourth, Third, and Second Ranges)

Occasionally, road conditions, load, or traffic conditions will make it desirable to restrict automatic shifting to a lower range. Lower ranges provide greater braking for going down grades. The lower the range, the greater the braking effect.

Push the up or down arrows on the push-button shift selector to select individual forward ranges. The digital display will display your choice of range. When a lower range is selected, the transmission may not downshift until the vehicle speed or engine RPM (engine governed speed) is reduced.

**WARNING:**

When going downhill, use a combination of downshifting, braking, and other retarding devices to control vehicle speed and the engine's rated governed speed. Failure to do so could reduce vehicle braking, possibly causing loss of vehicle control and resulting in personal injury or property damage.

When going downhill, downshift to a lower transmission range to increase engine braking and to help maintain control. The transmission has a feature to prevent automatic upshifting above the lower range selected. However, during downhill operation, if the engine governed speed is exceeded in the lower range, the transmission may upshift to the next higher range.

1 (First Range)

Use the first range when pulling through mud or deep snow, when maneuvering in tight spaces, or when driving up or down steep grades. First range provides the vehicle with its maximum driving torque and maximum engine braking effect. Push the down arrow until the first range appears on the display.

Up and Down Arrows

When a lower range is desired, after D has been pressed, press the down arrow until the desired range is shown on the display. Pressing the down arrow continuously causes the range position to continue to go down until the button is released or the lowest range is attained.

When the transmission is in drive and the down arrow has the transmission in a lower range position, press the up arrow to shift to a higher selector position. Pressing the up arrow continuously causes the range position to continue to rise until the button is released or the highest available position is attained.

Pressing the up or down arrows does not override the transmission automatic shifting operation. If a higher or lower position is selected, the transmission continues shifting through the ranges according to the vehicle operating characteristics until the highest or lowest selected position is reached.

Mode Button

The MODE button starts a specialized input or output function that has been previously programmed into the ECU or TCM. Pressing the MODE button changes transmission operation for a specific function.

Mode Indicator LED

When the MODE button is pressed, the mode indicator LED illuminates. A mode identification label, located above the MODE button, identifies the function associated with a mode change.

Digital Display

The dual digital display shows both the selected range (SELECT) and actual range attained (MONITOR). The single digital display shows the selected range.

Oil Level Sensor

Allison MD Series transmissions have an electronic oil level sensor to read fluid level information. The fluid level diagnostic will display whether the oil level is OK, too low, or too high. It will also display a default code and indicate if the preconditions (of receiving the fluid level information) are not met.

IMPORTANT: Maintain the proper fluid level at all times. If the fluid level is too low, the converter and clutch do not receive an adequate supply of fluid. If the level is too high, the transmission may shift erratically or overheat.

To access the oil level display mode, park the vehicle on a level surface, shift to N (neutral), apply the parking brake, and idle the engine. Then simultaneously press both the up and down arrows once. The oil level will display at the end of a two-minute countdown.

Diagnostic Codes

Diagnostic codes are numerical indications relating to a malfunction in transmission operation. These codes are logged in the TCM/ECU memory. The most severe or most recent code is listed first. A maximum of five codes (numbered d1-d5) may be listed in memory at one time. If the mode indicator LED is illuminated, the displayed code is active. If it is not illuminated, the displayed code is not active.

NOTE: During normal operation, an illuminated mode indicator LED signifies the specialized mode operation is in use.

To enter diagnostics mode, first park the vehicle and apply the parking brake. Then simultaneously press both the up and down arrows twice.

16.01 Eaton® Manual Transmissions	310
16.01.01 General Information	310
16.01.02 Transmission Operation Tips.....	310
16.02 Eaton® Straight-Shift Transmissions.....	310
16.02.01 General Information, Straight-Shift	310
16.02.02 Operation, Straight-Shift	311
16.03 Eaton® Range-Shift Transmissions	312
16.03.01 General Information, Range-Shift	312
16.03.02 Operation, Range-Shift.....	314
16.03.03 Upshifting	315
16.03.04 Downshifting.....	315
16.03.05 Operation, Deep-Reduction Models Upshifting	315
16.03.06 Operation, Deep-Reduction Models Downshifting.....	316
16.04 Clutch.....	316
16.04.01 General Information	316
16.04.02 Clutch Operation.....	317
16.04.03 Adjustment of the Clutch.....	318
16.05 Meritor MTC Series Transfer Cases	318
16.05.01 Meritor MTC Series	318
16.05.02 Shifting Between HIGH RANGE and LO RANGE.....	319
16.05.03 Engaging PTO	319

16. Manual Transmissions, Clutch, and Transfer Cases

16.01 Eaton® Manual Transmissions

16.01.01 General Information

A Freightliner M2 Plus vehicle may be equipped with an Eaton manual transmission. Vehicles with Eaton manual transmissions have clutch brakes and a hydraulic clutch actuation system.

The transmission shift pattern is printed on a decal attached to the driver-side sun visor or to the dash below the center dash panel. The shift pattern may also be printed on the shift knob.

NOTE: For additional information, refer to the Eaton website, <http://dtna.info/EatonTransmissionInfo>.

16.01.02 Transmission Operation Tips

Follow these important operation principles:

- For all conditions, use the highest gear that is still low enough to start the vehicle moving with the engine at or near idle speed, and without slipping the clutch excessively.
- When operating on-highway with no load or under ideal conditions, use 1st gear to start the vehicle moving forward.
- When operating off-road or under adverse conditions, use LOW gear to start the vehicle moving forward.
- Use the clutch brake to stop gear rotation when shifting into LOW or reverse while the vehicle is stationary. The clutch brake is actuated by depressing the clutch pedal all the way to the floor.
- Partially disengage the clutch to break engine torque during normal gear shifts.
- Double-clutch between all upshifts and downshifts that require movement of the shift knob. Splitting of gears does not require movement of the shift knob.
- Never push the range-preselection lever down into low range while operating in high range, except when downshifting from 5th gear to 4th gear.
- Do not shift from high range to low range at high vehicle speeds.
- Never make a range shift or a splitter shift while the vehicle is in reverse.
- Never move the range-preselection lever with the transmission in neutral while the vehicle is moving.
- Skip ratios while shifting *only* when operating conditions permit, depending on the load, grade, and road speed.
- Never coast with the transmission in neutral.

16.02 Eaton® Straight-Shift Transmissions

16.02.01 General Information, Straight-Shift

Refer to the Eaton website for additional information, <http://dtna.info/EatonTransmissionInfo>.

Eaton Fuller 5-speed FS models are fully synchronized. They have five forward speeds and one reverse. See Fig. 269, [Shift Pattern, 5-Speed FS Models](#) for the shift pattern.

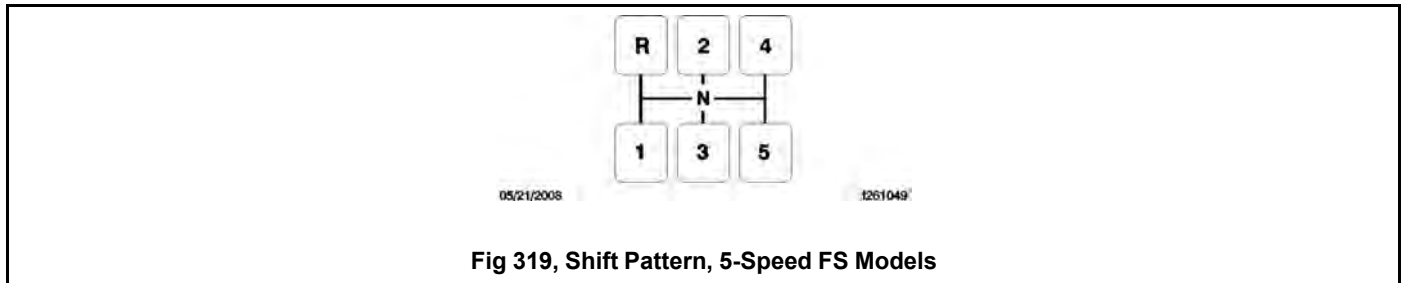

Eaton Fuller 6-speed FS and FSO models are fully synchronized. They have six forward speeds and one reverse. See Fig.270,[Shift Pattern, 6-Speed FS and FSO Models](#) for the shift pattern.

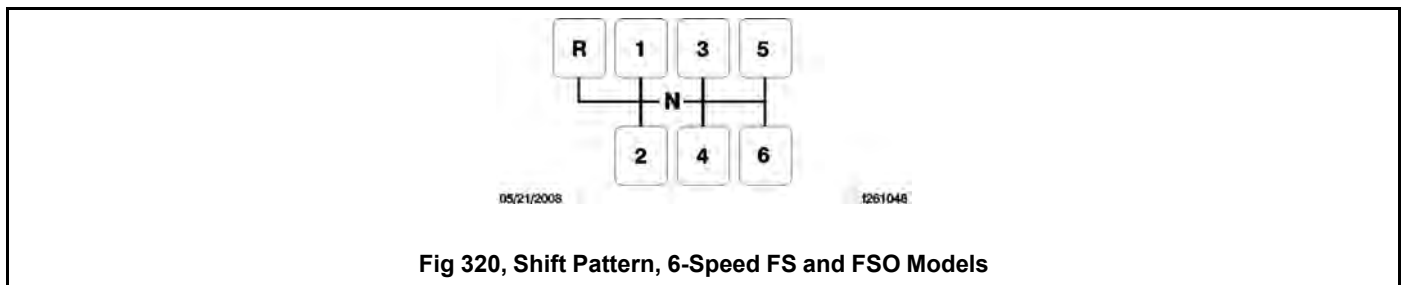

Eaton Fuller 7-speed T models are not synchronized. They have seven forward speeds and one reverse. See Fig. 271,[Shift Pattern, 7-Speed T Models](#) for the shift pattern.

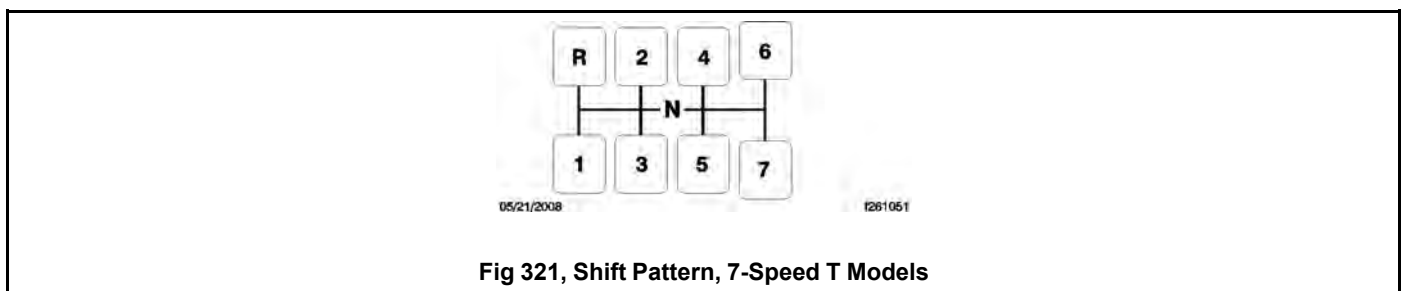

These transmissions are designed for use with on-highway, fuel economy engines where a minimum of shifting is desired and less gear reduction is acceptable.

16.02.02 Operation, Straight-Shift

1. Always use first gear when starting to move the vehicle forward.

IMPORTANT: Do not rest your foot on the clutch pedal while driving. This causes partial clutch disengagement which could cause premature clutch wear.

2. On synchronized models, press the clutch pedal to the floor when shifting gears. Double-clutching is unnecessary.

On unsynchronized models, press the clutch pedal to the floor to contact the clutch brake only when engaging the first or reverse gears.

NOTE: If the vehicle is moving when shifting, press the clutch pedal just far enough to disengage the clutch. Pressing it to the floor will engage the clutch brake, if so equipped, causing premature clutch brake wear.

3. To upshift, do the following steps:
 - 3.a Accelerate to engine governed speed.
 - 3.b On synchronized models, disengage the clutch and move the shift lever to second gear.
On unsynchronized models, disengage the clutch and move the shift lever to neutral. Engage the clutch again. With the shift lever in neutral, disengage the clutch and move the shift lever to second gear.
 - 3.c Engage the clutch and note the drop in engine rpm before accelerating up to engine governed speed again.
 - 3.d Continue upshifting using the same sequence described in the previous step. Follow the pattern on the shift lever.
4. To downshift, do the following steps:
 - 4.a Wait until the engine speed drops to the rpm noted immediately after the upshift.
 - 4.b On synchronized models, disengage the clutch and move the shift lever to the next lower gear.
On unsynchronized models, disengage the clutch and move the shift lever to neutral. Engage the clutch again. With the shift lever in neutral, disengage the clutch and move the shift lever to the next lowest gear.
 - 4.c Engage the clutch smoothly.
 - 4.d Use the sequence described above to shift progressively down through each successive lower gear, as driving conditions require.

16.03 Eaton® Range-Shift Transmissions

16.03.01 General Information, Range-Shift

Refer to the Eaton website for additional information, <http://dtna.info/EatonTransmissionInfo>.

Eaton Fuller 9-Speed Models

Eaton Fuller 9-speed range-shift models are not synchronized. They have nine forward speeds and two reverse speeds. The shift lever controls five forward gears and one reverse gear in the transmission front section, and the range lever controls a LO and HI range in the two-speed auxiliary section. The first position in the front section is used only as a starting gear. The other four ratios are used once in LO range and once again in HI range. See Fig. 272, [Shift Pattern, 9-Speed Models](#) for the shift patterns.

After shifting out of the first gear position, use the Roadranger® "repeat H" shift pattern. Select both LO range and HI range with the range lever (range knob). It is used once during the upshift sequence and once during the downshift sequence.

Always preselect the range shift. After preselection, the transmission will automatically make the synchronizer range shift as the shift lever passes through neutral.

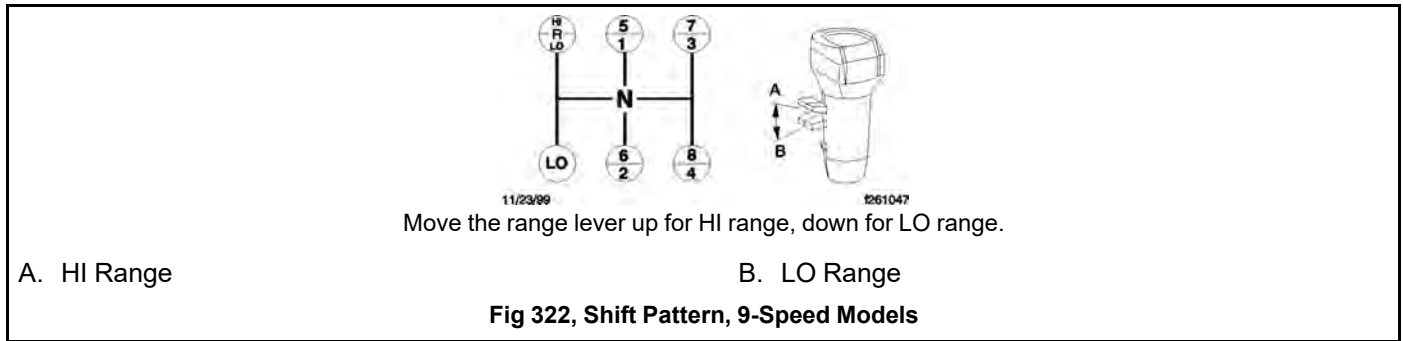

Move the range lever up for HI range, down for LO range.

Eaton Fuller 10-Speed Models

Eaton Fuller 10-speed range-shift models are not synchronized. They have ten forward speeds and two reverse speeds. The shift lever controls five forward gears and one reverse gear in the transmission front section, and the range lever controls a LO and HI range in the two-speed auxiliary section. The five forward gears selected in LO range are used again in HI range to provide the 10 progressive forward gears. See Fig.273, [Shift Pattern, 10-Speed Models](#) for the shift patterns. See Table.36, [Eaton Fuller Shift Progressions](#) for the shift progressions.

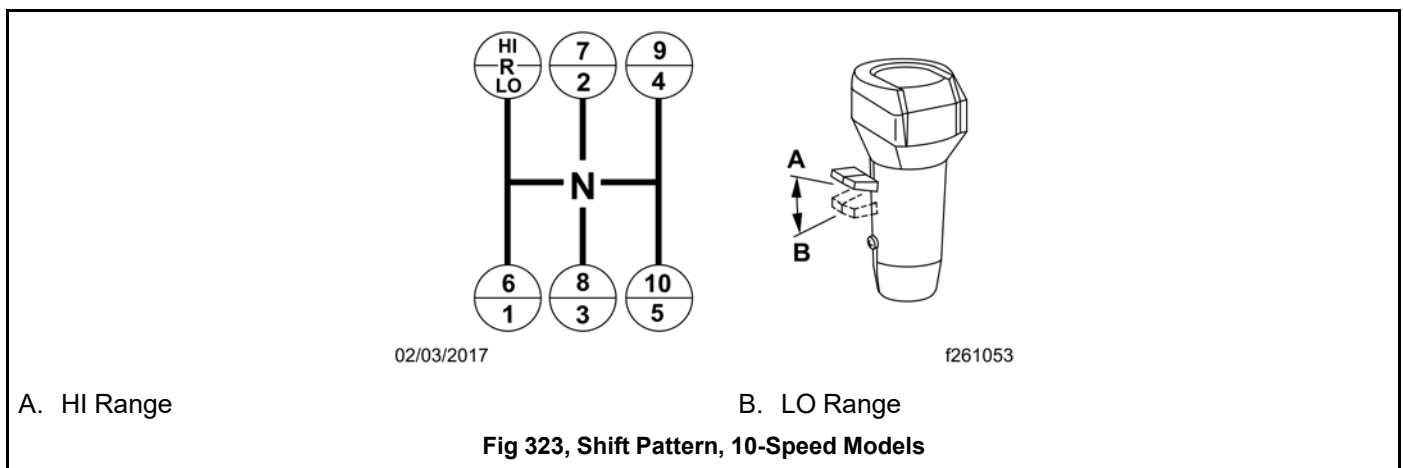

Once the highest shift lever position (fifth gear) is reached in LO range, the driver preselects the range shift lever for HI range. The range shift occurs automatically as the shift lever is moved from fifth gear position to the sixth gear position.



Eaton Fuller Shift Progressions			
Model	LO Range		HI Range
	Off-Highway	On-Highway	
9-Speed Direct or Overdrive			
10-Speed Direct or Overdrive			

Table 30, Eaton Fuller Shift Progressions

When downshifting, the driver preselects the range lever for LO range and the range shift occurs automatically during the shift lever movement to the next gear position.

Eaton Fuller Deep-Reduction Models

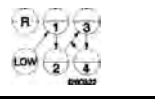
Eaton Fuller deep-reduction models are not synchronized. They have a five-speed front section and a two-speed auxiliary section which has an extra deep reduction gear. The LO gear in the front section is used only as a starting gear. The other four ratios are used once in LOW RANGE and once in HIGH RANGE giving eight highway ratios. LO-LO is selected by the DEEP REDUCTION lever on the dashboard. See Fig.274, [Shift Pattern, Deep Reduction](#) for the shift pattern.

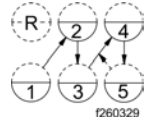
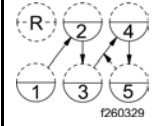
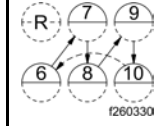
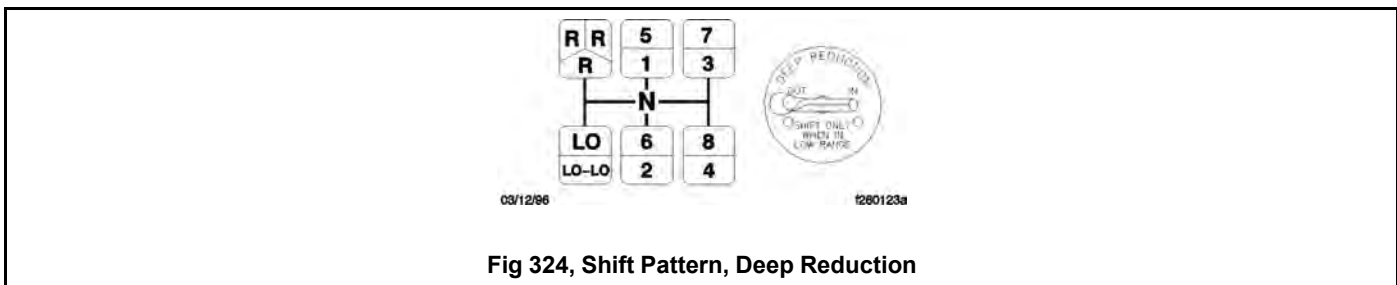

Fig 324, Shift Pattern, Deep Reduction

16.03.02 Operation, Range-Shift

1. When operating off-highway or under adverse conditions, always use low gear when starting to move the vehicle.

When operating on-highway, with no load or under ideal conditions, use first gear when starting to move the vehicle.

For all conditions, use the highest gear that is still low enough to start the vehicle moving with the engine idling and without excessively slipping the clutch.

2. Use the clutch brake to stop gear rotation when shifting into low (or first) or reverse when the vehicle is stationary. The clutch brake is applied by pressing the clutch pedal all the way to the floor.

For normal upshifts and downshifts, only a partial disengagement of the clutch is necessary to break engine torque.

3. Do not make range shifts with the vehicle moving in reverse gear.
4. Never attempt to move the range preselection lever with the gear shift lever in neutral while the vehicle is moving. Preselection with the range preselection lever must be made prior to moving the shift lever out of gear into neutral.

5. Do not shift from high range to low range at high vehicle speeds.
6. Use double-clutching between all upshifts and downshifts.
7. After your shifting ability improves, you may want to skip some of the ratios. This may be done only when operating conditions such as load, grade, and road speed permit.

16.03.03 Upshifting

1. Position the gear shift lever in neutral. Start the engine and bring the air system pressure up to 100 to 120 psi (689 to 827 kPa).
2. Position the range preselection lever down into low range.
3. Press the clutch pedal to the floor. Shift into low or first gear, then engage the clutch with the engine at or near idle speed to start the vehicle moving. Accelerate to 80 percent of engine governed speed.
4. Shift progressively up from low or 1st gear to the top gear in low range, double-clutching between shifts and accelerating to 80 percent of engine governed speed.
5. While in the top gear of the low-range shift pattern and ready for the next upshift, flip the range preselection lever up into high range. Double-clutch through neutral and shift into the bottom gear in high range. As the shift lever passes through neutral, the transmission will automatically shift from low range to high range.
6. With the transmission in high range, shift progressively up through each of the high range gears, double-clutching between shifts.

16.03.04 Downshifting

1. With the transmission in high range, shift progressively down to the bottom gear in high range, double-clutching between shifts.
2. When in the bottom gear of the high-range shift pattern and ready for the next downshift, push the range preselection lever down into low range. Double-clutch through neutral and shift into the top gear of the low-range shift pattern. As the shift lever passes through neutral, the transmission will automatically shift from high range to low range.
3. With the transmission in low range, downshift through the low range gears as conditions require.

Never use the clutch brake when downshifting or as a brake to slow the vehicle.

16.03.05 Operation, Deep-Reduction Models Upshifting

1. Position the gear shift lever in neutral. See Fig.275, [Shift Pattern, Deep Reduction](#) for the shift pattern. Start the engine, and bring the air system pressure up to 95 to 125 psi (655 to 862 kPa).
2. Position the range preselection lever down, into low range.

NOTE: If conditions are difficult, start out in LO-LO. Move the DEEP REDUCTION lever on the dashboard to the IN position. Otherwise start out in LO with the DEEP REDUCTION lever in the OUT position.

3. Depress the clutch pedal to the floor. Shift into LO gear; then, engage the clutch, with the engine at or near idle rpm to start the vehicle moving. The vehicle will start in LO or LO-LO depending on the DEEP REDUCTION lever position.
4. To upshift if in LO-LO, move the DEEP REDUCTION lever to the OUT position and *immediately* release the accelerator, depress the clutch pedal once to break torque, and reengage the clutch. The auxiliary section will shift from LO-LO to LO when the gears reach the same speed.
5. Shift progressively upward from LO through 1st, 2nd, 3rd, and 4th gears while the range preselection lever is in LO. Always double-clutch between gears.
6. When in 4th gear and ready for the next upshift, pull up the range preselection lever and move the shift lever, double-clutching, to the 5th gear position. As the shift lever passes through neutral, the auxiliary section will automatically shift from low to high range.

**NOTICE:**

Never move the shift lever into the LO gear position after high range preselection or anytime the auxiliary section is in high range. Transmission damage could result.

- Continue upshifting from 5th gear through 8th gear, always double-clutching between gears.

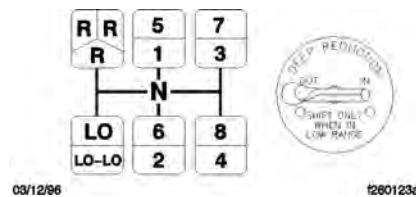

Fig 325, Shift Pattern, Deep Reduction

16.03.06 Operation, Deep-Reduction Models Downshifting

- While in high range, move the gear shift lever from 8th gear through 5th gear as conditions require, always double-clutching between gears.
- When in 5th gear and ready for the next downshift, push down the range preselection lever and move the shift lever to the 4th gear position, being sure to double-clutch. As the shift lever passes through neutral, the auxiliary section will automatically shift from high to low range.
- While in the low range, continue downshifting from 4th through LO as conditions require, always double-clutching between gears.
- Do not* downshift into LO-LO from LO unless operating conditions make it necessary. If it is necessary, make sure that the shift lever is in the LO gear position and the auxiliary section is in the low range. Then, move the DEEP REDUCTION lever on the dashboard to the IN position. *Immediately* release the accelerator, depress the clutch pedal once to break torque, engage the clutch, and accelerate. The auxiliary section will automatically shift from LO to LO-LO when the gears reach the same speed.

**NOTICE:**

Never use the clutch brake when downshifting, or as a brake to slow the vehicle. This will cause premature clutch brake wear.

16.04 Clutch

16.04.01 General Information

The hydraulic clutch control system consists of a pedal unit and a slave cylinder connected by a hydraulic hose. The components of the system have been specially designed to use DOT 4 brake fluid. The hydraulic system is self-adjusting.

Typical operation will not break down the clutch friction surfaces. Heat and wear are almost nonexistent when a clutch is fully engaged. However, during the moment of engagement, when the clutch is picking up the load, considerable heat is generated. If a clutch slips excessively, high temperatures develop quickly between the flywheel, driven discs, and pressure plates. An improperly adjusted or slipping clutch can generate temperatures high enough to cause the friction-facing material to char and burn, destroying the clutch.

To ensure long service life of the clutch, start in the right gear and be alert to clutch malfunctions.

16.04.02 Clutch Operation

Clutch Break-In

With a new or newly installed clutch, the clutch may slip for a short time while the friction surfaces break-in. However, allowing the clutch to slip for more than two seconds can severely damage the clutch disc, pressure plate, and the flywheel.

During initial operation of a new vehicle or a vehicle with a new clutch, check for clutch slippage during acceleration. If the clutch slips, decelerate until the clutch does not slip. Allow the clutch to cool 15 to 30 seconds, and then gradually accelerate again. If the clutch continues to slip, repeat the procedure. If necessary, repeat the procedure up to five times. If the clutch slips after five attempts, stop the vehicle. Allow the clutch to cool for at least one hour. Notify your Freightliner dealer of the problem.

**NOTICE:**

Do not allow sustained slippage of the clutch; this could severely damage the clutch disc, pressure plate, or flywheel. Damage caused by clutch slippage due to improper break-in is not warrantable.

Using the Clutch Brake

The clutch brake is applied by depressing the clutch pedal past the fully released clutch position, almost to the floor plate. The last part of the clutch pedal travel will compress the clutch brake plates together, stopping the transmission input shaft. The purpose of the clutch brake is to stop the transmission gears from rotating in order to quickly engage a transmission gear after idling in neutral.

**NOTICE:**

Never apply the clutch brake when the vehicle is moving. If the clutch brake is applied when the vehicle is moving, the clutch brake will try to stop or decelerate the vehicle, causing rapid wear of the clutch brake friction discs. Considerable heat will be generated, causing damage to the release bearings and the transmission front bearings.

Holding the Vehicle on an Incline

Always use the vehicle service brakes to prevent the vehicle from rolling backwards while stopped on a hill. Slipping the clutch on a hill to maintain the vehicle position will quickly damage the clutch assembly.

Coasting

Coasting with the clutch pedal depressed and the transmission in a low gear can cause high driven disc speed. The clutch speed can be much higher under these conditions than when the engine is driving the clutch. This condition creates a hazardous situation due to the lack of vehicle control and due to the high clutch disc speed. Engaging the clutch under these conditions can cause component damage because of the shock loads to the clutch and drivetrain.



WARNING:

Always shift into the gear that is correct for the traveling speed of the vehicle and engage the clutch. Coasting with the clutch disengaged can prevent engagement of the correct transmission gear which can cause loss of vehicle control, possibly resulting in personal injury or property damage.

High clutch disc speeds while coasting can also cause the clutch facing to be thrown off the disc. Flying debris from the clutch can cause injury to persons in the cab.

16.04.03 Adjustment of the Clutch

Eaton Fuller Solo clutches are adjustment-free. As the clutch wears, its wear-adjusting technology monitors clutch components and makes any necessary adjustments. The wear adjusting technology comes from two sliding cams, which rotate to maintain the proper adjustment. Atop the upper cam, a wear indicating tab mirrors the cam's movement, letting you know when it's time to replace the clutch.

16.05 Meritor MTC Series Transfer Cases

16.05.01 Meritor MTC Series

Some vehicles are equipped with a Meritor MTC Series transfer case for part-time 4x4, 6x6, or 8x8 operation. Meritor MTC Series transfer cases have two gear sets: HIGH RANGE and LO RANGE.



WARNING:

Do not engage a Meritor MTC Series transfer case when driving on normal highway conditions. Severe personal injury and/or damage to components can result when the transfer case is misused.

IMPORTANT: Steer axle engagement is limited to 20 percent or less of annual vehicle mileage.

Follow the operating guidelines in **Table 15.2** when driving a vehicle equipped with a Meritor MTC transfer case.

Engaging and Disengaging the Steer Axle

Dash-mounted switches control the transfer case functions; see [5.01 Ignition Switch and Key](#) for more information.

IMPORTANT: The wheels must not slip during engagement of the steer axle driveline.

To engage the steer axle driveline, drive the vehicle at a constant speed below 10 mph (16 km/h) and press the AWD switch. An audible engagement may be heard.

To disengage the steer axle, drive the vehicle at a constant speed below 10 mph (16 km/h) and press the AWD switch. An audible disengagement may be heard. If the steer axle driveline does not disengage, the steer axle driveline coupling may be in a bind. Turn the steering wheel back and forth while driving, or briefly drive the vehicle in reverse.

Range	Disengaged Steer Axle		Engaged Steer Axle	
	Traction Conditions	Applicable Vehicle Speeds	Traction Conditions	Applicable Vehicle Speeds
HIGH RANGE	Most normal driving conditions (such as dry or wet pavement or mixed road surfaces)	0 mph (0 km/h) to maximum vehicle speed	When more traction is needed at moderate to low vehicle speeds on dirt or gravel surface	20 mph (32 km/h) or less

Table 37, Operating Guidelines, Meritor MTC Transfer Cases

	when moderate to high vehicle speeds are appropriate.		with shallow to moderate grades (8% maximum), icy or snow-covered roads, or hard-packed sand.	
LO RANGE	Not applicable. Do not use LO RANGE unless the steer axle is engaged.		When maximum power and maximum traction is needed on steeper grades (15% maximum), deeply rutted tracks, deep mud or snow, extremely rocky surfaces, or soft, loamy sand.	15 mph (24 km/h) or less
IMPORTANT: Engaging the steer axle will increase the turning radius of the vehicle.				

Table 31, Operating Guidelines, Meritor MTC Transfer Cases

16.05.02 Shifting Between HIGH RANGE and LO RANGE

MTC Series transfer cases use an air cylinder to shift between HIGH RANGE and LO RANGE. A dash-mounted switch operates the shift mechanism (see [5.01 Ignition Switch and Key](#) for more information).

Shift between HIGH RANGE and LO RANGE, as follows:

1. Stop the vehicle.
2. Shift the transmission to NEUTRAL.
3. Apply the parking brake.
4. Move the dash-mounted switch to the HIGH or LO RANGE position to pressurize the shift mechanism in the transfer case. An audible engagement may be heard (which is normal).
5. Shift the transmission to FIRST gear and apply light torque to test the engagement.

If the shifter does not engage when shifting from HIGH RANGE to LO RANGE, shift the transmission into REVERSE, then NEUTRAL, and apply light torque to engage the LO RANGE.

16.05.03 Engaging PTO

Some vehicles are equipped with a PTO mounted to a Meritor MTC transfer case. For these vehicles, engage the PTO only when the transfer case is in neutral, the transmission is in neutral/park, and the parking brake is applied. To begin using the PTO, select the drive gear based on the PTO system operators manual.

17.01 Meritor™ Drive Axles.....	322
17.01.01 Drive Axles With Differential Lock.....	322
17.01.02 Tandem Drive Axles With Interaxle Lock	324
17.01.03 Axle Shift.....	325
17.02 Driver-Controlled Differential Lock (DCDL)	326
17.02.01 General Information	326
17.02.02 Differential Lock Switch	327
17.02.03 DCDL Operation	328
17.02.04 Single Drive Axles with Traction Equalizer.....	329
17.01 General Information	329
17.02 Interaxle Lock Switch	330
17.03 Interaxle Lock Operation	331

17. Drive Axles

17.01 Meritor™ Drive Axles

17.01.01 Drive Axles With Differential Lock

Refer to the Meritor website for additional information, www.meritor.com.

The Meritor driver-controlled differential lock feature (side-to-side wheel lock, traction control, or traction equalizer) is available on single-drive or dual-drive rear axles. It is available on both axles of a dual-drive vehicle, or on one only. It is only available on drive axles. Differential lock must only be used under adverse road conditions where greater traction is needed. With differential lock on, the turning radius is increased and vehicle handling is affected. The differential lock switch, shown in Fig.276, [Differential Lock Switch](#), allows the driver to lock the wheels on the same axle together. The red differential lock warning light illuminates on the dash message center when differential lock is engaged.



Fig 326, Differential Lock Switch

Differential lock provides maximum traction under slippery conditions. When the differential lock is engaged, the clutch collar completely locks the differential case, gearing, and axle shafts together, maximizing the traction of both wheels and protecting against spinout.

Under normal traction conditions, do not use the differential lock feature.

Differential Lock Switch



NOTICE:

Differential lock should only be engaged when the vehicle is stopped or moving slowly at low throttle. This will prevent internal axle damage.

Normally, when differential lock is available on dual-drive vehicles, one switch activates the lock on both rear drive axles. As an option, it is possible to have two differential lock switches, one for the forward rear and one for the rearmost drive axle. It is also possible for some vehicles to have differential lock on only one of the drive axles.

A two-position guarded rocker switch, shown in Fig.276, [Differential Lock Switch](#), controls differential lock, causing the wheels on each axle governed by the switch to rotate together. To lock the wheels together, press the upper half of the rocker momentarily (at the red LED). To unlock the wheels, press the upper half of the rocker again.

IMPORTANT: The differential lock rocker switch is guarded to prevent unintentional switch activation. If the LED in the switch begins to blink during normal operation, when the switch has not been activated, this indicates an error condition. Bring the vehicle to an authorized Freightliner service facility as soon as possible.

When the differential lock switch is pressed, three responses are possible: a normal response, a slow response, and an abnormal response.

Normal Response: The LED in the switch blinks until the axle has responded to the request to lock the wheels. At this point, the LED comes on steady and stays illuminated. In normal operation, the wheels may lock so quickly that the blinking of the switch is barely noticeable.

If operation of the switch is not possible for any reason (ignition is turned off, vehicle is moving faster than 25 mph, etc.), the LED will stop blinking and turn off.

Slow Response: If operation of the switch is slowed for any reason (vehicle moving too fast, low air pressure, etc.), the switch will continue to blink until the wheels are able to lock. As in the normal response, the LED comes on steady and stays illuminated once the wheels have locked.

NOTE: If the vehicle is moving too fast, let up slightly on the accelerator. As the vehicle slows, the wheels will lock.

Abnormal Response: If the LED blinks for more than 30 seconds, the lock mechanism may not be fully engaged/disengaged. Bring the vehicle to an authorized Freightliner service facility for testing.

Differential Lock Operation



WARNING:

Locking the wheels when the vehicle is traveling down steep grades or when the wheels are slipping could damage the differential and/or lead to loss of vehicle control, causing personal injury and property damage.

Lock the wheels only when the vehicle is standing still or moving at very low speed, less than 5 mph (8 km/h). Never lock the wheels when the vehicle is traveling down steep grades or when the wheels are slipping.

NOTE: On some vehicles, the differential lock system is connected through the low speed range of the transmission. If this system is used, the transmission must be in the low speed range for the wheels to fully lock.



WARNING:

A vehicle with locked wheels can still slip sideways, causing possible loss of vehicle control, personal injury, and property damage.

Be especially careful when driving under slippery conditions with the wheels locked. Though forward traction is improved, the vehicle can still slip sideways.

If the vehicle is moving, maintain a constant vehicle speed when the differential lock is turned on. Briefly let up on the accelerator to relieve torque on the gearing, allowing the wheels to lock completely. When the wheels are fully locked, the turning radius will increase because the vehicle understeers. See Fig.277, [Turning Radii](#). Drive cautiously and do not exceed 25 mph (40 km/h).

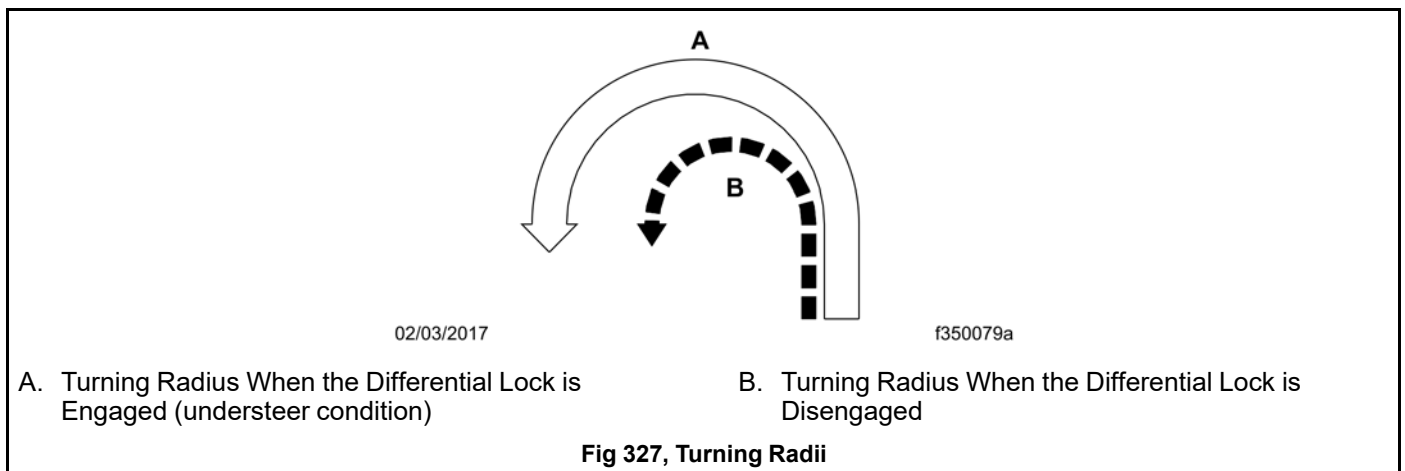

To disengage differential lock after leaving poor road conditions, operate the differential lock switch as discussed above while maintaining vehicle speed. Let up momentarily on the accelerator to allow the wheels to fully unlock, then resume driving at normal speed.

NOTE: If the differential lock system is connected with the transmission in its low speed range, shifting out of the low speed range will also disengage the differential lock function. The switch will blink until the wheels unlock, and then go out.

17.01.02 Tandem Drive Axles With Interaxle Lock



NOTICE:

The interaxle lock should not be engaged on a vehicle with obviously spinning wheels. Engagement at high speed or power can damage the axle(s).

Meritor has an interaxle lock (axle lock, interaxle differential lockout) feature that is standard on all dual-drive (tandem-drive) vehicles. Interaxle lock is recommended for use under adverse road conditions where greater traction is needed. See the axle manufacturer's manual provided with the vehicle for more information.

The interaxle lock switch, shown in Fig.278, [Interaxle Lock Switch](#), allows the driver to lock both rear axles together. The red interaxle warning light illuminates on the dash message center when interaxle lock is engaged.



Fig 328, Interaxle Lock Switch

When the interaxle lock is not engaged, there is differential action between the two axles. The differential compensates for different wheel speeds and variations in tire size. Keep the interaxle lock disengaged when driving on roads where traction is good.

When the interaxle lock is engaged, the differential action between the two axles is locked. Both drive axles now share the power. Both axles, and both sets of wheels, turn together at the same speed. The interaxle lock should be used when the vehicle encounters poor traction conditions; however, it also increases drivetrain and tire wear and should be used only when improved traction is required.

Interaxle Lock Switch

A two-position guarded rocker switch, shown in Fig.278, [Interaxle Lock Switch](#), controls interaxle lock, causing both axle shafts to rotate together. To lock the axles together, press the upper half of the rocker momentarily (at the red LED). To turn off interaxle lock, press the lower half of the rocker (at the double-axle icon).

IMPORTANT: The interaxle lock rocker switch is guarded to prevent unintentional switch activation. This switch does not have a diagnostic blink function when inactive.

When the interaxle lock switch is pressed, three responses are possible: a normal response, a slow response, and an abnormal response.

Normal Response: The LED in the switch blinks until the interaxle lock is engaged. At this point, the LED comes on steady and stays illuminated. In normal operation, the interaxle may lock so quickly that the blinking of the switch is barely noticeable.

If operation of the switch is not possible for any reason (ignition is turned off, vehicle is moving too fast, etc.), the LED will stop blinking and turn off.

Slow Response: If operation of the switch is slowed for any reason (by cold weather, low air pressure, etc.), the switch will continue to blink until the axles lock together, or for a maximum of 10 seconds. As in the normal response, the LED comes on steady and stays illuminated.

Abnormal Response: If the LED blinks for more than 30 seconds, the lock mechanism may not be fully engaged/disengaged. Bring the vehicle to an authorized Freightliner service facility for testing.

Interaxle Lock Operation

To engage interaxle lock and achieve maximum pulling power in slippery or hazardous road conditions, operate the interaxle lock switch as discussed above, while maintaining vehicle speed. Let up momentarily on the accelerator until the axle lock engages. Proceed over poor road conditions with caution. Do not wait until traction is lost and the tires are spinning before engaging the interaxle lock.



NOTICE:

Do not turn on the interaxle lock switch when the tires are slipping. Do not continuously operate the vehicle with the interaxle lock engaged during good road conditions. To do so could result in damage to the axle gearing and excessive tire wear.

To disengage the interaxle lock after leaving poor road conditions, operate the interaxle lock switch as discussed above while maintaining vehicle speed. Let up momentarily on the accelerator to allow the axles to fully unlock, then resume driving at normal speed.

17.01.03 Axle Shift



NOTICE:

To prevent transmission and axle damage, make sure the automatic transmission is in high range when performing an axle shift with the vehicle moving.

Axle shift is a function installed on vehicles with two-speed axles to allow the use of the low speed range when greater traction and maximum pulling power is needed at low engine speed (rpm).

Under normal operating conditions, the vehicle is operated using the high-speed gear ratios of the axle. Under extreme weather or off-road conditions, at low speed and rpm and/or to pull heavy loads, the vehicle must be operated using the low-speed, or reduction, gear ratios of the axle.

Axle Shift Switch

The axle shift switch is a two-position guarded rocker switch installed on vehicles with two-speed axles. See Fig. 279, [Axle Shift Switch](#).

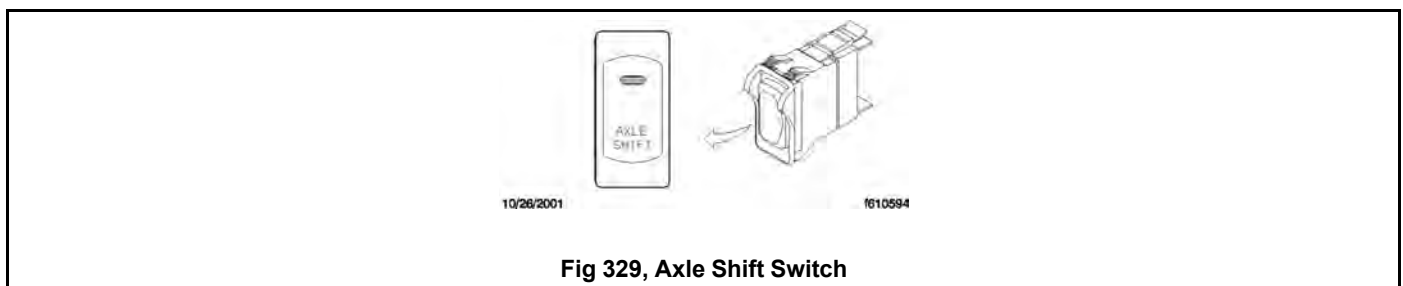

Fig 329, Axle Shift Switch

To shift the axle from low speed to high speed, press the upper half of the rocker momentarily (at the LED). To turn the axle shift off (switch from high speed back to low speed), press the upper half of the rocker again. When the axle has shifted speed, the LED turns off.

When the panel lights are on, the AXLE SHIFT legend is backlit in green.

IMPORTANT: The axle shift rocker switch is guarded to prevent unintentional switch activation. If the LED in the switch begins to blink during normal operation, when the switch has not been activated, this indicates an error condition. Bring the vehicle to an authorized Freightliner service facility as soon as possible.

When the axle shift switch is pressed, three responses are possible: a normal response, a slow response, and an abnormal response.

Normal Response: The LED in the switch blinks until the axle shifts speed. At this point, the LED comes on steady and stays illuminated. In normal operation, the axle may shift so quickly that the blinking of the switch is barely noticeable.

If operation of the switch is not possible for any reason (interaxle lock is on, ignition is turned off, etc.), the LED will stop blinking and turn off.

Slow Response: If operation of the switch is slowed for any reason (by cold weather, low air pressure, etc.), the switch will continue to blink until the axle shifts. As in the normal response, the LED comes on steady and stays illuminated.

Abnormal Response: If the LED blinks for more than 30 seconds, the axle shift function/mechanism may not be operating correctly. Bring the vehicle to an authorized Freightliner service facility for testing.

Axle Switch Interlock

NOTE: On vehicles with tandem drive axles, there is an interlock that prevents an axle from shifting speed whenever the interaxle lock is on.

If the axle shift switch is pressed when the interaxle lock is on, the axle shift will not be completed. The LED does the following:

- If the LED is off, the LED comes on briefly and turns off again.
- If the LED is on, it stays on.

To complete the axle shift, turn off the interaxle lock and press the axle shift switch again. If still needed, the interaxle lock can then be reactivated.

17.02 Driver-Controlled Differential Lock (DCDL)

17.02.01 General Information

The driver-controlled differential lock (DCDL) feature (side-to-side wheel lock, traction control, or traction equalizer) is available on vehicles with single- or tandem-drive axles.

The DCDL provides maximum traction for slippery conditions by forcing the wheels on each drive axle governed by the switch to rotate together. When the DCDL is engaged, the clutch collar completely locks the differential case, gearing, and axle shafts together, maximizing the traction of both wheels. Use the DCDL if the interaxle lock does not provide sufficient traction.

A status screen showing engaged locks is found in the vehicle operations menus on the driver display. See Fig. 280, [Interaxle and Differential Locks Status Screen](#).

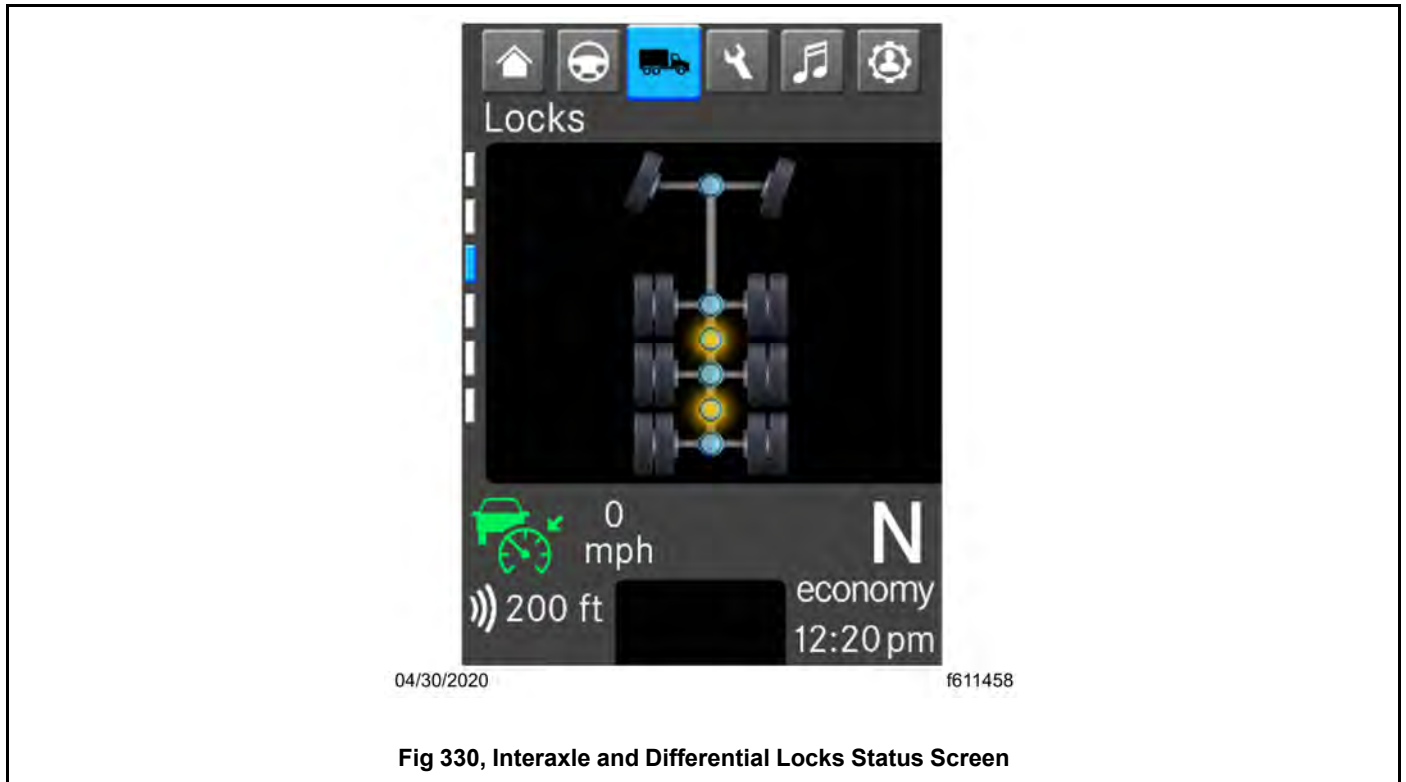

Fig 330, Interaxle and Differential Locks Status Screen

17.02.02 Differential Lock Switch

Each differential lock is controlled by a switch on the dash. See Fig.282, [Axle Switches](#).

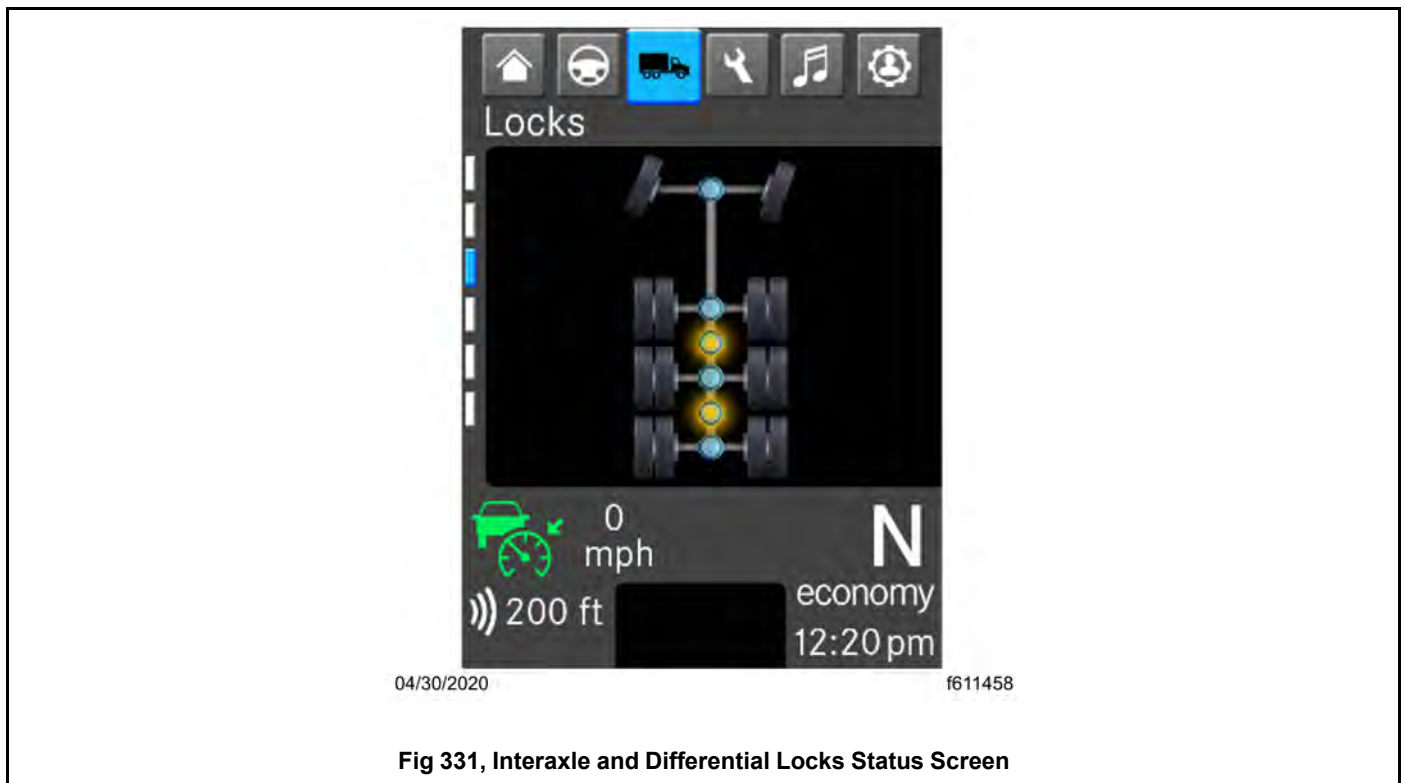
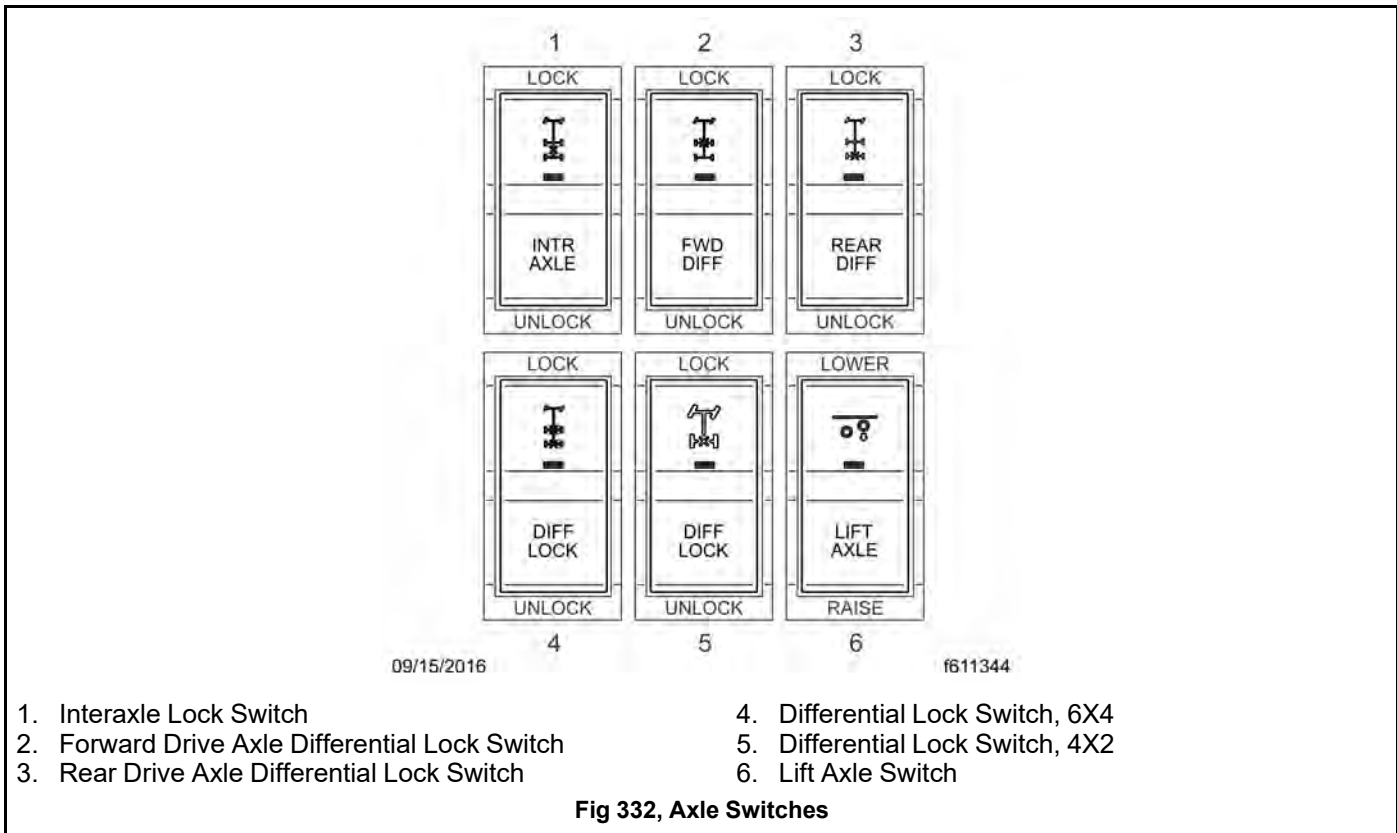

Fig 331, Interaxle and Differential Locks Status Screen



17.02.03 DCDL Operation



WARNING:

Locking the wheels when the vehicle is traveling down steep grades or when the wheels are slipping could damage the differential and/or lead to loss of vehicle control, causing personal injury and property damage.



NOTICE:

Engage the DCDL only when the vehicle is stopped or moving at less than 5 mph (8 km/h). Engaging the DCDL at speeds above 5 mph (8 km/h) can cause internal axle damage.

NOTE: On some vehicles, the differential lock system is connected through the low speed range of the transmission. If this system is used, the transmission must be in the low speed range for the wheels to fully lock. In addition, shifting out of low speed range will also disengage the differential lock.

NOTE: If the DCDL is engaged when the engine is shut down, the DCDL will disengage.

1. With the engine running, press the upper half of the differential lock switch to engage the DCDL.

- If the vehicle is moving, briefly let up on the accelerator to relieve torque on the gearing, allowing the differential to fully lock. An indicator light on the differential lock switch illuminates when the lock is engaged. Depending on the vehicle configuration, a buzzer may also sound.

**WARNING:**

Be especially careful when driving under slippery conditions with the differential locked. Though forward traction is improved, the vehicle can still slip sideways, causing possible loss of vehicle control, personal injury, and property damage.

- Drive cautiously and do not exceed 25 mph (40 km/h). When the differential is fully locked, the turning radius will increase because the vehicle understeers. See Fig.283, [Turning Radii](#).

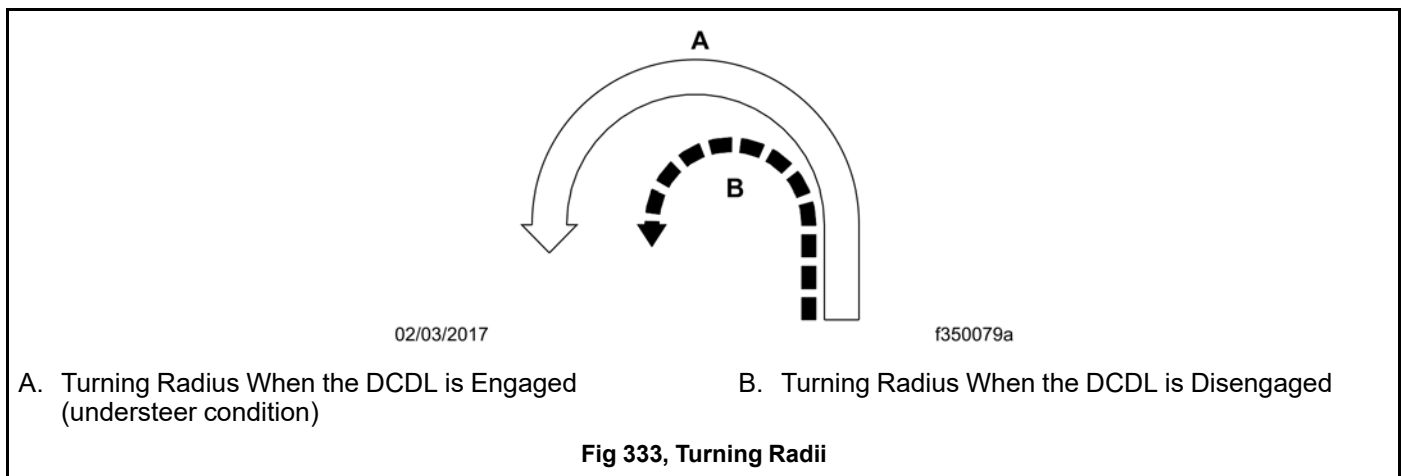

- Press the lower half of the differential lock switch to disengage the DCDL after leaving poor road conditions.
- If the vehicle is moving, briefly let up on the accelerator to allow the wheels to fully unlock, then resume driving at normal speed.

17.02.04 Single Drive Axles with Traction Equalizer

Some single drive axles are equipped with a traction equalizer that is a load-sensing, self-actuating feature. A traction equalizer provides normal differential action where traction is good. When one wheel begins to spin faster than the other, clutch plates in the differential housing automatically engage, delivering power to both wheels. There is no operator control with this feature.

**NOTICE:**

Tire sizes on both rear wheels should be the same on axles equipped with a traction equalizer. If not, excessive wear may occur in the traction equalizer.

17.01 General Information

The interaxle lock (axle lock, interaxle differential lockout) feature causes the drive axle shafts to rotate together, and is recommended for use under adverse road conditions where greater traction is needed.

When engaged, the interaxle lock essentially makes the driveshaft a solid connection between the drive axles. Power entering the forward axle is transmitted straight through to the rearmost axle(s). Driveline torque is now delivered equally and the drive axles, and wheels, turn together at the same speed. The interaxle lock increases drivetrain and tire wear and should be used only when improved traction is required.

A status screen showing engaged locks is found in the vehicle operations menus on the driver display. See Fig. 284, [Interaxle and Differential Locks Status Screen](#).

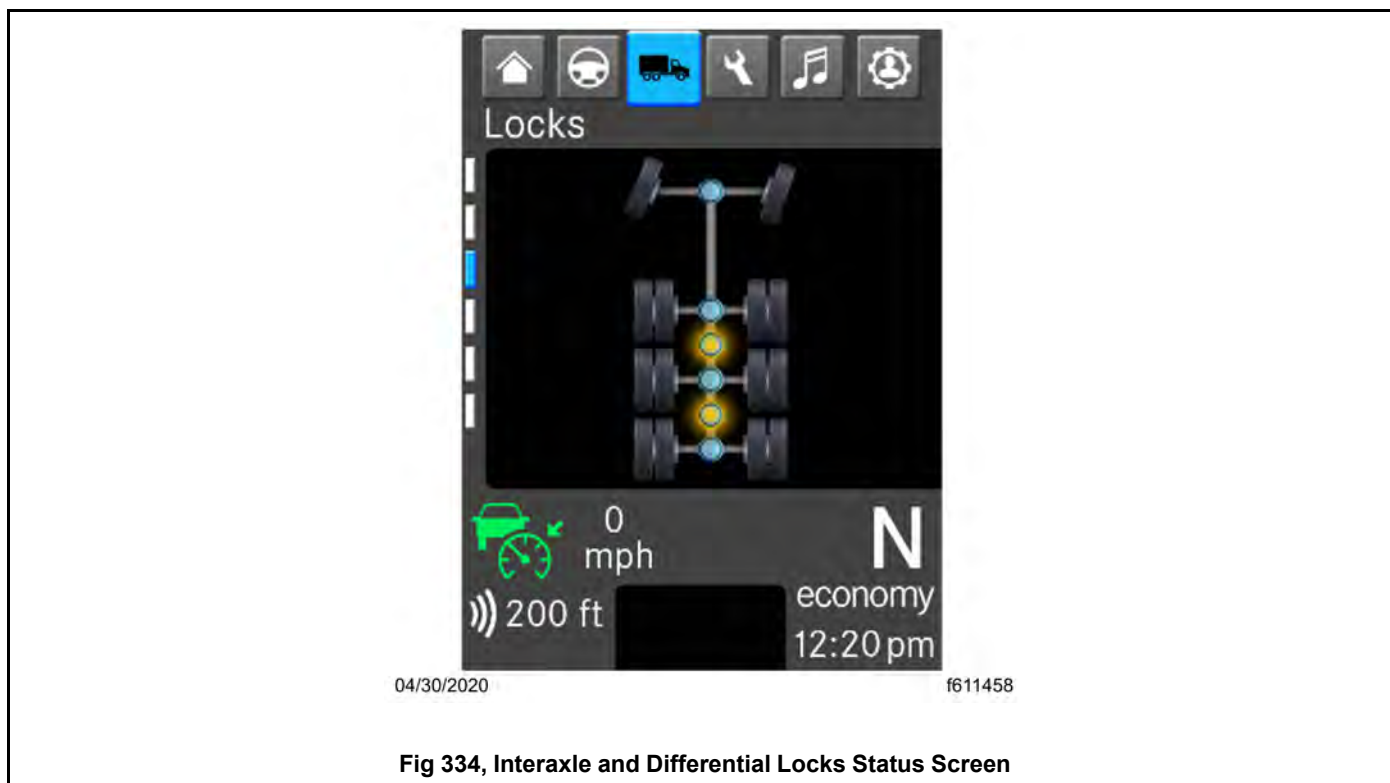
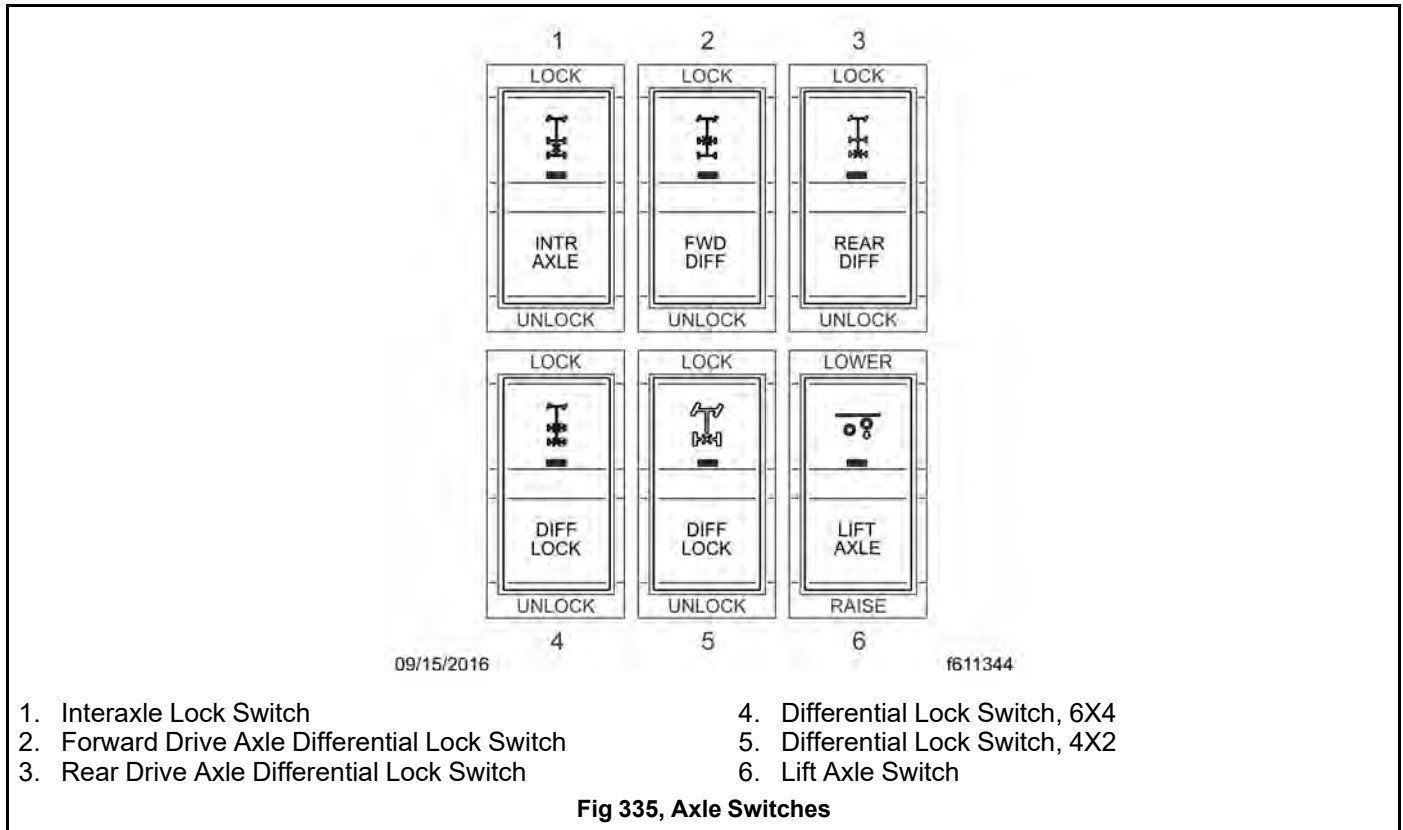

Fig 334, Interaxle and Differential Locks Status Screen

17.02 Interaxle Lock Switch

The interaxle lock switch, shown in Fig.285, [Axle Switches](#), allows the driver to lock the drive axles together.



17.03 Interaxle Lock Operation



NOTICE:

The interaxle lock should not be engaged on a vehicle with obviously spinning wheels. Engagement at high speed or power can damage the axle(s).

NOTE: If the interaxle lock is engaged when the engine is turned off, the interaxle lock will disengage.

1. With the engine running, press the upper half of the interaxle lock switch to engage the interaxle lock. Do not wait until traction is lost and the tires are spinning before engaging the interaxle lock.
2. If the vehicle is moving, briefly let up on the accelerator until the interaxle lock engages. An indicator light on the interaxle lock switch illuminates when the lock is engaged. Depending on the vehicle configuration, a buzzer may also sound.



NOTICE:

Do not operate the vehicle continuously with the interaxle locked during extended good road conditions. To do so could result in damage to the axle gearing and excessive driveline and tire wear.

3. Proceed over poor road conditions with caution.

4. Press the lower half of the interaxle lock switch to disengage the interaxle lock after leaving poor road conditions.
5. If the vehicle is moving, briefly let up on the accelerator to allow the interaxle lock to disengage, then resume driving at normal speed. Once the interaxle lock disengages, the indicator light will go off.

18.01 Fifth Wheel Lubrication	334
18.02 Fifth Wheel Coupling	335
18.02.01 General Information	335
18.02.02 Trailer Auxiliary Switch	335
18.02.03 Fontaine Fifth Wheel Coupling	335
18.02.04 Holland Fifth Wheels Coupling	340
18.02.05 Jost Fifth Wheel Coupling	346
18.03 Fifth Wheel Uncoupling	351
18.03.01 Manual Uncoupling	351
18.03.02 Air-Actuated Uncoupling	353
18.03.03 Preparing the Trailer for Uncoupling	354
18.03.04 Air-Activated Kingpin Unlock	355
18.04 Fifth Wheel Slide	356
18.04.01 General Information	356
18.04.02 Fifth Wheel Slide Control Switch.....	356
18.04.03 Air Slide Operation	357
18.05 Trailer Couplings	359
18.05.01 Holland Trailer Couplings.....	359
18.05.02 Holland Coupling Trailer Hookup	360
18.05.03 Holland Coupling Trailer Release	361
18.05.04 Premier Air Pintle Hitch Trailer Hookup	362
18.05.05 Premier Air Pintle Hitch Trailer Release	362

18. Fifth Wheels and Trailer Couplings

18.01 Fifth Wheel Lubrication



WARNING:

A standard fifth wheel plate must be kept lubricated to prevent binding between the tractor and trailer. A binding fifth wheel could cause erratic steering and loss of vehicle control, possibly resulting in personal injury or death.

The standard fifth wheel plate must be kept well lubricated with chassis grease to prevent friction and binding between the tractor fifth wheel plate and the trailer.

For lubrication instructions, see **Group 31** of the *M2 Plus Maintenance Manual*.

For a low-lube fifth wheel plate, inspect the condition of the low-lube pads. There should be no damaged or missing pieces. Slight puckering at the outside edges is normal.

For no-lube fifth wheel plates, inspect the condition of the no-lube pads. If any of the following conditions are present, replace the lube plates.

- Plates severely chipped, cracked, gouged, or bent.
- More than 20% of the lube plate coating missing from one or both plates due to normal wear.
- A straight edge laid across the lube plate contacts parts of the surrounding fifth wheel as shown in Fig. 286, [No-Lube Plate Wear Inspection](#).

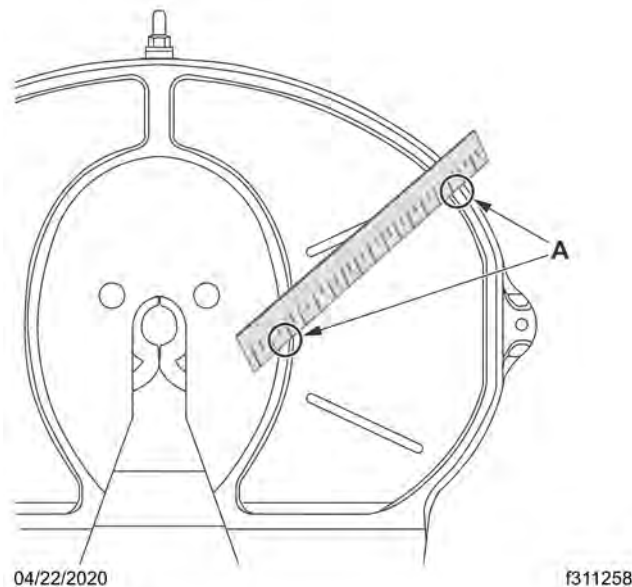

- A. Contact with the surrounding fifth-wheel when placing a straight edge across the lube plate indicates too much wear.

Fig 336, No-Lube Plate Wear Inspection

18.02 Fifth Wheel Coupling

18.02.01 General Information

**WARNING:**

Do not use any fifth wheel that fails to operate properly. Doing so may cause loss of vehicle control, possibly resulting in severe personal injury or death.

Fifth wheel coupling is activated with the lock control handle located on either the right or left side of the fifth wheel. Coupling has successfully occurred when the kingpin is in the fifth wheel jaws and the control handle has moved to the locked position.

Due to the number of options available, your vehicle may be equipped with a fifth wheel not described in this manual. In this situation, please reference the vendor literature on the fifth wheel installed.

**NOTICE:**

Some fifth wheels may be mounted on sliding rails. Before attempting to couple a trailer to a sliding fifth wheel, the slide feature must be locked to prevent the top plate from sliding rapidly forward or rearward, causing damage to the fifth wheel or kingpin.

18.02.02 Trailer Auxiliary Switch

The trailer auxiliary switch energizes an optional circuit that allows the trailer electrical system to draw power.

Press the top of the switch to activate the trailer auxiliary function. Press the bottom of the switch to turn trailer auxiliary function off. See 287, [Trailer Auxiliary Switch](#).



Fig 337, Trailer Auxiliary Switch

18.02.03 Fontaine Fifth Wheel Coupling

1. Chock the front and rear of the trailer tires to prevent the trailer from moving.
2. If equipped with a **standard fifth wheel**, check the surface of the fifth wheel for a liberal coating of grease.
If equipped with a **no- or low-lube fifth wheel**, inspect the conditions of the pads.
3. Ensure the fifth wheel jaws are fully open and the lock control handle is fully extended as shown in Fig. 288, [Fontaine Fifth Wheel Lock Handle Positions](#).

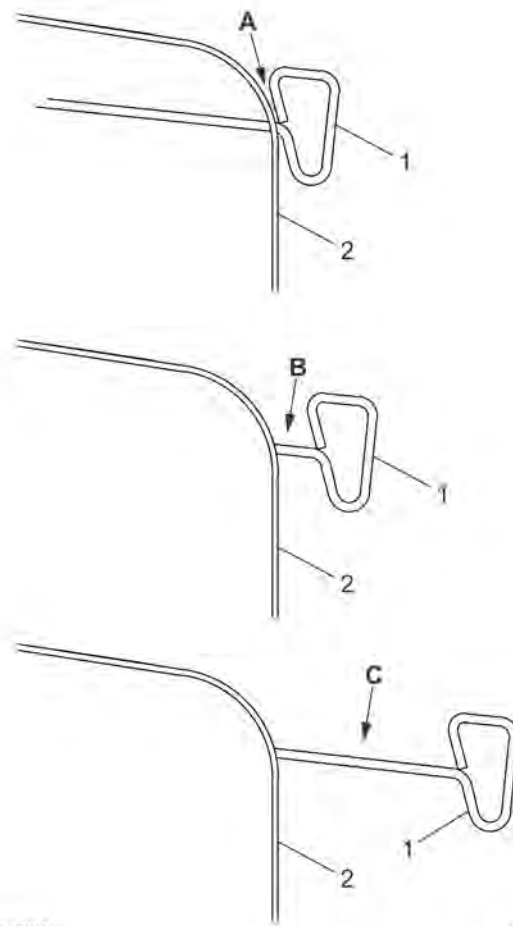

11/18/2021

f311376

- A. The base of the pull handle within 1 inch of the fifth wheel indicates the fifth wheel jaws are locked.
 B. A gap of more than 1 inch between the pull handle and fifth wheel indicates the fifth wheel jaws are partially open.

- C. A fully extended pull handle indicates the fifth wheel jaws are open.
 1. Pull Handle
 2. Fifth Wheel

Fig 338, Fontaine Fifth Wheel Lock Handle Positions

4. If equipped with a **standard fifth wheel** , inspect the trailer kingpin plate to verify it is large enough to completely cover the fifth wheel and is properly greased.
 If equipped with a **no- or low-lube fifth wheel** , ensure the leading edge of the trailer skid plate is free of sharp edges.
5. Make sure the fifth wheel top plate is tilted so the ramps are as low as possible.
6. Position the tractor so the kingpin is in a position to enter the throat of the fifth wheel as shown in Fig. 289, [Positioning the Tractor](#).

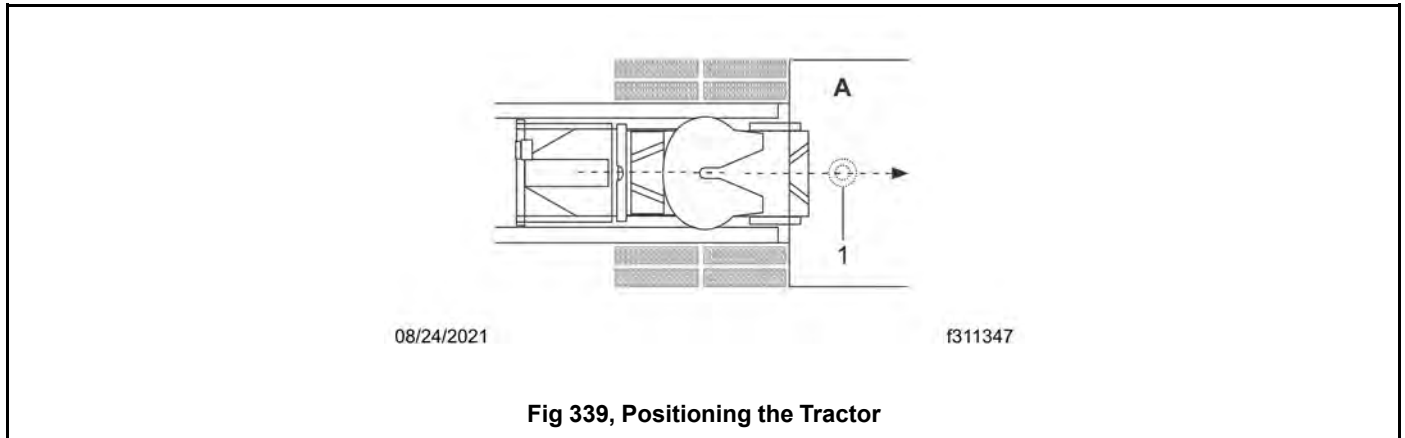
**WARNING:**

When coupling, always inflate the tractor suspension air bags prior to coupling.

Inflating the tractor suspension air bags while positioned underneath the trailer may result in damage to and incorrect coupling of the fifth wheel, possibly resulting in serious personal injury or death.

**NOTICE:**

Attempting to couple at the wrong height may cause improper coupling, which could result in damage to the fifth wheel or kingpin.

7. Adjust the trailer height if required.

For a **standard fifth wheel**, the trailer should contact the fifth wheel at the top of the approach ramps as shown in Fig.290, [Trailer Connection Point, Standard Fifth Wheel](#).

For a **no- or low-lube fifth wheel**, the fifth wheel must slide freely under the trailer; the trailer should contact the fifth wheel at the pivot point shown in Fig.291, [Trailer Connection Point for No- and Low-Lube Fifth Wheels](#).

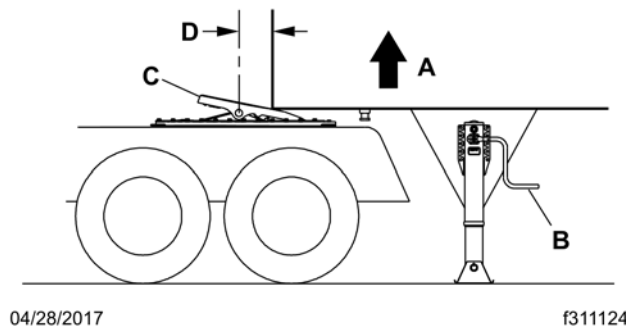

- A. The fifth wheel must lift the trailer.
 B. Adjust the trailer height if necessary.
 C. Tilt the ramps down.
 D. Trailer should contact fifth wheel 4-6 inches behind pivot point.

Fig 340, Trailer Connection Point, Standard Fifth Wheel

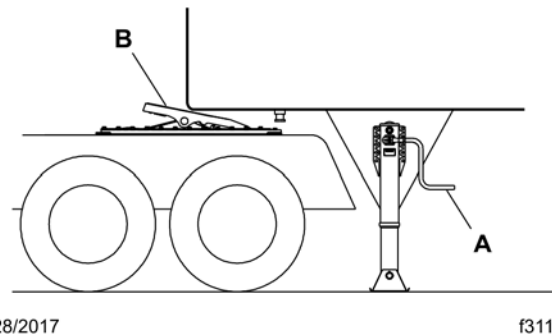

- A. Adjust trailer height as needed.
 B. Verify pivot point allows fifth wheel to slide under trailer.

Fig 341, Trailer Connection Point for No- and Low-Lube Fifth Wheels

8. With the fifth wheel opening aligned with the trailer kingpin, back the tractor slowly toward the trailer. To prevent the trailer from slamming into the kingpin, after sliding under the trailer, **stop** . Then resume backing up slowly until the fifth wheel locks.
9. Apply the tractor parking brakes.
10. Perform a coupling inspection.
 - 10.a Verify there is no gap between the bottom of the trailer and the fifth wheel as shown in Fig. 292, [Coupling Inspection View](#).
 - 10.b Make sure the jaw and wedge of the fifth wheel are locked in place behind the kingpin as shown in Fig. 292, [Coupling Inspection View](#).

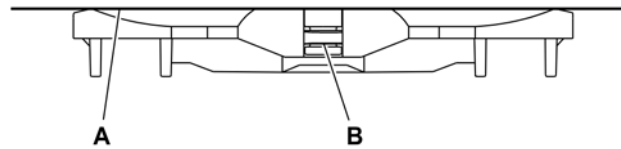

04/28/2017

f311126

A. Check that there is no gap between the trailer and fifth wheel.

B. Verify the kingpin is locked in the fifth wheel jaws.

Fig 342, Coupling Inspection View

- 10.c Check that the lock control handle is fully retracted as shown in Fig. 288, [Fontaine Fifth Wheel Lock Handle Positions](#); the gap between the back of the pull handle and the skirt of the fifth wheel should be *less than* one inch as shown in Fig. 293, [Fontaine Fifth Wheel Handle Retracted](#).

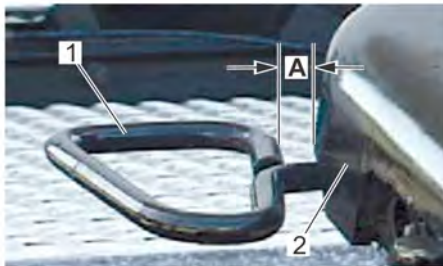

08/23/2021

f311363

A. Make sure there is less than a one inch gap between the back of the pull hand and the fifth wheel skirt.

1. Pull Handle
2. Skirt of Fifth Wheel

Fig 343, Fontaine Fifth Wheel Handle Retracted



WARNING:

Incorrect fifth wheel locking could cause the trailer to disconnect, possibly resulting in serious personal injury or death.

11. Release the tractor parking brakes.

Test for kingpin lockup by slowly inching the tractor forward, pulling on the trailer against the chocks.

12. After lockup is completed and verified, connect the tractor-to-trailer air system lines and the electrical cable to the trailer. Take care to prevent dirt or foreign material from entering the air system lines.

**NOTICE:**

Always make sure the connection hanger keeps the trailer air hoses and electrical cables positioned so that they do not rub on anything. Rubbing may wear through hoses or cables, resulting in air leaks, or exposed or broken wires, potentially affecting trailer brake or electrical systems.

13. Charge the air brake system with air, checking that the air connections do not leak.
14. Fully retract the landing gear legs and secure the crank handle.
15. Remove the chocks.

18.02.04 Holland Fifth Wheels Coupling

1. Chock the front and rear of the trailer tires to prevent the trailer from moving.
2. If equipped with a **standard fifth wheel**, check the surface of the fifth wheel for a liberal coating of grease.

If equipped with a **no- or low-lube fifth wheel plate** ensure there are no sharp edges, nuts, bolts, gouges, or large holes along the leading edge of the trailer or the path of the fifth wheel, as shown in Fig. 294, [Path of a Fifth Wheel](#), and that any upper coupler residual grease is free of coarse grit.

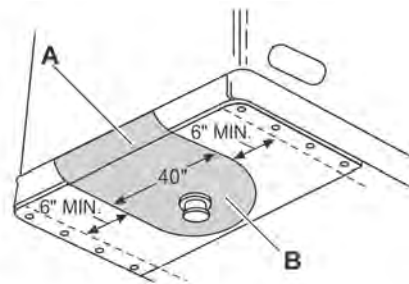

A. Keep the direct path of fifth wheel and six inches to either side free of large holes and gouges.

B. Keep bolts and nuts clear of the bolster plate.

Fig 344, Path of a Fifth Wheel

3. Ensure the fifth wheel jaw is fully open and the release handle is in the unlocked position.
 - 3.a To unlock a **Holland FW35/31** fifth wheel, pull out the release handle as shown in Fig. 295, [FW35 Holland Locks Open and Closed](#).

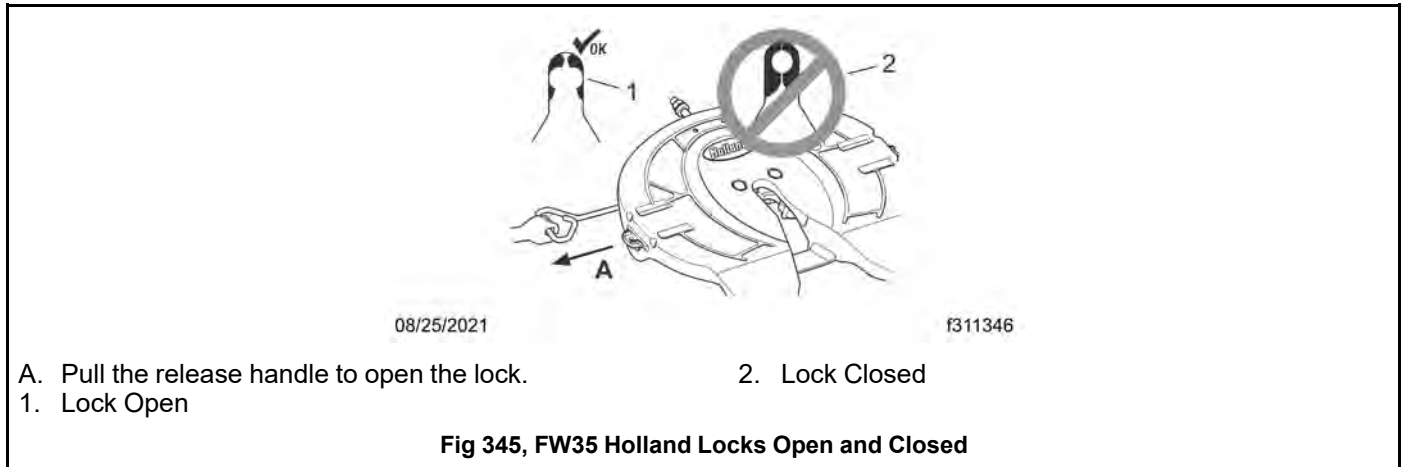

3.b To unlock a **Holland FWAL**:

- Slide the release handle forward to move the front notch on the locking plate clear of the bracket.
- Pull the release handle completely out.
- Slide the release handle forward again to hook the rear notch on the locking plate onto the bracket as shown in Fig.296,[Unlocking a Holland FWAL](#).

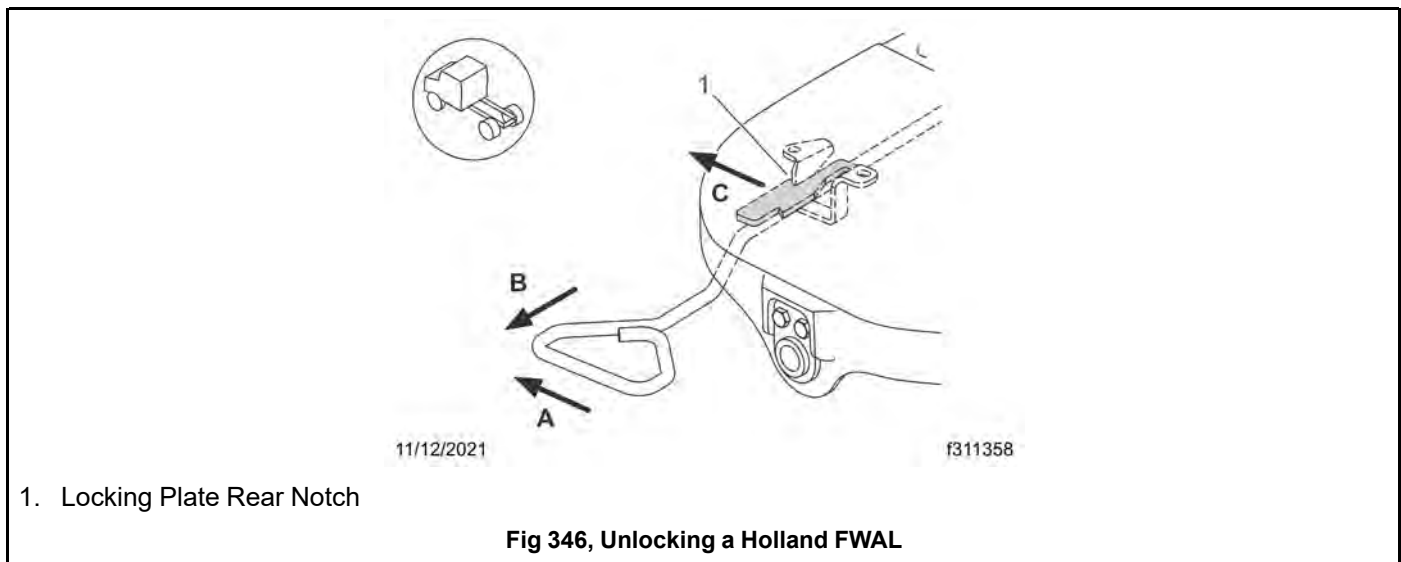

4. Make sure the fifth wheel top plate is tilted rearwards with the ramps down and resting on the tilt stops.
5. Position the tractor so that the center of the fifth wheel is in line with the trailer kingpin as shown in Fig. 302,[Positioning the Tractor](#) The kingpin should be in a position to enter the throat of the locking mechanism.

**NOTICE:**

Attempting to couple at the wrong height may cause improper coupling, which could result in damage to the fifth wheel or kingpin.

6. Adjust the trailer height if required.

For a **standard fifth wheel plate**, the trailer should contact the fifth wheel approximately 4 to 8 inches (10 to 20 cm) behind the fifth wheel pivot as shown in Fig.303, [Trailer Connection Point, Standard Fifth Wheel](#).

For a **no- or low-lube fifth wheel plate**, the fifth wheel must slide freely under the trailer; the trailer should contact the fifth wheel at the pivot point shown in Fig. 304, [Trailer Connection Point for No- and Low-Lube Fifth Wheels](#).

7. With the fifth wheel lock opening aligned with the trailer kingpin, back the tractor slowly toward the trailer. After sliding under the trailer, **stop** to prevent from hitting the kingpin, then resume backing up slowly until the fifth wheel locks.

On a standard fifth wheel, the fifth wheel must lift the trailer.

On a no- or low-lube fifth wheel, do **not** lift the trailer. Lifting the trailer with a no- or low-lube fifth wheel may damage the fifth wheel plate.

8. Apply the tractor parking brakes.

9. Perform a coupling inspection.

- 9.a Verifying a **Holland FW35/31 fifth wheel is locked**:

- Verify that there is no gap between the bottom of the trailer and the fifth wheel as shown in Fig. 297, [No Gap Between Fifth Wheel and Trailer](#).

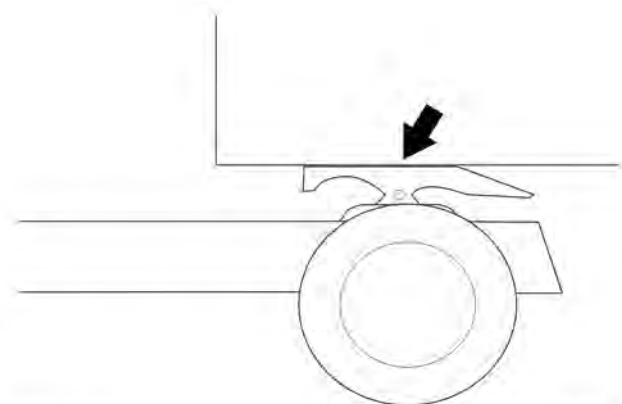

11/12/2021

f311402

Fig 347, No Gap Between Fifth Wheel and Trailer

- Verify that the kingpin is securely locked as shown in Fig. 298, [Kingpin Locked in Holland FW35/31 Fifth Wheel Jaws](#).
-

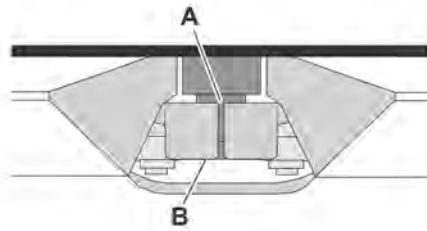

08/24/2021

f311351

A. Verify there is a 1/4 inch (6.35 mm) or less gap.

B. Verify that the locks are completely closed around the kingpin.

Fig 348, Kingpin Locked in Holland FW35/31 Fifth Wheel Jaws

- Verify that the nut and washer are snug against the fifth wheel as shown in Fig. 299, [Nut and Washer Snug Against Locked Holland FW35/31](#).
-

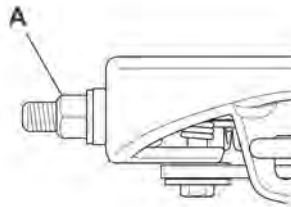

08/24/2021

f311350

A. Verify the nut and washer are snug against the fifth wheel

Fig 349, Nut and Washer Snug Against Locked Holland FW35/31

9.b Verifying a **Holland FWAL is locked:**

- Verify that there is no gap between the bottom of the trailer and the fifth wheel as shown in Fig. 297, [No Gap Between Fifth Wheel and Trailer](#).
- Verify that the kingpin is securely locked as shown in Fig. 300, [Holland FW17 or FWAL Lock Closed Around Kingpin](#).
-

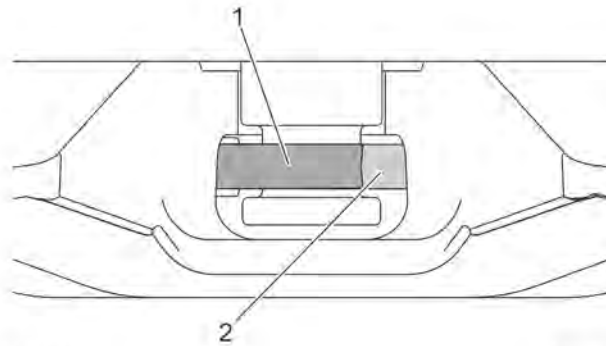

11/12/2021

f311403

1. Lock Completely Closed Around Kingpin

2. Lock Retainer Securing Lock

Fig 350, Holland FW17 or FWAL Lock Closed Around Kingpin

- Verify that the handle is fully retracted as shown in Fig.301, [Holland FWAL Handle Fully Retracted](#).
-

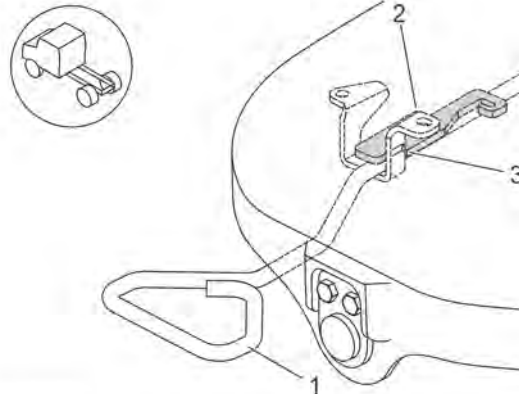

11/15/2021

f311401

1. Handle

2. Locking Plate Rear Notch (behind top of bracket)

3. Locking Plate Front Notch (behind arm of bracket)

Fig 351, Holland FWAL Handle Fully Retracted

10. Release the tractor parking brakes.

Test for kingpin lockup by slowly inching the tractor forward, pulling the trailer against the chocks.

11. After lockup is completed, connect the tractor-to-trailer air system lines and the electrical cable to the trailer. Take care to prevent dirt or foreign material from entering the air system lines.

**NOTICE:**

Always make sure the connection hanger keeps the trailer air hoses and electrical cables positioned so that they do not rub on anything. Rubbing may wear through hoses or cables, resulting in air leaks, or exposed or broken wires, potentially affecting trailer brake or electrical systems.

12. Charge the air brake system with air, checking that the air connections do not leak.

**WARNING:**

Incorrect fifth wheel lock adjustment could cause the trailer to disconnect, possibly resulting in serious personal injury or death.

13. With the trailer wheels chocked and the brakes set, check for clearance between the kingpin and the fifth wheel jaws by moving the tractor forward and backward against the locked kingpin. If slack is present, uncouple the trailer and have the fifth wheel inspected and adjusted by a certified technician.

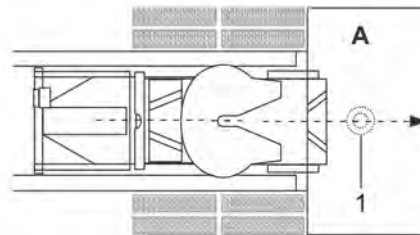

08/24/2021

f311347

Fig 352, Positioning the Tractor

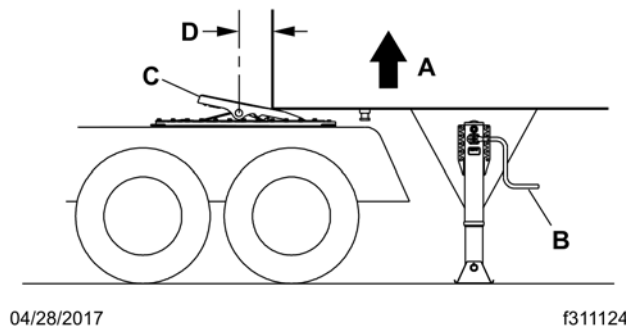

04/28/2017

f311124

- A. The fifth wheel must lift the trailer.
- B. Adjust the trailer height if necessary.
- C. Tilt the ramps down.
- D. Trailer should contact fifth wheel 4-6 inches behind pivot point.

Fig 353, Trailer Connection Point, Standard Fifth Wheel

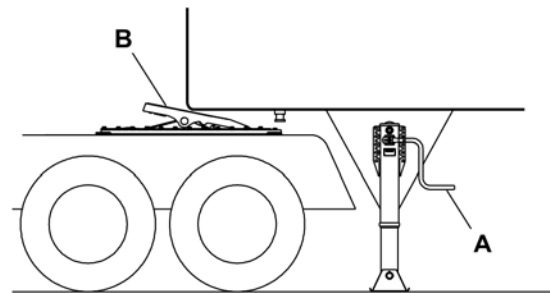

04/28/2017

f311125

- A. Adjust trailer height as needed.
- B. Verify pivot point allows fifth wheel to slide under trailer.

Fig 354, Trailer Connection Point for No- and Low-Lube Fifth Wheels

18.02.05 Jost Fifth Wheel Coupling

1. Chock the front and rear of the trailer tires to prevent the trailer from moving.
2. Tilt the fifth wheel ramps down.
3. Unlock the fifth wheel jaws.

Lift the release handle up into the wide slot and then pull the release handle out while moving it forward as shown in Fig.305, [Unlocking the Jost Fifth Wheel](#) Lock the handle into the open position on the notch provided.

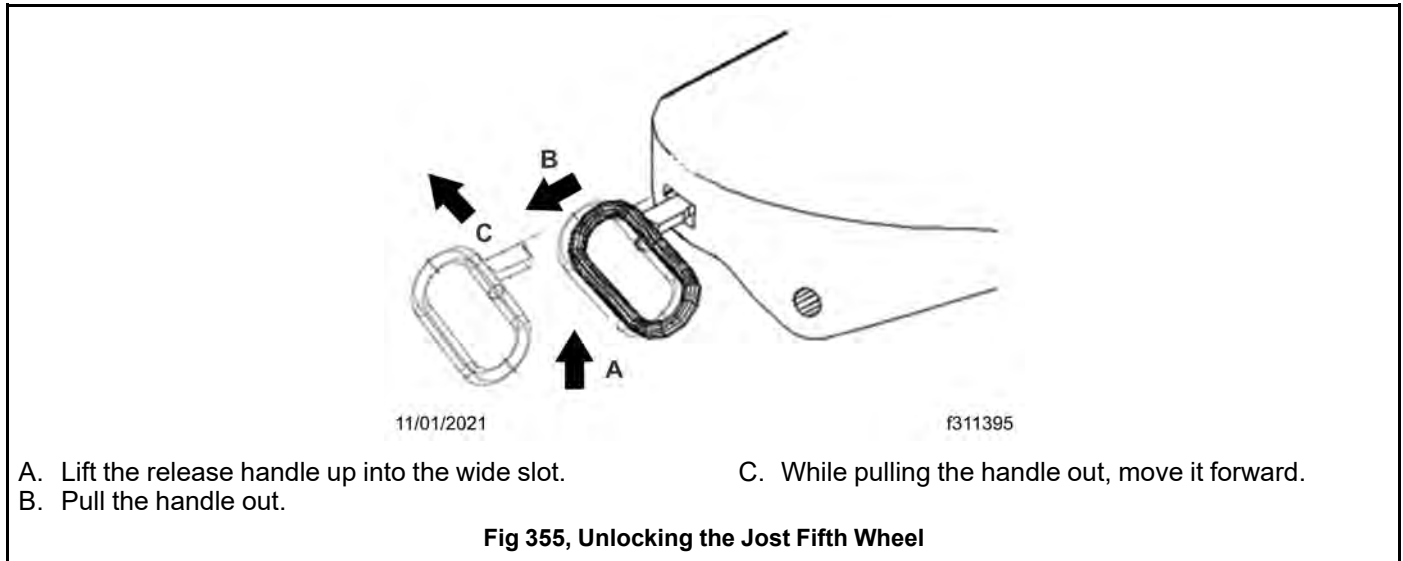

4. Back the vehicle close to the trailer, centering the kingpin on the fifth wheel throat as shown in Fig. 308, [Positioning the Tractor](#)

**NOTICE:**

Attempting to couple at the wrong height may cause improper coupling, which could result in damage to the fifth wheel or kingpin.

5. Adjust the trailer height (if required).

For a standard fifth wheel plate, the trailer should contact the fifth wheel the top of the approach ramps or approximately 4 to 6 inches (10 to 20 cm) behind the pivot point as shown in Fig. 309, [Trailer Connection Point, Standard Fifth Wheel](#).

For a low-lube fifth wheel plate, the trailer should contact the fifth wheel at the pivot point and the fifth wheel must slide freely under the trailer as shown in Fig. 310, [Trailer Connection Point for No- and Low-Lube Fifth Wheels](#)

6. Back the tractor slowly toward the trailer.

On a **standard fifth wheel**, the fifth wheel must lift the trailer.

On a **no- or low-lube fifth wheel**, do **not** lift the trailer. Lifting the trailer with a no- or low-lube fifth wheel may damage the fifth wheel plate.

After lifting or sliding under the trailer, **stop**. This is to prevent hitting the kingpin too hard. Then resume backing up slowly until the fifth wheel locks.



WARNING:

A visual inspection is required by law.

Some improper couplings can pass a pull test. Sound is not reliable.

Get out of the cab and look.

Incorrect coupling could cause the trailer to disconnect, possibly resulting in serious personal injury or death.

7. Apply the tractor parking brake, then perform a physical check for positive kingpin lockup.

Depending on the fifth wheel model, the handle should be fully retracted with the handle inside the narrow slot as shown in Fig.306, [Locked Jost Fifth Wheel](#) or the release handle should abut the casting as shown in Fig. 307, [Jost Release Handle Locked](#)

There should be no gap between the trailer and the fifth wheel.

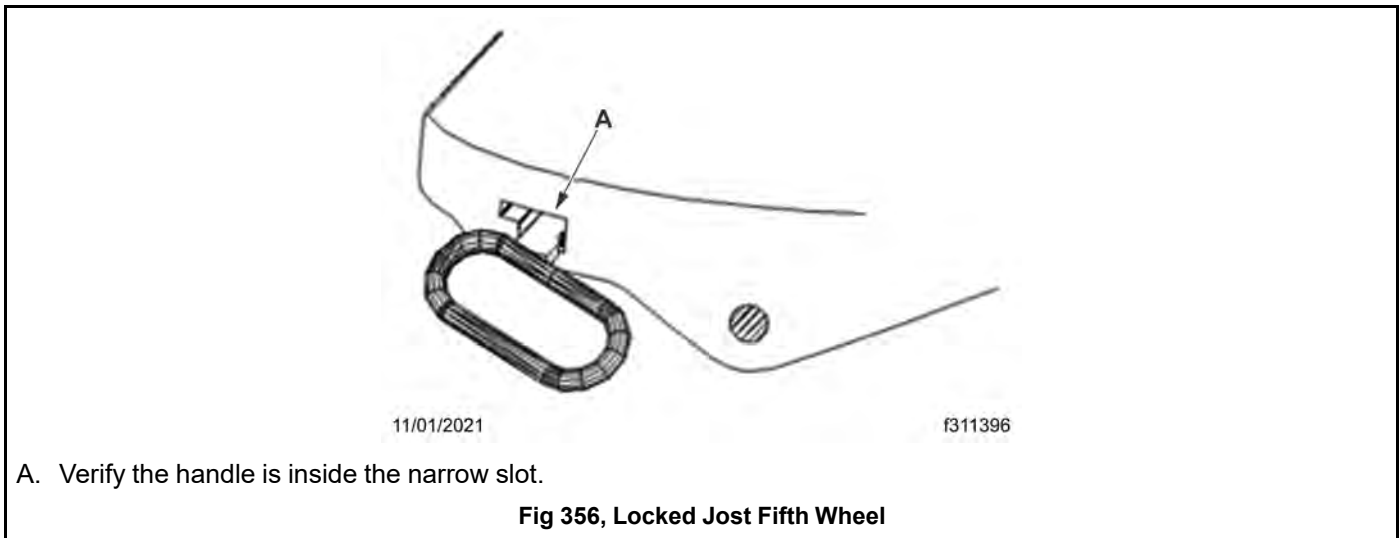

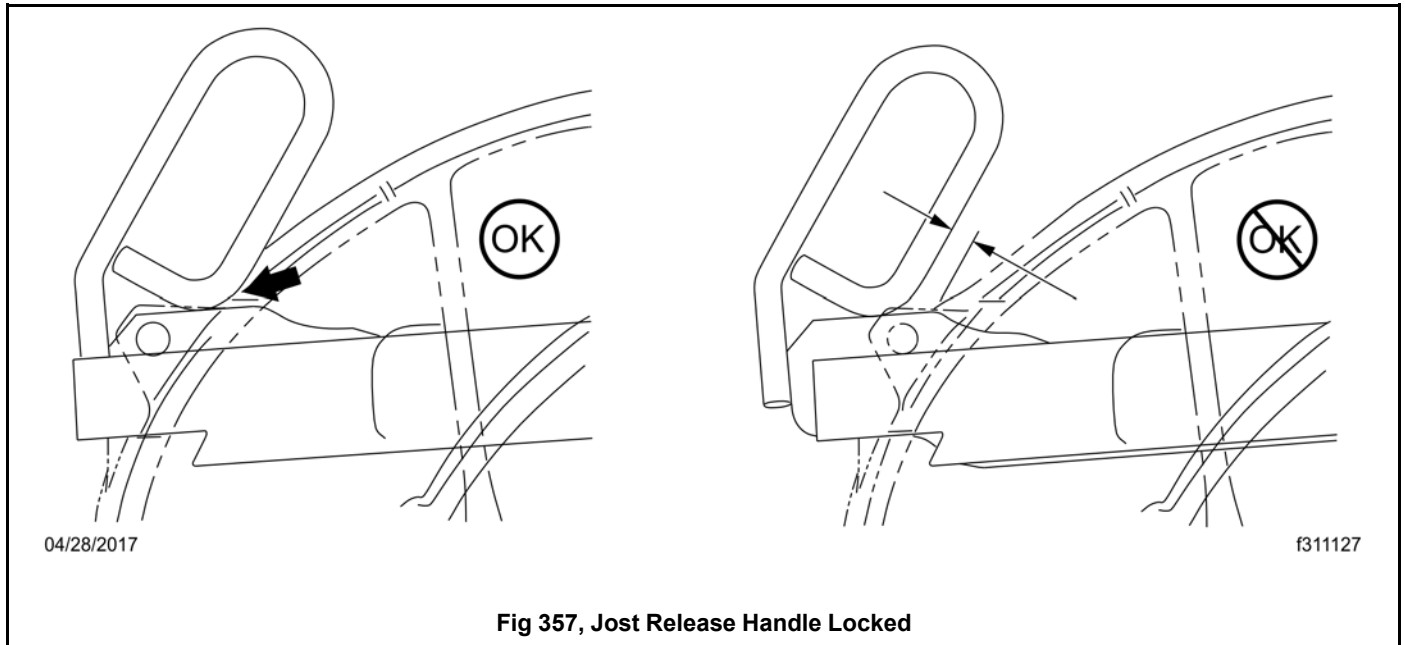

8. Release the tractor parking brakes and test for kingpin lockup by slowly moving the tractor forward, pulling the trailer against the chocks.
9. After lockup is verified, connect the tractor-to-trailer air system lines and the electrical cable to the trailer. Take care to prevent dirt or foreign material from entering the air system lines.

**NOTICE:**

Always make sure the connection hanger keeps the trailer air hoses and electrical cables positioned so that they do not rub on anything. Rubbing may wear through hoses or cables, resulting in air leaks, or exposed or broken wires, potentially affecting trailer brake or electrical systems.

10. Charge the air brake system with air, checking that the air connections do not leak.
11. Fully retract the landing gear legs and secure the crank handle.
12. Remove the chocks.

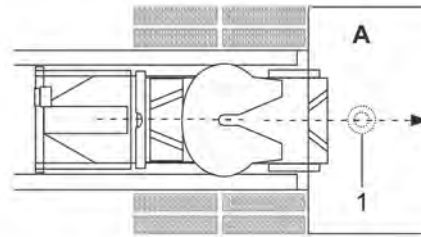

08/24/2021

f311347

Fig 358, Positioning the Tractor

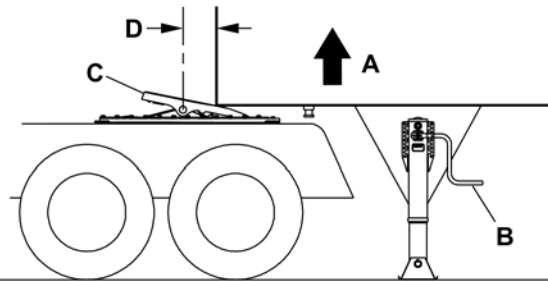

04/28/2017

f311124

- A. The fifth wheel must lift the trailer.
- B. Adjust the trailer height if necessary.
- C. Tilt the ramps down.

- D. Trailer should contact fifth wheel 4-6 inches behind pivot point.

Fig 359, Trailer Connection Point, Standard Fifth Wheel

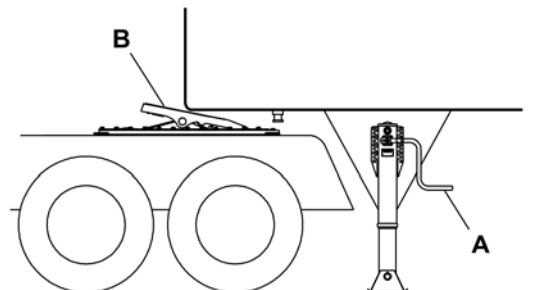

04/28/2017

f311125

- A. Adjust trailer height as needed.

- B. Verify pivot point allows fifth wheel to slide under trailer.

Fig 360, Trailer Connection Point for No- and Low-Lube Fifth Wheels

18.03 Fifth Wheel Uncoupling

18.03.01 Manual Uncoupling

1. Slowly back the tractor tightly against the trailer to relieve pressure on the fifth wheel lock.
2. Apply the tractor and trailer parking brakes.
3. Chock the trailer rear wheels.
4. Lower the trailer landing gear until the weight is removed from the fifth wheel.
5. Disconnect the tractor-to-trailer air system lines and electrical cable. Plug the air lines to prevent dirt or foreign material from entering the lines.
6. Verify that both the yellow parking-brake and red trailer-air-supply knobs are out, the tractor and trailer parking brakes are set, and that the trailer is prepared for uncoupling.
7. Release the kingpin locking mechanism following the instructions for each manufacturer below.
 - 7.a **Fontaine:** Lift the safety latch and pull the lock control handle to the unlocked position as shown in Fig. 312, [Fontaine Fifth Wheel Lock Handle Positions](#).
 - 7.b **Holland FW35/33:** Pull out the release handle as shown in Fig. 313, [FW35 Holland Locks Open and Closed](#).
 - 7.c **Holland FWAL:** Slide the handle forward to move the front notch on the locking plate clear of the bracket. Pull the handle completely out. Slide the handle forward again to hook the rear notch on the locking plate onto the bracket as shown in Fig. 314, [Unlocking a Holland FWAL](#).
 - 7.d **Jost:** Depending on the fifth wheel either:

Lift the release handle up into the wide slot and then pull the handle out while moving it forward as shown in Fig. 315, [Unlocking the Jost Fifth Wheel](#). Then lock the handle into the open position on the notch provided.

Or, in the event of a failure in an air release system, pull the handle directly out and hook it open on the notch as shown in Fig. 311, [Jost Release Handle Unlocked](#).

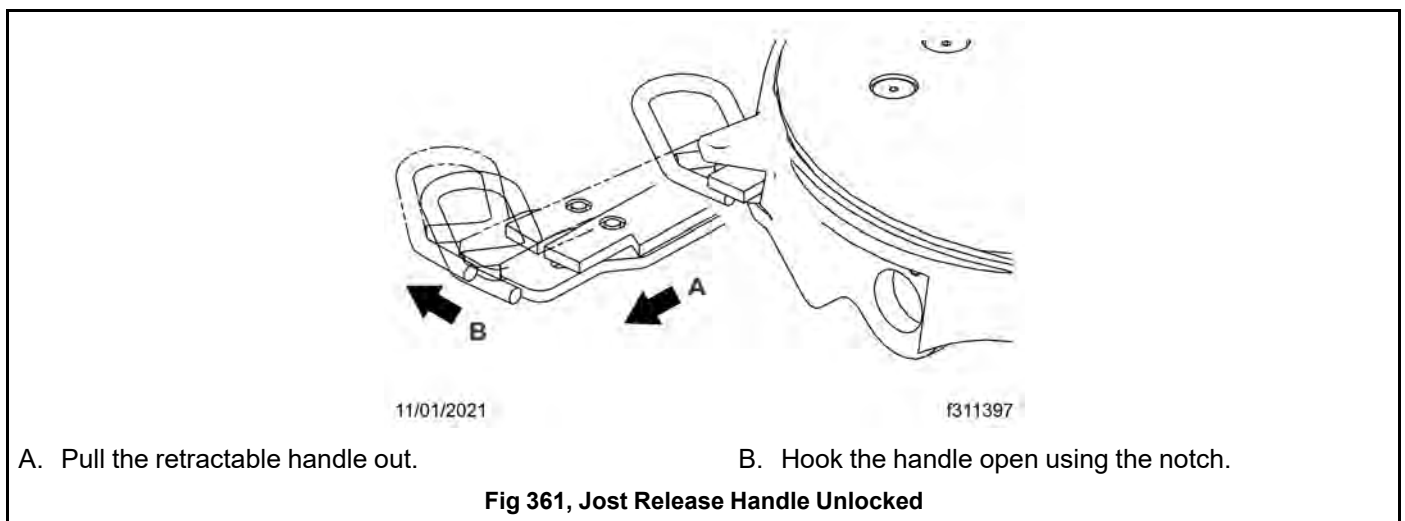

8. Release the tractor parking brake then drive forward slowly, allowing the trailer to slide down the fifth wheel and off the ramps.

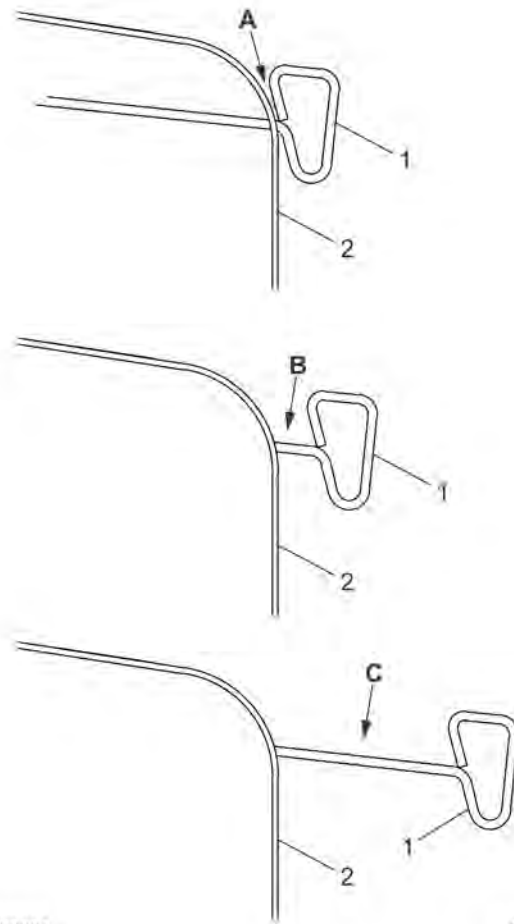

11/18/2021

f311376

- A. The base of the pull handle within 1 inch of the fifth wheel indicates the fifth wheel jaws are locked.
- B. A gap of more than 1 inch between the pull handle and fifth wheel indicates the fifth wheel jaws are partially open.

- C. A fully extended pull handle indicates the fifth wheel jaws are open.
- 1. Pull Handle
- 2. Fifth Wheel

Fig 362, Fontaine Fifth Wheel Lock Handle Positions

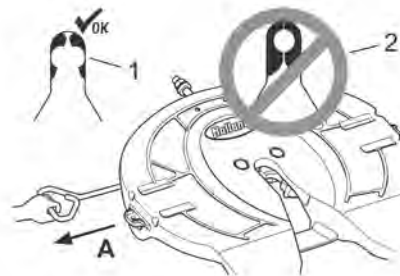

08/25/2021

f311346

- A. Pull the release handle to open the lock.
- 1. Lock Open

- 2. Lock Closed

Fig 363, FW35 Holland Locks Open and Closed

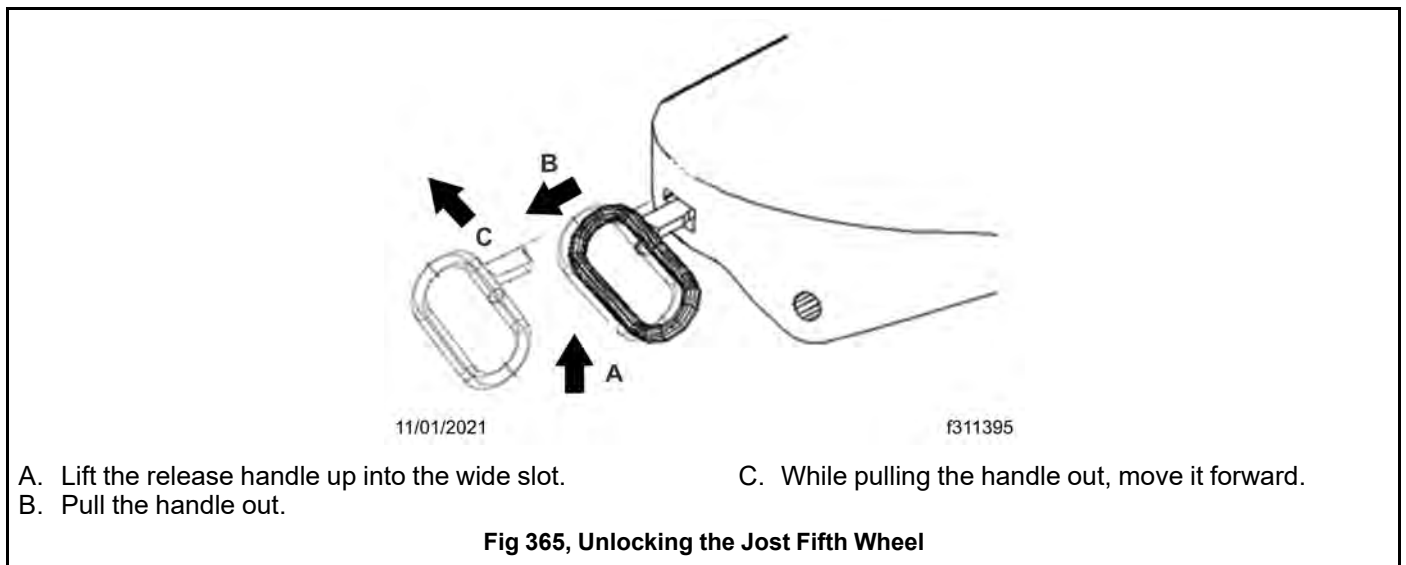
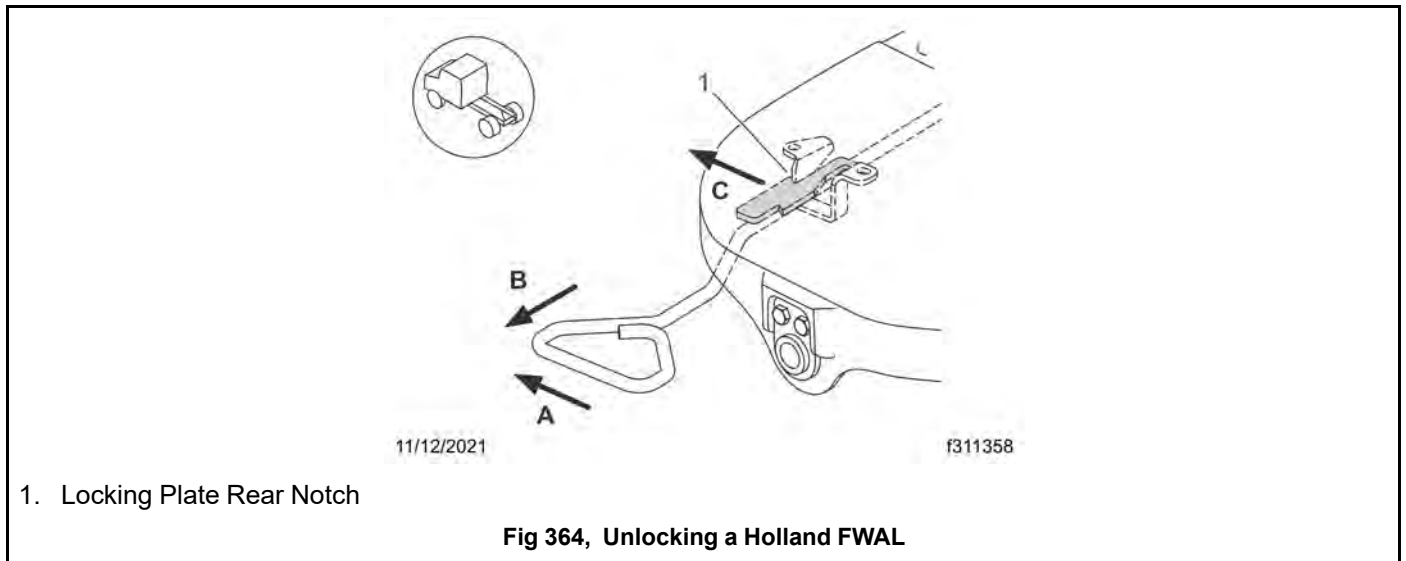

18.03.02 Air-Actuated Uncoupling

A dash-mounted kingpin release switch (if so equipped) may be used to uncouple the trailer. See Fig. 316, [Kingpin Release Switch](#).

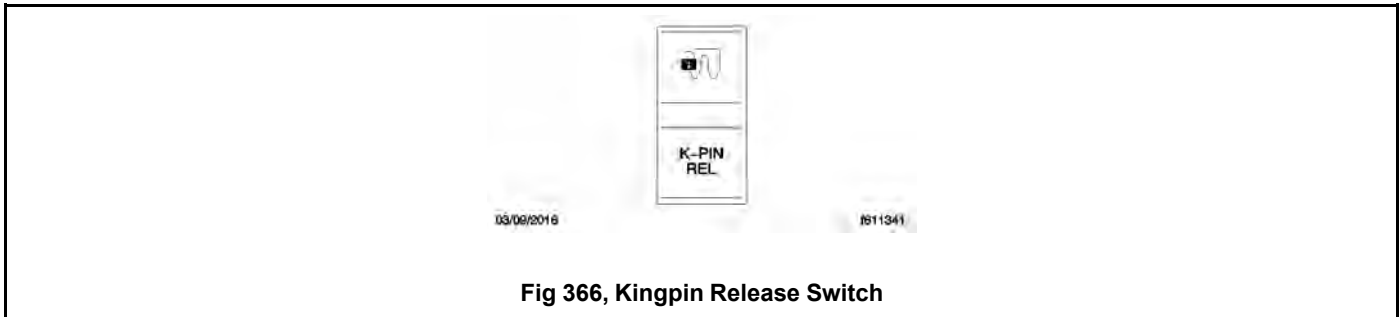

NOTE: In the event of an air system failure, air-actuated kingpins can be manually released following the instructions for manual uncoupling. If there is an issue, see Fig.317, [Kingpin Release Not Confirmed Popup, ICUC](#) should appear on the driver's display screen.



WARNING:

Once the kingpin release switch has been pushed, the kingpin lock is released. The vehicle **MUST NOT** be driven with the trailer until the trailer has been uncoupled and coupled again. Failure to do so may result in separation of the trailer from the tractor, possibly causing serious personal injury or death.

18.03.03 Preparing the Trailer for Uncoupling

Before using the air valve to unlock a fifth wheel kingpin, prepare the trailer as follows.

1. Slowly back the tractor tightly against the trailer to relieve pressure on the fifth wheel locks.
2. Apply the tractor and trailer parking brakes.
3. Chock the trailer rear wheels.
4. Lower the trailer landing gear until the weight is removed from the fifth wheel.
5. Disconnect the tractor-to-trailer air lines and electrical cable. Plug the air lines to prevent dirt or foreign material from entering the lines.

18.03.04 Air-Activated Kingpin Unlock

NOTE: The kingpin release will not activate if the vehicle is moving, the parking brake is not set, or if the switch is pushed for less than 3 seconds. Unless all of these conditions are met, the trailer will not be uncoupled.

If the kingpin release switch is pressed for less than 3 seconds, see Fig.

318, [Kingpin Release Not Activated Popup, ICUC](#) will appear on the driver display. Press the back arrow to dismiss the popup.



1. Verify that both the yellow parking-brake and red trailer-air supply knobs are out, the tractor and trailer parking brakes are set, and that the trailer is prepared for uncoupling.
2. Push and hold the kingpin release switch, shown in Fig.320, [Kingpin Release Switch](#), for a minimum of 3 seconds. The system will apply air for 20 to 30 seconds to ensure the kingpin unlocks. When the kingpin is unlocked, a notification is displayed as shown in Fig.319, [Kingpin Release Alert Screen, ICUC](#)
3. Release the tractor parking brake.
4. Drive out from under the trailer.

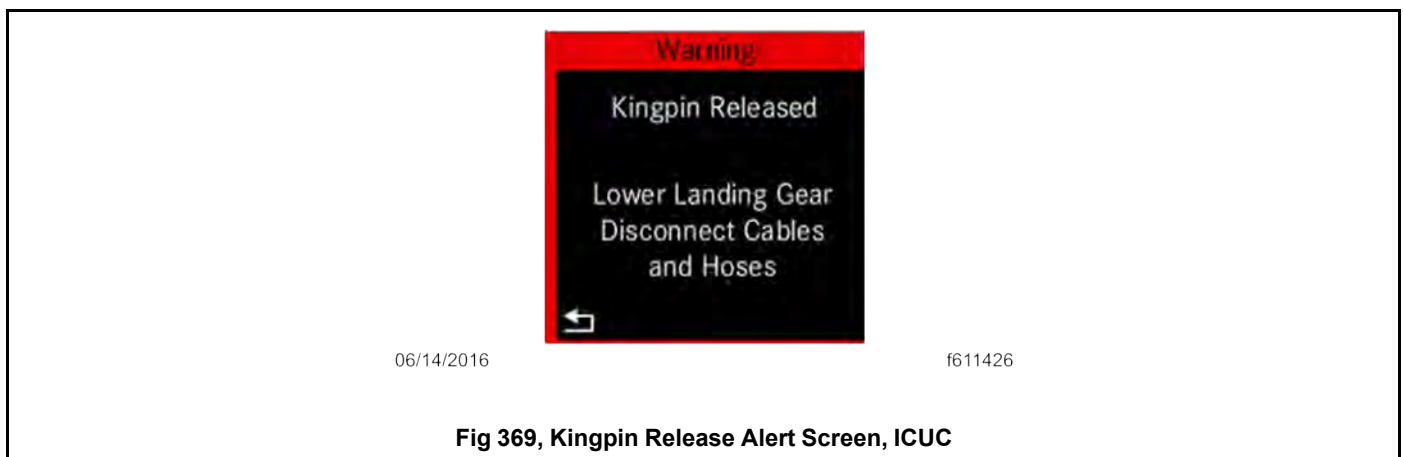

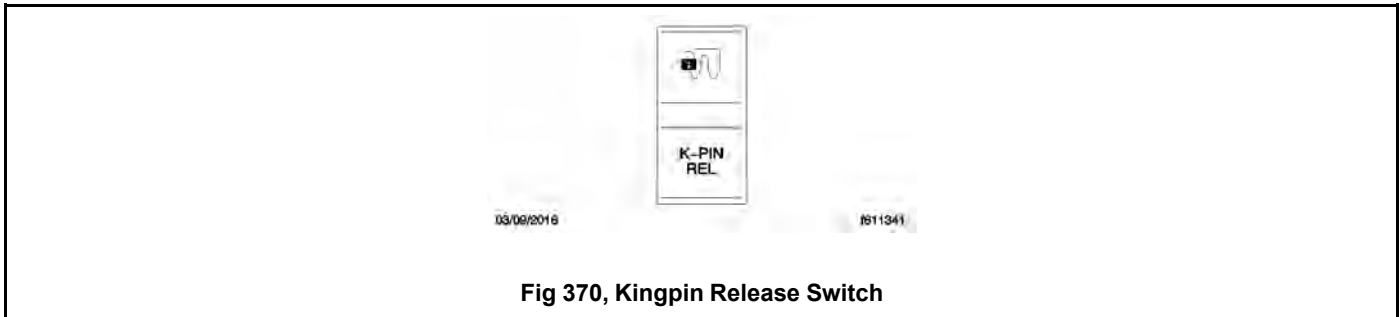

18.04 Fifth Wheel Slide

18.04.01 General Information

IMPORTANT: Adjust the fifth wheel slide correctly. Do not overload any tractor axle by incorrectly loading the trailer. Incorrect slide adjustment or improper axle loading could cause erratic steering and loss of vehicle control, possibly resulting in serious personal injury or death.

On sliding fifth wheel assemblies, the fifth-wheel plate is attached to rails that allow forward and rearward movement of the fifth wheel to optimally distribute the load across the axles. Slots are evenly spaced along the slide rails, and retractable wedges are positioned through the slots to hold the fifth wheel in the desired position.

The amount of load distribution on the front steering axle and rear drive axle(s) will have a direct effect on the steering control of the vehicle. Determine the front and rear axle weights by weighing the vehicle on scales designed for this purpose.

The maximum axle weight ratings are shown on the Federal Motor Vehicle Safety Standard (FMVSS) label or Canadian Motor Vehicle Safety Standard (CMVSS) label; see the 'Vehicle Identification' chapter for the location of these labels on your vehicle. The desired load on the axle is no less than 80 percent of the maximum axle weight rating, but in no instances should the axle load exceed the maximum axle weight rating given on the FMVSS or CMVSS label.

18.04.02 Fifth Wheel Slide Control Switch

**NOTICE:**

Do not activate the fifth wheel slide control valve while the vehicle is in motion. To do so could cause damage to the fifth wheel member, the kingpin, the cab or trailer, and ultimately to the drivetrain.

The fifth wheel air slide switch operates an air cylinder that locks and unlocks the slide. See Fig. 321, [Fifth Wheel Slide Control Switch](#).

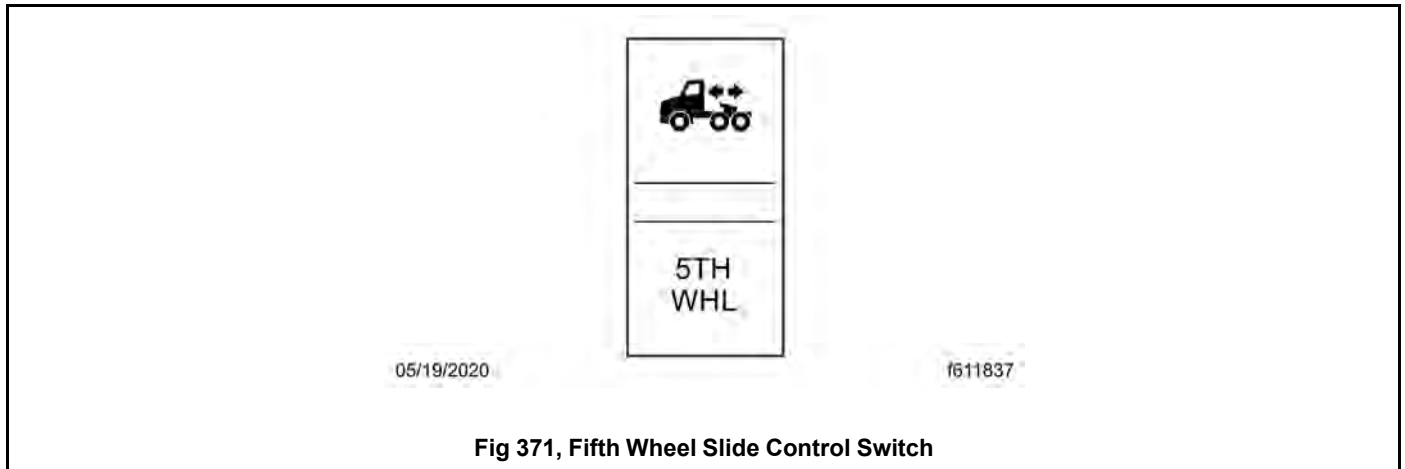

Moving the air slide control valve switch to the lock position deactivates the control valve and locks the fifth wheel to the baseplate. Moving the switch to the SLIDE position activates the control valve and unlocks the fifth wheel slide mechanism, allowing changes to the total length of the tractor-trailer and changes to axle loads to comply with varying jurisdictional laws.

18.04.03 Air Slide Operation

1. Set the air-slide switch to SLIDE.

Ensure the locking plungers have released.

For **Fontaine** fifth wheels, see Fig.322,[Locked Fontaine Air-Operated Sliding Fifth Wheel](#) and see Fig. 323,[Unlocked Fontaine Air-Operated Sliding Fifth Wheel](#) for depictions of the locked and unlocked states.

For **Holland** fifth wheels, locking plungers retract as shown in Fig. 324, [Holland Air-Operated Sliding Fifth Wheel](#).

For **Jost** fifth wheels, the mechanism activates as shown in Fig.325, [Jost Sliding Fifth Wheel](#).

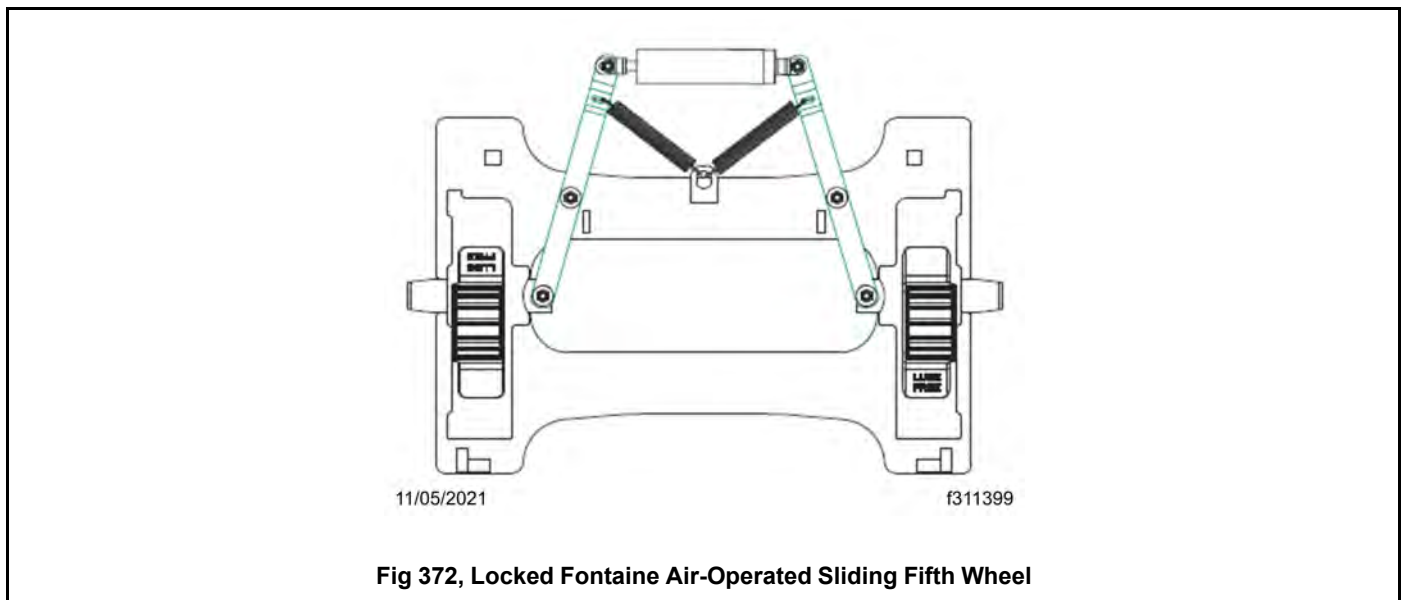

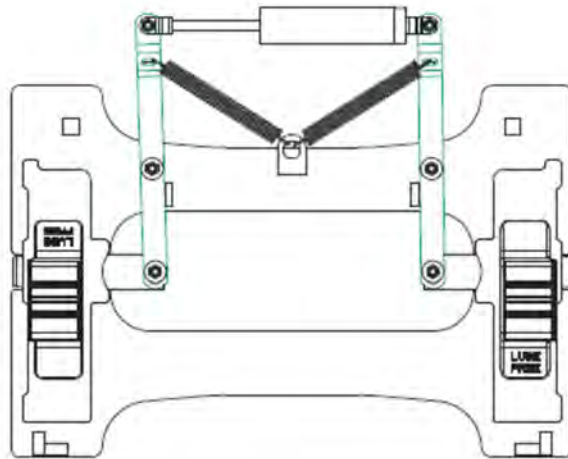

11/05/2021

f311400

Fig 373, Unlocked Fontaine Air-Operated Sliding Fifth Wheel

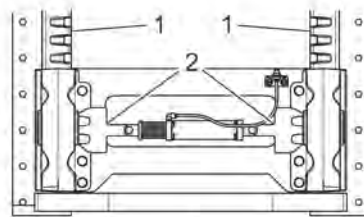

A

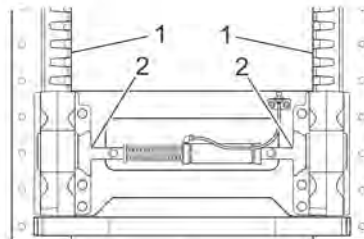

B

08/25/2021

f311364

- A. Unlocked with plungers retracted.
- B. Locked with plungers in rack.

- 1. Racks
- 2. Plungers

Fig 374, Holland Air-Operated Sliding Fifth Wheel

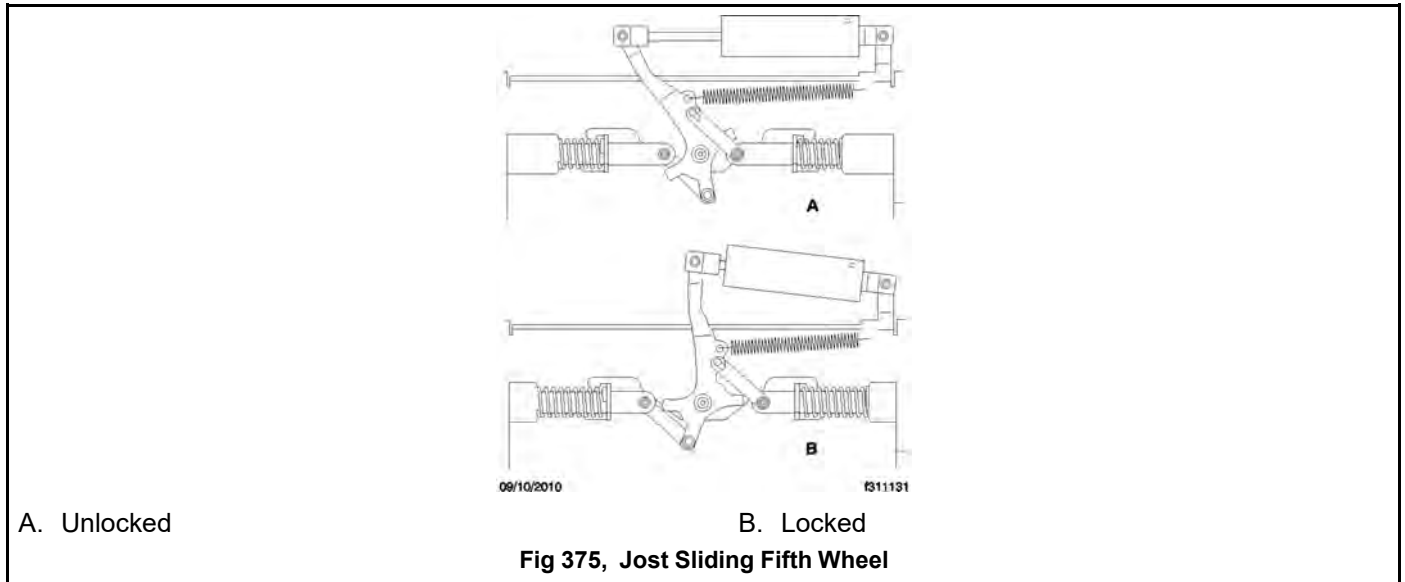

2. Lower the trailer landing gear just enough to remove the weight from the tractor.
3. Pull the red trailer-air-supply knob to set the trailer-parking brakes.
4. Slowly move the tractor forward or backward until the fifth wheel is in the desired location.

NOTE: Ensure the trailer landing gear does not come in contact with the tractor frame or other components, and that the front of the trailer will not come in contact with the rear of the cab or other components if they extend beyond the rear of the cab.

5. Apply the tractor parking brakes.



WARNING:

Check that the locking wedges have seated in the slots. Failure to achieve complete lockup may allow disengagement of the tractor from the trailer, possibly resulting in serious personal injury or death.

6. Set the air-slide switch to LOCK. Visually inspect the locking wedges or plungers to make sure that they are fully inserted in the slide rail slots. The fifth wheel may need to be moved slightly to enable the locking wedges to fully lock.

Further verify that the plungers have engaged by tugging the tractor forward while the trailer brakes are locked and the wheels are chocked.

18.05 Trailer Couplings

18.05.01 Holland Trailer Couplings

IMPORTANT: Refer to the Holland web site (www.safholland.us/us/en/) for additional information.

The Holland trailer coupling is designed for use with trailers having a maximum gross weight of 30,000 lb. (13,610 kg) for Holland PH-30RP41 and PH-30RP51. It is a rigid-type pintle hook, used only on tractor applications, and is fastened

to the rear closing crossmember of the vehicle. It is a non-air-adjusted coupling. See Fig. 326, [Holland Trailer Coupling with FastLatch](#) and see Fig. 327, [Holland Trailer Coupling with Lock Pin](#).

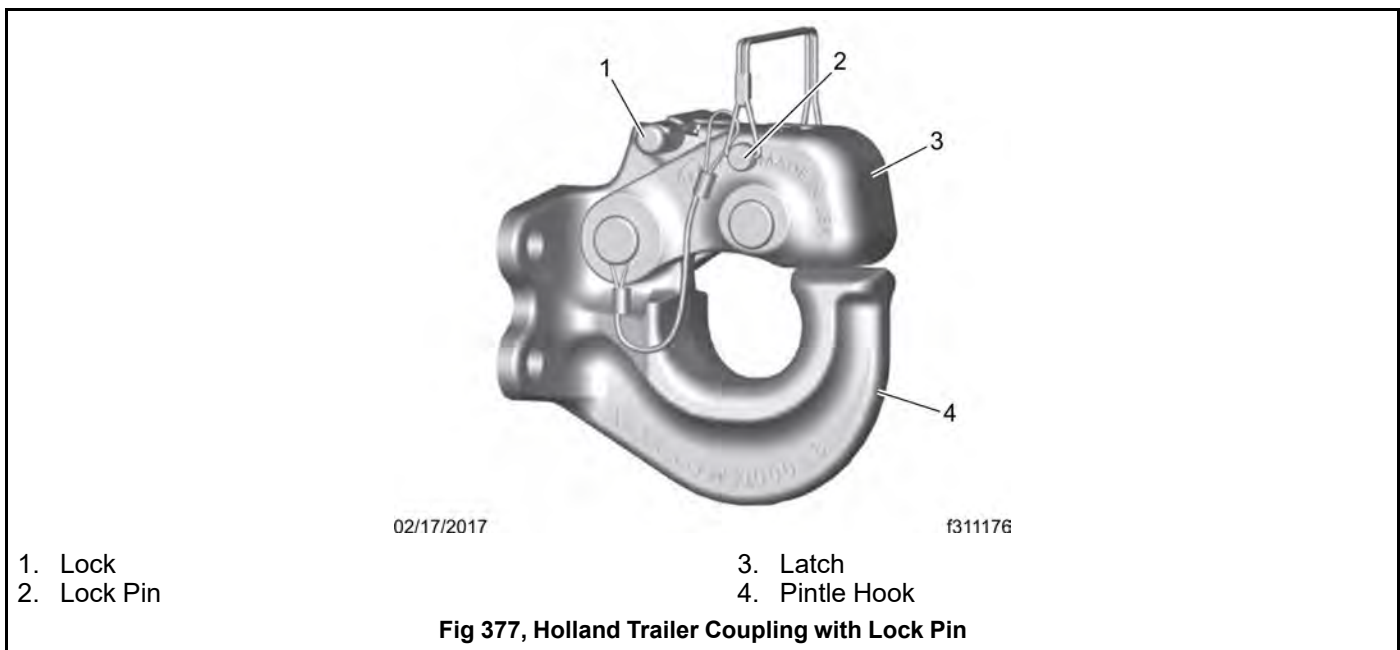
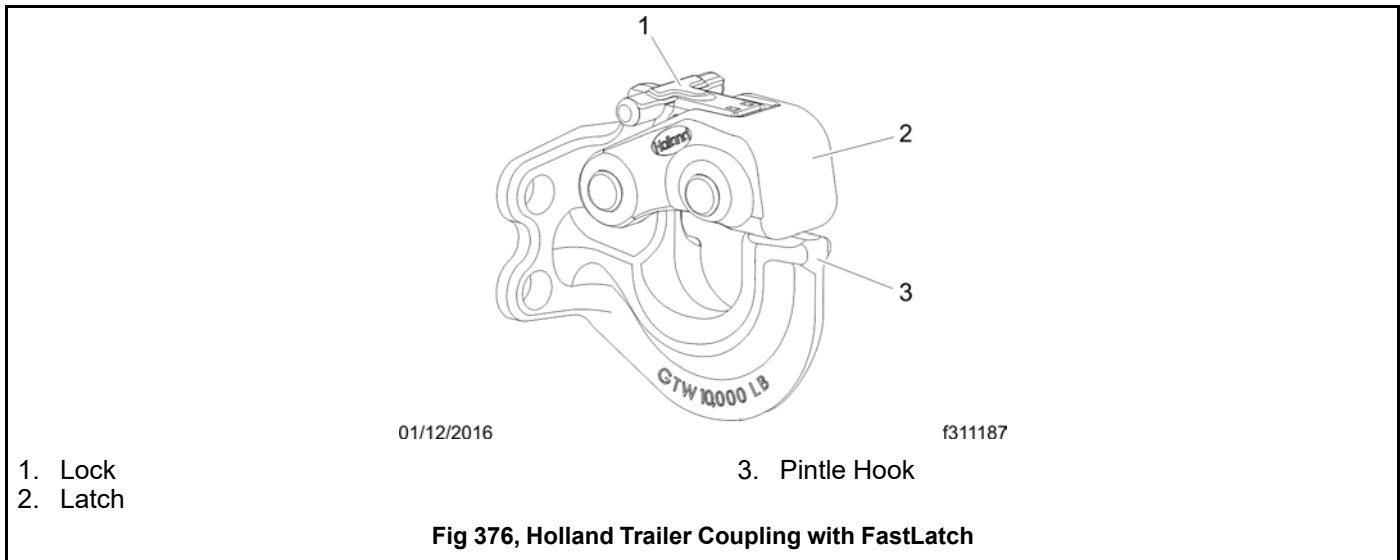

18.05.02 Holland Coupling Trailer Hookup

1. Chock the front and rear tires of the trailer.
2. Remove the lock pin (if equipped), then lift the lock handle and raise the latch.
3. Back up the vehicle until the drawbar eye is over the pintle hook.
4. Lower the trailer, until the drawbar eye rests on the pintle hook.
5. Push the latch closed, then insert the lock pin (if equipped).

6. Connect the trailer electrical and air lines.

**NOTICE:**

Always make sure the connection hanger keeps the trailer air hoses and electrical cables positioned so that they do not rub on anything. Rubbing may wear through hoses or cables, resulting in air leaks, or exposed or broken wires, potentially affecting trailer brake or electrical systems.

18.05.03 Holland Coupling Trailer Release

**WARNING:**

Do not use the trailer air supply for parking trailers not equipped with spring parking brakes. This applies the trailer service brakes only. As air bleeds from the trailer brake system, brake application is lost. This could allow the unattended vehicle to roll away, possibly resulting in serious personal injury or death.

1. Apply the tractor and trailer parking brakes.
2. Chock the front and rear tires of the trailer.
3. Disconnect the trailer air and electrical lines. Plug the air lines to keep them free of dirt.
4. Open the latch by removing the lock pin (if equipped), then lift up the lock and raise the latch.
5. Raise the mating drawbar above the pintle hook. See Fig.328, [Holland Trailer Coupling with Lock Pin](#).
6. Slowly drive the vehicle away from the trailer.

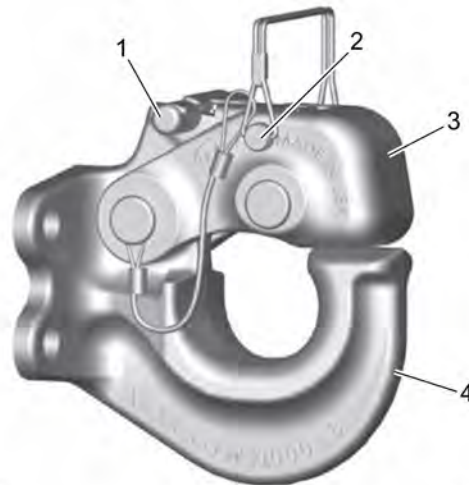

02/17/2017

f311176

1. Lock
2. Lock Pin

3. Latch
4. Pintle Hook

Fig 378, Holland Trailer Coupling with Lock Pin

18.05.04 Premier Air Pintle Hitch Trailer Hookup

1. Chock the front and rear tires of the trailer.
2. Back up the vehicle until the drawbar eye is over the pintle hook.
3. Lower the trailer, until the drawbar eye rests on the pintle hook.
4. Connect the trailer electrical and air lines.

**NOTICE:**

Always make sure the connection hanger keeps the trailer air hoses and electrical cables positioned so that they do not rub on anything. Rubbing may wear through hoses or cables, resulting in air leaks, or exposed or broken wires, potentially affecting trailer brake or electrical systems.

18.05.05 Premier Air Pintle Hitch Trailer Release

1. Apply the tractor and trailer parking brakes.

**WARNING:**

Do not use the trailer air supply for parking trailers not equipped with spring parking brakes. This applies the trailer service brakes only. As air bleeds from the trailer brake system, brake application is lost. This could allow the unattended vehicle to roll away, possibly resulting in serious personal injury or death.

2. Chock the front and rear tires of the trailer.
3. Disconnect the trailer air and electrical lines. Plug the air lines to keep them free of dirt.
4. Raise the drawbar above the pintle hook.
5. Slowly drive the vehicle away from the trailer.

19.01 Before Checking the Headlight Aim.....	364
19.02 Checking Headlight Aim.....	364
19.03 Adjusting the Headlight Aim	366

19. Headlight Aiming

19.01 Before Checking the Headlight Aim

Before checking or adjusting the headlight aim, do the following:

- Check that the hood is closed and latched.
- Check the suspension for proper functioning of the leveling mechanism. On cabs with air suspensions, make sure that the height is properly adjusted.
- If necessary, remove any large amounts of mud or ice from the underside of the fenders.
- Check the springs for sagging or broken leaves.
- Check for damage to the hood and hinge assembly. Repair as necessary.
- With the vehicle unloaded, check that the tires are inflated to the recommended air pressure.
- Clean the headlight lenses. Use a soft cloth with mild, non-caustic soap or detergent, and water.

19.02 Checking Headlight Aim

1. Park the vehicle on a level surface, 25 ft (7.6 m) away from, and perpendicular to, a vertical screen or wall. Shut down the engine and set the parking brake. Chock the tires.
2. Each headlight has a height adjusting dot. See Fig.329,[Headlight Beam Height Adjusting Dot](#). Measure the distance from the ground to the height adjusting dot on each headlight. Note those distances. See Fig. 330,[Headlight Aiming Screen/Wall](#), Ref. A.

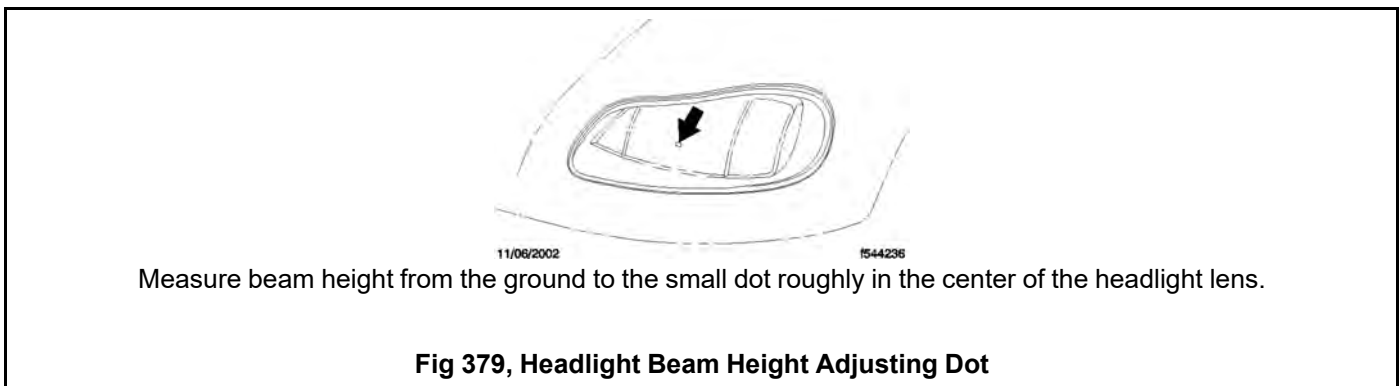

Measure beam height from the ground to the small dot roughly in the center of the headlight lens.

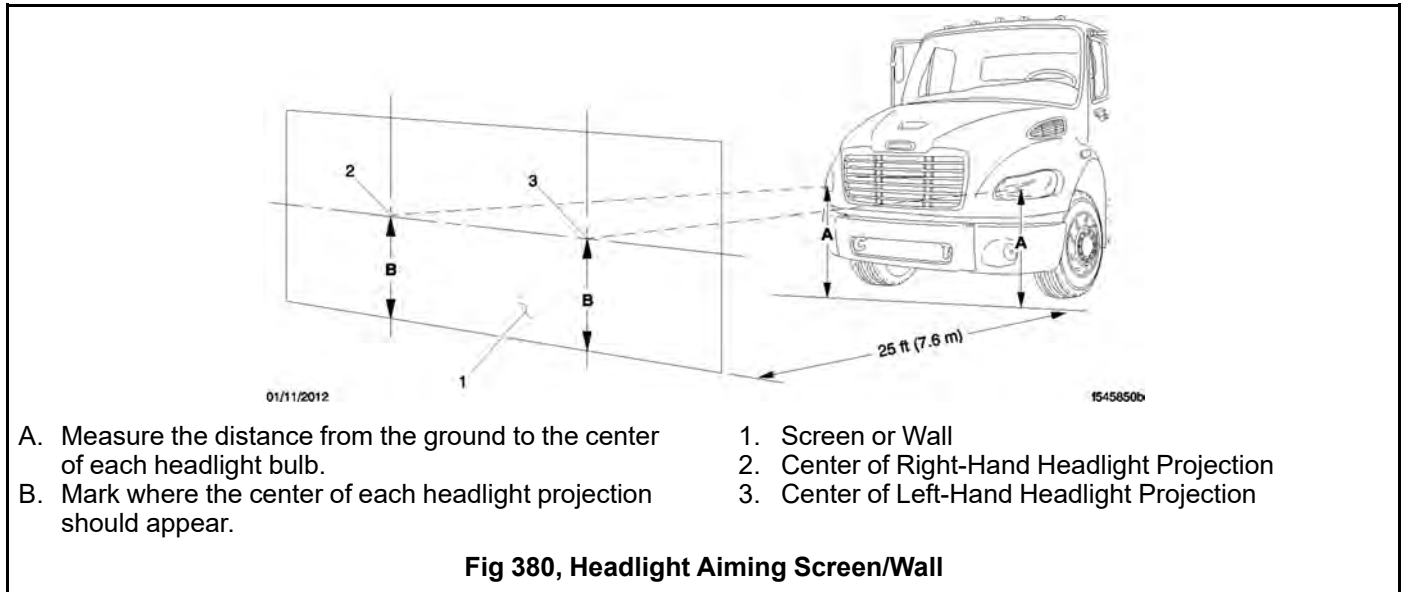

3. Mark the vertical distances found in step 2 on the screen or wall, directly in front of the headlights. These marks represent the desired locations of each headlight bulb center in the following steps. See Fig. 330, [Headlight Aiming Screen/Wall](#), Items 2 and 3.
4. Turn on the low-beam headlights.
5. Identify the center of each beam projection by marking the area of brightest intensity on the wall. The area of brightest intensity should fall on or very near the marks made during step 3. See Fig. 331, [Vertical Low-Beam Headlight Variation Limits](#).

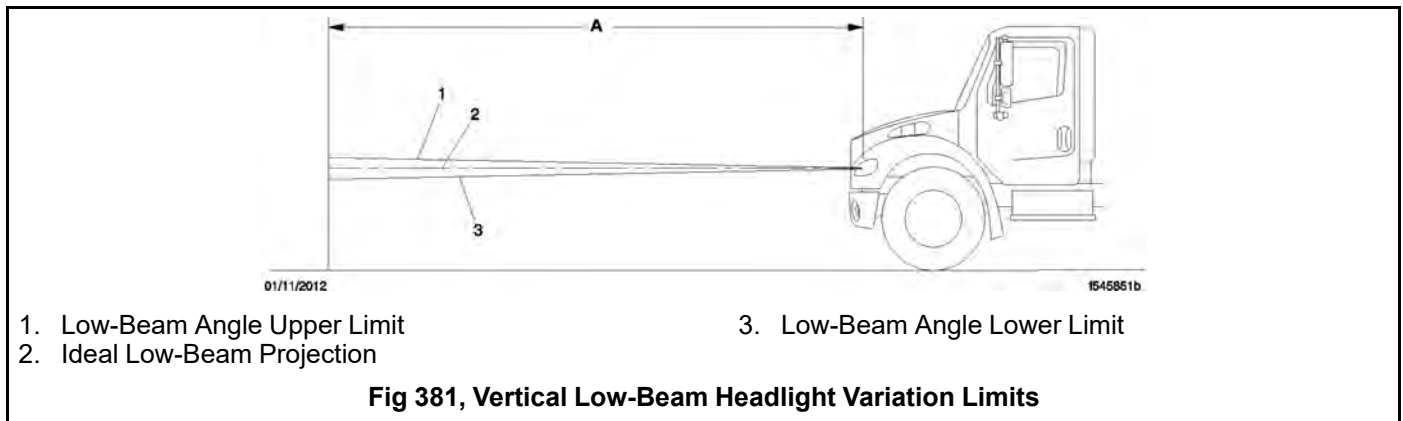

6. See Table.38, [Vertical Low-Beam Headlight Variation Limits](#) to determine the maximum vertical distance allowable between the marks made in step 3 and the marks made in step 5. If the vertical distance between the marks made in steps 3 and 5 is greater than the maximum distance given in Table.38, [Vertical Low-Beam Headlight Variation Limits](#), adjust the vertical positioning of that headlight.

Vertical Low-Beam Headlight Variation Limits			
Distance Between Ground and Headlight: in (mm)	Desired Variation (see 331, Vertical Low-Beam Headlight Variation Limits, Item 2): in (mm)	Upper Limit (see 331, Vertical Low-Beam Headlight Variation Limits, Item 1): in (mm) up	Lower Limit (see 331, Vertical Low-Beam Headlight Variation Limits, Item 3): in (mm) down
22–36 (560–900)	0	3.9 (100)	3.9 (100)
36–48 (900–1200)	2 (50) down	2 (50)	6 (150)
48–54 (1200–1400)	4 (101.6) down	1.6 (40)	6.5 (165)

19.03 Adjusting the Headlight Aim



NOTICE:

Do not use power tools to adjust headlight aim. Doing so will strip or break the adjusting screw.

1. Lift up the splash shield to expose the adjusting knob shown in Fig.332, [Headlight Adjusting Knob](#).

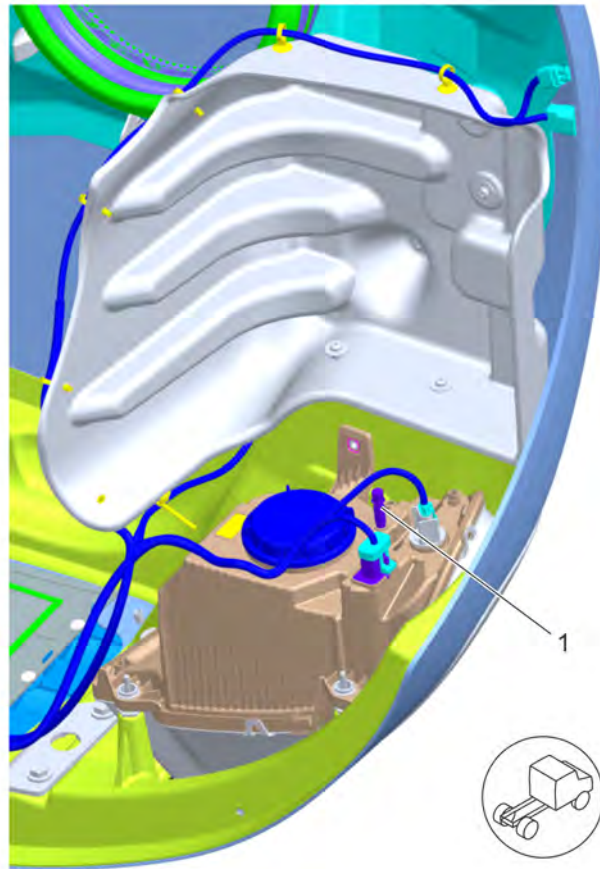

02/08/2022

f547731

The right-hand side headlight bucket is shown. The left-hand side is opposite.

1. Adjusting Knob

Fig 382, Headlight Adjusting Knob

The right-hand side headlight bucket is shown. The left-hand side is opposite.

2. Turn the adjusting screw clockwise to raise the beam of the headlight or counterclockwise to lower it.
3. If necessary, adjust the other headlight.

Vertical Low-Beam Headlight Variation Limits			
Distance Between Ground and Headlight: in (mm)	Desired Variation (see 333, Vertical Low-Beam Headlight Variation Limits, Item 2): in (mm)	Upper Limit (see 333, Vertical Low-Beam Headlight Variation Limits, Item 1): in (mm) up	Lower Limit (see 333, Vertical Low-Beam Headlight Variation Limits, Item 3): in (mm) down
22–36 (560–900)	0	3.9 (100)	3.9 (100)
36–48 (900–1200)	2 (50) down	2 (50)	6 (150)
48–54 (1200–1400)	4 (101.6) down	1.6 (40)	6.5 (165)

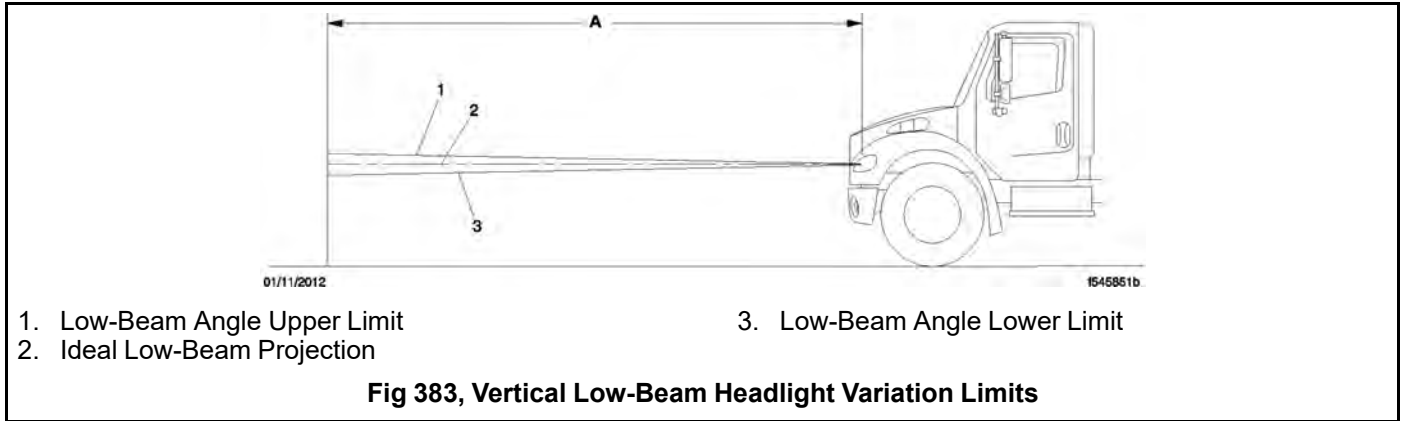

20.01 Natural Gas Vehicles, General Information	370
20.02 Natural Gas Vehicles, Safety Precautions	370
20.02.01 Safety Precautions	370
20.02.02 In Case of Emergency	371
20.03 Natural Gas Engine Starting	371
20.04 Natural Gas Fuel Tank Filling Procedures	372
20.04.01 CNG Vehicle Fueling	372
20.04.02 LNG Vehicle Fueling	375
20.05 Natural Gas Detection System	377
20.05.01 General Information	377
20.05.02 Alarm Procedure	378
20.05.03 Sensors	379
20.05.04 Control Module and Alarm Panel	380
20.05.05 Testing	383
20.06 Major Repair and Replacement of Natural Gas Components	383

20. Natural Gas Vehicle Information

20.01 Natural Gas Vehicles, General Information

The vehicle can be equipped with a compressed natural gas (CNG) fuel system, or a liquefied natural gas (LNG) fuel system.

CNG is made by compressing natural gas to less than 1% of its volume at standard atmospheric pressure. It often contains an odor-producing chemical.

LNG is created by condensing natural gas into a liquid by cooling it to approximately -259°F (-162°C). LNG does not have any odor.

For natural gas to burn, it must first vaporize, then mix with air in the proper proportions (flammable range is 5 to 15% by volume in air), and then be ignited.

A typical natural gas fuel system consists of:

- Fuel supply cylinders that store compressed gas at high pressure (CNG), or a tank that stores liquefied gas at an extremely low temperature (LNG).
- A vaporizer or heat exchanging device that changes LNG to gaseous form (LNG fuel systems only).
- Pressure relief and manual fuel shutoff valves.
- A filling connection with a check valve that prevents the gas from flowing back out of the fuel filling line.
- High-pressure and low-pressure fuel filters.
- A pressure control regulator that reduces the high fuel tank or cylinder pressure to the lower pressure needed for the engine.
- A fuel contents gauge that indicates the fuel supply in the tank or cylinders.

When vaporized at ambient temperatures, natural gas is less dense than air, and it rises and disperses. However, LNG is initially heavier than air due to its cryogenic temperature. When released in large amounts, it may drop or pool on the ground before its temperature rises enough to vaporize. Cold atmospheric conditions may prevent natural gas from dispersing quickly when released in large amounts.

Natural gas is nontoxic, but it can cause asphyxiation if present in very large concentrations.

20.02 Natural Gas Vehicles, Safety Precautions

20.02.01 Safety Precautions

**DANGER:**

Natural gas is highly flammable. Failure to observe the following safety precautions could lead to the ignition of the natural gas, which could cause serious bodily injury or death.

Follow these safety precautions when operating or repairing a natural gas vehicle.

- Do not start the engine if a natural gas leak is detected.
- Do not attempt to cut any fuel supply piping components.
- Avoid open flames or sparks near a natural gas vehicle.
- Cover eyes and exposed skin when working on a natural gas fuel system or fueling a natural gas vehicle.
- Always purge the fuel lines before performing maintenance or repairs on a natural gas fuel system. To purge the lines, close the manual fuel shutoff valve, and start the engine. Let the vehicle idle until the fuel lines are empty and the engine stops.

- Always use a natural gas detector to test the system for leaks, whether an odor is present or not. Routinely inspect the fuel filtering and regulating mechanisms, and the fuel lines. A bubble solution can be used to pinpoint the exact location of leaks.
- Always tighten fasteners and fuel connections to the required torque specification. Over-tightening or under-tightening could cause leaks.
- Close the fuel shutoff valve(s) before performing maintenance and repairs.
- Do not store a natural gas vehicle indoors for any extended period of time. Do not bring a natural gas vehicle indoors unless the workshop is equipped with a methane detection and ventilation system.
- Do not transfer CNG from one vehicle to another, as a buildup of static electricity could cause a spark and ignite the fuel.
- Do not permit smoking or other ignition sources within thirty feet of a natural gas vehicle.
- Have CO₂ fire extinguishers (ABC minimum) located in a highly visible and easily accessible location.
- Use Purple-K powder (PKP) or a similar dry powder to extinguish an LNG fire. Do not attempt use water around an LNG fire.

20.02.02 In Case of Emergency

If a vehicle has sustained damage or a leak has been discovered:

1. Turn the ignition switch off, set the parking brake, and disconnect the battery.
2. Remove all ignition sources from the area surrounding the vehicle.
3. If it is safe to do so, close all fuel shutoff valves.
4. Open the vehicle doors to introduce fresh air.
5. Use a natural gas detector to identify leaks in the fuel system.

20.03 Natural Gas Engine Starting

NOTE: Before starting the engine, see [4.01.01 General Information](#) for detailed information on how to read the instruments and see [5.01 Ignition Switch and Key](#) for detailed information on how to operate the controls. Read the operating instructions in the engine manufacturer's operation manual before starting the engine.

1. Before engine start-up, complete the engine pretrip and post-trip inspections and maintenance procedures, see [23.01 Safety Precautions](#).
2. Ensure the fuel shutoff valve is open.
3. Set the parking brake.
4. Ensure that the transmission shift control is in Neutral (N), Park (P), or the Park Brake (PB) position.
5. Without starting the engine, turn the ignition switch to the ON position. See Fig.334, [Ignition Switch Positions](#). The electronic gauges on the instrumentation control unit (ICU) will complete a full sweep of their dials, the warning and indicator lights will illuminate, and the buzzer will sound for three seconds.

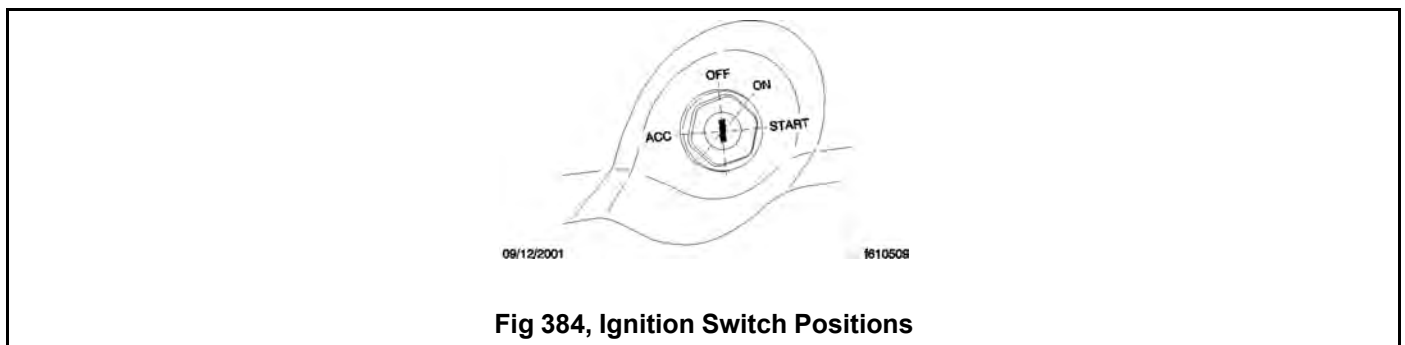

Fig 384, Ignition Switch Positions

6. Turn the ignition switch to the START position.
Press down on the clutch pedal, if equipped, but do not press down on the accelerator pedal.
Release the key the moment the engine starts.
7. Bring the engine up to operating speed gradually as it warms up and develops stable oil pressure. If the vehicle has not been operated previously in a 24-hour period, allow the vehicle to idle for five minutes.

**NOTICE:**

Do not rev the engine if the oil pressure gauge indicates no oil pressure. Shut down the engine within approximately ten seconds to avoid engine damage.

8. Check the oil pressure gauge for any drop in lubricating oil pressure or mechanical malfunction in the lubricating oil system.

20.04 Natural Gas Fuel Tank Filling Procedures

20.04.01 CNG Vehicle Fueling

CNG is moved from the fuel station storage tanks to the vehicle cylinders through a metered dispenser. During fueling, as pressure inside of the vehicle cylinders increases, so does the temperature. The dispenser shuts off when it determines the CNG cylinders are full.

CNG fuel cylinders cannot be filled to their full capacity of 3600 psi (24 800 kPa) in cooler weather. Since temperature change causes gas to expand and contract, less pressure in the cylinders on a cold day is equal to the same amount of gas at a higher pressure on a warm day. The fuel station dispenser has a temperature-pressure compensating device, which accounts for ambient temperature during fueling. See Table.40, [CNG Temperature/Pressure Compensation Values](#) for approximate full cylinder pressures at various temperatures.

CNG Temperature/Pressure Compensation Values		
Temperature: °F (°C)	Fill Station Pressure Set Point	
	3000 psi (20 684 kPa) Set Point	3600 psi (24 821 kPa) Set Point
100 (37.8)	3415 (23 546)	4086 (28 172)
90 (32.2)	3276 (22 587)	3909 (26 952)
80 (26.7)	3138 (21 636)	3754 (25 883)
70 (21.1)	3000 (20 684)	3600 (24 821)
60 (15.6)	2861 (19 726)	3445 (23 752)
50 (10)	2723 (18 774)	3288 (22 670)
40 (4.4)	2584 (17 816)	3131 (21 587)

Table 40, CNG Temperature/Pressure Compensation Values

30 (-1.1)	2446 (16 865)	2973 (20 498)
20 (-6.7)	2307 (15 906)	2814 (19 402)
10 (-12.2)	2169 (14 955)	2655 (18 306)
0 (-17.8)	2031 (14 003)	2495 (17 202)
-10 (-23.3)	1893 (13 052)	2336 (16 106)
-20 (-28.9)	1755 (12 100)	2180 (15 031)
-30 (34.4)	1616 (11 142)	2024 (13 955)
-40 (-40)	1477 (10 184)	1868 (12 879)

Table 32, CNG Temperature/Pressure Compensation Values

Use the following steps to fuel a CNG vehicle.

1. Shut down the engine and apply the parking brake.

**WARNING:**

Natural gas fuel tanks, lines, and valves are always pressurized. Always observe safety precautions. Failure to do so could lead to loss of control over a filling hose or to ignition of the natural gas, which could cause serious bodily injury, death, or severe property damage.

IMPORTANT: Close all windows and doors during the fueling process. Keeping windows and doors closed allows for easier leak detection inside the cab after fueling.

2. Ensure all fuel cylinder shutoff valves are open. See Fig. 335, [CNG Fuel Cylinder Storage Box \(5-cylinder system shown\)](#).

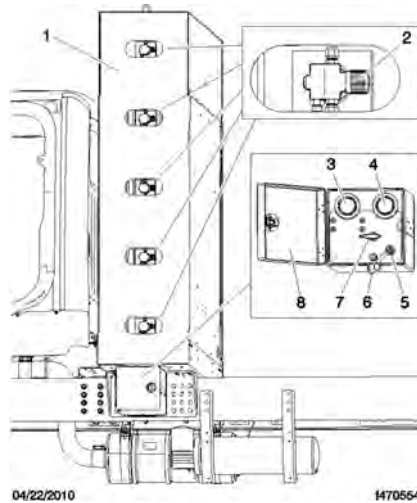

- | | |
|---|---------------------------|
| 1. Fuel Cylinder Storage Box | 5. Fuel Fill Port |
| 2. Fuel Cylinder Shutoff Valves (qty 5) | 6. Dust Cap |
| 3. High-Pressure Gauge | 7. Manual Shutoff Valve |
| 4. Low-Pressure Gauge | 8. Fuel Panel Access Door |

Fig 385, CNG Fuel Cylinder Storage Box (5-cylinder system shown)

3. Ensure the vehicle fuel system main shutoff valve is open.
4. Open the CNG fuel panel access door and remove the dust cap from the vehicle fuel fill port.
5. Ensure the O-ring is present inside the fuel fill port. If the O-ring has been dislodged or is missing, the station dispensing nozzle will not connect securely to the fill port.
6. Turn the selector knob on the service pump to the VENT position, if equipped.
7. Connect the quick coupling on the dispensing nozzle securely to the vehicle fuel fill port.
8. Turn the selector knob on the service pump to the FILL position, if equipped.

IMPORTANT: If at any time the service pump or vehicle begins to vent CNG uncontrollably, notify a station attendant or activate the service station emergency shut-off switch to cease the flow of CNG.

9. Switch on the service pump. A slight hissing noise may be heard as the fuel cylinders fill.
10. Watch the pressure gauge on the service pump. When the gauge reads approximately 3600 psi (24 800 kPa), or when the fill pressure stops climbing, the CNG cylinders are full. The service pump will shut itself down automatically. See [Table.40, CNG Temperature/Pressure Compensation Values](#) for pressure compensation values based on ambient temperatures.
11. Move the selector knob on the service pump to the VENT position, if equipped. A short hiss will be heard as a small amount of natural gas is vented into the hose.

**WARNING:**

Do not attempt to remove the fill station nozzle from the tank fill fitting until venting of pressure is noted. If no venting occurs, ask for assistance from the station attendant. Removing an unvented coupling could result in an uncontrolled hose, which could lead to property damage or personal injury.

12. Remove the station dispensing nozzle from the vehicle fill port.
13. Install the dust cap on the vehicle fuel fill port and close the fuel panel access door.

20.04.02 LNG Vehicle Fueling

The LNG fuel tank is designed to be filled from any LNG fuel source that has a 100 micron or finer fuel filter and a fuel delivery pressure between 120 and 225 psi (827 and 1551 kPa).

The LNG fuel tank is designed to be top-filled through a single hose with no vent return. As cold LNG is sprayed into the vapor space of the tank, the cold liquid condenses the vapor and creates space for itself inside the tank, eliminating any need to vent during the filling process.

The LNG tank is equipped with a small internal ullage tank for vapor space, which allows for fuel expansion and increases vehicle standby time. When an LNG tank is full, fuel can continue to flow into the ullage tank. However, if the ullage tank is completely filled during fueling, standby time will be reduced to zero and the primary relief valve will open almost immediately after fueling, allowing excess LNG vapor to escape. If fueling is stopped when the ullage tank is empty (i.e., the fuel tank has sufficient vapor space to accommodate fuel expansion due to temperature increase), the vehicle will have approximately one week of standby time before venting will occur.

Use the following steps to fuel an LNG vehicle.

1. Shut down the engine and apply the parking brake.

**WARNING:**

Liquefied natural gas is a cryogenic liquid stored at approximately -259°F (-162°C). Cryogenic burns can be caused by coming into contact with the pressurized liquid stream, or by coming into contact with fuel system components that have been cooled to cryogenic temperatures. Always wear gloves and a face shield, and cover exposed skin when fueling.

IMPORTANT: Close all windows and doors during the fueling process. Keeping windows and doors closed allows for easier leak detection inside the cab after fueling.

2. Remove the fuel fill fitting dust cap. See Fig.336, [LNG Fuel Tank](#).

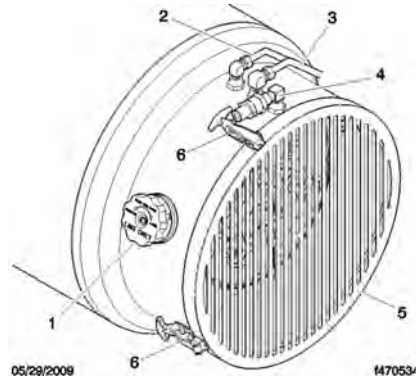

- | | |
|-----------------------------|-------------------------|
| 1. Fuel Fill Fitting | 4. Fill Vent Fitting |
| 2. Fuel Outlet Line | 5. Shroud Cover |
| 3. Primary Relief Vent Line | 6. Shroud Cover Latches |

Fig 386, LNG Fuel Tank

- Using compressed air, remove any dirt, debris, or water that may have collected in the fuel fill fitting and the station dispensing nozzle. Contaminants in the fuel system can cause drivability problems.



WARNING:

Natural gas fuel tanks, lines, and valves are always pressurized. Always observe safety precautions. Failure to do so could lead to loss of control over a filling hose or to ignition of the natural gas, which could cause serious bodily injury, death, or severe property damage.

- Connect the station fueling nozzle to the tank fuel fill fitting.
- Connect an electrical ground clamp and cable to the fuel tank.

IMPORTANT: An LNG tank which is first installed, or is on a vehicle that has not been operated in approximately ten days, is considered to be a hot tank. When fueling a hot tank, LNG entering the tank will immediately vaporize, causing tank pressure to spike above 250 psi (1724 kPa) and automatically shutting down the station fuel pump. To prevent the pump from shutting down, connect a vent line to the fill vent fitting on the LNG tank to capture escaping vapor, then open the shroud cover and open the vapor shutoff valve (see Fig.337., page 377, Item 2).

- Open the station's fill valve, if equipped, and start fueling. Monitor the flow or line pressure as filling progresses. When filling begins, line pressure will spike quickly until the vehicle tank cools down. The flow and pressure will then remain stable during the remainder of the filling procedure.

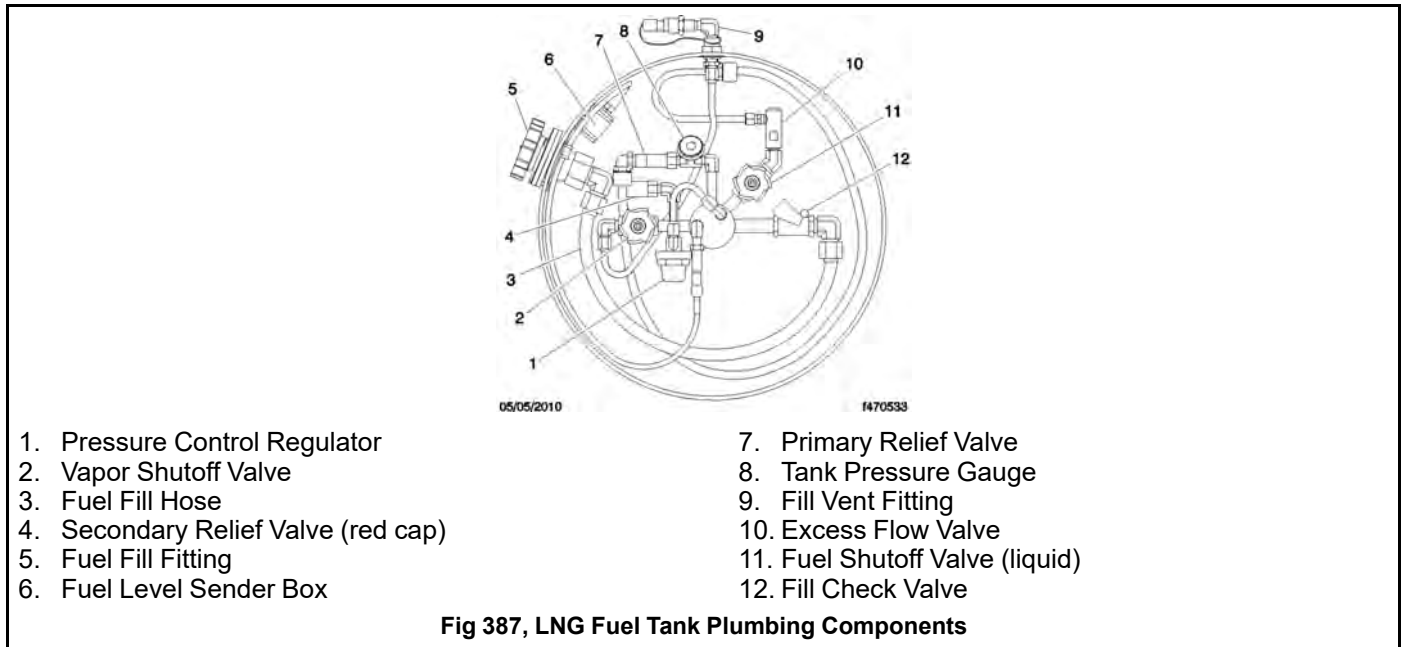

IMPORTANT: When fueling a hot tank, initially put 5 to 10 gallons (19 to 37 liters) of LNG in the tank and manually stop the fueling process. Drive the vehicle for 15 to 20 minutes to cool the tank and reduce tank pressure, then continue fueling the tank to full.

- When the tank is full, the line pressure will rapidly spike and the flow rate will fall. When a pressure rise or flow rate drop is observed, close the station's fill valve, if equipped.

NOTE: Do not over-fill an LNG tank. If the ullage tank is completely filled during fueling, tank standby time will be reduced to zero and the primary relief valve will open almost immediately after fueling.

- Disconnect the station hose from the tank fuel fill fitting.
- Disconnect the electrical ground clamp and cable from the fuel tank.
- Install the dust cap on the tank fuel fill fitting.

20.05 Natural Gas Detection System

20.05.01 General Information

A gas detection system is standard equipment in all Daimler Truck natural-gas-fueled vehicles. This system has a sensor in the engine compartment and one in the cab, both situated in high areas to detect natural gas buildup as a result of leaks. This device is meant to serve as a supplemental warning only. It is not intended to replace standard safety practices that should be conducted around flammable gases.

IMPORTANT: To function properly, the gas detection system must be powered at all times. The gas detection system is directly powered by the batteries, and can only be powered off by disconnecting the batteries. When servicing a natural-gas-fueled vehicle, disconnect the batteries only when necessary, and do not leave the batteries disconnected for extended periods of time.

The lower flammability limit (LFL) is the smallest amount of the gas that supports a flame when mixed with oxygen and ignited. Zero percent (0%) LFL indicates a gas-free atmosphere. One hundred percent (100%) LFL indicates that gas

concentration has reached its lower flammability limit (5% gas in air by volume). The red warning light and audible alarm located in the overhead console activate when a sensor detects gas fumes in concentrations above 50% LFL, and should allow ample time to utilize safety procedures. However, individuals with special needs should review the system with a professional safety engineer.

20.05.02 Alarm Procedure

Before operating the vehicle, the driver must be familiar with the procedures as shown on the interior sticker on the overhead panel (see Fig.338, [Interior Warning Sticker](#)) and the exterior sticker on the door (see Fig. 339, [Exterior Warning Sticker](#)).



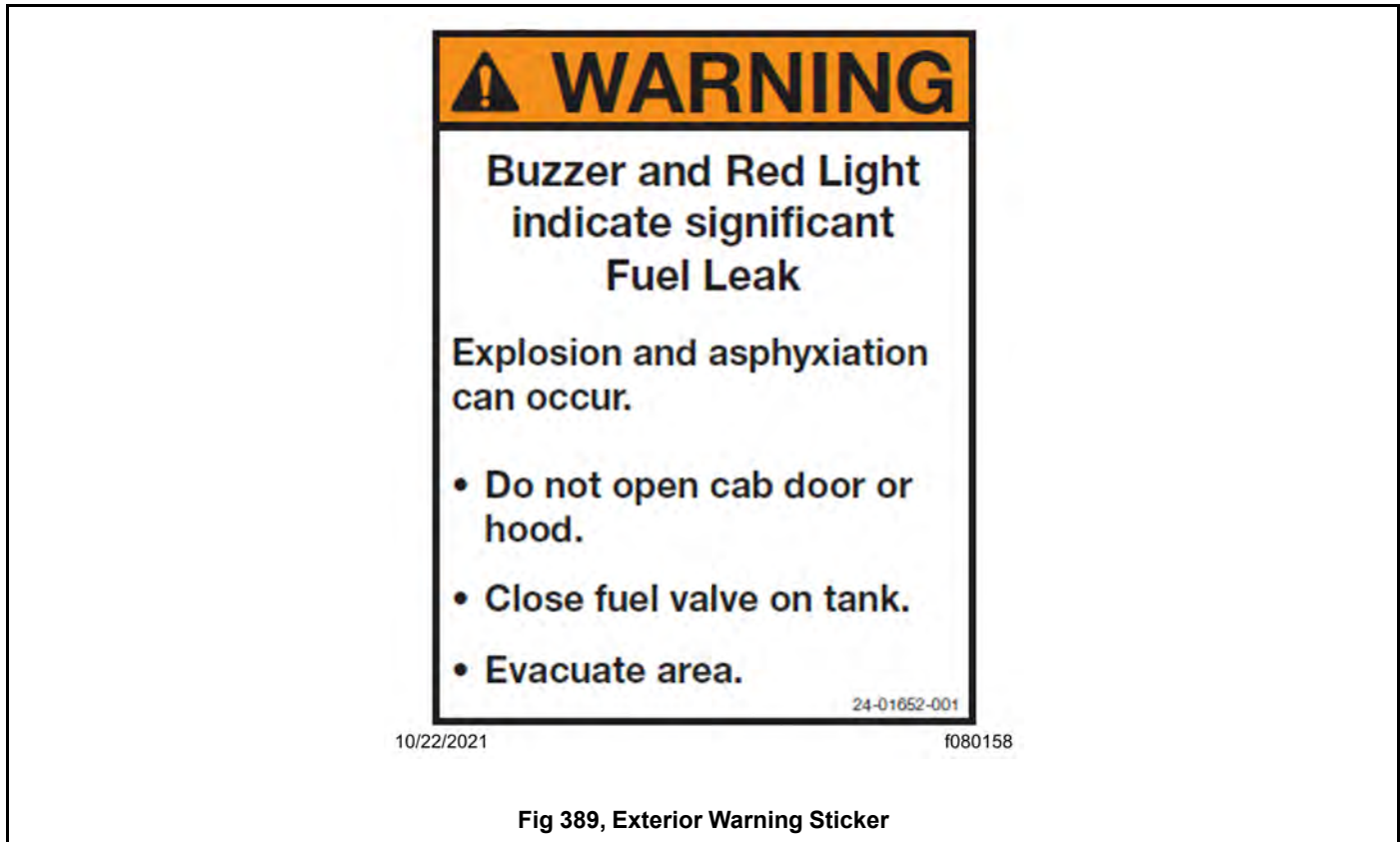

IMPORTANT: If an audible alarm activates, do not operate any electrical switch, including lights. Avoid causing sparks and stay away from arcing switches and equipment. Do not use a telephone, including cellular phones or any types of portable communication or electronic devices that have a battery.

If the vehicle is in motion when the audible alarm activates, bring it to a safe stop, shut down the engine, and exit the vehicle. *Do not open the hood.*

If outside the vehicle when the audible alarm activates, *do not open the cab door or hood.*

In the event of an audible alarm, immediately follow these procedures, as allowed by conditions:

- Immediately shut off all engines. Extinguish any cigarettes, pilot lights, flames, or other sources of ignition in the area and adjacent areas.
- Manually close all fuel shutoff valves, including those on the LNG tank or CNG cylinders.
- If the vehicle is indoors (as in a service shop), immediately open windows and doors to provide extra ventilation to the area. Do not start the engine or any other type of equipment until the gas leak is corrected and the area cleared of natural gas.
- Evacuate the area.
- Check the fuel lines, LNG tank/CNG cylinders, and fittings to locate the leak. After the area is cleared of natural gas and the alarm is no longer active, have the vehicle inspected by a qualified technician.

IMPORTANT: Do not consider the area clear until all alarm indicators are off, and the alarm panel light returns to green.

20.05.03 Sensors

Gas detection sensors are located on the cab overhead console and in the engine compartment on the frontwall. The sensors are located in high areas, where rising gas vapors will pass by or accumulate.

If the system detects that one of the sensors has been disconnected or has malfunctioned, the sensor fault light for that zone will illuminate. A failed sensor may trigger and lock on an alarm. If a fault condition or locked alarm continues after the sensor's connection and wiring integrity has been verified, replace the sensor.

The sensors are sensitive to all hydrocarbon vapors. An alarm may be triggered by the use of chemicals such as cleaners, paint, polish, lacquer, gasoline, silicone, silicone spray, or other harsh chemicals. The sensors will also detect hydrogen fumes from an overcharged battery. If a sensor sends an alarm, but no gas fumes are present, check for recent use of chemicals or a battery charger.

**NOTICE:**

Silicone-based chemicals and cleaners will permanently disable the sensors. When cleaning the vehicle, cover the sensors with a plastic covering. Keep the sensors covered until the area has been cleared of any cleaning fumes.

Harsh chemicals and extremely high temperatures may damage the sensor.

Puncture of or damage to the seal located inside the sensor housing will significantly shorten the sensor life.

Frequent exposure to high concentrations of gas will accelerate sensor deterioration.

20.05.04 Control Module and Alarm Panel

The gas detection system control module is located on the center dash panel. See Fig.340, [Control Module](#). The alarm panel is located on the overhead consol. It has a green light, a red light, a buzzer, and a sensor. See Fig. 341, [Alarm Panel \(overhead console\)](#). It is located within view from outside of the vehicle. The large green light is continuously illuminated during normal operating conditions. There is also a forward-facing alarm panel located at the top center of the windshield for easy viewing from the front of the vehicle. This panel only has the green and red lights. See Fig. 342, [Alarm Panel \(upper windshield\)](#).

Before entering the vehicle, always verify that the green light is illuminated. If the green light is not illuminated, do not enter the vehicle. Complete the alarm procedure previously outlined.

The control module and the alarm panels meet the California Highway Patrol Title 13-2008 and NFPA 52 2010 requirements. All drivers and technicians using it should be trained regarding the red and green lights, and the audible warning.

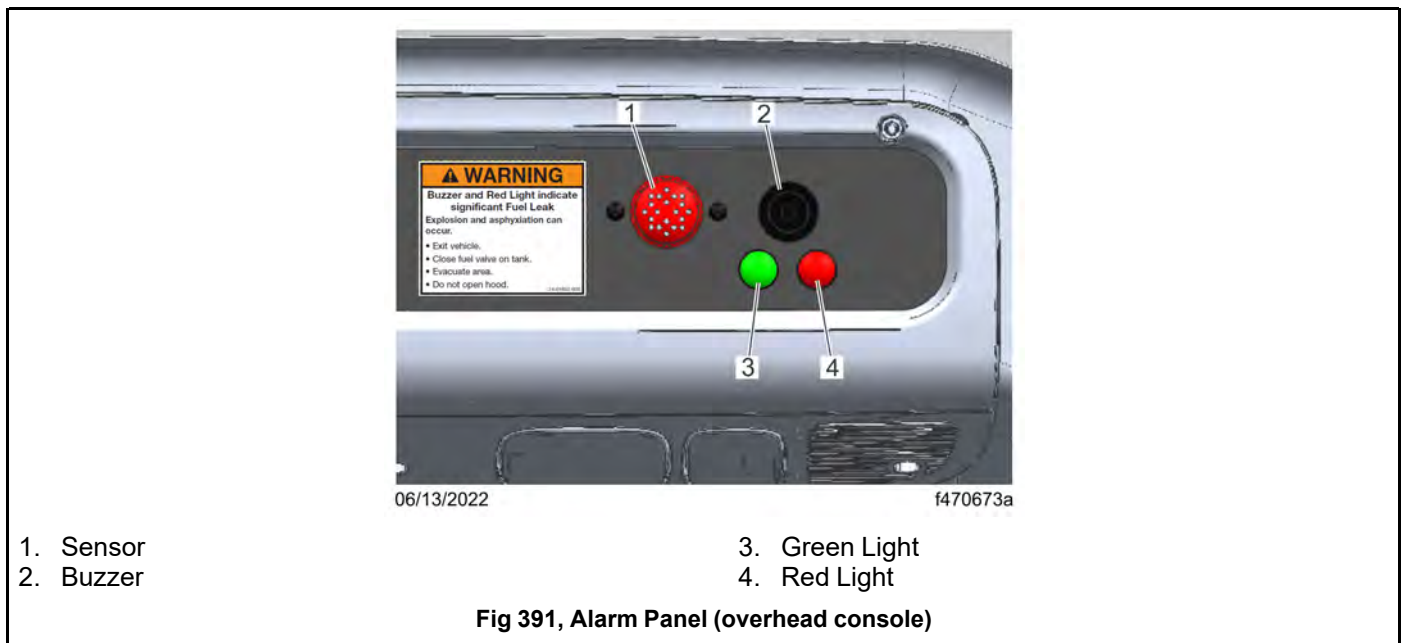
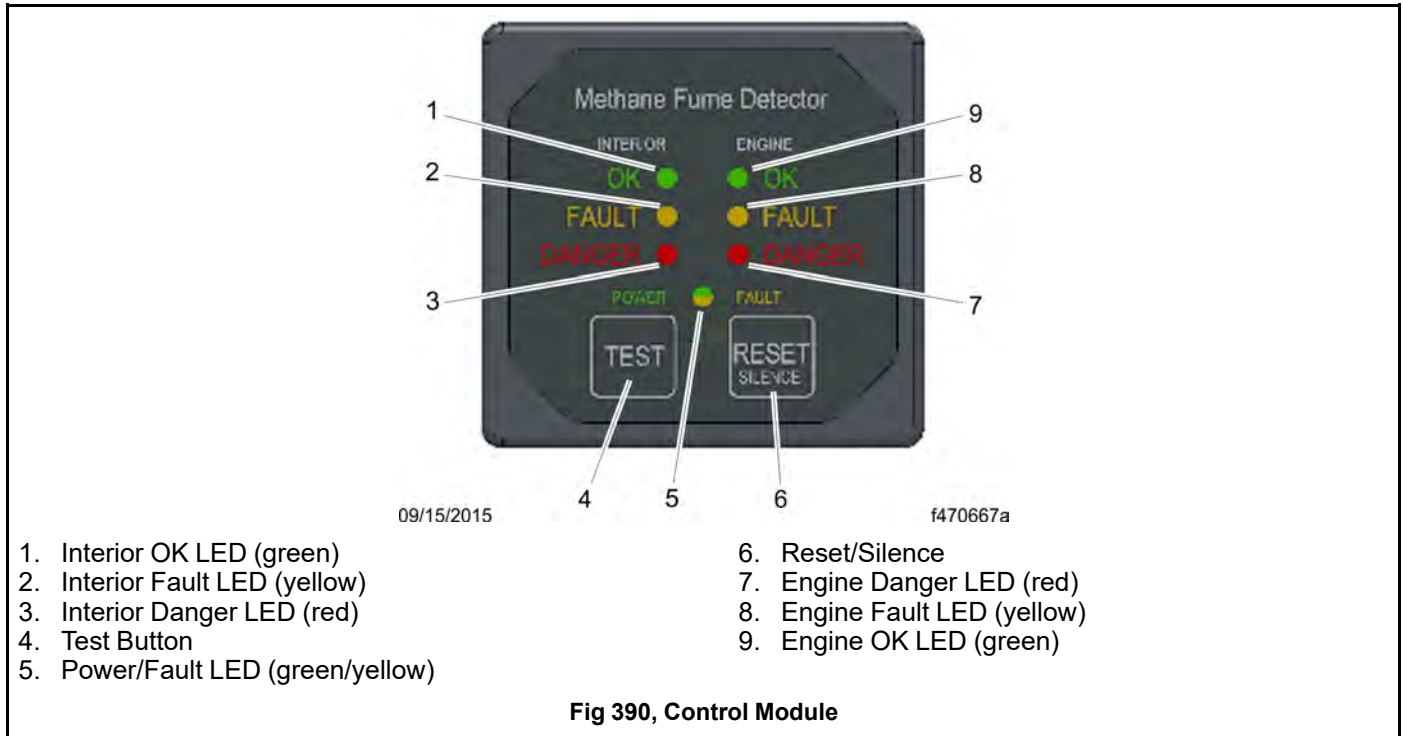

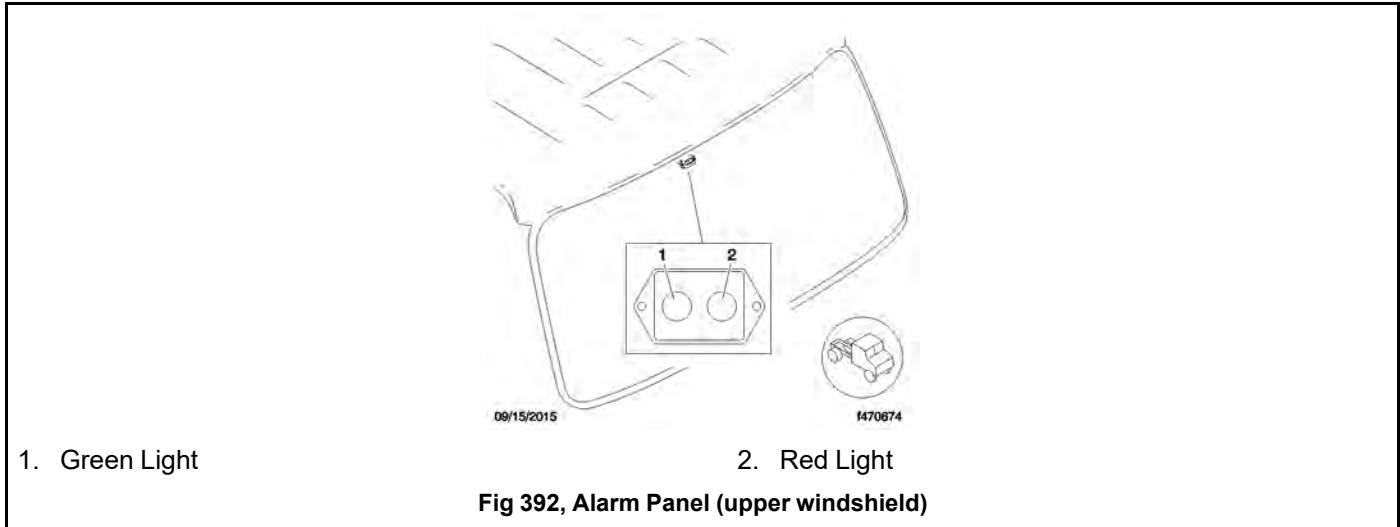

The control module, located on the center dash panel, contains the status lights and control buttons for the system. The areas that the sensors monitor are defined as Zone 1 (cab interior) and Zone 2 (engine compartment). The control module has lights assigned to each zone that will illuminate if a sensor detects a trace level leak (between 20% and 50% LFL), Or a dangerous leak (above 50% LFL), or if a sensor is disconnected or malfunctioning.

- Green: System is functioning properly.
- Amber: If the system detects that either of the sensors has been disconnected or has malfunctioned, an amber light next to the "FAULT" indicator for that zone will illuminate.
- Red: If either sensor detects gas fumes at a concentration greater than 20% (2.5% gas in air by volume), the small red light next to the "DANGER" indicator for that zone will flash. After approximately 15 seconds, the large green light on the alarm panel will switch off, the red light will illuminate, and the buzzer will sound. All alarm indicators will remain on as long as fumes are detected.

The control module also has buttons used to test or reset the control module and silence the buzzer after an alarm.

- TEST: Press the "TEST" button to test the LED and output operation.
- Reset/Silence: If an alarm has been activated, the "RESET/SILENCE" button will silence the buzzer.

See Table.41, [Control Module Functions](#) for the functions of all lights and buttons on the control module.

Fireboy Control Module Functions			
Item	Display	Function	Action Required
Interior OK LED (green)	Illuminated	Interior sensor is detected, signal is OK, and system power is on.	None required.
Interior Fault LED (yellow)	Illuminated	Interior sensor is not detected, or there is a signal malfunction.	Have the system checked immediately.
Interior Danger LED (red)	Illuminated	Interior sensor is reading an amount of gas greater than 20% LFL.	Suspend vehicle operation immediately and follow alarm procedures.

Table 41, Control Module Functions

Test Button	—	Cycles the LEDs and triggers the relay temporarily.	Press and hold for one minute to activate a test of all control module components.
Engine OK LED (green)	Illuminated	Engine sensor is detected, signal is OK, and system power is on.	None required.
Engine Fault LED (yellow)	Illuminated	Engine sensor is not detected, or there is a signal malfunction.	Have the system checked immediately.
Engine Danger LED (red)	Illuminated	The engine sensor is reading an amount of gas greater than 20% LFL.	Suspend vehicle operation immediately and follow alarm procedures.
Reset/Silence	—	Turns the relay off when in alarm mode.	Press the button.
Power/Fault LED (green/yellow)	Illuminated (green)	System is on.	None required.
	Illuminated (yellow)	Not used.	Not used.
Buzzer	Sounding	Gas is detected at a level above 50% LFL in the specified zone.	Suspend vehicle operation immediately and follow alarm procedures.

Table 33, Control Module Functions

20.05.05 Testing

Daimler Truck North America strongly recommends that all operators follow California Code of Regulations (CCR) inspection requirements, regardless of where the vehicle is operated. Per Title 13 CCR § 935 (2), gas detection systems should be tested three times per calendar year at equal intervals. The testing procedure should simulate the same operating environment in which the vehicle is used, with the same gaseous fuel.

Test results validating the performance of the gas detection system within the parameters established by the component manufacturer and NFPA 52 2010 should be maintained as a permanent part of the vehicle service records. Use of alcohol, propane, and other harsh liquids or gases are not acceptable methods for testing.

Always test the system and sensors after any component has been replaced, or if the vehicle has been involved in an accident or fire. Ensure that the gas detection system is wired directly to the battery.

It is recommended that the highest level of safety validation be utilized if there are multiple validation requirements in the state or locality where the vehicle is operated or domiciled.

Control Module Console Test

Press and hold the *Push To Test* button for one minute. The system will proceed with a self-diagnostic test that will include illumination of the *Trace* and *SIGNIFICANT* gas concentration lights, and the sensor fault lights. Verify the large red light and buzzer activate, and that all lights illuminate or flash to ensure that all bulbs are operational.

Sensor Test

The gas detection system sensors must be tested regularly by a trained technician, using certified test equipment that satisfies CCR § 935 (2) or NFPA 52 regulations.

20.06 Major Repair and Replacement of Natural Gas Components

If a natural-gas-fueled vehicle is involved in an accident, remove the fuel tank or cylinders from service and have them inspected by a qualified technician. Replace any leaking or damaged fuel tanks/cylinders and fuel lines; repair or replace leaking or damaged fittings. Install parts and components in accordance with the manufacturer's instructions.

21.01 Cleaning and Disinfecting Cab Surfaces 386

 21.01.01 Safety 386

 21.01.02 Cleaning and Disinfecting High-Touch Surfaces 386

 21.01.03 Dashboard and Touch Screen Care 387

 21.01.04 Cleaning and Disinfecting Chemicals to Avoid 387

21.02 Cleaning the Upholstery 388

 21.02.01 General Information 388

 21.02.02 Cleaning Cloth Seats 388

 21.02.03 Faux Leather Cleaning 388

 21.02.04 Vinyl Upholstery Cleaning 388

21.03 Washing and Polishing the Cab 389

 21.03.01 Protecting Your Vehicle's Finish 389

 21.03.02 Keeping Your Vehicle Looking New 390

 21.03.03 Protecting Vehicle Labeling 390

21.04 Care of Exterior Lights 390

21.05 Caring for External Chrome Components 390

21.06 Care of Fiberglass Parts 391

21. Vehicle Appearance and Care

21.01 Cleaning and Disinfecting Cab Surfaces

21.01.01 Safety

The following guidelines are for cleaning and disinfecting commonly touched surfaces on the inside and outside of a vehicle.

For best results, follow cleaning and disinfecting procedures fully and consistently. Ensure there is adequate ventilation when using chemicals.

- Doors and windows should remain open when cleaning inside the vehicle.
- When cleaning and disinfecting, individuals should wear disposable gloves compatible with the products being used as well as any other personal protective equipment (PPE) required according to the product manufacturer's instructions and the safety data sheet (SDS).
- Gloves and any other disposable PPE used for cleaning and disinfecting the vehicle should be removed and disposed of after use.
- Wash hands with soap and water for at least 20 seconds immediately after removal of gloves and PPE, or use an alcohol-based hand sanitizer with at least 60 percent alcohol.

21.01.02 Cleaning and Disinfecting High-Touch Surfaces

NOTE: Depending on how a vehicle is used, it may be helpful to create an inclusive checklist of high-touch surfaces to regularly clean.

To clean surfaces, soak a microfiber cloth with a detergent/water solution, wring the cloth out, and wipe down high-touch areas. Allow the detergent water/solution to sit on the surface for 20-30 seconds before using a fresh microfiber cloth slightly dampened with water to remove it.

After this soap and water wash, Freightliner recommends the use of either a dilutable or ready to use quaternary ammonium based disinfectant on vehicle interior and exterior surfaces.

IMPORTANT: Follow the manufacturer's instructions for using a disinfectant as these vary by product.

**NOTICE:**

Any disinfectant dispensed by a pressurized aerosol container is not recommended. The direct spray of liquids onto the vehicle's interior panels, electronic components, or permeable materials is not recommended.

Using an aerosol disinfecting spray may cause damage to parts of the vehicle.

Examples of either a dilutable or ready to use quaternary ammonium based disinfectant include:

- Lysol® Deodorizing Disinfectant Cleaner
- Fantastik® Disinfectant Multi-Purpose Cleaner
- Hillyard Vindicator®+ Disinfectant

All exterior high-touch surfaces should be cleaned with soap and water before applying disinfectant.

Exterior high-touch surfaces include, but are not limited to, the following:

- grab handles
- door handles
- hood latches and handles
- trailer glad hands

Freightliner recommends applying the disinfectant solution to a microfiber cloth until it is damp but not dripping and then wiping down high-touch areas. Take care to fully wet surfaces with the disinfectant, and ensure that it remains wet for the period of time stipulated by the disinfectant manufacturer to effectively disinfect the surface. Afterwards, if necessary, wipe off excess disinfecting solution with a new clean cloth.

If an interior high-touch surface is visibly dirty, clean it before applying disinfectant; if it appears clean, wipe down the area with disinfectant.

Interior high-touch surfaces include, but are not limited to, the following:

- grab handles
- seats
- arm rests
- steering wheel
- switch pods
- shift knob
- door handles
- seat belt buckles
- light and air controls
- doors and windows

21.01.03 Dashboard and Touch Screen Care

**NOTICE:**

When cleaning the dashboard do not use Armor-All Protectant®, STP Son-of-a-Gun®, window cleaner, or other equivalent treatments. These cleaners contain vinyl plasticizers which can cause stress crazing and cracking in the interior plastic panels. This type of damage is not covered by vehicle warranty.

Wipe down fragile components carefully to avoid damaging the vehicle.

Do not directly spray the screen or any other device in the vehicle. Do not use soap and water on a touch screen. Excess water or disinfectant will damage electrical components.

If the vehicle contains a touch screen, follow the manufacture's instructions for cleaning and disinfecting it. If manufacturer guidance is unavailable, spray a lint-free cloth with a mix of at least 70 percent isopropyl alcohol and distilled water and gently wipe down the screen and then dry it with a clean cloth.

21.01.04 Cleaning and Disinfecting Chemicals to Avoid

Unless specifically specified, Freightliner vehicles should **not** be cleaned or disinfected with products that contain the following chemicals:

- hydrogen peroxide
- sodium chlorite
- sodium hypochlorite (chlorine bleach)
- glycol acid
- octanoic acid
- hypochlorous acid
- silicone

21.02 Cleaning the Upholstery

21.02.01 General Information

NOTE: Using diluted laundry detergent to clean cloth seats may create excess suds.

To prevent soiling, frequent vacuuming or light brushing to remove dust and dirt is recommended. In most cases, quickly wiping down a seat with a damp cloth will remove dirt, spills, and pet hair.

To preserve the upholstery and prevent damage, review the following sections for recommended cleaning procedures.

21.02.02 Cleaning Cloth Seats

Vacuuming cloth seats regularly and quickly wiping down the seats with a damp cloth to remove dirt, debris, spills, and pet hair should keep the seats looking new.

For resistant or greasy stains, spray a small amount of upholstery cleaner on the stain, work it in with a small scrub brush, and let it sit for fifteen minutes prior to wiping it up. For larger areas, start at the top of the stained area so any dirty solution drips down. Follow any product label directions about diluting the cleaner prior to use.

If seats are deeply soiled, clean in multiple rounds or, if possible, remove the seat covers and wash them in a washing machine.

CODURA® cloth seats: If needed, apply a mild liquid soap to a damp cloth and rub the stained area. Follow this with wiping down the area with a clean water dampened cloth. Allow seats to dry before using them. Spray-on upholstery cleaners can also be used and then vacuumed off.

Durawear™ cloth seats: Durawear fabric is coated with PVC on the backside, making the seats waterproof. Start cleaning with a water dampened cloth. If needed, use upholstery cleaner or, if the seat covers are removable, wash them in washing machine. Do not dry Durawear seat covers in a dryer. Allow seat covers to air dry before using.

If needed, Durawear seats can be disinfected by wiping them down with solution consisting of 10 percent bleach and 90 percent water.

Fabriform® seats: Fabriform is a tri-laminate of film, foam, and fabric with superior wear resistance. To clean dirt, stains, and spills, wipe with a damp cloth. If needed, scrub with a soft scrub brush with mild soap or use an upholstery cleaner. Fabriform seats can be hosed off, if necessary.

21.02.03 Faux Leather Cleaning

In general, faux leather seats can be wiped clean with a rag and warm water.

Water-soluble spills and stains can be removed with mild soap and water. Gently wipe the stain with a soapy cloth or sponge. After cleaning the stain or spill, remove any remaining soap solution by wiping the area with a cloth and clean water. As a final step, dry the surface with a soft lint-free cloth or towel.

Non-water soluble stains caused by oils, such as lotions and foods, can be cleaned with 50 percent solution of isopropyl alcohol and water. Rinse the cleaned area with water after applying the alcohol solution. Dry with a clean, lint-free cloth.

Faux leathers can be disinfected by wiping them down with solution consisting of 10 percent bleach and 90 percent water. After disinfecting, wipe down with a clean damp cloth and then dry with a clean dry cloth.

Avoid cleaners containing abrasives, as these can damage the product's coating.

21.02.04 Vinyl Upholstery Cleaning

Harsh cleaning agents can cause permanent damage to vinyl upholstery. Waxing or refinishing improves soil resistance for all vinyls.

Ordinary Dirt

Wash the upholstery with warm water and mild soap, such as saddle or oil soap. Apply soapy water to a large area and let it soak for a few minutes, then rub briskly with a cloth to remove the dirt. This can be repeated several times, as necessary.

If dirt is deeply imbedded, use a soft bristle brush after applying the soap.

If dirt is extremely difficult to remove, wall-washing preparations normally found around the home can be used.

Powdered cleaners, such as those used for sinks and tiles, are abrasive and must be used with caution as they can scratch the vinyl or give it a permanent dull appearance.

Chewing Gum

Harden the gum with an ice cube wrapped in a plastic bag, then scrape it off with a dull knife. Any remaining traces of gum can be removed with an all-purpose light oil (peanut butter will also work) and wiped off.

Tars, Asphalts, and Creosote

Each of these items stains vinyl after prolonged contact. They should be wiped off immediately and the area carefully cleaned, using a cloth dampened with naphtha.

Paint, Shoe Heel Marks

Paint should be removed immediately. Do not use paint remover or liquid-type brush cleaner on vinyl. An unprinted cloth, dampened with naphtha or turpentine may be used. Use care to prevent contact with parts of the upholstery that are not vinyl.

Sulfide Stains

Sulfide compounds, such as those found in eggs and some canned goods, can stain after prolonged contact with vinyl. These stains can be removed by placing a clean, unprinted piece of cloth over the spotted area and pouring a liberal amount of 6 percent hydrogen peroxide onto the cloth. Allow the saturated cloth to remain on the spot for 30 to 60 minutes. For stubborn spots, allow the hydrogen-peroxide saturated cloth to remain on the area overnight. Use caution to prevent the solution from seeping into the seams, or it will weaken the cotton thread.

Nail Polish and Nail Polish Remover

Prolonged contact with these substances causes permanent damage to vinyl. Careful blotting immediately after contact minimizes damage. Do not spread the liquid during removal.

Shoe Polish

Most shoe polishes contain dyes which penetrate vinyl and stain it permanently. Shoe polish should be wiped off as quickly as possible using naphtha or lighter fluid. If staining occurs, try the procedure used for sulfide stains.

Ball Point Ink

Ball point ink can sometimes be removed if rubbed immediately with a damp cloth, using water or rubbing alcohol. If this does not work, try the procedure used for sulfide stains.

Miscellaneous

If stains do not respond to any of the treatments described above, it is sometimes helpful to expose the vinyl to direct sunlight for up to 30 hours. Mustard, ball point ink, certain shoe polishes, and dyes often bleach out in direct sunlight, leaving the vinyl undamaged.

21.03 Washing and Polishing the Cab

21.03.01 Protecting Your Vehicle's Finish



NOTICE:

When pressure washing the vehicle or leaving the hood open when parked outdoors and subject to rain, cover the air cleaner inlet with a plastic bag to prevent water from entering the air intake system and possibly damaging the engine.

IMPORTANT: Carefully read all instructions before using or applying any cleaner or product on the vehicle or components. Failure to follow manufacturers' recommendations can result in damage to the finish.

To protect the finish of your new vehicle, follow these guidelines carefully:

- During the first 30 days, rinse your vehicle frequently with water. If the vehicle is dirty, use a mild liquid soap. Do not use detergent.
- During the first 30 days, do not use anything abrasive on your vehicle. Brushes, chemicals, and cleaners may scratch the finish.
- During the first 120 days, do not wax your vehicle.

21.03.02 Keeping Your Vehicle Looking New

To extend the life of your vehicle's finish, follow these guidelines:

- Avoid washing your vehicle in the hot sun.
- Always use water. After the cab is completely washed, dry it with a towel or chamois.
- Do not dust painted surfaces with a dry cloth, as this will scratch the paint.
- Do not remove ice or snow from a painted surface with a scraper of any sort.
- To prevent damage to the finish, wax it regularly. If the finish has become dull, before waxing, remove oxidized paint using a cleaner specifically designed for this purpose. Remove all road tar and tree sap before waxing. Freightliner recommends that a quality brand of cleaner or cleaner-polish and polishing wax be used.
- Do not let diesel fuel or antifreeze stand on a painted surface. If either should occur, rinse the surface off with water.
- To prevent rust, have any nicks or other damage on the finish touched up as soon as possible.
- Park your vehicle in a sheltered area whenever possible.

21.03.03 Protecting Vehicle Labeling

A majority of the labels applied to cab are required for reasons of safety or identification. To prevent delamination and deterioration of labels and stickers, follow these guidelines carefully:

- Do not pressure wash the label or sticker or surfaces near it.
- Do not use strong alkaline soaps on or near the label or sticker.

21.04 Care of Exterior Lights

**NOTICE:**

Do not use a power buffer, paper towels, chemical solvents, or abrasive cleaners on the headlight lens, all of which can remove the UV coating from the surface, and result in yellowing of the lens.

Clean the headlight lenses by hand only, using a flannel cloth with mild, non-caustic soap or detergent, and water.

21.05 Caring for External Chrome Components

NOTE: Chrome components are optional on the M2 Plus.

To prevent rust, keep chrome parts clean and protected at all times. This is especially important during winter driving and in coastal areas where there is exposure to salt air.

When cleaning chrome parts, use clean water and a soft cloth or sponge. A mild detergent may also be used.

Sponge gently, then rinse. If necessary, use a non-abrasive chrome cleaner to remove stubborn rust or other material. Do not use steel wool.

To help protect the chrome after cleaning, apply a coat of polishing wax to the surface. Never use wax on parts that are exposed to high heat, such as exhaust pipes.

21.06 Care of Fiberglass Parts

NOTE: The standard M2 Plus hood is fiberglass.

Wash fiberglass components with a mild detergent, such as dishwashing liquid. Avoid strong alkaline cleansers and bleach. Apply a wax specifically designed for fiberglass.

22.01 Periodic Inspections and Maintenance, General Information.....	394
22.02 Checklists	394
22.02.01 Daily Pretrip Inspection Checklists.....	394
22.02.02 Weekly Post-trip Inspection Checklist	396
22.02.03 Monthly Post-trip Inspection Checklists.....	396
22.03 Fluids Added.....	397

22. Pre- and Post-Trip Checklists

22.01 Periodic Inspections and Maintenance, General Information

It is the driver's responsibility to perform an inspection, and ensure the complete road-worthiness of a vehicle, before placing it into service. Commercial vehicles may be subject to inspection by authorized inspectors, and an unsafe vehicle can be taken "out of service" until the driver or owner repairs it.

Use the following checklists to ensure that vehicle components are in good working condition before each trip. Careful inspections eliminate stops later to fix overlooked or forgotten items.

The checklists in this chapter can be copied and kept as a record that the procedures have been completed. For details on how to inspect each item on the checklists, see the corresponding procedure (step number), see [23.01 Safety Precautions](#).

22.02 Checklists

22.02.01 Daily Pretrip Inspection Checklists

NOTE: Checklists in this chapter correspond with the procedures and steps, see [23.01 Safety Precautions Pre- and Post-Trip Inspections and Maintenance](#). Your vehicle may not be equipped with all components listed below.

See the following tables for a list of procedures that should be performed daily, before the first trip. Place a check mark in the complete (**Comp.**) column to indicate a procedure has been performed.

Inspector	Date

Suspension and Slack Adjusters		Comp.
1	Suspension components	
2	Slack adjusters	

Wheels and Tires		Comp.
1	Wheel covers	
2	Tire condition	
3	Tire inflation	
4	Rims and wheel components	
5	Wheel bearing oil seals and lubrication levels	
6	Mud Flaps	

Saddle Tank Areas		Comp.
1	Drain air reservoirs (without automatic drain valves)	

2	Fuel tank(s) secure	
3	Frame rails and crossmembers	
4	Visible exhaust components	

Engine Compartment		Comp.
1	Leakage under engine	
2	Air intake system	
3	Engine oil level	
4	Power steering reservoir level	
5	Engine coolant level	
6	Visible engine wiring	
7	Frame rails	

Cab		Comp.
1	Reset dash-mounted air intake restriction indicator (if equipped)	
2	Air pressure warning systems	
3	Air governor cut-in and cut-out pressures	
4	Air pressure build-up time	
5	Air system leakage	
6	Air pressure reserve	
7	Mirrors, windows, windshield	
8	Horn, windshield wipers, windshield washers	
9	Heater and defroster	
10	Interior lights	
11	Exterior lights	
12	Seat belts and tether belts	
13	Fuel level	
14	Mirror adjustment	

15	Service brakes	
16	Backup alarm	

22.02.02 Weekly Post-trip Inspection Checklist

See the following table for procedures that should be performed weekly, post-trip. Place a check mark in the complete (**Comp.**) column to indicate a procedure has been performed.

Inspector	Date

Engine Compartment		Comp.
1	Windshield washer reservoir level	
2	Air intake restriction indicator	
3	Water evacuation components	
4	Automatic transmission fluid level	
5	Water in fuel/water separator	
6	Steering components	
7	Serpentine drive belts	

22.02.03 Monthly Post-trip Inspection Checklists

See the following tables for procedures that should be performed monthly, post-trip. Place a check mark in the complete (**Comp.**) column to indicate a procedure has been performed.

Inspector	Date

Brake Components		Comp.
1	Brake system components	
2	Brake chambers	
3	Air brake lines	
4	Flex air hoses	
5	Brake linings and brake drums	
6	Brake lining thickness	

Saddle Tank Areas		Comp.
1	Drain air reservoirs (with automatic drain valves)	
2	Batteries (location may vary)	
3	Aerodynamic components	

Engine Compartment		Comp.
1	Hood and bumper	
2	Hydraulic clutch reservoir	
3	Radiator and heater hoses	
4	Steering wheel play	

22.03 Fluids Added

Use the following table to note any fluids that were added during the inspection and maintenance procedures.

Fluids Added During Inspection	
Fluid	Amount Added
Wheel Bearing Lubricant	
Engine Oil	
Power Steering Fluid	
Engine Coolant	
Windshield Washer Fluid	
Automatic Transmission Fluid	
Hydraulic Clutch Fluid (DOT 4 brake fluid)	

23.01 Safety Precautions	400
23.02 Daily Pretrip Inspections and Maintenance	400
23.02.01 General Information	400
23.02.02 Suspension and Slack Adjuster Inspection	400
23.02.03 Inspection of the Wheel and Tire	402
23.02.04 Inspection of the Saddle Tank Areas	405
23.02.05 Inspection of the Engine Compartment	406
23.02.06 Inspection of the Cab.....	408
23.03 Weekly Post-Trip Inspections and Maintenance	413
23.03.01 Inspection of the Engine Compartment	413
23.04 Monthly Post-Trip Inspections and Maintenance	417
23.04.01 Inspection of the Brake Component.....	417
23.04.02 Inspection of the Saddle Tank Areas.....	418
23.04.03 Inspection and Adjustments of the Engine Compartment.....	419

23. Pre- and Post-Trip Inspections and Maintenance

23.01 Safety Precautions

**DANGER:**

When working on the vehicle, shut down the engine, set the parking brake, and chock the tires. Before working under the vehicle, always place jack stands under the frame rails to ensure the vehicle can not drop. Failure to follow these steps could result in serious personal injury or death.

23.02 Daily Pretrip Inspections and Maintenance

23.02.01 General Information

Complete the following inspection and maintenance procedures to ensure that vehicle components are in good working condition before each trip. A driver who is familiar with the vehicle and drives it regularly can perform the daily inspections, then add the weekly and monthly post-trip inspections as scheduled.

If the driver does not operate the vehicle on a consistent basis, all daily, weekly, and monthly inspection and maintenance procedures should be performed before the trip.

IMPORTANT: The pre- and post-trip checklists, inspections, and maintenance procedures detailed in this chapter are **not all-inclusive**. Refer to other component and body manufacturers' instructions for specific inspection and maintenance instructions, as well as local, state, and federal guidelines.

NOTE: If any system or component does not pass this inspection, it must be corrected before operating the vehicle. Whenever equipment requires adjustment, replacement, and/or repair, see the *108SD and 114SD Workshop Manual* for procedures and specifications.

23.02.02 Suspension and Slack Adjuster Inspection

Walk around the vehicle and visually inspect suspension and slack adjuster components.

1. Inspect the following suspension components for signs of structural damage, cracks, or wear.
 - springs
 - spring hangers
 - shocks
 - suspension arms
 - suspension brackets
 - axle seats
 - bushings
2. Inspect slack adjusters for signs of damage. See Fig.343, [Gunite Automatic Slack Adjuster](#), see Fig. 344, [Haldex Automatic Slack Adjuster](#), or see Fig.345, [Meritor Automatic Slack Adjuster](#).

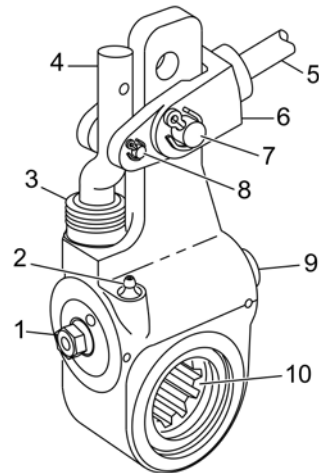

02/03/2017

f421398

- | | |
|-----------------------------|---------------------------|
| 1. 7/16-inch Adjusting Nut | 6. Clevis |
| 2. Grease Fitting | 7. 1/2-inch Clevis Pin |
| 3. Boot | 8. 1/4-inch Clevis Pin |
| 4. Link | 9. Grease Relief Opening |
| 5. Brake Chamber Piston Rod | 10. Slack Adjuster Spline |

Fig 393, Gunite Automatic Slack Adjuster

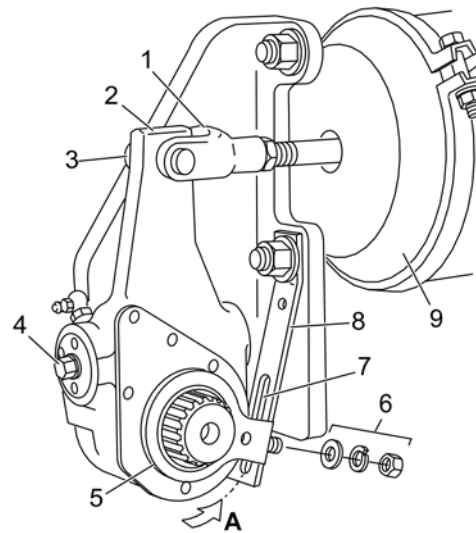

02/03/2017

f421397

- | | |
|--|--------------------------------|
| A. Rotate the control arm toward the brake chamber until you can feel it contacting the internal stop. | 5. Control Arm |
| 1. Clevis | 6. Control-Arm Washers and Nut |
| 2. Slack Adjuster | 7. Anchor Strap Slot |
| 3. Clevis Pin | 8. Anchor Strap |
| 4. Manual Adjusting Nut | 9. Brake Chamber |

Fig 394, Haldex Automatic Slack Adjuster

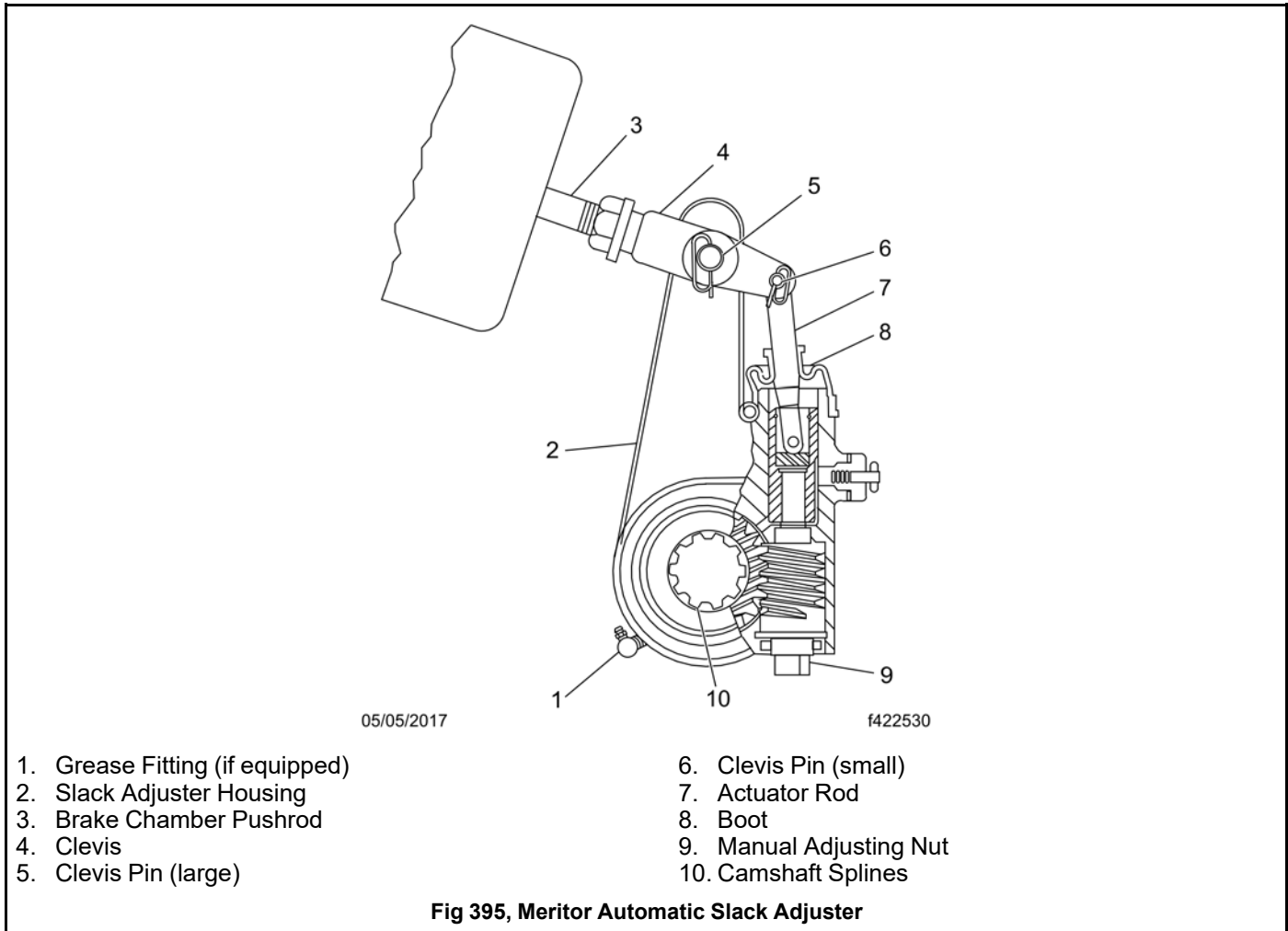

- Inspect slack adjuster boots, if equipped, for cuts or tears.
- Inspect anchor straps, if equipped, for damage.
- Look for worn clevis pins on brake chamber pushrods.
- Look for missing or damaged cotter pins on the clevis pins.
- Ensure chamber piston rods are in line with the slack adjusters.

23.02.03 Inspection of the Wheel and Tire

Walk around the vehicle and visually inspect each wheel and tire assembly.

IMPORTANT: Wheel covers decrease drag force as a vehicle moves, thereby improving fuel efficiency. If replacement of a wheel cover is necessary, the replacement cover must meet or exceed the drag reduction performance of the originally installed cover in order to maintain compliance with greenhouse gas and fuel efficiency regulations.

1. If the vehicle was originally equipped with wheel covers, ensure all wheel covers are present. Inspect wheel covers for damage or wear. Remove wheel covers from rear drive wheels, if equipped, prior to inspecting the tires and wheel components.

NOTE: During wheel cover installation, ensure the V-notch in the liner inner retaining ring is centered on the valve stem. The inner and outer retaining rings should be uniformly aligned to each other and to the wheel rim. The outer retaining ring of the liner is equipped with two canvas flaps. When installing the face cover, make sure the cover retaining ring is inserted between the two canvas flaps on the liner outer retaining ring so that the Velcro strips line up between the face cover and the liner. Make certain the detachable view cover is centered on the face cover, and the Velcro strips are pressed firmly in place.

2. Inspect each tire for the following:

- valve stem caps on every tire, screwed on finger-tight
- bulges, cracks, cuts, and penetrations
- oil contamination (petroleum derivatives will soften the rubber and destroy the tire)
- tread depth—if tread is less than $4/32$ inch (3 mm) on any front tire, or less than $2/32$ inch (1.5 mm) on any rear tire, replace the tire
- debris lodged between dual tire sets

IMPORTANT: Low-rolling resistance (LRR) tires minimize wasted energy as a tire rolls, thereby decreasing rolling effort and improving fuel efficiency. If tire replacement is necessary, replacement tires must meet or have less rolling resistance than the originally installed tires in order to maintain compliance with greenhouse gas and fuel efficiency regulations. Contact your tire manufacturer/supplier to determine the rolling resistance of the originally installed tires. Visit www.epa.gov/smartway for additional information and resources.

3. Check tire inflation.

For inflation pressures and maximum loads, see the tire manufacturer's guidelines. Inflate the tires to the applicable pressures if needed.

If a tire has been run flat or under-inflated, check the wheel and tire for damage before adding air.

Keep compressed air reservoirs and lines dry during tire inflation. Use well-maintained inline moisture traps and service them regularly.

**WARNING:**

Do not operate the vehicle with underinflated or overinflated tires. Incorrect inflation can stress the tires and make the tires and rims more susceptible to damage, possibly leading to rim or tire failure and loss of vehicle control, resulting in serious personal injury or death.

IMPORTANT: The load and cold inflation pressure must not exceed the rim or wheel manufacturer's recommendations, even though the tire may be approved for a higher load inflation. Consult the rim or wheel manufacturer for the correct tire inflation pressure for the vehicle load.

**NOTICE:**

A weekly pressure loss of 4 psi (28 kPa) or more in a tire may indicate damage. The tire should be inspected and, if necessary, repaired or replaced by a qualified tire service facility.

4. Examine each rim and wheel component.
 - 4.a Remove all dirt and debris from the assembly. Rust streaks or metal build-up around stud holes, or out-of-round or worn stud holes, may be caused by loose wheel nuts.

**WARNING:**

Have any worn or damaged wheel components replaced by a qualified person using the wheel manufacturer's instructions and the wheel industry's standard safety precautions and equipment. Otherwise a vehicle or workshop accident could occur, possibly resulting in serious personal injury or death.

- 4.b Inspect for broken, cracked, badly worn, bent, rusty, or sprung rings and rims.

**NOTICE:**

Use the recommended torque values and follow the proper tightening sequence. Insufficient wheel nut torque can cause wheel shimmy, resulting in wheel damage, stud breakage, and extreme tire tread wear. Excessive wheel nut torque can break studs, damage threads, and crack discs in the stud hole area.

- 4.c Make sure all wheel nuts are tightened. If tightening is necessary, use the tightening pattern, see Fig. 346, [Tightening Pattern, 10-Hole Wheels](#) to initially tighten the flange nuts to 50 to 100 lbf·ft (68 to 136 N·m). Then tighten the flange nuts to 450 to 500 lbf·ft (610 to 678 N·m).

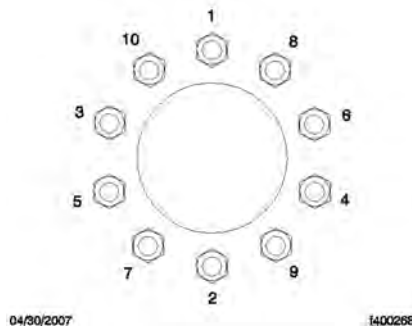

Fig 396, Tightening Pattern, 10-Hole Wheels

5. Inspect the outboard side of all wheel hubs and the hub oil seal area on the inboard side of each wheel for signs of oil leakage. If any oil is found on wheel and tire or brake components, remove the vehicle from service until the leak has been fixed.

If needed, fill the hubs to the level indicated on the hub cap. See **Group 35** of the *M2 Plus Maintenance Manual* for recommended lubricants.

6. Check that mud flaps are undamaged and hang 10 inches (25.4 cm) or less from the ground.

23.02.04 Inspection of the Saddle Tank Areas



WARNING:

When draining the air reservoir, do not look into the air jets or direct them toward anyone. Dirt or sludge particles may be in the airstream and could cause injury.



NOTICE:

If the water drained from the air reservoirs is cloudy or oily, it may indicate a problem with the compressor. If oil is allowed to contaminate the air dryer, it will not remove the water from the air brake system, which could adversely affect braking.

1. Drain the brake system air reservoirs (reservoirs without automatic drain valves only).



WARNING:

Never operate the engine with the fuel tank shutoff valves partially closed. This could damage the fuel pump, causing sudden loss of engine power, possibly resulting in serious personal injury due to reduced vehicle control.

2. Ensure fuel tanks are secured to their mounting brackets and that the mounting brackets are secured to the frame.
3. Inspect visible frame rails for missing bolts, shiny areas, or rust streaks. Check all visible crossmembers for damage or signs of looseness.

4. Inspect visible components of the exhaust system to ensure connections are tight.

Inspect upstream of the aftertreatment device (ATD) for cracking or signs of leaks, such as soot trails. Inspect downstream of the ATD for signs of exhaust leaks, such as blistering or warping of nearby components.

23.02.05 Inspection of the Engine Compartment

1. Check the ground underneath the engine for fuel, oil, or coolant leaks.
2. Inspect the air intake system for leaks or damage.



NOTICE:

Failure to maintain a sealed air intake system could allow the entry of dirt and contaminants into the engine. This could adversely affect engine performance and result in engine damage.

- 2.a Push the reset button on the air intake restriction indicator located on the air cleaner, if equipped.

NOTE: The air intake restriction indicator may be located on the air intake or the dash.

- 2.b Check the engine air intake duct from the air cleaner to the engine intake. Make sure the duct components are secure and airtight.
- 2.c Check the vacuator (spitter) valve(s) for damage, and make sure the lips of the valve are pliable and free of debris.
3. Check the engine oil level.



NOTICE:

Operating the engine with the oil level below the minimum fill (or "add") mark or above the maximum fill (or "full") mark could result in engine damage.

- 3.a Check the oil level with the vehicle parked on a level surface. See the engine manufacturer's guidelines for engine shutdown time requirements prior to checking the oil level.

IMPORTANT: Use only approved engine lube oil. For lists of engine oils approved for Detroit Diesel engines, refer to the Engine Operator Manual, accessible on Lubricants, Fuels & Coolants on the DTNA Portal. For third party engines, please refer to the engine manual.

- 3.b If the oil level is at or below the minimum fill (or "add") mark on the dipstick, add enough oil to maintain the level between the minimum and maximum fill marks. See the engine operation manual for recommended lubricants.
4. Check the power steering reservoir fluid level.

The power steering fluid level should be between the MIN COLD mark and the middle mark just above it. See Fig. 347, [Power Steering Fluid Reservoir](#). If needed, fill the reservoir with automatic transmission fluid that meets Dexron III or TES-389 specifications.

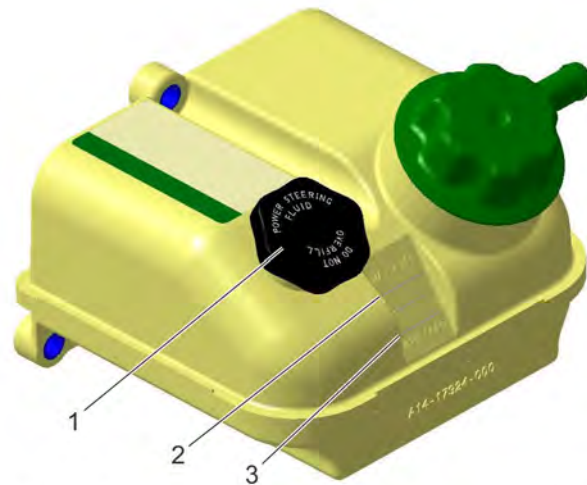

04/30/2020

f462252a

NOTE: Typical reservoir shown; configurations may vary.

1. Filler Cap
2. MAX Fill Line

3. COLD MIN Fill Line

Fig 397, Power Steering Fluid Reservoir

IMPORTANT: The surge tank must be cool to check the coolant level.

**NOTICE:**

Low coolant could result in engine overheating, which could cause engine damage.

5. Check the engine coolant level in the radiator surge tank. See Fig.348, [Coolant Surge Tank](#).

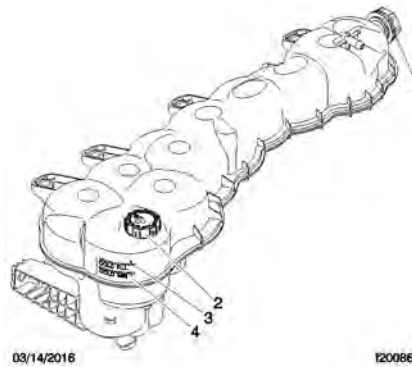

1. Pressure Relief Cap
2. Filler Cap

3. COLD MAX Fill Line
4. COLD MIN Fill Line

Fig 398, Coolant Surge Tank



NOTICE:

Coolant must be filled to the COLD MAX line of the surge tank. Low coolant could result in engine overheating, which could cause engine damage.

- 5.a If the coolant is low, fill the surge tank to the MAX line with a 50/50 mixture of water and the type of anti-freeze currently installed in your vehicle.
- 5.b If the surge tank was empty, start the engine after refilling and check the level again when the engine is at operating temperature.
6. Inspect visible engine wiring for damage or looseness. Check for loose wiring, chafed insulation, and damaged or loose hold-down clamps.
7. Inspect visible frame rails for missing bolts, shiny areas, or rust streaks.

23.02.06 Inspection of the Cab

1. Push the reset button on the dash-mounted air intake restriction indicator, if equipped.
2. With the ignition switch in the OFF position, check the air-pressure warning system.

NOTE: The low-air warning buzzer only works when the park brake is released. The low-air warning buzzer is silenced when the park brake is set.

- 2.a If not previously drained, drain the air reservoirs using moderate brake applications until pressure in both reservoirs is less than 70 psi (483 kPa).
- 2.b Turn the ignition to the ON position. The ICU will complete a full gauge sweep and bulb check, and the warning buzzer will sound. Ensure the BRAKE AIR lamp remains illuminated and the warning buzzer continues to sound after the gauge sweep is complete.
3. Check air governor cut-in and cut-out pressures.
 - 3.a Start the engine and ensure the BRAKE AIR lamp goes out and the buzzer silences when pressure reaches approximately 70 psi (483 kPa) in both air reservoirs.

The air governor should cut out at approximately 120 psi (827 kPa). For vehicles with an optional dryer reservoir module (DRM), the cut-out pressure is approximately 130 psi (896 kPa).

- 3.b With the engine idling, apply the brake pedal several times. The air governor should cut in when pressure in the primary air reservoir (top air gauge) reaches approximately 100 psi (689 kPa).
4. Check air pressure build-up time.
 - 4.a With the air system fully charged, make one full brake application and note the air pressure reading on the primary air gauge.
 - 4.b Further reduce air pressure using moderate brake applications, then run the engine at governed rpm.
 - 4.c Note the time that the pressure reaches the previously noted reading on the primary air gauge, then note the time that the air pressure reaches cut-out pressure.
 - 4.d If it takes longer than 30 seconds to reach cut-out pressure after the primary air gauge passes the previously noted pressure (noted after one full brake application), eliminate any leaks or replace the air compressor before operating the vehicle.
5. Check air leakage in the system.
 - 5.a With the parking brake applied, the transmission out of gear, and the air system fully charged, release the service brakes and shut down the engine.
 - 5.b Wait one minute and note the air pressure drop in psi (kPa) per minute from the primary air reservoir.
If the pressure drop exceeds the limits shown in Table.42, [Maximum Allowable Air Leakage](#), eliminate any leaks before operating the vehicle.
6. Check the air pressure reserve.

With the engine still off, make one full brake application and observe the pressure drop on the primary air gauge. If pressure drops more than 25 psi (172 kPa), eliminate any leaks before operating the vehicle.

Maximum Allowable Air Leakage		
Description	Pressure Drop: psi (kPa) Per Minute	
	Released	Applied
Truck or Tractor Only	2 (14)	3 (21)
Truck or Tractor w/Single Trailer	3 (21)	4 (28)

Table 34, Maximum Allowable Air Leakage



WARNING:

When cleaning windshields and windows, always stand on the ground or on a secure ladder or platform. Use a long-handled window cleaner. Do not use the cab steps, tires, fenders, fuel tanks, engine, or under-hood components to access the windshield or windows. Doing so could cause a fall and result in an injury.

7. Inspect the mirrors, window glass, and windshield for cracks or other damage.
8. Ensure that the horn, windshield wipers, and windshield washers are operating properly. These devices must be in good working order for safe vehicle operation.

9. Ensure the heater and defroster are operating properly.
10. Check the operation of all interior lights.
 - 10.a Turn on the headlights and leave them on. If equipped, ensure all gauge bulbs illuminate. If equipped, ensure ICU screens illuminate.
 - 10.b Ensure all equipped driver control switches illuminate and verify the interior cab lights controlled by some of these switches illuminate.
 - 10.c Ensure both turn signal indicators illuminate when the turn signal switch is activated.
11. Check the operation of all exterior lamps manually or, if equipped, by using either the LIGHT TEST switch on the dash or the Lamp Check button on the key fob.

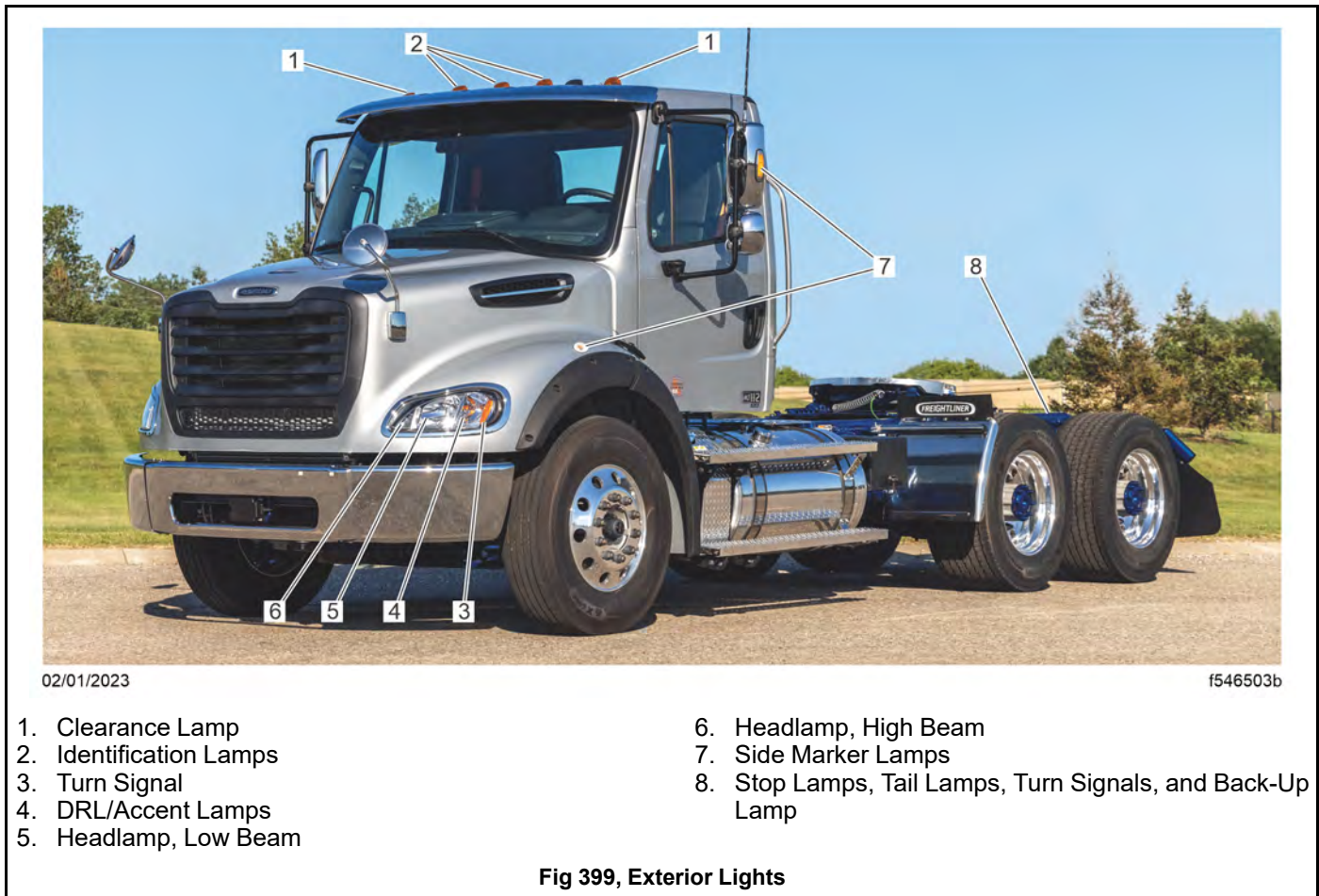

12. To check exterior lamps manually:
 - 12.a Turn the ignition switch to the ACC or ON position.
 - 12.b Make certain the parking brake is set.
 - 12.c Activate the high-beam headlamps and hazard warning lamps.
 - 12.d Exit the cab and check that all exterior lamps and reflectors are clean and intact.
 - 12.e Check that the brake lamps, tail lamps, headlamps, turn signals, marker lamps, identification lamps, and clearance lamps are working properly.

13. To check the exterior lamps using the dash LIGHT TEST switch, shown in 349, [Exterior Lights](#) for key fob Lamp Check button, shown in Fig.351, [Key Fob](#).

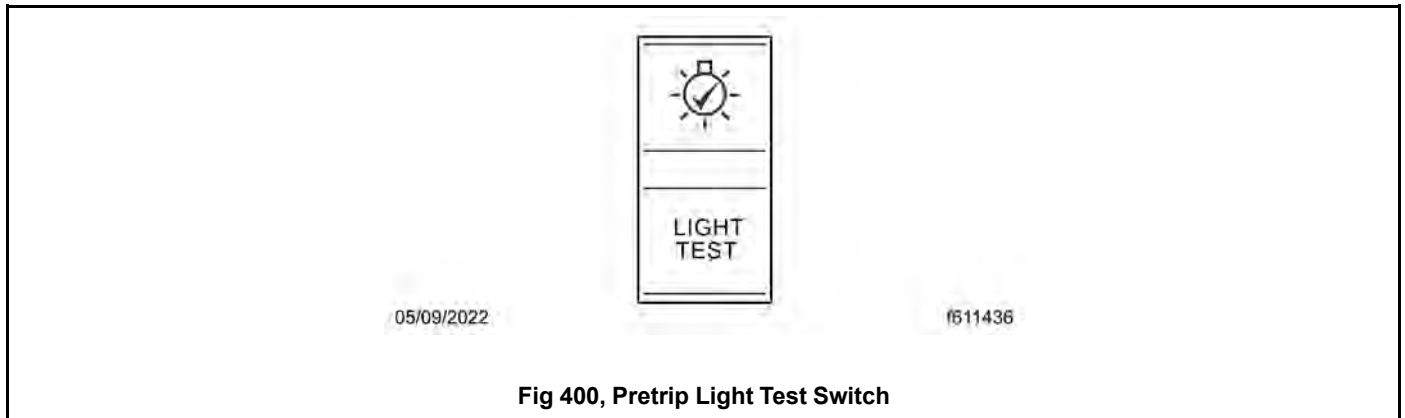

- 13.a Make sure the parking brake is set.

NOTE: Factory settings have groups of lamps activate sequentially up to 100 times or until manually stopped.

- 13.b Press the LIGHT TEST switch to begin the pretrip light inspection. If equipped, groups of lamps will cycle on and off in the following sequence:

- Group 1: Always ON: marker lamps, clearance lamps, tail lamps, licence plate lamp
- Group 2: Low beam headlamps
- Group 3: High beam headlamps and stop lamps
- Group 4: Backup lamps and daytime running lamps
- Group 5: Front and rear fog lamps
- Group 6: Turn signals and utility lamps

NOTE: LED accent lighting turns off when the high beam headlamps turn on.

- 13.c Walk around the truck and check that the lamps are working properly.
- 13.d Verify that all exterior lights and reflectors are clean and intact.
- 13.e The pretrip light inspection can be stopped by:
- releasing the parking brake;
 - Pressing either the LIGHT TEST switch on the dash or the Lamp Check button on the key fob.
14. Inspect the seat belts and tether belts.

**WARNING:**

Inspect and maintain seat belts. When any part of a seat belt system needs replacement, the entire seat belt must be replaced, both retractor and buckle side. Any time a vehicle is involved in an accident, and the seat belt system was in use, the entire vehicle seat belt system must be replaced before operating the vehicle. Do not attempt to modify the seat belt system; doing so could change the effectiveness of the system. Failure to replace worn or damaged seat belts, or making any modifications to the system, may result in personal injury or death.

- 14.a Check the web for fraying, cuts, extreme dirt and dust, or for severe fading from exposure to sunlight, especially near the buckle latch plate and in the D-loop guide area.
- 14.b Check operation of the buckle, latch, Komfort Latch or Sliding Komfort Latch (if equipped), web retractor, and upper seat belt mount on the door pillar. Check all visible components for wear or damage.
- 14.c Check the seat belt and tether belt connection points and tighten any that are loose.

**WARNING:**

Never fill fuel tanks to more than 95 percent of their liquid capacity. This could make them more likely to rupture from impact, possibly causing fire and resulting in serious personal injury or death by burning.

Do not mix gasoline or alcohol with diesel fuel. This mixture could cause an explosion, possibly resulting in serious personal injury or death. Do not fill the fuel tanks in the presence of sparks, open flames, or intense heat. These could ignite the fuel, possibly causing severe burns.

IMPORTANT: Use ultralow-sulfur diesel (ULSD) with 15 ppm sulfur content or less. Failure to use ULSD fuel may void the warranty on emission components.

15. Check the fuel level in the fuel tank(s). To keep condensation to a minimum, fuel tanks should be filled at the end of each day.
16. Adjust the rearview and down view mirrors as necessary.
17. Test the service brakes.
 - 17.a With the engine running and air system fully charged, set the parking brake.
 - 17.b Put the vehicle in the lowest gear and gently attempt to move it forward. The vehicle should not move.
If the vehicle moves, the parking brakes are not operating correctly and must be repaired before the vehicle is operated.
18. Test the backup alarm.
 - 18.a Release the parking brake and put the transmission in reverse.
 - 18.b Move the vehicle slightly backward to ensure that the backup alarm is operating correctly.

23.03 Weekly Post-Trip Inspections and Maintenance

23.03.01 Inspection of the Engine Compartment

**WARNING:**

Washer fluids may be flammable and poisonous. Do not expose washer fluid to an open flame or any burning material, such as a cigarette. Always comply with the washer fluid manufacturer's recommended safety precautions.

1. Check the windshield washer reservoir fluid level. The reservoir is usually located near the right-hand frame rail. See Fig.352, [Windshield Washer Reservoir](#).



04/30/2020

f820442

- 1. Washer Fluid Filler Cap

Fig 402, Windshield Washer Reservoir

- 2. After resetting the air intake restriction indicator during the daily pretrip inspection, check the indicator again with the engine off.
 - 2.a Check an indicator with graduations to see if air restriction exceeds the value shown in Table.43, [Air Intake Maximum Restriction Values](#).
Check a go/no-go indicator without graduations to see if the colored bar shows through the clear window.

Air Intake Maximum Restriction Values (in H2O)	
Engine Make	GHG14, GHG17, and GHG21 Engines
Cummins	25
Detroit	18

Table 35, Air Intake Maximum Restriction Values

- 2.b If air restriction exceeds the maximum allowable value, operate the vehicle for one more day, making sure not to run the engine over rated rpm. Refer to the engine operation manual for more information on rated rpm for your engine.
- 2.c If air restriction exceeds the maximum value again, replace the air cleaner. For instructions, refer to **Group 09** of the *M2 Plus Workshop Manual*.
- 3. Inspect water evacuation components.
 - 3.a Inspect the vacuator valve(s) installed on the hood interior and air cleaner. Make sure the lips of each valve are undamaged and pliable, free of debris, and remain closed during inspection. See Fig. 353, [Hood Vacuator Valves \(hood interior shown\)](#).
 - 3.b Inspect the rain tray installed at the base of the windshield. Ensure that the seal on the forward edge of the rain tray is in good condition.

- 3.c Inspect the drain hoses installed on the rain tray. Both hoses should be securely attached to the rain tray and direct water down the aft side of the front fenders.

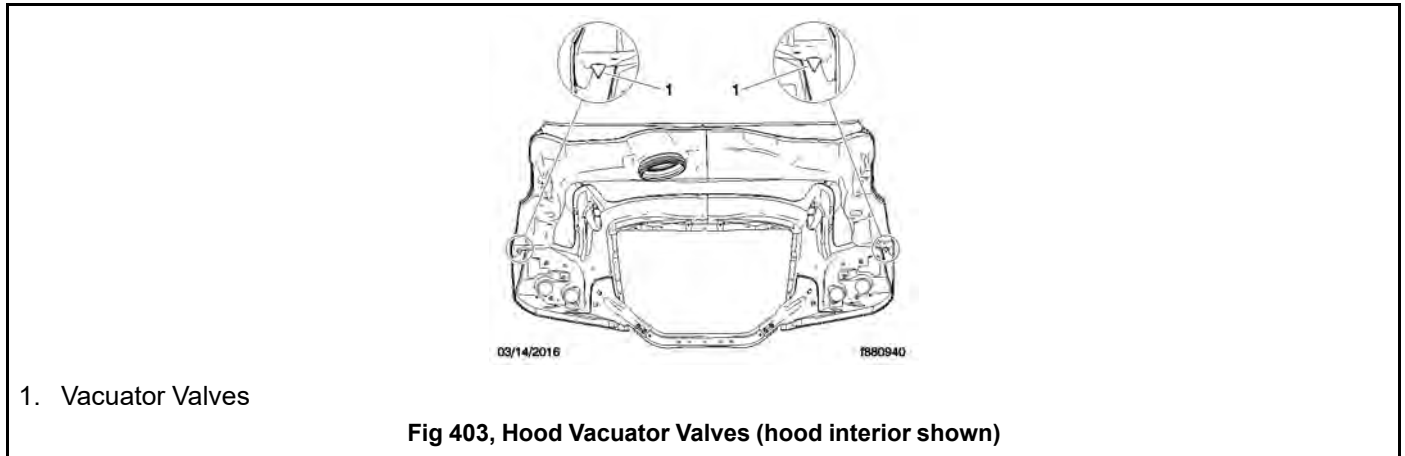

4. If the vehicle is equipped with an automatic transmission, examine the dipstick to check the automatic transmission fluid level.
5. Check for water in the fuel/water separator, if equipped.

IMPORTANT: When draining fluid from a fuel/water separator, drain the fluid into an appropriate container and dispose of it properly. Many jurisdictions now issue fines for draining fuel/water separators onto the ground.

- 5.a Place a suitable container under the fuel/water separator.

NOTE: A hose may be used to direct water into the container. On older DAVCO models, the drain valve has a 1/2-inch (12.7-mm) pipe with threads. Use a hose with a 1/2-inch pipe thread to fit correctly and open the drain valve by turning it one-quarter revolution. On new DAVCO models, the drain valve has a 3/4-inch (19-mm) slip-on hose connection; pipe threads are no longer used. Open the drain valve by turning it one to one-and-a-half revolutions.

- 5.b If the engine is equipped with a built-in water separator, loosen the drain valve, and allow the water to run out. Close the drain valve, taking care not to overtighten it.
- 5.c *Detroit/Racor Models* : Turn the drain plug counterclockwise to open it.

DAVCO Models : Remove the vent cap and open the drain. See Fig.354, [DAVCO Fuel Pro 485](#).

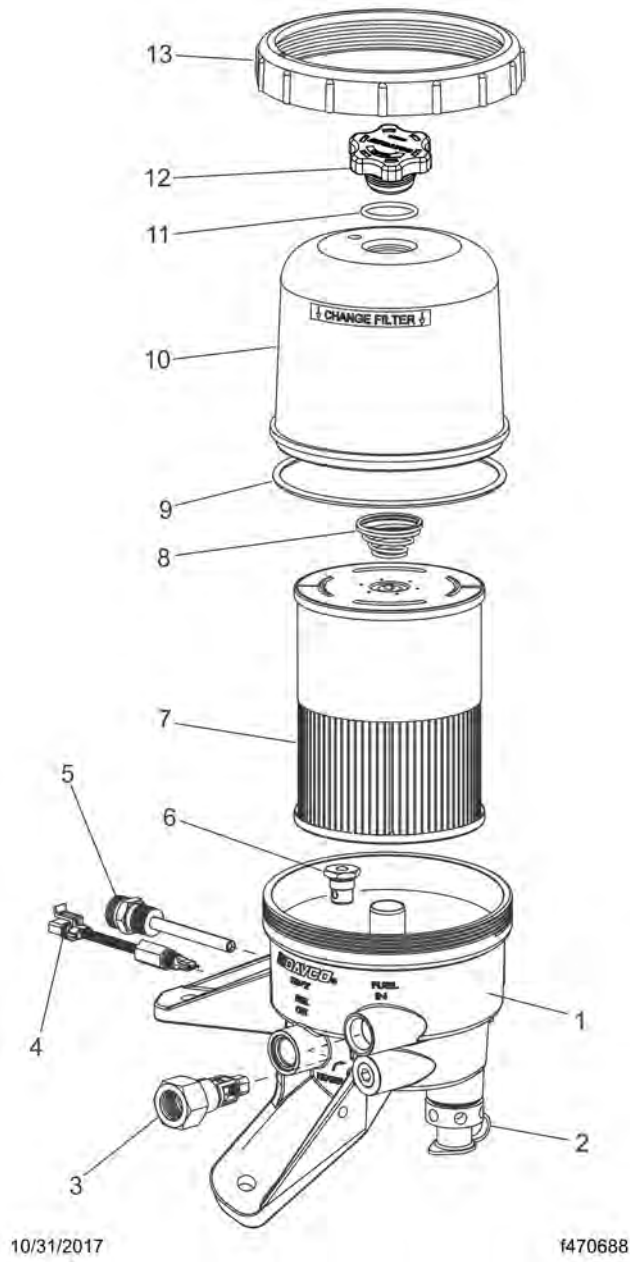

- | | |
|---------------------------|---------------------|
| 1. Lower Housing | 8. Spring |
| 2. Drain Valve | 9. Cover O-Ring |
| 3. Inlet Port/Check Valve | 10. Clear Cover |
| 4. 12VDC Pre-Heater | 11. Vent Cap O-Ring |
| 5. 120VAC Pre-Heater | 12. Vent Cap |
| 6. Bypass Valve | 13. Collar |
| 7. Filter Element | |

Fig 404, DAVCO Fuel Pro 485

5.d Stop draining fluid when fuel begins to drain out.

Detroit/Racor Models : turn the drain plug clockwise to close it.

DAVCO Models : close the drain valve. Install and hand-tighten the vent cap.

6. Inspect the steering components.
 - 6.a Inspect tie rods, steering arms, and the drag link for signs of looseness (i.e., shiny spots or rust tracks).
 - 6.b Check the steering gear mounting bolts and pitman arm nut, if equipped, for signs of looseness. See Fig. 355, [Steering Gear Fasteners](#).
 - 6.c Check the drag link nuts for missing cotter pins.

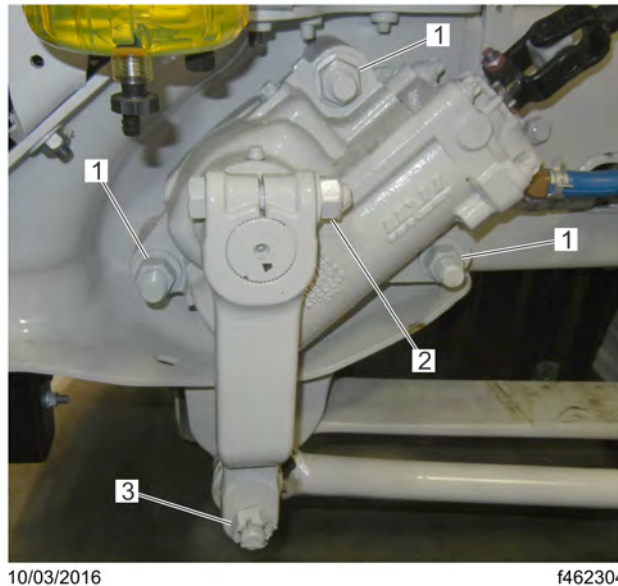

1. Steering Gear Mounting Bolts
2. Pitman Arm Pinch Bolt Nut
3. Drag Link Nut

Fig 405, Steering Gear Fasteners

- 6.d Inspect the steering intermediate shaft and end yokes for excessive looseness or other damage.



NOTICE:

Do not drive with a drive belt that is visibly worn or damaged. If it fails, the lack of coolant flow could rapidly cause damage to engine components.

7. Inspect the serpentine drive belts for signs of glazing, frayed edges, breaks, cracks, or oil contamination.

23.04 Monthly Post-Trip Inspections and Maintenance

23.04.01 Inspection of the Brake Component

Walk around the vehicle and visually the brake system components for visible damage.

NOTE: Some vehicles may be equipped with a brake check valve on the dash, which allows the driver to set the service brakes and exit the vehicle to check the brake system for leaks. The parking brakes must be applied before the brake check valve will function.

1. Inspect all visible brake system components for missing fasteners or signs of looseness, such as rust tracks.

**NOTICE:**

If the external breather tube or breather cap is missing or incorrectly installed, road dirt and debris can adversely affect the operation of the brake chamber. Once inside of the chamber, dirt and debris can cause the internal parts of the chamber to deteriorate faster.

2. Inspect the exterior surfaces of brake chambers for damage. Make sure that breather holes are open and free of debris.

NOTE: Do not route air brake lines on top of anything likely to be stepped on.

3. Inspect air brake lines for dents, swelling, kinks, twisting, abrasion, and damage, especially near moving parts.
4. Inspect flex air lines for deterioration or signs of abrasion.
5. Inspect for cracked, worn, or oil-contaminated brake linings and brake drums (or rotors).
6. Check the thickness of the brake linings. Replace brake linings on all brake assemblies on the axle if any brake linings are worn to less than approximately 1/4 inch (6.4 mm) at the thinnest point.

23.04.02 Inspection of the Saddle Tank Areas

**WARNING:**

When draining the air reservoir, do not look into the air jets or direct them toward anyone. Dirt or sludge particles may be in the airstream and could cause injury.

**NOTICE:**

If the water drained from the air reservoirs is cloudy or oily, it may indicate a problem with the compressor. If oil is allowed to contaminate the air dryer, it will not remove the water from the air brake system, which could adversely affect braking.

1. Drain the brake system air reservoirs (reservoirs with automatic drain valves only).

NOTE: Battery locations vary between vehicles.

2. Inspect the batteries.



WARNING:

Battery posts, terminals, and related accessories contain lead and lead compounds, chemicals known to the State of California to cause cancer and reproductive harm. To prevent possible personal injury, always wash your hands after handling battery parts and related accessories.

- 2.a Remove the battery box cover and inspect all visible battery cables for loose wiring or damage.
- 2.b Check that the battery hold-down is secure.

IMPORTANT: Aerodynamic components decrease drag force as a vehicle moves, thereby improving fuel efficiency. If replacement of an aerodynamic component is necessary, replacement components must meet or exceed the drag reduction performance of the originally installed component in order to maintain compliance with greenhouse gas and fuel efficiency regulations.

3. Inspect the following aerodynamic components, if equipped, for structural damage, cracks, or wear.
 - Chassis fairings
 - Roof fairing/deflector
 - Side skirts
 - Cab/sleeper extenders
 - Battery access cover

23.04.03 Inspection and Adjustments of the Engine Compartment

IMPORTANT: If replacement of the hood or bumper is necessary, the replacement component must meet or exceed the drag reduction performance of the originally installed item in order to maintain compliance with greenhouse gas and fuel efficiency regulations.

NOTE: Anytime a hood is adjusted, removed, or reinstalled, the headlamp aim should be checked.

1. Inspect the bumper and hood for structural damage, cracks, or wear.
2. Check the hydraulic clutch reservoir, if equipped. If necessary, add DOT 4 brake fluid.
3. Inspect the radiator and heater hoses, including the clamps and support brackets.
 - 3.a Inspect the radiator and charge air cooler for damage and accumulated debris. Straighten bent or damaged fins to permit airflow across all areas of the cores.

NOTE: When traveling through areas of high insect concentration, it may be necessary to clean the exterior of the radiator or the charge air cooler core as often as every 200 miles (320 km).

- 3.b Make sure the radiator inlet and outlet hoses are pliable and are not cracking or ballooning.

- 3.c Make sure the heater hoses are pliable and are not cracking or ballooning.
- 3.d Tighten hose clamps as necessary.

IMPORTANT: Do not overtighten hose clamps, as hose life can be adversely affected.

- 3.a Ensure hose support brackets are securely fastened. Make sure hoses are not located near sources of wear, abrasion, or high heat.

IMPORTANT: When replacing hoses, install service-type knitted or braided yarn-reinforced neoprene hose. Extended-service-life silicone hoses may also be used. See the Alliance Parts Catalog at www.alliancebrandparts.com or contact your Freightliner Dealer.

- 4. Check the steering wheel for excessive play.
 - 4.a Start the engine. With the front tires straight ahead, turn the steering wheel until motion is observed at the front wheels.
 - 4.b Align a reference mark on the steering wheel to a rule, then slowly turn the steering wheel in the opposite direction until motion is again detected at the wheels.
 - 4.c Measure the lash (free play) at the rim of the steering wheel. Excessive lash exists if steering wheel movement exceeds 2-1/4 inches (57 mm) with an 18-inch (450-mm) steering wheel.
 - 4.d If there is excessive lash, check the steering system for wear or incorrect adjustment before operating the vehicle.

24.01 Hazard Warning Lights	422
24.02 Fire Extinguisher	422
24.03 Fire in the Cab	422
24.04 Emergency Kit, Optional	422
24.05 Emergency Filter Replacement, Davco	423
24.06 Emergency Starting With Jumper Cables	425
24.07 Raising and Lowering a Vehicle	427
24.07.01 Raising a Vehicle with Air Suspension	427
24.07.02 Lowering a Vehicle with Air Suspension	428
24.07.03 Raising a Vehicle without Air Suspension	428
24.07.04 Lowering a Vehicle without Air Suspension	429
24.08 Front Towing Hookup With Removable Tow Hooks	429
24.08.01 General Information	429
24.08.02 Use of Tow Hooks	430

24. In an Emergency

24.01 Hazard Warning Lights

The hazard warning light switch is located on the dash in what is referred to as the master module. See Fig. 356, [Hazard Warning Switch](#). The hazard lights can be activated regardless of the ignition switch position.

To activate the hazard lights, push the center of the switch once. The switch will blink at the same rate that the hazard lights flash. Push the switch again to turn them off. All the turn signal lights on the vehicle and trailer, as well as the turn signal indicators in the ICU, flash simultaneously when the hazard lights are activated.



Fig 406, Hazard Warning Switch

24.02 Fire Extinguisher

A fire extinguisher is located in the cab by the driver's door.

24.03 Fire in the Cab

The incidence of fire in heavy and medium-duty trucks is rare, according to data from the National Highway Traffic Safety Administration. Federal Motor Vehicle Safety Standard #302 limits the flammability of specified materials used inside the cab but, despite this, most materials can burn.



WARNING:

Do not allow flames, sparks, or any other heat sources (such as cigarettes or light bulbs) to contact materials in the cab. Any materials in the cab in contact with such heat sources could cause serious personal injury as well as damage to the vehicle.

In Case of a Cab Fire

As quickly as possible, bring the vehicle to a safe stop, apply the parking brake, turn off the ignition, and get out of the vehicle.

24.04 Emergency Kit, Optional

An optional emergency kit is located in the cab. The kit includes one or more of the following: a first aid kit, a reflective vest, a triangular reflector, a flare kit, and (on vehicles with a Davco fuel/water separator) a spin-on fuel filter element.

If there is an emergency while driving, cautiously pull off the road. Turn on the hazard warning lights. Place the flares and reflector along the side of the road to alert other drivers that an emergency situation exists.

**WARNING:**

Use extreme care when placing flares in emergency situations that involve exposure to flammable substances such as fuel. An explosion or fire could occur causing serious personal injury.

24.05 Emergency Filter Replacement, Davco

If the filter cover on the Davco fuel/water separator is broken, it will not be possible to operate the vehicle. A standard spin-on filter will correct this problem.

Refer to the Davco web site for additional information, www.davcotec.com.

To replace the filter on all Davco fuel/water separators, follow these procedures:

1. Drain the fuel into a suitable container until it is below the level of the filter collar. See Fig. 357, [Davco Model 382 Fuel/Water Separator](#) for the model 382 fuel/water separator.

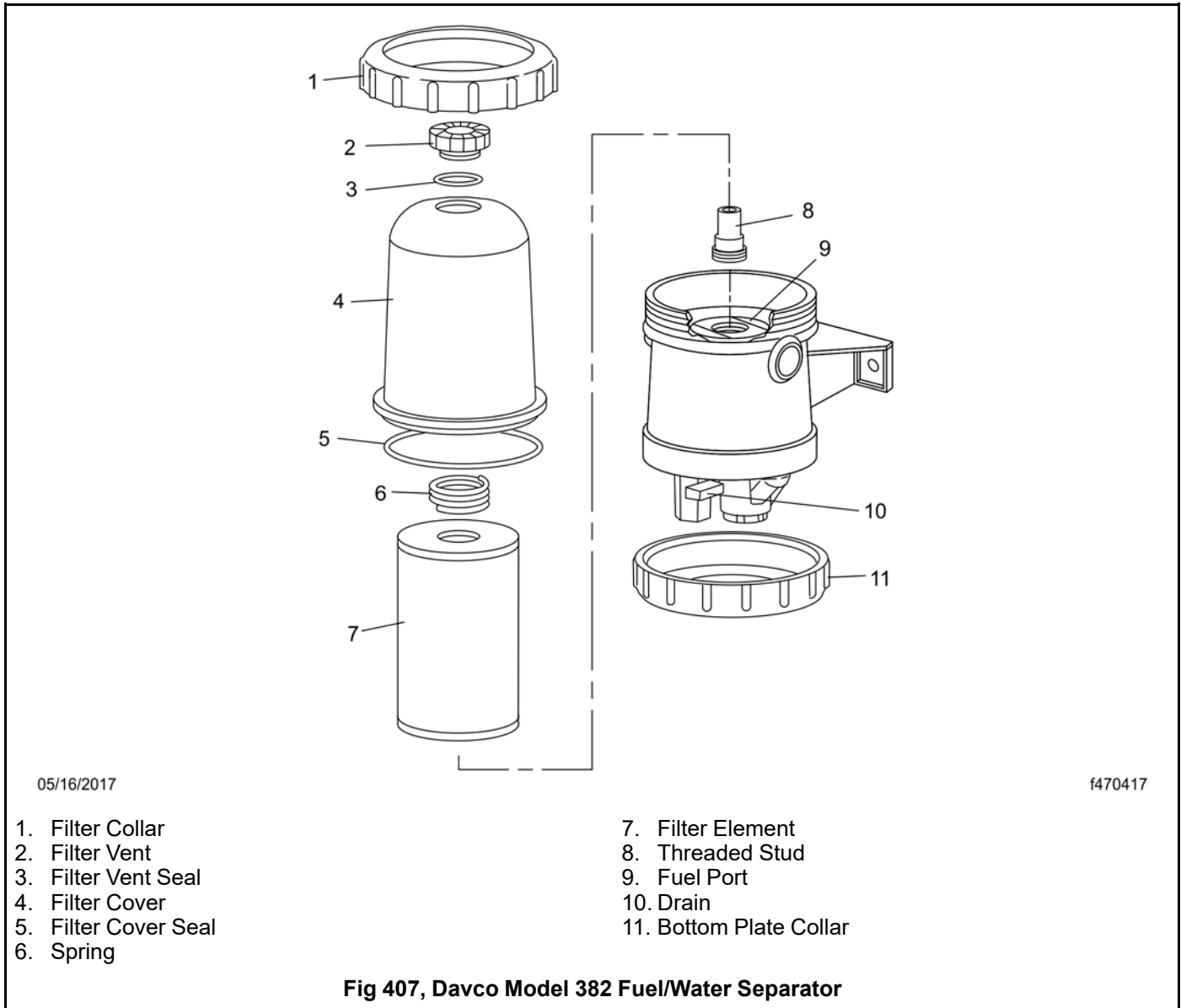

- 1. Filter Collar
- 2. Filter Vent
- 3. Filter Vent Seal
- 4. Filter Cover
- 5. Filter Cover Seal
- 6. Spring

- 7. Filter Element
- 8. Threaded Stud
- 9. Fuel Port
- 10. Drain
- 11. Bottom Plate Collar

Fig 407, Davco Model 382 Fuel/Water Separator

2. Remove the filter vent and vent seal.

NOTE: The filter vent and vent seal are not needed in the emergency replacement. They should be retained for later installation at the time when the filter cover is replaced.

3. Using a DAVCO collar wrench, shown in Fig.358, [DAVCO Collar Wrench](#), remove the clear cover and collar.

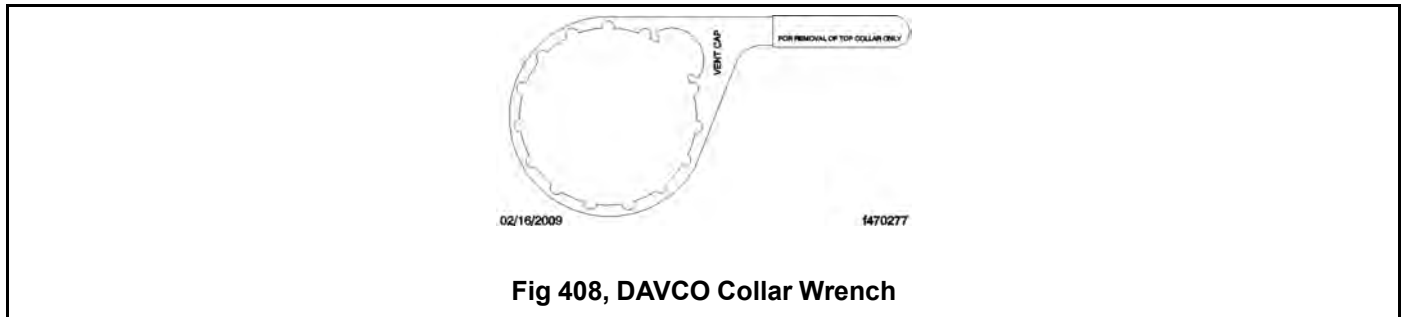

NOTE: Broken vent cap and collar warranty claims will not be accepted if any tool other than a DAVCO collar wrench, p/n 380134 or 382002, is used for removal. During installation, the vent cap is to be **hand-tightened only**, not tightened with a wrench.

4. Remove the filter cover, filter cover seal and spring. Retain them for later assembly.
5. Remove the filter element and dispose of it properly.

NOTE: Remove the rubber grommet from the stud.

6. Install the standard engine spin-on filter (included in the emergency kit) on the threaded stud.
7. Install the filter cover, filter cover seal, and spring, as removed.
8. Install the filter collar over the filter cover. Simultaneously apply downward pressure to the top of the clear cover until it is seated on the body of the lower housing and hand tighten the collar until it no longer spins freely. Using the collar wrench, tighten the cover 18 lbf·ft (24 N·m). This is equivalent to rotating the collar clockwise two or three additional ribs, depending on the specific filter model.
9. Start the engine and run it at increased rpm for one minute to purge air from the fuel lines.

24.06 Emergency Starting With Jumper Cables

When using jumper cables, follow the instructions below.



WARNING:

Batteries release explosive gas. Do not smoke when working around batteries. Put out all flames and remove all sources of sparks or intense heat in the vicinity of the battery. Do not allow the vehicles to touch each other. Do not lean over the batteries when making connections, and keep all other persons away from the batteries. Failure to follow these precautions could lead to severe personal injury as a result of an explosion or acid burns.



NOTICE:

Make sure both electrical systems are the same voltage. Electronic devices on both vehicles can be damaged when connected to a vehicle with a different operating voltage.

NOTE: On vehicles equipped with optional underhood jump start posts, connect to these posts instead of the batteries.

1. Apply the parking brakes and turn off the lights and all other electrical devices.
2. Remove the battery box cover.

NOTE: The battery box on an M2 Plus may be located in a variety of locations, including under the passenger seat, behind the side fairing, or behind the cab. If the battery box is located behind the side fairing, it can be accessed by opening the side fairing kick panel.

3. Connect the positive (+) jumper cable to the positive battery post or jump start post on the vehicle needing the jump start. See Fig.359, [Jumper Connections on Vehicle Needing Jump Start](#), ref. A.

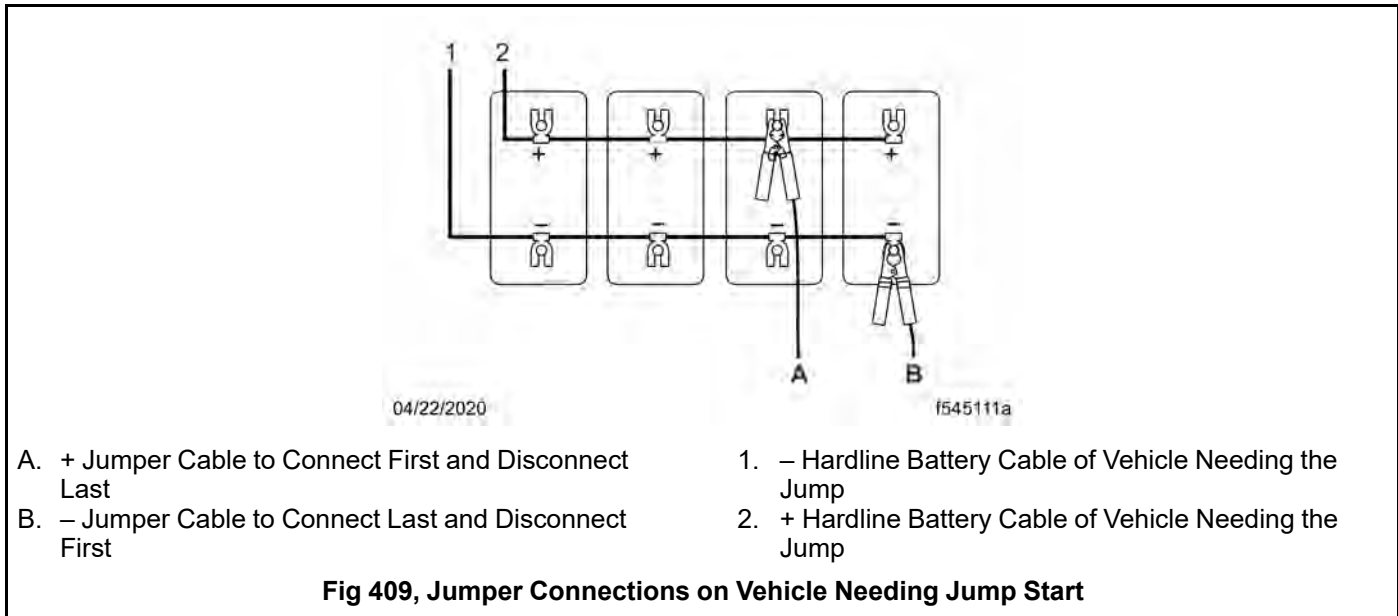

4. Then connect the other end of the positive jumper cable to the positive battery or jump start post of the vehicle providing the jump start.



WARNING:

Do the next step exactly as instructed and do not allow the clamps of one cable to touch the clamps of the other cable. Otherwise, a spark could occur near a battery, possibly resulting in severe personal injury from explosion or acid burns.

5. Connect one end of the negative jumper cable to the negative battery or jump start post of the vehicle providing the jump start.
6. Then connect (ground) the other end of the cable to a negative battery or jump start post on the vehicle needing a jump start. See Fig.359, [Jumper Connections on Vehicle Needing Jump Start](#), ref. B.
7. Start the engine of the vehicle providing the jump start and let the engine run a few minutes to charge the batteries of the other vehicle.
8. Attempt to start the engine of the vehicle with the batteries receiving the charge. Do not operate the starter longer than 30 seconds, and wait at least two minutes between starting attempts to allow the starter to cool.
9. When the engine starts, let it idle a few minutes.

**WARNING:**

Do the next step exactly as instructed and do not allow the clamps of one cable to touch the clamps of the other cable. Otherwise, a spark could occur near a battery, possibly resulting in severe personal injury from explosion or acid burns.

10. Disconnect the negative (grounded) jumper cable from the vehicle that needed the jump start. See Fig. 359, [Jumper Connections on Vehicle Needing Jump Start](#), ref. B.
11. Then disconnect the other end of the jumper cable from the vehicle that provided the jump start.
12. Disconnect the positive jumper cable from the positive battery or jump start post of the vehicle that provided the jump start.
13. Then disconnect the other end of the positive jumper cable from the positive battery or jump start post of the vehicle that received the jump start. See Fig. 359, [Jumper Connections on Vehicle Needing Jump Start](#), ref. A.
14. Install the battery box cover; be sure it is positioned properly before fastening the latches.

24.07 Raising and Lowering a Vehicle

24.07.01 Raising a Vehicle with Air Suspension

1. Park the vehicle on a level surface, set the parking brakes, and shut down the engine. Chock the tires.

**WARNING:**

Remove the air from the suspension. Failure to remove the air from the suspension may cause the vehicle to move or shift on the jack stands as air pressure drains from the system; this could cause the vehicle to fall, resulting in damage to the vehicle, serious injury, or death.

2. Exhaust all air from the air suspension.

**WARNING:**

Do not use bottle jacks to raise the vehicle. Always use floor jacks. Bottle jacks can slip, allowing the vehicle to fall, which could result in damage to the vehicle, serious injury, or death.

IMPORTANT: Only lift unloaded vehicles and vehicles disconnected from trailers. Unload vehicles with bodies (drilling rigs, mixers) as much as possible.

3. Place a floor jack under the axle housing, the clamp group, or the frame rail.

**NOTICE:**

Do not place jack stands under any of the suspension components; doing so could cause suspension component damage. Jack stands can be placed at any point below the axle, including the differential area.

4. Raise the vehicle. Add additional jack stands, as needed, under the axles to support the vehicle.

24.07.02 Lowering a Vehicle with Air Suspension

**WARNING:**

Do not use bottle jacks to raise the vehicle. Always use floor jacks. Bottle jacks can slip, allowing the vehicle to fall, which could result in damage to the vehicle, serious injury, or death.

**NOTICE:**

Do not place jack stands under any of the suspension components; doing so could cause suspension component damage. Jack stands can be placed at any point below the axle, including the differential area.

1. Using the floor jack, raise the vehicle to remove any jack stands used to support the vehicle.
2. Slowly lower the vehicle to the ground.
3. Inflate the air suspension, and check for proper operation.

24.07.03 Raising a Vehicle without Air Suspension

1. Park the vehicle on a level surface, set the parking brakes, and shut down the engine. Chock the tires.

**WARNING:**

Do not use bottle jacks to raise the vehicle. Always use floor jacks. Bottle jacks can slip, allowing the vehicle to fall, which could result in damage to the vehicle, serious injury, or death.

IMPORTANT: Only lift unloaded vehicles and vehicles disconnected from trailers. Unload vehicles with bodies (drilling rigs, mixers) as much as possible.

2. Place a floor jack under the axle housing, the clamp group, or the frame rail.

**NOTICE:**

Do not place jack stands under any of the suspension components; doing so could cause suspension component damage. Jack stands can be placed at any point below the axle, including the differential area.

3. Raise the vehicle. Add additional jack stands, as needed, to support the vehicle.

24.07.04 Lowering a Vehicle without Air Suspension

**WARNING:**

Do not use bottle jacks to raise the vehicle. Always use floor jacks. Bottle jacks can slip, allowing the vehicle to fall, which could result in damage to the vehicle, serious injury, or death.

**NOTICE:**

Do not place jack stands under any of the suspension components; doing so could cause suspension component damage. Jack stands can be placed at any point below the axle, including the differential area.

1. Using the floor jack, raise the vehicle to remove any jack stands used to support the vehicle.
2. Slowly lower the vehicle to the ground.

24.08 Front Towing Hookup With Removable Tow Hooks

24.08.01 General Information

**NOTICE:**

Towing the truck from the front and removing all of the drivelines is the approved method for towing DTNA products. Towing any other way is not preferred.

**DANGER:**

When working on the vehicle, shut down the engine, set the parking brake, and chock the tires. Before working under the vehicle, always place jack stands under the frame rails to ensure the vehicle can not drop. Failure to follow these steps could result in serious personal injury or death.

**WARNING:**

Do not tow an unbraked vehicle if the combined weight of both vehicles is more than the sum of the gross axle weight ratings (GAWR) of the towing vehicle. Otherwise brake capacity will be inadequate, which could result in personal injury or death.

24.08.02 Use of Tow Hooks

Tow hooks are not designed for on-road towing of the vehicle, but to recover and move the vehicle to a position where it can be hooked up properly for front towing.

**NOTICE:**

When using tow hooks to move the vehicle, do not pass a sling (for example, a rope or chain) from one hook to another. Known as reeving, this practice is **not** permissible in most industrial applications of towing and hoisting. Reeving can overload the hooks and result in damage to the vehicle. See Fig.360,, page 431.



09/21/2017

f311215

IMPORTANT: Do not reeve when towing.

1. Tow Hook

2. Chain

Fig 410, Reeving

1. Disconnect the battery ground cables.



NOTICE:

Failure to protect the frame rails from the chains could cause damage, leading to eventual frame failure.

2. On dual drive axles, if the vehicle is to be lifted and towed, chain the forward rear-axle assembly to the vehicle frame. Use protection to keep the chains from damaging the frame.
3. Open the hood. Remove the tow hooks, located behind the driver's-side bumper. See Fig.361, [Tow Hooks](#). Close and latch the hood.

**NOTICE:**

New or ungreased tow hooks may be hard to install. Tow hooks that are not properly installed may be damaged or break.

4. Install the tow hooks onto the tow hook receivers through the tow hook holes in the bumper, rotating the hooks so the hook opening faces down. See Fig.362, [Tow Hooks Installed, Facing Down](#). Pull the tow hooks to ensure they are securely engaged in the tow hook receivers.



06/14/2017

f130146

Fig 411, Tow Hooks

06/14/2017

f130147

Fig 412, Tow Hooks Installed, Facing Down

5. Lower the stinger assembly so that it is level and approximately 1 inch (0.3 cm) off the ground. Back the tow truck so that the crossbar with lift adaptors is within 6 inches (15 cm) of the Aero bumper. See Fig. 363, [Positioning the Stinger Assembly](#).



06/07/2022

f130149

Fig 413, Positioning the Stinger Assembly

**NOTICE:**

When using tow hooks to move the vehicle, do not pass a sling (for example, a rope or chain) from one hook to another. Known as reeving, this practice is **not permissible in most industrial applications of towing and hoisting**. Reeving can overload the hooks and result in damage to the vehicle.

6. Pull the tow cables out of the tow truck and connect the tow cable lifting hooks onto the tow hooks, then extend the recovery boom within 4 to 6 inches (10 to 15 cm) of being vertical of the tow hooks. See Fig. 364, [Tow Cables Connected to the Tow Hooks](#).
7. Lift the front of the truck until there is enough clearance for the stinger and crossbar to pass under the bumper. See Fig.365, [Moving the Stinger and Crossbar Under the Bumper](#).

If enough clearance cannot be gained with a single lift, jack stands or other means capable of supporting the weight on the front axle must be used while the cables are shortened to allow a second lift.



06/14/2017

f130150

Fig 414, Tow Cables Connected to the Tow Hooks



Fig 415, Moving the Stinger and Crossbar Under the Bumper



WARNING:

Failure to chock the tires or connect the tow truck's air brake system before releasing the spring parking brakes could allow the disabled vehicle to suddenly roll. This could cause property damage or personal injury.

8. Chock the rear tires.



NOTICE:

Reference the applicable axle manufacturer's information to avoid damaging the axle when towing the truck.

9. Use mid-rise or high-rise forks, or lift adaptors (part number 0200020) on the crossbar to provide clearance for the aerodynamic bumper. See Fig. 366, [Lift Adaptors Installed on the Crossbar](#) and Fig. 367, [Backing the Tow Truck with Lift Adaptors on the Crossbar](#).

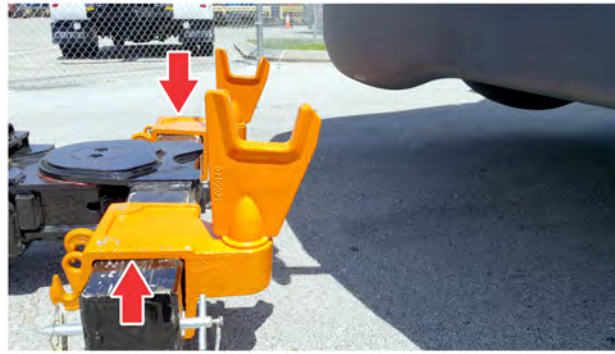

06/14/2017

f130152

Fig 416, Lift Adaptors Installed on the Crossbar

06/14/2017

f130153

Fig 417, Backing the Tow Truck with Lift Adaptors on the Crossbar

10. Extend the stinger and place the lift adaptors under the axle. Make certain the lift adaptors are under the front suspension springs between the U-bolts. See Fig. 368, [Positioning the Stinger with Lift Adaptors Under the Axle](#) and Fig. 369, [Stinger with Lift Adaptors Under the Axle \(tow truck shown\)](#).

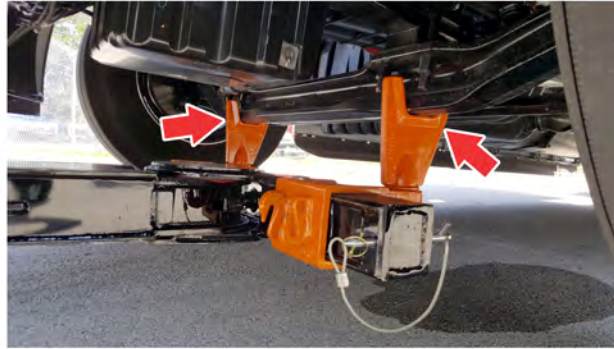

06/14/2017

f130154

Fig 418, Positioning the Stinger with Lift Adaptors Under the Axle



06/14/2017

f130155

Fig 419, Stinger with Lift Adaptors Under the Axle (tow truck shown)

11. Secure the axle to the crossbar with a chain or ratchet strap.



NOTICE:

Failure to remove the driveline(s) or the drive axle shafts when towing the vehicle with the rear wheels on the ground could result in damage to the transmission and other parts.

12. Use a paint pen to mark the drivelines in as built condition, and then remove the driveline, the interaxle driveline (if equipped), for each axle that may touch the ground during the towing process. Store the drivelines and U-joints in a secure location so they will not come off during transport.
13. Remove the tow cables from the tow hooks and retract the recovery boom. See Fig. 370, [Retracting the Recovery Boom](#).



Fig 420, Retracting the Recovery Boom

14. Remove the tow hooks from the bumper.

IMPORTANT: On trucks equipped with a front air suspension, either air pressure must be supplied to the secondary air system or the front suspension must be blocked to operating height with wooden spacers and the axle chained to the frame to prevent damage to the truck.

15. Connect the air and electrical supply lines from the tow truck to the truck being towed.
16. Connect the clearance lights, taillights, and signal lights. Connect any special towing lights required by local regulations.
17. Release the park brake and remove the chocks from the rear tires.
18. Use the stinger to pull the truck close to the back of the tow truck for final towing position. See Fig. 371, [Final Towing Position](#).



Fig 421, Final Towing Position

19. Connect the safety chains. See Fig. 372, [Safety Chains Connected on the Towed Vehicle](#).



06/14/2017

f130158

Fig 422, Safety Chains Connected on the Towed Vehicle

25.01 Telematics Information and Terms of Use 440

- 25.01.01 General Information 440
- 25.01.02 Telematics Information We Collect and Why We Collect it 440
- 25.01.03 What We Do With Telematics Information and Who We Share it With 441
- 25.01.04 Collection Method 441
- 25.01.05 Safeguards 441
- 25.01.06 Your Consent 441
- 25.01.07 Your Rights 441
- 25.01.08 Privacy Statement Changes 442

25.02 Frequency Bands and Maximum Transmission Output 442

- 25.02.01 Wireless Applications on the Vehicle 442
- 25.02.02 The Common Telematics Platform 442

25. Telematics Data

25.01 Telematics Information and Terms of Use

25.01.01 General Information

Your vehicle may be equipped with one or more devices that gather certain information (listed below) about the vehicle and the environment in which it is operating. These devices may periodically send this information ('telematic information') to Daimler Truck North American LLC (DTNA). Additionally DTNA and its dealers may manually retrieve 'telematics information' from devices on the vehicle for the purposes described below.

25.01.02 Telematics Information We Collect and Why We Collect it

The 'telematics information' we collect may include, but is not limited to, the following information about the vehicle:

- performance
- operation
- location
- speed
- trips
- travel history
- stop and idle times
- fuel consumption
- fault codes
- diagnostic information
- steering performance
- braking performance
- air bag deployment
- seatbelt use
- decelerations
- other information relating to the performance, operation, health and safety of the vehicle.

DTNA gathers this information to improve the performance, operation, health and safety of your vehicle and other DTNA vehicles and products. Information is gathered:

- **To enable your subscription services.** DTNA and other third party service providers have developed a variety of applications and services that are now available to you to optimize the performance, use, reliability and safe operation of your vehicle. These services are enabled by the telematics information we receive from your vehicle and will likely be made more effective in the future by the use of that telematics information and similar information we receive from other DTNA vehicles.
- **To make your vehicle safer and to improve its performance.** Depending on the type of devices installed on your vehicle, DTNA may periodically update your vehicle's on-board software to improve the performance and safe use of the vehicle. We may need to obtain certain telematics information to ensure the effectiveness of these updates.
- **To monitor and manage the health and efficiency of your vehicle.** Telematics information from your vehicle may be used by DTNA and its affiliates, dealers, and service providers to more effectively diagnose and resolve problems with your vehicle and to help you maintain it.
- **To improve your customer service experience.** Telematics information may be used by DTNA and its affiliates, dealers, and service providers to provide you a more efficient and effective customer service experience in conjunction with vehicle service, maintenance, field service campaigns and recalls.

- **For product development and product improvement.** Telematics information may be analyzed and used to identify and resolve performance and safety issues and to develop improvements to our products that will benefit you and our future customers.
- **To develop more meaningful product marketing.** Telematics information may be used to provide more customized and meaningful information to our customers regarding products and services that best satisfy their operational requirements and improve the performance of their businesses.
- **To help match our customers with the right products.** Telematics information may be used to develop future products and services that best satisfy the operational requirements of our customers.

25.01.03 What We Do With Telematics Information and Who We Share it With

DTNA may use telematics information for any purpose allowed by law, including but not limited to using the information for any of the purposes described in this chapter. DTNA may share telematics information with its service providers, affiliates, subsidiaries, dealers, and distributors, but only for lawful business purposes. This may include third parties who process information on behalf of DTNA, third parties who you authorize directly to receive information from us, and law enforcement agencies pursuant to applicable law.

DTNA may also combine telematics information it obtains from your vehicle with data from others, anonymize and de-identify that aggregated data, and use and disclose that aggregated data and derivatives of it indefinitely and for any purpose whatsoever, including sharing it with third parties for any purpose without restriction. DTNA will be the exclusive owner of all rights, title and interests in and to all aggregated data. You will not have any rights in any aggregated data or any derivatives or proceeds of it. DTNA shall not have any obligation to provide any aggregated data to you or to compensate you for any use or disclosure of any aggregated data.

25.01.04 Collection Method

The telematics information may be transmitted automatically or manually from the devices on your vehicle to DTNA or Detroit Diesel Corporation (DDC) through diagnostic tools, including but not limited to DDC DiagnosticLink.

25.01.05 Safeguards

DTNA will use reasonable data security systems and procedures in an effort to protect telematics information from unauthorized use, access, disclosure, distribution, loss or alteration. We do this through physical, electronic and procedural safeguards that are designed to protect the confidentiality, integrity and availability of telematics information. However, no security system is perfect. DTNA cannot guarantee that telematics information will not be hacked, deleted, intercepted, or altered.

DTNA will also require other parties to whom telematics information is disclosed to take reasonable steps to protect the telematics information from unauthorized use, access, disclosure, distribution, loss, or alteration.

25.01.06 Your Consent

By continuing to provide to us, or allowing us to receive or retrieve, telematics information through the devices on your vehicle, you consent to its collection and use as described in this chapter.

Although some information may be transferred to and processed in countries without laws providing the same level of data protection as your country, our use and disclosure of your information is subject to these terms of use regardless of where your information is transferred.

If you have subscribed to a subscription service such as Virtual Technician or Detroit Analytics, the Telematics Terms and Conditions for that service will apply to DTNA's collection, storage, use, and sharing of the data covered by those Telematics Terms and Conditions.

25.01.07 Your Rights

You may ask DTNA to discontinue receiving and retrieving telematics information from the devices on your vehicle. If you do so, you will be unable to receive telematics subscription services relating to your vehicle and remotely receive important vehicle software updates, among other things. If you are interested in that option, please contact DTNA at: **DetroitConnect@Daimler.com**.

25.01.08 Privacy Statement Changes

DTNA reserves the right to amend these terms of use from time to time. Changes will be reflected in the online version of this document, which can also be found at: <https://freightliner.com/service/driver-maintenance-manuals/>. **By continuing to provide to us, or allowing us to receive or retrieve, Telematics Information through the devices on your vehicle, you consent to and accept those changes.**

NOTE: These terms of use do not apply to aftermarket telematics devices that may be provided by others or configured to send information to someone other than DTNA or its affiliates, dealers or service providers.

25.02 Frequency Bands and Maximum Transmission Output

25.02.01 Wireless Applications on the Vehicle

Frequency Bands and Maximum Transmission Output			
Component	Service	Frequency Band	Transmission Output
CTP2019DTNA	4G LTE	LTE FDD Band 2 LTE FDD Band 4 LTE FDD Band 5 LTE FDD Band 7 LTE FDD Band 17	0.25 W (Power Class 3)
	3G UMTS/HSDPA/HSUPA	UMTS Band 1 UMTS Band 2 UMTS Band 4 UMTS Band 5 UMTS Band 8	0.25 W (Power Class 3)
	2G GSM/GPRS/EDGE	GSM 850 MHz E-GSM 900 MHz	2 W (Power Class 4)
		DCS 1800 MHz PCS 1900 MHz	1 W (Power Class 1)
	WLAN (IEEE 802.11b)	2.4 GHz band	20 mW
	WLAN (IEEE 802.11g/n)	2.4 GHz band	20 mW
	Bluetooth	2.4 GHz band	10 mW
	GPS / GLONASS	1575 and 1602 MHz	Receive only

Table 36, Frequency Bands and Maximum Transmission Output

25.02.02 The Common Telematics Platform

The Detroit Connect Platform is the connectivity module of Daimler Truck North America. It receives and transmits data in real time and is the interface for all connectivity-related services. Both the Detroit Connect Platform and a valid agreement is required for use of the Detroit Connect services.

Vehicle antennas (WLAN/BT/CellularNetworks) are located inside and behind the dashboard on the passenger side. In both locations, the shortest possible distance between the antennas and any human or animal body part inside the vehicle cabin is greater than 8 in (20 cm).

Therefore Daimler Truck North America LLC declares that the radio equipment type CTP2019DTNA is in compliance with Directive 2014/53/EU.



CONTACT INFORMATION

For questions, please create a Service Technical Request using the DTTS Application on the DTNA Portal.