



108SD Plus and 114SD Plus Maintenance Manual

**Models: 108SD Plus
114SD Plus**

Table of Contents

1. Introduction	5
2. General Information	11
3. Engine	27
4. Air Intake	33
5. Air Compressor	37
6. Alternators and Starters	39
7. Engine Cooling/Radiator	43
8. Clutch	49
9. Transmission	59
10. Frame and Frame Components	75
11. Suspension	83
12. Front Axle	95
13. Rear Axle	109
14. Wheels and Tires	123
15. Driveline	127
16. Brakes	131
17. Steering	159
18. Fuel	165
19. Exhaust	183
20. Electrical, Instruments and Controls	189
21. Cab	193
22. Heater and Air Conditioner	195
23. Hood, Grille, and Cab Fenders	199

1.01 Foreword.....6

1.02 Service Publications.....6

1.03 Page Description.....8

1. Introduction

1.01 Foreword

Foreword

Instructions and procedures are those recommended by Freightliner Trucks, or the component manufacturer. Maintenance schedules and additional service information are included in the product Maintenance Manual.

IMPORTANT: Descriptions and specifications in this manual were in effect at the time of printing. Daimler Truck North America LLC reserves the right to discontinue models and to change specifications or design at any time without notice and without incurring obligation. Descriptions and specifications contained in this publication provide no warranty, expressed or implied, and are subject to revision and editions without notice.

Refer to <https://northamerica.daimlertruck.com/> for more information, or contact Daimler Truck North America LLC at the address below.

Environmental Concerns and Recommendations

Whenever you see instructions in this manual to discard materials, you should attempt to reclaim and recycle them. To preserve our environment, follow appropriate environmental rules and regulations when disposing of materials.

**NOTICE:**

Do not replace suspension, axle, or steering parts (such as springs, wheels, hubs, and steering gears) with used parts. Used parts may have been subjected to collisions or improper use and have undetected structural damage.

© 2025 Daimler Truck North America LLC

All rights reserved. No part of this publication, in whole or in part, may be translated, reproduced, stored in a retrieval system, or transmitted in any form by any means, electronic, mechanical, photocopying, recording, or otherwise, without the prior written permission of Daimler Truck North America LLC. Daimler Truck North America LLC is a Daimler company.

Daimler Truck North America LLC Service Systems and Documentation

P.O. Box 3849

Portland, OR

97208-3849

1.02 Service Publications

Descriptions of Service Publications

Daimler Truck North America (DTNA) LLC distributes the following major service publications in paper and electronic formats. Refer to DTNA TechLit for more information.

Workshop/Service Manual

Workshop and service manuals contain service and repair information for all vehicle systems and components, except for major components such as engines, transmissions, and rear axles. Each workshop and service manual section is divided into subjects that can include general information, principles of operation, removal, disassembly, assembly, installation, and specifications. Workshop and service manuals contain service and repair information for all vehicle systems and components installed in our plants.

Maintenance Manual

Maintenance manuals contain routine maintenance procedures and intervals for vehicle components and systems. They have information such as lubrication procedures and tables, fluid replacement procedures, fluid capacities, and

specifications. Maintenance manuals do not contain detailed repair or service information. Maintenance manuals should not be used for covering plant quality or quality assurance issues. The purpose of maintenance manuals is to increase the life of the component being maintained. Except for federally required maintenance items, like mufflers, these are recommendations, not requirements.

Troubleshooting Manual

Troubleshooting manuals contain diagnostic procedures for determining the root cause of fault codes and symptoms in vehicle components and systems, including multiplexed systems. In addition to fault codes and symptoms, testing procedures and 'how to' sections are included in troubleshooting manuals. The troubleshooting manual does not include information on the removal, inspection, or installation of components.

Technical Service Bulletins (TSBs)

TSBs provide issue notifications to the service network. They are intended for issues that can be addressed when the expected symptom or failure is present when the vehicle arrives in the shop for normal service. TSBs should not be used to bring a vehicle in for inspection, or update a vehicle before a failure has occurred. In the literature request system, they have a higher priority than Workshop, Drivers, and Maintenance Manuals. All TSBs must have a clearly defined symptom or customer complaint that is causing the customer to bring the vehicle into the dealership. If they do not, dealerships will take it as an expectation that they should be proactively checking every single vehicle when they come in. TSBs are not visible to vehicle owners and operators.

Parts Bulletin (PB) or Parts Technical Bulletin (PTB)

PBs are used to communicate information on parts. These bulletins contain lists of parts and Bills of Material (BOMs) needed to do replacement and upgrade procedures. PBs do not contain service procedures or Standard Repair Times (SRTs).

Customer Service Announcements (CSAs)

CSAs are used to communicate information to the dealer or distributor network. They remain on DTNA Portal and continue to be communicated via myComm.

Tool Letters (TLs)

TLs are used to communicate the release of both physical and electronic tools. They remain on DTNA Portal and continue to be communicated via myComm.

18SP Letters

18SPs are special procedures or instructions that are included in unique service parts kits. They are available on TechLit in the event that someone lost their kit's original copy.

Original Equipment Manufacturer (OEM) Letters

OEM letters are other suppliers' letters that we make available on TechLit as a courtesy.

DTNA Portal

Service and parts applications and information can be accessed on the DTNA Portal. While there is some content available to users without logging in, access to most content and applications on DTNA Portal requires authentication by registered users. Registration requirements for each user type can be found on the main landing page before logging in. In addition to accessing Aftermarket applications, DTNA Portal can be used for searching all content published within DTNA Portal pages as well as within many applications. The following applications can be accessed via DTNA Portal.

TechLit

Web-based service manuals can be accessed on the TechLit application.

PartsProX

PartsProX® is an electronic parts catalog system, showing the specified vehicle's build record.

EZWiring

EZWiring™ makes products' wiring drawings and floating pin lists available online for viewing and printing. EZWiring can also be accessed from within PartsProX.

Service Solutions

The Service Solutions application provides diagnostic assistance with Symptoms Search, by connecting to a large knowledge base gathered from technicians and service personnel. Solutions published within Service Solutions are routed through DTNA Compliance, but are not vetted through the normal reviews that service bulletins, service manuals, and campaigns go through. Content published should only be published on Service Solutions if it doesn't meet the criteria to be published in one of the more official publication types.

Vehicle Info

Vehicle Information is a single point of entry to search for DTNA and Detroit Diesel service information. This allows you to search for information specific to a vehicle or Detroit Diesel engine. Vehicle specifications, vehicle recalls and campaigns, warranty information, and vehicle literature can all be found within Vehicle Info. It also contains the registration information for the selected vehicle.

Warranty Lit

Review important warranty information including warranty manuals, letters, recall and field service information and more.

Recall Campaigns

Recall campaigns cover situations that involve service work or replacement of parts in connection with a recall notice. These campaigns pertain to matters of vehicle safety. All recall campaigns are distributed to dealers; customers receive notices that apply to their vehicles.

Field Service Campaigns

Field service campaigns are concerned with non-safety-related service work or replacement of parts. All field service campaigns are distributed to dealers; customers receive notices that apply to their vehicles.

Warranty Manual

This manual covers the provisions and procedures under which authorized service facilities will be reimbursed for warranty-related work on products, parts, and accessories manufactured or supplied by DTNA.

1.03 Page Description

For an example of a *108SD and 114SD Plus Maintenance Manual* page, see Fig. 1, [Example of a 108SD Plus and 114SD Plus Maintenance Manual Page](#).

Transmission 26

26-01 Transmission Fluid Level Check

NOTICE

Operating a transmission with the fluid level higher or lower than recommended can result in transmission damage. Do not overfill the transmission.

Do not mix types and brands of fluid, because of possible incompatibility. Do not use fluid additives, friction modifiers, extreme-pressure gear fluids, or multiviscosity lubricants.

Eaton Fuller

NOTE: Check the transmission fluid level with the transmission at operating temperature.

1. Park the vehicle on a level surface, apply the parking brakes, and chock the tires.
2. Clean the area around the fill plug, then remove the plug from the side of the gear case.
3. Using your gloved finger or a bent pipe cleaner, check if the fluid is level with the fill opening. See Fig. 1.

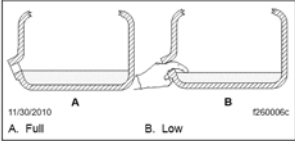

Fig. 1. Checking Transmission Fluid Level

4. If the fluid level is low, check the transmission for leaks, and correct as needed.
5. If needed, add Eaton-approved fluid until it is level with the lower edge of the fill opening. Eaton-approved fluid, such as the Roadranger SAE 50 product, meets the requirements of the PS-164 Rev. 7 lubricant specification. For more information about Eaton lubricant specifications and suppliers, call 1-800-826-4357 or see www.roadranger.com.

6. Clean the fill plug, then install it. Tighten the plug as follows:

- 25 to 35 lbf-ft (34 to 48 N-m) for transmissions with 3/4-inch pipe threads.
- 60 to 75 lbf-ft (81 to 102 N-m) for transmissions with 3/4-inch pipe threads.

Allison

NOTE: For Allison transmissions equipped with an oil level sensor, the transmission fluid level can be checked electronically. For more information, refer to the Allison Transmission website, www.allisontransmission.com.

Cold Check

Clean all dirt from around the end of the fluid fill tube before removing the dipstick. Do not allow foreign matter to enter the transmission. Dirt or foreign matter in the hydraulic system may cause undue wear of transmission parts, make valves stick, and clog passages.

It is important to check the fluid level cold to determine if the transmission has a sufficient amount of fluid to be safely operated until a hot check can be performed.

1. Park the vehicle on a level surface, apply the parking brakes, and chock the tires.
2. Run the engine for at least one minute.
3. Shift from DRIVE to NEUTRAL, and then shift to REVERSE to fill the hydraulic system.
4. Shift to NEUTRAL and allow the engine to idle at 500 to 800 rpm.
5. With the engine running at idle, remove the dipstick from the tube and wipe it clean.
6. Insert the dipstick into the tube, then remove it.
7. Check the fluid level reading, then repeat the check procedure to verify the reading.

If the fluid level is within the COLD RUN band, the transmission may be operated until the fluid is hot enough to perform a hot check.

If the fluid level is not within the COLD RUN band, add or drain fluid as needed to adjust the fluid level to the middle of the COLD RUN band. See Fig. 2.

11/30/2010 1250006c

108SD Plus and 114SD Plus Maintenance Manual, 03/31/2023 26/1

03/02/2023

f020189

- A. Maintenance Operation Number consists of the Group Number followed by the Sequence Number
- B. Group Title
- C. Group Number

- D. Vehicle Name
- E. Release Date
- F. Group Number/Page Number

Fig 1, Example of a 108SD Plus and 114SD Plus Maintenance Manual Page

2.01 Determining Scheduled Maintenance Intervals	12
2.02 Maintenance Schedules	13
2.03 Maintenance Intervals for Schedule I	14
2.04 Maintenance Intervals for Schedules II and III.....	15
2.05 Overview of Maintenance Operations	18
2.06 Initial Maintenance (IM) Operations	21
2.07 M1 Maintenance Operations	21
2.08 M2 Maintenance Operations	22
2.09 M3 Maintenance Operations	23
2.10 M4 Maintenance Operations	24
2.11 M5 Maintenance Operations	24
2.12 Noise Emission Controls	25

2. General Information

2.01 Determining Scheduled Maintenance Intervals

Performing regular maintenance will help ensure that your vehicle delivers safe, reliable service and optimum performance. A proper maintenance program will also help to minimize downtime and safeguard warranties.

To determine the correct maintenance intervals for your vehicle, you must first determine the type of service or conditions the vehicle will be operating in. Most vehicles operate in conditions that fall within one of two schedules. Before placing your vehicle in service, determine which schedule applies to your vehicle.

Schedules I-III

Schedule I (severe service) applies to vehicles that travel up to 6,000 miles (10,000 kilometers) annually or that operate under severe conditions. Examples of Schedule I usage are:

- operation on extremely poor roads or where there is heavy dust accumulation
- constant exposure to extreme hot, cold, salt air, or other extreme climates
- frequent short-distance travel
- construction-site operation
- city operation such as fire truck and garbage truck.
- farm operation

Schedule II (short-haul transport) applies to vehicles that travel 6,000 miles (10,000 kilometers) or more annually and operate under normal conditions. Examples of Schedule II usage are:

- operation primarily in cities and densely populated areas
- local transport with infrequent freeway travel
- high percentage of stop-and-go travel

Schedule III (long-haul transport) applies to vehicles that travel more than 60,000 miles (100,000 kilometers) annually with minimal city or stop-and-go operation. Examples of Schedule III usage are:

- regional delivery that is mostly freeway miles.
- interstate transport
- any road operation with high annual mileage

Maintenance Schedules

After determining the schedule appropriate to your vehicle, refer to the Maintenance Schedules to determine when to perform the Initial Maintenance (IM) and the frequency of performing subsequent maintenance intervals for each schedule.

Maintenance Intervals

Refer to Maintenance Intervals for Schedule I, Schedule II, and Schedule III to determine which maintenance interval(s) should be performed when your vehicle reaches the mileage or hours of operation listed in these tables.

Maintenance Operations

Groups 01 through 83 in this manual have an index at the beginning of each group. The index lists the title of maintenance operations and the Maintenance Operation (MOP) numbers for that group. Follow the instructions under the MOP number to perform the required maintenance.

In addition to the maintenance operations required for the maintenance interval, perform all the daily maintenance procedures in the [General Information, Daily Pretrip Inspections and Maintenance](#) topic in the **Pretrip Inspection and Daily Maintenance** section of the *108SD and 114SD Plus Driver's Manual*.

2.02 Maintenance Schedules

Schedule	Maintenance Intervals				
	Maintenance Interval	Frequency	Frequency	Frequency	Frequency
Schedule I¹ (severe service) for vehicles that travel up to 6,000 miles (10,000 km) annually	Initial Maintenance (IM)	first	1000	1600	100
	Maintenance 1 (M1)	every	1000	1600	100
	Maintenance 2 (M2)	every	4000	6400	400
	Maintenance 3 (M3)	every	8000	12 800	800
	Maintenance 4 (M4)	every	16,000	25 600	1600
	Maintenance 5 (M5)	every	32,000	51 200	3200
Schedule II (short-haul transport) for vehicles that travel 6,000 miles (10,000 km) or more annually	Initial Maintenance (IM)	first	8000	12 000	-
	Maintenance 1 (M1)	every	8000	12 000	
	Maintenance 2 (M2)	every	16,000	24 000	
	Maintenance 3 (M3)	every	32,000	48 000	
	Maintenance 4 (M4)	every	64,000	96 000	
	Maintenance 5 (M5)	every	128,000	192 000	
Schedule III (long-haul transport) for vehicles that travel 60,000 miles (100,000 km) or more annually	Initial Maintenance (IM)	first	25,000	40,200	-
	Maintenance 1 (M1)	every	25,000	40,200	
	Maintenance 2 (M2)	every	50,000	80,400	
	Maintenance 3 (M3)	every	50,000	80,400	
	Maintenance 4 (M4)	every	100,000	160,800	
	Maintenance 5 (M5)	every	300,000	482,400	

2.03 Maintenance Intervals for Schedule I

Maintenance Sequence	Maintenance Interval	Service Date	Miles	km	Hours
1st	IM and M1		1000	1600	100
2nd	M1		2000	3200	200
3rd	M1		3000	4800	300
4th	M1 and M2		4000	6400	400
5th	M1		5000	8000	500
6th	M1		6000	9600	600
7th	M1		7000	11 200	700
8th	M1, M2, and M3		8000	12 800	800
9th	M1		9000	14 400	900
10th	M1		10,000	16 000	1000
11th	M1		11,000	17 600	1100
12th	M1 and M2		12,000	19 200	1200
13th	M1		13,000	20 800	1300
14th	M1		14,000	22 400	1400
15th	M1		15,000	24 000	1500
16th	M1, M2, M3, and M4		16,000	25 600	1600
17th	M1		17,000	27 200	1700
18th	M1		18,000	28 800	1800
19th	M1		19,000	30 400	1900
20th	M1 and M2		20,000	32 000	2000
21st	M1		21,000	33 600	2100
22nd	M1		22,000	35 200	2200
23rd	M1		23,000	36 800	2300
24th	M1, M2, and M3		24,000	38 400	2400
25th	M1		25,000	40 000	2500

Table 2, Maintenance Sequence for Schedule I

Maintenance Sequence	Maintenance Interval	Service Date	Miles	km	Hours
26th	M1		26,000	41 600	2600
27th	M1		27,000	43 200	2700
28th	M1 and M2		28,000	44 800	2800
29th	M1		29,000	46 400	2900
30th	M1		30,000	48 000	3000
31st	M1		31,000	49 600	3100
32nd	M1, M2, M3, M4, and M5		32,000	51 200	3200

2.04 Maintenance Intervals for Schedules II and III

Maintenance Sequence	Maintenance Interval	Service Date	Miles	km
1st	IM and M1		8000	12 000
2nd	M1 and M2		16,000	24 000
3rd	M1		24,000	36 000
4th	M1, M2, and M3		32,000	48 000
5th	M1		40,000	60 000
6th	M1 and M2		48,000	72 000
7th	M1		56,000	84 000
8th	M1, M2, M3, and M4		64,000	96 000
9th	M1		72,000	108 000
10th	M1 and M2		80,000	120 000
11th	M1		88,000	132 000
12th	M1, M2, and M3		96,000	144 000
13th	M1		104,000	156 000
14th	M1, and M2		112,000	168 000
15th	M1		120,000	180 000

Table 3, Maintenance Sequence for Schedule II

Maintenance Sequence	Maintenance Interval	Service Date	Miles	km
16th	M1, M2, M3, M4, and M5		128,000	192 000
17th	M1		136,000	204 000
18th	M1 and M2		144,000	216 000
19th	M1		152,000	228 000
20th	M1, M2, and M3		160,000	240 000
21st	M1		168,000	252 000
22nd	M1 and M2		176,000	264 000
23rd	M1		184,000	276 000
24th	M1, M2, M3, and M4		192,000	288 000
25th	M1		200,000	300 000
26th	M1 and M2		208,000	312 000
27th	M1		216,000	324 000
28th	M1, M2, and M3		224,000	336,000
29th	M1		232,000	348 000
30th	M1 and M2		240,000	360 000
31st	M1		248,000	372 000
32nd	M1, M2, M3, M4, and M5		256,000	384 000

Maintenance Sequence	Maintenance Interval	Service Date	Miles	km
1st	IM and M1		25,000	40,200
2nd	M1 ,M2 and M3		50,000	80,400
3rd	M1		75,000	120,600
4th	M1, M2, M3 and M4		100,000	160,800
5th	M1		125,000	201,000
6th	M1, M2 and M3		150,000	241,200

Table 4, Maintenance Sequence for Schedule III

Maintenance Sequence	Maintenance Interval	Service Date	Miles	km
7th	M1		175,000	281,400
8th	M1, M2, M3, and M4		200,000	321,600
9th	M1		225,000	361,800
10th	M1 ,M2 and M3		250,000	402,000
11th	M1		275,000	442,200
12th	M1, M2, M3, M4 and M5		300,000	482,400
13th	M1		325,000	522,600
14th	M1, M2 and M3		350,000	562,800
15th	M1		375,000	603,000
16th	M1, M2, M3,and M4		400,000	643,200
17th	M1		425,000	683,400
18th	M1, M2 and M3		450,000	723,600
19th	M1		475,000	763,800
20th	M1, M2, M3 and M4		500,000	804,000
21st	M1		525,000	844,400
22nd	M1 ,M2 and M3		550,000	884,400
23rd	M1		575,000	924,600
24th	M1, M2, M3, M4 and M5		600,000	964,800
25th	M1		625,000	1,005,000
26th	M1, M2 and M3		650,000	1,045,200
27th	M1		675,000	1,085,400
28th	M1, M2, M3 and M4		700,000	1,125,600
29th	M1		725,000	1,165,800
30th	M1, M2 and M3		750,000	1,206,000
31st	M1		775,000	1,246,200
32nd	M1, M2, M3 and M4		800,000	1,286,400

2.05 Overview of Maintenance Operations

Maintenance Operation No.	Maintenance Operation Title	Maintenance Intervals				
		IM / M1	M2	M3	M4	M5
3.02.01	3.02.01 General Information			.	.	.
4.01	4.01 Inspection and Replacement of the Air Cleaner Element				.	.
5.02	5.02 Inspection of the Air Compressor	
6.02	6.02 Checking the Alternator, Battery, and Starter				.	.
7.02	7.02 Inspection of the Radiator Cap	
7.03	7.03 Radiator Pressure Flush and Coolant Change				.	.
7.04.01	7.04.01 BorgWarner eViscous Fan Clutch	
8.02	8.02 Eaton Fuller Clutch Release Bearing Lubrication
8.03.01	8.03.01 Flushing					.
8.04	8.04 Clutch Adjusting, Manually Adjusted Clutches
9.02	9.02 Detroit® Automated Transmission Fluid Change and Magnetic Plug Cleaning				.	
9.03	9.03 Detroit® Automated Transmission Fluid Level Inspection			.		
9.04.01	9.04.01 Eaton Fuller Manual and Automated
9.05.01	9.05.01 Draining ¹	
9.06	9.06 Allison and Eaton Fuller Transmission Breather Checking
9.07	9.07 Eaton Fuller Transmission Air Filter/Regulator Element Cleaning	
9.08.01	9.08.01 General information			.	.	.
10.02	10.02 Frame Fastener Torque Check	.			.	.
10.03.01	10.03.01 Fontaine

Table 5, Maintenance Operations

10.04.01	10.04.01 Fontaine
10.05	10.05 Trailer Electrical Connector Lubricating
11.02.01	11.02.01 Inspection of the Freightliner Spring Front and Rear Suspension Spring Assemblies
11.03	11.03 Suspension U-Bolt Torque Checking
11.04	11.04 TufTrac Suspension Gen2 I-Bolt Torque Checking
12.02.01	12.02.01 Detroit® Axles ²
12.03.01	12.03.01 Detroit Axles ²
12.04.01	12.04.01 Axles With Unitized Wheel Ends
12.05	12.05 Tie Rod End Inspecting
12.06.01	12.06.01 General Information
12.07.01	12.07.01 Drive Axle Alignment Checking
12.08.01	12.08.01 General Information
13.02.01	13.02.01 Detroit®
13.03	13.03 Axle Breather Checking
13.04.01	13.04.01 General Information
14.01	14.01 Wheel Nut Checking
14.02	14.02 Tire Check
15.02	15.02 Driveline Inspecting
15.03	15.03 Driveline Lubricating
16.02	16.02 Air Brake System Valve Inspection
16.03.01	16.03.01 AD-9 ³
16.04.01	16.04.01 Operational Test
16.05	16.05 Bosch Hydraulic Brake System Inspection
16.06.01	16.06.01 Dana Spicer and Haldex

Table 5, Maintenance Operations

16.07	16.07 Meritor Camshaft Bracket Lubrication	
16.08	16.08 Meritor Slack Adjuster Lubrication
16.09.01	16.09.01 Air Dryer AD-9, AD-IP, AD-IS/DRM Check Procedure	
16.10	16.10 Bendix E-6 Foot Control Valve Inspection and Lubrication					.
16.11.01	16.11.01 Parking Brake Operational Check
16.12	16.12 Hydro-Max™ Brake System Inspection
16.13	16.13 Replacement of the WABCO System Saver Air Dryer Desiccant Cartridge ⁴
16.14.01	16.14.01 Inspection Procedure ⁴
17.02	17.02 Drag Link Inspection			.	.	.
17.05	17.05 Power Steering Filter Changing				.	.
17.04	17.04 Power Steering Gear Lubrication
17.03	17.03 Power Steering Fluid Changing					.
18.02	18.02 Tightening the Fuel Tank Band Nut	.				
18.03.01	18.03.01 Alliance				.	.
18.04.01	18.04.01 General Information
18.05	18.05 LNG Vacuum Integrity Testing			.	.	.
18.06	18.06 Inspecting the CNG Fuel System	
18.07	18.07 Replacement of the CNG High-Pressure Fuel Filter Element
18.08	18.08 Inspection of the CNG Fuel Cylinder			.	.	.
19.02	19.02 Replacement of the CAT CGI Bellows					.
20.01	20.01 Trailer Cable Inspection and Cleaning				.	
20.02	20.02 Inspection of the Electrical Component				.	

Table 5, Maintenance Operations

21.01	21.01 Mirror Folding Check				.	.
21.02	21.02 Aerodynamic Component Inspection
22.02.01	22.02.01 Inspection of the Refrigerant Compressor
22.03	22.03 Replacement of the HVAC Air Filter ⁵			.	.	.
23.01	23.01 Hood Rear Support Lubrication

2.06 Initial Maintenance (IM) Operations

NOTE: The IM Operations include the maintenance operations in Table 6, [Initial Maintenance \(IM\) Operations](#) and all those listed in [2.07 M1 Maintenance Operations](#).

Maintenance Operation No.	Maintenance Operation Title
2.07	2.07 M1 Maintenance Operations
10.02	10.02 Frame Fastener Torque Check
11.03	11.03 Suspension U-Bolt Torque Checking
12.04.01	12.04.01 Axles With Unitized Wheel Ends
12.07.01	12.07.01 Drive Axle Alignment Checking
18.02	18.02 Tightening the Fuel Tank Band Nut

2.07 M1 Maintenance Operations

IMPORTANT: After performing all operations listed in this table, perform all daily, weekly, and monthly maintenance operations listed in [General Information, Daily Pretrip Inspections and Maintenance](#) in the *108SD Plus and 114SD Plus Driver's Manual*.

Maintenance Operation No.	Maintenance Operation Title
8.02	8.02 Eaton Fuller Clutch Release Bearing Lubrication
8.04	8.04 Clutch Adjusting, Manually Adjusted Clutches
9.04.01	9.04.01 Eaton Fuller Manual and Automated
9.06	9.06 Allison and Eaton Fuller Transmission Breather Checking
10.03.01	10.03.01 Fontaine

Table 7, M1 Maintenance Operations

Maintenance Operation No.	Maintenance Operation Title
10.04.01	10.04.01 Fontaine
10.05	10.05 Trailer Electrical Connector Lubricating
11.02.01	11.02.01 Inspection of the Freightliner Spring Front and Rear Suspension Spring Assemblies
12.02.01	12.02.01 Detroit® Axles ¹
12.03.01	12.03.01 Detroit Axles ¹
12.05	12.05 Tie Rod End Inspecting
12.06.01	12.06.01 General Information ²
12.08.01	12.08.01 General Information
13.02.01	13.02.01 Detroit®
13.03	13.03 Axle Breather Checking
14.02	14.02 Tire Check
15.02	15.02 Driveline Inspecting
15.03	15.03 Driveline Lubricating
16.02	16.02 Air Brake System Valve Inspection
16.03.01	16.03.01 AD-9 ³
16.06.01	16.06.01 Dana Spicer and Haldex
16.08	16.08 Meritor Slack Adjuster Lubrication
16.11.01	16.11.01 Parking Brake Operational Check
16.12	16.12 Hydro-Max™ Brake System Inspection
16.13	16.13 Replacement of the WABCO System Saver Air Dryer Desiccant Cartridge ⁴
16.14.01	16.14.01 Inspection Procedure ⁴
17.04	17.04 Power Steering Gear Lubrication
18.04.01	18.04.01 General Information
18.07	18.07 Replacement of the CNG High-Pressure Fuel Filter Element ⁵
21.02	21.02 Aerodynamic Component Inspection
22.02.01	22.02.01 Inspection of the Refrigerant Compressor
23.01	23.01 Hood Rear Support Lubrication

2.08 M2 Maintenance Operations

NOTE: The M2 Maintenance Operations include the maintenance operations in Table 8, [M2 Maintenance Operations](#) and all those listed in [2.07 M1 Maintenance Operations](#).

Maintenance Operation No.	Maintenance Operation Title
2.07	2.07 M1 Maintenance Operations
5.02	5.02 Inspection of the Air Compressor
7.02	7.02 Inspection of the Radiator Cap
7.04.01	7.04.01 BorgWarner eViscous Fan Clutch
9.05.01	9.05.01 Draining ¹
9.07	9.07 Eaton Fuller Transmission Air Filter/Regulator Element Cleaning
12.06.01	12.06.01 General Information ²
16.07	16.07 Meritor Camshaft Bracket Lubrication
16.09.01	16.09.01 Air Dryer AD-9, AD-IP, AD-IS/DRM Check Procedure
18.06	18.06 Inspecting the CNG Fuel System
18.08	18.08 Inspection of the CNG Fuel Cylinder ³

2.09 M3 Maintenance Operations

NOTE: The M3 Maintenance Operations include the maintenance operations in Table 9, [M3 Maintenance Operations](#) and all those listed in both [2.07 M1 Maintenance Operations](#) and [2.08 M2 Maintenance Operations](#).

Maintenance Operation No.	Maintenance Operation Title
2.07	2.07 M1 Maintenance Operations
2.08	2.08 M2 Maintenance Operations
3.02.01	3.02.01 General Information
9.03	9.03 Detroit® Automated Transmission Fluid Level Inspection
9.08.01	9.08.01 General information
11.03	11.03 Suspension U-Bolt Torque Checking
12.04.01	12.04.01 Axles With Unitized Wheel Ends
14.01	14.01 Wheel Nut Checking
17.02	17.02 Drag Link Inspection
18.05	18.05 LNG Vacuum Integrity Testing
22.03	22.03 Replacement of the HVAC Air Filter ¹

2.10 M4 Maintenance Operations

NOTE: The M4 Maintenance Operations include the maintenance operations in Table 10, [M4 Maintenance Operations](#) and all those listed in [2.07 M1 Maintenance Operations](#), [2.08 M2 Maintenance Operations](#), and [2.09 M3 Maintenance Operations](#).

Maintenance Operation No.	Maintenance Operation Title
2.07	2.07 M1 Maintenance Operations
2.08	2.08 M2 Maintenance Operations
2.09	2.09 M3 Maintenance Operations
4.01	4.01 Inspection and Replacement of the Air Cleaner Element
6.02	6.02 Checking the Alternator, Battery, and Starter
7.03	7.03 Radiator Pressure Flush and Coolant Change
9.02	9.02 Detroit® Automated Transmission Fluid Change and Magnetic Plug Cleaning
10.02	10.02 Frame Fastener Torque Check
13.04.01	13.04.01 General Information
16.04.01	16.04.01 Operational Test
17.05	17.05 Power Steering Filter Changing
18.03.01	18.03.01 Alliance
20.01	20.01 Trailer Cable Inspection and Cleaning
20.02	20.02 Inspection of the Electrical Component
21.01	21.01 Mirror Folding Check

2.11 M5 Maintenance Operations

NOTE: The M5 Maintenance Operations include the maintenance operations in Table 11, [M5 Maintenance Operations](#) and all those listed in [2.07 M1 Maintenance Operations](#), [2.08 M2 Maintenance Operations](#), [2.09 M3 Maintenance Operations](#), and [2.10 M4 Maintenance Operations](#).

Maintenance Operation No.	Maintenance Operation Title
2.08	2.08 M2 Maintenance Operations
2.09	2.09 M3 Maintenance Operations
2.07	2.07 M1 Maintenance Operations
2.10	2.10 M4 Maintenance Operations
8.03.01	8.03.01 Flushing

Table 11, M5 Maintenance Operations

Maintenance Operation No.	Maintenance Operation Title
11.04	11.04 TufTrac Suspension Gen2 I-Bolt Torque Checking
16.03.01	16.03.01 AD-9
16.10	16.10 Bendix E-6 Foot Control Valve Inspection and Lubrication
16.13	16.13 Replacement of the WABCO System Saver Air Dryer Desiccant Cartridge
17.03	17.03 Power Steering Fluid Changing
19.02	19.02 Replacement of the CAT CGI Bellows

2.12 Noise Emission Controls

Federal Law, Part 205: Transportation Equipment Noise Emission Controls

Part 205, Transportation Equipment Noise Emission Controls, requires the vehicle manufacturer to furnish each new vehicle with written instructions for the proper maintenance, use, and repair of the vehicle by the ultimate purchaser to provide reasonable assurance of the elimination or minimization of noise emission degradation throughout the life of the vehicle. In compliance with the law, the Noise Emission Control Systems maintenance located in each applicable group within this manual, in conjunction with the vehicle workshop manual, provides these instructions to owners.

Recommendations for Replacement Parts

Replacement parts used for maintenance or repair of noise emission control systems should be genuine Freightliner parts. If other than genuine Freightliner parts are used for replacement or repair of components affecting noise emission control, the owner should be sure that such parts are warranted by their manufacturer to be equivalent to genuine Freightliner parts in performance and durability.

Freightliner Noise Emissions Warranty

Refer to the vehicle owner's warranty information book for warranty information concerning noise emission control systems.

Tampering with Noise Controls is Prohibited

Federal law prohibits the following acts or the causing thereof:

1. The removal or rendering inoperative by any person other than for purposes of maintenance, repair, or replacement, of any device or element of design incorporated into any new vehicle for the purpose of noise control prior to its sale or delivery to the ultimate purchaser or while it is in use,
2. The use of the vehicle after such device or element of design has been removed or rendered inoperative by any person.

Among those acts presumed to constitute tampering are the acts listed below:

1. Removal of engine noise-deadening panels, including cab or hood liners.
2. Removal of or rendering inoperative the engine speed governor so as to allow engine speed to exceed the manufacturer's specifications.
3. Removal of or rendering inoperative the fan clutch, including bypassing the control on any thermostatic fan drive to cause it to operate continuously.
4. Removal of the fan shroud.
5. Removal of or rendering inoperative exhaust system components, including exhaust pipe clamping.
6. Removal of air intake system components.

3.01 Safety Precautions	28
3.02 Engine Drive Belt Inspection	28
3.02.01 General Information	28
3.02.02 Inspection of the Belt and Pulley	28
3.02.03 Inspection of the Belt Tensioner	30

3. Engine

3.01 Safety Precautions

Safety Precautions in this section apply to all procedures within this group.

**DANGER:**

When working on the vehicle, shut down the engine or motor, set the parking brake, and chock the tires. Before working under the vehicle, always place jack stands under the frame rails to ensure the vehicle cannot drop. Failure to follow these steps could result in serious personal injury or death.

3.02 Engine Drive Belt Inspection

3.02.01 General Information

Worn or loose drive belts may cause engine overheating or loss of alternator power. Excessive tension, or too little tension on the belt may result in excessive and premature belt wear or accessory bearing failure. Serpentine belts are retained by a belt tensioner that requires no tension adjustment. Replace the drive belt if any conditions described below are found. To inspect a belt, gently twist it to view the belt sidewalls and bottom.

IMPORTANT: For EPDM rubber drive belts, do not rely on cracking as an indicator of belt wear. EPDM rubber drive belts resist cracking better than Neoprene belts. A better indicator of wear on EPDM belts is material loss.

3.02.02 Inspection of the Belt and Pulley

1. Check the belt contact surfaces for damage. See Fig.2, [Damaged Belts](#).

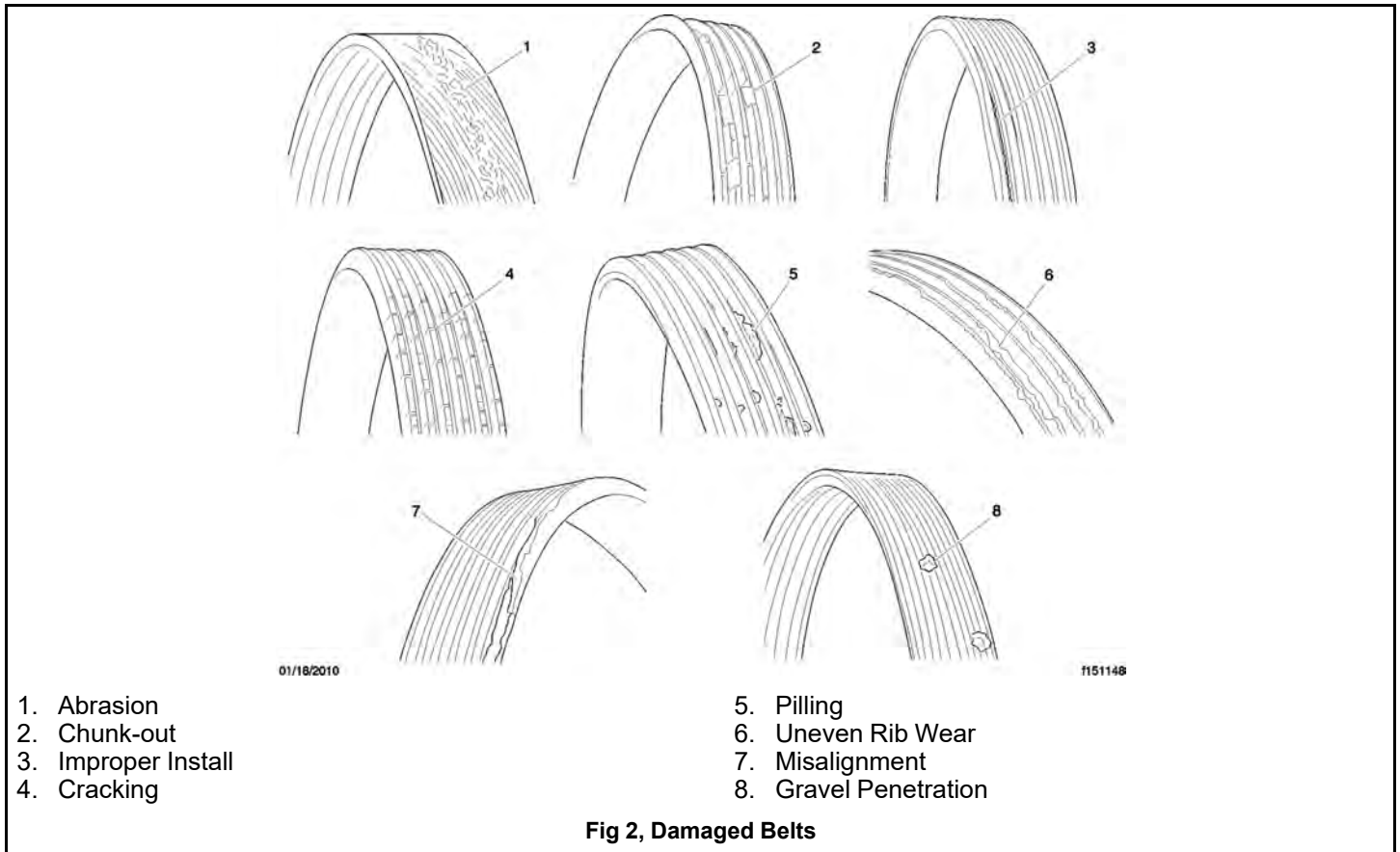

2. Inspect the belt for glazing. Glazing is represented by shiny sidewalls, and is caused by friction created when a loose belt slips in the pulleys. It can also be caused by oil or grease on the pulleys.
3. Check the belt for ply separation. Oil, grease, or belt dressing can cause the belt to fall apart in layers. Repair any oil or coolant leaks that are affecting the belts before replacing the drive belts. Do not use belt dressing on any belt.
4. Check the belt for a jagged or streaked sidewall. Jagged or streaked sidewalls are the result of foreign objects, such as sand or gravel in the pulley, or a rough pulley surface.
5. Check for tensile breaks (breaks in the cord body). Cuts in a belt are usually caused by foreign objects in the pulley, or by prying or forcing the belt during removal or installation.
6. Check for uneven ribs on serpentine belts. Foreign objects in the pulley will erode the undercord ribs, causing the belt to lose its gripping power.
7. For EPDM belts, check the belt for material loss, which causes the belt to seat further down in the pulley and to ride directly on the pulley tips. See Fig.3, [Six-Rib Serpentine Belt \(cross section view\)](#).

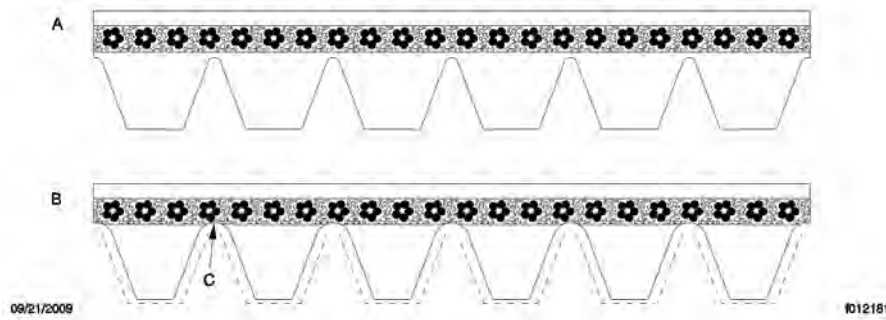

- 1. New Belt
- 2. Worn Belt

3. Material loss results in belt riding directly on pulley tips.

Fig 3, Six-Rib Serpentine Belt (cross section view)

- 8. For Neoprene belts, check the drive belts for cracks. Small irregular cracks are usually signs of an old belt.
- 9. Inspect the pulleys for excessive play or wobble. Excessive play or wobble indicates a failure of the pulley bearing. Check for belt squealing or squeaking. Replace the bearings as necessary.

NOTE: If it is difficult to distinguish the location of a supposed bearing noise, place a stethoscope on the component being checked, not the pulley, to isolate the area from outside interference.

- 10. Inspect all pulleys for foreign objects, oil, or grease in the grooves.

3.02.03 Inspection of the Belt Tensioner

Belt tension is automatically adjusted with a spring tensioner. See Fig. 4, [DD 13/15/16 Drive Belt Routing](#) and Fig. 5, [Cummins ISC/ISL Drive Belt Routing](#). Check that the tensioner is holding tension on the belt by inserting the end of a breaker bar in the 1/2-inch square hole on the forward face of the tensioner, and rotating the tensioner away from the belt. When the breaker bar is slowly released, the tensioner should return to its original position. The tensioner should rotate smoothly with no binding. If not, see [Principles of Operation, EPA10 Engine](#) in the *108SD Plus and 114SD Plus Workshop Manual* for replacement instructions.

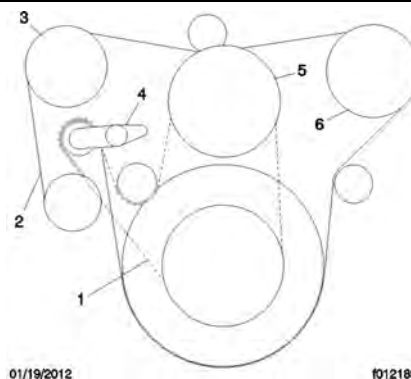

- 1. Front Belt
- 2. Rear Belt
- 3. AC Compressor

- 4. Spring Tensioner
- 5. Fan Clutch
- 6. Water Pump

Fig 4, DD 13/15/16 Drive Belt Routing

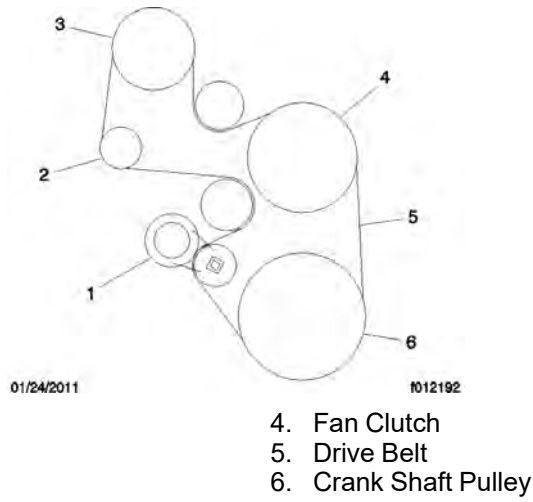

Fig 5, Cummins ISC/ISL Drive Belt Routing

4.01 Inspection and Replacement of the Air Cleaner Element 34

4. Air Intake

4.01 Inspection and Replacement of the Air Cleaner Element

Restriction of air flow through the air cleaner element is measured at the tap in the air cleaner outlet. Check the restriction indicator at the air cleaner or in the cab if the vehicle is equipped with a dash-mounted restriction gauge.

Vehicles may be equipped with either a manual-reset restriction indicator with graduations, as shown in Fig. 6, [Manual-Reset Air Restriction Indicator, Graduated](#), or a go/no-go restriction indicator without graduations, as shown in Fig. 7, [Manual-Reset Air Restriction Indicator, Go/No-Go](#).

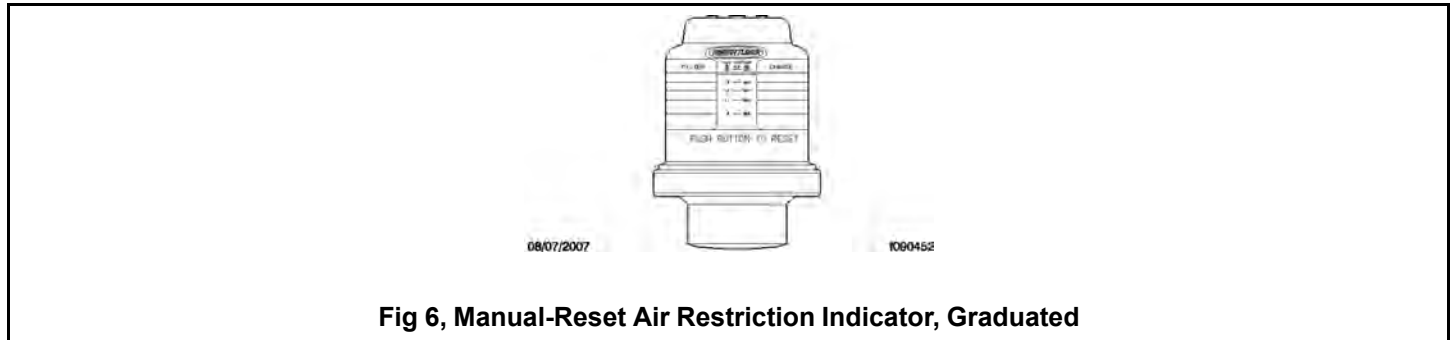

Fig 6, Manual-Reset Air Restriction Indicator, Graduated



Fig 7, Manual-Reset Air Restriction Indicator, Go/No-Go

1. Inspect the air restriction indicator to see if air restriction equals or exceeds the maximum allowable restriction. For instructions, see the *108SD Plus and 114SD Plus Driver's Manual*.



NOTICE:

Do not use aftermarket air-cleaner elements. Aftermarket air-cleaner elements may not seal the housing correctly, which can lead to engine damage and potentially the loss of warranty. When replacing an air-cleaner element, use only the part listed in PartsPro for the serial number of the vehicle.

2. If necessary, replace the air cleaner element. For air cleaner element replacement instructions, see [Removal of the Air Intake Duct](#) in the *108SD Plus and 114SD Plus Workshop Manual*.
3. Inspect the air cleaner housing for cracks, leaks, or any other damage. If the air cleaner housing or element is damaged, replace it.
4. Reset the air restriction indicator.

5. Each time the air cleaner housing is replaced, perform the procedures, see [General Information](#) in the *108SD Plus and 114SD Plus Workshop Manual*.

5.01 Safety Precautions 38

5.02 Inspection of the Air Compressor 38

5. Air Compressor

5.01 Safety Precautions

Safety Precautions in this section apply to all procedures within this group.



DANGER:

When working on the vehicle, shut down the engine or motor, set the parking brake, and chock the tires. Before working under the vehicle, always place jack stands under the frame rails to ensure the vehicle cannot drop. Failure to follow these steps could result in serious personal injury or death.

5.02 Inspection of the Air Compressor

1. Inspect the air compressor intake hoses and connections at the air intake and air compressor for physical damage. If needed, change the hoses, and/or tighten or replace the connections.
2. Inspect the coolant supply and return lines for tight connections. Tighten the connections and replace the lines and fasteners if needed.
3. For the air governor, inspect the piping and connections for leaks. Replace gaskets and faulty components as needed.

6.01 Safety Precautions	40
6.02 Checking the Alternator, Battery, and Starter	40

6. Alternators and Starters

6.01 Safety Precautions

Safety Precautions in this section apply to all procedures within this group.

**DANGER:**

When working on the vehicle, shut down the engine or motor, set the parking brake, and chock the tires. Before working under the vehicle, always place jack stands under the frame rails to ensure the vehicle cannot drop. Failure to follow these steps could result in serious personal injury or death.

6.02 Checking the Alternator, Battery, and Starter

**WARNING:**

Batteries release explosive gas as a by-product of their chemical activity. Do not smoke when working around batteries. Put out all flames and remove any source of sparks or intense heat. Make sure the battery compartment is completely vented before disconnecting or connecting the battery cables.

Battery acid is extremely harmful if splashed in the eyes or on the skin. Always wear a face shield and protective clothing when working around batteries.

Damaged, chafed, or kinked wiring can cause electrical short-circuits and lead to fires, causing property damage, injury, or death. Clean, inspect, and maintain wiring and connections carefully.

1. Park the vehicle on a level surface. Apply the parking brakes, and chock the rear tires.
2. Disconnect the batteries.
3. Check the tightness of the alternator bracket fasteners; tighten the fasteners as needed. For torque values, see [General Information](#) in the *108SD Plus and 114SD Plus Workshop Manual*.
4. See [Principles of Operation, EPA10 Engine](#) for belt tension specifications. Check the alternator drive belt tension, using a tension gauge at the belt's longest span. Some engines are equipped with more than one alternator belt; check all of them for correct tension. Adjust the belt tension if necessary.

Engines equipped with a serpentine or poly-V belt have automatic belt tensioners, and do not require belt tension inspection.

5. Check that all electrical connections at the alternator and starter are clean. Clean and tighten all charging system electrical connections including the connections at the starter B terminal and ground terminal, and where the alternator charging cable terminates.

Trace and inspect all wiring and cables connected to:

- alternator
- starter and depopulation studs
- batteries
- magnetic switch
- cab
- jump-start studs
- battery isolation relays

- battery shutoff switches
6. Check wires and cables for wear, chafing, kinks, discolored insulation, or loose clamps or ties. Find the cause of any problems and repair, replace, and reroute wires and clamps as necessary.
 7. Check the alternator wiring for missing insulation, kinks, and heat damage. Replace or repair as needed.
 8. On the bundled cable that runs from the batteries to the starter, ensure that tie straps are installed at least every 12 inches (308 mm). Replace any missing tie straps, and add tie straps where spacing between them exceeds 12 inches (308 mm).
 9. Ensure that all cables have sufficient slack to allow for engine movement, and that there is no pressure on any wiring connectors.
 10. If any convoluted tubing is damaged, check the wiring inside it. Replace any damaged or missing convoluted tubing.
 11. Clean the cable connector terminals with a wire brush. See [General Description, Wiring](#) in the *108SD Plus and 114SD Plus Workshop Manual* for troubleshooting instructions, and for adjustment, repair, or replacement instructions.
 - 11.a Clean and tighten the battery ground cable, terminal, and clamps.
 - 11.b Inspect the retainer assembly (or battery hold-downs) and the battery box. Replace worn or damaged parts. Remove any corrosion with a wire brush, and wash with a weak solution of baking soda and water. Rinse with clean water and dry. To prevent rusting, paint the retainer assembly.
 - 11.c Check for and remove any foreign objects such as stones, bolts, or nuts, from the battery box.
 - 11.d After cleaning, connect the cables to the batteries, and tighten them to the torque specifications listed on the battery, generally 10 to 15 lbf·ft (14 to 20 N·m).
 - 11.e Coat the battery terminals with dielectric grease.
 12. Check the terminals on the battery shut-off switch and the magnetic switch. Make sure the terminal connections are clean and tight. Coat the terminal connections with dielectric red enamel after cleaning.

7.01 Safety Precautions	44
7.02 Inspection of the Radiator Cap	44
7.03 Radiator Pressure Flush and Coolant Change	45
7.04 Fan Drive Inspecting (Noise Emission Control)	45
7.04.01 BorgWarner eViscous Fan Clutch.....	45
7.04.02 Horton Advantage® Fan Clutch.....	46
7.04.03 Kysor K22RA, K22FA, and K26RA Fan Drives	46
7.04.04 Horton DriveMaster® Fan Clutch.....	46

7. Engine Cooling/Radiator

7.01 Safety Precautions

Safety Precautions in this section apply to all procedures within this group.

**DANGER:**

When working on the vehicle, shut down the engine or motor, set the parking brake, and chock the tires. Before working under the vehicle, always place jack stands under the frame rails to ensure the vehicle cannot drop.

7.02 Inspection of the Radiator Cap

**WARNING:**

Do not remove or loosen the radiator cap until the engine and cooling system have completely cooled. Use extreme care when removing the cap. A sudden release of pressure from removing the cap prior to the system cooling can result in a surge of scalding coolant that could cause serious personal injury.

**NOTICE:**

The radiator cap currently installed may not be the same one installed when the vehicle was built. If the radiator cap must be replaced, make sure that it is the correct cap for the cooling system of the vehicle. Because the radiator cap pressure rating affects the operating temperature of the engine, installing an improperly rated radiator cap may have adverse effects on the cooling system, and engine operating temperatures. This could cause premature engine wear or damage.

- Using the Snap-On tool radiator-cap tester shown in Table 12, [Snap-On Tool for Pressure Relief Cap Test](#), check the pressure relief cap to see if it maintains pressure to within 10% of the pressure rating marked on the cap. If it does not, replace the cap. Make sure that the replacement radiator cap is correctly rated for the cooling system of the vehicle. Use the recommended tool in Table 12, [Snap-On Tool for Pressure Relief Cap Test](#).

Tool	Part Number
Radiator-Cap Tester	TA53

- There is a second valve in the radiator cap that opens under vacuum. This prevents the collapse of hoses and other parts that are not internally supported when the system cools. Inspect the vacuum-relief valve to be sure it is not stuck.
- Make sure that the cap seals properly on the coolant filler neck seat, and that the radiator cap gasket is not damaged. On vehicles with screw-on caps with O-rings, make sure that the O-ring is not cracked or deteriorated. Replace the cap if the gasket shows deterioration or damage.

7.03 Radiator Pressure Flush and Coolant Change

NOTE: For additional instructions on cleaning and flushing the cooling system, see the engine maintenance and operation manual.

**WARNING:**

Drain the coolant only when the coolant and engine are cool. Draining it when these are hot could cause severe personal injury due to scalding.

1. Drain the radiator, as follows.
 - 1.a Place a large container under the radiator.
 - 1.b Remove the surge tank cap.
 - 1.c Open the petcock at the bottom of the radiator to drain the engine coolant.
2. Disconnect the radiator inlet and outlet hose connections.
3. Flush the radiator, as follows.
 - 3.a Attach a flushing gun nozzle to the radiator outlet.
 - 3.b Add water to the radiator until it is full.

**NOTICE:**

When flushing the radiator, do not apply more than 20 psi (138 kPa) air pressure. Excessive pressure can damage the radiator or heater core.

- 3.c Apply no more than 20 psi (138 kPa) air pressure intermittently to help dislodge sediment buildup in the core.
4. Drain the radiator, then flush the radiator until clean water flows from it. Remove the flushing gun.
5. Close the petcock.
6. Using clamps, connect the hoses to the radiator. Torque the clamps 33 to 38 lbf·in (370 to 430 N·cm).

IMPORTANT: The coolant capacity varies depending on the engine and accessory installation. After servicing the cooling system, always verify that the coolant level is between the MIN and MAX lines on the surge tank.

7. Fill the radiator with coolant. Refer to the engine manufacturer's service literature for specific coolant information.

7.04 Fan Drive Inspecting (Noise Emission Control)

7.04.01 BorgWarner eViscous Fan Clutch

1. Check the fan for loose rivets and missing weights. Check for bent, cracked, or missing blades. Tighten loose components. Replace the fan drive if necessary.

2. Check for adequate clearance between the fan and the fan shroud or other engine compartment components in both the engaged mode and the disengaged mode. If the clearance is not adequate, make the necessary adjustments.
3. Check the fan belt condition and the belt alignment. Replace or correct as necessary.
4. Check for harness abrasion.
5. Check for fluid leaks from the clutch body.

7.04.02 Horton Advantage® Fan Clutch

1. Check the fan for loose rivets and missing weights. Check for bent, cracked, or missing blades. Tighten loose components. Replace the fan drive if necessary.
2. Check for adequate clearance between the fan and the fan shroud or other engine compartment components in both the engaged mode and the disengaged mode. If the clearance is not adequate, make the necessary adjustments.

NOTE: Horton HT650 Fan Drive Check for friction facing wear condition. Replace when worn to 1/16-inch (1.5-mm) thick, when oil is spotted, or when burn marks are visible.

3. Check the fan belt condition and the belt alignment. Replace or correct as necessary.

7.04.03 Kysor K22RA, K22FA, and K26RA Fan Drives

1. Check the fan for missing, cracked, chipped, or damaged blades. Tighten loose components. Replace damaged fans if necessary.
2. Check for adequate clearance around the fan. The fan should be centered in the shroud to prevent contact between the fan and the shroud.
3. Check the fan belt for proper alignment and condition. If the belt is worn or frayed, replace the belt.
4. Verify the fan drive engagement. With the engine and ignition key switch off, apply at least 90 psi (620 kPa) to the clutch; the fan should rotate freely. Remove air pressure from the clutch and the fan should not rotate.
5. With the fan drive disengaged, check for air leaks at the front of the clutch and between the clutch and the drive hub. If an air leak is detected, the clutch seals and hub must be inspected for wear or damage. If necessary, the seals of the clutch can be replaced with a Kysor rebuild kit. If inspection of the hub indicates excessive wear, rebuild the hub using a hub rebuild kit from Kysor.
6. Any time the clutch is removed for repair or replacement, the pulley hub and bearings should be inspected for play, roughness, or damage. Hub bearing service kits are available from Kysor.
7. Check the lining with the System Alert Tool™. If the lining is worn, install the appropriate lining kit. A lining that is prematurely worn is caused by control air supply problems. Inspect and correct the vehicle control system before placing the vehicle back in service.
8. Check the air line entry and routing at the front or rear of the fan drive. Look for cracked, damaged, or improperly routed air lines. Make sure the connections are tight and that there are no air leaks.
9. Check the electrical connections at the solenoid valve. The solenoid valve is part of the air module unit (AMU), which is located on the rear crossmember. Check the exhaust port for restrictions. If a restriction is found, clear it.

7.04.04 Horton DriveMaster® Fan Clutch

NOTE: If any part of the fan clutch needs to be repaired or replaced after performing the checks below, see [Troubleshooting, Cooling System](#) in the *108SD Plus and 114SD Plus Workshop Manual*.

1. Disconnect the batteries at the negative terminals. Drain all air from the air system. If equipped with an air starter, drain the air starter reservoir.

**WARNING:**

Make sure the batteries are disconnected before checking the fan clutch. If the engine starts during this procedure, the fan could engage, which could result in serious personal injury.

2. Inspect the electrical connections and wires to the fan clutch solenoid. Secure the connection if loose; replace wires and connectors if damaged.
3. Clean the fan clutch air solenoid valve filter, if equipped.
 - 3.a Unscrew the fan clutch solenoid valve air filter assembly, and remove the filter element.
 - 3.b Clean the filter element with cleaning solvent.
 - 3.c Using a clean, lint-free cloth, wipe off any excess solvent.
 - 3.d Reassemble the clutch valve solenoid air filter assembly, and install it on the vehicle.
4. Visually check the fan for bent, cracked, or damaged blades. Replace if damaged. Check for adequate clearance between the fan and other components.
5. Check the fan belt for wear, tension, and alignment. Correct, if necessary.
6. Check for wear on the friction facing. Replace the friction facing if it is worn to a 3/16-inch (4.8-mm) thickness or less. Also check the facing for signs of oil contamination or burn marks. If evidence of oil or burn marks are found, replace the friction facing.
7. Connect the battery cables. Start the engine, and charge the air system to 120 psi (827 kPa). Manually engage and disengage the fan clutch.

Check the fan and the fan clutch from a distance. Look for vibration, fan blade contact, fan clutch slippage, and overall fan clutch operation.

If the fan clutch does not operate correctly, see [Troubleshooting, Cooling System](#) in the *108SD Plus and 114SD Plus Workshop Manual* for troubleshooting and repair procedures.

8. With the air system charged to 120 psi (827 kPa), check the fan clutch for audible air leaks, using a suitable listening device.

Check at the solenoid valve, the air filter assembly, and the air hoses and fittings. See Fig.

8, [Checking for Air Leaks \(Horton DriveMaster\)](#). Using a wet finger or a soapy water solution, check for a leak in the same areas.

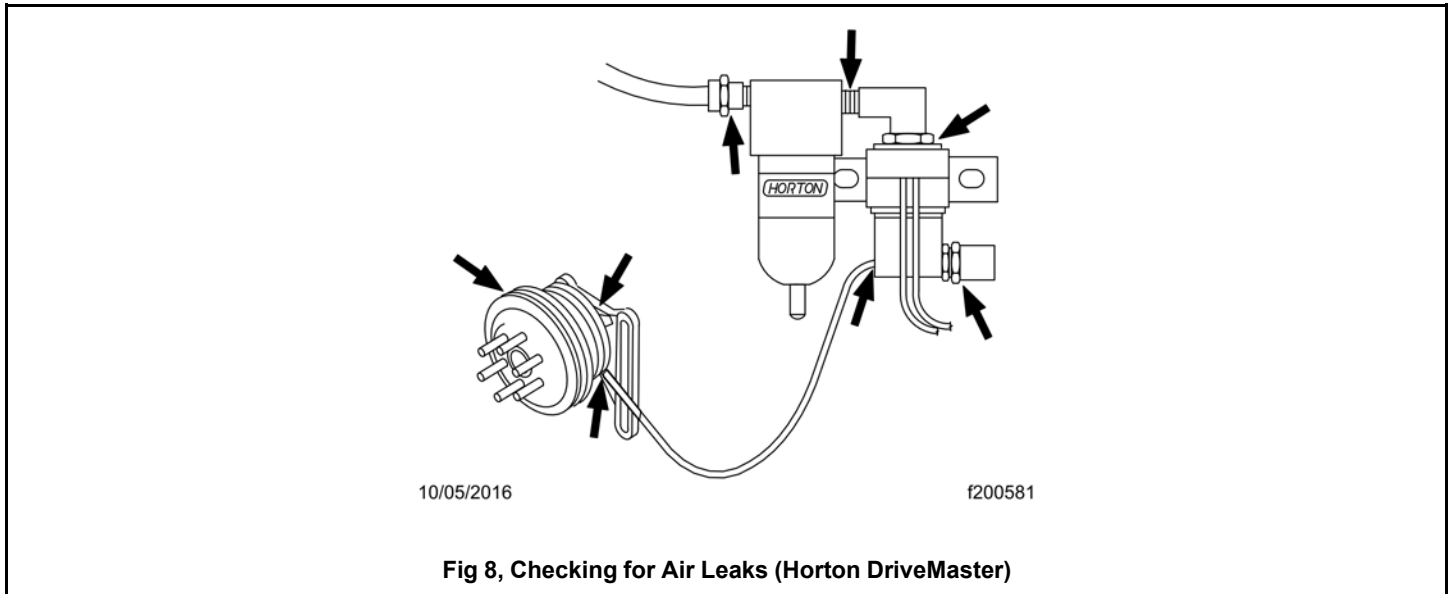

9. If a leak is detected, remove the fan blade. Install a new seal kit. See [Troubleshooting, Cooling System](#) in the *108SD Plus and 114SD Plus Workshop Manual* for repair procedures.
10. Check the fan drive for discoloration or any other signs of slipping or overheating.

NOTE: The fan clutch may slip if the air supply pressure is below 70 psi (483 kPa) or if there is a leak inside the fan clutch. Any leak must be remedied.

11. Check the fan clutch bearings.
 - 11.a Turn the fan in both directions and feel for worn hub bearings.
 - 11.b If possible, remove the drive belt and check for worn sheave bearings by turning the sheave in both directions.
 - 11.c If either the hub or sheave bearings are worn, replace them, using a Horton DriveMaster Super Kit.

For instructions and kit part number, see [Troubleshooting, Cooling System](#) in the *108SD Plus and 114SD Plus Workshop Manual*.

8.01 Safety Precautions	50
8.02 Eaton Fuller Clutch Release Bearing Lubrication	50
8.03 Clutch Hydraulic Fluid Changing.....	51
8.03.01 Flushing	51
8.03.02 Bleeding the Clutch	54
8.04 Clutch Adjusting, Manually Adjusted Clutches	55

8. Clutch

8.01 Safety Precautions

Safety Precautions in this section apply to all procedures within this group.

**DANGER:**

When working on the vehicle, shut down the engine or motor, set the parking brake, and chock the tires. Before working under the vehicle, always place jack stands under the frame rails to ensure the vehicle cannot drop. Failure to follow these steps could result in serious personal injury or death.

8.02 Eaton Fuller Clutch Release Bearing Lubrication

The standard clutch release bearing is sealed, and does not require lubrication. If the vehicle is not equipped with a maintenance-free sealed clutch release bearing, lubricate the bearing as follows:

1. Park the vehicle on a level surface, shut down the engine, and set the parking brake. Chock the tires.
2. Place a large drain pan under the transmission.
3. Remove the clutch inspection plate.

NOTE: Some clutch release bearings are equipped with a lubrication extension that extends outside of the clutch housing. It is not necessary to remove the clutch inspection plate when the lubrication extension is used.

NOTE: For lubricating the release bearing, Eaton Fuller recommends a lithium-base high-temperature grease that meets the NLGI grade one or two specification.

4. Wipe the dirt away from the grease fitting. See Fig.9, [Release Bearing Grease Fitting](#). See a low-pressure-type grease gun equipped with the recommended grease, and lubricate the bearing until excess grease purges from the rear of the release bearing (toward the transmission).

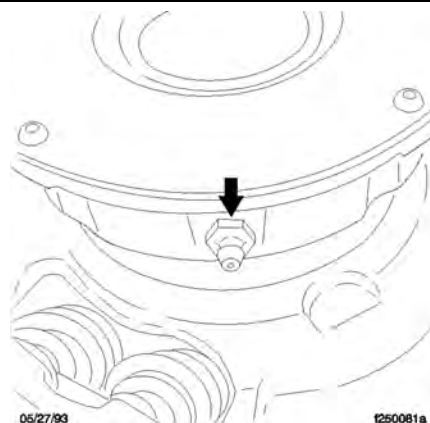
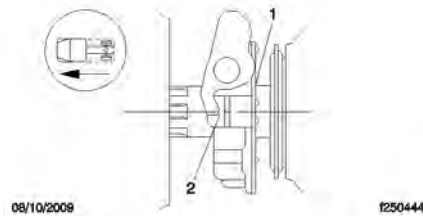

Fig 9, Release Bearing Grease Fitting

**NOTICE:**

Do not over-lubricate the clutch release bearing. Over-lubrication could contaminate the clutch internally, causing clutch slippage and premature failure. Do not use chassis grease or multipurpose lubricants.

- Wipe off excess grease and apply it to both the yoke finger and sleeve bushing contact points. See Fig. 10, [Grease the Contact Points](#).



1. Sleeve Bushing Contact Point

2. Yoke Finger Contact Points

Fig 10, Grease the Contact Points

- Install the clutch inspection plate.
- Remove the chocks.

8.03 Clutch Hydraulic Fluid Changing

8.03.01 Flushing

Replace the clutch hydraulic fluid every two years to ensure clutch function is reliable and correct. Use the procedures below. Fluid replacement must be done at an authorized Freightliner service facility.

- Park the vehicle on a level surface. Apply the parking brakes, and chock the front and rear tires.
- Raise the hood.

**WARNING:**

Clutch hydraulic fluid (DOT 4 brake fluid) is hazardous. It may be a skin irritant and can cause blindness if it gets in your eyes. Always wear safety glasses when handling clutch hydraulic fluid or bleeding hydraulic lines. If you get clutch hydraulic fluid on your skin, wash it off as soon as possible.

- Prepare the pressure bleeding equipment according to the manufacturer's instructions. Use DOT 4 brake fluid. Pressurize the bleed adaptor to 15 psi (103 kPa).

**CAUTION:**

Do not spill clutch hydraulic fluid (DOT 4 brake fluid) on the cab paint. Clean it off immediately if any is spilled. DOT 4 brake fluid can damage paint.

4. Remove the reservoir lid and install the pressure bleed adaptor on the reservoir.
5. Pressurize the reservoir, filling the system. Open the bleed valve on the bleed tank of the adaptor.

NOTE: A pressure bleeder hose (J-29532) and a bleed adaptor (J-35798) for the fluid reservoir are available through SPX Kent-Moore Tools and may be used to complete the following procedure. To order these parts, call Kent-Moore at 1-800-328-6657.

6. Flush the hydraulic system. See Fig. 11, [Clutch Secondary Cylinder](#).

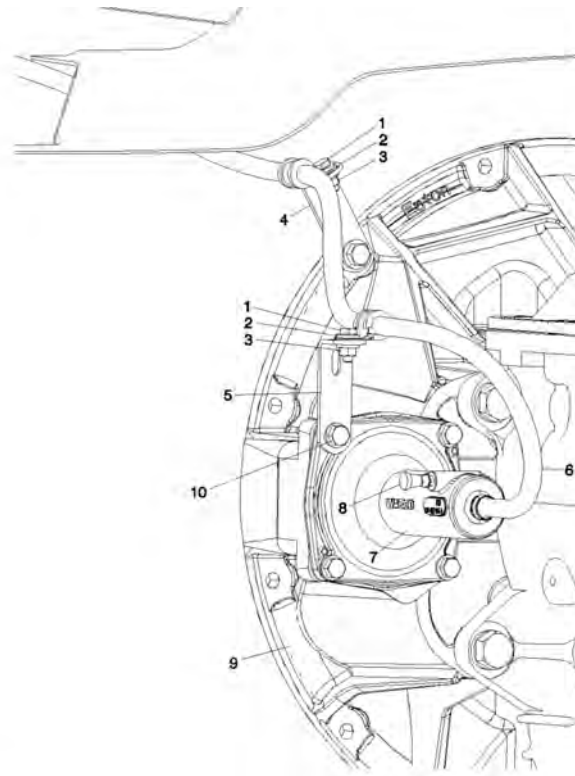

- | | |
|--|--|
| 1. Clamp-Mounting Bolt, 1/4–20 | 6. Hydraulic Hose |
| 2. Plated Steel Washer | 7. Secondary Cylinder |
| 3. Locknut, 1/4–20 | 8. Bleed Valve |
| 4. Bell Housing Standoff Bracket | 9. Bell Housing |
| 5. Secondary Cylinder Standoff Bracket | 10. Secondary Cylinder Mounting Capscrew, M8 |

Fig 11, Clutch Secondary Cylinder

- 6.a Open the bleed screw on the secondary cylinder.
- 6.b Using a drain pan or other suitable container, collect the fluid that drains from the secondary cylinder bleed valve, at least 0.5 quarts (0.5 liters).
- 6.c When all the old fluid has passed through the system and only new, clean fluid is coming out, close the bleed screw.
7. Check the fluid level in the reservoir and bleed the system according to the procedures under the heading "Bleeding the Clutch." See Fig. 12, [Clutch Main Cylinder](#).

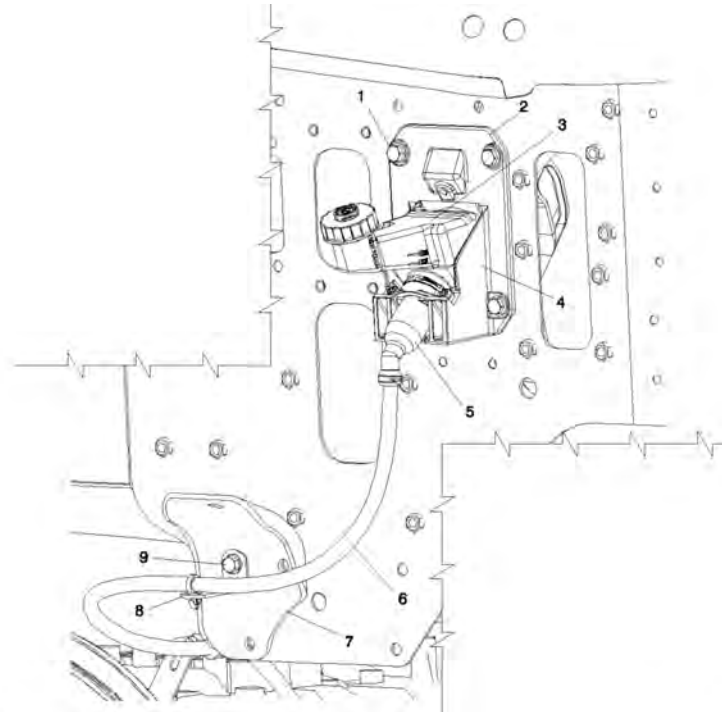

12/11/2001

P250581

- | | |
|------------------------------|-----------------------|
| 1. M8 Capscrew and Washer | 6. Hydraulic Hose |
| 2. Pedal Unit Mounting Plate | 7. Cup Bracket |
| 3. Reservoir | 8. Standoff Bracket |
| 4. Pedal Unit | 9. Mounting Bolt, M10 |
| 5. Main Cylinder | |

Fig 12, Clutch Main Cylinder

8.03.02 Bleeding the Clutch

1. Remove the cap from the bleed valve. Install a transparent drain hose on the bleed valve of the secondary cylinder.
2. Open the secondary cylinder bleed screw. Observe the flow of clutch hydraulic fluid through the drain hose. When bubbles no longer appear in the fluid, close the secondary cylinder bleed screw.
3. Disconnect the transparent hose. Tighten the bleed screw 88 lbf-in (1000 N-cm) and install the cap on the secondary cylinder bleed valve.
4. Close the valve on the bleed tank of the pressure bleed adaptor. Remove the pressure bleed adaptor.
5. Check the fluid level in the reservoir. If necessary, add or remove clutch hydraulic fluid to bring the fluid level to the MAX line. Install the reservoir lid.

**CAUTION:**

When removing fluid from the reservoir, use a clean tool that is used only for brake fluid. Using a tool contaminated with oil or chemical residue will destroy hydraulic system parts and cause the system to malfunction.

6. Depress the clutch pedal a few times. There should be resistance over the full pedal stroke.

7. Check the entire system for leaks. Tighten the connections between the components if necessary. Check the fluid level in the reservoir again.
8. Make sure the reservoir lid is tight.
9. Lower the hood and remove the chocks from the front and rear tires.

8.04 Clutch Adjusting, Manually Adjusted Clutches

NOTE: This procedure is only required for vehicles equipped with non-synchronized transmissions and manually adjusted clutches.

Release bearing travel is the clearance between the rear surface of the release bearing housing and the forward surface of the clutch brake disc. This distance must be maintained between 1/2 and 9/16 inch (12.7 and 14.3 mm).

1. Remove the clutch inspection cover from the bell housing. See Fig. 13, [View from Underneath the Vehicle](#).

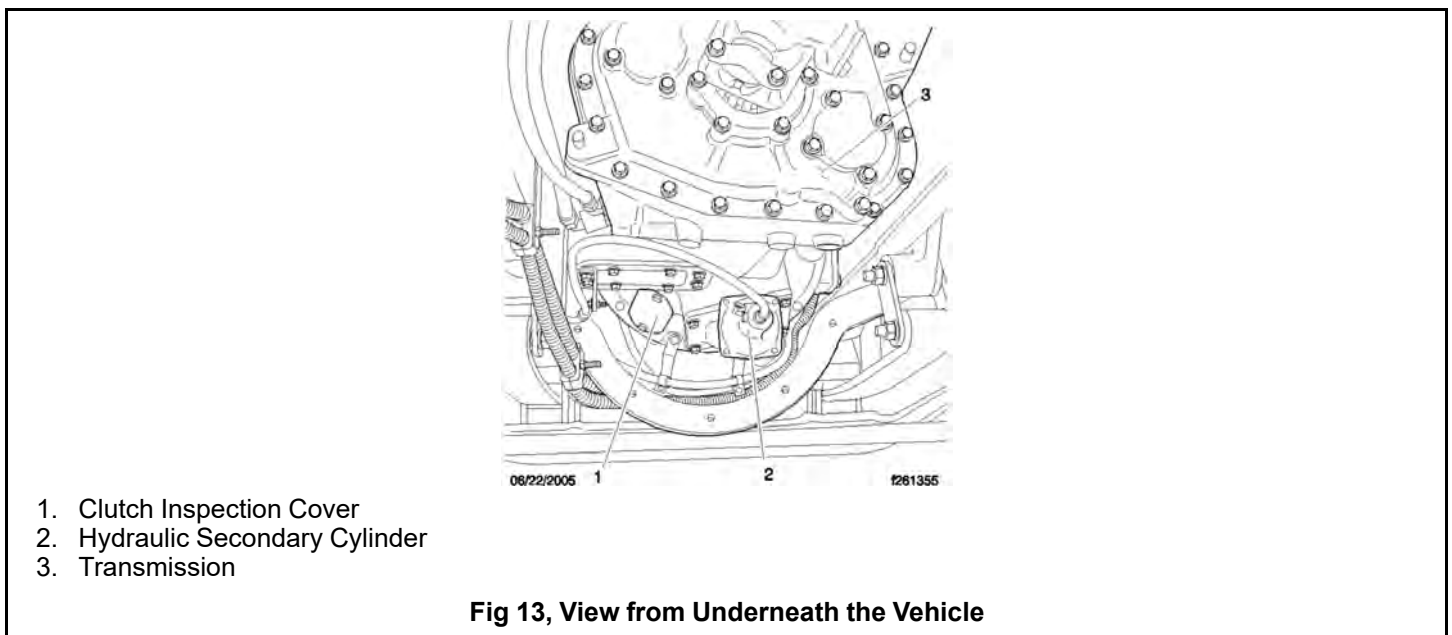

Fig 13, View from Underneath the Vehicle

2. Slide the clutch brake tight against the transmission input-shaft bearing cap.

IMPORTANT: Release bearing travel tool A02-12419-000 is available through the PDCs. The fork at one end of the tool has green tape on it, and has two 0.50-inch (12.7-mm) diameter tips; the fork at the other end has blue tape on it, and has 0.56-inch (14.3-mm) diameter tips. See Fig. 14,, page 56.

3. Measure the release bearing travel. See Fig. 15, [Release Bearing Travel Measurement](#) for the correct dimension to measure. Using both ends of the release bearing travel tool, check this gap as follows:
 - Position the tool so that the legs of the fork at the blue 0.56-inch (14.3-mm) end straddle the transmission input shaft. If the tool fits loosely, the gap is too wide and adjustment is needed. Go to the next step.
 - If the blue 0.56-inch (14.3-mm) end can't be inserted in the gap, then try to insert the green 0.50-inch (12.7-mm) end.
 - If the green end of the tool can't be inserted in the gap, adjustment is needed. Go to the next step.
 - If the green end of the tool fits — snugly or loosely — then no adjustment is needed. Nothing more needs to be done. Install the clutch inspection cover.



A. Green End (0.50 inch or 12.7 mm)

B. Blue End (0.56 inch or 14.3 mm)

Fig 14, Release Bearing Travel Tool A02-12419-000

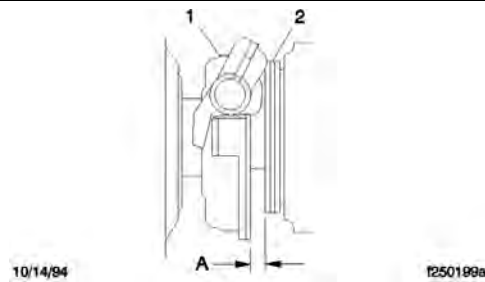

A. Clearance between release bearing housing and clutch brake must be 1/2 to 9/16 inch (12.7 to 14.3 mm).

1. Release Bearing Housing
2. Clutch Brake

Fig 15, Release Bearing Travel Measurement

4. Turn the engine flywheel until the lockstrap is aligned with the clutch inspection-cover opening.
5. Release the clutch by depressing the pedal. Block the pedal in the released position, or have someone assist you by holding the pedal down during the adjustment procedure.

NOTE: An open-end wrench is not recommended for the following step.

6. Adjust the clutch, using a 5/8-inch box-end or socket wrench on the adjustment bolt. See Fig. 16, [Adjustment with Kwik-Adjust \(shown with bell housing removed\)](#).

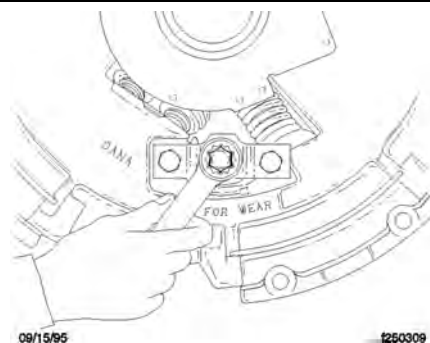

Fig 16, Adjustment with Kwik-Adjust (shown with bell housing removed)

- 6.a Insert the 5/8-inch box-end or socket wrench through the inspection cover opening.
- 6.b To begin the adjustment, release the adjustment bolt by pressing down on the bolt head.

NOTE: On Easy-Pedal 2000 clutches, each complete turn of the adjustment bolt represents about 0.125 inch (3 mm) of release bearing movement. On earlier Easy-Pedal models, each complete turn of the adjustment bolt represents about 0.02 inch (0.5 mm) of release bearing movement. Normal wear increases the gap between the release bearing and the transmission.

- 6.c *To decrease the gap* : If clearance between the release bearing housing and the clutch brake is *more than* 9/16 inch (14.3 mm), turn the adjustment bolt clockwise (the release bearing moves toward the transmission).
To increase the gap : If clearance between the release bearing housing and the clutch brake is *less than* 1/2 inch (12.7 mm), turn the adjustment bolt counterclockwise (the release bearing moves toward the engine).
- 6.d When the adjustment is complete, make sure the adjustment bolt is locked (pulled up flush with the mounting bolts).
7. After adjusting, release the pedal and check the clearance between the release bearing housing and the clutch brake. When the adjustment is correct, the green end of the tool should go in and the blue should not (clearance of 1/2 to 9/16 inch, or 12.7 to 14.3 mm).
8. Install the clutch inspection cover.

9.01 Safety Precautions 60

9.02 Detroit® Automated Transmission Fluid Change and Magnetic Plug Cleaning 60

9.03 Detroit® Automated Transmission Fluid Level Inspection 61

9.04 Transmission Fluid Level Checking..... 62

 9.04.01 Eaton Fuller Manual and Automated..... 62

 9.04.02 Allison 64

9.05 Eaton Fuller Transmission Fluid Changing and Magnetic Plug Cleaning 66

 9.05.01 Draining 66

 9.05.02 Filling 66

9.06 Allison and Eaton Fuller Transmission Breather Checking 69

9.07 Eaton Fuller Transmission Air Filter/Regulator Element Cleaning 69

9.08 Allison Transmission Fluid and Filter Changing 71

 9.08.01 General information 71

 9.08.02 MD and HD Series 71

9. Transmission

9.01 Safety Precautions

Safety Precautions in this section apply to all procedures within this group.



DANGER:

When working on the vehicle, shut down the engine or motor, set the parking brake, and chock the tires. Before working under the vehicle, always place jack stands under the frame rails to ensure the vehicle cannot drop. Failure to follow these steps could result in serious personal injury or death.

9.02 Detroit® Automated Transmission Fluid Change and Magnetic Plug Cleaning



NOTICE:

Operating a transmission with the fluid level higher or lower than recommended can result in transmission damage. Do not overfill the transmission. Overfilling will force fluid out of the case through the main shaft openings.

Do not mix types or brands of fluid, because of possible incompatibility. Do not use fluid additives, friction modifiers, or extreme-pressure gear fluids.

IMPORTANT: Drain the transmission when the fluid is warm. If not already warm, run the engine until the transmission fluid reaches operating temperature. Shift the transmission to neutral (N) and shut down the engine.

1. Park the vehicle on a level surface, shut down the engine, and set the parking brake. Chock the tires.
2. Place a large drain pan under the transmission.
3. Clean the area around the fill plug, then remove it from the side of the gear case. Remove the drain plug from the bottom of the case. See Fig.17, [Drain and Fill Plugs, Detroit Automated Transmissions](#).



03/31/2014

f270167

1. Drain Plug

2. Fill Plug

Fig 17, Drain and Fill Plugs, Detroit Automated Transmissions

4. Clean the fill plug and the drain plug.

5. Install a new seal on the drain plug, then install the plug and tighten it 45 lbf·ft (61 N·m).

**NOTICE:**

Detroit transmissions use synthetic lubricant that meets specific requirements. To see a list of approved lubricants and information to identify which transmissions they can be used with, see the Transmission Fluid Service Information brochure at <http://dtna.info/DT12FluidsManual>.

6. Add fluid until it is level with the lower edge of the fill opening; see Fig. 18, [Checking Transmission Fluid Level](#). See the Detroit Transmission Fluid Service Information brochure at <http://dtna.info/DT12FluidsManual>, for identifying the transmission type, estimated transmission fluid capacities, and applicable fluid specifications.

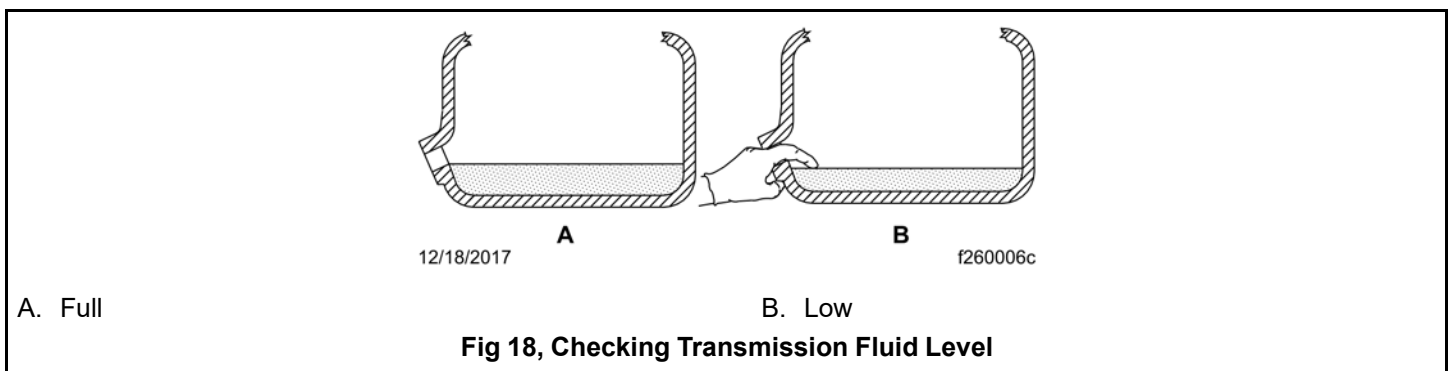

NOTE: In all cases, the correct fluid level is established by checking at the fill opening.

7. Operate the engine for five minutes after filling the transmission, then check the fluid level again.
8. Install a new seal on the fill plug, then install the plug and tighten 45 lbf·ft (61 N·m).
9. Operate the vehicle to check for correct operation.

9.03 Detroit® Automated Transmission Fluid Level Inspection

**NOTICE:**

Operating a transmission with the fluid level higher or lower than recommended can result in transmission damage. Do not overfill the transmission. Overfilling will force fluid out of the case through the main shaft openings.

Do not mix types or brands of fluid, because of possible incompatibility. Do not use fluid additives, friction modifiers, or extreme-pressure gear fluids.

With the transmission at operating temperature, and the vehicle on a level surface, check the fluid level in the transmission.

1. Clean the area around the fill plug, then remove it from the side of the gear case.
2. Using your finger or a bent pipe cleaner, see if the fluid is level with the fill opening. See Fig. 19, [Checking Transmission Fluid Level](#).

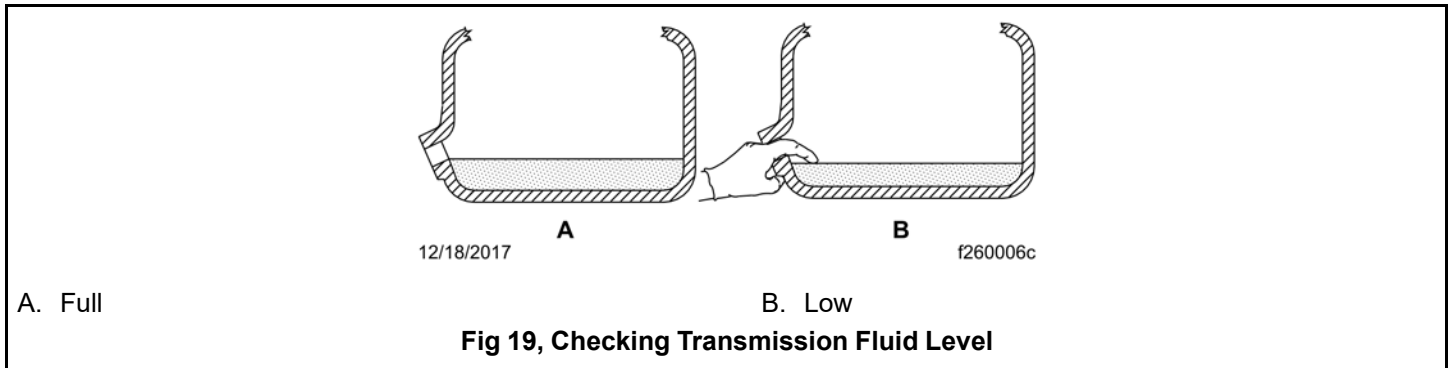

3. If the fluid level is low, check the transmission for leaks, and correct as needed.

**NOTICE:**

Detroit transmissions use synthetic lubricant that meets specific requirements. To see a list of approved lubricants and information to identify which transmissions they can be used with, see the Transmission Fluid Service Information brochure at <http://dtna.info/DT12FluidsManual>.

4. If needed, add the recommended fluid until it is level with the lower edge of the fill opening. See the Transmission Fluid Service Information brochure at <http://dtna.info/DT12FluidsManual> for approved transmission lubricants.
5. Clean the fill plug and install a new seal on it. Install the plug in the side of the gear case, then tighten 45 lbf·ft (61 N·m).

9.04 Transmission Fluid Level Checking

9.04.01 Eaton Fuller Manual and Automated

**NOTICE:**

Operating a transmission with the fluid level higher or lower than recommended can result in transmission damage. Do not overfill the transmission. Overfilling will force fluid out of the case through the main shaft openings. Fluid overflow may also drain onto the clutch or clutch brake, causing additional problems.

Do not mix types and brands of fluid, because of possible incompatibility. Do not use fluid additives, friction modifiers, extreme-pressure gear fluids, or multiviscosity lubricants.

1. Park the vehicle on a level surface, apply the parking brakes, and chock the tires.
2. Check the oil level in the transmission as follows.
 - 2.a Clean the area around the fill plug, then remove the plug from the side of the case.
 - 2.b Using your finger or a bent pipe cleaner, see if the oil is level with the lower edge of the fill opening. See Fig. 20, [Checking Transmission Fluid Level](#).

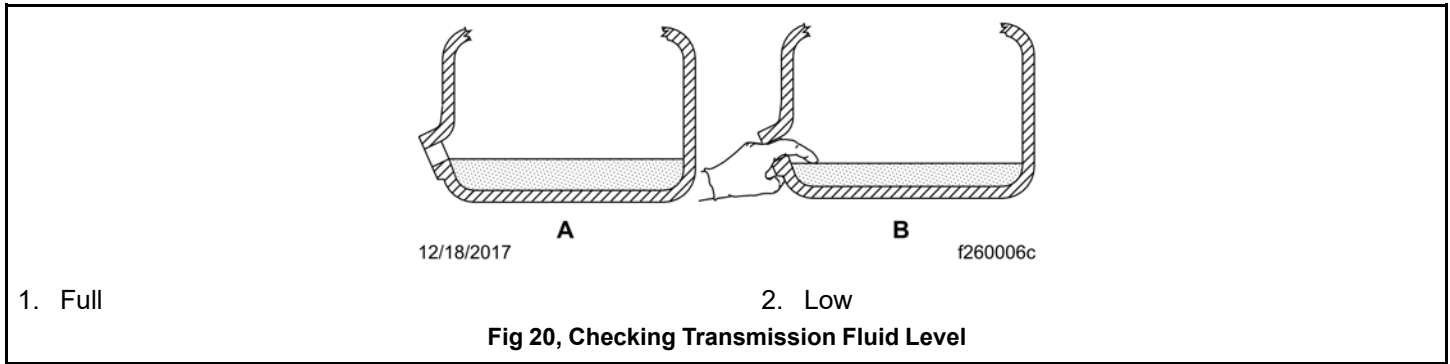

1. Full

2. Low

Fig 20, Checking Transmission Fluid Level

- If needed, fill the transmission with oil until level with the lower edge of the fill opening. For approved lubricants, see Table 13, [Eaton Approved Manual Transmission Lubricants](#) (manual transmissions) or Table 14, [Eaton Approved Automated Transmission Lubricants](#) (automated transmissions). For more information and a complete listing of approved lubricants, refer to the Eaton website: www.roadranger.com.

Lubricant Type ¹	Temperature: °F (°C)	SAE Viscosity
Synthetic transmission lubricant meeting Eaton PS-386 lubricant specification	All	–
Heavy-duty engine oil meeting MIL-L-2104D or Caterpillar TO-4 Specification	Above 10 (–12)	40 or 50
	Below 10 (–12)	30

1. Lubricants listed in order of preference. Do not mix types of oil.

Table 1, Eaton Approved Manual Transmission Lubricants

Lubricant Type ¹	Temperature: °F (°C)	SAE Viscosity
Synthetic transmission lubricant meeting Eaton PS-386 lubricant specification	All	–

1. Do not mix types of oil.

Table 2, Eaton Approved Automated Transmission Lubricants

- Clean the fill plug, then install it in the transmission. Tighten the plug as follows:
 - 25 to 35 lbf·ft (34 to 48 N·m) for Eaton Fuller transmissions with 3/4-inch pipe threads.
 - 60 to 75 lbf·ft (81 to 102 N·m) for Eaton Fuller transmissions with 1-1/4-inch pipe threads.

9.04.02 Allison

Cold Check

**NOTICE:**

Operating a transmission with the fluid level higher or lower than recommended can result in transmission damage. Do not overfill the transmission. Overfilling will force fluid out of the case through the main shaft openings. Fluid overflow may also drain onto the clutch or clutch brake, causing additional problems.

Do not mix types and brands of fluid, because of possible incompatibility. Do not use fluid additives, friction modifiers, extreme-pressure gear fluids, or multiviscosity lubricants.

Clean all dirt away from around the end of the fluid fill tube before removing the dipstick.

**NOTICE:**

Do not allow foreign matter to enter the transmission. Dirt or foreign matter in the hydraulic system may cause undue wear of transmission parts, make valves stick, and clog passages.

It is important to check the fluid level cold to determine if the transmission has a sufficient amount of fluid to be safely operated until a hot check can be performed.

1. Park the vehicle on a level surface, apply the parking brakes, and chock the tires.
2. Run the engine for at least one minute.
3. Shift from DRIVE to NEUTRAL, and then shift to REVERSE to fill the hydraulic system.
4. Shift to NEUTRAL and allow the engine to idle at 500 to 800 rpm.
5. With the engine running at idle, remove the dipstick from the tube and wipe it clean.
6. Insert the dipstick in the tube, then remove the dipstick.
7. Check the fluid level reading and repeat the check procedure to verify the reading.

If the fluid level is within the COLD RUN band, the transmission may be operated until the fluid is hot enough to perform a HOT RUN check.

If the fluid level is not within the COLD RUN band, add or drain fluid as needed to adjust the fluid level to the middle of the COLD RUN band. See Fig. 21, [Dipstick Markings](#). For approved Allison transmission lubricants, see Table 15, [Approved Allison Transmission Lubricants](#).

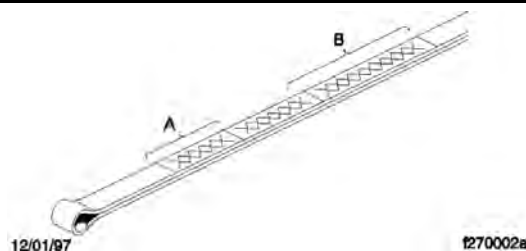

1. Cold Run Band

2. Hot Run Band

Fig 21, Dipstick Markings

Transmission Type	Lubricant Type ¹	Temperature: °F (°C)
All Allison Transmissions	Castrol TranSynd™ (synthetic)	Above -22 (-30)
	Dexron® III	Above -13 (-25)

1. Lubricants are listed in order of preference. Do not mix types of oil.

Table 3, Approved Allison Transmission Lubricants



NOTICE:

Do not fill above the COLD RUN band if the transmission fluid is below normal operating temperature. As fluid temperature increases, so does the fluid level. Filling above the COLD RUN band when the transmission is below normal operating temperature may result in an overfilled transmission, which causes fluid foaming and aeration. Fluid foaming and aeration cause transmission overheating and erratic shifting.

NOTE: Perform a hot check at the first opportunity after the normal operating temperature, 160 to 200°F (71 to 93°C) has been reached.

Hot Check

1. Park the vehicle on a level surface. Apply the parking brakes and chock the rear tires.
2. Shift the transmission to NEUTRAL.
3. Operate the engine at idle (500 to 800 rpm) until normal operating temperature is reached. Check that the sump temperature is 160 to 200°F (71 to 93°C). Check that the converter-out temperature is 180 to 220°F (82 to 104°C).
4. With the engine idling, remove the dipstick from the tube and wipe it clean.
5. Insert the dipstick in the tube, then remove it.
6. Check the fluid level reading and repeat the check procedure to verify the reading. Safe operating level is within the HOT RUN band on the dipstick. The HOT RUN band is between the HOT FULL and HOT ADD marks.

If the fluid level is not within the HOT RUN band, add or drain fluid as needed to bring the fluid level within the HOT RUN band. See Fig. 22, [Dipstick Markings](#). For approved Allison transmission lubricants, see Table 16, [Approved Allison Transmission Lubricants](#).

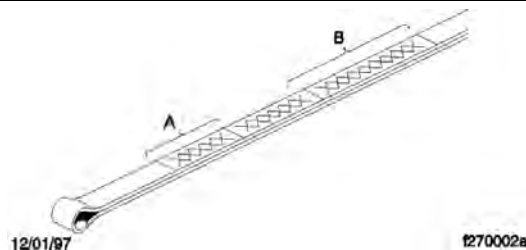

1. Cold Run Band

2. Hot Run Band

Fig 22, Dipstick Markings

Transmission Type	Lubricant Type ¹	Temperature: °F (°C)
All Allison Transmissions	Castrol TranSynd™ (synthetic)	Above -22 (-30)
	Dexron® III	Above -13 (-25)

1. Lubricants are listed in order of preference. Do not mix types of oil.

Table 4, Approved Allison Transmission Lubricants

9.05 Eaton Fuller Transmission Fluid Changing and Magnetic Plug Cleaning

9.05.01 Draining

Eaton Fuller has a complete listing of approved lubricants for its transmissions on its internet website. Refer to the Eaton website for additional information: www.roadranger.com.

IMPORTANT: Manual transmissions filled with approved synthetic lubricants require a lubricant drain and fill, and a magnetic plug cleaning every 500,000 miles (800 000 km), regardless of the service or vocation of the vehicle. Manual transmissions with petroleum-based lubricants require a lubricant drain and fill, and a magnetic plug cleaning at each Maintenance 2 (M2) interval. All transmissions, regardless of lubrication used, also require a check of the transmission breather at each Maintenance 1 (M1) interval.

1. Park the vehicle on a level surface. Apply the parking brakes and chock the rear tires.
2. Drain the fluid while the transmission is warm, as follows.
 - 2.a Clean the area around the drain plug(s). Remove the drain plug(s) from the gear case.
 - 2.b Clean the area around the fill plug or the dipstick tube. Remove the fill plug from the gear case, if applicable.
3. Clean the magnetic plug(s) before installing it. Use a piece of key stock, or any other convenient steel slug, to short the two magnetic poles and divert the magnetic field.
4. Install and tighten the drain plug(s) 50 lbf·ft (68 N·m).

9.05.02 Filling



NOTICE:

Operating a transmission with the fluid level higher or lower than recommended can result in transmission damage. Do not overfill the transmission; overfilling will force fluid out of the case through the main shaft openings. Fluid overflow may also drain onto the clutch or clutch brake, causing additional problems.

IMPORTANT: Do not mix types of fluid, because of possible incompatibility. Do not use multi-viscosity fluids or extreme pressure (EP) gear fluids. Do not use fluid additives or friction modifiers. If switching from a petroleum-based lubricant to a synthetic lubricant, all areas of each affected component must be thoroughly drained. Switching to a synthetic lubricant, when a petroleum-based lubricant has been used for 50,000 miles (80 000 km) or longer may affect transmission performance. Monitor all seal areas for the first 10,000 miles (16 000 km) after changing to a synthetic lubricant from a petroleum-based lubricant.

NOTE: The correct fluid level is established by checking at the fill plug opening (manual and automated).

1. *On manual and automated transmissions*, add fluid until it is level with the lower edge of the fill opening. If the transmission has two fill openings, add fluid to the level of both fill openings. See Table 17, [Eaton Approved Manual Transmission Lubricants](#) for approved transmission lubricants. See Table 18, [Eaton Fuller Transmission Lubricant Capacities](#) for lubricant capacities.
2. Check and adjust the fluid level using the applicable Eaton Transmission fluid level checking procedure.
3. Clean the fill plug (if applicable), then install it in the transmission. Tighten the plug as follows:
 - 25 to 35 lbf·ft (34 to 48 N·m) for Eaton Fuller transmissions with 3/4-inch pipe threads.
 - 60 to 75 lbf·ft (81 to 102 N·m) for Eaton Fuller transmissions with 1-1/4-inch pipe threads.

Lubricant Type ¹	Temperature: °F (°C)	SAE Viscosity
Synthetic transmission lubricant meeting Eaton PS-386 lubricant specification	All	–
Heavy-duty engine oil meeting MIL-L-2104D or Caterpillar TO-4 Specification	Above 10 (–12)	40 or 50

Table 17, Eaton Approved Manual Transmission Lubricants

Lubricant Type ¹	Temperature: °F (°C)	SAE Viscosity
	Below 10 (-12)	30

1. Lubricants listed in order of preference. Do not mix types of oil.

Table 5, Eaton Approved Manual Transmission Lubricants

Transmission Model ¹	Lubricant Capacity: qt (L)
5-Speed	
FS-4205A/B, FS-5205A/B	6.25 (5.9)
FS-6305A/B	9.75 (9.2)
6-Speed	
FS-5406A	9.75 (9.2)
FS-6406A, FSO-6406A	9.75 (9.2)
FO-6406A, FO-8406	10.5 (10.0)
FSO-8406A	9.75 (9.2)
7-Speed	
T-14607A/B	18 (17.5)
TX-14607B	18 (17.5)
9-Speed	
RT-6609A	6 (5.7)
RT-8709B	13.0 (12.3)
RT-8608L	13.5 (12.7)
10-Speed	
FR-9210B	11.75 (11)
FRO-14210C, FRO-15210C	11.75 (11)
RT-8908LL	14 (13.2)
RTO-10910B AS2	13 (12.3)
RTO-11908LL	14 (13.2)
11-Speed	

Table 18, Eaton Fuller Transmission Lubricant Capacities

RTO-11909ALL	14 (13.2)
13-Speed	
RTLO-14913A	14 (13.2)
18-Speed	
RTLO-14918B	14 (13.2)
RTLO-16918B	14 (13.2)

1. For models not listed in this table see the Eaton Fuller website: www.roadranger.com.

Table 6, Eaton Fuller Transmission Lubricant Capacities

9.06 Allison and Eaton Fuller Transmission Breather Checking

Transmission housing breathers (if equipped) must remain clear. A plugged breather could result in pressure build-up, which could cause oil leakage.

If the breather is plugged, clean or replace it. See Fig. 23, [Transmission Breather \(Eaton Fuller shown\)](#). Check more often if the vehicle is operating under very dusty conditions.

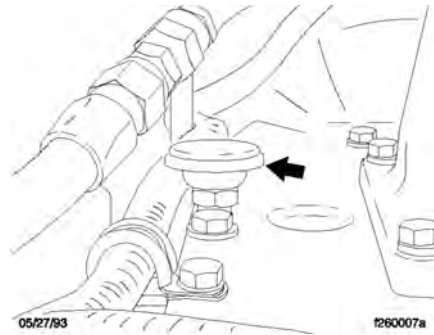

NOTE: Location of the transmission breather will vary depending on transmission model.

Fig 23, Transmission Breather (Eaton Fuller shown)

9.07 Eaton Fuller Transmission Air Filter/Regulator Element Cleaning

NOTE: Eaton Fuller FS/FO and T/TX transmissions do not have an air filter/regulator element that can be serviced.



WARNING:

Exhaust the air supply before servicing the air filter/regulator; otherwise, serious personal injury and component damage could result.

1. Exhaust the air from the air reservoirs.
2. Clean the outside of the air filter/regulator with cleaning solvent, then let it air dry. See Fig. 24, [Eaton Fuller Transmission Air Filter/Regulator Location](#).

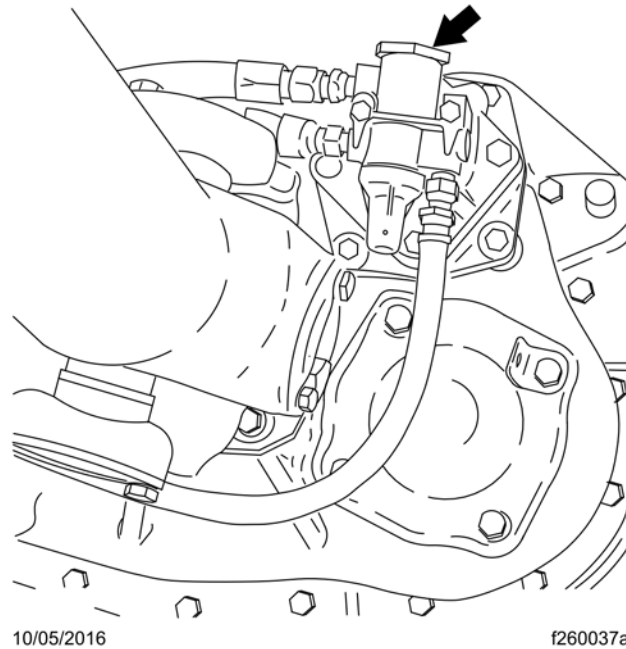
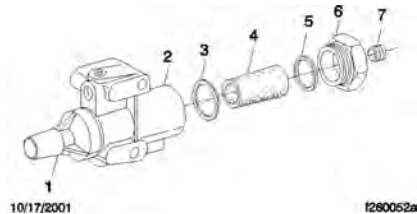

Fig 24, Eaton Fuller Transmission Air Filter/Regulator Location

3. Remove the end cap, large O-ring, and filter element from the filter housing. See Fig. 25, [Eaton Fuller Transmission Air Filter/Regulator Components](#). Remove the small O-ring from the end cap.



- | | |
|--|--|
| <ol style="list-style-type: none"> 1. Air Regulator 2. Housing 3. Large O-Ring 4. Filter Element | <ol style="list-style-type: none"> 5. Small O-Ring 6. End Cap 7. Plug |
|--|--|

Fig 25, Eaton Fuller Transmission Air Filter/Regulator Components

NOTE: Do not remove, disassemble, or adjust the air regulator. If the air regulator is not keeping the air pressure between 57 to 62 psi (396 to 431 kPa), replace the air filter/regulator. It cannot be repaired.

4. Clean the filter element.
 - 4.a Dip the filter element in alcohol or other cleaning solvent. Blow compressed air through the filter element (inside to outside) to loosen surface dirt and to dry the element. The sintered metallic filter element will last the life of the vehicle, provided it is not damaged.
 - 4.b Wipe out the filter housing with a clean, dry, lint-free rag.
5. Clean and inspect the O-rings and the end cap. Replace any parts that are damaged.
6. Install the large O-ring, then the filter element (small end first) into the filter housing.

7. Install the small O-ring in the end cap, then install the end cap on the filter housing. Tighten the end cap until firm.

**NOTICE:**

Repair any air leaks. A leaking air filter or air lines can cause slow or hard shifting of the transmission, and eventual transmission damage.

8. Start the engine, and build pressure in the air system. Check for air leaks at the filter housing and air line connections, and repair any leaks.

9.08 Allison Transmission Fluid and Filter Changing

9.08.01 General information

When draining transmission fluid, check for evidence of dirt or water contamination. A small amount of condensation will appear in the fluid during operation.

Water contamination is normally characterized as a milky discoloration of the transmission fluid. Obvious contamination of the transmission fluid indicates a leak between the water and fluid areas of the transmission cooler. Inspect and pressure-test the cooler to confirm the leak; replace leaking transmission coolers.

9.08.02 MD and HD Series

**NOTICE:**

To prevent dirt from entering the transmission, use only clean containers and fillers for the transmission fluid. Do not use fillers or containers that have been used for water or antifreeze. Dirt, water, or antifreeze could damage the transmission.

1. Park the vehicle on a level surface, shut down the engine, and set the parking brake. Chock the tires.
2. Operate the vehicle until the transmission reaches normal operating temperature: 160 to 200°F (71 to 93°C).
3. Clean the area around the drain plug and the transmission fluid pan. Place a drain pan under the transmission and remove the drain plug. Examine the fluid as it drains. If only the filter is being changed, do not drain the fluid.
4. Remove the 12 mounting bolts (six each) from the two filter covers.

NOTE: A lot of fluid will drain when the filter covers are removed.

5. Remove the filter covers, O-rings, and two square-cut seals from the transmission. See Fig. 26, [Allison MD and HD Series Transmission Filter Locations and Components](#).

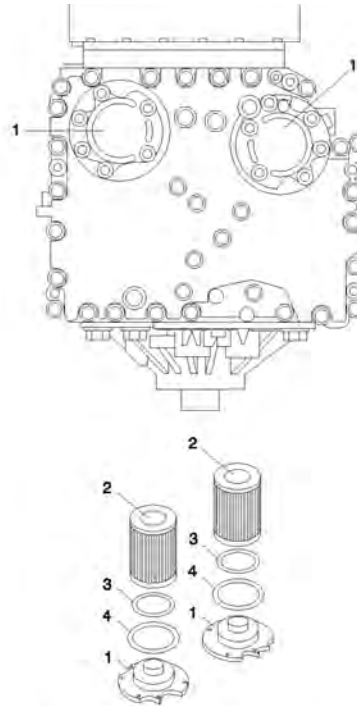

08/25/95

1260317

- 1. Filter Cover
- 2. Filter Element

- 3. Filter Element O-Ring
- 4. Square-Cut Seal

Fig 26, Allison MD and HD Series Transmission Filter Locations and Components

- 6. Remove the filters from the bottom of the control module.
- 7. Lubricate the new O-rings with transmission fluid, and install them on the cover assemblies.
- 8. Install a new square-cut seal on each cover assembly, and install the fluid filter elements on the cover assemblies.
- 9. Install the filter and cover assemblies into the filter compartment.
- 10. Align each cover assembly with the holes in the channel plate sump, and push the cover assemblies in by hand to seat the seals.



NOTICE:

Do not use the bolts to draw the filter covers to the sump. This can damage the covers, seals, or sump.

- 11. Install six bolts in each cover, and torque the bolts 38 to 44 lbf·ft (51 to 61 N·m).
- 12. Install a new drain plug O-ring, and install the drain plug. Tighten the drain plug 18 to 24 lbf·ft (25 to 32 N·m).
- 13. Refill the transmission with fresh Dexron® transmission fluid, shown in Table 19, [Approved Allison Transmission Lubricants](#), and check the fluid level. See Table 20, [Allison Transmission Lubricant Capacities](#) for lubricant capacities.

Transmission Type	Lubricant Type ¹	Temperature: °F (°C)
All Allison Transmissions	Castrol TranSynd™ (synthetic)	Above -22 (-30)
	Dexron® III	Above -13 (-25)

1. Lubricants are listed in order of preference. Do not mix types of oil.

Table 7, Approved Allison Transmission Lubricants

Transmission Series	Transmission Model	Fill Capacity: qt (L) ¹
HD/MD Series	HD4060/4560 (standard sump)	36 (34) ²
	HD4060/4560 (shallow sump)	26 (25) ²
	MD3060/3066/3560 (standard sump)	19 (18)
	MD3060/3066/3560 (shallow sump)	10.5 (10)

1. Quantities listed are approximate. Add the recommended amount of fluid as listed under fill capacity, then perform a "hot check" and add fluid as needed. Do not overfill.

2. Add 3 quarts (3 liters) if equipped with a PTO.

Table 8, Allison Transmission Lubricant Capacities

14. Check and adjust the fluid level using the appropriate Allison Transmission procedure.

10.01 Safety Precautions	76
10.02 Frame Fastener Torque Check	76
10.03 Fifth Wheel Inspecting	77
10.03.01 Fontaine	77
10.03.02 ConMet Simplex®	77
10.03.03 Holland	79
10.04 Fifth Wheel Lubricating	80
10.04.01 Fontaine	80
10.04.02 ConMet Simplex	81
10.04.03 Holland	81
10.05 Trailer Electrical Connector Lubricating	81

10. Frame and Frame Components

10.01 Safety Precautions

Safety Precautions in this section apply to all procedures within this group.

**DANGER:**

When working on the vehicle, shut down the engine or motor, set the parking brake, and chock the tires. Before working under the vehicle, always place jack stands under the frame rails to ensure the vehicle cannot drop. Failure to follow these steps could result in serious personal injury or death.

10.02 Frame Fastener Torque Check

Frame brackets and components secured with Huckbolt® fasteners do not require a torque check, however, they should be inspected for damage. Frame brackets and components secured with conventional bolts and nuts are to be checked at Initial Maintenance (IM). Check the torque of frame fasteners to offset the effects of "bedding in" (or seating). When checking torque, tighten the nut, not the bolt head whenever possible. This will give a true torque reading by eliminating bolt-body friction. When checking the torque of frame fasteners, inspect the frame for cracks and other damage. Set a click-type torque wrench to the maximum torque of the fastener you are checking. Apply pressure until the torque wrench clicks. Do not loosen the bolt to check the torque. See [VIN Information](#) in the *108SD Plus and 114SD Plus Workshop Manual* for torque specifications.

**NOTICE:**

Make sure frame fasteners are properly tightened. Continued vehicle operation with loose fasteners could result in bracket or frame damage.

Check the fasteners at the following locations:

- axle stops
- deck plates
- equalizer brackets
- exhaust brackets
- fifth wheel legs
- fifth wheel mountings
- frame crossmembers and gussets
- front frame brackets
- front suspension spring brackets
- fuel tank brackets
- radius rods
- rear suspension spring brackets
- shock absorbers
- all other suspension fasteners
- all other axle fasteners

- all other frame fasteners

Any component that shows signs of cracking or other damage must be repaired or replaced. Refer to the *108SD Plus and 114SD Plus Workshop Manual* for repair or replacement information.

10.03 Fifth Wheel Inspecting

10.03.01 Fontaine

**WARNING:**

All fifth wheel maintenance, adjustment, and rebuilding must be done only by a qualified mechanic. Improper or incomplete procedures could result in a possible disengagement of the trailer from the tractor, which could result in personal injury or property damage.

Parts are under spring compression. Wear safety goggles while servicing the fifth wheel. Failure to do so can result in personal injury, due to parts ejecting with force.

1. Using a degreaser, clean the fifth wheel and mounting brackets.
2. Inspect for cracks in the fifth wheel assembly, the mounting brackets, and mounting components.
3. Inspect for wear and damage to moving parts.
4. Check for loose nuts and bolts in the fifth wheel and mounting hardware. Tighten nuts and bolts as necessary.
5. Check the wedge adjustment.
 - 5.a Close the fifth wheel on a standard 2-inch (50-mm) kingpin or similar 2-inch (50-mm) diameter shaft so that it locks.
 - 5.b Push on the wedge stop rod with hand pressure. It should move in 1/4 inch (6 mm) and spring back out on release.

If the free travel is not 1/4 inch (6 mm), adjust the distance to 1/4 inch (6 mm) by turning the wedge stop rod, on the right side of the top plate, clockwise to reduce the gap and counter-clockwise to increase it.

10.03.02 ConMet Simplex®

1. Disconnect the tractor from the trailer. For instructions, see [Fifth Wheel Lubrication](#) in the *108SD Plus and 114SD Plus Workshop Manual*.
2. Thoroughly steam-clean the fifth wheel.
3. Check the fifth wheel plate for cracks. Check for sharp edges on top; the chamfer should be 1/8 to 1/4 inch (3 to 6 mm).
4. When the wheel is locked, the safety latch must swing free and fall freely into position. See Fig. 27, [Simplex Series Fifth Wheel](#).

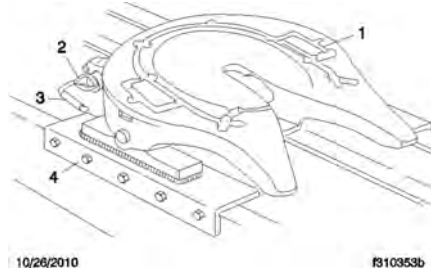

- 1. Lubricant Grooves
- 2. Safety Latch
- 3. Lock Control Handle
- 4. Mount

Fig 27, Simplex Series Fifth Wheel

- 5. The lever bar and operating handle must be in proper alignment. See Fig. 28, [Lever Bar and Operating Handle Alignment](#). Replace any bent or misaligned lever bar or operating rod.

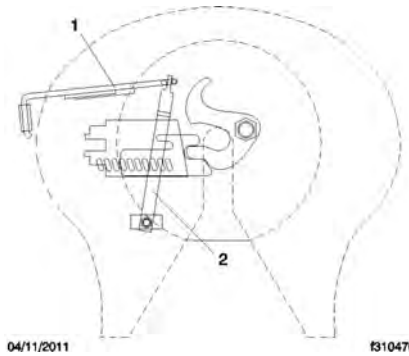

- 1. Operating Handle
- 2. Lever Bar

Fig 28, Lever Bar and Operating Handle Alignment

- 6. Check all clinch pins for cracking or damage. Replace any clinch pin that shows signs of damage.
- 7. Measure the top plate lift. See Fig. 29, [Measuring Fifth Wheel Top Plate Lift](#).

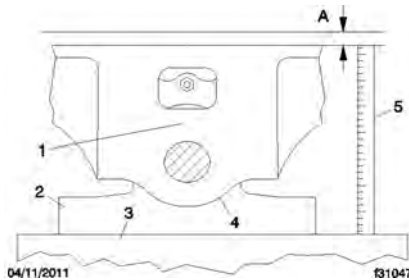

- A. Extended Top Plate Lift Height
- 1. Fifth Wheel Top Plate
- 2. Fifth Wheel Frame Mount
- 3. Frame Rail
- 4. Lifting Point
- 5. Static Top Plate Height

Fig 29, Measuring Fifth Wheel Top Plate Lift

- 7.a Level the fifth wheel plate to a horizontal position.
- 7.b Measure the height from a stationary mounting point, such as the frame rail to the top of the fifth wheel plate.

- 7.c Pry up on the fifth wheel plate below the pin boss, and measure the vertical movement.

NOTE: The bracket connection provides a 9/32-inch (7-mm) vertical clearance to provide cushioning and to avoid downward pin-loading while retaining minimum plate lift.

- 7.d If the plate lift exceeds 5/16 inch (8 mm) as a result of wear or rubber deterioration, install new, standard or oversized bracket-shoe rubber pads; see the *Simplex Fifth Wheel Operating and Maintenance Manual* for replacement instructions.

NOTE: Do not measure plate lift immediately after a trailer has been uncoupled from the fifth wheel. The rubber may have taken a temporary set, which will normally recover after being uncoupled for a short period of time.

8. Check the clearance between the kingpin and the jaw of the fifth wheel. If the clearance is greater than 1/8 inch (3 mm), dial out the slack using the eccentric jaw pin. For detailed instructions, see the *Simplex Fifth Wheel Operating and Maintenance Manual*.
9. Check all mounting bolts for signs of fatigue, and tighten them to the proper torque. For torque specifications, see [VIN Information](#) in the *108SD Plus and 114SD Plus Workshop Manual*. Inspect all angles, plates, and brackets for cracks or other damage.
10. Replace cracked, worn, or damaged parts with new parts. Replace all loose mounting bolts with 5/8–11 SAE grade 8 bolts, grade C locknuts, and hardened washers. *Do not* re-use bolts, nuts, and washers on fifth wheel mountings.
11. After inspecting the fifth wheel, lubricate all moving parts with a chassis or multipurpose grease.

10.03.03 Holland

1. Thoroughly steam clean all fifth wheel components before inspection.
2. Check the fastener torques on the fifth wheel assembly and fifth wheel mounting. Tighten bolts and nuts as needed. Replace missing or damaged bolts. Replace bent, worn, or damaged parts with genuine Holland parts.
3. Using a Holland Kingpin Lock Tester, part number TF-TLN-1000 or TF-TLN-5000, check the operation of the locking mechanism by opening and closing the locks. See Fig. 30, [Holland Fifth Wheel Properly Closed](#).

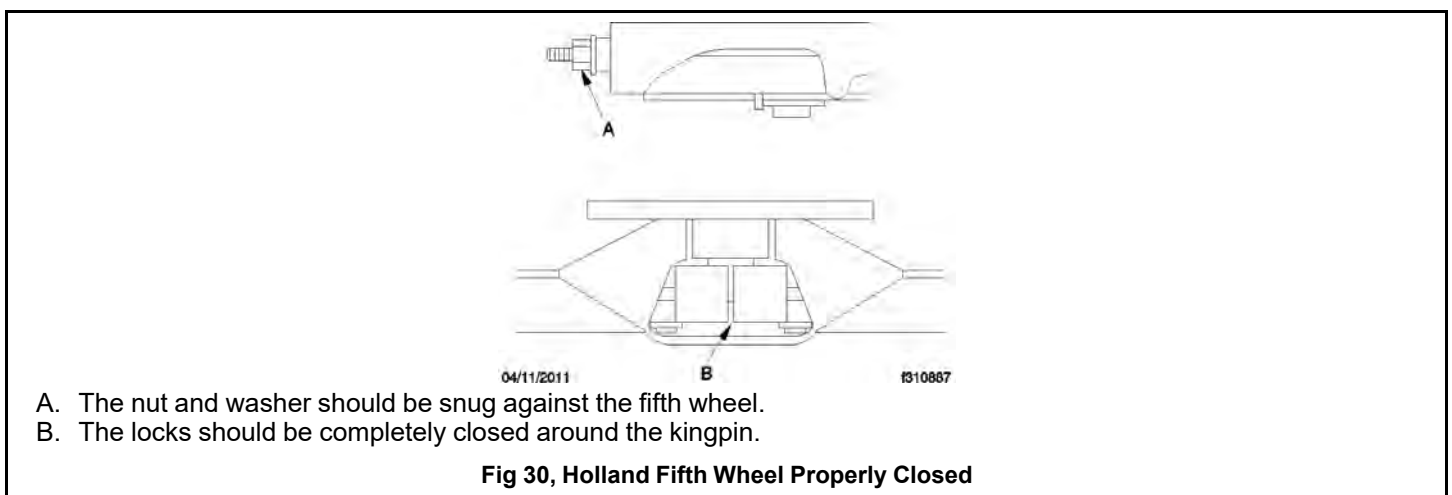

10.04 Fifth Wheel Lubricating

10.04.01 Fontaine

1. Tilt the top plate forward (the front of the fifth wheel is down) and apply grease to each bearing area through the zerk fittings located on each side of the top plate just to the front of the bracket pins. Continue to apply grease until it is coming out of the back of the bearing. It may be necessary to raise the rear of the fifth wheel with a pry bar to open up the pocket slightly and allow the grease to flow through. A substantial amount of grease may be required initially to fill the reservoir.

Tilt the fifth wheel rearward (the rear of the fifth wheel is down) and repeat the greasing procedure. Rock the top plate back and forth several times to spread the grease over the bearing surface.

2. Inspect the trailer kingpin plate and top surface of the fifth wheel to make sure each is properly greased. A liberal coating of grease should be applied to the complete surfaces of both the trailer kingpin plate and the top surface of the fifth wheel.

NOTE: Do not use a lube plate (high density polyethylene) on top of the fifth wheel or on the kingpin instead of grease without prior approval by Fontaine Fifth Wheel. The additional thickness of this material can prevent the proper operation of the fifth wheel and may cause a dangerous condition.

3. Lubricate the fifth wheel prior to opening and closing. Grease the jaw and wedge with a screwdriver and distribute the grease along the full length of the jaw and wedge mating surfaces. See Fig.31, [Fontaine Fifth Wheel](#). Open and close the fifth wheel several times to further distribute the grease.

Lightly oil other moving parts in the fifth wheel.

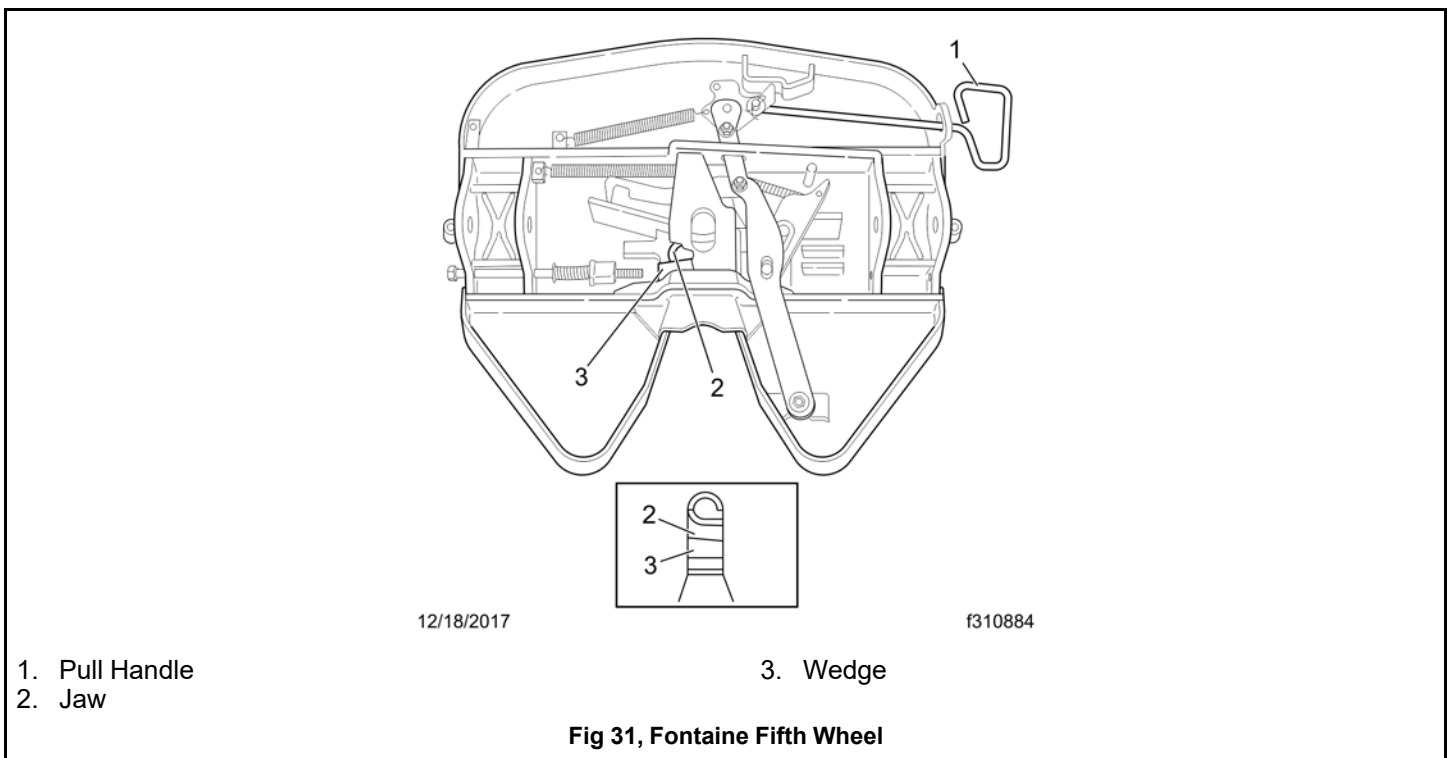

4. Apply grease to the top plate. Spread grease all over the mating surface of the top plate. Be sure the grease pockets built into the top plates are full of grease.

10.04.02 ConMet Simplex

Apply a heavy coat of grease to the top plate, either through the grease fittings located on the underside of the top plate, or by direct application.

Apply grease directly to the lock mechanism.

If lubrication fittings are present, lubricate the interface of the steel bracket shoe and bracket trunnion.

10.04.03 Holland

1. Using a water-resistant lithium-base grease, apply grease to the top plate. Grease the mounting bracket supports through the zerk fittings. See Fig. 32, [Holland Fifth Wheel](#).
2. Using a light oil or diesel oil, lubricate the cam track and pivot. See Fig. 33, [Holland Fifth Wheel Cam Plate](#).

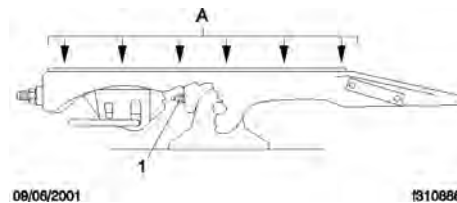

A. Apply grease to the top plate.

1. Zerk Fitting

Fig 32, Holland Fifth Wheel

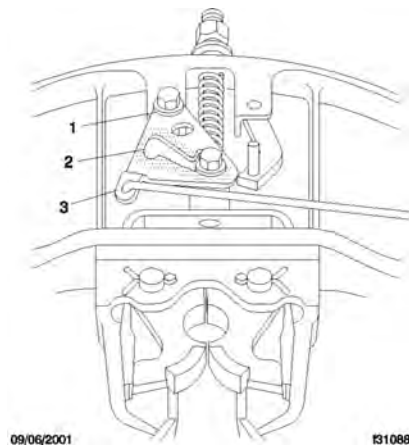

1. Pivot
2. Cam Track

3. Cam Plate

Fig 33, Holland Fifth Wheel Cam Plate

10.05 Trailer Electrical Connector Lubricating

In some cases, failure of trailer cables occurs due to intrusion of chloride-based road deicing chemicals into the trailer connector. Once inside the connector, the chloride-based chemicals corrode the brass terminals and create bridging between positive and ground terminals.

NOTE: The use of soap is not recommended for cleaning the electrical connector, as some soaps may increase the corrosion process.

1. Wash out any existing grease, dirt, and corrosion on the trailer connectors with electrical contact cleaner spray.
2. Grease the trailer connector with a lithium-based dielectric grease.

11.01 Safety Precautions	84
11.02 Suspension Inspecting	84
11.02.01 Inspection of the Freightliner Spring Front and Rear Suspension Spring Assemblies	84
11.02.02 Inspection of the Freightliner Spring Rear Suspension Spring Brackets and Equalizer Brackets (Tandems)	84
11.02.03 Inspection of the Freightliner Spring Tandem Axle Suspension Crossmember and Gussets	84
11.02.04 Freightliner Spring Shock Absorber Check	85
11.02.05 Freightliner 23K, 26K, 30K Spring Single and Tandem Radius Rod Bushing and Spring Check	85
11.02.06 Freightliner Spring Tandem Suspension Equalizer Bushing Check	85
11.02.07 52-Inch Multi-leaf Spring Component Check	86
11.02.08 60-Inch Tapered Leaf Spring Component Check	86
11.02.09 Freightliner AirLiner Component Clearance Check	86
11.02.10 Freightliner AirLiner Component Inspection and Operation Check	87
11.02.11 Freightliner AirLiner Control Rod Check	87
11.02.12 Freightliner TufTrac	87
11.02.13 Hendrickson Suspension Inspection	88
11.02.14 Hendrickson Leaf Spring Assembly Inspection	89
11.02.15 Hendrickson Radius Rod Bushing Check	90
11.02.16 Chalmers Suspension Inspection	90
11.03 Suspension U-Bolt Torque Checking	91
11.04 TufTrac Suspension Gen2 I-Bolt Torque Checking	92

11. Suspension

11.01 Safety Precautions

Safety Precautions in this section apply to all procedures within this group.

**DANGER:**

When working on the vehicle, shut down the engine or motor, set the parking brake, and chock the tires. Before working under the vehicle, always place jack stands under the frame rails to ensure the vehicle cannot drop. Failure to follow these steps could result in serious personal injury or death.

11.02 Suspension Inspecting

11.02.01 Inspection of the Freightliner Spring Front and Rear Suspension Spring Assemblies

Inspect the front and rear suspension spring assemblies for pitted, cracked, broken, or abnormally bent leaves, and extreme rust. If any of these conditions exist, replace the spring assembly. See [General Information, Front Suspension](#) in the *108SD Plus and 114SD Plus Workshop Manual* for instructions.

**WARNING:**

Do not replace individual leaves of a damaged leaf spring assembly; replace the complete spring assembly. Visible damage (cracks or breaks) to one leaf causes hidden damage to other leaves. Replacement of only the visibly damaged part(s) is no assurance that the spring is safe. On front spring assemblies, if cracks or breaks exist in the two top leaves, a loss of vehicle control could occur. Failure to replace a damaged spring assembly could cause an accident resulting in property damage, serious personal injury, or death.

IMPORTANT: On multi-leaf suspensions, closely inspect each component of the leaf spring assemblies, including the brackets, U-bolts, and related parts.

11.02.02 Inspection of the Freightliner Spring Rear Suspension Spring Brackets and Equalizer Brackets (Tandems)

Inspect the forward and rear spring brackets, equalizer brackets (tandems), and the wear pads, for wear, cracks, and other damage. If any of these conditions exist, replace the damaged bracket(s) and wear pad(s). See [General Information, Front Suspension](#) in the *108SD Plus and 114SD Plus Workshop Manual* for instructions.

**WARNING:**

Failure to replace the forward spring brackets, equalizer brackets, or rear spring brackets if they are worn, cracked, or otherwise damaged could result in progressive damage to and eventual breakage of the bracket. This could cause a loss of vehicle control resulting in property damage, serious personal injury or death.

11.02.03 Inspection of the Freightliner Spring Tandem Axle Suspension Crossmember and Gussets

Inspect the tandem-axle frame crossmember and gussets for wear, cracks, and other damage. If any of these conditions exist, replace the damaged parts. See [General Information](#) in the *108SD Plus and 114SD Plus Workshop Manual* for instructions. Check all fasteners for tightness. See [VIN Information](#) in the *108SD Plus and 114SD Plus Workshop Manual* for torque values.

**NOTICE:**

Failure to replace the suspension crossmember or gussets if they are cracked, worn, or otherwise damaged could result in damage to the vehicle chassis.

11.02.04 Freightliner Spring Shock Absorber Check

NOTE: Shock absorbers are optional on spring suspensions.

Make sure that the shock absorber brackets are tight and that the shock absorber is not striking or rubbing on the frame or some other part of the chassis. Check the rubber mounting bushings and replace if worn. Inspect the shock absorber for oil leakage, which is defined as being drips of oil on the sides of the shock absorber.

If the shock absorber is worn or damaged, replace it with a new one.

11.02.05 Freightliner 23K, 26K, 30K Spring Single and Tandem Radius Rod Bushing and Spring Check

1. Without detaching the torque arms, use your hand to attempt to move each of the radius rod ends up, down, in, and out. If there is any movement, replace the torque arm.
2. Inspect the weld seams between the torque arm tube and the shorter bushing tubes. If there are cracks, replace the torque arm. Do not weld the torque arm for any reason.
3. Inspect the spring leaves for cracks, gouges, wear, or abnormal bends.
4. Inspect the rubber bushing ends. See Fig. 34, [Torque Arm Bushings](#). Replace the torque arm for any of the following reasons:
 - There are gaps between the rubber bushing and the pin or the outer steel sleeve.
 - Either bushing end contacts a torque arm pin mounting bolt.
 - There are cracks in the bushing.
 - Part of the rubber bushing extends beyond the outside diameter of the outer bushing sleeve.

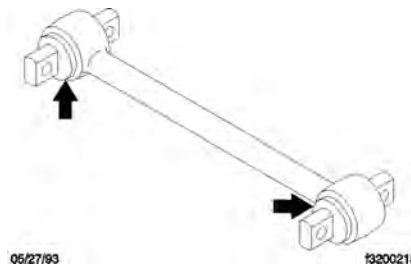
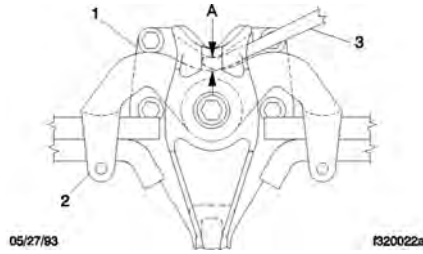

Fig 34, Torque Arm Bushings

11.02.06 Freightliner Spring Tandem Suspension Equalizer Bushing Check

1. Block the frame up enough to take the weight of the chassis off of the springs. Attempt to move the equalizer up and down, by using a pry bar between the top of the equalizer and the top of the equalizer bracket. Apply hand-pressure only. See Fig. 35, [Side View of the Equalizer](#). If movement at the center of the equalizer exceeds 1/8 inch (3 mm), replace the equalizer bushings.



- A. Measure the change in gap at this point.
- | | |
|----------------------|--------------|
| 1. Equalizer Bracket | 2. Equalizer |
| | 3. Pry Bar |

Fig 35, Side View of the Equalizer

- With the vehicle unloaded, attempt to move the equalizer side to side using a pry bar between the equalizer and frame rail. Apply hand-pressure only. See Fig. 36, [Top View of the Equalizer](#). If clearance between the equalizer assembly and any frame component or fastener is less than 1/8 inch (3 mm), replace the equalizer bushings.

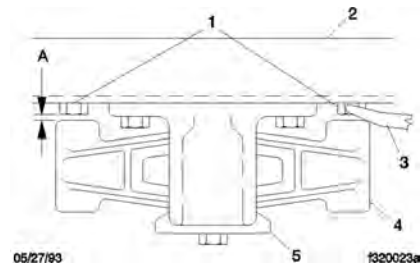

- A. 1/8 inch (3 mm) Clearance
- | | |
|--------------------|----------------------|
| 1. Frame Fasteners | 3. Pry Bar |
| 2. Frame Rail | 4. Equalizer |
| | 5. Equalizer Bracket |

Fig 36, Top View of the Equalizer

11.02.07 52-Inch Multi-leaf Spring Component Check

No lubrication is required on the 52-inch multi-leaf spring rear suspension.

Inspect the stabilizer bar, if present, for irregular bushing wear or cracks in the brackets. Check the rubber helper spring, if present, for cracks.

11.02.08 60-Inch Tapered Leaf Spring Component Check

No lubrication is required on the 60-inch tapered leaf spring rear suspension.

Inspect the rear shackle brackets for bushing wear or cracks.

Inspect the stabilizer bar, if present, for irregular bushing wear or cracks in the brackets. Check the rubber helper spring, if present, for cracks.

11.02.09 Freightliner AirLiner Component Clearance Check

Check that the air line support brackets are positioned so the air lines do not rub against anything. Reposition any configurations that could contact and result in friction and wear. There must be at least 1 inch (25 mm) clearance around the rubber air spring when inflated. If the clearance is less than 1 inch (25 mm), relocate the obstructing parts.

**NOTICE:**

Failure to relocate obstructing parts could result in damage to the air spring.

11.02.10 Freightliner AirLiner Component Inspection and Operation Check

**WARNING:**

Inspect the components and check their operation as described below. Failure to perform these inspections and checks could result in separation of worn suspension components and loss of vehicle control, possibly causing personal injury or death, or property damage.

1. Chock the front tires. Raise the rear of the vehicle so the tires just clear the ground and the suspension is fully extended. Place safety stands under the vehicle frame.
2. Squeeze all air springs to check for complete deflation.
3. Inspect the air spring piston for cracks, chips, and broken areas. Check the air bag for rips, tears, and holes. Verify that the air spring assembly does not leak.
4. Check the axle connection welds (beam seat to equalizing beam) and axle adapter to axle for cracks. If welds are cracked, grind them out and reweld the parts.
5. Move the axle up and down while checking for signs of looseness due to worn parts at the front pivot connections. Replace any worn parts.
6. Inspect the shock absorbers for oil leaks and worn rubber bushings. Replace the shock absorbers and/or rubber bushings if wear or damage is noted.
7. Inspect the stabilizer bar, if so equipped, for irregular bushing wear or cracks in the brackets. The stabilizer bar is optional on 10,000- and 15,000-pound AirLiner suspension systems.
8. Remove the safety stands and lower the rear of the vehicle to the ground. Run the engine until air pressure of at least 100 psi (689 kPa) is maintained throughout the system.
9. Check that all air springs are inflated.

11.02.11 Freightliner AirLiner Control Rod Check

1. Without disconnecting the control rods, use your hand to attempt to move each of the control rod ends up, down, in, and out. If there is any movement, examine the control rods for wear or damage. Replace if necessary.
2. Inspect the rubber bushings for cracks or cuts.
3. Check for any shifting of the barpin.

NOTE: The Freightliner AirLiner Suspension is manufactured at numerous weight ratings up to 46,000 pounds. The control rod on the 46,000-pound-rated suspension is larger, and is fastened differently than on other applications.

4. Check for cracks in the metal components and welds.

11.02.12 Freightliner TufTrac

1. Inspect the suspension spring assemblies for pitted, cracked, broken, or abnormally bent leaves, and extreme rust. If any of these conditions exist, replace the spring assembly.

**WARNING:**

Do not replace individual leaves of a damaged leaf spring assembly; replace the complete spring assembly. Visible damage (cracks or breaks) to one leaf causes hidden damage to other leaves. Replacement of only the visibly damaged part(s) is no assurance that the spring is safe. On front spring assemblies, if cracks or breaks exist in the two top leaves, a loss of vehicle control could occur. Failure to replace a damaged spring assembly could cause an accident resulting in property damage, serious personal injury, or death.

IMPORTANT: On multi-leaf suspensions, closely inspect each component of the leaf spring assemblies, including the brackets, U-bolts, and related parts.

2. Inspect the brackets for cracks in the castings. Inspect the V-rod tower welds for cracking or other signs of damage. Also check for contact between the frame rail and the upper axle clamp brackets. If contact exists, check the V-rod bushing for wear. Check the V-rod fastener torques.
3. Inspect the rubber center bearing and spring tip pads for excessive wear, including de-lamination of the rubber-to-metal shim interface, and distortion and degradation of rubber.
4. Inspect the V-rods and lower control rods for wear and looseness.
 - 4.a Without disconnecting the control rods, use your hand to attempt to move each of the control rod ends up, down, in, and out. If there is any movement, examine the control rods for wear or damage. Replace if necessary.
 - 4.b Inspect the rubber bushings for cracks or cuts.
 - 4.c Check for any shifting of the barpin.
 - 4.d Check for cracks in the metal components and welds.
5. Check all fasteners for looseness.
6. Inspect the shock absorbers for oil leaks and worn rubber bushings. Replace the shock absorbers and/or rubber bushings if wear or damage is noted.

11.02.13 Hendrickson Suspension Inspection

Inspect the suspension assembly for wear, cracks, and damage to its components. Replace the component(s) if any wear, cracks, or damage exists. Check all fasteners for tightness.

Check for distorted or frayed rubber at the beam end bushings. If the bushings are damaged, replace them.

Check that the ends of the equalizer beam are not lower in the beam hanger.

If the equalizer beam ends appear lower, use a jack to raise each beam end, then check for movement of the inner metal of the rubber end bushing. See Fig. 37, [Raising the Beam End](#). Movement cannot be corrected by tightening the fastener, because parts could be damaged. If there is movement, replace the rubber end bushings and all connecting parts.

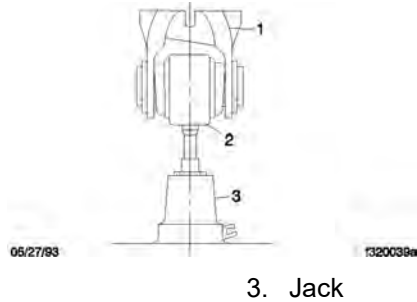

1. Beam Hanger
2. Equalizer Beam

3. Jack

Fig 37, Raising the Beam End

After repairs to the suspension, check the fastener torque after the vehicle has been in service for 2500 miles (4000 km). Tighten the adapter-type beam end connection nut 210 to 240 lbf-ft (285 to 325 N·m). See Fig. 38, [Three-Piece Adapter-Type Beam End Connection](#). Do not overtorque.

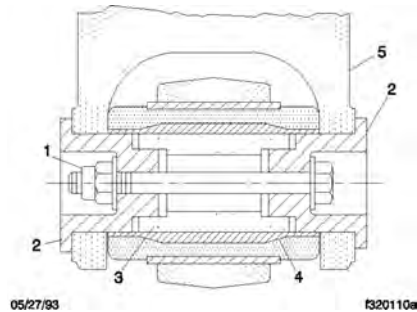

NOTE: Do not use the three-piece adapter without the intermediate tube.

1. Nut
2. Adapter
3. Intermediate Tube

4. Inner Metal of Beam End Bushing
5. Beam Hanger

Fig 38, Three-Piece Adapter-Type Beam End Connection



WARNING:

Insufficient beam end fastener torque could cause the beam to separate from the axle. This will cause loss of vehicle control resulting in property damage, serious personal injury or death.

11.02.14 Hendrickson Leaf Spring Assembly Inspection

1. Inspect the spring hangers for wear of the spring pin holes, cams, and the spring hanger legs. See Fig. 39, [Unloaded RTE Spring Suspension](#).

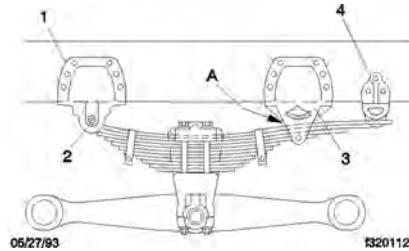

- A. Minimum gap of 3/8 inch (9.5 mm).
1. Forward (no. 1) Spring Hanger
 2. Spring Eye Pin
 3. Rear (no. 2) Spring Hanger
 4. Rear (no. 3) Extension

Fig 39, Unloaded RTE Spring Suspension

2. If equipped with the RTE series, the gap between the rear (no. 2) spring hanger and the top spring leaf should measure at least 3/8 inch (9.5 mm) in an unloaded condition.

If the measurement is less than 3/8 inch (9.5 mm), install new rear (no. 3) extension hangers. Lubricate the bolt threads with SAE 20 oil. Tighten the 1/2–13 locknuts with hardened washers 85 lbf·ft (115 N·m).

3. Inspect the spring leaves for cracks, gouges, wear, or abnormal bends. The main (no. 1) and wrapper spring leaves (no. 2)—the top two spring leaves—may be individually replaced. If equipped with the RTE series suspension, the first, second, and third spring leaves (the top three spring leaves) may be individually replaced. If a spring leaf is damaged below these numbers in a pack, replace the spring assembly. In addition, replace both spring assemblies to ensure even spring deflection.

11.02.15 Hendrickson Radius Rod Bushing Check

1. Without detaching the torque arms, use your hand to attempt to move each of the radius-rod ends up, down, in, and out. If there is any movement, replace the torque arm.
2. Inspect the rubber bushing ends. Replace the torque arm if there are gaps between the rubber bushing and the pin or the outer steel sleeve, if either bushing end contacts a torque arm pin mounting bolt, if there are cracks in the bushing, or if part of the rubber bushing extends beyond the outside diameter of the outer bushing sleeve.

11.02.16 Chalmers Suspension Inspection

Chock the front wheels to prevent the vehicle from moving. Place the transmission in neutral and release the spring or drive-line brakes before inspecting the rear suspension.

Power wash the Chalmers rear suspension or clean it with a hard-bristle brush before performing a visual inspection.

1. Visually inspect the rubber bushings for cracks or other damage.

Try to move the torque rod ends, using your hands only, and check for any free-play. If free-play is felt, replace the torque rod end bushing. Do not use a pry bar to check for free-play. Use of a pry bar may lead to premature bushing replacement.

2. If equipped with optional shock absorbers, check for worn, broken, or damaged shock bushings, heavy corrosion on the shock absorber body, or fluid leaking from the shock absorber. Replace the shock absorbers if any of these conditions are found.
3. Lift the rear of the vehicle and support the frame on jack stands to unload the suspension components. The vehicle is lifted high enough when the beam ends are off of the saddles. All jack stands must be of sufficient strength and rigidity to safely support the vehicle. Do not perform any work on or around a vehicle that is supported solely by a lifting device.

Visually inspect the walking beam for cracks, or other damage. If damage is found, replace the walking beam.

Keep the vehicle supported by the jack stands for the next operation.

- Manipulate the walking beam so that a micrometer, vernier, or dial caliper can be used to determine the wear area thickness on the bottom face. See Fig. 40, [Walking Beam End Wear Thickness](#). Measurements should be taken a minimum of 1/2 inch (13 mm) from the beam flange edges to eliminate any edge wear that may have occurred. Subtract the wear area thickness from the nonwear area to determine the amount of wear.

If the beams show any wear greater than the allowable 0.062-inch (1.5-mm) wear, a Chalmers wear plate must be installed, or the walking beam must be replaced.

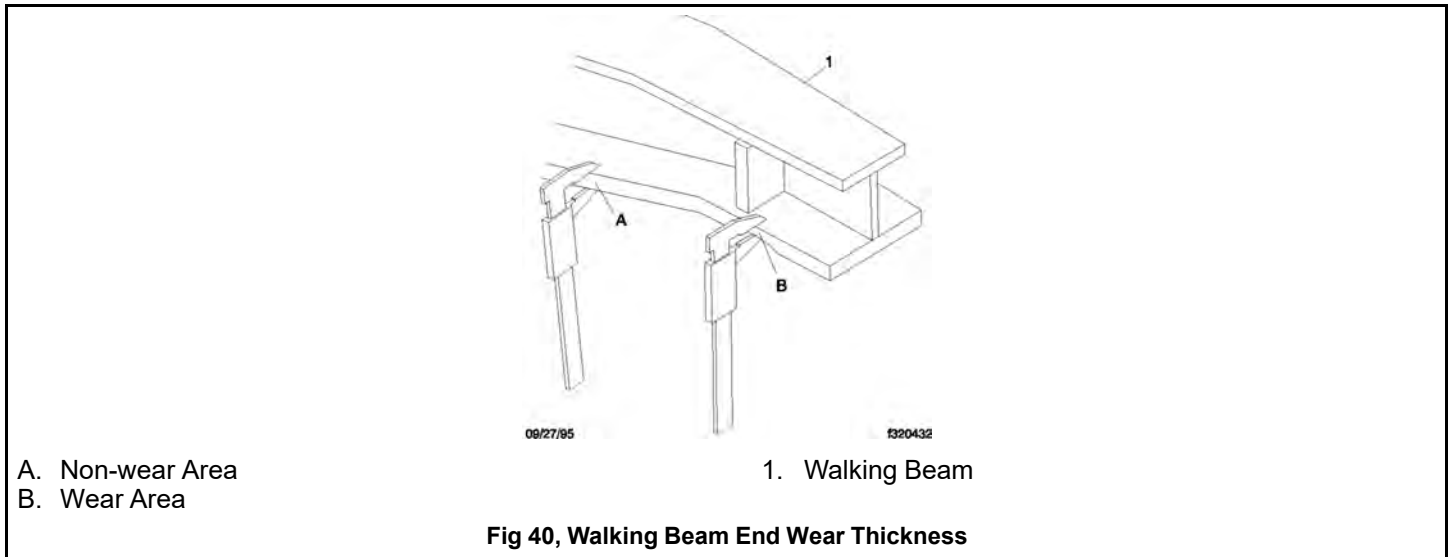

- Rotate the restrictor cans 360 degrees and visually inspect the cans for cracks, severe corrosion, and distortion. If any of these conditions are present or the restrictor can is missing, replace the restrictor can.

**WARNING:**

Replace all cracked or missing restrictor cans. Failure to do so could lead to loss of vehicle control, which could result in property damage, serious personal injury, or death.

- Remove the jack stands, then lower the vehicle. Check that the spring or driveline brake is applied, then remove the wheel chocks.

11.03 Suspension U-Bolt Torque Checking

Check the U-bolt torque of both the front and rear axles where applicable.

**NOTICE:**

Failure to retorque the U-bolt nuts could result in spring breakage and abnormal tire wear.

Check the U-bolt torque of both the front and rear axles and suspension spring packs, where applicable.

1. Park the vehicle on a flat surface and apply the parking brakes. Chock the tires to prevent the vehicle from moving.
2. Check the U-bolt torque in a diagonal pattern. Set a click-type torque wrench to the highest torque value for the fastener being checked. See Table 21, [Spring Assembly U-Bolt High Nut Torque Values](#) for U-bolt torque specifications. Turn the wrench in a clockwise motion (looking up) until the torque wrench clicks.

Size	Torque: lbf-ft (N·m)
5/8–18	Stage 1: Hand-tighten Stage 2: 60 (81) Stage 3: 200 (271) Stage 4: 180 to 230 (245 to 313)
3/4–16	Stage 1: Hand-tighten Stage 2: 60 (81) Stage 3: 200 (271) Stage 4: 270 to 330 (367 to 449)
7/8–14	Stage 1: Hand-tighten Stage 2: 60 (81) Stage 3: 200 (271) Stage 4: 420 to 500 (571 to 680)
1–14	Stage 1: Hand-tighten Stage 2: 60 (81) Stage 3: 200 (271) Stage 4: 520 to 600 (707 to 816)

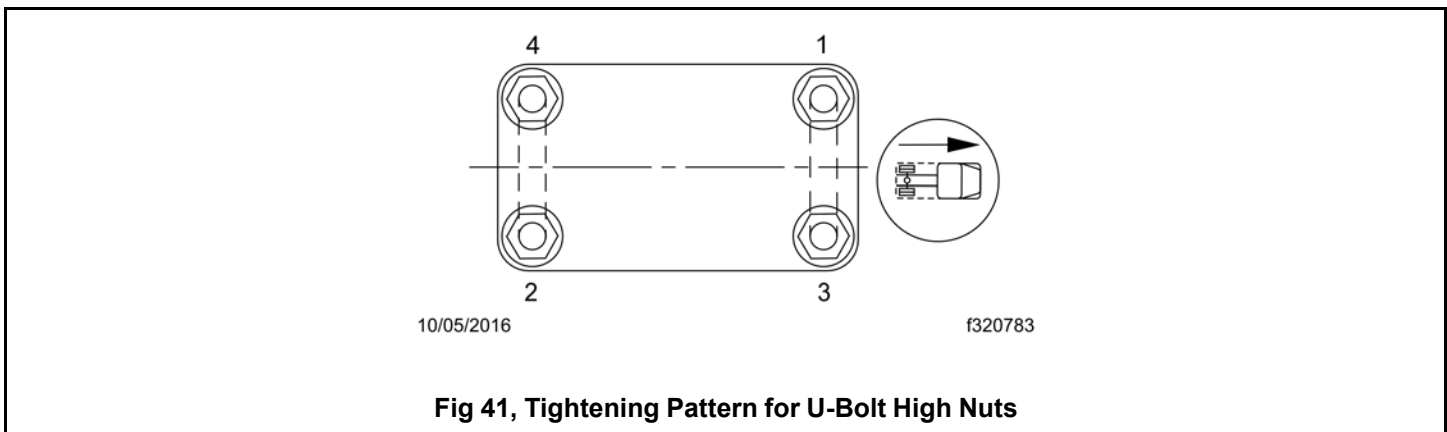

11.04 TufTrac Suspension Gen2 I-Bolt Torque Checking



NOTICE:

Failure to check I-bolt torque values could result in spring breakage and abnormal tire wear.

Check the I-bolt torque of both the front and rear axles, where applicable.

1. Park the vehicle on a level surface, shut down the engine and set the parking brake. Chock the tires.

- Check the I-bolt torque. See Table 22, [Axle Clamp I-Bolt Torque Values](#) for I-bolt torque specifications. Tighten in a diagonal pat-tern as shown in Fig. 42, [Drum Brakes Torque Pattern \(looking up\)](#) and Fig. 43, [Disc Brakes Torque Pattern \(looking up\)](#). Set a click-type torque wrench to the mid-point value for the fastener being checked. Turn the wrench in a clockwise motion (looking up) until the torque wrench clicks, then release pres-sure on the torque wrench, and turn the torque wrench again until it clicks. If the bolt turns on the second application, the bolt is stretching and must be replaced.

Size	Torque: lbf·ft (N·m)
M18–1.5	Stage 1: Hand-tighten Stage 2: 60 (81) Stage 3: 150 (203) Stage 4: 212 to 260 (287 to 352)

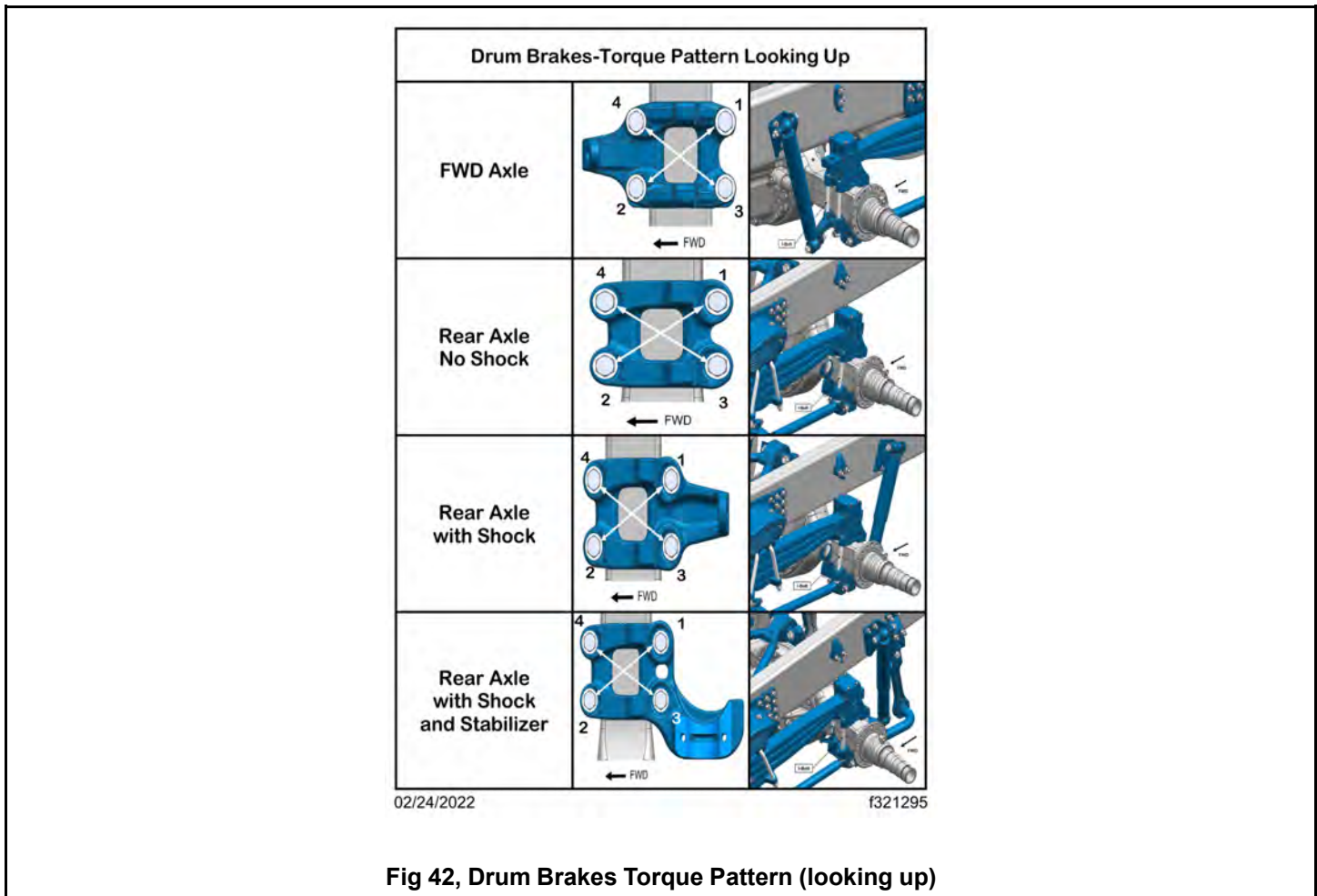

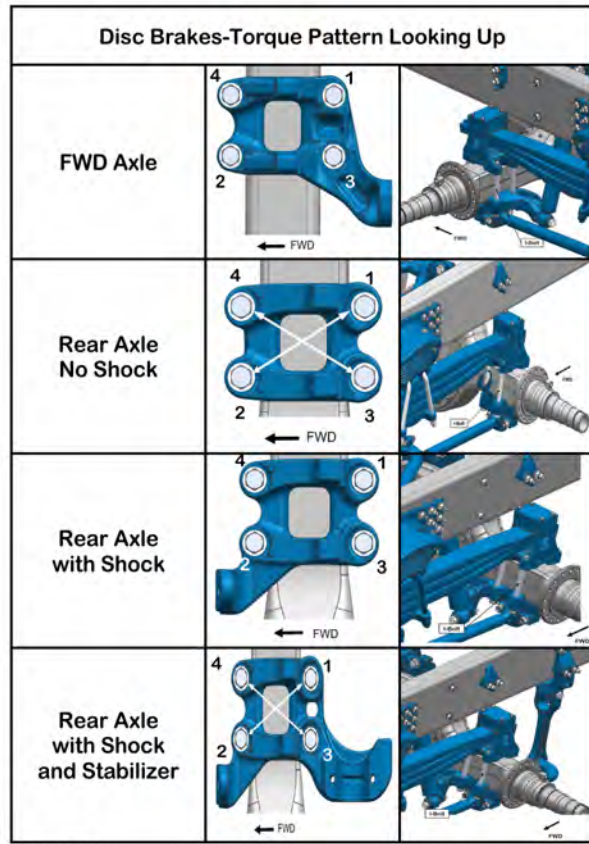

02/24/2022

f321296

Fig 43, Disc Brakes Torque Pattern (looking up)

12.01 Safety Precautions	96
12.02 Kingpin Lubricating	96
12.02.01 Detroit® Axles	96
12.02.02 Sealed and Easy Steer™ Kingpins—Axles With Unitized Wheel Ends	97
12.02.03 Easy Steer™ Kingpins—Axles With Unitized Wheel Ends	98
12.03 Tie Rod End Lubricating	99
12.03.01 Detroit Axles	99
12.03.02 Meritor Axles	99
12.04 Draw Key Nut Torque Checking	100
12.04.01 Axles With Unitized Wheel Ends	100
12.05 Tie Rod End Inspecting	100
12.06 Wheel End Inspection and Maintenance, 6,000-Pound and 8,000-Pound Steer Axles with Oil-Lubricated Hubs	102
12.06.01 General Information	102
12.06.02 Oil Seal Leak Check	103
12.06.03 Hub Cap Leak Inspection	103
12.06.04 Lubricant Inspection	103
12.07 All-Axle Alignment Check	104
12.07.01 Drive Axle Alignment Checking	104
12.07.02 Toe-In Inspection	104
12.08 Steer Axle Hub Cap Vent Plug Inspection	106
12.08.01 General Information	106
12.08.02 Inspection	108

12. Front Axle

12.01 Safety Precautions

Safety Precautions in this section apply to all procedures within this group.



DANGER:

When working on the vehicle, shut down the engine or motor, set the parking brake, and chock the tires. Before working under the vehicle, always place jack stands under the frame rails to ensure the vehicle cannot drop. Failure to follow these steps could result in serious personal injury or death.

12.02 Kingpin Lubricating

12.02.01 Detroit® Axles



NOTICE:

Use regulated pressure when lubricating the knuckle assemblies, otherwise damage could result to the knuckle caps.

1. Park the vehicle on a level surface, shut down the engine, and set the parking brake. Chock the tires. When lubricating upper and lower knuckle assemblies, do not raise the front axle.
2. Wipe the fittings clean.
3. Apply multipurpose chassis grease, NLGI Grade 1 (6% 12-hydroxy lithium stearate grease) or NLGI Grade 2 (8% 12-hydroxy lithium stearate grease), until new grease is seen at the junctions of the axle beam and knuckles. For locations of grease fittings, see Fig.44, [Grease Fittings, Detroit Axles](#); for grease exit points, see Fig. 45, [Kingpin Grease Exit Points, Detroit Axles](#).

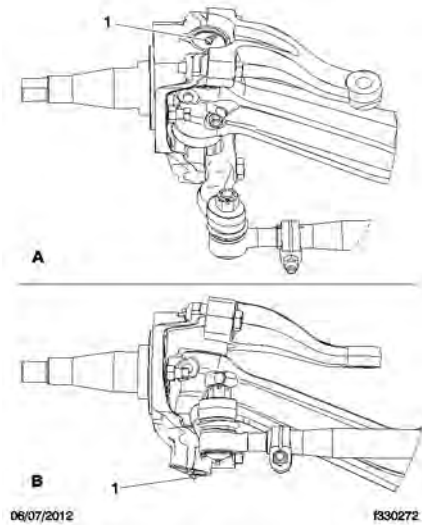

- A. Upper View, LH Side
B. Lower View, LH Side

1. Grease Fitting

Fig 44, Grease Fittings, Detroit Axles

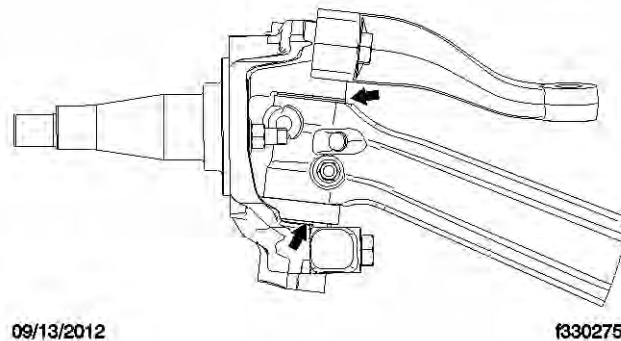

Fig 45, Kingpin Grease Exit Points, Detroit Axles

12.02.02 Sealed and Easy Steer™ Kingpins—Axles With Unitized Wheel Ends

NOTE: This procedure applies to 921, 931, 932, 933, 934, 941, 942, 943, 951, 961, 963, 966, 967, 971, and 975 Series Easy Steer sealed front axles. Refer to the identification tag on the front of the axle beam.

On sealed and Easy Steer Plus™ front axles, the grease fittings are on the top and bottom kingpin caps of the knuckle.

1. Shut off the engine, apply the brakes, and chock the rear tires.
2. Make sure the tires touch the ground. **Do not** raise the vehicle.
3. Clean off all grease fittings prior to lubrication.

IMPORTANT: Meritor recognizes that industry trends are moving toward increased selection and usage of synthetic grease in vehicle maintenance. However, some seals are known to expand when in contact with synthetic grease. Consult your local Meritor representative for synthetic grease application references **before** using any synthetic grease when performing axle service and maintenance.

- Using a multipurpose grease, NLGI grade 1 or 2, lubricate the kingpins through the grease fittings on the top and bottom of the knuckle. See Fig. 46, [Sealed, Easy Steer Kingpin Lubrication](#).

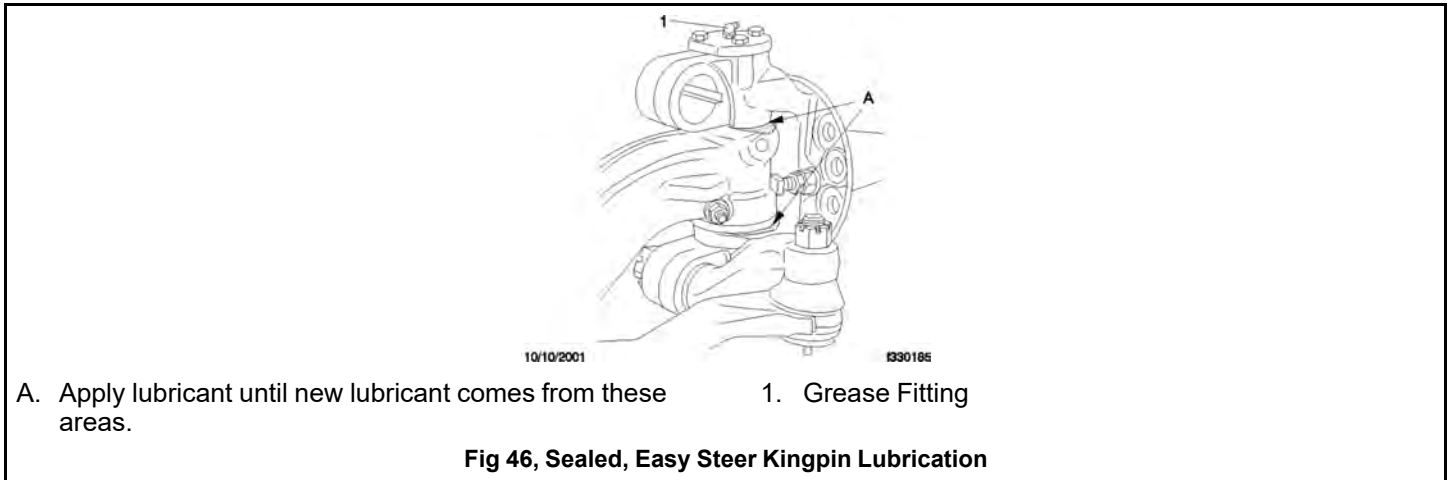

- Apply lubricant until new lubricant comes from the thrust bearing seal and the upper shim pack.
- Remove the chocks from the tires.

12.02.03 Easy Steer™ Kingpins—Axles With Unitized Wheel Ends

NOTE: This procedure applies to Easy Steer Plus™ MFS 10-2015-N and MFS 12-2015-N sealed front axles. Refer to the identification tag on the front of the axle beam.

On Easy Steer Plus front axles, the grease fittings are on the top and bottom kingpin caps of the knuckle.

- Shut off the engine, apply the brakes, and chock the rear tires.
- Make sure the tires touch the ground. **Do not** raise the vehicle.
- Clean off all grease fittings prior to lubrication.

IMPORTANT: Meritor recognizes that industry trends are moving toward increased selection and usage of synthetic grease in vehicle maintenance. However, some seals are known to expand when in contact with synthetic grease. Consult your local Meritor representative for synthetic grease application references **before** using any synthetic grease when performing axle service and maintenance.

- Using a multipurpose grease, NLGI grade 1 or 2, lubricate the kingpins through the grease fittings on the top and bottom of the knuckle. See Fig. 47, [Sealed, Easy Steer Plus Kingpin Lubrication](#).

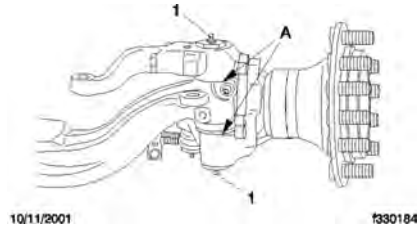

- A. Apply lubricant until new lubricant comes from these areas.
1. Grease Fitting

Fig 47, Sealed, Easy Steer Plus Kingpin Lubrication

5. Force lubricant into the upper and lower kingpin grease fitting caps until new lubricant flows from between the upper axle beam end and the knuckle, and between the lower axle beam end and the knuckle. See Fig. 47, [Sealed, Easy Steer Plus Kingpin Lubrication](#).
6. Remove the chocks from the tires.

12.03 Tie Rod End Lubricating

12.03.01 Detroit Axles

For any Detroit axle that requires lubrication of the tie-rod ends, wipe the grease fittings clean, then pump multipurpose chassis grease, NLGI Grade 1 (6% 12-hydroxy lithium stearate grease) or NLGI Grade 2 (8% 12-hydroxy lithium stearate grease), into the tie-rod ends until all used grease is forced out and fresh grease is seen at the ball stud neck. See Fig. 48, [Grease Fitting and Boot, Detroit Axle](#).

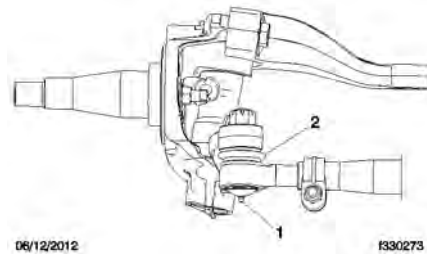

NOTE: No grease should emit from the tie-rod boot. If grease emits from the tie-rod boot, the boot is damaged.

1. Grease Fitting
2. Boot

Fig 48, Grease Fitting and Boot, Detroit Axle

12.03.02 Meritor Axles

This procedure applies to all tie rod ends on Meritor nondrive steering axles.

1. Park the vehicle with the wheels in the straight-ahead position. Turn off the engine, apply the brakes, and chock the rear tires.
2. Wipe clean the zerk fitting and the seal or boot.

NOTE: Synthetic lubricants are not approved for tie rod end lubrication.

- Using a grease gun, apply a multipurpose grease, NLGI grade 1 or 2, to the zerk fitting until all the old grease is purged from the boot. Discolored old grease should come out of the purge holes near the boot crimp or bellows area. Apply grease until all the old grease is purged from the boot.

NOTE: If using an air pressure grease gun, do not exceed 150 psi (1035 kPa).

- If the tie rod end is designed for lube service and it does not accept grease, perform the following substeps.
 - Remove the zerk fitting.
 - Inspect the threaded zerk fitting hole in the tie rod end, and remove any obstructions.
 - Install a new zerk fitting.
 - Apply lubrication to the new zerk fitting.
- Remove the chocks from the tires.

12.04 Draw Key Nut Torque Checking

12.04.01 Axles With Unitized Wheel Ends

Check the torque of the nut that holds the draw key on the side of the knuckle. The torque should be 30 to 45 lbf-ft (41 to 61 N·m). See Fig. 49, [Draw Key Nut](#).

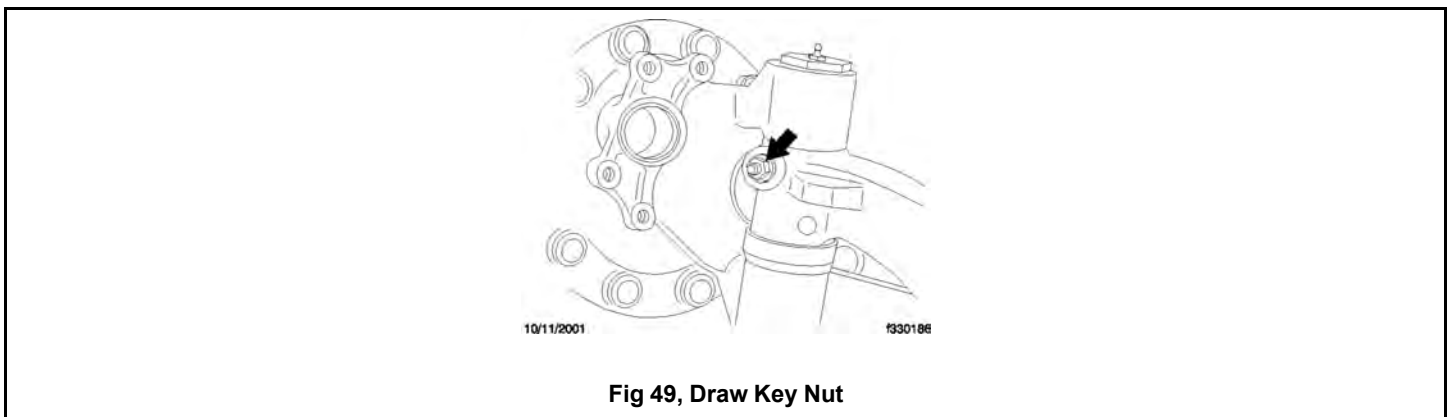

Fig 49, Draw Key Nut

12.05 Tie Rod End Inspecting

IMPORTANT: If the tie rod end boot is torn or missing, replace the entire tie rod end. Do not replace the boot only.

- Shut off the engine, apply the brakes, and chock the rear tires.
- Raise the front of the chassis and support on jack stands.
- Inspect all steering linkage for cracks, dents or bends. Also make sure that the cross steering tube clamp bolts, steering lever and cross steering lever bolts are tightened to specification. Service or replace as necessary.
- Check the tie rod boot for cracks, tears, or other damage. If the tie rod boot is damaged, replace the entire tie rod end.

**WARNING:**

A cotter pin must be installed through the threaded end of the ball socket stud and the nut must be tightened to proper specification. A missing cotter pin can allow the ball socket stud and nut to loosen and possibly result in a total loss of steering control.

5. Check that the tie rod end nut is installed and secured with a cotter pin.
6. If a cotter pin is missing, check the tie rod end nut to make sure it is tightened to specification. Always tighten the nut to the specified torque. If the nut does not align with the cotter pin hole, continue tightening until the cotter pin can be inserted through both the nut and the end of the tie rod end stud. Do not loosen the nut in order to install the cotter pin.
7. Inspect the tie rod end to ensure that the socket is threaded correctly into the cross steering tube and that threaded engagement is deeper than the slot in the tube. Threads of the ball socket must be visible for the entire length of the cross steering tube slot. The threaded portion of the tie-rod end assembly must be inserted all the way into the cross-tube split for adequate clamping. See Fig. 50, [Tie-Rod End Adjustment](#). Replace the components if this cannot be done. For instructions, see [General Information, Front Axle Alignment](#) in the *108SD Plus and 114SD Plus Workshop Manual*.

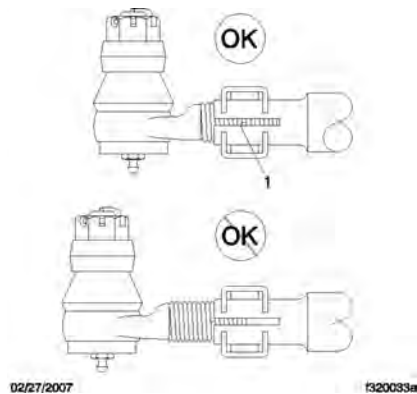

NOTE: Shown without pinch bolt to provide clarity.

1. Cross-Tube Split

Fig 50, Tie-Rod End Adjustment

8. Rotate steering wheel with Engine off. Check for any movement
9. Grasp by hand (or use a pipe wrench with jaw protectors to avoid gouging the cross tube) and slightly rotate the cross tube toward the front of the vehicle and then slightly toward the rear. Then center the cross tube between the stop positions. If the cross tube does not rotate in either direction, replace both tie rod ends.
10. Position yourself directly below the ball stud socket. Using both hands, grab the end as close to the socket as possible, no more than 6 inches (15.2 cm) from the end. Firmly apply about 100 pounds of hand pressure in an up and down motion several times. When moving the assembly, check for any movement at both tie rod ends. See Fig. 51, [Checking the Movement of the Tie Rod End](#).

If any movement is detected at one tie rod end, replace **both** tie rod ends. Always replace tie rod ends in pairs, even if only one tie rod end is damaged.

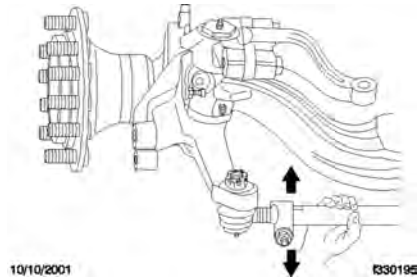

Fig 51, Checking the Movement of the Tie Rod End



CAUTION:

Do not attempt to straighten a bent cross tube. Doing so could result in damage to the axle. Be sure to replace the cross tube with an original equipment cross tube with the same length, diameter, and thread size as the existing cross tube.

11. Check the cross tube for cracks or other damage. If the cross tube is bent or damaged, replace the cross tube.
12. Check the clamps for damage. If a clamp is damaged, replace the clamp. Replace the entire cross tube assembly if either clamp is welded to the cross tube.
13. Check for proper installation of the tie rod end clamp to the cross tube. Make sure that the tie rod ends are threaded in the cross tube past the clamps and the slots at the cross tube ends.
14. Check the zerk fittings for damage. If a zerk fitting is damaged, replace it.
Some tie rod ends have no zerk fittings because they are not greaseable. Do not install a zerk fitting on a non-greaseable tie rod end.
15. Check that the cotter pin is in place. If it is not, tighten the tie rod end nut to one of the following specs depending on the size of the stud.
 - 7/8–14, 160 to 300 lbf·ft (217 to 406 N·m)
 - 1–14, 250 to 450 lbf·ft (339 to 610 N·m)
 - 1-1/8–12, 350 to 650 lbf·ft (475 to 881 N·m)
 - 1-1/4–12, 500 to 675 lbf·ft (678 to 915 N·m)
16. Check the steering arm bolts for a minimum torque of 300 lbf·ft (406 N·m). If the steering arm bolt torque has fallen below this specification, remove the bolt, clean all the threads, and apply new Loctite® 680. Tighten the bolt 300 to 450 lbf·ft (406 to 610 N·m).
17. Remove the chocks from the tires.

12.06 Wheel End Inspection and Maintenance, 6,000-Pound and 8,000-Pound Steer Axles with Oil-Lubricated Hubs

12.06.01 General Information

Periodic inspection and maintenance of wheel ends on 6,000-pound and 8,000-pound steer axles is essential to sound wheel bearing performance. Check for leaks at the oil seal and hub, and inspect the lubricant per the maintenance intervals provided in [2.01 Determining Scheduled Maintenance Intervals](#) in this manual.

12.06.02 Oil Seal Leak Check

Check for evidence of oil leakage at the oil seal. If a leak is found, replace the seal. See [General Information, Front Axle Alignment](#) in the *108SD Plus and 114SD Plus Workshop Manual* for instructions.

12.06.03 Hub Cap Leak Inspection

Check for evidence of oil leakage between the hub cap, gasket and hub surface. If leakage is evident, replace the gasket with a new one. See [General Information, Hub Assembly, Front Axle Wheel Hubs, Brake Drums, and Wheel Bearings](#) in the *108SD Plus and 114SD Plus Workshop Manual* for instructions.

Check for a missing hub cap fill plug or vent plug. See Fig. 52, [Stemco Hub Cap](#). Replace any missing parts. If a vent plug is missing, the oil quality is compromised and must be replaced. See [General Information, Front Axle Alignment](#) in the *108SD Plus and 114SD Plus Workshop Manual* for instructions.

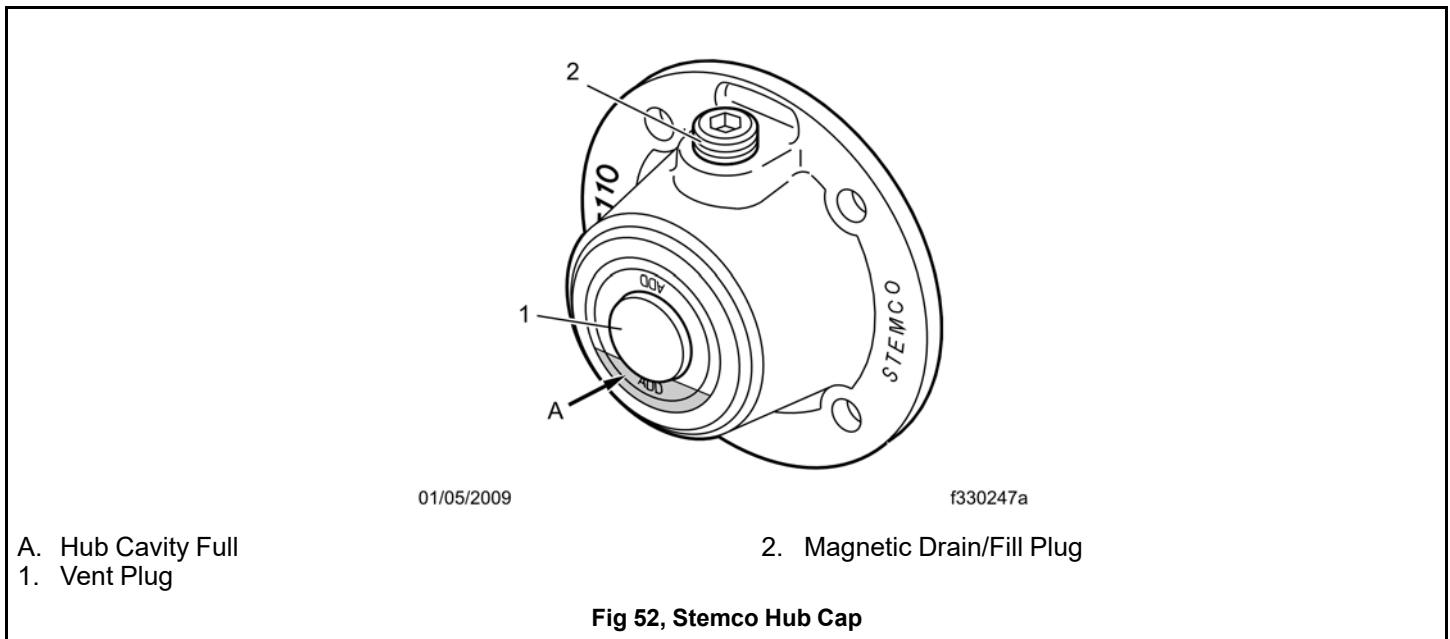

12.06.04 Lubricant Inspection

Rotate the hub so that the fill plug is down, and drain a small sample of hub oil into a plastic container that is free of debris, especially any metallic particles. Then use a magnet to probe the sample. Note whether there is substantial metallic debris present, and compare the oil color to new approved oil. Acceptable oil will have a color similar to new oil and have no water or metal contaminants.

If the oil is not acceptable, inspect the bearings for damage. Replace the bearings as needed, and install the hub per the [General Information, Front Axle Alignment](#) topic in the *108SD Plus and 114SD Plus Workshop Manual*.

If the oil is acceptable, check the oil level. If it is not full (see Fig. 53, [Stemco Hub Cap](#)), fill it to the bottom of the vent plug hole with approved lubricant (see Table 23, [Lubricant Specifications, Over-the-Road Service Applications](#)).

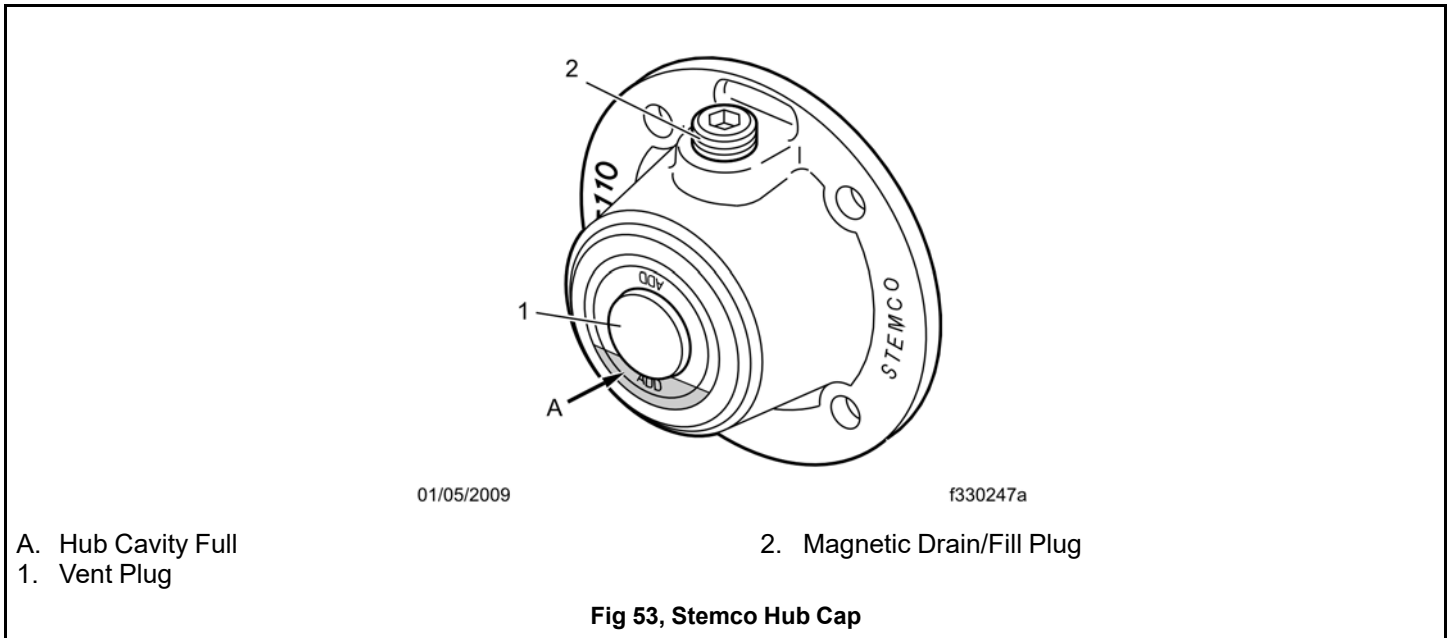

Lubricant Type	Lubricant SAE Viscosity Grade
Synthetic Drive Axle Lubricants or Equivalent with SAE Specification J2360 or Military Specification MIL-L-2105E	75W-90

Table 9, Lubricant Specifications, Over-the-Road Service Applications

12.07 All-Axle Alignment Check

12.07.01 Drive Axle Alignment Checking

Check the axle alignment, parallelism, and thrust angle measurements for the rear drive axles. Use the applicable procedure and specifications in [General Information](#), [Rear Axle Alignment](#) in the *108SD Plus and 114SD Plus Workshop Manual*.

12.07.02 Toe-In Inspection

For vehicle alignment to be accurate, the shop floor must be level in every direction. The turn plates for the front wheels must rotate freely without friction, and the alignment equipment must be calibrated every three months by a qualified technician from the equipment manufacturer. Freightliner dealers must have proof of this calibration history.

1. Apply the parking brakes and chock the rear tires.
2. Raise the front of the vehicle until the tires clear the ground. Place safety stands under the axle.
3. Using spray paint or a piece of chalk, mark the entire center rib of each front tire.
4. Place a scribe or pointed instrument against the marked center rib of each tire, and turn the tires. The scribe must be held firmly in place so that a single straight line is scribed all the way around each front tire.
5. Place a turn-plate or turntable under both front tires. Remove the safety stands and lower the vehicle. Remove the lock-pins from the gauges; make sure the tires are exactly straight ahead.

NOTE: If turn-plates or turntables are not available, lower the vehicle. Remove the chocks from the rear tires and release the parking brakes. Move the vehicle backward, then forward about six feet (two meters).

6. Place a trammel bar at the rear of the front tires; locate the trammel pointers at spindle height, and adjust the pointers to line up with the scribe lines on the center ribs of the front tires. See Fig. 54, [Wheel Toe-In \(overhead view\)](#). Lock in place. Check that the scale is set on zero.

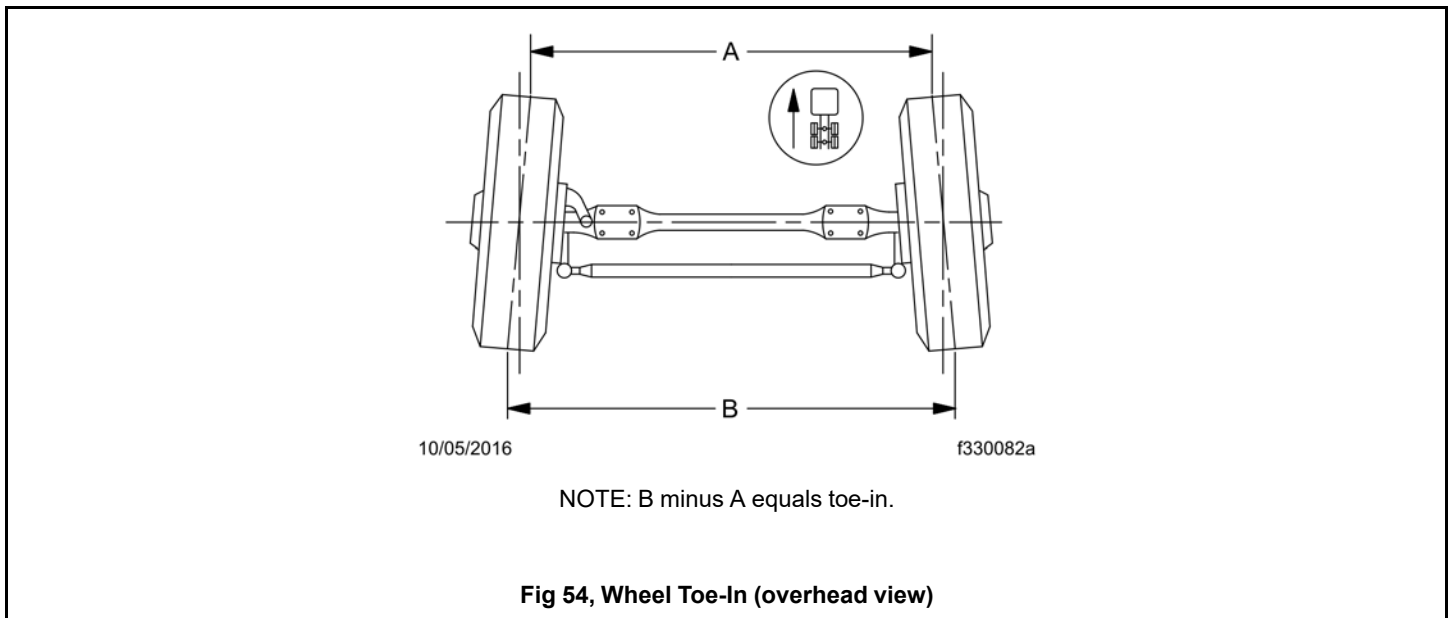

7. Place the trammel bar at the front of the tires (see Fig. 55, [Trammel Bar Positioning](#)) and adjust the scale end so that the pointers line up with the scribe lines. See Fig. 56, [Setting Trammel Bar Pointers](#).

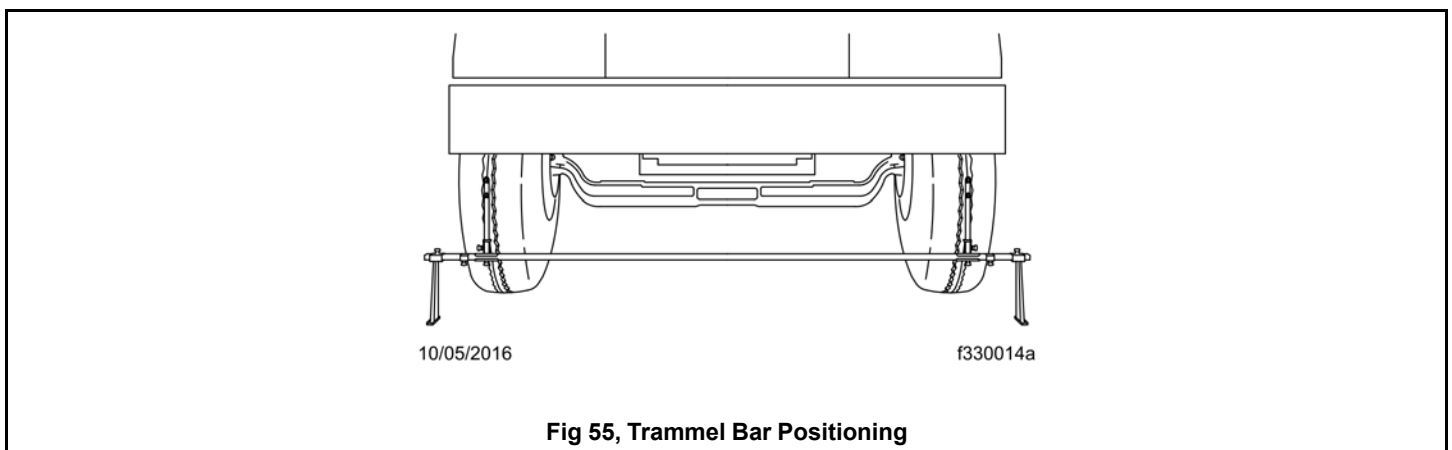

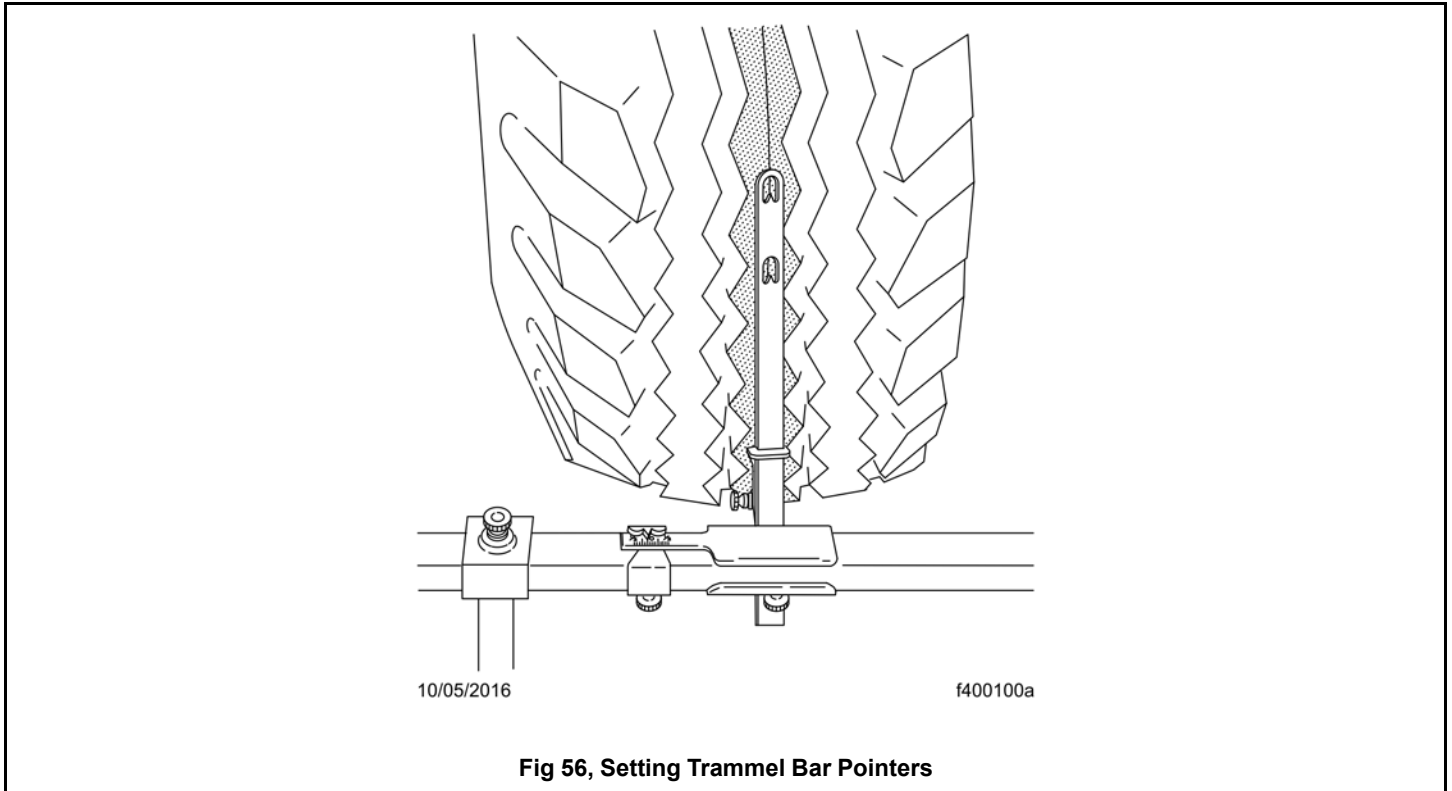

8. Read the toe-in from the scale, and compare it to the toe-in specification in [General Information, Front Axle Alignment](#) in the *108SD Plus and 114SD Plus Workshop Manual*. If corrections are needed, refer to [General Information, Front Axle Alignment](#) in the *108SD Plus and 114SD Plus Workshop Manual* for instructions on adjusting the toe-in.

12.08 Steer Axle Hub Cap Vent Plug Inspection

12.08.01 General Information

As a function of their design, hubcap vent plugs will on occasion exhibit signs of hub oil on their exterior surface. Depending on environmental conditions and/or age of the plug, the amount of oil present can vary. This is a normal result of the venting process due to pressure increase within the hub cavity. For an example of normal vent plug appearance, see Fig. 57, [Normal Oil Venting](#).



09/01/2016

f330298

Fig 57, Normal Oil Venting

A vent plug can wear or be damaged and cause excessive leakage, or allow water to enter the hub and contaminate the oil. For examples of a leaking vent plug, see Fig. 58, [Excessive Leakage](#) and see Fig. 59, [Water in Oil](#). Evidence of a leaking vent plug may appear as;

- Oil splatter around the wheel
- Goopy/gummy oil around the vent plug purge point
- Hub/plug area is dirty, and water contaminated oil in the hub.
- Hub/plug area is clean, but there is water contaminated oil in the hub. (pressure washing is the most likely cause)



09/01/2016

f330299

Fig 58, Excessive Leakage

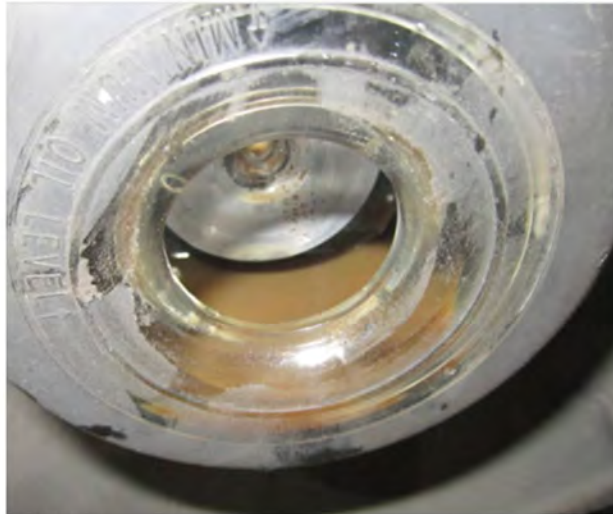

09/01/2016

f330300

Fig 59, Water in Oil

12.08.02 Inspection

**NOTICE:**

Only remove vent plugs by hand. They can be damaged if a tool is used. Wipe the hub/plug area clean before checking the oil. Do not use a pressure washer to clean the hub/plug area. The plug has a vent and this can contaminate the oil with water.

1. Park the vehicle on a level surface, shut down the engine and set the parking brakes. Chock the tires.
2. Inspect the axle hub cap and vent plug for evidence of excessive leakage.
3. Wipe the hub cap and vent plug clean with a rag.
4. Remove the vent plug and check the oil for evidence of water contamination.

If there is evidence of water contaminated oil in the hub, disassemble the effected axle end, clean, inspect, and reassemble the axle end. For instructions, refer to [General Information, Front Axle Alignment](#) in the *108SD Plus and 114SD Plus Workshop Manual*.

If there is evidence of excessive leakage, remove the damaged part and replace it with a new part.

5. Check the oil level in the hub, and fill the hub with new approved oil as needed.

13.01 Safety Precautions	110
13.02 Axle Lubricant Level Checking.....	110
13.02.01 Detroit®	110
13.02.02 Meritor	112
13.03 Axle Breather Checking	115
13.04 Axle Lubricant Changing and Magnetic Plug Cleaning.....	115
13.04.01 General Information	115
13.04.02 Detroit®	116
13.04.03 Meritor	118

13. Rear Axle

13.01 Safety Precautions

Safety Precautions in this section apply to all procedures within this group.

**DANGER:**

When working on the vehicle, shut down the engine or motor, set the parking brake, and chock the tires. Before working under the vehicle, always place jack stands under the frame rails to ensure the vehicle cannot drop. Failure to follow these steps could result in serious personal injury or death.

13.02 Axle Lubricant Level Checking

13.02.01 Detroit®

1. Park the vehicle on a level surface, shut down the engine, and set the parking brake. Chock the tires.
2. If the vehicle has just been driven, allow a few minutes for the lubricant to settle.

IMPORTANT: On Detroit axles, the oil change interval for long haul vehicles can be extended to 500,000 miles (800 000 km) for axles with weight ratings of 34,000 to 40,000 lb (15 000 to 18 000 kg) using synthetic lubricant if a lubricant analysis shows adequate quality. Oil must be changed at least every four years, and more often if the axle is exposed to high temperatures and steep grades.

3. Clean the fill plug and the area surrounding the fill plug on the side of the axle carrier. Remove the plug. Check lubricant level when the axle is cold, or near room temperature.

NOTE: Some Detroit axles have a small tapped and plugged hole near and below the housing oil fill hole. This smaller hole is for a lubricant temperature indicator only, and should not be used as a fill or level hole.

4. Check that the lubricant is level with the bottom of the fill hole. See Fig. 60, [Axle Lubricant Level Inspection](#). If low, check for oil leaks, and correct as needed. Add oil to the level of the fill plug, using the lubricant recommended in Table 24, [Detroit Drive Axle Lubricants](#). See Table 25, [Detroit Rear Axle Lubricant Capacity \(Hubs Full\)](#) for lubricant capacities.

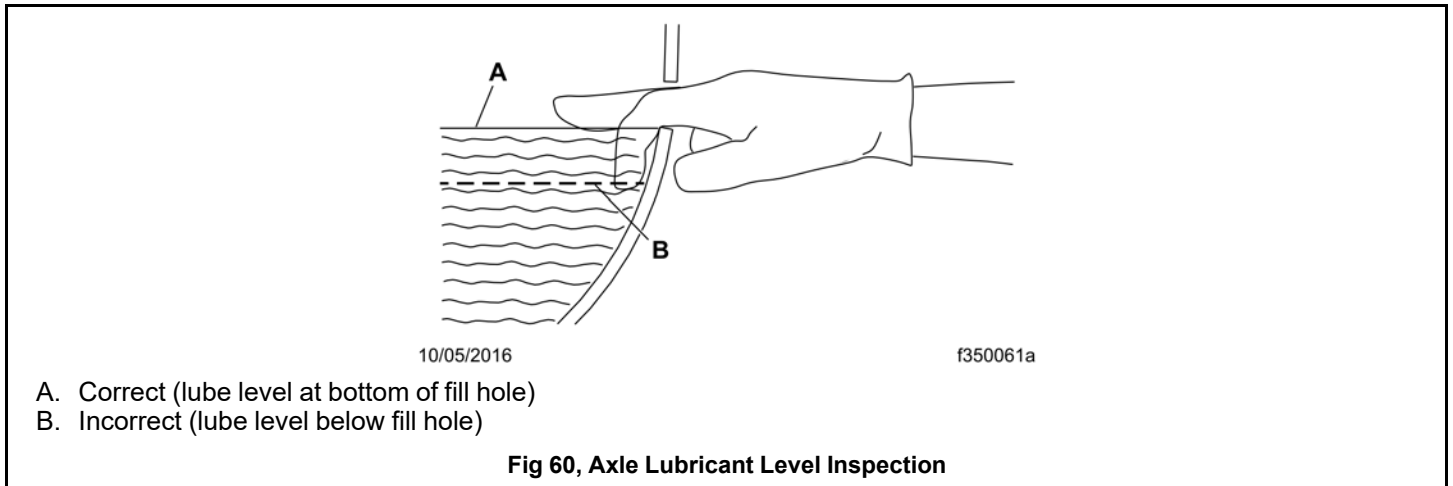

IMPORTANT: Lubricant used in Detroit rear axles must meet Mercedes-Benz specification 235.8 (synthetic). Mobil Delvac 1 Gear Oil 75W-90 meets this specification.

NOTE: A lubricant level close enough to be seen or touched is not sufficient. It must be level with the bottom of the fill hole.

NOTE: Detroit rear axles do not require the use of friction modifiers.

- 5. Install and tighten the fill plug 30 lbf·ft (41 N·m).

Type	Ambient Temperature	SAE Viscosity Grade
Synthetic Oil	-40°F (-40°C) and up ¹	75W-90

1. There is no upper limit on the ambient temperature.

Table 10, Detroit Drive Axle Lubricants

IMPORTANT: Always check the axle breather whenever checking the lubricant level. Check the breather more frequently under adverse operating conditions.

- 6. Check the axle housing breather. Make sure that it is open and unclogged. If the breather is plugged or damaged, clean or replace it as needed.

Axle	Oil Capacity: Quarts (liters)
Forward-Rear, Model 4	14.3 (13.5) ¹
Single and Rearmost Tandem, Model 4	10.6 (10.0) ¹
Single, Model 2	5.8 (5.5) ¹

1. These values assume the wheel ends are properly lubricated. Actual oil capacity might vary slightly depending on gear ratio.

Table 11, Detroit Rear Axle Lubricant Capacity (Hubs Full)

13.02.02 Meritor

- Clean the oil fill hole plug located in the carrier or the side of the axle housing and the area surrounding it. See Fig. 61, [Fill Hole Plug and Axle Housing Breather Locations](#). Remove the plug.

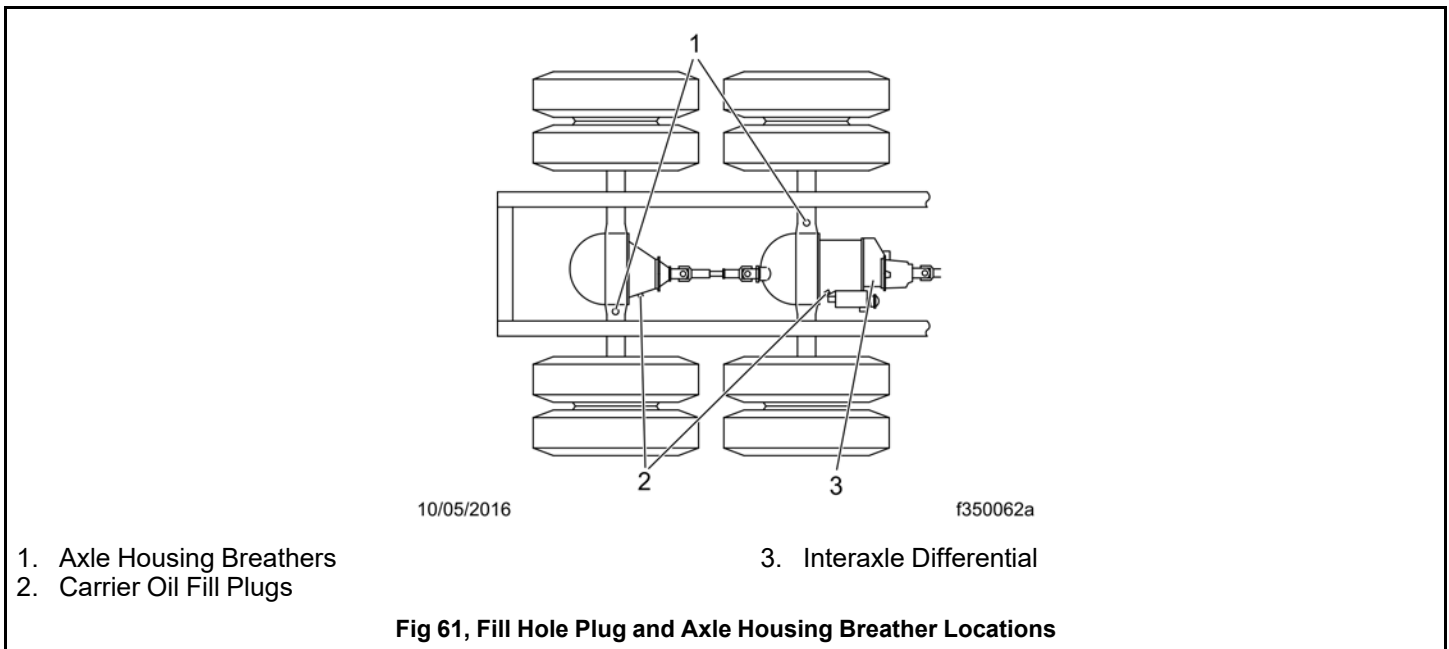

NOTE: Some Meritor axles have a small tapped and plugged hole located below the housing oil fill hole. This smaller hole is for the lubricant temperature sensor only and must not be used as a fill or level hole.

- When the vehicle is on level ground, the lubricant must be level with the bottom of the oil fill hole. If low, add lubricant. See Table 26, [Meritor Drive Axle Recommended Lubricant](#) for approved axle lubricants and see Table 27, [Meritor Drive Axle Lubricant Capacities for Single Axles](#) or Table 28, [Meritor Drive Axle Lubricant Capacities for Tandem Axles](#) for axle capacities.

Lubricant Type	Ambient Temperature	Viscosity Grade	Meritor Specification
Hypoid Gear Oil API Service Classification GL-5	10°F (-12.2°C) and up ¹	85W-140	0-76-A

Table 26, Meritor Drive Axle Recommended Lubricant

Lubricant Type	Ambient Temperature	Viscosity Grade	Meritor Specification
	-15°F (-26.1°C) and up ¹	80W-90	0-76-D
	-40°F (-40°C) and up ¹	75W-90	0-76-E
	-40°F (-40°C) to 35°F (2°C)	75W	0-76-J
	-40°F (-40°C) and up ¹	75W-140	0-76-L
Synthetic Gear Oil	-40°F (-40°C) and up ¹	75W-90	0-76-N
	-40°F (-40°C) and up ¹	75W-140	0-76-M

1. There is no upper limit on the ambient temperature.

Table 12, Meritor Drive Axle Recommended Lubricant

Axle Model	Capacity: pt (L) ¹
MS-10-113D	14 (6.6)
MS-12-113D	15 (7.1)
RS-13-120	18.4 (8.7)
RS-15-120	14.3 (6.8)
RS-17-145	33.6 (15.9)
RS-17-144	32.3 (15.3)
RS-19-144	32.3 (15.3)
RS-19-145	33.2 (15.7)
RS-21-145	32.3 (15.3)
RS-21-160	39.5 (18.7)
RS-21-230	38.9 (18.4)
RS-23-160	39.5 (18.7)
RS-23-161	39.5 (18.7)
RS-23-186	47.3 (22.4)
RS-23-240	37.4 (17.7)
RS-26-185	38.0 (18.0)
RS-30-185	38.0 (18.0)

1. Quantities listed are approximate and include 1 pint (0.5 liter) for each wheel end and with the drive pinion at 3 degrees.

Table 13, Meritor Drive Axle Lubricant Capacities for Single Axles

Axle Model	Axle Position	Capacity ¹
RT-40-145	Forward	30.2 (14.3)
	Rear	25.8 (12.2)
RT-40-145P	Forward	30.2 (14.3)
	Rear	25.8 (12.2)
RT-40-160	Forward	39.1 (18.5)

Table 28, Meritor Drive Axle Lubricant Capacities for Tandem Axles

Axle Model	Axle Position	Capacity ¹
	Rear	34.4 (16.3)
RT-44-145 RT-44-145P	Forward	29.3 (13.9)
	Rear	25.1 (11.9)
RT-46-160	Forward	39.1 (18.5)
	Rear	34.4 (16.3)

1. Quantities listed are approximate and include 1 pint (0.5 liter) for each wheel end and with the drive pinion at 3 degrees.

Table 14, Meritor Drive Axle Lubricant Capacities for Tandem Axles

13.03 Axle Breather Checking

The axle housing breather must remain clean. See Fig. 62, [Fill Hole Plug and Axle Housing Breather Locations](#). When the axle lubricant level is checked, check that the axle breather is open. Check more often under poor operating conditions. If the breather is plugged, clean it or replace it as needed.

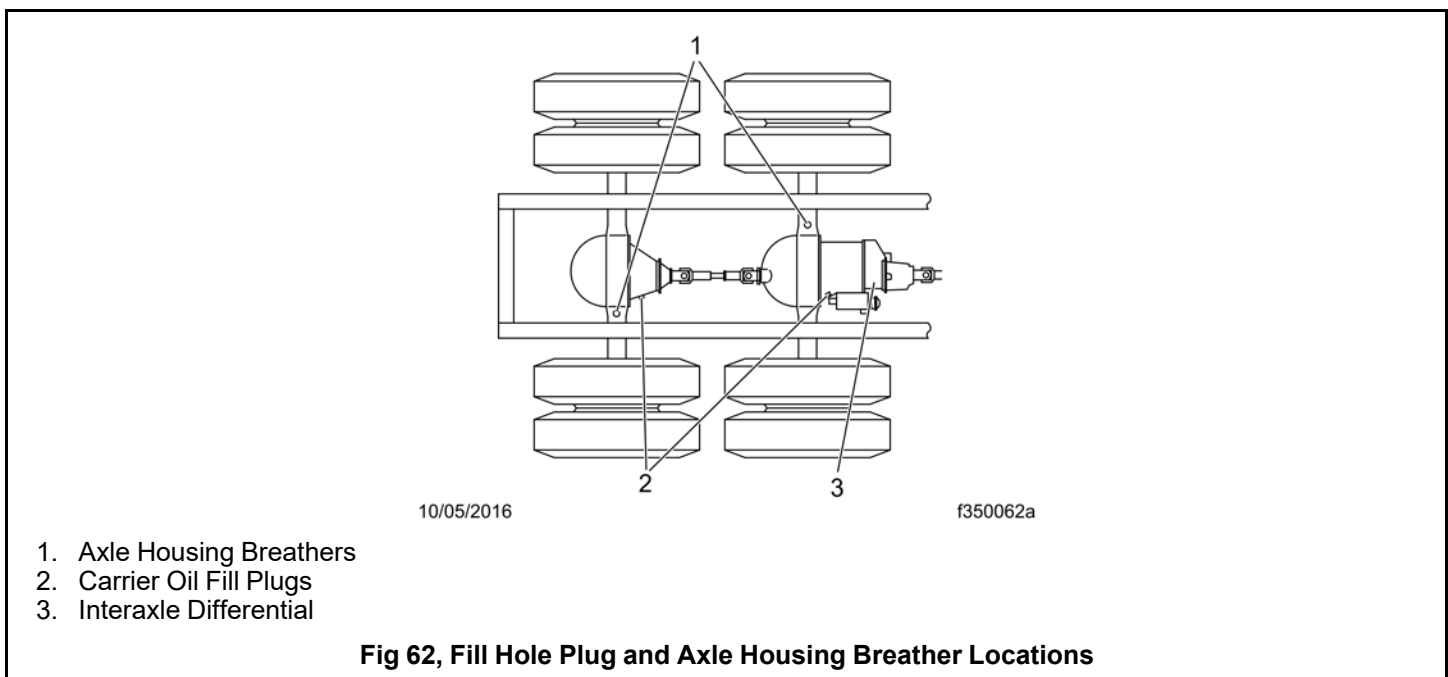

13.04 Axle Lubricant Changing and Magnetic Plug Cleaning

13.04.01 General Information

A regular schedule for changing the axle lubricant in a particular vehicle and operation can be accurately determined by analyzing oil samples taken from the axle at specified intervals or mileages. Lubricant suppliers frequently make their laboratory facilities available for determining the useful life of their product under actual service conditions. The final schedule that is recommended may, for economic reasons, be related to lubricant changes that are governed by climatic conditions and magnetic plug maintenance. Change lubricant type and viscosity as climatic temperatures demand, regardless of vehicle mileage or established change schedule.

The normal operating temperature of compounded lubricants during the summer season is about 160 to 220°F (71 to 104°C). The chemicals and additives that give these lubricants increased load carrying capacity oxidize faster at temperatures

above 220°F (104°C), contributing to more rapid lubricant deterioration. For this reason lubricants of this type that operate continuously at high temperatures must be changed more frequently.



NOTICE:

Failure to change the axle lubricant at more frequent intervals, when adverse operating conditions require, could result in axle damage.

13.04.02 Detroit®

IMPORTANT: On Detroit axles, the oil change interval for long haul vehicles can be extended to 500,000 miles (800 000 km) for axles with weight ratings of 34,000 to 40,000 lb (15 000 to 18 000 kg) using synthetic lubricant if a lubricant analysis shows adequate quality. Oil must be changed at least every four years, and more often if the axle is exposed to high temperatures and steep grades.

1. Park the vehicle on a level surface, shut down the engine, and set the parking brake. Chock the tires.
2. Clean the fill plug and the area around it. In the axle housing rear cover, remove the plug from the oil fill hole. See Fig. 63, [Detroit Tandem Axle \(forward axle shown\)](#).

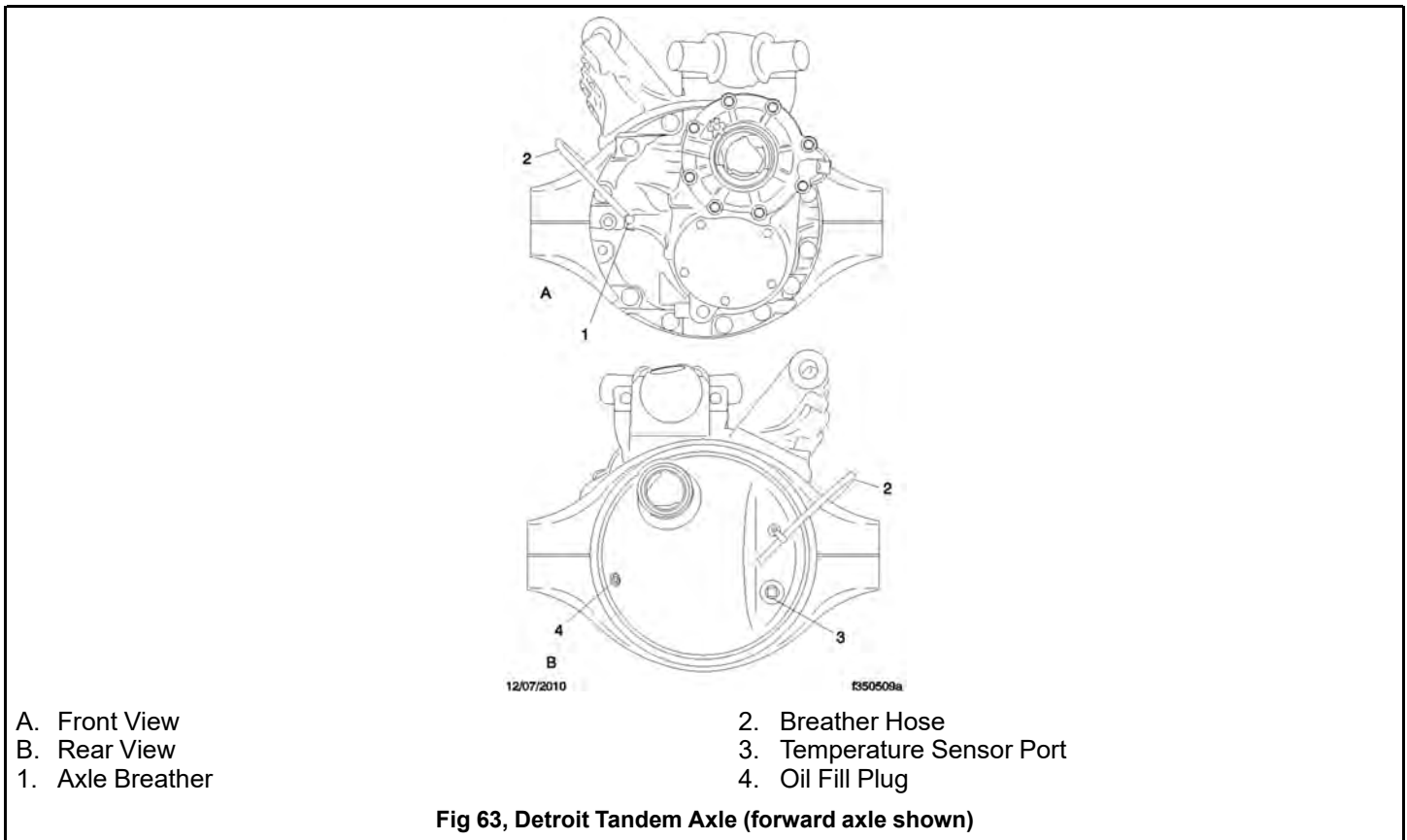

**CAUTION:**

Be careful when draining the axle oil. It may be very hot, and could cause personal injury if it contacts the skin.

3. Place a drain pan under the rear axle drain plug. Drain the oil when it is warm. At this temperature, the oil will run more freely and ensure that the axle is flushed.
4. Clean the fill and drain plugs. Change them if necessary.
 - 4.a For magnetic plugs, use a piece of key stock or any other convenient steel slug to short the two magnetic poles and divert the magnetic field.
 - 4.b Clean away the collected material deposited on each pole. Magnets will rapidly lose their effectiveness as collected material bridges the gap between the two poles.
 - 4.c After the first oil is changed, inspect the drain plug each time for large quantities of metal particles.
 - 4.d After cleaning, install the drain plug(s) and tighten to 30 lbf·ft (41 N·m).

IMPORTANT: Lubricant used in Detroit rear axles must meet Mercedes-Benz specification 235.8 (synthetic). Mobil Delvac 1 Gear Oil 75W-90 meets this specification.

NOTE: Some Detroit axles have a small tapped and plugged hole near and below the housing oil fill hole. This smaller hole is for a lubricant temperature indicator only, and should not be used as a fill or level hole.

NOTE: Detroit rear axles do not require the use of friction modifiers.

5. Fill the axle with the recommended lubricant. See Table 29, [Detroit Drive Axle Lubricants](#) for recommended lubricants, and see Table 30, [Detroit Rear Axle Lubricant Capacity \(Hubs Full\)](#) for lubricant capacities.

Type	Ambient Temperature	SAE Viscosity Grade
Synthetic Oil	-40°F (-40°C) and up ¹	75W-90

1. There is no upper limit on the ambient temperature.

Table 15, Detroit Drive Axle Lubricants

Axle	Oil Capacity: Quarts (liters)
Forward-Rear, Model 4	14.3 (13.5) ¹
Single and Rearmost Tandem, Model 4	10.6 (10.0) ¹
Single, Model 2	5.8 (5.5) ¹

1. These values assume the wheel ends are properly lubricated. Actual oil capacity might vary slightly depending on gear ratio.

Table 16, Detroit Rear Axle Lubricant Capacity (Hubs Full)

5.a Fill the axle through the oil fill hole. Lubricant should be level with the bottom of the oil fill hole. To check fluid level, see Fig. 64, [Axle Lubricant Level Inspection](#).

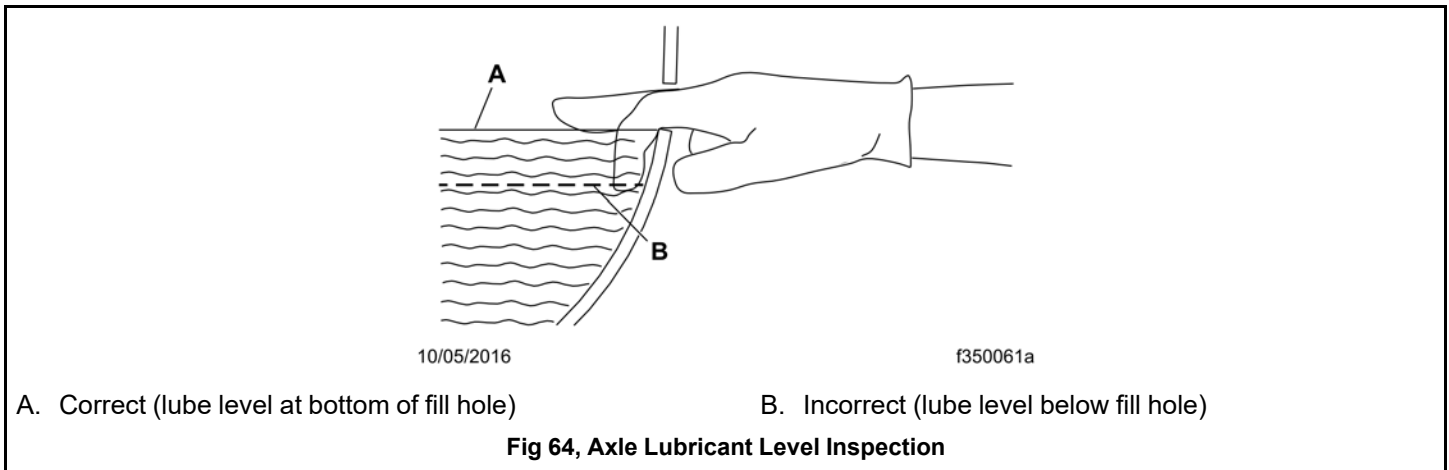

5.b Install and tighten the fill plug 30 lbf·ft (41 N·m).

13.04.03 Meritor

Axle Draining

1. Remove the plug at the bottom of the housing and drain the lubricant while the unit is warm. Allow enough time for all the old lubricant to drain completely.
2. Clean the drain plugs. For magnetic drain plugs, a piece of key stock or any other convenient steel slug may be used to short the two magnetic poles and divert the magnetic field.

NOTE: Meritor recommends using magnetic plugs with elements having a minimum pickup capacity of two pounds (one kilogram) of low-carbon steel in plate or bar form. Magnets will rapidly lose effectiveness as collected material bridges the gap between the two poles. Clean or change the plugs before this occurs. It may be necessary to clean or change the plugs one or more times between lubrication change intervals.

- After cleaning the drain plugs, install and tighten the plugs 35 lbf·ft (47 N·m).

Axle Filling

- With the vehicle on a level surface, fill the axle housings to the bottom of the oil fill hole (in the carrier or housing) with lubricant. See Table 31, [Meritor Drive Axle Recommended Lubricant](#) for approved axle lubricants, and Table 32, [Meritor Drive Axle Lubricant Capacities for Single Axles](#) or Table 33, [Meritor Drive Axle Lubricant Capacities for Tandem Axles](#) for axle capacities.

Lubricant Type	Ambient Temperature	Viscosity Grade	Meritor Specification
Hypoid Gear Oil API Service Classification GL-5	10°F (-12.2°C) and up ¹	85W-140	0-76-A
	-15°F(-26.1°C) and up ¹	80W-90	0-76-D
	-40°F(-40°C) and up ¹	75W-90	0-76-E
	-40°F(-40°C) to 35°F (2°C)	75W	0-76-J
	-40°F (-40°C) and up ¹	75W-140	0-76-L
Synthetic Gear Oil	-40°F (-40°C) and up ¹	75W-90	0-76-N
	-40°F (-40°C) and up ¹	75W-140	0-76-M

- There is no upper limit on the ambient temperature.

Table 17, Meritor Drive Axle Recommended Lubricant

Axle Model	Capacity: pt (L) ¹
MS-10-113D	14 (6.6)
MS-12-113D	15 (7.1)
RS-13-120	18.4 (8.7)
RS-15-120	14.3 (6.8)
RS-17-145	33.6 (15.9)
RS-17-144	32.3 (15.3)
RS-19-144	32.3 (15.3)
RS-19-145	33.2 (15.7)

Table 32, Meritor Drive Axle Lubricant Capacities for Single Axles

Axle Model	Capacity: pt (L) ¹
RS-21-145	32.3 (15.3)
RS-21-160	39.5 (18.7)
RS-21-230	38.9 (18.4)
RS-23-160	39.5 (18.7)
RS-23-161	39.5 (18.7)
RS-23-186	47.3 (22.4)
RS-23-240	37.4 (17.7)
RS-26-185	38.0 (18.0)
RS-30-185	38.0 (18.0)

1. Quantities listed are approximate and include 1 pint (0.5 liter) for each wheel end and with the drive pinion at 3 degrees.

Table 18, Meritor Drive Axle Lubricant Capacities for Single Axles

Axle Model	Axle Position	Capacity: pt (L) ¹
RT-40-145	Forward	30.2 (14.3)
	Rear	25.8 (12.2)
RT-40-145P	Forward	30.2 (14.3)
	Rear	25.8 (12.2)
RT-40-160	Forward	39.1 (18.5)
	Rear	34.4 (16.3)
RT-44-145 RT-44-145P	Forward	29.3 (13.9)
	Rear	25.1 (11.9)
RT-46-160	Forward	39.1 (18.5)
	Rear	34.4 (16.3)

1. Quantities listed are approximate and include 1 pint (0.5 liter) for each wheel end and with the drive pinion at 3 degrees.

Table 19, Meritor Drive Axle Lubricant Capacities for Tandem Axles

NOTE: Some Meritor axles have a small tapped and plugged hole located below the housing oil fill hole. This smaller hole is for the lubricant temperature sensor only and must not be used as a fill or level hole.

2. Install the fill hole plug and tighten it 35 lbf·ft(47 N·m).

3. After filling the carrier and housing assembly with lubricant, drive the vehicle unloaded for one or two miles (two or three kilometers) at speeds not to exceed 25 mph (40 km/h) to thoroughly circulate the lubricant throughout the assembly.

14.01 Wheel Nut Checking 124

14.02 Tire Check 125

14. Wheels and Tires

14.01 Wheel Nut Checking

IMPORTANT: In addition to the maintenance interval in this manual, check the wheel nut torque the first 50 to 100 miles (80 to 160 km) of operation after a wheel has been removed and installed.

When checking wheel nuts on a stud-piloted dual disc assembly, remove one outer nut at a time, tighten the inner nut, then reinstall the outer nut. Repeat this procedure for all of the inner wheel nuts in the sequence shown in Fig. 65, [Wheel Nut Tightening Sequence](#), then tighten all of the outer wheel nuts in the same sequence.

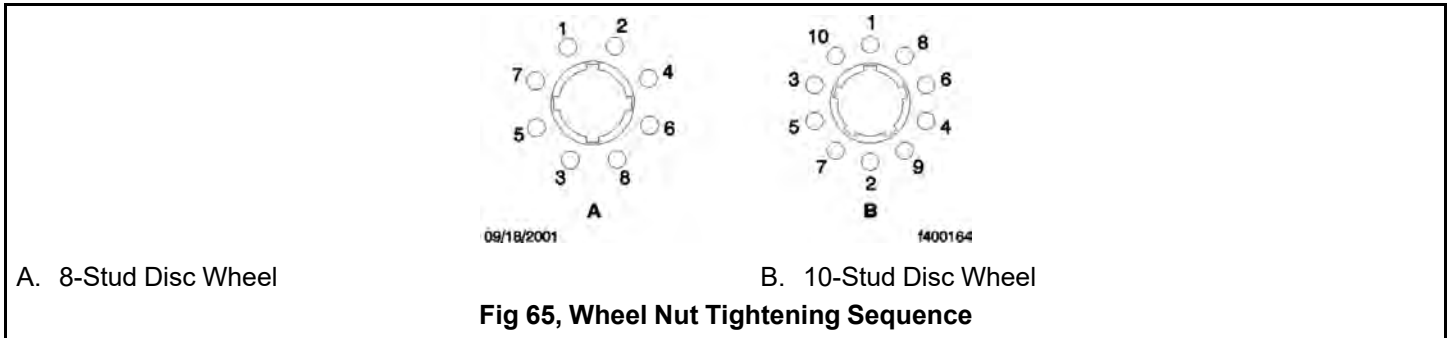

CAUTION:

Too little wheel nut torque can cause wheel shimmy, resulting in wheel damage, stud breakage, and extreme tire tread wear. Too much wheel nut torque can break studs, damage threads, and crack discs in the stud hole area.

See Table 34, [Wheel Nut Torque Specifications](#) for wheel nut torque specifications and see Fig. 65, [Wheel Nut Tightening Sequence](#) for the tightening sequence.

Thread Size	Wheel Manufacturer	Torque (oiled): lbf-ft (N·m)
M20 x 1.5	Accuride Corporation	280 to 330 (380 to 447)
	Alcoa Incorporated	
M22 x 1.5	Accuride Corporation	450 to 500 (610 to 678)
	Alcoa Incorporated	
1-1/8-16	Accuride Corporation	450 to 500 (610 to 678)
	Alcoa Incorporated	
3/4-16	Accuride Corporation	450 to 500 (610 to 678)
	Alcoa Incorporated	

14.02 Tire Check

Tires should be inspected closely during the first 3000 to 10,000 miles (5000 to 16 000 km) for abnormal wear.

Maintain the proper pressures for carried loads, per the tire manufacturers' recommendations, or the tire pressure label on the driver's door.

Have the wheel alignment checked after the first 10,000 miles (16 000 km), then every 40,000 miles (60 000 km) thereafter.

Do not continue to drive the vehicle if tires develop any of the following:

- blisters;
- cuts or punctures that reach to the cord;
- a nail, screw, rock, or other puncturing object;
- flat spots or irregular wear;
- tread worn to a minimum depth;
- inability to maintain proper tire pressure.

15.01 Safety Precautions	128
15.02 Driveline Inspecting	128
15.03 Driveline Lubricating	129

15. Driveline

15.01 Safety Precautions

Safety Precautions in this section apply to all procedures within this group.



DANGER:

When working on the vehicle, shut down the engine or motor, set the parking brake, and chock the tires. Before working under the vehicle, always place jack stands under the frame rails to ensure the vehicle cannot drop. Failure to follow these steps could result in serious personal injury or death.

15.02 Driveline Inspecting



WARNING:

Do not service or inspect a driveshaft with the engine running. A rotating driveshaft can cause serious personal injury.

Loose end yokes, excessive radial looseness, slip spline radial looseness, bent shaft tubing, or missing plugs in the slip yoke can cause universal joint and bearing defects.

See Fig. 66, [Full-Round Driveline](#) for an illustration of the ArvinMeritor™ Full-Round driveline. See Fig. 67, [Easy Service \(1/2 Round\) Driveline](#) for an illustration of the ArvinMeritor™ Easy Service™ or 1/2 Round driveline.

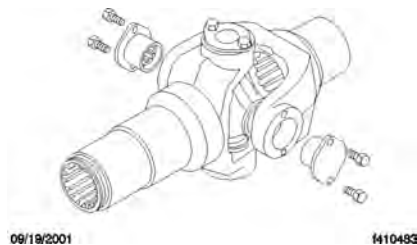

Fig 66, Full-Round Driveline

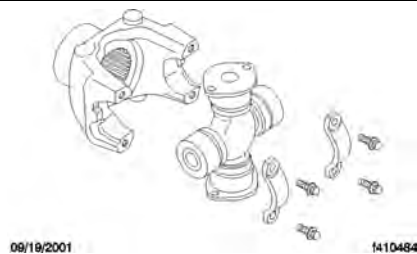

Fig 67, Easy Service (1/2 Round) Driveline

1. Check the output and input end yokes on both the transmission and axle for axial looseness. Refer to the axle or transmission manufacturer's service information for the correct specifications.

If loose, disconnect the driveshaft. For instructions, see [General Information, Driveline Components](#) in the *108SD Plus and 114SD Plus Workshop Manual*. Tighten the end yoke retaining nut to the proper specification. Refer to the axle or transmission manufacturer's service information for the correct specifications.

2. Inspect for worn universal joints. Apply a vertical force of about 50 pounds to the driveline near the universal joints. If there is any movement, replace the universal joint. For instructions, see [General Information, Driveline Components](#) in the *108SD Plus and 114SD Plus Workshop Manual*
3. Examine the slip yoke spline for excessive radial movement. See Fig. 68, [Examine the Slip Yoke Spline](#). If excessive radial looseness exists between the slip yoke and the tube shaft, replace the slip yoke and the tube shaft. For instructions, see [General Information, Driveline Components](#) in the *108SD Plus and 114SD Plus Workshop Manual*

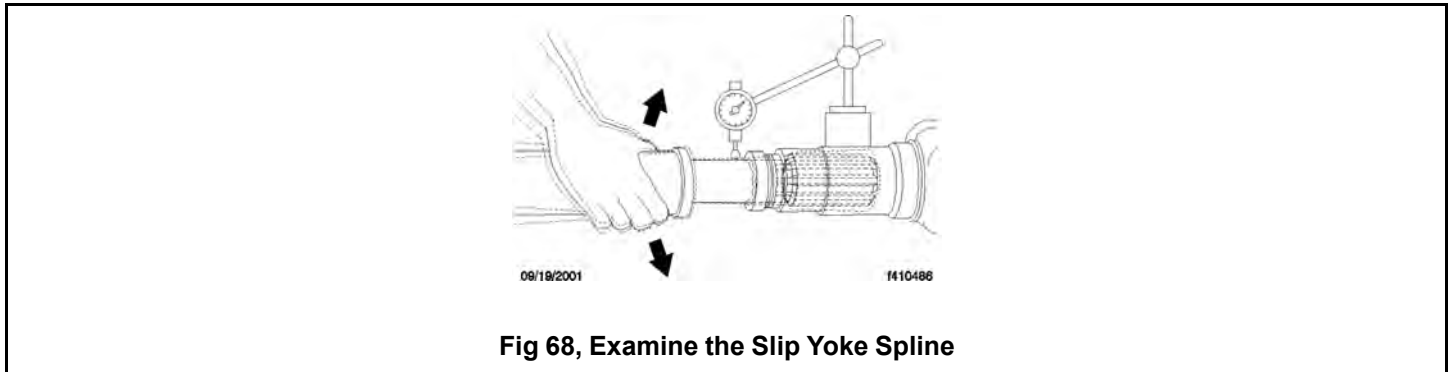

Fig 68, Examine the Slip Yoke Spline

4. Examine the shaft for damaged or bent tubing. Carefully remove any foreign material, such as mud or dirt on the shaft.

15.03 Driveline Lubricating

The Full-Round and Easy Service drivelines require periodic lubrication of the universal joints and slip yoke splines. See Fig 69, [Lubrication Areas for Full-Round and Easy Service Drivelines](#) for the areas that need lubrication. See Table.35, [Approved Lubricants](#) for approved lubricants.

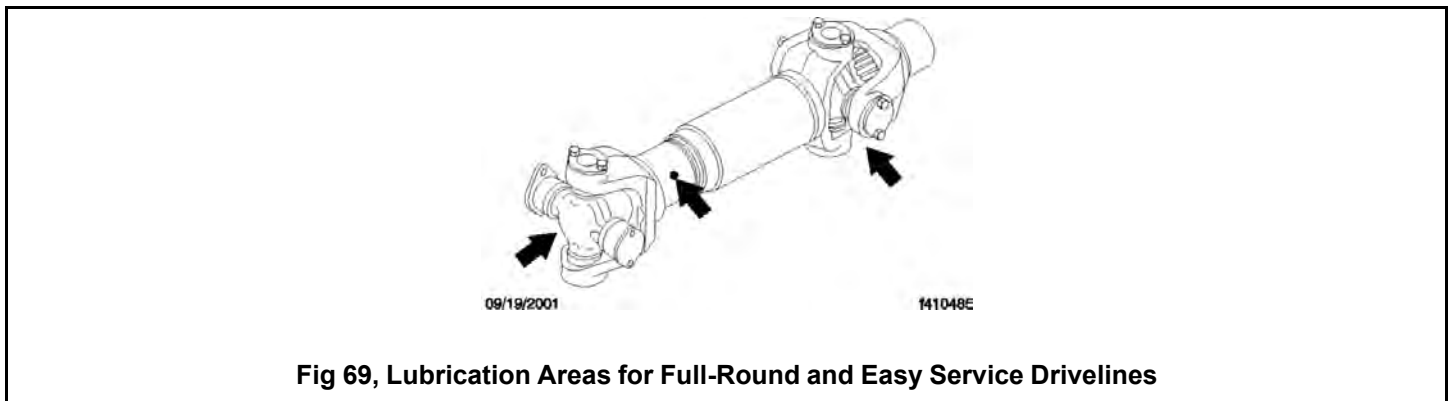

Fig 69, Lubrication Areas for Full-Round and Easy Service Drivelines

Lubricant and Specification	Lubricant Brands
Universal joint, slip joint, and spline grease must meet ArvinMeritor Specification O-634-B (NLGI Grade No. 2, Lithium 12-Hydroxy Stearate with Molybdenum Disulfide)	Phillips Petroleum Philube MW-EP2 Grease
	Exxon 5160
	Amalie All Purpose Grease with Moly-L1-2M

Table 35, Approved Lubricants

Lubricant and Specification	Lubricant Brands
	Shell Super Duty Special FF
	Marathon Maralube Molycode 529
	Shell Moly Poly Grease
	Kendall L424 Grease
	Amoco Super Chassis Grease
	Ford Specification M1C-75B or part number PN™C1AZ 19590

16.01 Safety Precautions	132
16.02 Air Brake System Valve Inspection.....	132
16.03 Bendix Air Dryer Desiccant Replacement	132
16.03.01 AD-9	132
16.03.02 AD-IP	135
16.03.03 AD-9si and AD-IS	136
16.04 Governor D-2A Check.....	137
16.04.01 Operational Test.....	137
16.05 Bosch Hydraulic Brake System Inspection.....	138
16.06 Dana Spicer, Haldex, and Gunite Slack Adjuster Lubrication.....	138
16.06.01 Dana Spicer and Haldex	138
16.06.02 Gunite	141
16.07 Meritor Camshaft Bracket Lubrication	143
16.08 Meritor Slack Adjuster Lubrication.....	144
16.09 Air Dryer AD-9, AD-IP, and AD-IS/DRM Check	146
16.09.01 Air Dryer AD-9, AD-IP, AD-IS/DRM Check Procedure	146
16.09.02 Operational and Leakage Tests	146
16.10 Bendix E-6 Foot Control Valve Inspection and Lubrication	147
16.11 Brake Inspection.....	148
16.11.01 Parking Brake Operational Check.....	148
16.11.02 Brake Component Inspection	149
16.12 Hydro-Max™ Brake System Inspection	155
16.13 Replacement of the WABCO System Saver Air Dryer Desiccant Cartridge.....	156
16.14 Versajust Slack Adjuster Inspection and Lubrication.....	157
16.14.01 Inspection Procedure	157
16.14.02 In Service Inspection	157

16. Brakes

16.01 Safety Precautions

Safety Precautions in this section apply to all procedures within this group.

**DANGER:**

When working on the vehicle, shut down the engine or motor, set the parking brake, and chock the tires. Before working under the vehicle, always place jack stands under the frame rails to ensure the vehicle cannot drop. Failure to follow these steps could result in serious personal injury or death.

16.02 Air Brake System Valve Inspection

IMPORTANT: There is no scheduled (Bendix) air valve maintenance that requires disassembly of the valve within the warranty period. If the valve does not function within the warranty period, do not disassemble the part as this will void the warranty.

See the following maintenance operations for information about Bendix air valve maintenance.

16.03 Bendix Air Dryer Desiccant Replacement

16.03.01 AD-9

IMPORTANT: For vehicles equipped with an oil-coalescing air dryer desiccant cartridge, replace the cartridge once a year, regardless of mileage.

1. Park the vehicle on a level surface, apply the parking brakes, and chock the tires.
2. Completely drain all air reservoirs. Air pressure gauges should read 0 psi (0 kPa).

NOTE: The compressor discharge line may still contain residual air pressure, open the line slowly.

3. Identify, tag, and disconnect the three air lines from the end cover.
4. Disconnect the harness connector from the heater and thermostat assembly.
5. Loosen the bolt that secures the upper mounting bracket strap.
6. Remove the two bolts and Nylok® nuts that secure the air dryer to the lower mounting bracket. Mark the position of the mounting bracket to the end cover and mark the bolts to ease installation.
7. Remove the upper mounting bracket strap fasteners, then remove the strap and the air dryer.
8. Place the air dryer on a bench and remove the remaining 6 bolts, 12 washers, 6 Nylok nuts, and the air dryer housing. See Fig. 70, [AD-9 Air Dryer \(exploded view\)](#). Discard the Nylok nuts. Remove the end-cover-to-housing O-ring.

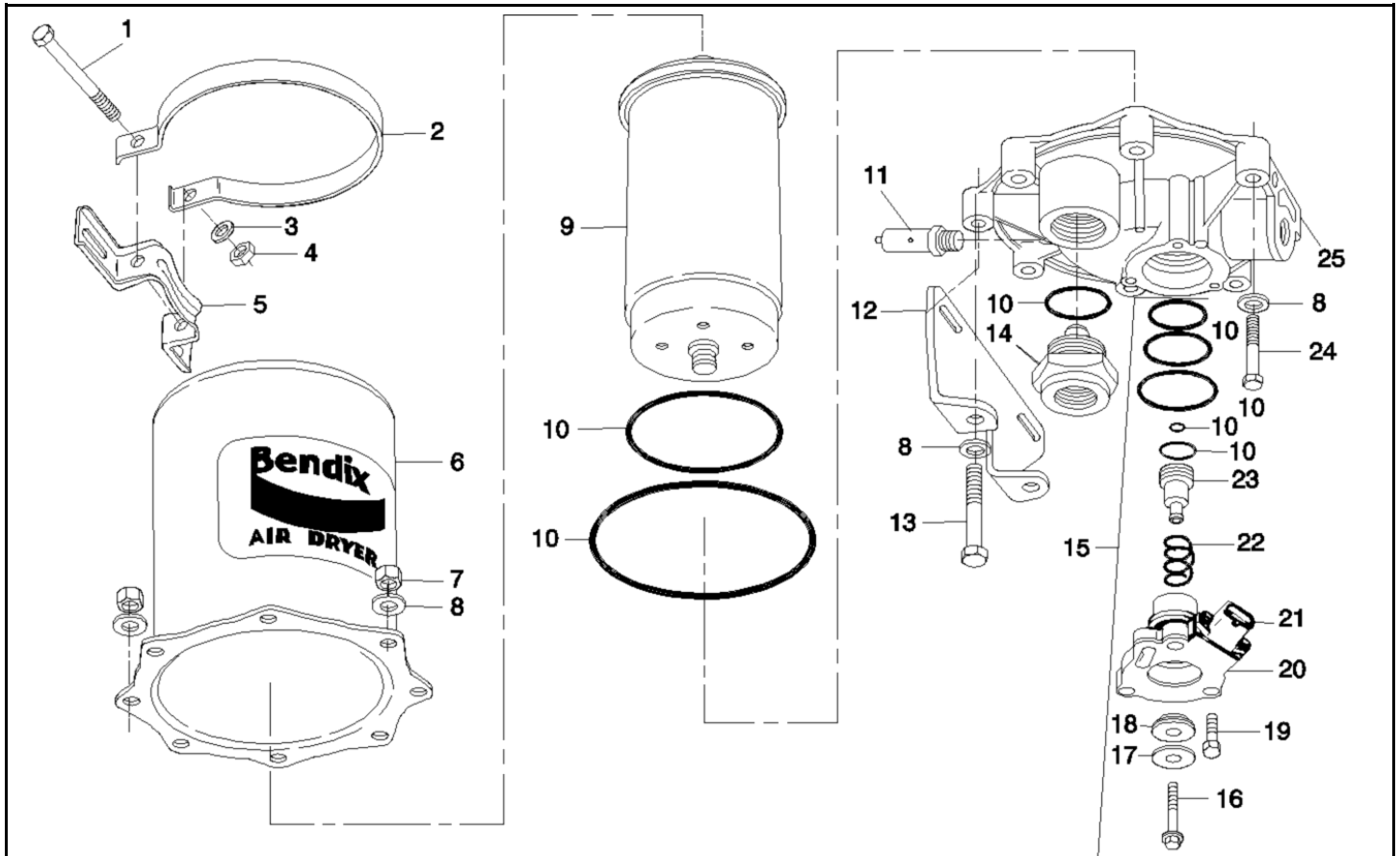

08/09/95

f421383

- | | |
|--|---|
| <ul style="list-style-type: none"> 1. 5/16 x 4-1/2 Upper Mounting Bracket Bolt 2. Upper Mounting Bracket Strap 3. Lockwasher 4. 5/16-Inch Nylok Nut 5. Upper Mounting Bracket 6. Housing 7. Nylok Nut 8. 3/8-Inch Special Washer 9. Desiccant Cartridge 10. O-Ring 11. Safety Valve 12. Lower Mounting Bracket 13. 3/8-Inch Bolt (long) | <ul style="list-style-type: none"> 14. Check Valve Assembly 15. Purge Valve Assembly 16. Purge Valve Capscrew 17. Exhaust Diaphragm 18. Purge Valve 19. 1/4-Inch Tapping Screw 20. Purge Valve Housing 21. Heater and Thermostat Housing 22. Return Spring 23. Purge Piston 24. 3/8-Inch Bolt 25. End Cover |
|--|---|

Fig 70, AD-9 Air Dryer (exploded view)

9. Clamp the desiccant cartridge in a vise.

**WARNING:**

Clamping the end cover or housing in a vise could seriously compromise the air dryer's ability to hold air pressure, which could cause a failure in the brake system, resulting in property damage, personal injury, or death.

10. Twist the end cover counterclockwise to release the cartridge from the end cover. Rotate the end cover until it completely separates from the desiccant cartridge.

**NOTICE:**

Dirt or obstructions in the O-ring grooves can cause an O-ring failure that will result in an air leak.

NOTE: A substantial torque, up to 50 lbf·ft (68 N·m), may be necessary to remove the desiccant cartridge.

11. Inspect the condition of the O-ring seals. If they are cracked, crimped, or otherwise damaged, replace them to ensure an airtight seal. Clean the O-ring grooves of any dirt or obstruction.
12. Lubricate the O-rings with silicone or lithium grease and install them in the end cover.
13. Install the desiccant cartridge on the end cover. Turn the cartridge clockwise until the desiccant cartridge makes contact with the end cover.
14. Place the desiccant cartridge in a vise, and turn the end cover clockwise an additional 180 to 225 degrees to fully tighten the desiccant cartridge to the end cover.

NOTE: Desiccant cartridge torque should not exceed 50 lbf·ft (68 N·m).

15. Place the housing over the desiccant cartridge and align the mounting holes with the end cover.

IMPORTANT: Replace, do not reuse the Nylok nuts on the air dryer cover.

16. Install the 6 bolts, 12 washers, and 6 new Nylok nuts. Torque the Nylok nuts in a star pattern 17 to 24 lbf·ft (23 to 33 N·m). See Fig. 71, [AD-9 End Cover to Housing Torque Pattern](#).

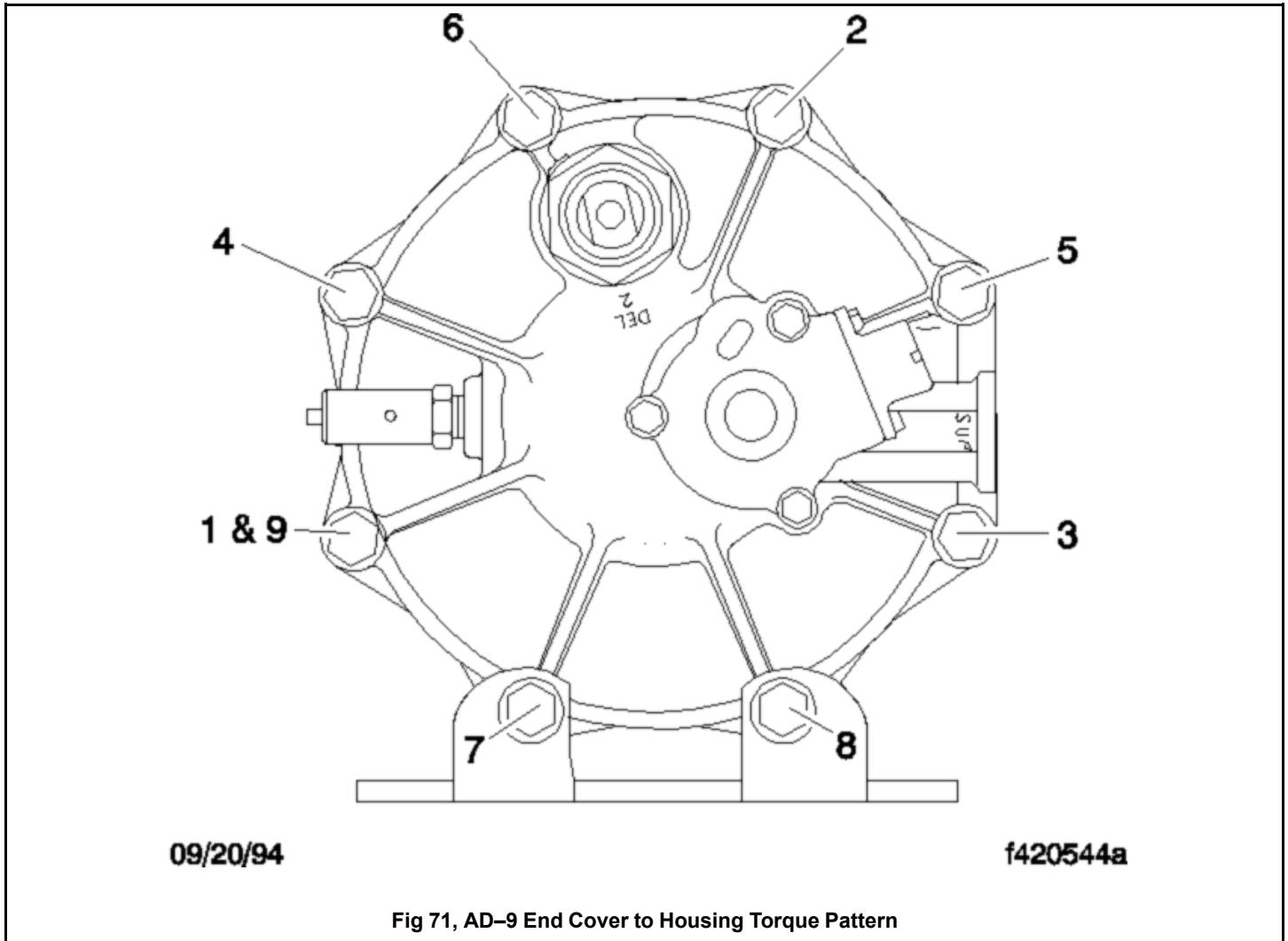

17. Install the air dryer on the lower mounting bracket. Install the two previously marked bolts, four washers, and two new Nylok nuts. Torque the two remaining Nylok nuts 17 to 24 lbf·ft (23 to 33 N·m). Install the bolt, two washers, and a new Nylok nut in the upper mounting bracket strap. Torque the upper mounting bracket strap Nylok nut 80 to 120 lbf·in (900 to 1360 N·cm).
18. Connect and tighten the three air lines. Connect the harness connector to the heater and thermostat assembly until the lock tab snaps in place.
19. Start the engine, build the air pressure, and check the air brake system for leaks. If any air leaks are present, see [General Information](#) in the *108SD Plus and 114SD Plus Workshop Manual* for diagnosis and repair information.

16.03.02 AD-IP

1. Park the vehicle on a level surface, apply the parking brakes, and chock the tires.
2. Using a wrench or a socket, loosen the desiccant cartridge bolt. Then separate the desiccant cartridge from the end cover.
3. Pull the cartridge bolt out of the cover and remove the cartridge.

**WARNING:**

Do not attempt to disassemble the desiccant cartridge assembly. Parts for the assembly are not available and the cartridge contains a 150 lb spring that cannot be mechanically caged. Disassembly could release the spring, resulting in personal injury.

4. Remove and discard both O-rings from the cartridge bolt.
5. Using a clean rag, wipe clean the inside of the end cover. Clean the cartridge bolt bore in the end cover, and the sealing surfaces for the large- and small-diameter desiccant cartridge sealing rings.
6. Inspect the end cover for physical damage, then inspect all air line fittings for corrosion; replace as necessary.
7. Clean and inspect the bolt, paying attention to the threads and O-ring grooves.

IMPORTANT: Use only the grease supplied with Bendix replacement kits.

8. Lubricate the O-rings, bolt O-ring grooves, sealing rings, and cartridge grooves. Lubricate the end cover bore for the bolt.
9. Install both O-rings on the cartridge bolt, then, using a twisting motion, insert the assembled desiccant cartridge bolt in the end cover.
10. Install the desiccant cartridge on the end cover, making sure the cartridge is properly seated and flush on the end cover.

NOTE: It may be necessary to rotate the cartridge slightly until the anti-rotation lugs are properly aligned and allow the cartridge to rest flush against the end cover.

11. Using a wrench or socket, tighten the desiccant cartridge bolt 70 lbf·ft (95 N·m). **Do not** over-torque.
12. Before placing the vehicle in service, perform the test below.
 - 12.a Close all reservoir drain cocks.
 - 12.b Build system pressure to governor cut-out, and note that the AD-IP air dryer purges with an audible escape of air.
 - 12.c Fan the service brakes to reduce system air pressure to governor cut-in. Note that the system once again builds to full pressure and is followed by a purge at the AD-IP air dryer exhaust.
 - 12.d Check for excessive leakage around the head of the desiccant cartridge where it contacts the end cover. With the compressor in loaded mode (compressing air), apply a soapy solution to these areas, and observe that any leakage does not exceed a 1-inch bubble in 1 second. If leakage exceeds this measure, remove and re-install the desiccant cartridge.

16.03.03 AD-9si and AD-IS

1. Park the vehicle on a level surface, apply the parking brakes, and chock the tires.
2. Drain the air reservoirs.
3. Using a strap wrench or equivalent, loosen the desiccant cartridge. Spin the cartridge off by hand and discard it. See Fig. 72, [Desiccant Cartridge Replacement](#).

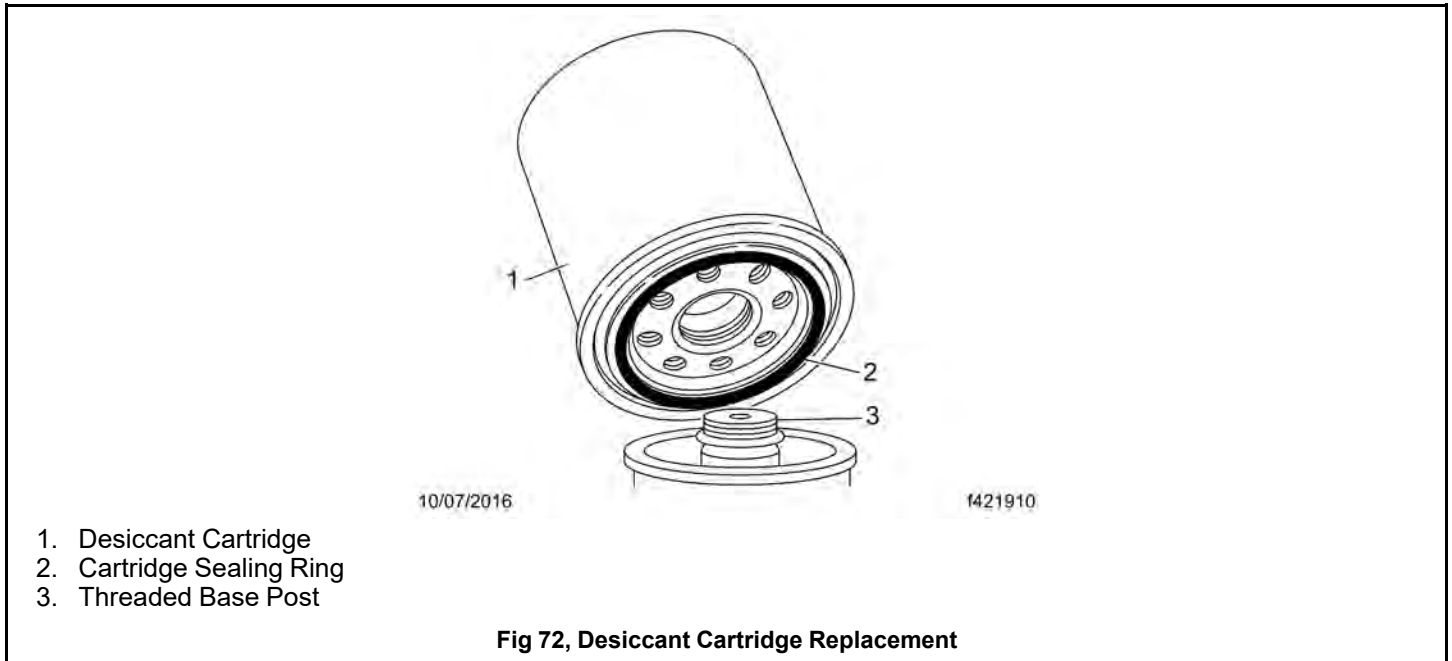

4. On the new desiccant cartridge, lubricate the sealing rings with silicone grease.

IMPORTANT: Only use the silicone grease supplied with Bendix replacement kits.

5. Screw the desiccant cartridge onto the body by hand until the seal makes contact with the body. Rotate the cartridge clockwise about one full turn. Tighten the cartridge firmly.

16.04 Governor D–2A Check

16.04.01 Operational Test

IMPORTANT: Review the warranty policy before performing any intrusive maintenance procedures. An extended warranty may be voided if intrusive maintenance is performed during this period.

Every 12 months, 100,000 miles (160 900 km), or 3600 operating hours, perform the operational test below:

1. Start the vehicle engine, build air pressure in the brake system, and check the pressure registered by a dash or test gauge at the time the governor cuts-out, stopping the compression of air by the compressor. Cut-out pressure should be in accordance with the pressure setting of the piece number being used. Common cut-out pressures are 125 to 135 psi (862 to 931 kPa). With the engine still running, make a series of brake applications to reduce the air pressure, and observe at what pressure the governor cuts-in the compressor. As in the case of cut-out pressure, cut-in pressure should be in accordance with the pressure setting of the piece number being used. Cut-in pressure is 105 psi (724 kPa).

NOTE: If the governor cover is marked nonadjustable, and the adjusting stem has been sheared off, this is a non-serviceable governor and it must be replaced with a new or remanufactured unit.

2. Never condemn or adjust the governor pressure settings unless they're checked with an accurate test gauge or a dash gauge that's registering accurately. If the pressure settings of the D-2 governor are inaccurate or it's necessary that they be changed, the adjustment procedure follows.
 - 2.a Remove the top cover from the governor.

- 2.b Loosen the adjusting screw locknut.
- 2.c To raise the pressure setting, turn the adjusting screw counterclockwise; to lower the setting, turn the screw clockwise. Be careful not to overadjust. Each 1/4 turn of the adjusting screw raises or lowers the pressure setting approximately 4 psi (28 kPa).
- 2.d When proper adjustment is obtained, tighten the adjusting screw locknut, and install the top cover. The pressure range between cut-in and cut-out is not adjustable.

Cut-In Position: Apply the soap solution around the cover and to the exhaust port. Slight bubble leakage is permitted. Excessive leakage indicates a faulty inlet valve or faulty lower piston O-ring.

Cut-Out Position: Apply the soap solution around the cover and to the exhaust port. Slight bubble leakage is permitted. Excessive leakage indicates a faulty exhaust valve seat, exhaust stem O-ring, or O-ring at the top of the piston. If the governor does not function as described, or if leakage is excessive, it is recommended that it be replaced with a new or remanufactured unit, or repaired with genuine Bendix parts.

16.05 Bosch Hydraulic Brake System Inspection

Before checking lining wear with the wheel removed, review the following brake lining exposure warnings.



WARNING:

Breathing brake lining dust (asbestos or non-asbestos) could cause lung cancer or lung disease. Unless exposure can be reduced below legal limits, wear an air purifying respirator approved by MSHA or NIOSH at all times when servicing the brakes, starting with removal of the wheels and continuing through assembly.

To minimize the possibility of creating airborne brake lining dust, clean the dust from the brake rotor, brake caliper, and brake assembly, using an industrial-type vacuum cleaner equipped with a high-efficiency filter system. Then, using a rag soaked in water and wrung until nearly dry, remove any remaining dust. Do not use compressed air or dry brushing to clean the brake assembly.

1. Check lining wear, as follows.
 - 1.a Apply the parking brakes. Chock the tires to prevent vehicle movement.
 - 1.b Remove one or more of the lining inspection plugs, and measure brake lining thickness.
 - 1.c On front and rear axles, replace linings worn to less than 1/16 inch (1.6 mm).
 - 1.d Make sure that the brake rotor and linings are free of oil and grease.
 - 1.e Install the inspection plug(s).
2. If the wheel and hub assembly is removed from the axle, check lining wear. Replace the linings on all brake assemblies if worn to less than 1/16 inch (1.6 mm) at the thinnest point. Check the brake pads for wear and replace, as necessary.

16.06 Dana Spicer, Haldex, and Gunitex Slack Adjuster Lubrication

16.06.01 Dana Spicer and Haldex

IMPORTANT: Perform a brake inspection before lubricating the camshaft bracket.

Automatic slack adjusters that have a grease fitting must be lubricated periodically to ensure proper brake operation.

**WARNING:**

Failure to lubricate slack adjusters could lead to dragging brakes or a brake failure, resulting in property damage, personal injury, or death.

**WARNING:**

Do not use moly-disulfide-loaded grease or oil. Both the life and reliability of the slack adjuster will be reduced if this type of grease is used, which could lead to brake failure, resulting in property damage, personal injury, or death.

Lubricate the automatic slack adjuster at the grease fitting. See Fig. 73, [Dana Spicer Automatic Slack Adjuster](#) for a Dana Spicer slack adjuster. Dana Spicer Low Lube slack adjusters should be lubricated with SHC 460 synthetic lubricant. See Fig. 74, [Haldex Automatic Slack Adjuster Grease Fitting](#) for a Haldex slack adjuster. Use standard chassis lubricant for Haldex slack adjusters.

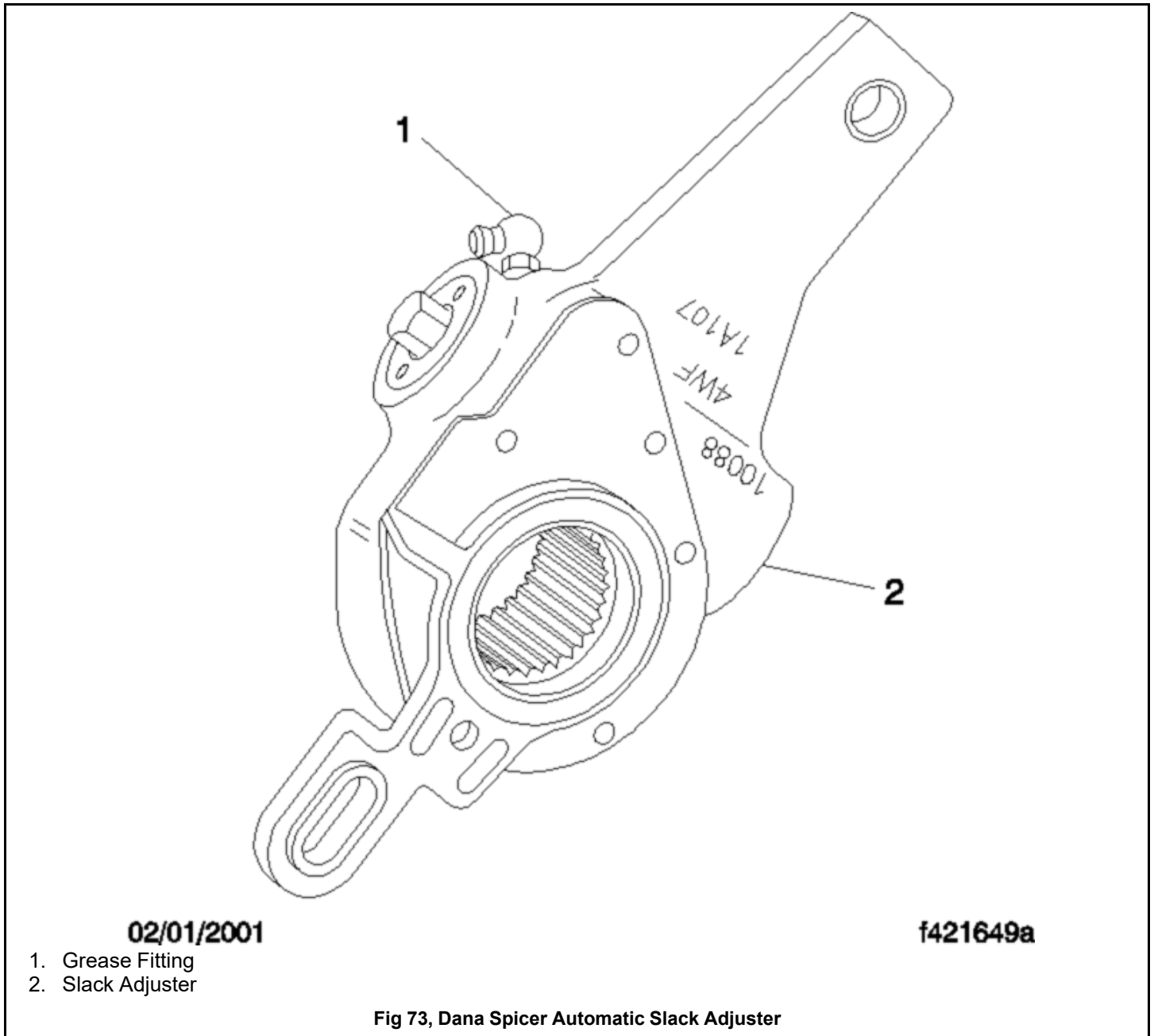

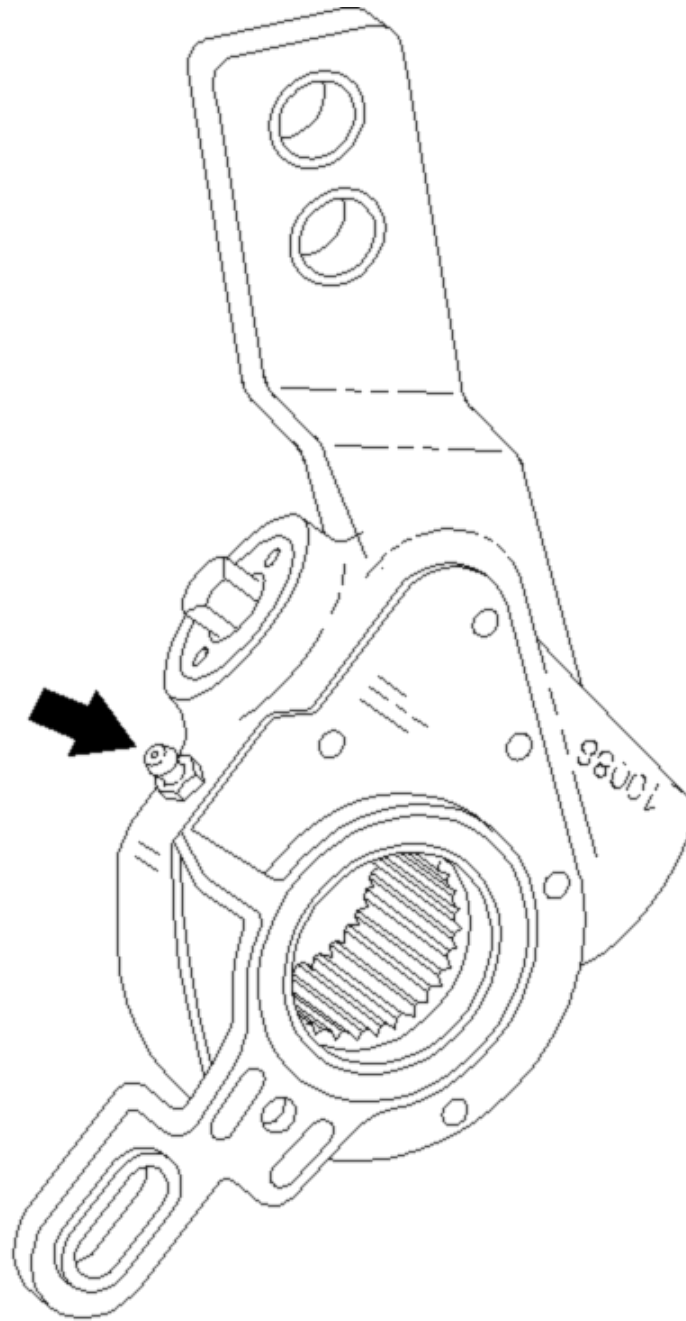

06/26/2007

f422363c

Fig 74, Haldex Automatic Slack Adjuster Grease Fitting

16.06.02 Gunite

IMPORTANT: Perform a brake inspection before lubricating the camshaft bracket.

Automatic slack adjusters that have a grease fitting must be lubricated periodically to ensure proper brake operation.

**WARNING:**

Failure to lubricate slack adjusters could lead to dragging brakes or a brake failure, resulting in property damage, personal injury, or death.

For operating temperatures of -20°F (-29°C) and higher, use Texaco Multifak EP-2 or Mobil Grease No. 77.

For operating temperatures between -20°F (-29°C) and -40°F (-40°C), use Lubriplate Aero grease.

Lubricate a Gunite automatic slack adjuster at the grease fitting until grease appears on the camshaft, or flows from the grease relief. See Fig. 75, [Gunite Automatic Slack Adjuster](#).

The newest Gunite automatic slack adjusters are produced without a grease relief. During lubrication with a grease gun, lubricant is forced through the drilled worm wheel onto the camshaft. Lubricate the automatic slack adjuster at the grease fitting until grease appears on the camshaft.

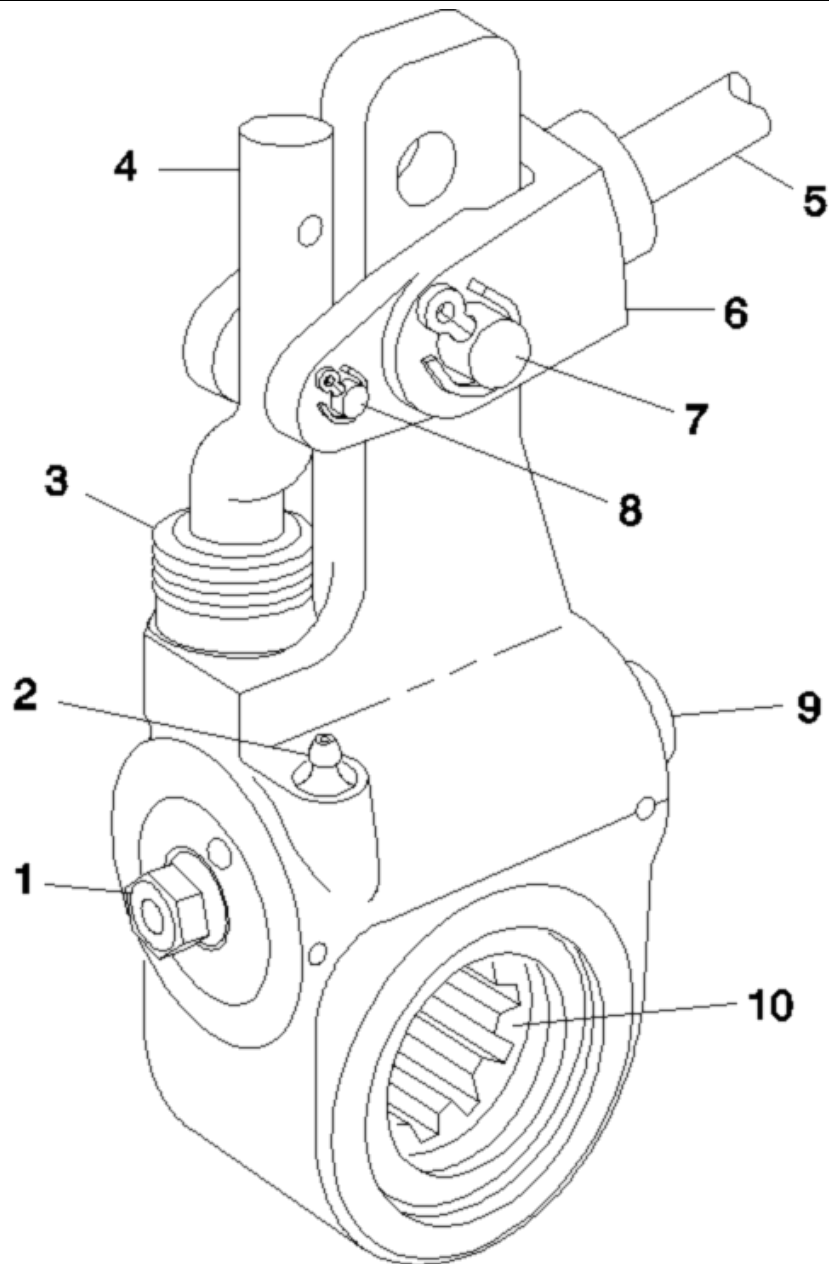

10/27/93

f420653a

1. 7/16-Inch Adjusting Nut
2. Grease Fitting
3. Boot
4. Link
5. Brake Chamber Piston Rod

6. Clevis
7. 1/2-Inch Clevis Pin
8. 1/4-Inch Clevis Pin
9. Grease Relief Opening
10. Slack Adjuster Spline

Fig 75, Gunite Automatic Slack Adjuster

16.07 Meritor Camshaft Bracket Lubrication

IMPORTANT: Replace the WABCO system saver air dryer desiccant cartridge before lubricating the camshaft brackets.

NOTE: If equipped with an extended-maintenance Q Plus™ brake system, the camshaft bracket will not have a grease fitting. These camshafts use a special NLGI grade synthetic polyurea grease, and do not require lubrication for 3 years or 500,000 miles (800 000 km), whichever comes first. Extended-maintenance camshaft bushings are lubricated during the brake reline service interval. For service and lubrication instructions, see [General Information](#) in the *108SD Plus and 114SD Plus Workshop Manual*.

For camshaft brackets with grease fittings, use an NLGI Grade 1 or Grade 2 multipurpose chassis grease.

Lubricate the camshaft bushings through the grease fitting on the camshaft bracket or the spider until new grease flows from the inboard seal. See Fig. 76, [Camshaft Bracket Lubrication](#).

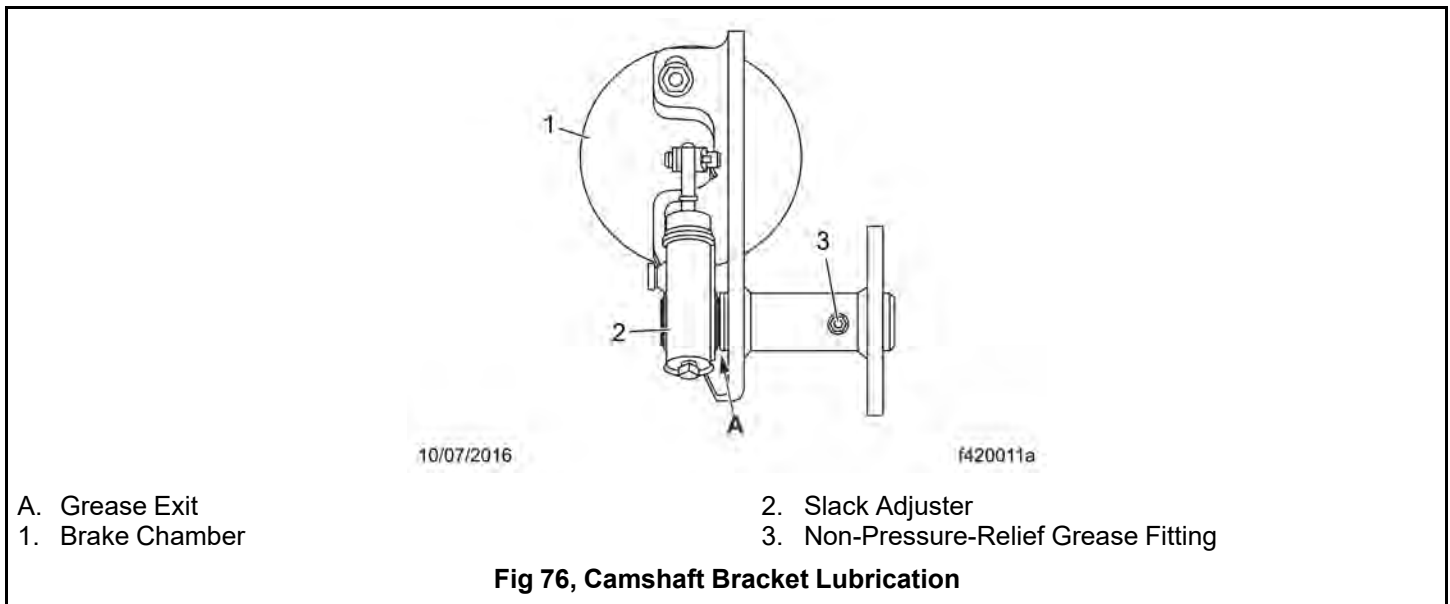

WARNING:

If grease leaks out under the camhead, the camshaft bracket grease seal is worn or damaged. See General Information in the *108SD Plus and 114SD Plus Workshop Manual* for grease seal replacement instructions. If this seal is not replaced, the brake linings could become contaminated with grease. The stopping distance of the vehicle will be increased, which could result in personal injury or property damage.

16.08 Meritor Slack Adjuster Lubrication

IMPORTANT: Perform a brake inspection following the instructions in this group before lubricating the slack adjusters.



WARNING:

Failure to lubricate slack adjusters could lead to dragging brakes or a brake failure, resulting in property damage, personal injury, or death.

NOTE: If equipped with an extended-maintenance Q Plus™ brake system, the slack adjuster will not have a grease fitting. These slack adjusters use a special NLGI Grade synthetic polyurea grease and do not require lubrication for 3 years or 500,000 miles (800 000 km), whichever comes first. The extended-maintenance slack adjusters are lubricated during the brake reline service interval. For service and lubrication instructions, see [General Information](#) in the *108SD Plus and 114SD Plus Workshop Manual*.

For slack adjusters with grease fittings and for operating temperatures above -40°F (-40°C), use an NLGI Grade 1 clay-base grease, or an NLGI Grade 1 or 2 lithium-base grease.

For slack adjusters with grease fittings and for operating temperatures below -40°F (-40°C) and above -65°F (-54°C), use an NLGI Grade 2 synthetic oil, clay-base grease.

Lubricate the slack adjuster at the grease fitting until grease is forced past the pressure-relief capscrew or past the gear splines around the inboard snap ring. See Fig.77, [Meritor Automatic Slack Adjuster](#).

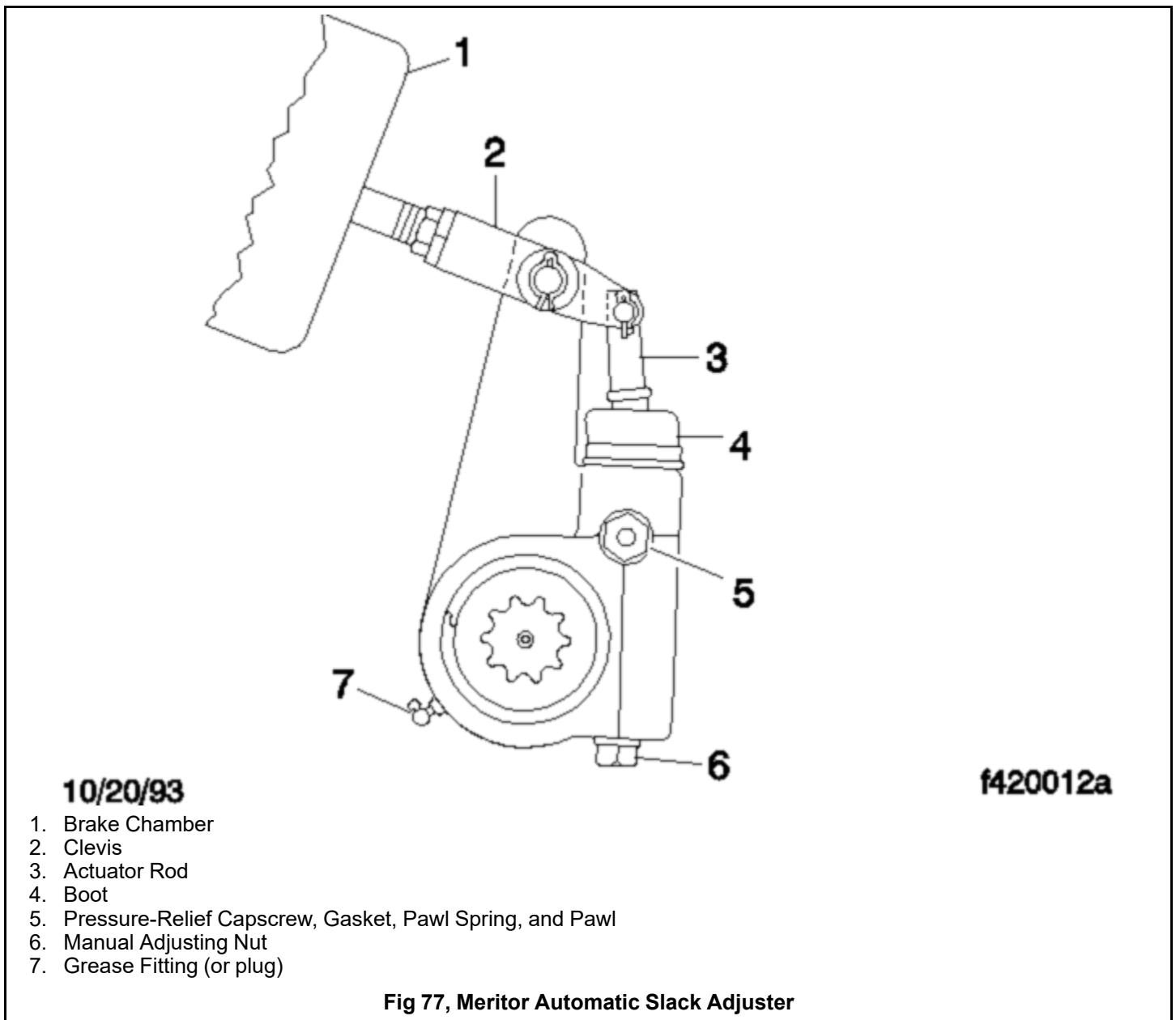

16.09 Air Dryer AD-9, AD-IP, and AD-IS/DRM Check

16.09.01 Air Dryer AD-9, AD-IP, AD-IS/DRM Check Procedure

IMPORTANT: Review the warranty policy before performing any intrusive maintenance procedures. An extended-warranty may be voided if intrusive maintenance is performed during this period.

Because no two vehicles operate under identical conditions, maintenance and maintenance intervals will vary. Experience is a valuable guide in determining the best maintenance interval for any one particular operation.

Every 900 operating hours, or 25,000 miles (40 225 km), or 3 months:

NOTE: A small amount of oil in the system is normal and should not be considered as a reason to replace the desiccant cartridge. Some oil at the dryer exhaust is normal.

1. Check for moisture in the air brake system by opening reservoir drain valves and checking for the presence of water. If moisture is present, the desiccant cartridge may require replacement; however, the following conditions can also cause water accumulation and should be considered before replacing the desiccant:
 - 1.a An outside air source has been used to charge the system. This air did not pass through the drying bed.
 - 1.b Air usage is exceptionally high and not normal. This may be due to high air system leakage.
 - 1.c In areas where more than a 30-degree range of temperature occurs in one day, small amounts of water can temporarily accumulate in the air brake system due to condensation. Under these conditions, the presence of small amounts of moisture is normal.
2. Visually check for physical damage such as chaffed or broken air and electrical lines and broken or missing parts.
3. Check mounting bolts for tightness. Torque 30 to 35 lbf·ft (41 to 47 N·m).
4. Perform the operational and leakage tests listed below.

16.09.02 Operational and Leakage Tests

1. Check all lines and fittings leading to and from the air dryer for leakage and integrity. Repair any leaks found.
2. Build system pressure to governor cutout, and note that the dryer purges with an audible escape of air. Watch the system pressure and note the pressure fall-off for a 10-minute period. If the pressure drop exceeds 1 psi/minute from either service reservoir for a single vehicle; or 3 psi/minute for a tractor trailer, inspect the vehicle air systems for sources of leakage, and repair them. Refer to troubleshooting information in Bendix service literature.
3. Check for excessive leakage around the purge valve with the compressor in the loaded mode (compressing air). Apply a soap solution to the purge valve exhaust port and observe that leakage does not exceed a 1-inch (25-mm) bubble in 1 second. If the leakage exceeds the maximum specified, refer to troubleshooting information in the Bendix service literature.
4. Build system pressure to governor cutout, and note that the dryer purges with an audible escape of air. Fan the service brakes to reduce system air pressure to governor cut-in. Note that the system once again builds to full pressure and is followed by a dryer purge. If the system does not follow this pattern, refer to troubleshooting information in the Bendix service literature.

NOTE: Some models of the AD-9 may have a resistance reading of 1.0 to 2.5 ohms.

5. Check operation of the end cover heater and thermostat assembly during cold weather, as follows:
 - 5.a **Electric Power to the Dryer:** With the ignition or engine kill switch in the ON position, check for voltage to the heater and thermostat assembly using a voltmeter or testlight. Unplug the electrical connector at the air dryer and place the test leads on each of the connections of the female connector on the vehicle power lead. If there is no voltage, look for a blown fuse, broken wires, or corrosion in the vehicle wiring harness. Check to see if a good ground path exists.

- 5.b Thermostat and Heater Assembly Operation: These tests are not possible except in cold-weather operation. Turn off the ignition switch, and cool the thermostat and heater assembly to below 40°F (4°C). Using an ohm-meter, check resistance between the electrical pins in the air dryer connector half. Resistance should be 1.5 to 3.0 ohms for the 12-volt heater assembly, and 6.0 to 9.0 ohms for the 24-volt heater assembly.

Warm the thermostat and heater assembly to approximately 90°F (32°C) and again check the resistance. Resistance should exceed 1000 ohms. If resistance values obtained are within stated limits, the thermostat and heater assembly is operating properly. If resistance values obtained are outside stated limits, replace the heater and thermostat assembly.

**WARNING:**

Do not attempt to adjust or service the pressure protection valves. Incorrect pressure protection valve settings can result in automatic application of the vehicle spring brakes without prior warning. This can cause personal injury or property damage.

6. On the AD-IS/dryer reservoir module (DRM) only, observe the pressure gauges of the vehicle as system pressure builds from zero. The primary gauge should rise until it reaches approximately 109±5 psi (751±34 kPa), then level off (or a momentary slight fall) as the second pressure protection valve opens supplying the secondary reservoir. When the secondary pressure gauge passes through approximately 55±5 psi (379±34 kPa) and then 85±5 psi (586±34 kPa) there should be an associated levelling off (or momentary slight fall) of pressure as the third and fourth pressure protection valves open. Finally, both the primary and secondary gauges should reach their full pressure of approximately 130±5 psi (896±34 kPa). If the AD-IS does not perform within the pressure ranges described above, recheck using gauges known to be accurate. If readings remain outside the ranges outlined above, replace the AD-IS.

There are no kits available for servicing the pressure protection valves.

16.10 Bendix E-6 Foot Control Valve Inspection and Lubrication

1. Remove the brake valve from the vehicle; see [General Information](#) in the *108SD Plus and 114SD Plus Workshop Manual*.
2. Remove the roll pin from the brake pedal pivot pin. See Fig. 78, [Brake Pedal and Valve Assembly](#).

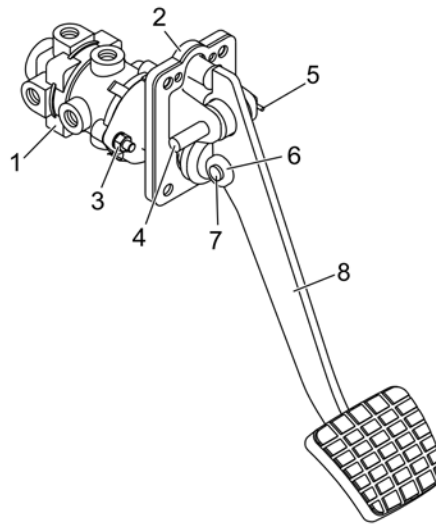

- | | |
|---------------------------|---------------|
| 1. E-6 Foot Control Valve | 5. Roll Pin |
| 2. Mounting Plate | 6. Roller |
| 3. Nut and Washer | 7. Roller Pin |
| 4. Pivot Pin | 8. Pedal |

Fig 78, Brake Pedal and Valve Assembly

3. Remove the brake pedal pivot pin.
4. Remove the brake pedal.
5. Check the brake pedal mounting plate adapter for signs of wear or cracks at the bosses (the area from which the pivot pin was removed). Replace it if necessary.
6. Check the brake pedal rollers for signs of wear or cracks. Replace the rollers as needed.
7. If the rollers are replaced, replace the roller pin, install a new cotter pin, bend it to 90 degrees and apply Torque Seal (OPG F900 White) to the cotter pin.
8. Remove the plunger from the valve. Using alcohol, clean the existing grease from the plunger. Check the plunger for signs of wear or cracks. Replace it if necessary.
9. Lubricate the plunger with barium grease (BW 246671).
10. Insert the plunger in the valve.
11. Install the brake pedal with the pivot pin.
12. Install a new roll pin and apply Torque Seal (OPG F900 White) to the roll pin.
13. Install the brake valve assembly; see [General Information](#) in the *108SD Plus and 114SD Plus Workshop Manual*.
14. Test the brakes before returning the vehicle to service.

16.11 Brake Inspection

16.11.01 Parking Brake Operational Check

IMPORTANT: This procedure should be performed prior to lubrication of the brake components.

**CAUTION:**

Perform the following check in a clear safe area. If the parking brakes fail to hold the vehicle, personal injury or property damage may result.

1. With the engine running, and air pressure at cut-out pressure, set the parking brake.
2. Put the vehicle in the lowest gear and gently attempt to move it forward. The vehicle should not move. If the vehicle moves, the parking brakes are not operating correctly and must be repaired before the vehicle is returned to service. See [General Information](#) in the *108SD Plus and 114SD Plus Workshop Manual* for repair procedures.

16.11.02 Brake Component Inspection

Air Disc Brakes

IMPORTANT: The following step to inspect the caliper mounting bolts should only be performed at the initial maintenance (IM) interval.

Vehicles may have both **axial and radial** mounted calipers. Follow the instructions based on the type of calipers installed on the vehicle.

Axial Mounted Brakes

IMPORTANT: The following information applies to all types of axial mounted brake applications.

1. Park the vehicle on a level surface, shut down the engine, and set the parking brake. Chock the tires.
2. Raise the vehicle and support it on jack stands.
3. Remove all of the wheel assemblies. For instructions, see [General Description, Wheels and Tires](#) in the *108SD Plus and 114SD Plus Workshop Manual* for repair procedures.

NOTE: In all steps that require a torque wrench, use a Snap On torque wrench ATECH4RS600, or an equivalent, with a center to handle length of 47 inches (119 cm).

4. Set a torque wrench to 350 lbf·ft (475 N·m) and tighten the caliper mounting bolts following the tightening pattern shown in Fig. 79, [Axial Bolt Tightening Pattern](#). If they do not turn, no further work is needed. If they turn, take the vehicle to an authorized Freightliner dealer to have all of the caliper bolts on that wheel end replaced. Due to limited caliper bolt access, it may be necessary to use tool DDC DSNCHA018005 referenced in tool letter 18TL18. If the tool is needed, use tool DDC DSNCHA018005 only and no other tools. See Fig. 80, [DDC DSNCHA018005 30mm Air Disc Brake Caliper Brake Bolt Torque Adaptor](#). If the tool is needed, see Table 36, [Torque Check with 47 Inch \(119 cm\) Torque Wrench and Tool DDC DSNCHA018005](#) for torque specifications for a 47 in (119 cm) long wrench.



Fig 79, Axial Bolt Tightening Pattern



09/28/2018

f580518

Fig 80, DDC DSNCHA018005 30mm Air Disc Brake Caliper Brake Bolt Torque Adaptor

Angle View	Extension Angle (degrees)	Target Torque ~*~lbf·ft (N·m)]	Tool Setting ~*~lbf·ft (N·m)]
<p>11/28/2016 f422613</p>	0	350 (475)	296 (401)
<p>11/28/2016 f422614</p>	45		310 (420)
<p>11/06/2018 f422668</p>	60		320 (434)
<p>11/28/2016 f422615</p>	90		350 (475)
<p>11/06/2018 f422669</p>	120		386 (523)
<p>11/28/2016 f422616</p>	135		40

Table 20, Torque Check with 47 Inch (119 cm) Torque Wrench and Tool DDC DSNCHA018005

5. Install the wheel assemblies. For instructions, see [General Description, Wheels and Tires](#) in the *108SD Plus and 114SD Plus Workshop Manual* for repair procedures.
6. Remove the jack stands and lower the vehicle.

Radial Mounted Brakes

Bendix Calipers

1. Park the vehicle on a level surface, shut down the engine, and set the parking brake. Chock the tires.
2. Raise the vehicle and support it on jack stands.
3. Remove all of the wheel assemblies. For instructions, see [General Description, Wheels and Tires](#) in the *108SD Plus and 114SD Plus Workshop Manual* for repair procedures.
4. Set a torque wrench to 200 lbf·ft (271 N·m) and tighten the caliper mounting bolts following the tightening pattern shown in Fig. 81, [Bendix Radial Mounted Caliper Tightening Pattern \(viewed from below\)](#). If they do not turn, no further work is needed. If they turn, take the vehicle to an authorized Freightliner dealer to have all of the caliper bolts on that wheel end replaced.

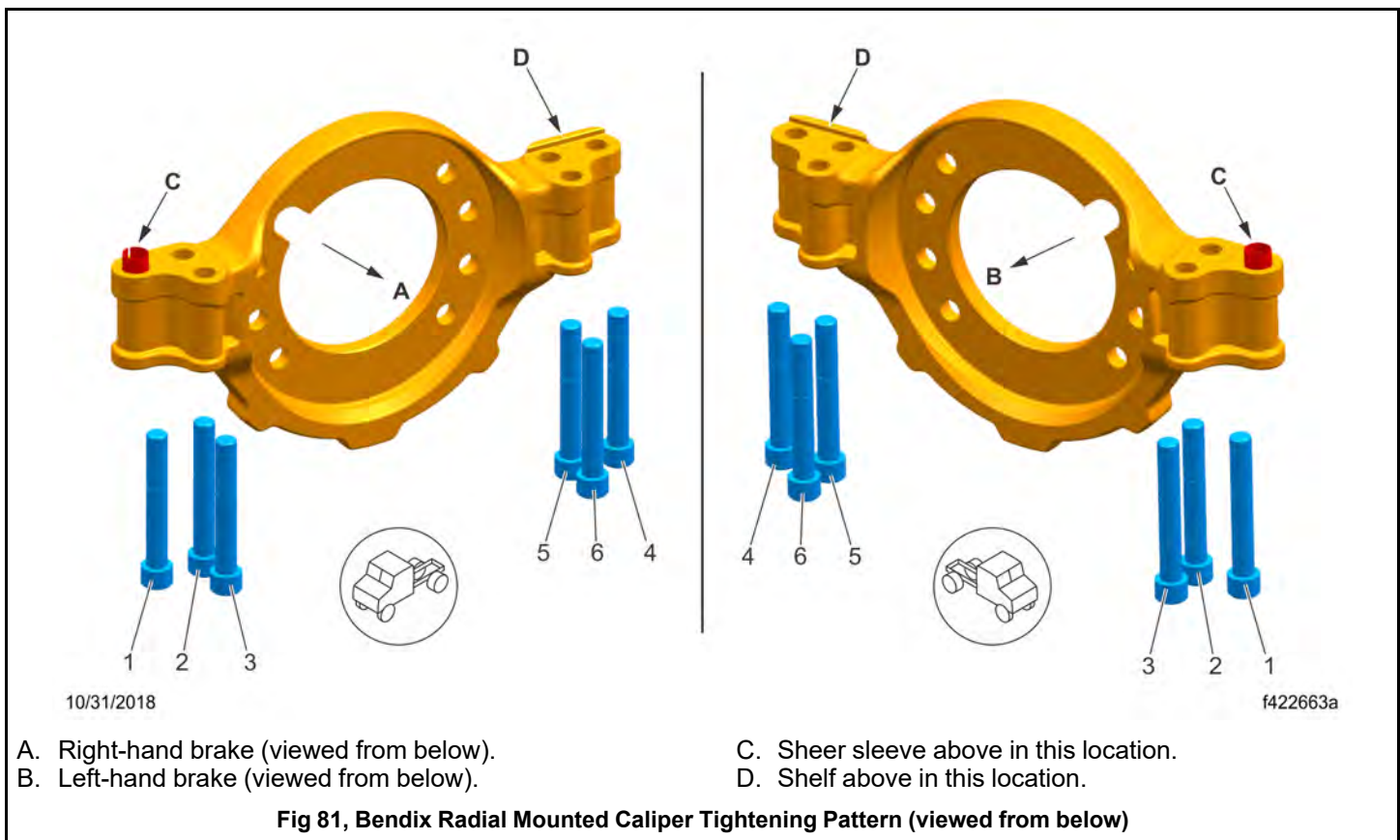

5. Install the wheel assemblies. For instructions, see [General Description, Wheels and Tires](#) in the *108SD Plus and 114SD Plus Workshop Manual* for repair procedures.
6. Remove the jack stands and lower the vehicle.

Meritor Calipers

1. Park the vehicle on a level surface, shut down the engine, and set the parking brake. Chock the tires.
2. Raise the vehicle and support it on jack stands.

3. Remove all of the wheel assemblies. For instructions, see [General Description, Wheels and Tires](#) in the *108SD Plus and 114SD Plus Workshop Manual* for repair procedures.
4. Set a torque wrench to 350 lbf·ft (475 N·m) and tighten the caliper mounting bolts following the tightening pattern shown in Fig. 82, [Meritor Radial Mounted Caliper Tightening Pattern](#). If they do not turn, no further work is needed. If they turn, take the vehicle to an authorized Freightliner dealer to have all of the caliper bolts on that wheel end replaced.

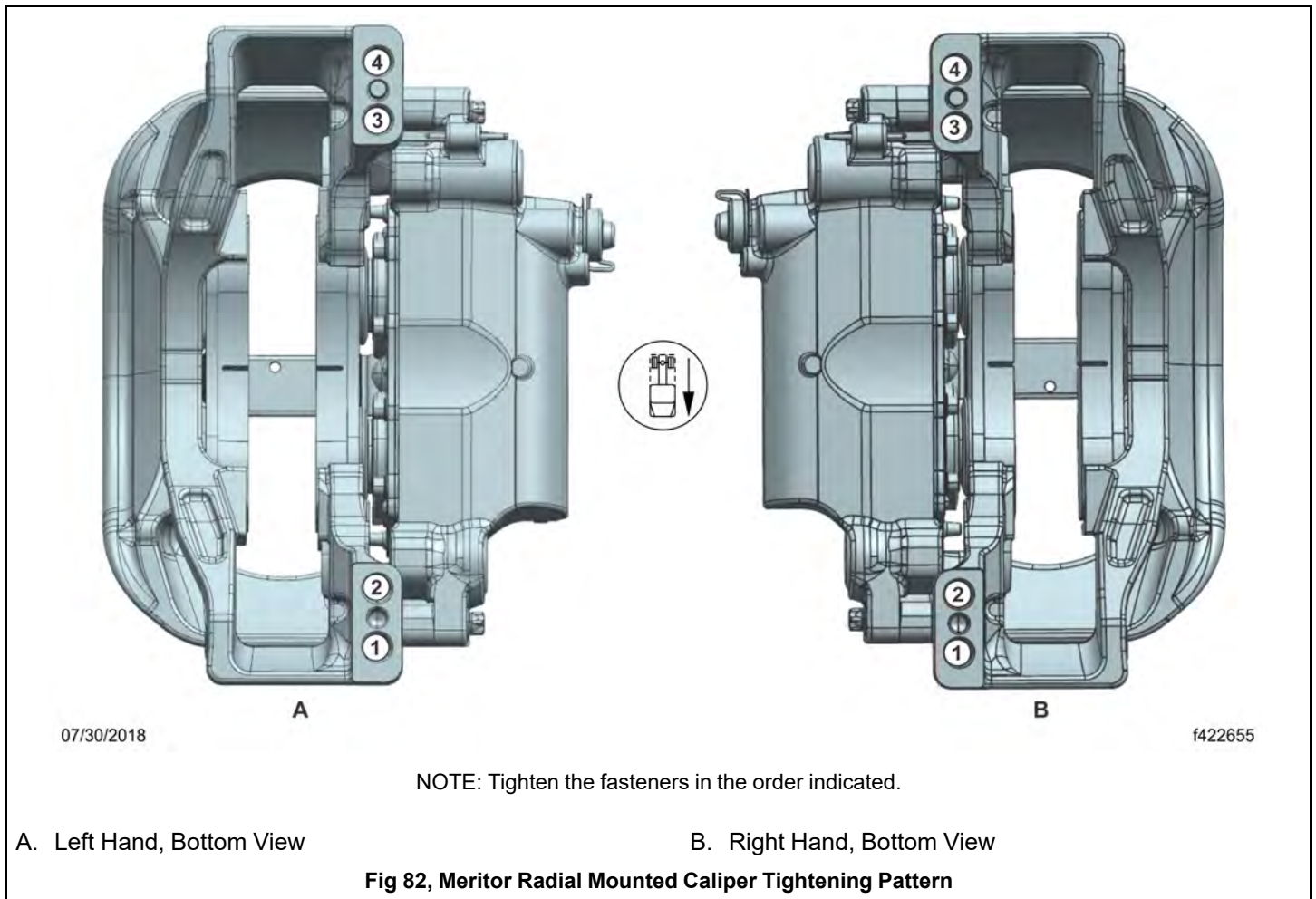

5. Install the wheel assemblies. For instructions, see [General Description, Wheels and Tires](#) in the *108SD Plus and 114SD Plus Workshop Manual* for repair procedures.
6. Remove the jack stands and lower the vehicle.

WABCO Maxxus Calipers

1. Park the vehicle on a level surface, shut down the engine, and set the parking brake. Chock the tires.
2. Raise the vehicle and support it on jack stands.
3. Remove all of the wheel assemblies. For instructions, see [General Description, Wheels and Tires](#) in the *108SD Plus and 114SD Plus Workshop Manual* for repair procedures.
4. Set a torque wrench to 273 lbf·ft (370 N·m) and tighten the caliper mounting bolts following the tightening pattern shown in Fig. 83, [Wabco Maxxus Radial Mounted Caliper Tightening Pattern](#). If they do not turn, no further work is needed. If they turn, take the vehicle to an authorized Freightliner dealer to have all of the caliper bolts on that wheel end replaced.

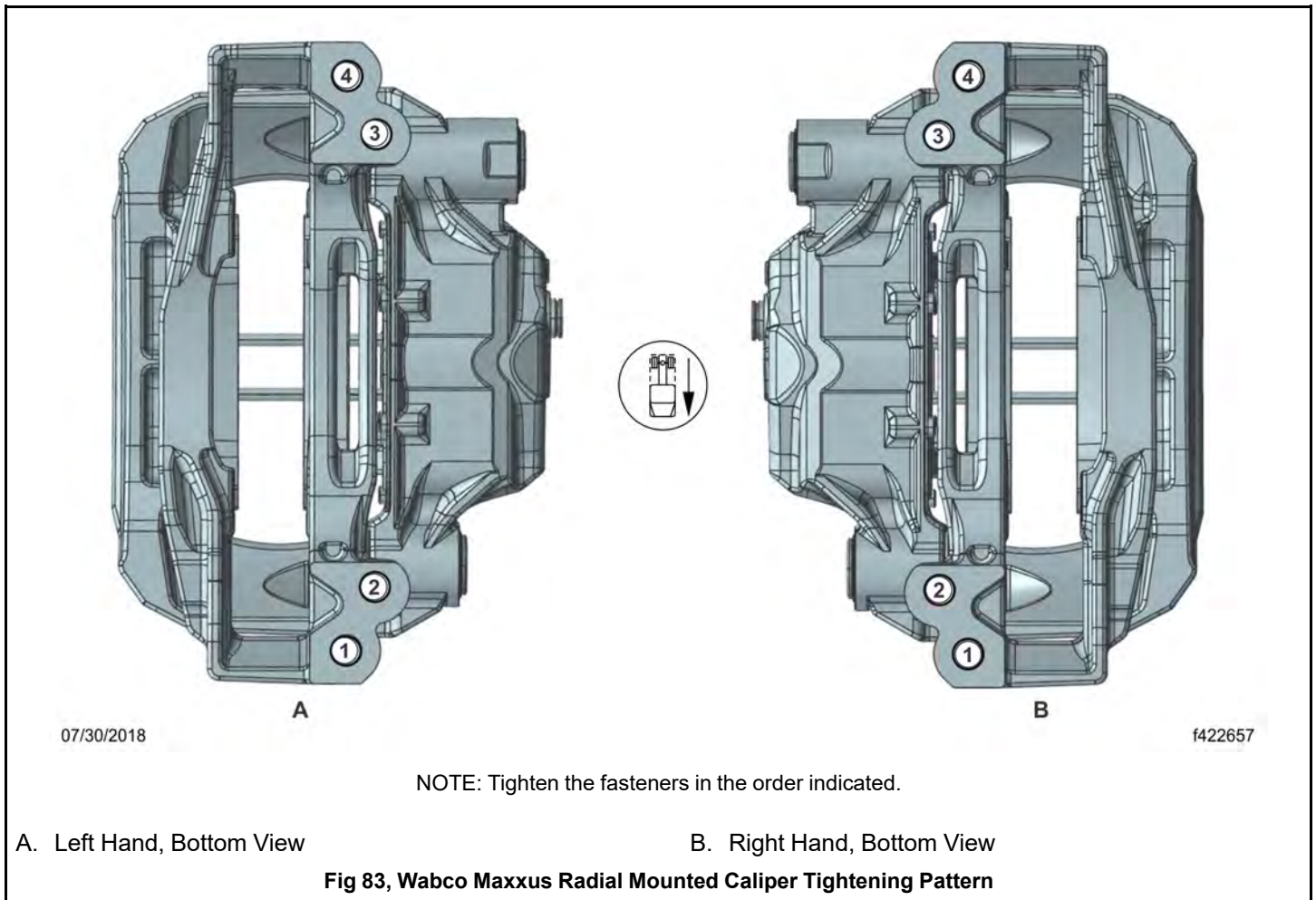

5. Install the wheel assemblies. For instructions, see [General Description, Wheels and Tires](#) in the *108SD Plus and 114SD Plus Workshop Manual* for repair procedures.
6. Remove the jack stands and lower the vehicle.

Drum Brakes

1. Park the vehicle on a level surface, shut down the engine, and set the parking brake. Chock the tires. Once the tires are chocked, release the parking brake.



WARNING:

Manually adjusting an automatic slack adjuster to bring the pushrod stroke within legal limits is likely masking a mechanical problem. Adjustment is not repairing. Before adjusting an automatic slack adjuster, troubleshoot the foundation brake system and inspect it for worn or damaged components. Improperly maintaining the vehicle braking system may lead to brake failure, resulting in property damage, personal injury, or death.

2. With the engine off, and 100 psi (690 kPa) of air tank pressure, have an assistant apply and hold an 80 to 90 psi (552 to 621 kPa) brake application.
3. Check to see if the colored over-stroke band on each brake chamber pushrod is exposed.

If a band shows, the stroke is too long. Check the foundation brake components for wear or damage, and repair as needed. See [General Information](#) in the *108SD Plus and 114SD Plus Workshop Manual* for inspection, troubleshooting, and repair procedures.

4. Measure the applied chamber stroke. See Table 37, [Brake Chamber Stroke Specifications](#) for the proper stroke for the type of chamber being used. If the stroke is too short, the brakes may drag or will not fully apply. Check for improper operation or adjustment of the automatic slack adjuster. See [General Information](#) in the *108SD Plus and 114SD Plus Workshop Manual* for inspection and troubleshooting procedures.
5. Check all of the foundation brake components for damage, wear, and loose or missing parts. Repair as needed. See [General Information](#) in the *108SD Plus and 114SD Plus Workshop Manual* for repair procedures.

Chamber			Max Applied Stroke: inch (mm)
Manufacturer	Type*	Size†	
Gunité	Standard Stroke	9	1-3/8 (35)
		12	
		16	1-3/4 (45)
		20	
		24	
		30	
	36 ¹	2 (51)	
	Long Stroke	16	2 (51)
		20	
		24	
24		2-1/2 (64)	
30			
Haldex	Standard Stroke	12	1-3/8 (35)
		16	1-3/4 (44)
		20	
		24	
	2-1/2-Inch Extended Stroke	24	2 (51)
	3-Inch Extended Stroke	24	2-1/2 (64)
	Standard Stroke	30	2 (51)
	Long Stroke	30	2-1/2 (64)

Table 37, Brake Chamber Stroke Specifications

Meritor	Standard Stroke	9	Less than 1-1/2 (38)
		12	
		16	Less than 1-3/4 (44)
		20	
	24	Less than 1-7/8 (48)	
	Long Stroke	24	Less than 2 (51)
	Standard Stroke	30	

1. If type 36 chamber is used, slack length should be less than 6 inches.

Table 21, Brake Chamber Stroke Specifications

16.12 Hydro-Max™ Brake System Inspection

NOTE: The following instructions apply to Bendix and Bosch Hydro-Max systems.

1. Check the fluid level in the hydraulic brake fluid reservoir. If needed, fill the reservoir up to the bottom of the fill-neck. See Fig. 84, [Hydraulic Brake Fluid Reservoir \(Bosch reservoir shown, Bendix reservoir similar\)](#). Use only heavy-duty brake fluid, DOT 3.

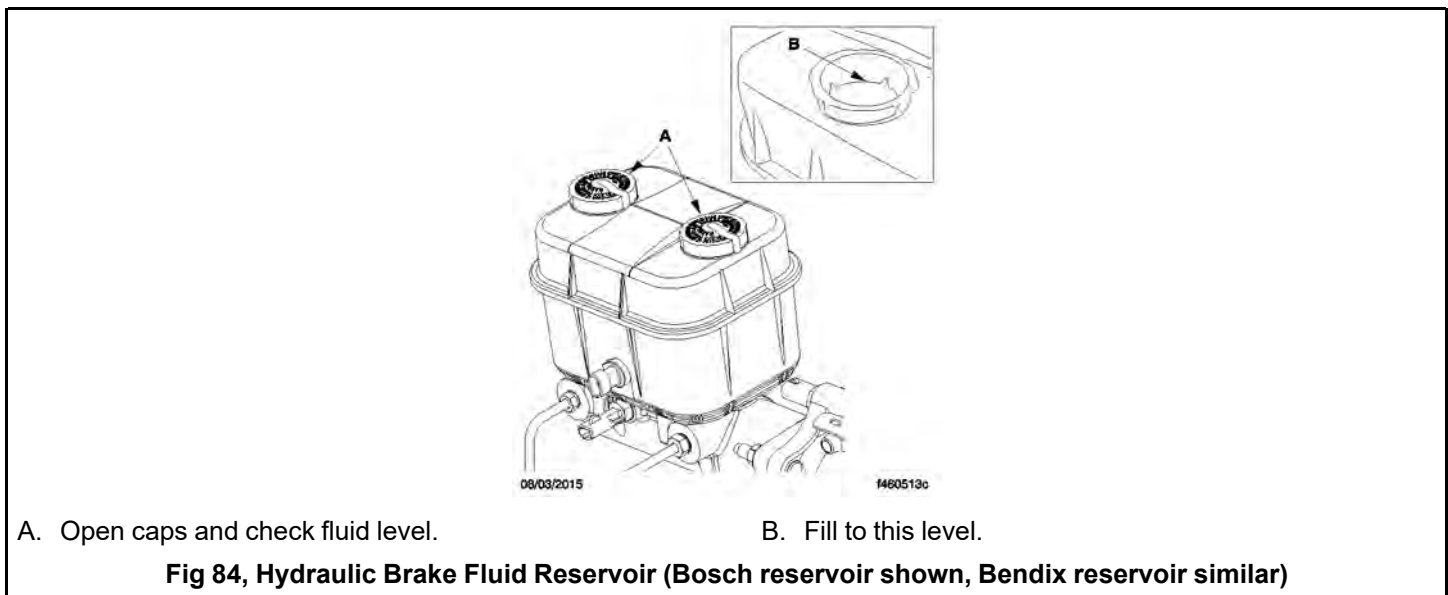

2. Check all hydraulic lines and fittings for damage, leakage, or looseness.
Replace damaged or leaking components, and tighten loose fittings.
3. Check the brake module for leaks. If leaks are found, repair or replace the brake module. See [General Information](#) in the *108SD Plus and 114SD Plus Workshop Manual* for replacement instructions, or take the vehicle to an authorized Freightliner dealer.
4. Check the electrical connections and harnesses. Make sure the connectors are fully seated and the harnesses are not chafed or cut. Repair or replace any damaged harness. Disconnect any loose connectors and inspect the terminals for corrosion. If corrosion is present, replace the terminals. If corrosion is not present, reconnect the connector.
5. Check the fuse for the hydraulic brake booster pump, as follows.
 - 5.a Open the cover to the main Power Distribution Module (PDM).

- 5.b Pull the fuse in position F6 for the Hydro-Max relay.
- 5.c Inspect the relay to make sure the fuse is not damaged. If the fuse is damaged, install a new fuse. If the fuse is not damaged, install the fuse in position F6.
- 5.d Close the PDM cover.
6. Check the operation of the Hydro-Max brake booster, as follows.
 - 6.a With the engine off, depress the brake pedal; the warning light and buzzer should come on, and the electric motor should run.
 - 6.b Start the engine and allow the gauges to sweep. Depress the brake pedal; no warning lights, buzzer, or electric motor should come on.

16.13 Replacement of the WABCO System Saver Air Dryer Desiccant Cartridge

NOTE: The following instructions apply to the System Saver 1200, 1200 Plus, and Twin air dryers.



NOTICE:

The WABCO System Saver air dryers can use either a standard or oil coalescing desiccant cartridge. When replacing the desiccant cartridge, it is very important to use the same type of cartridge that was originally installed on the dryer. Oil coalescing cartridges can be used in any application, but require more frequent service intervals. **Do not** replace an oil coalescing cartridge with a standard cartridge, as this may result in contamination and malfunctioning of downstream air system components.

See Fig. 85, [Desiccant Cartridge Replacement](#) for cartridge replacement.

1. Drain the air system.

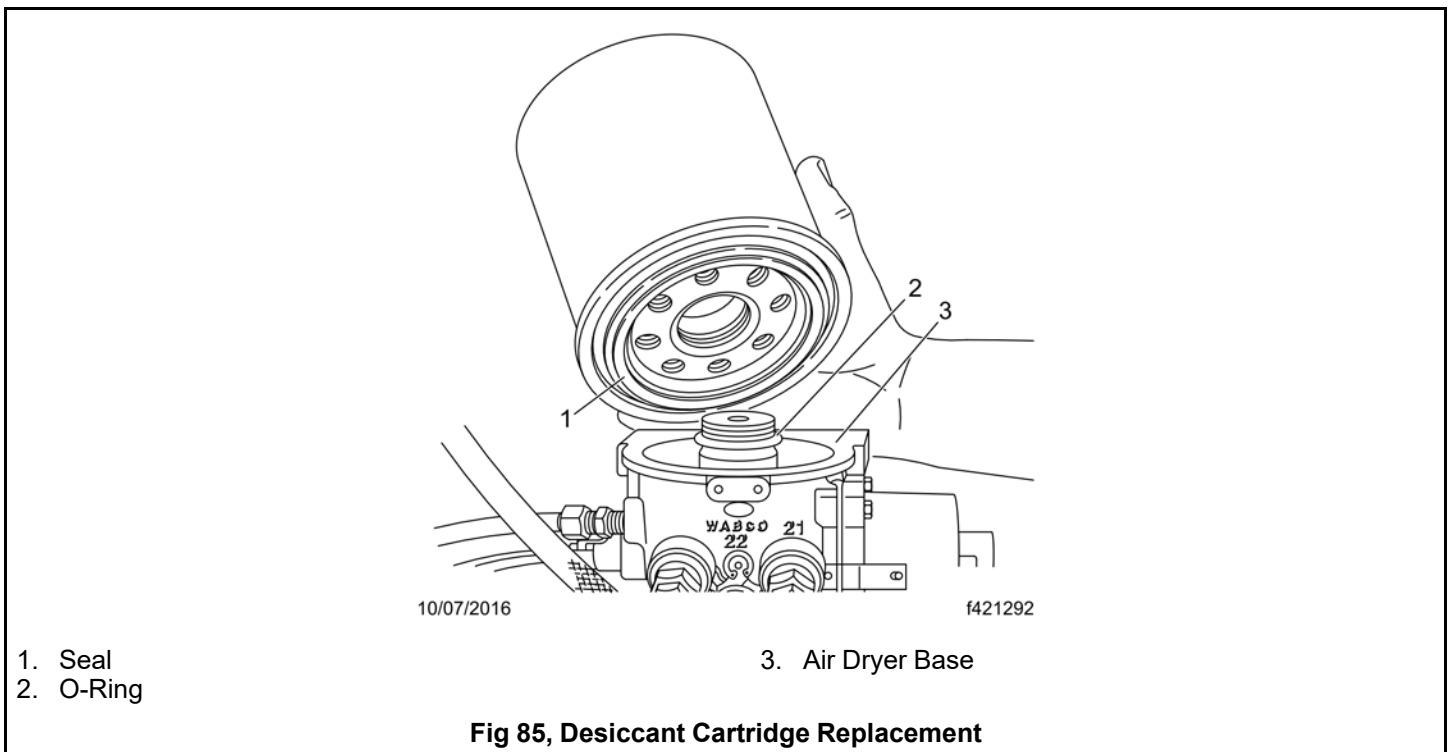

2. Using a strap wrench, turn the desiccant cartridge counterclockwise and remove it.
3. Remove and discard the O-ring.
4. Clean the top surface of the dryer base with a commercial cleaning solvent.

IMPORTANT: If the air dryer base is damaged, preventing a tight seal, replace the air dryer.

5. Using a multipurpose, high-temperature grease that resists water, steam, and alkali, lightly coat the surfaces of the new O-ring and the dryer base. Install the O-ring.
6. Thread the desiccant cartridge onto the dryer base (turn clockwise). When the seal contacts the base, tighten the cartridge one complete turn more. Do not overtighten.

16.14 Versajust Slack Adjuster Inspection and Lubrication

16.14.01 Inspection Procedure

IMPORTANT: Perform the Brake Inspection maintenance operations before lubricating the slack adjusters.

1. Visually check for physical damage, such as broken air lines and broken or missing parts.
2. Using a quality multipurpose chassis lubricant, NLGI Grade 2, lubricate the slack adjuster through the grease fitting until clean lubricant flows from the grease relief opening in the boot.
3. Perform the [16.14.02 In Service Inspection](#) .

16.14.02 In Service Inspection

1. Apply and release the brakes several times while observing the slack adjuster. The slack adjuster and brake actuator should move freely, without binding or interference, and should return to the full released position. Observe the looseness that exists between the clevis and adapter bushing and the yoke and link pins and their mating parts (clevis, body, link). Replace these parts if looseness appears excessive. Make certain the brake actuator pushrod jam nut is tightened securely.
2. Inspect the slack adjuster for physical damage, paying attention to the link, boot, and clevis. If any components are damaged, repair or replace them as necessary.
3. Measure the brake actuator pushrod stroke while making an 80 to 90 psi (552 to 621 kPa) brake application. Actuator pushrod strokes should not exceed the values shown in Tables 38, [Actuator Stroke–Standard Stroke](#) and 39, [Actuator Stroke–Long Stroke](#). To achieve the correct pressure for this test, build the system pressure up to a 100 psi (690 kPa). Shut down the engine. Fan the brakes to attain a 90 to 95 psi (621 to 655 kPa) reading. Make and hold a full brake application while the strokes are checked.

Brake Actuator Size	Recommended Maximum Operating Stroke (Inches)
30	2
24	1-3/4
20	1-3/4
16	1-3/4
12	1-3/8

Table 22, Actuator Stroke–Standard Stroke

Brake Actuator Size	Recommended Maximum Operating Stroke (Inches)
30 Long Stroke	2-1/2
24 Long	2
24 Long Stroke	2-1/2
20 Long	2
16 Long	2

Table 23, Actuator Stroke–Long Stroke

17.01 Safety Precautions	160
17.02 Drag Link Inspection	160
17.03 Power Steering Fluid Changing	160
17.04 Power Steering Gear Lubrication	162
17.05 Power Steering Filter Changing	162

17. Steering

17.01 Safety Precautions

Safety Precautions in this section apply to all procedures within this group.

**DANGER:**

When working on the vehicle, shut down the engine or motor, set the parking brake, and chock the tires. Before working under the vehicle, always place jack stands under the frame rails to ensure the vehicle cannot drop. Failure to follow these steps could result in serious personal injury or death.

17.02 Drag Link Inspection

**WARNING:**

All steering system components are critical for safe operation of the vehicle. Failure to maintain the steering system as specified may result in loss of steering control, which could lead to personal injury and property damage.

Have someone turn the steering wheel from left to right. Check for movement between the ball stud end at both the pitman arm and the steering arm. Also check if the ball stud nut is loose.

If the ball stud end is loose, replace the drag link. If the ball stud nut is loose, replace the nut and cotter key. See [General Information, Power Steering System](#) in the *108SD and 114SD Plus Workshop Manual* for drag link removal and installation instructions.

Inspect the boot of the drag link at both the pitman arm and the steering arm end for cracks, splits, or other damage. Replace the boot as needed.

Grasp the drag link near the pitman arm end, then push and pull laterally to check for axial movement in the ball stud end. If it is loose, replace the drag link. If there is 1/8-inch (3-mm) movement or more, do not drive the vehicle until the drag link is replaced.

17.03 Power Steering Fluid Changing

**WARNING:**

Fill only with approved clean fluid. Failure to use the proper fluid could cause seal deterioration and leaks. Fluid leaks could eventually cause loss of power steering assist. This could lead to an accident resulting in personal injury or property damage. Wear eye protection when changing the fluid and filter.

1. Apply the parking brakes and chock the rear tires.
2. Place a drain pan under the power steering reservoir.
3. Remove the retaining ring from the reservoir. See Fig. 86, [Power Steering Reservoir](#).

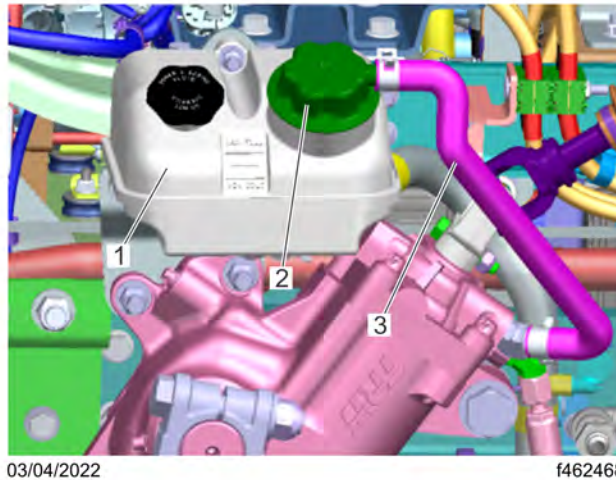

1. Power Steering Reservoir
 2. Filter Cover
 3. Return Hose

Fig 86, Power Steering Reservoir

4. Remove the filter and filter cover from the reservoir. Drain the fluid from the filter into the drain pan. Leave the filter hanging over the drain pan.
5. Remove the bolts, nuts, and washers that attach the power steering reservoir to the mounting bracket. Drain the power steering fluid from the reservoir, but do not remove the supply line to the reservoir.
6. Using bolts, nuts, and washers, attach the reservoir to the mounting bracket.
7. Fill the reservoir with an approved power steering fluid to the line between the MIN COLD and MAX HOT lines. See Fig. 86, [Power Steering Reservoir](#). See Table 40, [Approved Power Steering Fluids](#) for approved power steering fluids.

Fluid Type ¹	Approved Fluid*
Automatic Transmission Fluid	Dexron® III
	Dexron® II

8. Raise the front of the vehicle and support it with jack stands.
9. Start the engine and operate it at idle. Turn the steering wheel from full left to full right several times until clean oil starts flowing from the power steering filter. Add fluid to the reservoir to maintain the fluid level between the MIN COLD and MAX HOT lines.
10. Shut down the engine and install the filter and filter cover in the reservoir. Make sure that the gasket under the filter cover is not damaged. If the gasket is damaged, replace it. Install the gasket on the reservoir.
11. Attach the retaining ring to the reservoir to secure the filter and filter cover.
12. Start the engine and check that the power steering fluid level is between the MIN COLD and MAX HOT lines. Add more power steering fluid if needed.
13. Raise the vehicle, remove the jack stands, and lower the vehicle.
14. Remove the chocks from the tires.

17.04 Power Steering Gear Lubrication

NOTICE:

Apply grease to the sector shaft with a hand-type grease gun only. Use of a high-pressure power grease gun will supply grease too quickly and could affect the high pressure seal, contaminating the hydraulic fluid.

Using a hand-type grease gun, apply NLGI Grade 2 or 3 multipurpose chassis grease until it starts to come out past the sector shaft seal. See Fig. 87, [Steering Gear Lubrication](#).

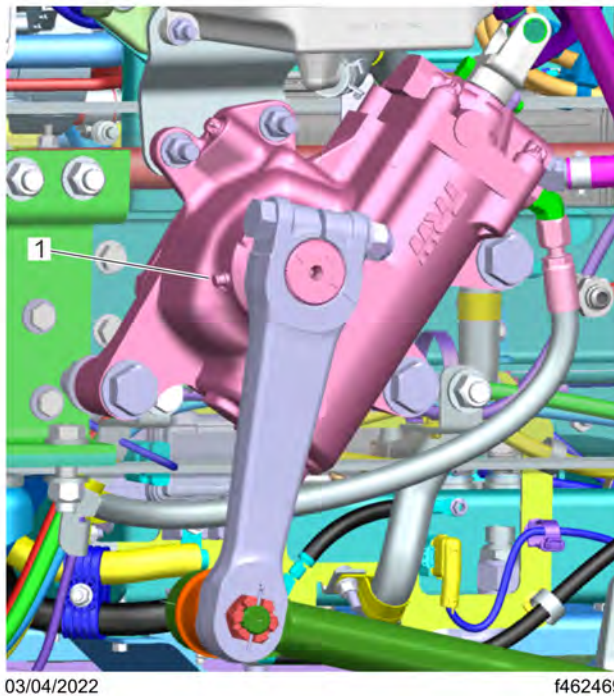

1. Sector Shaft Grease Fitting

Fig 87, Steering Gear Lubrication

17.05 Power Steering Filter Changing

1. Apply the parking brakes and chock the rear tires.
2. Raise the front of the vehicle and support it with jack stands.
3. Remove the filter, filter cover, and gasket from the reservoir.
4. Disconnect the filter from the filter cover, and discard the filter.
5. Apply a thin film of power steering fluid on the gasket of the new filter. Then attach the filter to the filter cover.
6. Check for damage to the gasket that was removed from the reservoir. If the gasket is damaged, replace it. Install the gasket on the reservoir.
7. Install the filter and filter cover in the reservoir.
8. Check the fluid level in the reservoir. If necessary, add fluid to the reservoir to maintain the fluid level between the MIN COLD and MAX HOT lines. See Table 41, [Approved Power Steering Fluids](#) for approved power steering fluids.

Fluid Type ¹	Approved Fluid*
Automatic Transmission Fluid	Dexron® III
	Dexron® II

9. Raise the vehicle and remove the jack stands, then lower the vehicle.
10. Remove the chocks from the tires.

18.01 Safety Precautions	166
18.02 Tightening the Fuel Tank Band Nut	166
18.03 Fuel/Water Separator Element Replacing.....	166
18.03.01 Alliance	166
18.03.02 DAVCO Diesel Pro® and Fuel Pro® Models.....	168
18.03.03 Detroit.....	171
18.04 LNG Fuel System Inspecting	172
18.04.01 General Information	172
18.04.02 Inspecting the Fuel Tank and Shroud.....	173
18.04.03 Inspecting the Plumbing Components.....	174
18.04.04 Inspecting the Fuel Level Sender Component	174
18.04.05 Inspecting the Vaporizer	175
18.05 LNG Vacuum Integrity Testing	176
18.06 Inspecting the CNG Fuel System.....	178
18.07 Replacement of the CNG High-Pressure Fuel Filter Element	180
18.08 Inspection of the CNG Fuel Cylinder	182

18. Fuel

18.01 Safety Precautions

Safety Precautions in this section apply to all procedures within this group.

**DANGER:**

When working on the vehicle, shut down the engine or motor, set the parking brake, and chock the tires. Before working under the vehicle, always place jack stands under the frame rails to ensure the vehicle cannot drop. Failure to follow these steps could result in serious personal injury or death.

18.02 Tightening the Fuel Tank Band Nut

IMPORTANT: Do not overtighten the nuts.

Rectangular Fuel Tank

Hold the retention nut on the fuel tank band with a wrench while backing off the jam nut. Then tighten the retention nut 13 to 17 lbf·ft (18 to 23 N·m). After the retention nut has been tightened, hold the retention nut with a wrench while tightening the jam nut 13 to 17 lbf·ft (18 to 23 N·m).

Cylindrical Fuel Tank

Hold the retention nut on the fuel tank band with a wrench while backing off the jam nut. Then tighten the retention nut 30 to 35 lbf·ft (41 to 46 N·m). After the retention nut has been tightened, hold the retention nut with a wrench while tightening the jam nut 30 to 35 lbf·ft (41 to 46 N·m).

18.03 Fuel/Water Separator Element Replacing

18.03.01 Alliance

The only maintenance necessary on an Alliance fuel/water separator is to replace the filter element.

**WARNING:**

Diesel fuel is flammable and can ignite if exposed to an open flame, intense heat, or other ignition source. Do not drain fuel near, or expose fuel vapor to open flame or intense heat. Exposure to open flame or intense heat could start a fire, possibly resulting in personal injury or property damage. When working on a fuel system, have a fire extinguisher within easy reach.

1. Drain off some fuel by loosening the vent plug and opening the drain valve. See Fig.88,[Alliance Fuel/Water Separator](#).

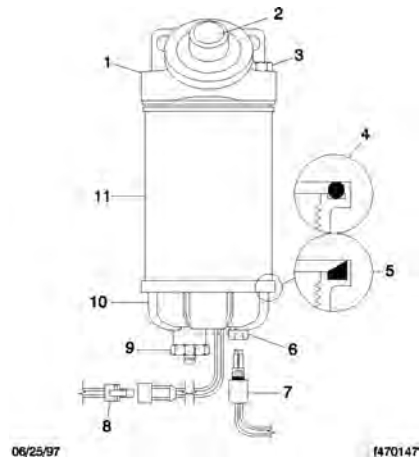

- | | |
|---------------------|-----------------------|
| 1. Mounting Head | 7. Water Sensor Probe |
| 2. Fuel Primer Pump | 8. Heater Connector |
| 3. Vent Plug | 9. Drain Plug |
| 4. Bowl O-Ring | 10. Sight Bowl |
| 5. Bowl Gasket | 11. Filter Element |
| 6. Bowl Probe Plug | |

Fig 88, Alliance Fuel/Water Separator

2. Disconnect the water sensor and heater connections if equipped.
3. Remove the element and bowl together, by turning counterclockwise.
4. Remove the bowl from the element and clean the O-ring gland.
5. Apply a coating of clean fuel or motor oil to the new O-ring and element seal.
6. Spin the bowl onto the new element, then spin them both onto the filter head, snugly, by hand only.

IMPORTANT: Do not use tools to tighten the bowl and element.

7. Connect the water sensor and heater connectors if equipped.
8. If equipped with a primer pump, prime the fuel/water separator.
 - 8.a Loosen the vent plug. Then operate the primer pump until the fuel purges at the vent plug.
 - 8.b Close the vent plug.
9. Start the engine and check for fuel leaks.
10. Shut down the engine and correct any fuel leaks.

18.03.02 DAVCO Diesel Pro® and Fuel Pro® Models

**WARNING:**

Fluid circulated through the fuel/water separator to heat the fuel may be diesel fuel returned from the engine, or engine coolant. Drain the fuel/water separator only when the engine and fluids have cooled. Draining it when the engine is hot could cause severe personal injury due to scalding.

If returning fuel is released into the atmosphere, its vapors can ignite in the presence of any ignition source. Do not expose the fuel to, or work with the fuel system near, open flame or intense heat. To do so could cause fire, possibly resulting in serious personal injury or property damage.

1. Shut down the engine, apply the parking brake, and chock the tires.
2. Check the fuel level in the fuel filter. Replace the fuel/water separator element **only** when the filter element is completely covered. If the fuel level has reached the top of the filter element, follow the procedure below to replace the element.
3. Put a clean receptacle under the fuel/water separator and attach a piece of hose to the drain valve, to direct fuel into the receptacle.
4. Remove the vent cap, shown in Fig.89,[DAVCO Fuel Pro 487](#), to drain the fuel completely, then close the drain valve.

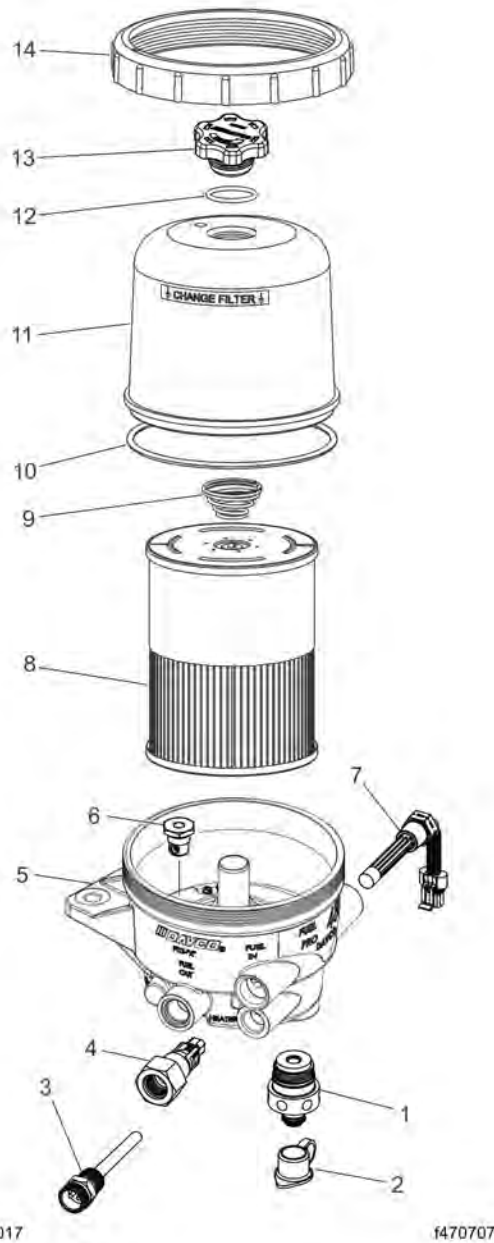

- | | |
|---------------------------|---------------------|
| 1. Drain Valve | 8. Filter Element |
| 2. Drain Valve Cap | 9. Spring |
| 3. 120VAC Pre-Heater | 10. Cover O-Ring |
| 4. Inlet Port/Check Valve | 11. Clear Cover |
| 5. Lower Housing | 12. Vent Cap O-Ring |
| 6. Bypass Valve | 13. Vent Cap |
| 7. 12VDC Pre-Heater | 14. Collar |

Fig 89, DAVCO Fuel Pro 487

5. Using a collar wrench, shown in Fig. 90, [Collar Wrench](#), remove the collar and clear cover.

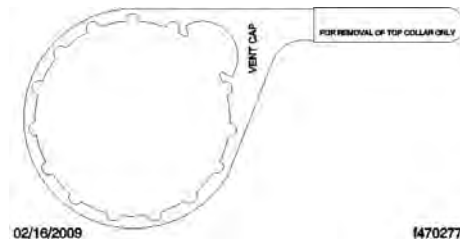

Fig 90, Collar Wrench

6. Remove the filter, cover O-ring, and vent cap O-ring. See Fig. 89, [DAVCO Fuel Pro 487](#).
7. Clean all threads and sealing surfaces very thoroughly. Even a small amount of dirt will prevent the fuel/water separator from sealing, and an air leak may result.

NOTE: Some models use a filter assembly that includes the bottom grommet.

8. Install the new filter and grommet and cover O-ring on the housing.

For filter elements that have an alignment feature, position the filter element so the key is lined up with the keyway on the separator plate of the housing. Use the arrow on the top of the endplate to align the filter. See Fig.

91, [Positioning the Filter Element](#). Ensure the filter element is fully seated by firmly pushing on the endplate. The filter should not rotate freely.

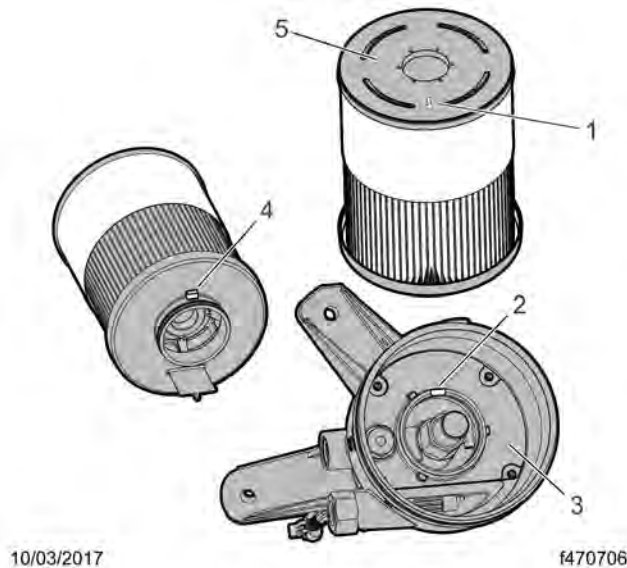

1. Arrow (on the endplate)
2. Keyway
3. Separator Plate

4. Key
5. Endplate

Fig 91, Positioning the Filter Element

9. Install the clear cover and the collar. Simultaneously apply downward pressure to the top of the clear cover until it is seated on the body of the lower housing and hand tighten the collar until it no longer spins freely. Using the collar wrench, tighten the cover 18 lbf·ft (24 N·m). This is equivalent to rotating the collar clockwise two or three additional ribs, depending on the specific filter model.

10. Prime the system
 - 10.a Ensure that the drain valve is closed.
 - 10.b Fill the housing to the top of the filter element with clean diesel fuel.
 - 10.c Install and hand-tighten the vent cap O-ring and vent cap.
 - 10.d Start the engine. When the lubricating oil reaches its normal operating pressure, increase engine speed to high idle for one to two minutes to purge air from the system.
 - 10.e While the engine is running, and after the air is purged from the system, loosen the vent cap until the fuel level falls to just above the collar, then hand-tighten the vent cap.
 - 10.f Check for leaks and shut down the engine.

18.03.03 Detroit

The only maintenance necessary on an Detroit fuel/water separator is to replace the filter element. See Fig. 92, [Detroit Fuel/Water Separator](#).

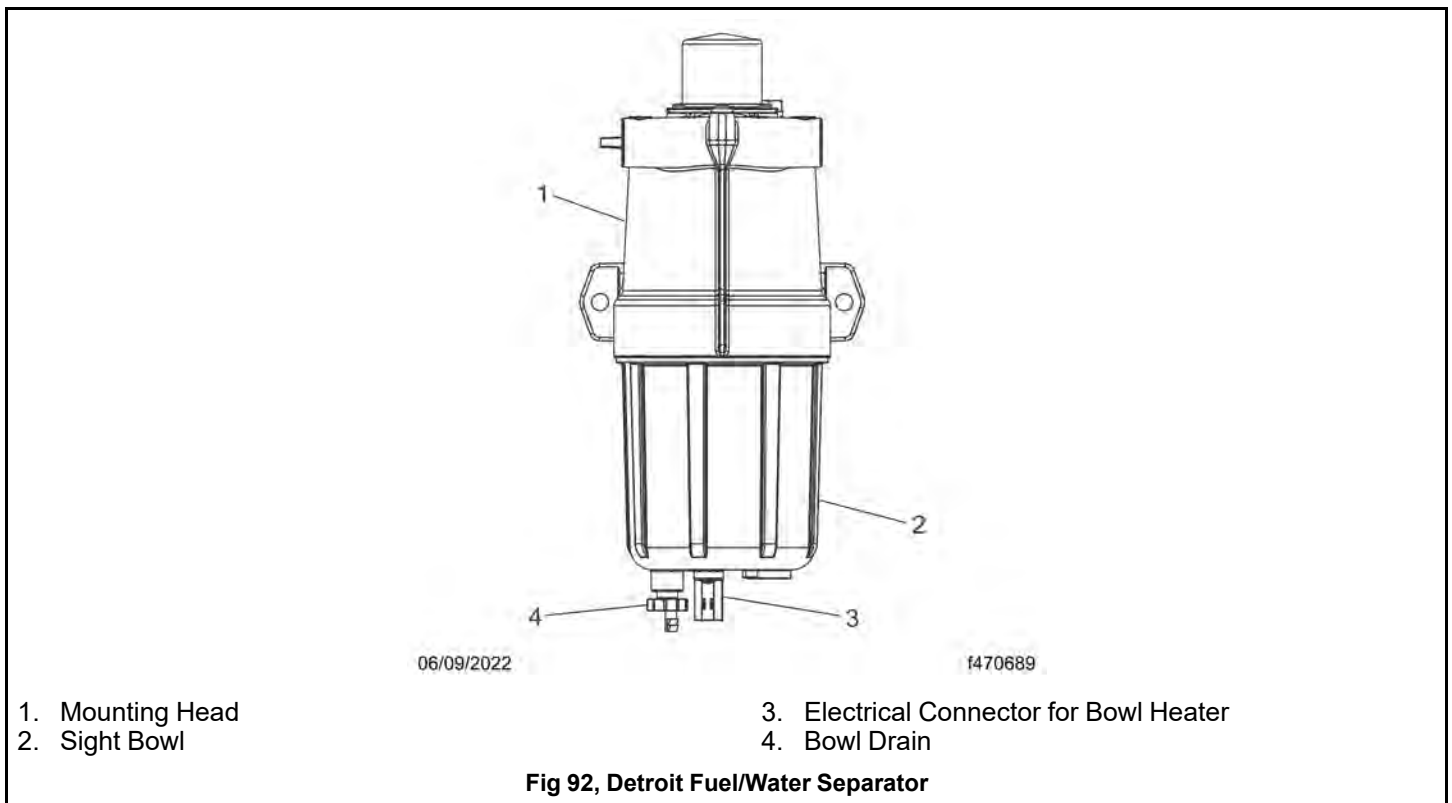

**WARNING:**

Fluid circulated through the fuel/water separator to heat the fuel may be diesel fuel returned from the engine, or engine coolant. Drain the fuel/water separator only when the engine and fluids have cooled. Draining it when the engine is hot could cause severe personal injury due to scalding.

If returning fuel is released into the atmosphere, its vapors can ignite in the presence of any ignition source. Do not expose the fuel to, or work with the fuel system near, open flame or intense heat. To do so could cause fire, possibly resulting in serious personal injury or property damage.

1. Drain off some fuel by loosening the vent plug and opening the drain valve.
2. Disconnect the water sensor and heater connections if equipped.
3. Remove the bowl by turning counterclockwise.
4. Remove the element, bowl O-ring, and element O-ring. Dispose of them in an environmentally acceptable manner.
5. Thoroughly clean all of the threads and sealing surfaces. Even a small amount of dirt will prevent the fuel/water separator from sealing, and an air leak may result.
6. Apply a coating of clean fuel or motor oil to the new O-ring and to the new element O-ring.
7. Insert the new element into the upper housing.

IMPORTANT: Do not use tools to tighten the bowl and element.

8. Spin the bowl onto the onto the upper housing by hand only.
9. Connect the water sensor and heater connectors if equipped.
10. If equipped with a primer pump, prime the fuel/water separator as follows.
 - 10.a Loosen the vent plug. Then operate the primer pump until the fuel purges at the vent plug.
 - 10.b Close the vent plug.
11. Start the engine and check for fuel leaks.
12. Shut down the engine and correct any fuel leaks.

18.04 LNG Fuel System Inspecting

18.04.01 General Information

**WARNING:**

Natural gas is highly flammable. See the safety precautions listed, see General Information, Diesel Fuel Tanks and Fuel Lines in the *108SD and 114SD Plus Workshop Manual*. Failure to observe these precautions could lead to the ignition of the natural gas, which could cause serious bodily injury or death.

The following inspections must be performed by a qualified technician, in accordance with the manufacturer's established inspection criteria.

All tank components should be allowed to defrost before conducting the following inspections.



NOTICE:

Do not use a high-pressure washer or steam cleaner on natural gas fuel system plumbing components, as this can introduce moisture and contaminants into the threads of the fittings and damage the sealants.

Gas detection sensors are located on the cab overhead console and in the engine compartment on the frontwall. The sensors are located in high areas, where rising gas vapors will pass by or accumulate. Do not use a high-pressure washer, steam cleaner, or silicone-based chemicals on the gas detection sensors, as this may permanently disable the sensors. When cleaning the vehicle, cover the sensors with a plastic covering. Keep the sensors covered until the area has been cleared of any cleaning fumes. Harsh chemicals and extremely high temperatures may damage the sensor.

18.04.02 Inspecting the Fuel Tank and Shroud

See Fig. 93, [Fuel Tank Outer Shell](#) for fuel tank and shroud component locations.

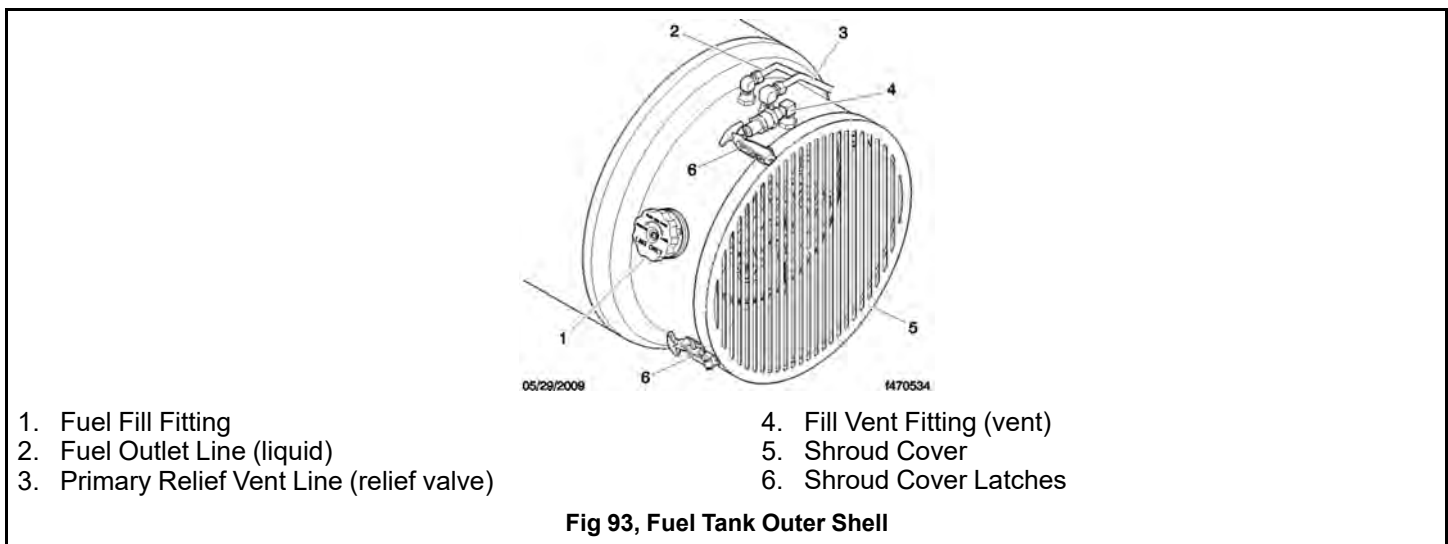

1. Inspect the fuel tank outer shell for dents or other signs of damage. Inspect the bottom of the tank for deep scratches, flat spots, or gouges.
Replace a leaking fuel tank.
2. Ensure that the fuel tank is secured to its mounting brackets and that the mounting brackets are secured to the frame. Inspect for any signs of looseness.
3. Ensure that all rubber isolator straps are present and secure.
4. Look for signs of abrasion between the fuel tank and mounting brackets.
5. Inspect the fuel fill fitting for signs of damage or leaks. Ensure the fuel fill cap is present and in good condition, and the fitting is mounted securely on the tank.
6. Inspect the fuel outlet line and fitting for signs of leaks or damage.
7. Inspect the primary relief vent and pipe-away line for damage, kinks, chafing, or loose connections.
8. Inspect the fill vent fitting for signs of damage.
9. Inspect the shroud cover for dents or other signs of damage. Ensure that the shroud cover latches are in working condition and fasten the shroud cover securely to the tank.
10. Replace leaking or damaged fuel lines. Repair or replace leaking or damaged fittings.

18.04.03 Inspecting the Plumbing Components

See Fig. 94, [Fuel Tank Plumbing Components](#) for plumbing component locations.

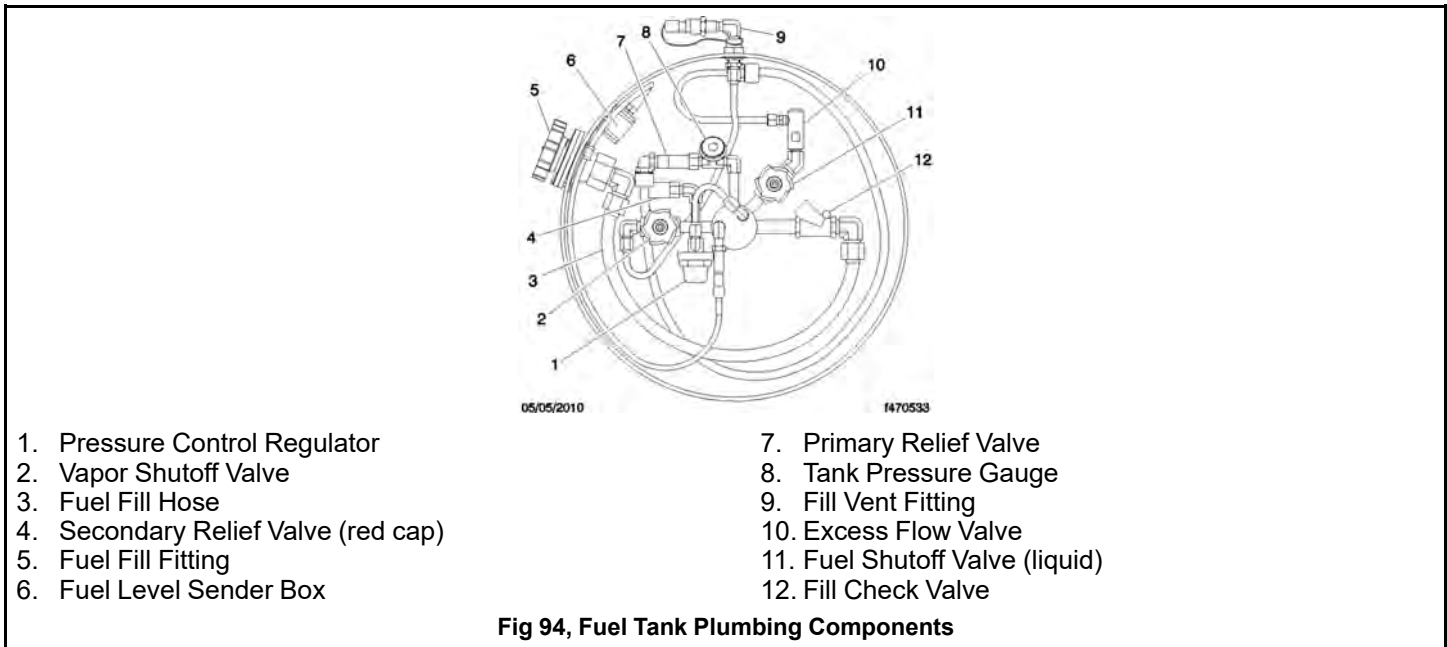

Use a bubble solution to check for leaks while performing the following visual inspection.

1. Check the following components for signs of damage or leaks:
 - pressure control regulator
 - vapor shutoff valve
 - secondary relief valve
 - primary relief valve and threaded connections
 - excess flow valve
 - fuel shutoff valve
 - fill check valve
2. Inspect the fuel fill line for signs of damage, kinked or crushed piping, or chafing.
3. Ensure the red cap is present on the secondary relief valve.
4. Inspect the fuel tank pressure gauge for cracks in the sight glass. Ensure the indicator needle is present and in working condition. Inspect the gauge face for accuracy and legibility.
5. Inspect all vent lines for kinks, and signs of leaks or damage.
6. Replace leaking or damaged fuel lines. Repair or replace leaking or damaged fittings.

18.04.04 Inspecting the Fuel Level Sender Component

1. Inspect the fuel level sender wiring harness for signs of loose connections or damage. Look for cracking or signs of moisture intrusion.
2. Inspect the fuel level sender box (Fig. 95, [Fuel Tank Plumbing Components](#), Item 6) for signs of leaks or damage. Ensure that the retainer clips are installed on the mounting ears.

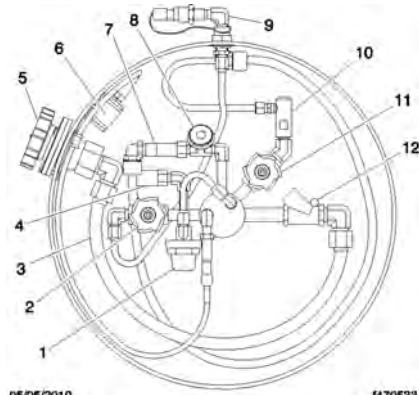

05/05/2010

1470533

- | | |
|-------------------------------------|---------------------------------|
| 1. Pressure Control Regulator | 7. Primary Relief Valve |
| 2. Vapor Shutoff Valve | 8. Tank Pressure Gauge |
| 3. Fuel Fill Hose | 9. Fill Vent Fitting |
| 4. Secondary Relief Valve (red cap) | 10. Excess Flow Valve |
| 5. Fuel Fill Fitting | 11. Fuel Shutoff Valve (liquid) |
| 6. Fuel Level Sender Box | 12. Fill Check Valve |

Fig 95, Fuel Tank Plumbing Components

3. Inspect all connectors and wiring for signs of loose connections, damage, or chafing.
4. Turn the ignition switch to the ON position and check for fuel gauge response.
5. Repair or replace any damaged fuel gauge components.

18.04.05 Inspecting the Vaporizer

See Fig. 96, [LNG Vaporizer Assembly](#) for plumbing component locations.

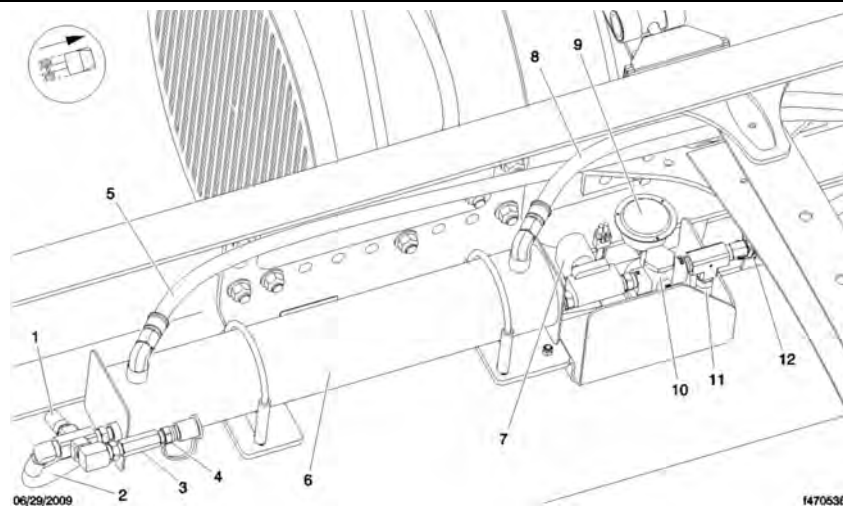

06/29/2009

1470536

- | | |
|---------------------------|--------------------------------|
| 1. Pressure Relief Device | 7. Fuel Shutoff Solenoid Valve |
| 2. Fuel Inlet Line | 8. Coolant Outlet Line |
| 3. Check Valve | 9. Pressure Gauge |
| 4. CNG Quick-Connect Port | 10. Overpressure Regulator |
| 5. Coolant Inlet Line | 11. Pressure Relief Valve |
| 6. Vaporizer | 12. Fuel Outlet Line |

Fig 96, LNG Vaporizer Assembly

1. Ensure that the vaporizer is secured to its mounting brackets and that the mounting brackets are secured to the frame. Inspect for any signs of looseness.
2. Inspect the vaporizer fuel inlet and outlet lines for signs of chafing, damage, or leaks.
3. Inspect the vaporizer coolant hoses for signs of chafing, damage, or leaks.
4. Inspect all fittings for leaks.
5. Inspect the fuel shutoff solenoid valve for signs of leaks or damage. Inspect the solenoid mounting bracket for looseness.
6. Inspect the overpressure regulator for signs of leaks or damage.
 - 6.a Ensure that the regulator is mounted securely.
 - 6.b Check the overpressure regulator fittings for signs of leaks or damage.
 - 6.c Ensure that the adjustment handle locking nut (at the bottom of the overpressure regulator) is tightened securely.
 - 6.d Inspect the pressure gauge for damage. Ensure that the gauge sight glass is clear and legible.
7. Repair or replace any leaking or damaged vaporizer components.

18.05 LNG Vacuum Integrity Testing



WARNING:

Natural gas is highly flammable. See the safety precautions listed, see General Information, Diesel Fuel Tanks and Fuel Lines in the *108SD and 114SD Plus Workshop Manual*. Failure to observe these precautions could lead to the ignition of the natural gas, which could cause serious bodily injury or death.

1. Ensure the fuel tank is between 50 and 75 percent full.
2. Check the fuel tank pressure gauge (Fig. 97, [Fuel Tank Plumbing Components](#), Item 8) to ensure that pressure is within the normal range of 120 to 150 psi (827 to 1034 kPa).

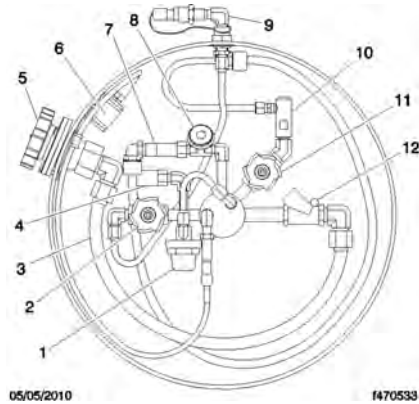

- | | |
|-------------------------------------|---------------------------------|
| 1. Pressure Control Regulator | 7. Primary Relief Valve |
| 2. Vapor Shutoff Valve | 8. Tank Pressure Gauge |
| 3. Fuel Fill Hose | 9. Fill Vent Fitting |
| 4. Secondary Relief Valve (red cap) | 10. Excess Flow Valve |
| 5. Fuel Fill Fitting | 11. Fuel Shutoff Valve (liquid) |
| 6. Fuel Level Sender Box | 12. Fill Check Valve |

Fig 97, Fuel Tank Plumbing Components

3. Inspect the fuel tank for signs of frost spots or outer surface sweating. Frosting or condensation on the outer surface of the fuel tank may indicate a loss of vacuum.
4. Check for a large variance in temperatures between the fuel tank and the fuel tank shroud. A large variance in temperatures between the fuel tank and the shroud may indicate a loss of vacuum.
5. Operate the vehicle for ten minutes. Shut down the engine, apply the parking brakes, and note the time.
6. Wait fifteen minutes after shutting down the engine, then record the fuel tank pressure and note the time.
7. Allow the vehicle to stand for at least eight hours, then record the fuel tank pressure again.
8. Use Table 42, [Vacuum Integrity Test Results](#) to determine whether the pressure increase is within an acceptable range.

Pressure Increase Over Eight-Hour Period	Remedy
Less than 20 psi (138 kPa)	None – Tank is normal
20 to 50 psi (138 to 345 kPa)	Monitor tank and test vacuum integrity again at next maintenance date
More than 50 psi (345 kPa)	Remove vehicle from service and evacuate the tank per the tank manufacturer's instructions

18.06 Inspecting the CNG Fuel System

**WARNING:**

Natural gas is highly flammable. See the safety precautions listed in General Information, Diesel Fuel Tanks and Fuel Lines in the *108SD Plus and 114SD Plus Workshop Manual*. Failure to observe these precautions could lead to the ignition of the natural gas, which could cause serious bodily injury or death.

The following inspections must be performed by a qualified technician, in accordance with the manufacturer's established inspection criteria.

**NOTICE:**

Do not use a high-pressure washer or steam cleaner on natural gas fuel system plumbing components, as this can introduce moisture and contaminants into the threads of the fittings and damage the sealants.

Gas detection sensors are located on the cab overhead console and in the engine compartment on the frontwall. The sensors are located in high areas, where rising gas vapors will pass by or accumulate. Do not use a high-pressure washer, steam cleaner, or silicone-based chemicals on the gas detection sensors, as this may permanently disable the sensors. When cleaning the vehicle, cover the sensors with a plastic covering. Keep the sensors covered until the area has been cleared of any cleaning fumes. Harsh chemicals and extremely high temperatures may damage the sensor.

Use a bubble solution to check for leaks while performing the following inspection.

1. Inspect the fuel cylinders for dents or other signs of damage.
Replace any leaking fuel cylinders.
2. Ensure that the fuel cylinders are secured within the fuel cylinder storage box.
3. Ensure that the fuel cylinder storage box is secured to the frame. Inspect for any signs of looseness. If necessary, tighten the storage box mounting bolts 160 lbf·ft (217 N·m). See Fig. 98, [Fuel Cylinder Storage Box Mounting Bracket \(passenger side shown\)](#).

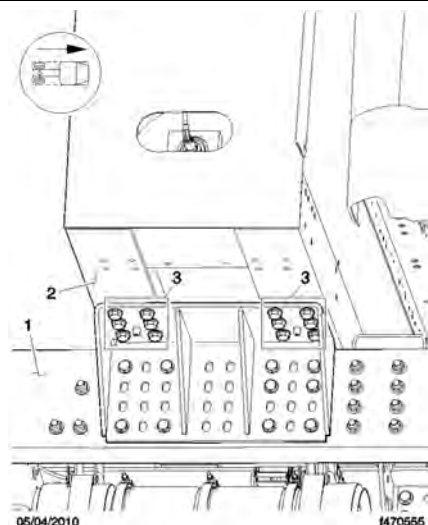

1. Frame Rail
2. CNG Fuel Cylinder Storage Box

3. Mounting Bolts (qty 12 per side)

Fig 98, Fuel Cylinder Storage Box Mounting Bracket (passenger side shown)

NOTE: During initial pre-delivery inspection (PDI), tighten the storage box mounting bolts (shown in Fig. 98,, page 178) 180 lbf·ft (244 N·m).

4. Inspect the fuel fill port for signs of damage or leaks. Ensure the port dust cover and the O-ring inside the port are both present and in good condition. See Fig. 99, [CNG Fuel Panel](#).

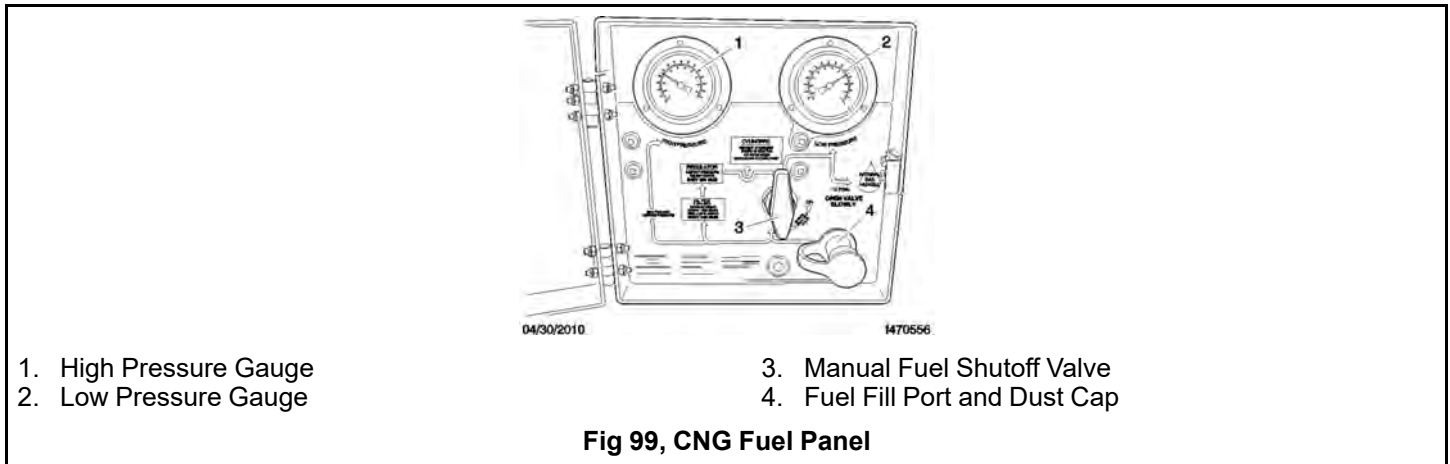

5. Inspect the pressure gauges on the fuel box for cracks. Ensure the indicator needles are present and in working condition. Inspect the gauge faces for accuracy and legibility.
6. Ensure blue caps are present on all pressure relief devices. Each fuel cylinder is equipped with two caps (one on each end), which are visible on the back of the CNG fuel cylinder storage box. One cap is located on the pressure relief valve on the inboard side of the CNG fuel box, next to the fuel outlet line. Check the primary relief valve on the inboard side of the CNG fuel box for signs of damage or leaks.
7. Check the following components for signs of damage or leaks:
 - manual fuel shutoff valve
 - fuel cylinder shutoff valves (see Fig. 100, [CNG Fuel Cylinder Storage Box \(5-cylinder system shown\)](#))
 - coolant hoses and fittings
 - fuel lines and fittings
 - all fittings, connections, and joints

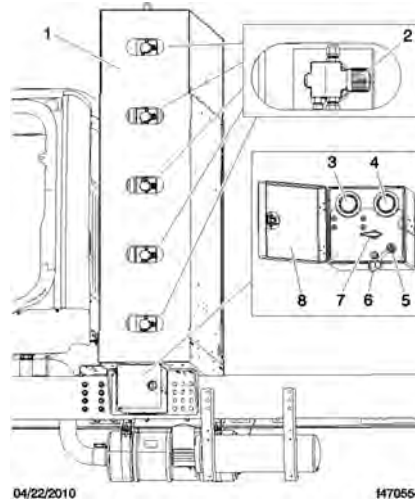

- | | |
|---|---------------------------|
| 1. Fuel Cylinder Storage Box | 5. Fuel Fill Port |
| 2. Fuel Cylinder Shutoff Valves (qty 5) | 6. Dust Cap |
| 3. High-Pressure Gauge | 7. Manual Shutoff Valve |
| 4. Low-Pressure Gauge | 8. Fuel Panel Access Door |

Fig 100, CNG Fuel Cylinder Storage Box (5-cylinder system shown)

8. Replace leaking or damaged fuel lines. Repair or replace leaking or damaged fittings.

18.07 Replacement of the CNG High-Pressure Fuel Filter Element

CNG filter element replacement cycles are an important factor in maintaining the CNG fuel system integrity and ensuring maximum operating performance. Actual frequency of the filter element replacement could increase or decrease depending on the cleanliness of the fill station fueling system.

1. Shut down the engine and apply the parking brake.
2. Close the CNG fuel cylinder shutoff valves.
3. Start the engine and let it idle until the fuel lines are empty and the engine stops. The gauges on the fuel panel should now read at or near 0 psi.
4. Close the manual fuel shutoff valve on the fuel panel.
5. Remove the two capscrews that secure the access cover to the fill panel, then remove the access cover. See Fig. 101, [CNG Fuel Panel Assembly](#). Save the capscrews for reinstallation.

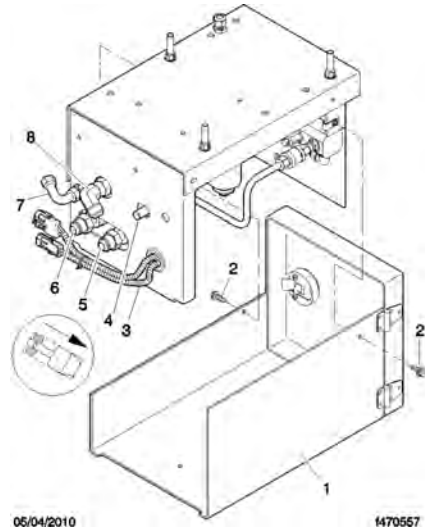

- | | |
|----------------------------------|--|
| 1. Fuel Panel Access Cover | 5. Coolant Outlet Line |
| 2. Capscrews (qty 2) | 6. Coolant Inlet Line |
| 3. Wiring Harness | 7. Fuel Inlet Line (to fuel cylinders) |
| 4. Pressure Relief Valve and Cap | 8. Fuel Outlet Line (to engine) |

Fig 101, CNG Fuel Panel Assembly

6. Slowly open the bleed valve on the manifold to relieve remaining fuel pressure within the system. See Fig. 102, [CNG Fuel Panel Components](#).

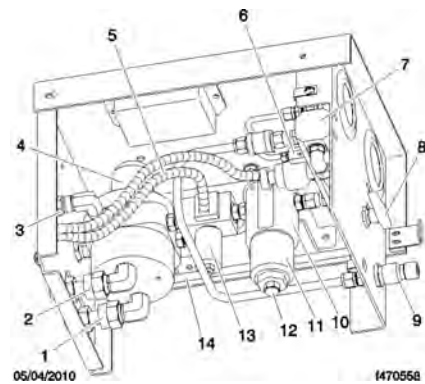

- | | |
|--------------------------|------------------------------|
| 1. Coolant Inlet Port | 8. Manual Fuel Shutoff Valve |
| 2. Coolant Outlet Port | 9. Fuel Fill Port |
| 3. Pressure Relief Valve | 10. Filter Housing |
| 4. Pressure Regulator | 11. Filter Bowl |
| 5. Wiring Harness | 12. Filter Drain Plug |
| 6. Manifold Bleed Valve | 13. Solenoid Valve |
| 7. Manifold | 14. Fuel Line To Cylinders |

Fig 102, CNG Fuel Panel Components

IMPORTANT: Some pressure may remain in the fuel system between the solenoid valve and the engine. Use caution when loosening fittings, as a small amount of gas may leak out.

7. Put a clean receptacle under the filter assembly. Using a 1-1/4-inch wrench, unscrew the filter bowl from the filter housing.

8. Remove and discard the filter element.
9. Install a new filter element in the filter housing.
10. Inspect the O-ring on the filter housing for damage or cracks. If necessary, replace the O-ring.
11. Install the filter bowl on the filter housing. Tighten 90 lbf·ft (122 N·m).
12. Close the bleed valve on the manifold and open the manual fuel shutoff valve on the fuel panel.
13. Open the fuel cylinder shutoff valves.
14. Using a methane detector, leak test all fuel system components between the fuel cylinders and the solenoid valve. A bubble solution can be used to pinpoint the exact location of leaks.
Repair or replace any leaking components.
15. Using the two capscrews removed previously, install the access cover on the fill panel.

18.08 Inspection of the CNG Fuel Cylinder

Have a qualified inspector inspect compressed natural gas (CNG) fuel cylinders for damage or deterioration. Note cuts, cracks, gouges, abrasions, discoloration, broken fibers, loose brackets, damaged gaskets or isolators, heat damage, or other problems.

Refer to Compressed Gas Association (CGA) pamphlet C-6.4, **Methods for External Visual Inspection of Natural Gas Fuel Containers and Their Installations**, for inspection requirements and inspector qualifications.

For more information, go to www.cganet.com.

After inspection, an accurate and reliable written report should be provided for each container inspected. Place an inspection label stating the inspection date and inspecting agency identification on each container.

19.01 Safety Precautions 184

19.02 Replacement of the CAT CGI Bellows 184

19. Exhaust

19.01 Safety Precautions

Safety Precautions in this section apply to all procedures within this group.



DANGER:

When working on the vehicle, shut down the engine or motor, set the parking brake, and chock the tires. Before working under the vehicle, always place jack stands under the frame rails to ensure the vehicle cannot drop. Failure to follow these steps could result in serious personal injury or death.

19.02 Replacement of the CAT CGI Bellows

On vehicles with CAT EPA07 compliant engines, replace the CGI bellows at the M3 maintenance interval to prevent a later failure.



NOTICE:

A leak in the CGI piping, including the bellows, will allow unfiltered air and contaminants into the engine intake, and can cause serious engine damage.

1. Park the vehicle, set the parking brake, chock the wheels.
2. Open the hood.
3. Remove the right side inner fender/splash shield as needed.
4. Remove the CGI piping between the engine and aftertreatment device (ATD). See Fig. 103, [CAT EPA07 Exhaust Installation with CGI Bellows](#).

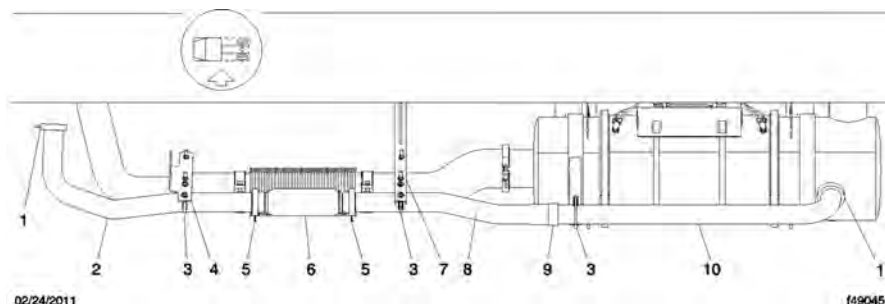

- | | |
|-------------------------------|------------------------------|
| 1. Clamp | 6. CGI Bellows |
| 2. Inlet Pipe | 7. Center Pipe-Support Brace |
| 3. U-Clamp | 8. Center Pipe |
| 4. Forward Pipe-Support Brace | 9. Clamp |
| 5. Slip Clamp | 10. Outlet Pipe |

Fig 103, CAT EPA07 Exhaust Installation with CGI Bellows

5. On the workbench, remove the CGI bellows from the exhaust piping. Do not damage the piping.

**NOTICE:**

When shortening the CGI pipe(s), it is critical to leave a minimum of 1 inch (25.4 mm) of straight pipe on the end of each CGI pipe to allow for pipe insertion and clamp clearance. Failure to do this could result in an exhaust leak, which in this case may allow ingestion of contaminants into the engine causing engine damage.

NOTE: The following step, and its substeps, is to be done without the bellows installed. This will align the pipes so that the bellows can be installed correctly.

6. Install the CGI piping (without CGI bellows) and align piping.
 - 6.a Attach the aft CGI pipe to the ATD.

**NOTICE:**

When the CGI pipes and bellows are installed, there should be approximately 3/4 inch (19 mm) clearance from the main bellows. Contact between the bellows could result in an exhaust leak, which in this case may allow ingestion of contaminants into the engine causing engine damage.

- 6.b Attach the forward CGI pipe to the engine.
 - 6.c Use a straightedge to align the pipes so that the pipe ends that attach to the bellows are parallel and concentric.
7. Once the pipes are aligned, measure the pipe gap between the CGI pipes and record the distance. See Fig. 104, [Measuring the Pipe Gap \(typical\)](#), Ref. A.

The existing pipe gap is designed at 10 inches (254 mm). A 10.75 inches (273 mm) pipe gap is required for the replacement CGI bellows and clamps. This requires one or both of the CGI pipes to be shortened.

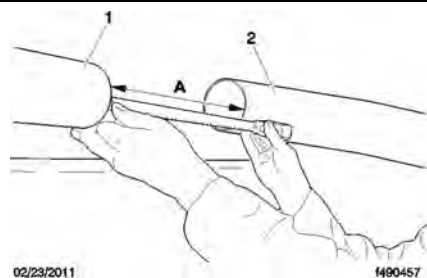

- A. Measure the pipe gap.
1. CGI Aft Pipe

2. CGI Forward Pipe

Fig 104, Measuring the Pipe Gap (typical)

8. Using a yellow paint pen, mark the pipes 1.5 inches (38 mm) in from the end of each pipe. These two marks will be used to center the bellows between the two pipes.
9. Once the pipes are correctly aligned and separated at the correct distance, secure the aft CGI pipe to the ATD and to any CGI pipe support brackets.

10. Remove the forward CGI pipe from the truck.
11. Slide the slip clamp, with the retaining ring and graphite gasket ring, on the aft CGI pipe. See Fig. 105, [Aft Facing Slip Clamp Installation](#) for proper installation.

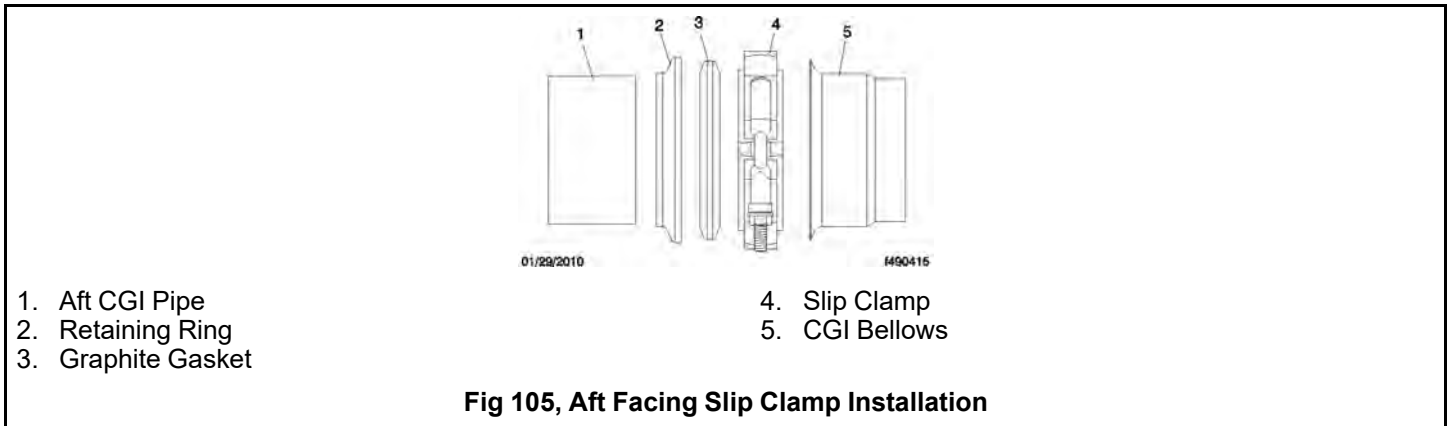

12. Slide the new bellows onto the aft CGI pipe as far as it will go. See Fig. 106, [CGI Bellows Installation](#), Ref. A. Measurement A should be at least 7/16 inch (10 mm) past the face of the flange.

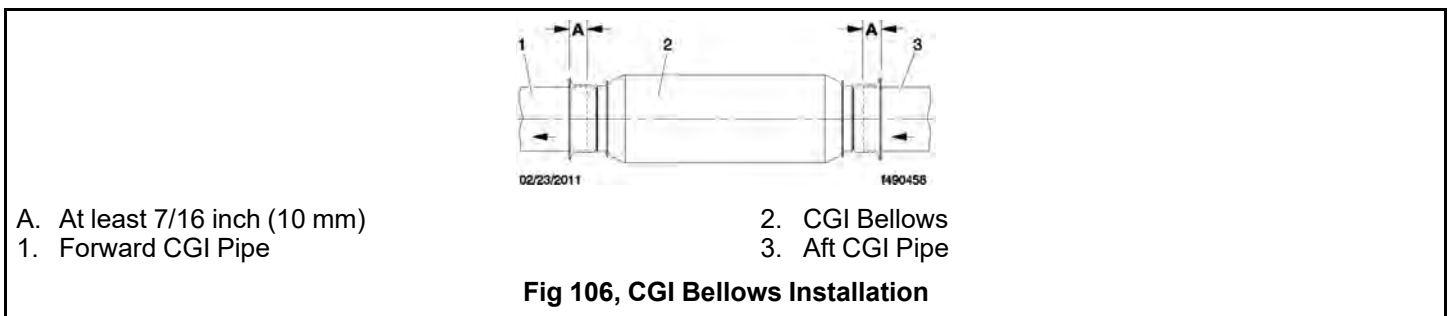

13. Install the slip clamp with the retaining ring and graphite gasket ring onto the forward CGI pipe. See Fig. 107, [Forward Facing Slip Clamp Installation](#) for proper installation.

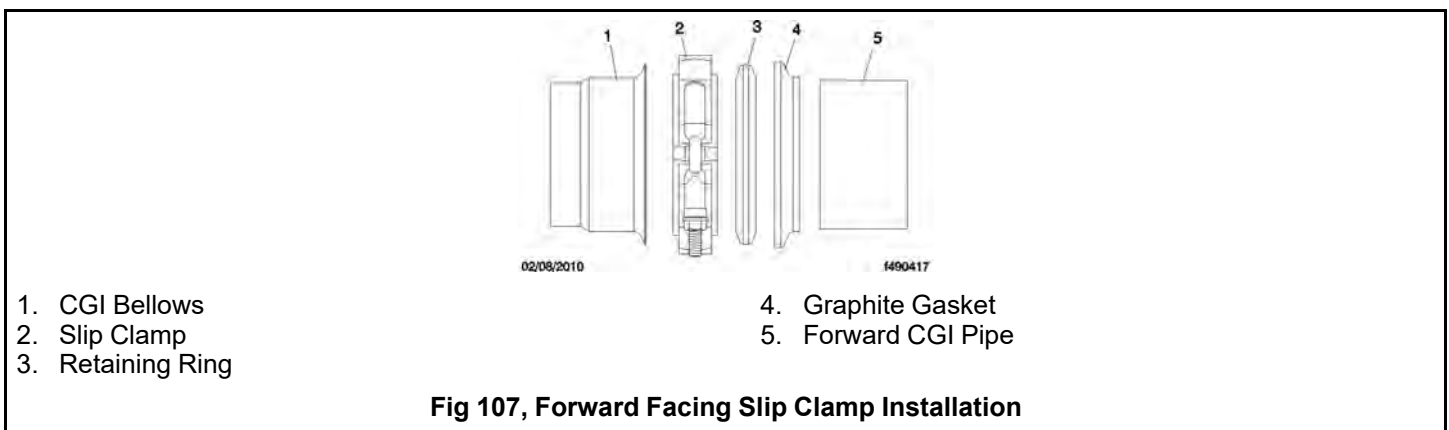

14. Slide the end of the forward CGI pipe into the bellows, and properly align the pipe.
15. Secure the forward CGI pipe to the engine and any CGI pipe support brackets.
16. Using the yellow marks, center the bellows between the exhaust pipes. Verify that the pipe is inserted at least 7/16 inch (10 mm) past the face of the flange. See Fig. 106, [CGI Bellows Installation](#), Ref. A.
17. Install the slip clamps on the bellows. Tighten the slip clamps 11 lbf·ft (15 N·m).

18. Start the engine and check for exhaust leaks. Tighten any clamps as needed.

20.01 Trailer Cable Inspection and Cleaning.....	190
20.02 Inspection of the Electrical Component	190

20. Electrical, Instruments and Controls

20.01 Trailer Cable Inspection and Cleaning

1. Disconnect the trailer electrical cables from the sockets at the cab.
2. Inspect the cables and sockets for evidence of corrosion, and clean as necessary. If a socket is too badly corroded to clean, replace it. Freightliner recommends also replacing the socket's harness as well, if the corrosion has gotten into the wires and connectors inside the socket.

IMPORTANT: If using a spray cleaner to remove corrosion, be careful to protect any surrounding painted surfaces.

3. Coat the inside of the sockets with a lithium-based dielectric grease such as Lubriplate FLP DS–ES.
4. Connect the cables.

20.02 Inspection of the Electrical Component

1. Park the vehicle on a level surface, apply the parking brakes, and shut down the engine. Chock the tires.
2. Disconnect the batteries.
3. Inspect the condition of the electrical component. Check for signs of excess dirt/debris build up on or around the component. If exterior cleaning is needed for a thorough inspection, clean exterior debris from the component using a dry method such as a vacuum cleaner or using an electrical contact cleaner such as CRC QD® Electronic Cleaner.
4. Check all mounting points for loose, broken, or missing parts. The component must be securely mounted. All loose, broken, or missing parts must be repaired to maintain proper component function.
5. Inspect the component protective cover for proper fit and function. Inspect the cover for cracks, broken mounting, missing sealing surfaces, warped or bulged surfaces. The cover must prevent moisture and debris from entering the components protected area. Missing, leaking, or damaged covers will result in moisture and debris entering the component and will result in component failure. When it is determined that a cover has not properly prevented moisture and debris from entering the component, the entire component must be replaced.
6. Inspect the component exterior for signs of thermal distortion, warping, bulging, discoloration, amperage related heating, color variance or shading across the component which could be a sign of internal failure requiring replacement of the component. The root source causing conditions of high heat, excess amperage, and/or circuit overload component failures must be diagnosed and repaired prior to replacing the component.
7. Inspect component housing sub-assembly clips and fasteners for correct fit and location and that component sub-assembly housing seams are tight and secure. Missing, leaking, or damaged component housings must be replaced.
8. Check main power cable connections for a clean and secure fit. Connections should be free of corrosion, dirt and moisture. Connections should not have signs of thermal distortion, warping, discoloration, high amperage heating or discoloring. If needed, disconnect the cables, scrub and clean as needed using a nylon brush. Clean debris with a vacuum or electrical contact cleaner such as CRC QD® Electronic Cleaner, inspect terminals and mating contact terminal plating. If the terminal plating exhibits signs of unrecoverable corrosion, replace the component and terminal. Indications of unrecoverable corrosion on terminal plating are:
 - Heavy staining that cannot be cleaned off with nylon brush or contact cleaner;
 - erosion and pitting on terminal plating causing uneven surfaces; or
 - discoloration caused by outer layer of plating being removed by corrosion or wear exposing the under layer material of terminal.
9. Check all electrical connectors for correct fit and that the connector locking tabs are in place and will hold the connector firmly into the component. Inspect connector terminals for signs of corrosion, thermal distortion, warping, discoloration, high amperage heating or discoloring. If needed, remove connectors and terminals, scrub and clean as needed

using a nylon brush. Clean debris with a vacuum or electrical contact cleaner such as CRC QD® Electronic Cleaner, inspect terminals and mating contact terminal plating. If the terminal plating exhibits signs of unrecoverable corrosion, replace the component and terminal.

10. Inspect sealed harness connectors for presence of connector housing seals and connector pin seals designed to keep moisture and debris from entering the connector and component. Missing, leaking, or damaged seals will result in moisture and debris entering the connection and the component and will result in component failure. When it is determined that connector seals have not properly prevented moisture and debris from entering the component, replace the component and terminal.
11. Inspect component harnesses for secured routing that prevents excess harness movement and prevents the harness from pulling too tight on the connector. Inspect harnesses for signs of rubbing or chafing that could result in wire circuit damage. Damaged wiring and/or damage to harness protective wrap must be repaired and harnesses must be wrapped and secured to prevent further damage. When possible, the harnesses should be routed with a drip loop.
12. Inspect fuses and relays for correct fit, and that the terminals hold the fuses and relays firmly in place. Inspect fuses and relays for signs of corrosion, thermal distortion, warping, discoloration, and high amperage heating or discoloring. If loose or corroded, remove, inspect, clean, and replace as needed.
13. Connect the batteries.

21.01 Mirror Folding Check 194

21.02 Aerodynamic Component Inspection..... 194

21. Cab

21.01 Mirror Folding Check

For vehicles with folding main mirrors, make sure that the mirrors fold freely on the pivot points. Pivot each mirror fully forward and backward two times to break loose any debris that may affect the fold-away feature of the mirror.

21.02 Aerodynamic Component Inspection

Inspect aerodynamic components, if equipped, for structural damage, cracks, or wear. These may include:

- Cab side extenders
- Roof fairing/deflector
- Bumper
- Hood

22.01 Safety Precautions	196
22.02 Air Conditioner Inspecting	196
22.02.01 Inspection of the Refrigerant Compressor	196
22.03 Replacement of the HVAC Air Filter	197

22. Heater and Air Conditioner

22.01 Safety Precautions

Safety Precautions in this section apply to all procedures within this group.

**DANGER:**

When working on the vehicle, shut down the engine or motor, set the parking brake, and chock the tires. Before working under the vehicle, always place jack stands under the frame rails to ensure the vehicle cannot drop. Failure to follow these steps could result in serious personal injury or death.

22.02 Air Conditioner Inspecting

22.02.01 Inspection of the Refrigerant Compressor

1. Park the vehicle on a level surface, shut down the engine, and set the parking brake. Chock the tires.
2. Operate the heater and, if equipped with an air conditioner, the air conditioner to check for proper operation in all modes.
3. Open the hood.
4. Check the condition of the refrigerant compressor clutch assembly. If the friction surface of the pulley shows signs of excessive grooving due to belt slippage, replace both the pulley and the drive plate.
5. Inspect the refrigerant compressor drive belt for damage. If needed, replace the drive belt.
6. Check the tightness of the compressor mounting fasteners. The torque value for the mounting fasteners is 15 to 19 lbf·ft (20 to 26 N·m).
7. Inspect the drive plate. If the friction surface of the drive plate shows visible signs of damage due to excessive heat, make sure the refrigerant compressor turns freely. If the compressor does not turn freely, replace the drive plate and clutch assembly. See [Heating, Ventilation and Air Conditioning \(HVAC\) System General Description, Cab Heater and Air Conditioner](#) of the *108SD Plus and 114SD Plus Workshop Manual* for instructions. If the compressor does not turn freely, replace the compressor. See [Heating, Ventilation and Air Conditioning \(HVAC\) System General Description, Cab Heater and Air Conditioner](#) of the *108SD Plus and 114SD Plus Workshop Manual* for instructions.
8. Use a feeler gauge to check that the drive plate clutch clearance is 0.012 to 0.024 inch (0.3 to 0.6 mm). If the gap is not even around the clutch, gently tap down at the high areas. If the overall gap is out of specification, remove the drive plate assembly and change the shims as necessary. See [Heating, Ventilation and Air Conditioning \(HVAC\) System General Description, Cab Heater and Air Conditioner](#) of the *108SD Plus and 114SD Plus Workshop Manual* for instructions.
9. Check that the wiring harness connector is not damaged or loose. Replace the wiring harness if it is damaged.
10. Check the overall condition of the air conditioning hoses. Look for cracks, cuts, and abrasions on the hoses. Replace the damaged hoses.
11. Check for a buildup of road debris on the condenser fins. Using air pressure and a whisk broom or a soapy spray of water, carefully clean off the condenser. Be careful not to bend the fins.
12. Check the moisture indicator on the receiver-drier. See Fig. 108, [Receiver-Drier](#). If the indicator is a deep cobalt blue, the refrigerant charge is dry. If the indicator is not blue, the system is contaminated with water. If the system is contaminated, recover the refrigerant, replace the receiver drier, evacuate the system, and add a full refrigerant charge. See [Heating, Ventilation and Air Conditioning \(HVAC\) System General Description, Cab Heater and Air Conditioner](#) of the *108SD Plus and 114SD Plus Workshop Manual* for instructions.

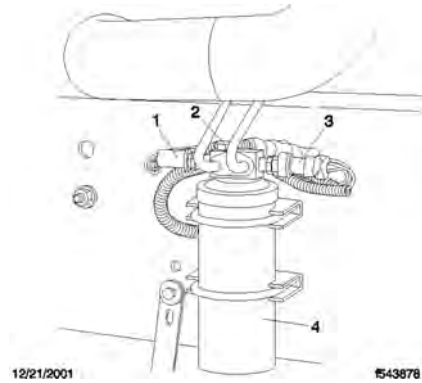

1. Fan Cycling Switch
2. Moisture Indicator

3. Binary Switch
4. Receiver-Drier

Fig 108, Receiver-Drier

13. Close the hood and remove the chocks from the tires.

22.03 Replacement of the HVAC Air Filter

The HVAC air filter must be replaced every six months or 60,000 miles (97 000 km) to permit proper operation of the HVAC system.

1. Park the vehicle on a level surface, shut down the engine, and set the parking brake. Chock the tires.
2. Remove the lower HVAC cover in the cab. See [General Information, Windshield](#) in the *108SD Plus and 114SD Plus Workshop Manual* for instructions.
3. Disconnect the wiring harness from the evaporator probe.
4. Remove the capscrews that attach the evaporator service cover to the HVAC assembly. Remove the evaporator service cover.
5. Pull the filter out of the HVAC assembly.
6. Install a new filter in the HVAC assembly. Be sure that the arrow on the filter is pointing toward the evaporator. See [Fig. 109, HVAC Assembly Filter](#).

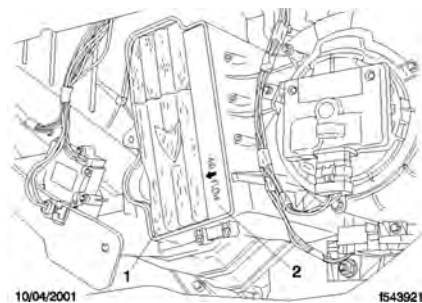

1. Evaporator

2. Filter

Fig 109, HVAC Assembly Filter

7. Remove the condensate seal from the evaporator service cover and install a new condensate seal on the cover.
8. Using capscrews, attach the evaporator service cover to the HVAC assembly.
9. Connect the wiring harness to the evaporator probe.
10. Attach the lower HVAC cover to the dash panel. See [General Information, Windshield](#) in the *108SD Plus and 114SD Plus Workshop Manual* for instructions.

11. Remove the chocks from the tires.

23.01 Hood Rear Support Lubrication200

23. Hood, Grille, and Cab Fenders

23.01 Hood Rear Support Lubrication

1. Park the vehicle on a level surface, shut down the engine, and set the parking brake. Chock the tires.
2. Open the hood.
3. Clean both the hood- and cab-mounted hood rear support components with a soapy water solution.
4. Cover all contact surfaces of the hood rear support brackets and isolators with an approved multi-purpose, lithium-complex, soap-based grease; see Table 43, [Approved Suppliers of Multi-Purpose Lithium Grease](#).

Supplier	Grease
Chevron	Delo Heavy Duty EP
Exxon	Unirex EP2
Mobil	Mobil Grease XHP 222
Shell	Retinax LC Grease
Texaco	Starplex 2

5. Close the hood.



CONTACT INFORMATION

For questions, please create a Service Technical Request using the DTTS Application on the DTNA Portal.