



Minotour Operator's Manual



School Bus

 **WARNING:** Breathing diesel engine exhaust exposes you to chemicals known to the State of California to cause cancer and birth defects or other reproductive harm.

- Always start and operate the engine in a well-ventilated area.
- If in an enclosed area, vent the exhaust to the outside.
- Do not modify or tamper with the exhaust system.
- Do not idle the engine except as necessary.

For more information go to www.P65warnings.ca.gov/diesel.

If you believe that your vehicle has a defect which could cause a crash or could cause injury or death, you should immediately submit a complaint to the Administrator, National Traffic Safety Administration, 400 Seventh Street, SW., Washington, DC 2059, or call the toll-free Vehicle Safety Hotline at 1-888-327-4236 (TTY: 1-800-424-9153); or go to <http://www.safercar.gov>, in addition to notifying THOMAS BUILT BUSES, INC.

If NHTSA receives similar complaints, it may open an investigation, and if it finds that a safety defect exists in a group of vehicles, it may order a recall and remedy campaign. However, NHTSA cannot become involved in individual problems between you, your dealer, or THOMAS BUILT BUSES, INC.

TABLE OF CONTENTS

INTRODUCTION	1
OPERATOR'S COMPARTMENT	5
OPERATING THE VEHICLE	15
EMERGENCY EQUIPMENT	19
GENERAL INFORMATION	25
MAINTENANCE	71

To The Operator

This manual has been prepared to acquaint you with the necessary information for the the proper operation of your Thomas Bus body.

A thorough knowledge of the operating controls is essential to the proper transit and comfort of passengers.

The information and illustrations contained in this manual are based on the latest product information available at the time of publication. Some procedures

and illustrations will pertain to optional equipment. Thomas Built Buses, Inc. reserves the right to make changes at any time without notice.

We would like to say "Thank You" for choosing the Thomas product line to fill your transportation needs.

This manual should remain with the bus when sold to provide the next owner with important operation and maintenance information.

Safety

Shown below are the safety alert symbols. When you see these symbols and words in this manual, be alert to the potential for personal injury or property damage.

Follow the recommended precautions and safe operating practices.

Danger

The danger message alerts the operator to a hazardous situation or unsafe practice that **will** result

in serious injury or death.

Warning

The warning message alerts the operator to a potentially hazardous situation or unsafe practice that

could result in injury to the operator and/or damage the bus.

Caution

The caution message alerts the operator to a potential hazardous situation or unsafe practice that **may** result

in minor or moderate injury or could result in property damage only.

Important

The important message identifies potential problems which could cause minor damage to the body of the

bus.

Note

The note message helps to clarify a previous statement. It also identifies "nice-to-know" information.

MINOTOUR

Important Notice

Your Thomas Built Bus Body has been manufactured in strict compliance with all the applicable FEDERAL MOTOR VEHICLE SAFETY STANDARDS (FMVSS). **We strongly advise against making any changes or modifications that will in any way violate this compliance.**

Thomas Built Buses will not be responsible for any change or modification occurring to the bus after its purchase that violates these FMVSS standards.

Modifications or Additions to Your Vehicle

Installation of additional or non-standard components or attachments as well as alteration or removal of components can adversely affect the safety or performance of your vehicle.

Any changes will void the Thomas Built Buses warranty.

Be sure to observe the limitations and specifications set forth in your Operator's Manual.

Vehicle Modification Disclaimer Policy

THOMAS BUILT BUSES, INC. is not responsible for any direct or indirect consequence of any modification or alteration made to its products by anyone other than the THOMAS factory. Please be advised that such modifications may VOID the FEDERAL and/or STATE CERTIFICATION, and the THOMAS BODY LIMITED WARRANTY, and/or the THOMAS PREMIERE PROTECTION PLAN.

The limited warranties of THOMAS exclude:

"Components or systems which have been altered or modified without the express prior, written authorization of the company."

Examples of such modifications are, but are not limited to, the following:

- Mounting a THOMAS body on a different chassis than the original,
- Any component alteration that affects GAWRF, GAWRR, and/or GVWR,
- Any component alteration that affects any FMVSS certification,

- Seating capacity or configuration modification,
- Addition or deletion of any passenger entrance or exit,
- Basic body structural alteration,
- Modification of the body-to-chassis mounting system,
- Electrical system/component alteration,
- Addition of after-market components, such as:
 - Lifts
 - Air conditioning

Certification and Data Sticker

The computer generated Certification and Data Sticker are attached to the inside roof liner above the driver's window or on the front bulkhead.

The Certification Sticker certifies compliance with all Federal Motor Vehicle Safety Standards in effect at time of manufacture.

Other information included are Date of Manufacture, GAWR Front, GAWR Rear, GVWR, Tire Data, VIN, Vehicle Type, Body ID, and Capacity.

Whenever contact is made with a dealer, authorized service agent, or Thomas Built Buses concerning warranty, parts, or service, these numbers must be

given to identify the unit. The three sets of numbers are:

1. Chassis Identification Number - When concerning the chassis of a Thomas product.
2. Order Number - The first five digits in the Body Identification number.
3. Body Number - The second seven digits in the Body Identification number.

The VIN (Vehicle Identification Number) is assigned by the chassis manufacturer and contains information such as manufacturer, engine type, body style, and order number.

Vehicle Identification Number (VIN)

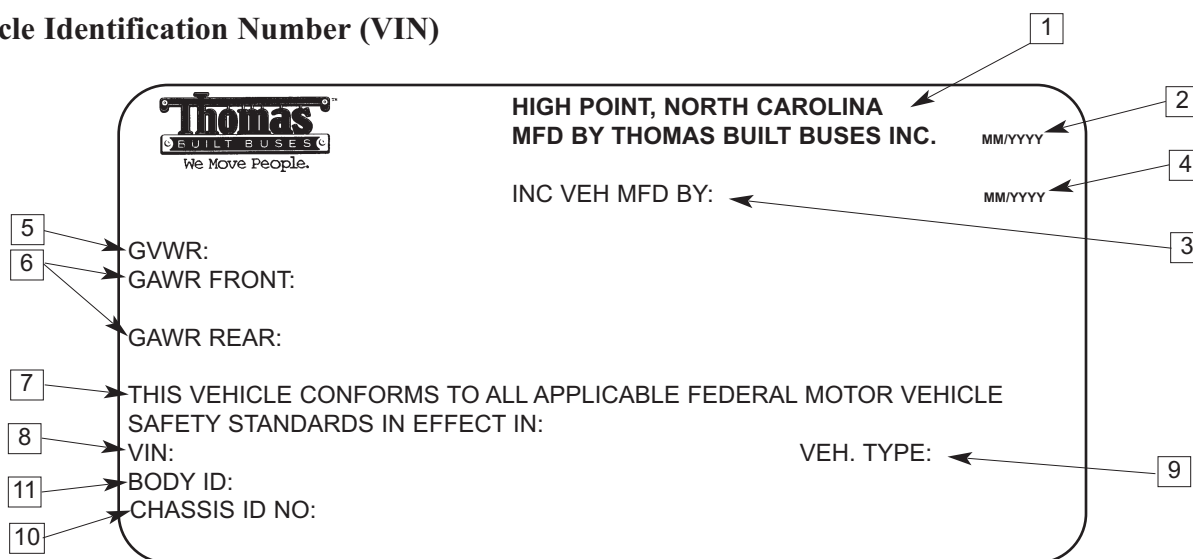

The following information will be on the standard label:

1. Name of Manufacturer.
2. 2-Digit Month and 4-Digit Year Manufacture. Body Start Date: Example: (MM/YYYY)
3. INC VEH MFD BY: (Chassis Manufacturer). (Included only when unit is built in two or more stages; see CFR 44 SEC. 564.5; Not applicable if chassis is built by TBB).
4. 2-Digit Month and 4-Digit Year of INC VEH MANUFACTURED: EXAMPLE: (MM/YYYY)
5. GROSS VEHICLE WEIGHT RATING. (Weight in KG and Lb.).
6. GROSS VEHICLE AXLE RATING (FRONT & REAR) (Weight in KG and Lb.); RIM SIZE, TIRE SIZE, COLD AIR PRESSURE (in KPA, PSI), LOAD RATING, SINGLE OR DUAL WHEEL.
7. STATEMENT: THIS VEHICLE CONFORMS TO ALL APPLICABLE FEDERAL MOTOR VEHICLE SAFETY STANDARDS IN EFFECT IN: (2-DIGIT, 4-DIGIT YEAR OF MANUFACTURE. EXAMPLE (MM/YYYY)
8. VEHICLE IDENTIFICATION NUMBER: (17 CHARACTERS)
9. VEHICLE TYPE: ("S", "N", "MPV", "MFSAB").
10. CHASSIS ID NUMBER. (15 CHARACTERS)
11. BODY ID. NUMBERS. (ORDER NO., BODY NO., MODEL)

MINOTOUR

Delivery Inspection - New Vehicle

Each new Thomas bus has been inspected before delivery. Every precaution has been taken to provide the user with a complete and trouble-free bus.

time of delivery and throughout its service life. Any discrepancies or omissions should be reported to the selling dealer immediately.

There are certain steps that must be taken to continue the assurance of a trouble-free bus. Proper inspection and maintenance of the bus is a necessity from the

First Thirty Days

In addition to the Delivery Inspection, a one-time preventive maintenance inspection should be performed after the first thirty days of operation.

These are areas that should receive attention on any new vehicle.

Body

- Tighten all mounting clips and bolts, then retighten every six months thereafter.
- Tighten seat leg and wall rail bolts, then retighten every ninety days thereafter.
- Tighten door control mounting bracket, then retighten every six months thereafter.
- Remove heater hose covers and tighten all hose clamps.
- Wash bus only with clean water for the first thirty days.
- Wax bus with a good automotive wax after the first thirty days.

Towing



Caution: Thomas Built Buses recommends that when a Minotour requires towing, that it be towed from the front whenever possible.

If the need arises for the unit to be towed from the rear, the towing operator should make sure the steer axle tires are rated high enough to support the unit weight when towing from the rear. It is also recommended that when towing from the rear the distance towed is less than 30 miles at 45 mph.

OPERATOR'S COMPARTMENT

This section provides the operator with important operational and general information. The following is the *Overhead Switch Panel*.

It is important to carefully read and understand the following pages before operating the bus. A proper

understanding of component location, function, and operation is important to the proper operation of the bus.

For information concerning the Driver's Seat see the chassis manual provided with the vehicle.

Overhead Switch Panel

The *Overhead Switch Panel* contains the controls for bus heaters and defrosters, destination sign lights, and other standard and optional body group controls. All switches are easily accessed by the operator. A

typical switch panel is shown below. The layout of your switch panel may differ slightly due to bus specifications and selected options.



1. Heated Mirror Switch (Optional)
2. I.D. Marker Switch, ON-OFF, LED
3. Sign Switch
4. Lift Switch (Optional)
5. Lift (Warning) Pilot Light, Red Lens
6. Lift Door Pilot Lamp, Red Lens
7. Brake Pilot Light, Red Lens
8. Fan Switch, ON-ON-ON, LED
9. Blank Switch, V-Series Cutout
10. Warning Switch, CENTER ON, DOWN OFF, Amber LED
11. Pilot Light, Double Amber & Red
12. Blank Switch, V-Series Cutout
13. Blank Switch, V-Series Cutout
14. Front Heater Fan Switch
15. Blank Switch, V-Series Cutout
16. Interior Light Switch, ON-OFF, LED
17. Compartment Light Switch (Optional)
18. Driver's Dome Switch, ON-OFF, LED

MINOTOUR

Mirror Defroster Switch (Optional)

The mirror defroster switch energizes the defroster strips in the exterior mirrors



Marker Lights Switch

The marker light switch energizes the bus marker lights.



Sign Switch, ON-OFF, LED (Optional)

Controlled by the bus operator, must be **ON** to operate the sign.



OPERATOR'S COMPARTMENT

Lift Switch (Optional)

With the "Lift Switch" enabled, and the red warning light ON; lift has been activated.



Lift (Warning) Pilot Light Red (or Green) (Optional)

With the Lift Switch enabled and the red warning light ON; lift has been activated.



Lift Door Pilot Light, Red Lens

Lamp illuminates when lift door handle is not fully latched.



MINOTOUR

Brake Pilot Light

With the "Brake Switch" enabled, and the red warning light ON; brake has been activated.



Fan Switch

Enables the defroster fan for windshield cleaning. The fans operates at low or high speeds.



Blank Switch Cutout

Blank panels are used to fill in openings in the switch panel where switches are not used. The panels may be removed and replaced with switches for additional options which may be installed aftermarket.

Refer to disclaimer concerning installation of aftermarket electrical components on page 2 of this manual.



Warning Switch, CENTER ON, DOWN OFF, Amber LED

Eight-light warning system controls the amber and red warning lights mounted on the four corners of the exterior of the vehicle. These lights are activated at various times by the driver as necessary.

This system requirements vary from state to state. Follow your state requirements for proper operation.



Pilot Light, with Warning Light Symbol (Optional)

Amber and red flashing lights coordinated with eight-light warning system.



Front Heater Fan Switch

Enables the operator to control the fan speed of the front heater. The fan operates at HIGH or LOW speeds.



MINOTOUR

Interior Light Switch

The interior light switch energizes all the bus interior dome light except the one directly above the driver.



Compartment Light Switch (Optional)

Located on the overhead switch panel, enables driver to activate the light in the electrical compartment over driver.



Dome Light Switch, LED

The driver's dome light switch enables the driver to energize the dome light above the operator's compartment.

When installed, the driver can control the brightness level of the dome light by rotating an optional rheostat-type switch shown on page 12 of this manual.



Doran Monitor, Exterior 4 or 8 Light (Optional)

The exterior light monitoring system (4, 8, 12, 16) monitors the condition of those exterior bus lights identified by the type of monitor board. The monitor provides the operator with the location of any malfunctioning light. In the event that a bulb has become damaged or burned-out or the circuit is interrupted, a corresponding light on the panel goes off. The panel should be checked daily to verify the operation of all exterior lights.



Rear Heater Fan Switch

The rear heater fan switch enables the bus operator to control the fan speed of the underseat heaters. The fans operate at either **LOW** or **HIGH** speed.



Underseat Heater Fan Switches

The underseat heater fan switches enable the bus operator to control the fan speed of the underseat heaters. The fans operate at either LOW or HIGH speed.



MINOTOUR

Dome Light Switch, Rheostat-Type (Optional)

When the dome light switch is enabled the operator can control the brightness level of the dome light by rotating the knob.



GM

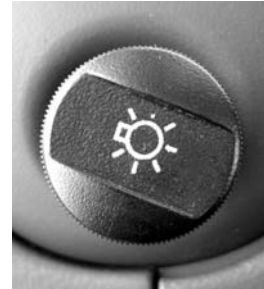

Ford

Noise Switch, LED Yellow

Maintained switch mounted in overhead switch panel to turn off all noise-producing accessories simultaneously, including heater blowers, defroster fans, and auxiliary fans that may be in use when the bus is approaching railroad crossings.

The switch will NOT control any chassis manufactured items, including chassis OEM supplied radios, if so equipped.



Electric Door Switch, Paddle-Type (Optional)

Switch is used to activate an electric-operated entrance door. Momentary-type switch that requires driver to operate until fully open or closed.



OPERATOR'S COMPARTMENT

Strobe Light Switch (Optional)

The strobe light is a separate warning light affixed to the top of the bus in various locations. The strobe improves the visibility of a stopped school bus in all driving conditions.



Crossing Arm Deactivation Switch - Electric, LED Yellow

Switch deactivates the crossing control arm after warning lights have been activated.



Microphone Jack

Microphone jack is installed when a remote-mounted microphone is ordered. Hole will be plugged when not ordered.



MINOTOUR

Emergency Warning Switch (Optional)

Will activate the red warning lights and stop sign for emergency purposes overriding normal operation of the four or eight-light warning system.



Remote Mirror Switches (Optional)

The switch on the left, controls the left (driver's side) mirrors. The left position on the left switch, as shown, adjusts the left upper mirror; right position on the left switch, adjusts the left lower mirror.

The switch on the right, controls the right (passenger's side) mirrors. The left position on the right switch, as shown, adjusts the right upper mirror; right position on the left switch, adjusts the right lower mirror.

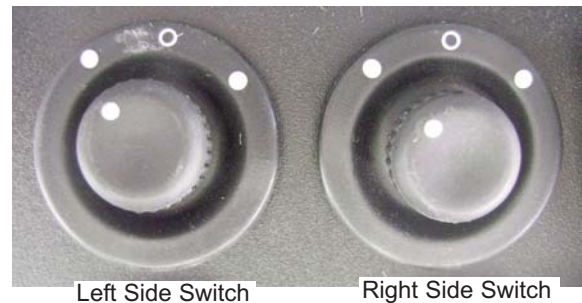

OPERATING THE VEHICLE

This section provides the operator with important operational information. The following pages contain helpful driving tips, information for daily operation, and procedures for operation in emergency or inclement weather conditions.

It is important to carefully read and understand the following pages before operating the bus. A proper understanding of component location, function, and operation is important to the safe operation of the bus and the protection of all passengers.

Daily Checklist

The bus should be inspected daily (prior to operation) to ensure safe operation and reliable service. The following is a minimum daily checklist. Additional checklist items may be added according to local operating conditions. Any items that fail to meet the checklist should be reported immediately to the

maintenance supervisor and repaired, as necessary, before placing bus in service.

For chassis concerns consult your chassis manual which is provided with the bus.

Exterior Checklist

- Inspect for any damage.
 - Clean windshield, driver's window, door glass, mirrors, and headlights.
 - Check all exterior compartment doors for being securely latched.
 - Make sure all bus identification is clear and clean.
 - Operate and check headlights, clearance lights, turn signals, and stop lamps.
 - Operate and inspect all warning devices, stop signs, warning lights, etc.
 - Check windshield washers and wipers.
-

Interior Checklist

People sometimes damage unattended buses.

- Aisles and stepwells must always be clear of objects.
 - Emergency exit handles must be in safe working condition.
 - Check all emergency exits for proper operation.
 - The "Emergency Exit" sign on an emergency door must be clearly visible.
 - You may lock some emergency roof hatches in a partly open position for fresh air. Do not leave them open as a regular practice. Keep in mind the bus' higher clearance while driving with them open.
 - Check all interior lights for operation.
 - Check seat backs and cushions for damage.
 - Inspect driver's seat belt for condition and operation.
 - Inspect windshield and side glass for cleanliness.
 - Check operation of all instruments when engine is started.
-
-

MINOTOUR

Final Check

- Adjust driver's seat and steering wheel.
- Start engine; look and listen for signs of trouble.
- Check all gauges and warning lights.
- Verify parking brake is applied and check operation of doors, emergency escape hatches and emergency exits.
- Check operation of interior lights and stepwell lights.
- Visually inspect bus, while engine is running, for fluid or exhaust leaks.
- Check operation of all exterior lights, safety equipment and signal devices.
- Check and adjust mirrors. Adjust the bus mirrors according to the following procedures before bus begins daily service:
- Check operation of the Vandalock Locking System option. (Refer to this information located in the "General Information" section of this manual.

Exterior Mirrors - Adjust mirrors so that the side of the bus just appears in the inboard portion of the mirror. This helps in judging the distance of objects from the bus.

Crossview Mirrors - Swivel the mirror head to give a clear view of area directly in front of the bus.

Interior Rearview Mirrors - Adjust mirror to provide a clear view of passenger area and roadway.

Convex Mirrors (Optional) - These mirrors provide a wider view of the adjacent lane. However, cars and other objects will appear smaller and further away than when viewed from a flat mirror. Use care when judging distances with this type of mirror.

Before Driving Off

- Secure all doors.
- Check operation of defroster and heater blowers, windshield wipers/washers and horn.
- Fasten seat belt.
- Check operation of service brake and parking brake.
- Visually check all gauges for normal operation readings.

Extended Vehicle Storage

Any time vehicle will be out of use over an extended period of time (60 days or more), the following steps should be taken to give it maximum protection:

1. Cover dash with opaque material.
2. Thoroughly clean vehicle. Touch up any painted surfaces that are scratched or chipped.
3. Disconnect batteries.
4. Consult your chassis manual.

Towing



Caution: Thomas Built Buses recommends that when a Minotour requires towing, that it be towed from the front whenever possible.

If the need arises for the unit to be towed from the rear, the towing operator should make sure the steer axle tires are rated high enough to support the unit weight when towing from the rear. It is also recommended that when towing from the rear the distance towed is less than 30 miles at 45 mph.

EMERGENCY EQUIPMENT

This section provides the operator with important information about the emergency equipment.

Safety equipment on the Thomas bus varies according to local, state, federal, and operator requirements.

It is important to carefully read and understand the following pages before operating the bus. A proper understanding of component location, function and operation is important to the competent operation of the bus and the protection of all passengers.

Emergency Door

An emergency exit door is located at the rear of the bus. Most doors have a locking capability in the open position to allow a clear exit from the bus. The opening hardware for the emergency exit door is protected to prevent accidental opening. Instructions for opening the emergency exit door are clearly displayed on the door face.

Opening of the emergency exit activates a warning buzzer in the operator's compartment.

⚠ Warning: The vehicle should not be driven if emergency exit buzzer is sounding.

Emergency Window Exits

The bus's emergency push-out windows also function as emergency exits. To open the windows in emergency situations, follow the instructions that are clearly displayed on the window.



⚠ Warning: The vehicle should not be driven if emergency exit buzzer is sounding.

MINOTOUR

Emergency Roof Escape Hatch (Optional)

The bus may contain an emergency roof escape hatch. The location of the hatch is subject to bus build specifications and according to Federal or State Regulations and variations. On buses equipped with an emergency roof escape hatch, the opening instructions are clearly displayed on the inside and outside of the hatch cover.

 **Caution: Vehicle should not be driven if roof hatch is open.**



First Aid Kit (Optional)

It is important that a first aid kit is maintained with the vehicle. If items or components are used, they should be replaced immediately. A need cannot be predicted; thus, be prepared for them at all times.



Body Fluid Clean-Up Kit (Optional)

The body fluid clean-up kit is used when any type of body fluid comes in contact with the bus. It is important that this kit be maintained with the vehicle at all times. If items are used, they should be replaced immediately.



Fire Extinguisher (Optional)

The fire extinguisher should be inspected monthly to verify that it contains sufficient charge. Observe gauge on fire extinguisher for current condition. Recharge fire extinguisher as necessary.

The chemical content of the fire extinguisher can be corrosive to any metal it contacts. Excess chemical from the fire extinguisher must be brushed or vacuumed off. Washing the chemical off will prevent severe corrosion problems.



Triangles (Optional)

Three reflectorized triangles complete with carrying case. Triangle unfolds and locks firmly in place. Standard mounting location left side floor under first seat.



Fusees (Flares) (Optional)

Three 30 minute fusees in a cylindrical container mounted with easy access by the driver. Operator should be familiar with the proper use of the fusees.



MINOTOUR

Seat Belt Cutter (Optional)

Seat belt cutting knife used for the purpose of cutting seat belt and wheelchair securement belts in emergency situations. Located with other safety equipment.



Fire Axe (Optional)

Fire axe is maintained with the bus for use in case of emergency. Usually located in driver's area or safety equipment compartment.



Wrecking Bar (Optional)

Wrecking bar is maintained with the bus for use in case of emergency. Usually located in driver's area or safety equipment compartment.



Overhead Storage Compartment

Located over windshield with quick release latch.
Designed for emergency equipment storage. Hinge
must be lubricated occasionally.



Outward Opening Door

There are two (2) adjustments for the standard outward opening entrance doors:

- Door opening adjustment
- Door closure adjustment

The opening and closing adjustments are factory set and should not require adjustment for many years under normal use; however, should it become necessary to readjust, follow these steps.

Manual Door Opening Adjustment

Open the doors fully and check the measurement across the opening. It should be 24". If this is incorrect, adjust as follows:



1. Remove the door control rod at the clevis on the front door leaf.
2. Open the access panel above the entrance door to expose the adjusting rod.
3. Remove the cotter pin located in the curved end of the adjustment rod connected to the rear door leaf.
4. Loosen adjustment rod jam nut and turn rod clockwise to increase door opening, or turn counterclockwise to decrease opening.
5. Do not exceed the door opening. This also controls the sequence of the front and rear doors closing. The rear door leaf must come in first allowing the front door leaf to contact and seal the door and stepwell opening.
6. Reinstall linkage and tighten all jam nuts.

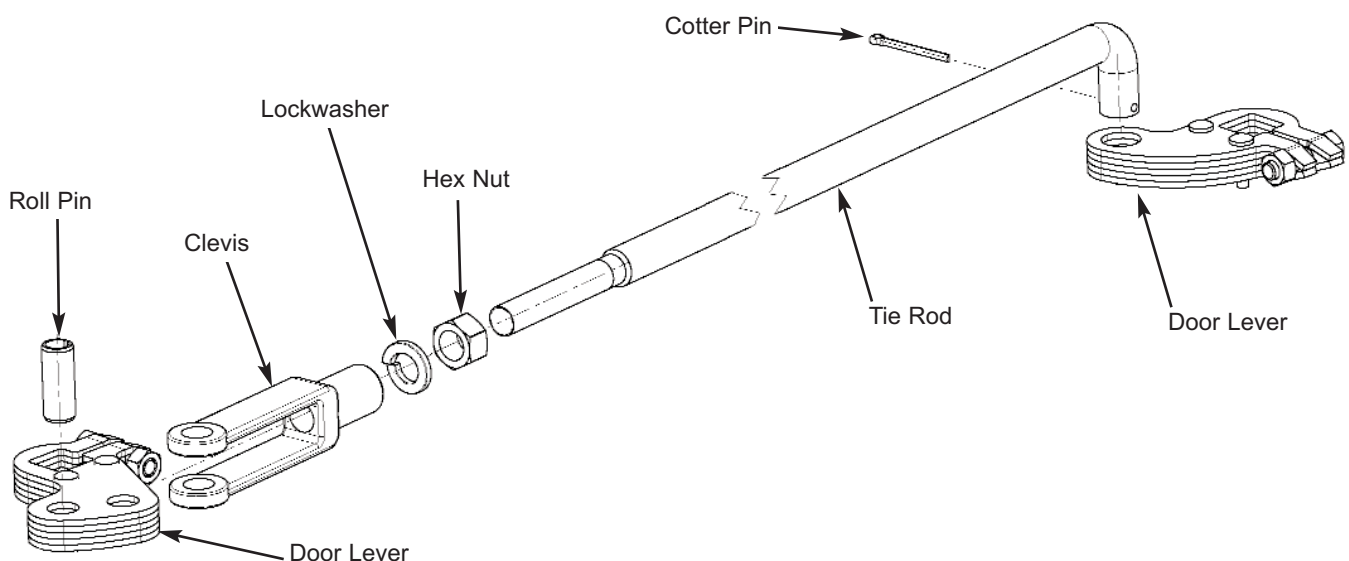

MINOTOUR

Manual Door Opening Adjustment *(continued)*

7. Check door for proper opening and closing. Forward leaf overlaps the rearward leaf.



Manual Door Closure Adjustment

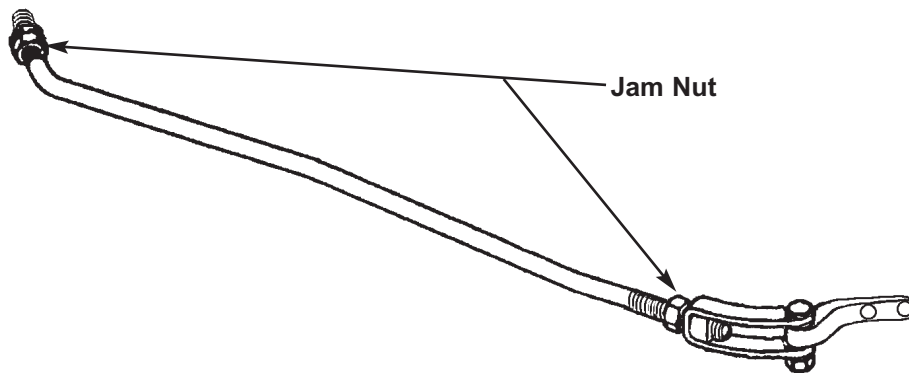

1. Loosen jam nuts at both ends of control rod.
2. Remove one end by removing clevis bolt nut and/or bolt depending on end taken loose.
3. Adjust by turning the control rod counterclockwise to lengthen and clockwise to shorten.
4. Check operation and tighten jam nuts.

Other Door Maintenance Items:

The door control mounting bracket located at the approximate center of the cowl should be tightened in the first thirty (30) days and at least every six (6) months thereafter.

The door hinge fasteners should be tightened periodically to assure proper door operation.

It is very important that drain holes in the bottom of outward opening doors be probed and cleaned every thirty (30) days. Use small screwdriver for a cleaning probe.

Apply a graphite base oil to all door controls and hinges every thirty (30) days. Remove all excess oil to avoid accumulation of foreign elements.

⚠ Caution: Care should be taken not to adjust this rod so tight that distortion of the door occurs.

Electric Door Adjustment

Open the doors fully and check the measurement across the opening. It should be 24". If this is incorrect, adjust as follows:

1. Remove the cotter pin and the clevis pin from the front door leaf. Move the rod end of the actuator to the side.
2. Loosen the jam nut on the tie rod / clevis assembly and start with a center-to-center length of 25.75"

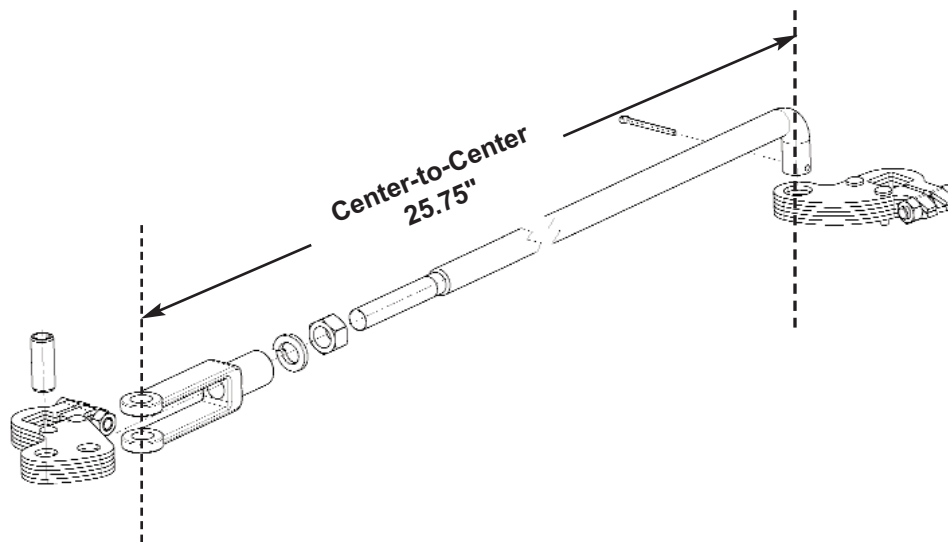

3. Install the tie rod clevis and pin. Pull the doors closed by the rear door. With the rear door held in the CLOSED position, the front door should be open by 1/2".
4. If the opening is too large or too small, remove the clevis pin and adjust the length of the tie rod. Spin the clevis one or two turns longer to narrow the opening. One or two turns shorter will increase the opening between the doors. When adjusted, tighten the tie rod jam nut.
5. Only hand tighten the jam nut for the rod end on the actuator. Adjust the rod end so that 1/2" of threads are exposed.
6. Install the clevis pin with the tie rod and actuator in position. Test door operation. Do not exceed the 24" door opening. The actuator rod may have to be turned out (longer) to limit the door travel. When adjusted, tighten jam nut and install the cotter pin.

NOTE: The electric actuator force is preset by the manufacturer and is not adjustable. It stops at the end stops of a stroke or when the pressure exceeds its amp current limit.

See illustration on next page.



Rear Emergency Door

Emergency door located on the rear of the bus. The opening hardware for the emergency door is protected to prevent accidental opening. Instructions for opening the emergency door are clearly displayed on the door face.

This door should be opened daily to ensure that it will open freely when it is needed. Grease hinge as necessary. You should also examine the door seal and ensure that it is not damaged or obstructed with any foreign material.

Opening the rear emergency door activates a warning buzzer in the operator's compartment.

⚠ Warning: The vehicle should not be driven if emergency exit buzzer is sounding.



3 Point Locks Inside Door (Optional)

Lock for rear or side emergency door; provides positive lock at top, bottom, and center.

Check operation at maintenance intervals.



MINOTOUR

Vandalock Locking System(Optional)

Manual locking system for rear door. Equipped with interlock device which **will not** allow ignition system to operate while rear door is locked.

The vandalock utilizes a barrel bolt lock assembly to secure the rear emergency door. It includes a buzzer, mounted on rear emergency door vandalock, to notify driver when rear emergency door is locked and vehicle cannot be started.



Windows - Split Sash, Removal and Installation



The sash is installed in the window opening and is securely anchored on both sides to the one piece bow frames with four (4) clips, two (2) on either side of the window.

1. Remove four (4) screws, two on each side of the window, and remove the clips.
2. Pull the top of the sash to the interior of the bus body.
3. Lift sash assembly out of window opening.
4. Disassembly of the sash for glass replacement will be covered in the next section "Glass Replacement".
5. **Prior to reinstalling sash in opening, seal all corners of the window opening.** This will assist in keeping moisture out of the body sidewalls. Use silicone, part # TBB 01013370 or equivalent.
6. Reassemble by reversing Steps 1-3.
7. Reseal sash, inside and outside using silicone, part # TBB 01013370 or equivalent. **Be sure to reseal all corners.** This will ensure that moisture does not enter inside of the body.

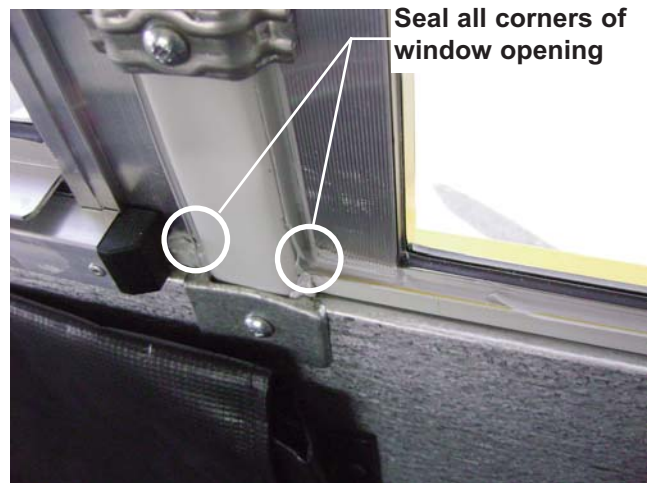

Glass Replacement

The glass used in your bus must meet certain Federal Motor Vehicle Safety Standards, such as FMVSS-217. Therefore, whenever a glass is broken or must be replaced, it should be replaced with identical glass. The following instructions are for replacing glass in split sash:



Warning: Always wear heavy gloves and eye protection when handling glass to minimize the risk of injury.

1. Remove sash as per section "Sash Removal".
- 2a. To replace the lower stationary glass, loosen the center screw on each end of the center rail. Remove the screw on each end of the lower rail.
 - b. Remove lower rail and slide glass out.
- 3a. To replace the upper sliding section, glass, stand window on it's side and remove three (3) screws from the sidemember.
 - b. Remove the sidemember.
 - c. Remove the screw on each end of the lower rail of the sliding section and slide glass out.
4. Check the glazing rubber. If the seal is damaged or has deteriorated, replace the one-piece rubber seal available from your Thomas Dealer.
5. Check the new glass to be installed. Sharp corners will cut the glazing rubber seal and lead to glass breakage due to glass contacting metal. The corners should be ground to a smooth radius of 1/8".
6. Reverse Steps 1-3 to reassemble sash. Be careful not to twist or cut the gasket as you slide it into place.

Windows - Split Sash, Pushout - Glass Replacement **IMPORTANT**

The glass used in your bus must meet certain Federal Motor Vehicles Safety Standards, such as FMVSS-217. Therefore, whenever a glass is broken or must be replaced, it should be replaced with identical glass. The following instructions are for replacing glass in split sash.

It is suggested that you remove only one section of glass at a time. It is more difficult to replace if both are removed.

1. Open the sash approximately 15 to 20 degrees and secure in that position. A rubber tie down works well in holding the sash out.
2. Remove the screws in the bottom rail and remove the stationary lower rail and glass.
3. Remove the screws in the center rail and remove the center rail.
4. Release both window latches and lower the sliding glass and frame out the bottom of the rails.
5. Check the glazing rubber. If it is damaged or has deteriorated, replace it with the one-piece rubber seal available from your Thomas Dealer.
6. Check the new glass to be installed. Sharp corners will cut the glazing rubber seal and lead to glass breakage due to glass contacting metal. The corners should be ground to a smooth radius of 1/8".
7. Reverse procedure 1-4 to reassemble sash.

Stationary Glass

This section applies to entrance doors, side emergency doors, and rear stationary windows.

Warning: Always wear heavy gloves and eye protection when handling glass to minimize the risk of injury.

To remove the glass for replacement or structural repair, follow the steps listed below:

1. Apply pressure against the glass from the outside of the body. Start at one top corner, work your way down and around outer edge of rubber seal pushing glass and seal together off the metal flange. Remove the glass and rubber seal intact.

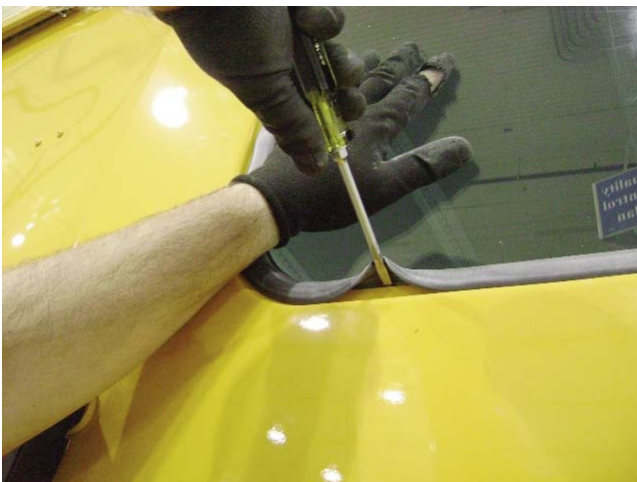

2. Remove rubber seal from glass and inspect seal for cuts and deterioration. If any are found, replace rubber seal to avoid future leaks and glass breakage.
3. Inspect metal flange for burrs and sharp edges that could cut rubber seal. Inspect flange for rust and deterioration. Repair and repaint before reinstalling glass and rubber seal, if necessary.
4. Inspect new or replacement glass and install rubber seal around outer edge. **Note: All glass used by Thomas meets FMVSS 205 requirements. Use of OEM glass is recommended when replacing any glass on the bus.**

5. Apply a soapy solution, silicone, or rubber lubricant to the outside diameter of the seal. This will aid in installation of the glass and seal.



6. Using a nylon cord approximately 2' longer than the total circumference of the rubber seal, wrap the cord around the seal and glass. Rest the assembly on the bottom flange of the window opening, from the inside of the bus.
7. Pull the cord slowly from the outside of bus while an assistant applies light pressure to the glass from inside the bus. Work rubber seal onto the metal flange.
8. Apply even pressure to the edge of the rubber seal from inside the bus to seat the seal and position the assembly on the metal flange. This will ensure a proper seal.



MINOTOUR

Seats and Barriers

All seats and barriers used in the manufacture of school bus bodies must meet many Federal and State requirements. One requirement commonly overlooked is the seat back foam for impact energy absorption. This is directed primarily where the head and knees will strike the seat back in the event of an accident.

Styrofoam is used in this critical area where its impact resistance is determined by its density and thickness. The seat back is designed so that the styrofoam will crush or collapse under a predetermined force. This absorbs much of the force generated by the child's head or knees when he is thrown into the seat.

Once this occurs, the styrofoam is damaged and the seat back would not serve the purpose for which it was designed. Unless you removed the upholstery, you would not know whether the foam should be replaced or not.

There are suppliers of seat backs, other than the manufacturer's dealer, that are serving the after-market. The maintenance director should check these companies for complete compliance with the Federal standards prior to purchase and installation of this material.

To remove seat backs for inspection and/or replacement of the cover or foam, the following should be performed:

1. Pull the staples from the vinyl fabric under the plate.
2. Slide the cover and foam envelope up and off the frame.
3. Inspect and replace as necessary.
4. Reverse procedures 1 and 2 to reinstall.

There are many types of tape and vinyl repair materials on the after-market for minor cuts and seat cover repair. Torn seams in the cushion or back covers can be easily repaired by removing the covers, re-sewing the seams, and reinstalling.

Seat cleaning and care recommendations are from the Chemical Fabrics and Film Association.

"Chemical Fabrics and Film are made to withstand scuffing, cracking, peeling and hard use. They will come up fresh and sparkling after a mild soap-and-water bath and a clear water rinse. However, certain stains, if allowed to remain, may become set, making removal more difficult. It is important to remove these stains as soon as possible."

Day to Day Soil - Most stains can be removed with a neutral soap, warm water and, if necessary, a good, stiff brush. Fabric should be thoroughly rinsed with clear water, then blotted dry.

Paint or Enamel - Remove immediately with a sponge or cloth dampened with turpentine or kerosene. Rinse.

Nail Polish or Lacquer - Remove immediately for best results. Pick up as much as possible with dry cloth, taking care not to spread stain. Go over quickly and lightly with non-flammable cleaning fluid. Rinse thoroughly.

Tar, Asphalt - Remove immediately. Lengthy contact will cause a permanent stain. Using cloth dampened with kerosene, rub gently from outside edge of stain to center. This will prevent stain from spreading. Rinse.

Chewing Gum, Car Grease, Shoe Polish - Scrape off as much as possible (chewing gum will come off more easily if rubbed with ice cube) and go over lightly with cleaning fluid to remove remainder. No time should be lost in removing shoe polish as it contains dye which can cause permanent staining. Rinse thoroughly.

(Continued on next page.)

GENERAL INFORMATION

Seats and Barriers *(continued)*

Ball Point Ink - Remove immediately to avoid permanent staining. Use cloth dampened with alcohol. Rinse thoroughly.

Note: Powdered abrasives, steel wool, and strong cleaning preparations are not recommended. They usually cause dulling, especially of glossy finishes.

Wax should only be used on Chemical Coated Fabrics and Film if manufacturer recommends its use. Many waxes contain dyes, and dyes will stain.

The main thing to remember is to use good judgement when choosing any cleaning substance other than soap and water.

Restraining Belts

Restraining belts are only available on seats specifically designed for their use.



Warning: Seat belts must only be used on seat assemblies designed for their use.

All should be checked for proper operation daily and fasteners should be checked monthly.

To fasten the belt, pull the belt across the occupant and insert the tongue into the buckle until it clicks. Pull to make sure it is latched, snug the belt by pulling slack out.

Press the button on the buckle to release.

Application - Hold buckle in one hand and pull connector belt across pelvic region (hip bone).



Vendor Seats

If your bus is equipped with passenger seats other than Thomas, you can contact them direct for information on care and maintenance. Below is a list of these manufacturers.

- American Seating Company
401 American Seating Center
Grand Rapid, MI 49504
(616) 732-6600
- Freedman Seating Company
4043 N. Ravenswood
Chicago, IL 60613
(773) 929-6100
- The C. E. White Company
P. O. Box 308
New Washington, OH 44854
(419) 492-2157
- Transportation Seating
P. O. Box 595
Montezuma, GA 31063
(616) 732-6600
- Syntec, Inc.
200 Swathmore Ave.
High Point, NC 27263
(336) 861-9023
- IMMI
18881 US 31 N.
Westfield, IN 46074
(800)-586-7839

MINOTOUR

IMMI Safeguard 2 Integrated Lap & Shoulder Seat Belt with Integrated Child Seat and Without ISO Latch

The IMMI lap and shoulder belt seat is certified for School bus use; complies with FMVSS and CMVSS 210, 222.

The adjustable shoulder belt is designed to maximize comfort, and fits children of various sizes. It offers compartmentalization protection for unbelted children and lap / shoulder belt protection for belted children.

The flexible built-in child seat offers 5-point protection for children weighing 22 - 65 lbs. Maximum number of children per row is four (4).

For more information refer to the Guideline for the Safe Transportation of Pre-school Age Children in School Buses: This Guideline, released by NHTSA in February 1999, was developed to assist school and other transportation managers in developing and implementing policies and procedures for the transportation of pre-school age children in school buses. The document is available on NHTSA's website:

<http://www.nhtsa.dot.gov/people/outreach/media/catalog/Index.cfm>.

⚠ Caution: Complete bus must be seated using IMMI seats.

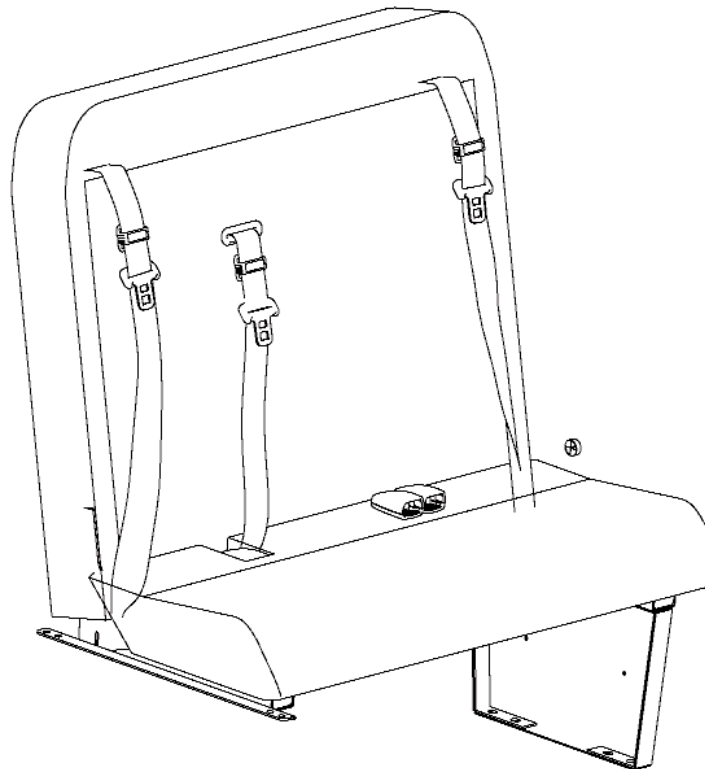

Isometric view for reference only

Track Seating - General Installation and Removal Guidelines

Removal and installation of track seating in school buses is the responsibility of the school bus operator and maintenance staff; these guidelines are provided by Thomas Built Buses to assist owners and operators to help insure safe and compliant seating arrangements. Because the number of variations and combinations of removable seating in a school bus is almost limitless, these recommendations and guidelines are not intended to cover every possible configuration that might be required in service. If there is any doubt as to the safety and/or compliance of a particular seating configuration, please ask TBB to help at 336 841 5911.

1. Thomas Built Buses (TBB) recommends that units be ordered with maximum seating capacity installed at the factory to ensure that gross axle weight ratings (GAWR) and gross vehicle weight ratings (GVWR) are not exceeded. If seating is added to a school bus that was not ordered or delivered on the bus as configured by Thomas Built Buses, care should be taken to ensure that axle weight ratings and gross vehicle weight ratings are not exceeded. Actual weight of the unit with full fluid capacities (full of fuel) with 120 lb. per seating position for all seats on the vehicle and 150 lb. for driver and each wheelchair position should not be greater than the GAWR or GVWR printed on the vehicle federal data label. For capacity calculations, the full passenger load should be added to the rear axle of the vehicle. If there is any doubt as to the capacity of the vehicle and allowable weight loading, please contact the Thomas Built Buses, Inc. Engineering Services staff for help at 336 841 5911.
2. All TBB tracked school bus seat options are designed for forward facing orientation on the vehicle.
3. All wheelchairs should be secured in the forward facing orientation on the vehicle and secured per the wheelchair restraint manufacturer's instructions.
4. All knee room measurements should be referenced at the center of the seat and at the seat reference point height which is typically .25" above the seat cushion's highest point.

MINOTOUR

Track Seating - General Installation and Removal Guidelines

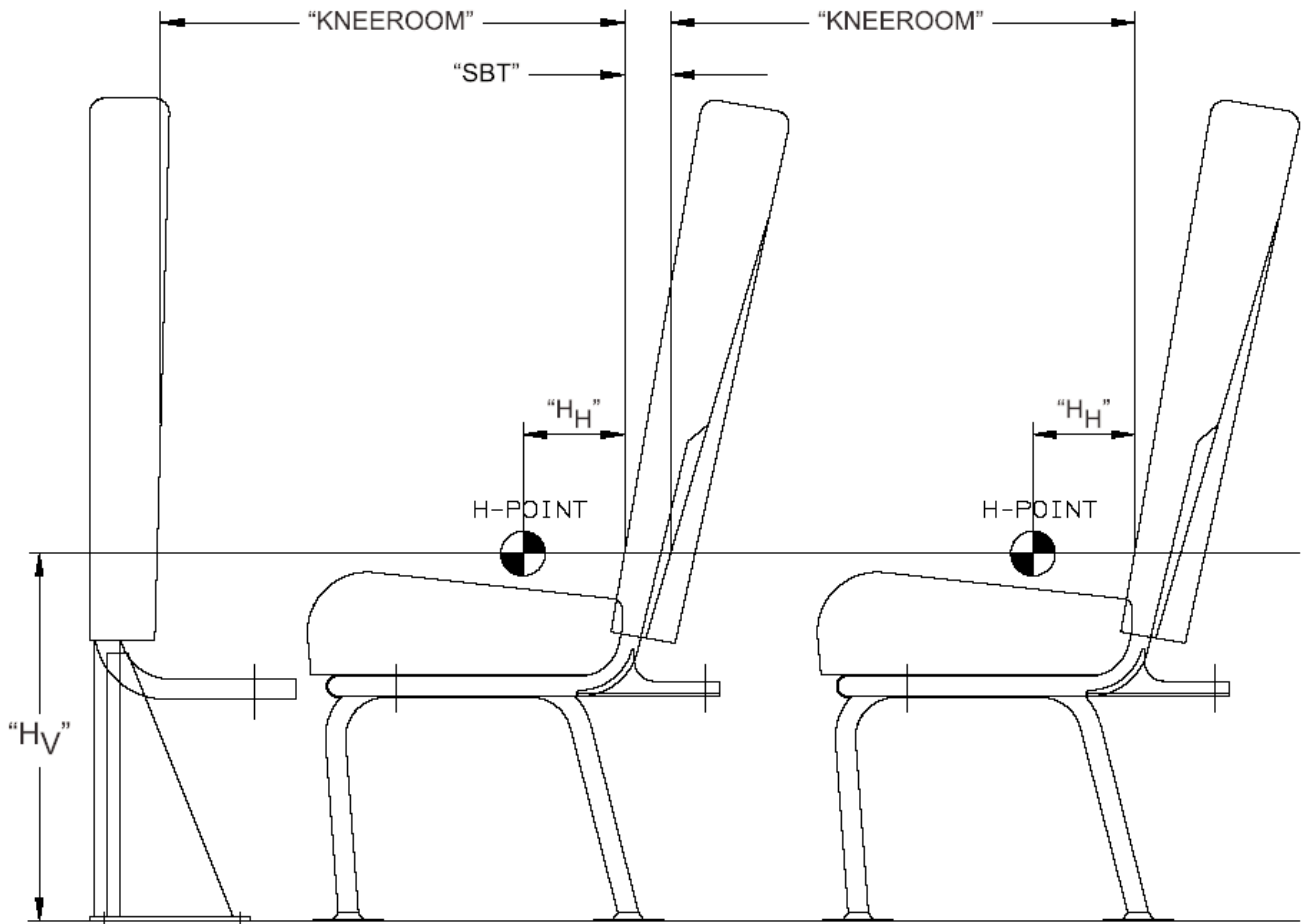

H_H = H-POINT HORIZONTAL

H_V = H-POINT VERTICAL

SBT = SEAT BACK THICKNESS

H-POINT = HIP POINT

(Continued on next page)

Track Seating - General Installation and Removal Guidelines *(continued)*

5. School bus seating is designed to accommodate student encapsulation for primary crash protection. Encapsulation uses the seat backs and barriers as a passive restraint system to absorb kinetic energy in a crash situation and protect passengers. Seat spacing is critical to passive encapsulation to protect passengers in the event of vehicle impacts. It is essential that removable seats be installed to maintain spacing that ensures safe configurations. The minimum seat spacing is limited to protect occupants from rear end collisions and ensures that there is adequate room for rearward seat back deflection in the knee area, and to facilitate ingress and exit from the seat row. The

maximum seat spacing is limited to protect occupants from front end collisions and ensures that there is sufficient forward deflection to absorb collision energy. TBB recommends that seats be marked or mapped when removed from a school bus and reinstalled exactly where removed. When this is not possible and to support the numerous configurations often allowed by removable seat options, care should be taken to make sure seats are within minimum and maximum spacing, as shown below.

Track seats	H _H Inch	H _V Inch	SBT	*Min Knee room Inch	Max Knee room = 24"+H _H Inch
SynTec Standard	5.3	18.75	1.4	24	29.3
**SynTec ISO	5.3	18.75	1.4	26.8	29.3
IMMI Gen II	5.5	19	5.5	24	29.5
**IMMI Gen II ISO	5.5	19	5.5	26.8	29.5
IMMI Gen II ICS	5.5	19	5.5	24	29.5
**IMMI Gen II ISO/ICS	5.5	19	5.5	26.8	29.5
IMMI SSA	5.43	19	2.25	24	29.43
**IMMI SSA ISO	5.43	19	2.25	26.8	29.43
IMMI SSA ICS	5.43	19	3.38	24	29.43
**IMMI SSA ISO/ICS	5.43	19	3.38	26.8	29.43

*Each seat has a unique absolute minimum knee room spacing per FMVSS 222. Generally this minimum is less than recommended. Most states require a minimum knee room of 24". It is also recommended by Thomas Built Buses that a minimum knee room of 24" be maintained. If you require a knee room of less than 24", contact Thomas Built Buses to get the seats absolute minimum spacing.

**All ISO seats should have a minimum knee room of 26.8"

Notes for measuring:

1. Track seats must be spaced in 1" increments. Measurements should be rounded up for minimum knee room and rounded down for maximum knee room.
2. Check your state and local guidelines for how to measure the knee room.
3. Seat back thickness (SBT) is measured at H-point when all air is compressed from the seat back
4. Seat spacing is the Seat Back Thickness plus knee room.

6. All seats in a school bus should have another seat or a barrier installed immediately in front above minimum seat spacing and below maximum seat spacing. In no circumstances should seats be removed from the middle of a seat row. In general, seats should be removed from the rear of the bus in school buses with a rear lift door position and from the front of the bus in vehicles configured with a front lift door location. When seats are removed from the front of a seat row, a track mounted barrier should be moved rearward to allow above the minimum knee room and above the maximum knee room between the barrier and the first seat. Seat rows should be removed to allow at least a 46" clear space for the addition of a wheelchair passenger.
7. Track options that allow for different seat widths in the same seat row should always have the wider seats located in front of narrower seats. Never install a narrow seat in front of a wider seat.
8. Care should be used to install seating to allow clear access to emergency exits, especially push out window exits and emergency exit doors. Seat backs must allow for a 2" clearance for emergency exit handle access and the seat back should not obstruct the clear opening of the emergency exit such that

an ellipsoid with major axis of 50 centimeters and minor axis of 33 centimeters, keeping a major axis horizontal at all times can pass through the opening without contact with the seat back.



Ellipsoid gage passing in behind of seat back



Ellipsoid gage passing in front of seat back



Ellipsoid gage passing above seat back

(Continued on next page)

Track Seating - General Installation and Removal Guidelines *(continued)*

9. Wheelchair anchorages should allow passage of the ellipsoid in front of the torso or behind the shoulder belt attachment as shown below.

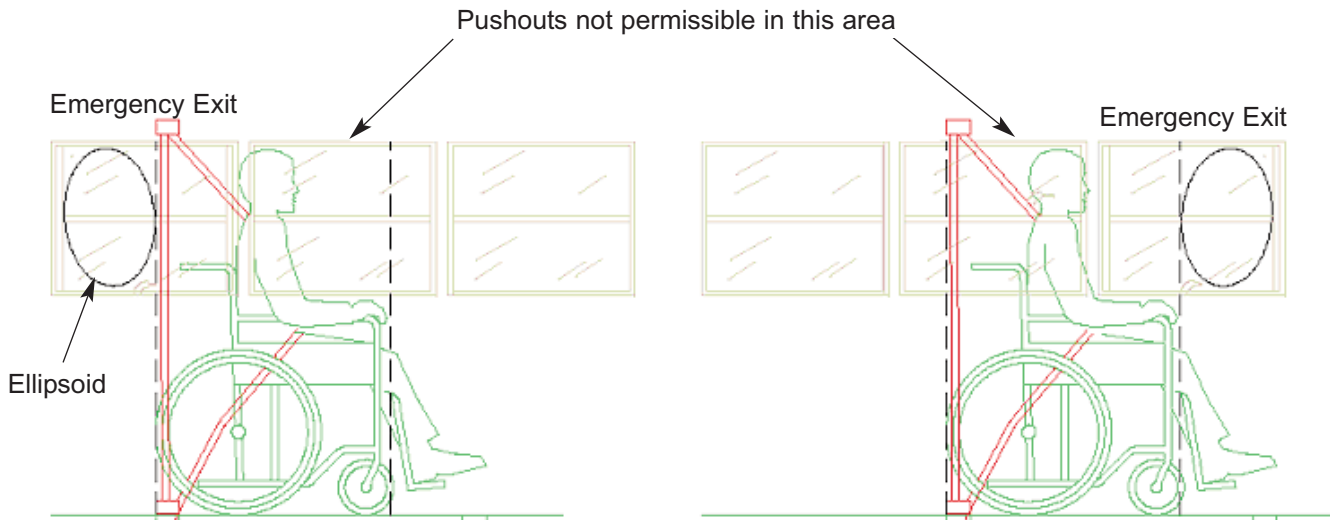

10. Removable barriers and seats should allow for a 12" clear aisle to emergency exit doors without exceeding maximum seat spacing. This is typically achieved by the position of a

barrier immediately at the door opening and far enough behind the forward seat to allow a 12" clear aisle for side emergency doors.

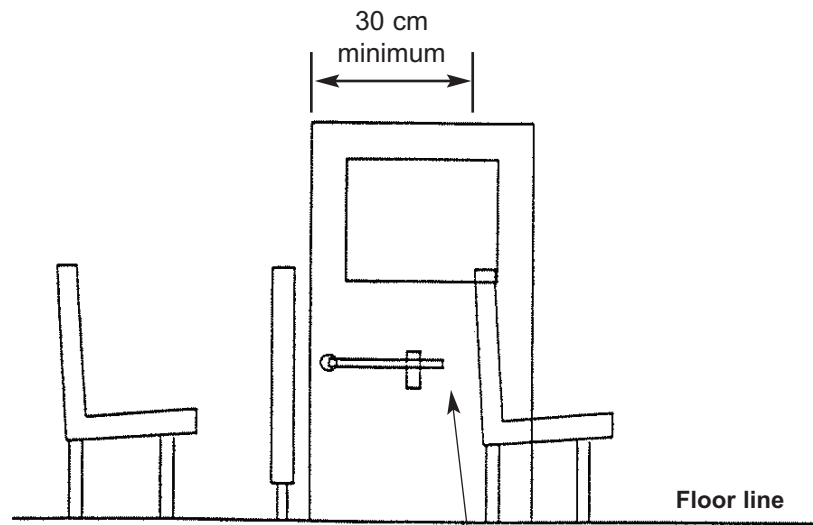

No seat or barrier may extend past door opening

No obstruction of door latch mechanism

Minimum Side Emergency Exit Clearance Specifications

MINOTOUR

11. Wheelchair anchorages should be kept well away from the exit aisle to side emergency exit doors. No anchorages are allowed within 12" of the centerline of the exit aisle.

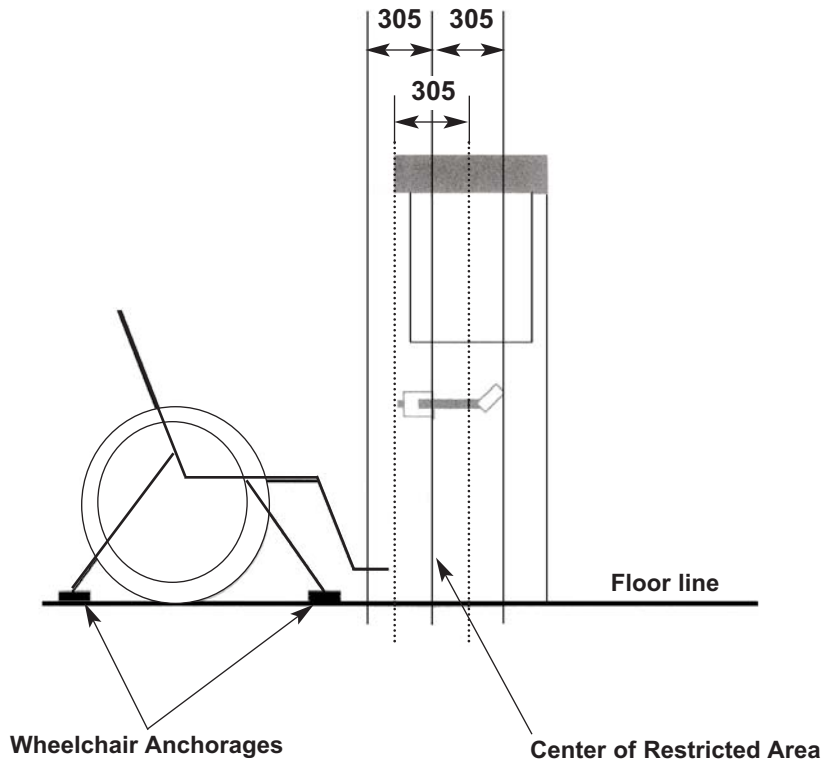

Side Emergency Exit - No Wheelchair Anchorages within the indicated region

Track Seating - General Installation and Removal Guidelines *(continued)*

12. The rear exit door deserves special attention in a school bus. Fully tracked units with removable seats adjacent to the rear exit door must allow enough clear area in the door opening to accommodate a 305 mm deep x 610 mm wide, x 1143 mm high volume for vehicles with a GVWR greater than 4336 kg (10,000 lb). For vehicles with a GVWR of less

than 45336 kg, the opening should accommodate a volume of 152 mm deep x 558 mm wide x 1143 mm high. These dimensions are measured from the top of floor to the outside of the rear bus wall at floor level with the rear emergency door open.

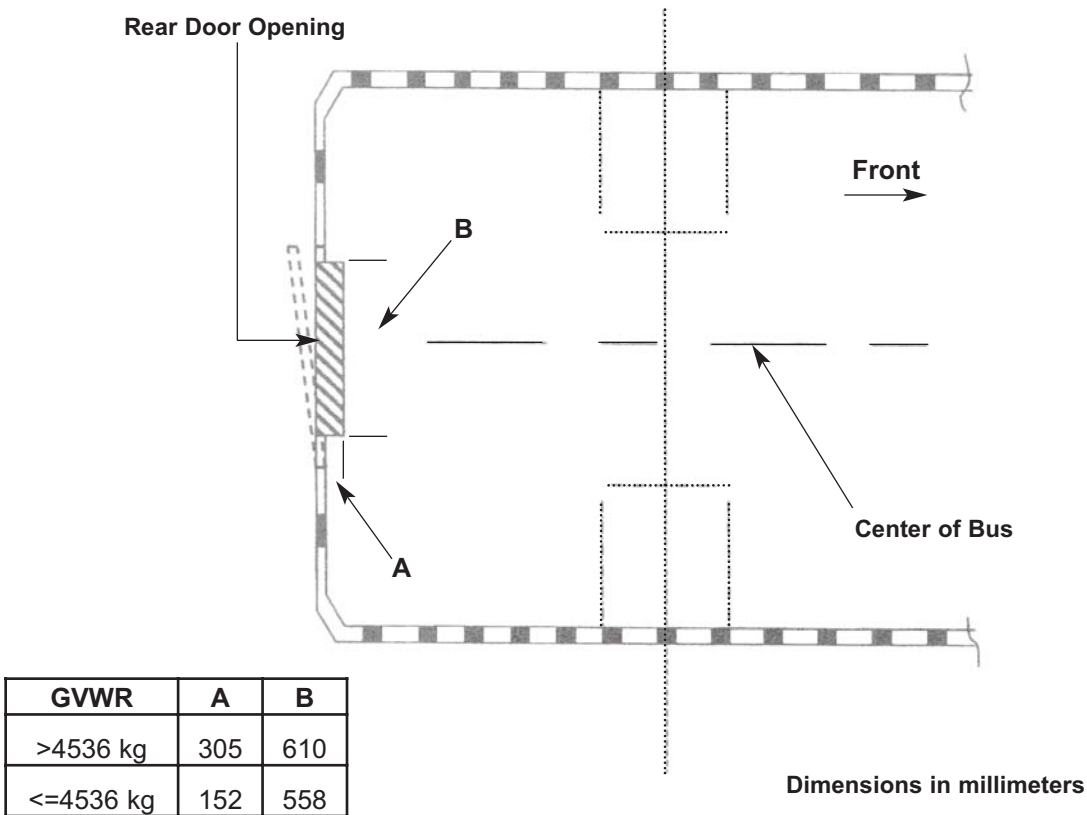

Rear Door Emergency Exit - No Wheelchair Anchorages within the shaded region

13. Wheelchair anchorages should be excluded from this area.

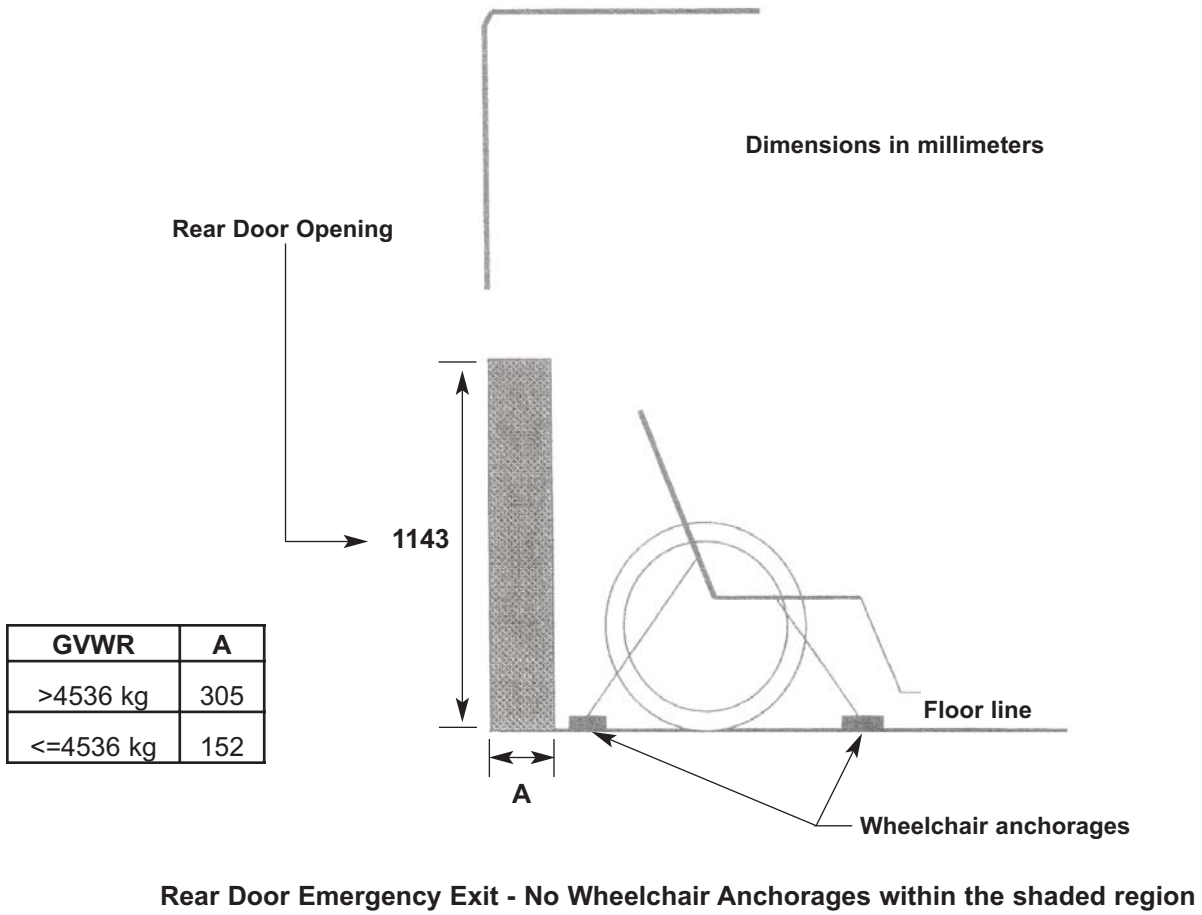

Track Seating - General Installation and Removal Guidelines *(continued)*

14. Different seat types and/or styles have different installation criteria. Care should be taken to identify the specific seat style and type per the seat installation section of this manual.
15. Seats equipped with ISO Latch infant carrier attachment options should be located in the first row of a school bus. If more than two seats have been ISO Latch equipped, they may be located anywhere behind the first rows and the rear most row on the vehicle.
16. Tests have shown infant carriers with the infant secured rearward facing is the safest way to transport infants.
17. ISO Latch equipped tracked seats (infant carrier capable) should be spaced at 27" minimum regardless of seat type and minimum spacing allowed by the seat type chart. This minimum spacing is to protect the infant from contacting the seat back or barrier due to infant carrier belt stretch in a frontal collision.
18. If one seat is installed in a TBB product with seat belt option, all seats in the vehicle should be equipped with seat belts.
19. Again, Thomas Built Buses is dedicated to helping our customers operate our products in the safest way possible and is ready to assist them in any way we can. If there is any doubt as to the safety and/or compliance of a particular seating configuration or track seat removal/install, please ask a TBB expert to help at 336 841 5911.

MINOTOUR

Door Impact Zone

Note: Refer to FMVSS 217 for additional Information.

School buses with a GVWR of more than 10,000 pounds: In the case of a rear emergency exit door, an opening large enough to permit unobstructed passage of a rectangular parallelepiped 114 centimeters high, 61 centimeters wide, and 30 centimeters deep, keeping the 114 centimeter dimension vertical, the 61 centimeter dimension parallel to the opening, and the lower surface in contact with the floor of the bus at all times.

School buses with a GVWR of 10,000 pounds or less: In the case of a rear emergency exit door, the rectangular parallelepiped dimensions shall be 45 inches high, 22 inches wide, and six inches deep.

Disregarding the GVWR of School buses: In case of a side emergency exit door, an opening of at least 114 centimeters high and 61 centimeters wide is required.

No portion of a seat or a restraining barrier shall be installed within the area bounded by the opening of a side emergency exit door, a vertical transverse plane tangent to the rearward edge of the door opening frame, a vertical transverse plane parallel to that plane at a distance of 30 centimeters forward of that plane, and a longitudinal vertical plane passing through the longitudinal centerline of the bus.

(continued on next page)

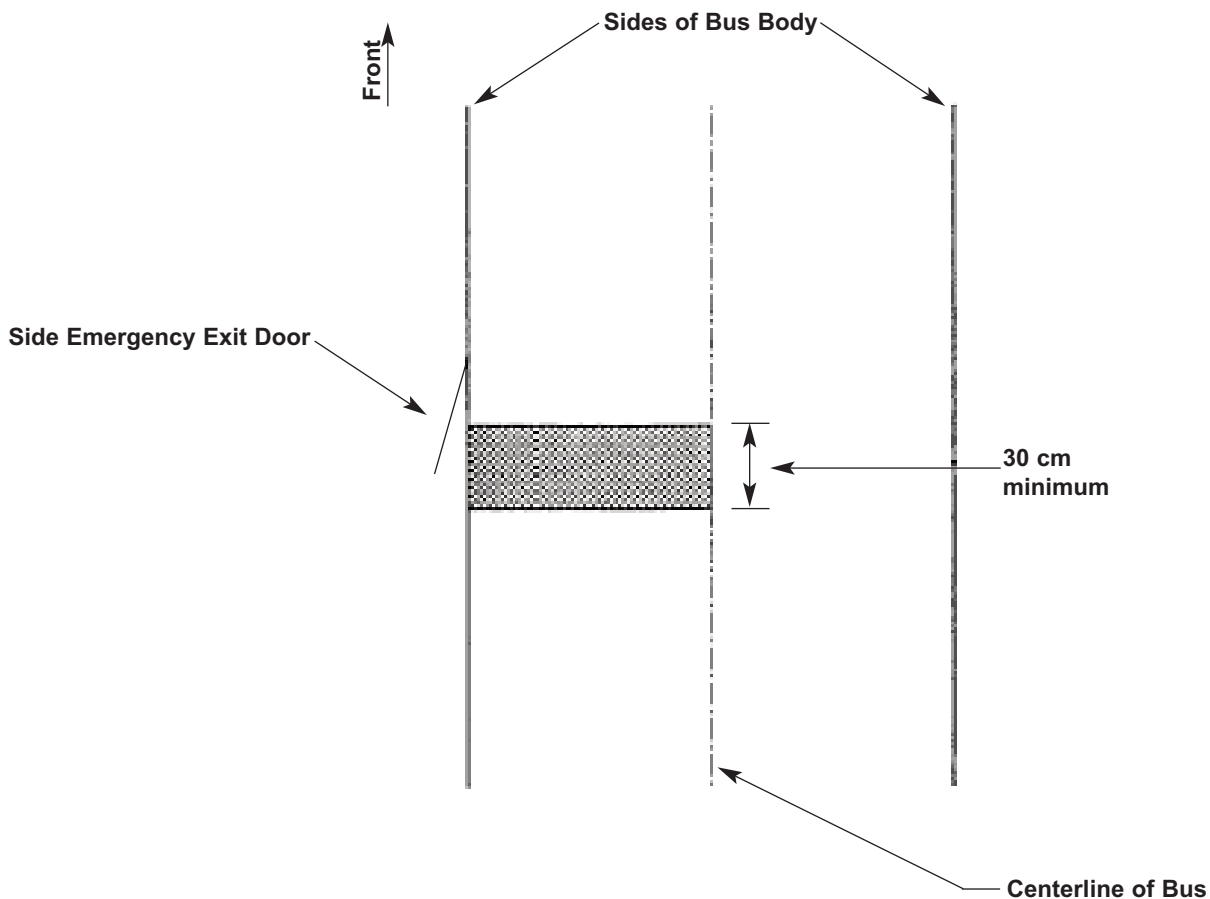

Minimum Side Emergency Exit Clearance Specifications (Plan View)

Door Impact Zone (*continued*)

However, a seat bottom may be located within the area as described if the seat bottom pivots and automatically assumes and retains a vertical position when not in use, so that no portion of the seat bottom is within the area as described above. When the seat bottom is vertical, see below.

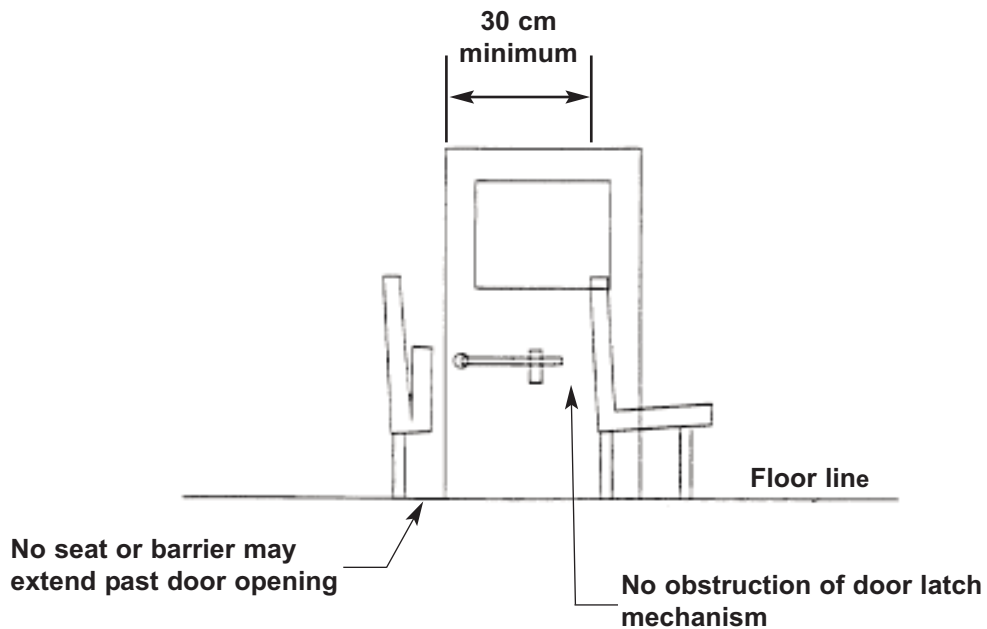

Minimum Side Emergency Exit Flip-Up Seat Clearance Specifications

MINOTOUR

No portion of a seat or restraining barrier located forward of the area described above and between the door opening and a longitudinal vertical plane passing through the longitudinal centerline of the bus shall extend rearward of a vertical transverse plane tangent to the forward most portion of a latch mechanism on the door.

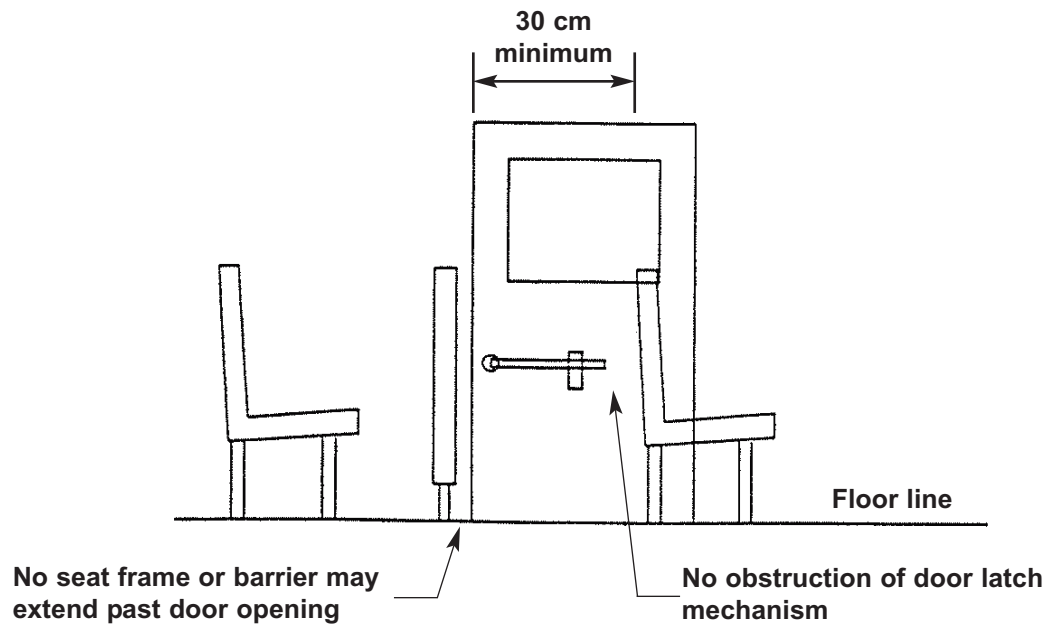

Minimum Side Emergency Exit Clearance Specifications

Definitions

Compartmentalization: The concept of protecting each child within the passenger compartment of a school bus with a padded barrier that would prevent injury.

H point: Also known as the SRP or Seating Reference Point. It is the calculated location of a point that would be the hip pivot point of a test dummy designed for this purpose. This point will vary between seat design and manufacturers.

Knee room: The distance measured from the front of the seat back to the rear side of the seat back in front, passing through the H point. Also the same as seat spacing minus the seat back thickness.

Seat spacing: The distance measured from the same point on two adjacent seats.

Track seating: Seats that are installed on a track in the floor to allow for flexibility in mounting locations.

FMVSS: Federal Motor Vehicle Safety Standards.

CMVSS: Canadian Motor Vehicle Safety Standards.

ICS: Integrated Child Seat

This section of the manual will provide important information for installing and reinstalling track seats. It is important that each seat be properly installed to comply with state and federal law. Each step is important to follow the laws set forth to keep each passenger safe. By following the outline of this section you will be better able to identify your seat, learn seat installation requirements, and determine proper seat spacing for each seat. It is always recommended that you only re-install the seats that were originally installed in the vehicle and that they be installed in the same location as they were removed. If you are unsure of any step in installing track seating, please contact Thomas Built Buses.

MINOTOUR

Track Seat Identification

When installing a track mounted seat, it is important that you know what seat you are installing. You must be able to identify each seat being installed to maintain the proper seat spacing. A seat can be identified by following these three steps:

1. Determine the make of the seat.
2. Determine the type of seat
3. Determine what options, if any, are on the seat

1. Determine the make of the seat:

Track seating is offered in two makes, IMMI and SynTec. The easiest way to distinguish between the two is the distinct outer perimeters.



Example of IMMI Seat

All IMMI seats will have a similar appearance. The IMMI seat has two different variations, the Gen II and SSA. The difference between the Gen II and the SSA are the seat backs. The SSA has a concave back and the Gen II has a straight back.

(continued on next page)



IMMI SSA Seat (concave back)



IMMI Gen II (straight back)

Track Seat Identification (*continued*)

The SynTec seat can be seen below. All SynTec seats will be similar in shape. Another difference between the two is the SynTec frame. All SynTec seats will be constructed with round tubing, unlike the IMMI seats.



Example of SynTec Seat

2. Determine the type of seat:

To identify the seat types you must measure the length of the seat cushion. Listed below are the measurements of each type of seat. The seat cushion is measured across the width of the cushion. The following picture shows how to measure the seat cushion. Both the SynTec and IMMI seat can be identified using the same method.

IMMI track seats are offered in 5 types: 30", 36", 39", FLEX, and 45".

SynTec track seats are offered in 3 types: 30", 36", and 39".

30" seat will have an approximate seat cushion width of 30".

36" seat will have an approximate seat cushion width of 36".

39" seat will have an approximate seat cushion width of 39". The 39" seat will not have three lap and

shoulder belts.

FLEX seat will have an approximate seat cushion width of 39". The FLEX seat will also have three lap and shoulder belts.

45" seat will have an approximate seat cushion width of 45".



Measuring Cushion Width

MINOTOUR

3. Determine what options, if any, are on the seat:

Review each option in the manual to determine what options, if any, are on the seat. It is important that you determine what options are present to install the seat properly. The IMMI track seat is offered with ISO latch, ICS, lap and shoulder belts, and lap belts. Each seat can have one, none, or a combination of these options. The SynTec track seat is offered in low back, high back, ISO latch, and lap belts. The following pictures show each individual option with each make of seat. If you are unsure or can not find the option in this manual, please contact Thomas Built Bus for assistance.



IMMI ICS (number of ICS may vary)



**IMMI Lap/Shoulder Belt
(number of belts may vary)**

(continues on next page)

Track Seat Identification *(continued)*



IMMI Lap Belt (number of belts may vary)



IMMI FLEX Seat



SynTec Lap Belt (number of belts may vary)

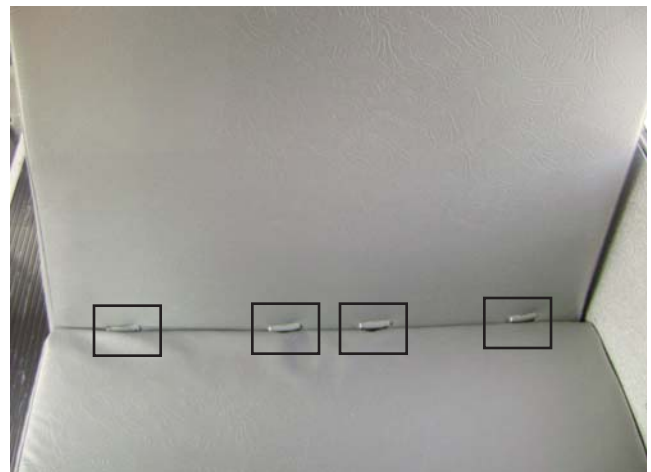

**SynTec ISO Seat
(number of ISO latches may vary)**

Installing Track Seating

It is important that you follow each bullet point listed below to insure that the seat is installed in a safe manner. When installing track seating, all federal regulations must be followed. Any information that contradicts federal regulation please disregard and contact Thomas Built Bus.

- When installing track seating all federal regulations must be followed.
- Each seat must be installed behind another seat or barrier of matching or greater width. For example, a 30" seat can be installed behind a 39" seat, but a 39" seat cannot be installed behind a 30" seat.
- When installing seats a minimum 12" clear aisle must be maintained. Figure 5 shows an example of measuring aisle space. Typically two 39" seats, side by side, are the largest two seats that can be placed beside one another and still allow for a 12" clear aisle.



Aisle Width Measurement

- All track seats must be mounted forward facing.

- When reinstalling a track mounted seat, it is recommended that it is installed in the same location, with the same hardware as it was originally installed. Seats must conform to the allowable knee room spacing for each particular seat. Please refer to the knee room section of the manual. If you are unsure of the knee room required, please contact the manufacturer.
- Not all track seats are installed with the same number of fasteners. Please contact the manufacturer if you are unsure of how many fasteners are required.
- Track mounted fasteners are required to be torque to 20-25 ft lbs to insure proper installation.
- Track seats will be installed in 1" increments.
- Seat Spacing will be determined Federal and State specifications.
- Most seats will have a Min knee room of 24" and a Max knee room of 24" plus H-point.

See example of an IMMI seat track installation on the next page.

Installing Track Seating (continued)

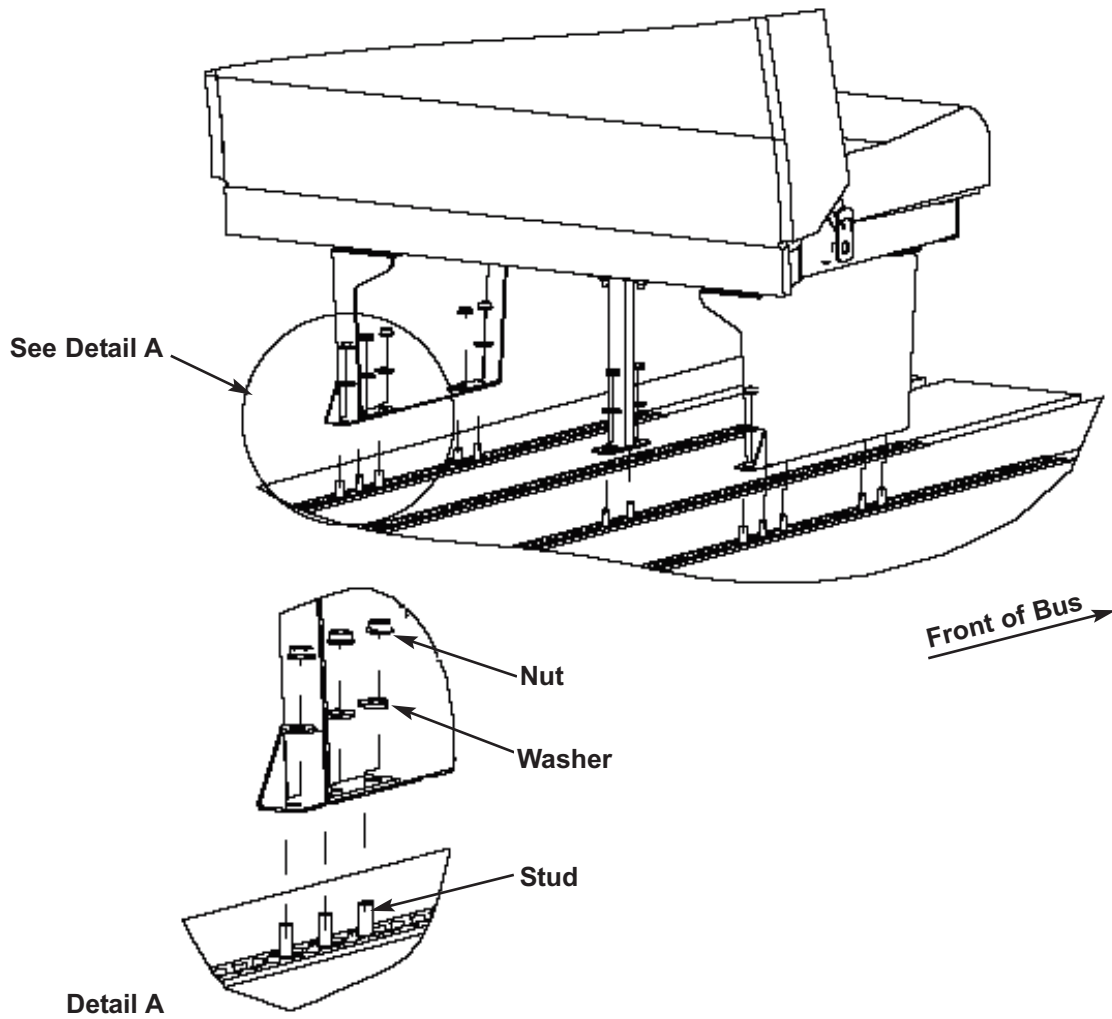

IMMI Seat Track Installation

MINOTOUR

Measuring Knee Room

It is very important that each seat be placed in the location for which it was designed. By not properly placing the seat in its correct location, you may be in violation of state and/or federal regulations and could cause injury to a passenger in the event of an accident.

Seat Spacing

If both seats are identical, seat spacing should be measured to determine the proper seat placement. Seat spacing can be measured by measuring the distance between two seats using the same reference point. A good place to measure the seat spacing is the forward most seat bolt pictured below.



Measuring Seat Spacing

Note: When measuring seat spacing both seats must be identical.

Knee Room

Knee room should be used in seat placement when the two seats are not identical. Knee room is measured from the front of the seat back to the rear of the seat back of the next seat in front of it, passing through the H point. This is also the same as seat spacing minus the seat back thickness.

For the most common spacing measurements, please refer to the "Seat Spacing Chart". If you do not see the combination of seats you have or are unsure of the proper seat spacing, please contact Thomas Built Buses for proper seat spacing.

Wheelchair Restraints

General information

If this unit is equipped with wheelchair placements, each wheelchair placement will have two or four track segments in the floor and one track segment above the window. This track is designed for use with securement equipment supplied by TBB approved vendors, Q'Straint and Sure-Lok. Use with any other straps or tiedowns is not recommended.

The restraint system consists of wheelchair tiedowns and occupant restraint belts. The wheelchair restraints secure the wheelchair to the floor and the occupant restraint belts secure the passenger to the wheelchair.

Note: Refer to the operation instructions supplied with the restraint system for proper use and safety information.

Securing the Wheelchair

The wheelchair must be forward facing. It should be centered between the four attachment points on the floor track. The wheelchair must be secured with two front and two rear tiedowns. If there are more than two track segments in front of the wheelchair, use the outer two tracks. If there are more than two track segments behind the wheelchair, use the inner two tracks. It is important to refer to the instructions provided by the manufacturer of the tiedowns for use and safety information.

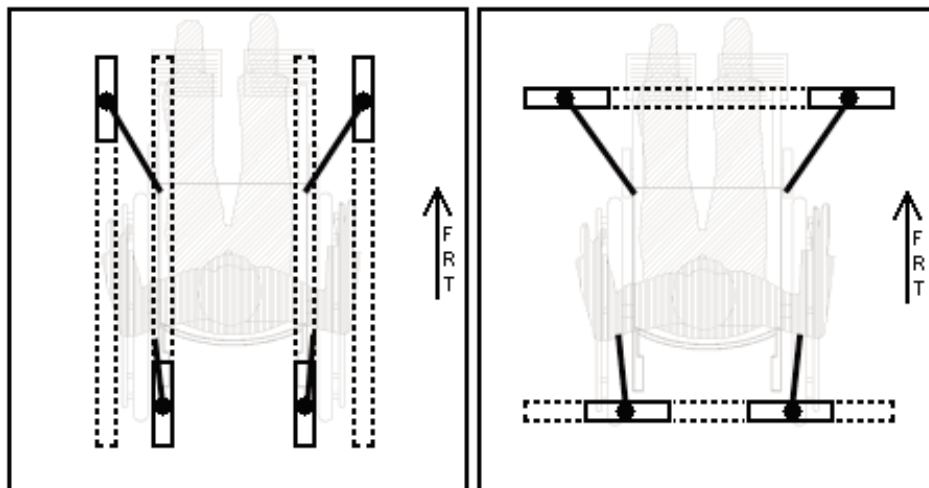

Securing the Occupant

The occupant must be secured with an upper torso belt occupant tiedown and pelvic belt occupant tiedown. The torso occupant tiedown must be secured to the overhead track above the window. It is important to refer to the instructions provided by the manufacturer of the occupant restraints for use and safety information.

Window Handle Clearance

All emergency window release handles must have a two-inch minimum clearance to allow unobstructed access in the event of an emergency. This is especially important when positioning track seats.

Note: Refer to FMVSS 217 for additional information.

Seats must be positioned so that emergency window release handles are located outside the 2" clear zone shown below.

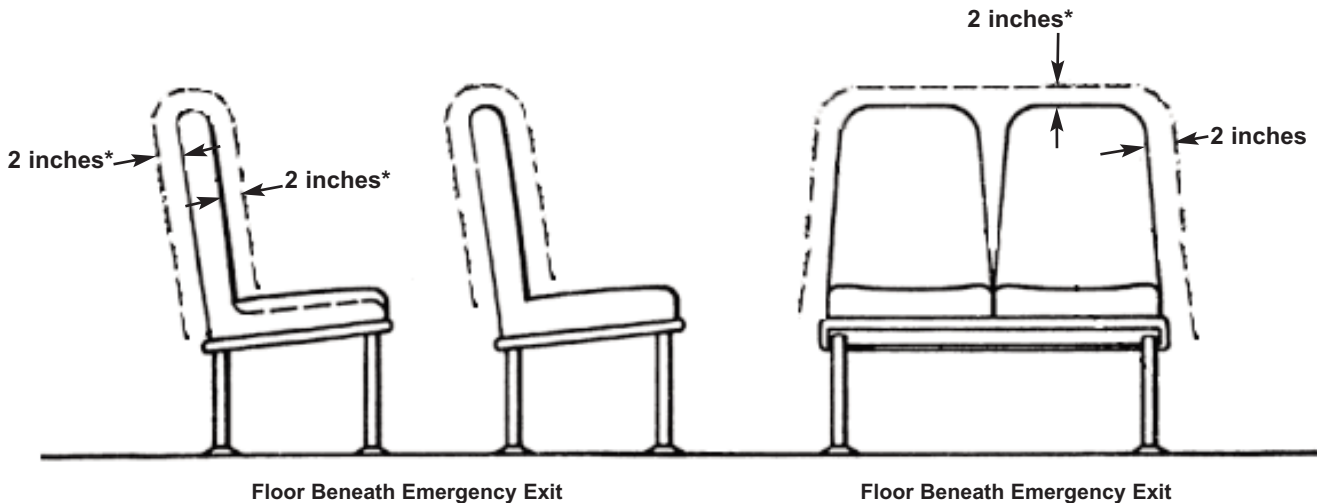

VIEW PARALLEL TO SEAT BACK

VIEW PERPENDICULAR TO SEAT BACK

*Clearance area around seat back, arm rests, and other obstructions

Access region is the spatial volume created by the intersection of the projections of the areas shown in the two views.

Wheelchair Tiedown

Several combinations of wheelchair securement systems are available through Thomas. Each one has unique characteristics while accomplishing the same goal.

For information on the proper use and care of the specific setup on your vehicle, consult the manufacturer's Instruction Guide supplied with the vehicle.

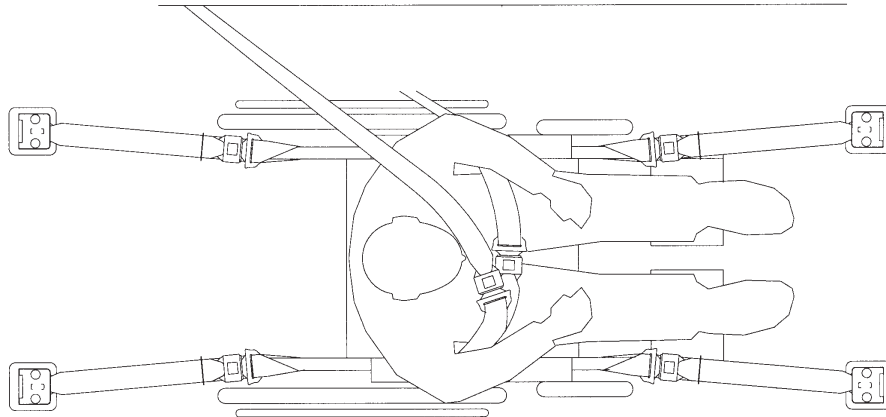

Vendor Lifts

For information on the proper use and care of the specific setup on your vehicle, consult the manufacturer's Instruction Guide supplied with the vehicle. Below is a list of these manufacturers.

- Ricon Corporate Headquarters
7900 Nelson Road
Panorama City, CA 91402
(800) 322-2884
- Maxon Lift
11921 Slauson Avenue
Santa Fe Springs, CA 90670-221
(562) 464-0099
- Automotive Innovations Inc. (Braun Lifts)
4 First Street
Bridgewater, MA 02324
(508) 697-8324

MINOTOUR

Wheelchair Lift (Optional)

Refer to the lift manufacturers operating instruction for your specific lift type.

Buses with the wheelchair lift option include a brake interlock. The brake interlock applies the vehicles parking brake and locks the gear shifter in the park position.

Follow the steps below for proper operation of the wheel chair lift and brake interlock.

1. Put the vehicle gear shifter in the park position.
2. Depress the park brake pedal to engage the parking brake.
3. Turn on the lift power switch located in the overhead switch cabinet.

4. Open the side lift door and secure it with the door chain.
5. Refer to lift manufactures' instructions to open, load, and close lift system.
6. Repeat steps 1 - 4 in reverse order before attempting to drive bus.



Body Repair

If body repairs become necessary consult your local Thomas dealer for assistance.

Air or Electric Stop Arms/Crossing Arms

All stop arms and crossing arms draw from the on-board chassis electrical system. The connection to the chassis system should never be changed since it is located so that a defective stop arm/crossing arm could never short the electrical system. The plumbing or wiring varies widely for different makes of chassis.



Stop arm/crossing arm assemblies are purchased as a kit, with many different kits available with blades to meet all state requirements. The assembly is attached to the outside of the body or bumper with sheet metal screws. This assembly requires occasional cleaning and lubrication of moving parts.

Stop arms/crossing arms are most commonly operated by a manual switch mounted in the switch panel.

Electrically controlled arms, are completely self-contained. They may be activated by the warning lamp system, a switch in the driver's area or a switch at the entrance door.

Drivers should be familiar with the function and proper operation of the stop sign arm.



MINOTOUR

Passenger Advisory System - Buzzer Activation - Option B2001-00-000

- Control module mounted in driver's area activates emergency exit buzzer after driver shuts off ignition switch.
- Includes pilot light on the switch cabinet with an information label with the following wording, "PERFORM POST-TRIP INSPECTION, DISABLE ALARM AT REAR OF BUS".
- Buzzer sounds in drivers switch cabinet area when driver shuts off ignition switch.
- When buzzer sounds a pilot light labeled "POST TRIP INSPECTION", will flash on switch panel.
- To deactivate system driver must walk to back of bus and press reset switch mounted on rear interior hood.
- Montgomery County, Maryland specification

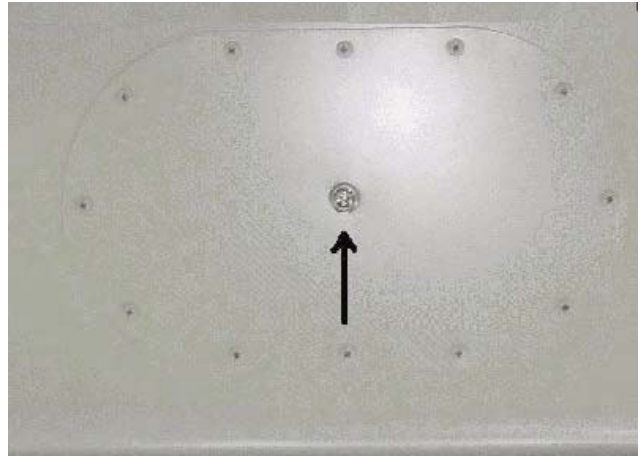

Passenger Advisory System - Horn Activation - Option B2001-02-000

- System is activated when warning light system has been activated and driver shuts off ignition switch.
 - The interior lights will come on at this time for added visibility.
 - If driver attempts to open front door (manual or air) without deactivating system the horn will sound.
 - On air doors, horn will sound even if driver turns air door emergency release valve to Emergency Exit.
 - To deactivate system, driver has to make sure front door switch is in the closed position. If it's an air door, make sure "Door Switch" on electrical panel is off and the release valve is in the "Normal" operating position.
 - With the ignition key off, driver must then walk to the back of the bus and press reset switch mounted on rear interior hood. When you press switch, hold in until you see the dome lights flicker off and on.
 - The dome lights will stay on for about 30 seconds and then go off.
- Driver is then able to exit the bus.
 - LED light on the switch panel indicates when the system is armed.
 - West Virginia specification

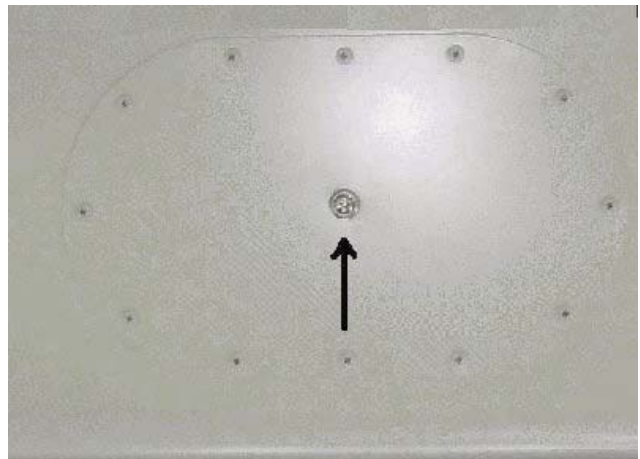

Passenger Advisory System - Buzzer Activation - Option B2001-03-000

- Bus scan child reminder system.
- Buzzer on control module will sound when the driver shuts off the ignition switch.
- The driver has 60 seconds to walk to the rear of the bus and press the reset button mounted on the rear interior hood, or the horn will activate.
- The system is deactivated when reset switch is pressed.
- Control module has a LED light to indicate when the system is armed.
- The driver is able to exit the bus after deactivating the system.

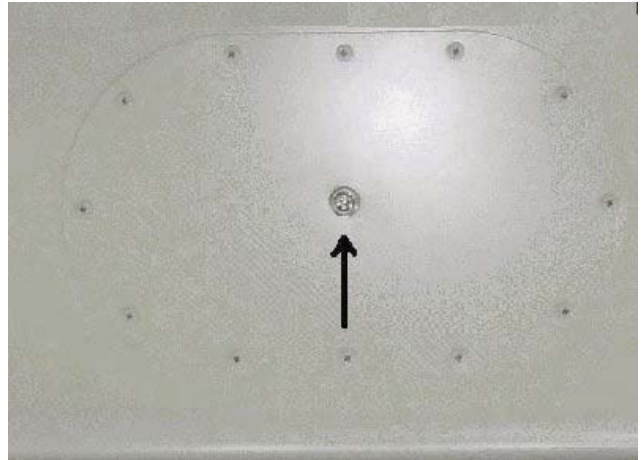

MINOTOUR

Passenger Advisory System - Horn Activation (Check Mate) - Option B2001-04-000

- System is activated when driver turns on ignition and starts the vehicle.
- An audible alarm buzzer will sound for a few seconds, and then the horn sounds, alerting that the system is activated.
- Control module mounted in driver's area activates when the warning light system has been activated and driver shuts off ignition switch.
- The driver must then turn the ignition key back on, walk to the back of the vehicle, and press the deactivation switch for at least one (1) second for the system to deactivate properly. This switch is mounted on the rear interior hood, above rear door.
- A deactivation signal (a rapid chirping noise) will sound, indicating that the system has been successfully deactivated.



Passenger Advisory System - Horn Activation (Check Mate) - Option B2001-05-000

- System is activated when driver turns on ignition and starts the vehicle.
- An audible alarm buzzer will sound for a few seconds, and then the horn sounds, alerting that the system is activated.
- Control module mounted in driver's area activates when the warning light system has been activated and driver shuts off ignition switch.
- The driver must then turn the ignition key back on, walk to the back of the vehicle, and press the deactivation switch for at least one (1) second for the system to deactivate properly. This switch is mounted on the rear interior hood, above rear door.
- A deactivation signal (a rapid chirping noise) will sound, indicating that the system has been successfully deactivated.
- LED light on switch panel indicates when the system is armed.
- System configured to conform to California's escort law:
 - Allows driver to engage warning lights without depressing the child reminder button at rear of the bus.



Passenger Advisory System - Buzzer Activation - Option B2001-07-000

- Bus scan child reminder system.
- Control module mounted in driver's area is activated after warning have been activated.
- Buzzer on control module will sound when the driver shuts off the ignition switch.
- The driver has thirty (30) seconds to walk to the rear of the bus and press the reset button mounted on the rear interior hood, or the horn will activate.
- The system is deactivated when reset switch is pressed.
- Control module has a LED light to indicate when the system is armed.
- The driver is able to exit the bus after deactivating the system.
- Michigan SBO/APT Aggregate specification
- Model BS-100SA



Child Reminder System - Option B2001-08-000

- The system arms with the ignition.
- When the ignition is shut off the interior lights will illuminate for added view.
- There is a sixty (60) second delay in which the system can not be disarmed, after which the lights will flash to confirm deactivation can take place by pushing a button.
- At this point you have three (3) additional minutes to deactivate the system. If the system is not deactivated the horn will honk until the button is pushed to deactivate.
- When deactivated, the lights will flash to confirm deactivation.
- The operating instructions are attached to the "Electrical Panel Door" if reference is needed.
- Required on all KinderCare vehicles.

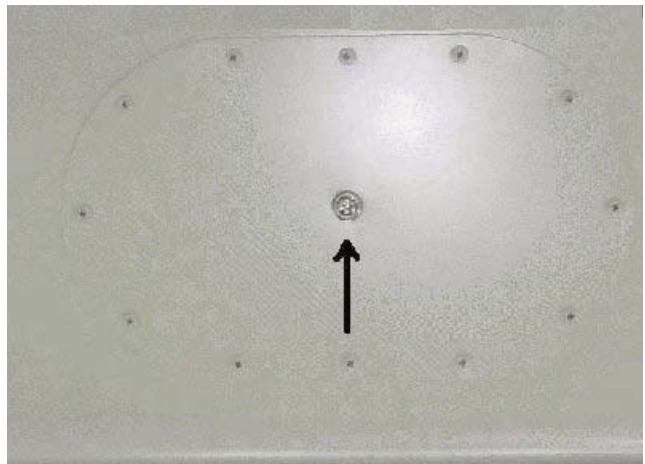

MINOTOUR

Passenger Advisory System - Horn Activation - Option B2001-11-000

- The system is activated when the warning light system has been activated and driver shuts off ignition switch.
- the interior lights and audible buzzer will come on at this time for added visibility.
- If the driver attempts to open the front door (manual or air), without deactivating the system, the horn will sound.
- On air doors, the horn will sound even if the driver turns the air door emergency release valve to Emergency Exit.
- To deactivate the system, the driver has to make sure the front door switch is in the closed position. If it is an air door, make sure the "Door Switch" on the electrical panel is off and the release valve is in the "Normal" operating position.
- With the ignition key off, the driver must then walk to the rear of the bus and press the reset switch mounted on rear interior hood. When you press the switch, hold it in until you see the dome lights blink off and on.
- The dome lights will stay on for approximately 40 seconds and then go off.
- The driver is then able to exit the bus.
- LED light on the switch panel indicates when the system is armed.

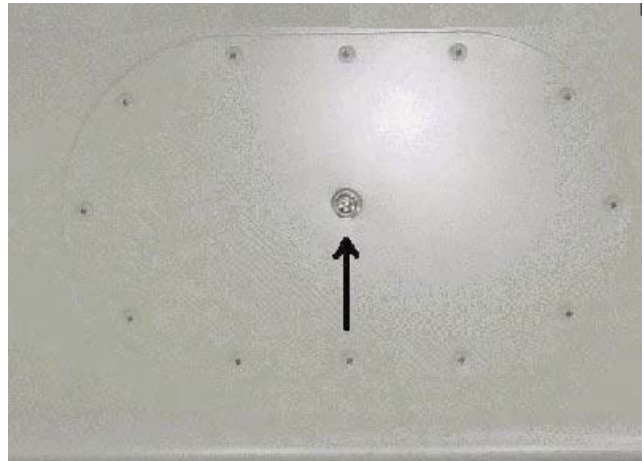

Passenger Advisory System - Horn Activation - Option B2001-13-000

- The system is activated when the warning light system has been activated and driver shuts off ignition switch.
- The interior lights will come on at this time for added visibility.
- If the driver attempts to open the front door or driver's side door, without deactivating the system, the horn will sound.
- To deactivate the system, the driver has to make sure the front door switch is in the closed position.
- With the ignition key off, the driver must then walk to the rear of the bus and press the reset switch mounted on rear interior hood. With the switch pressed, hold it in until the dome lights blink off and on.
- The dome lights will stay on for approximately 30 seconds and then go off.
- The driver is then able to exit the bus.
- LED light on the switch panel indicates when the system is armed.
- Tennessee specification

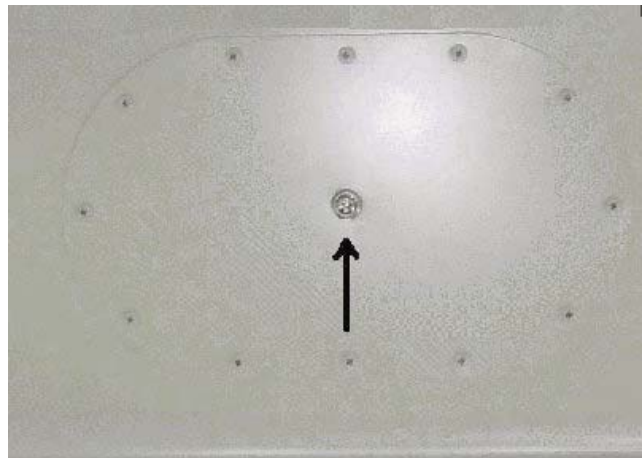

Child Reminder System - Option B2001-16-000

- The system is activated ten (10) minutes after starting vehicle and closing service door.
- When the driver shuts off ignition, interior lights will illuminate and an LED light (mounted on the electrical compartment door) will also illuminate, indicating that the driver must walk to the back of the bus and deactivate the system.
- To deactivate the system, the driver must press the deactivator button (located on the rear bulkhead beside the A/C evaporator) once.
- The system will flash the interior lights twice to confirm deactivation and leave the interior lights on for 20 seconds.
- If the driver attempts to leave the bus without deactivating the system, the horn will immediately begin to honk and the vehicle warning lights will flash.
- If the horn does honk and the vehicle warning lights flash, the driver must reenter the bus, close the door, restart the vehicle and go through the deactivation process.
- Operation also includes left side driver's door as well as front entrance door.
- Operating instructions are to be attached to the "Electrical panel door" also.
- Will not activate if started and service door remains open.
- Florida specifications.

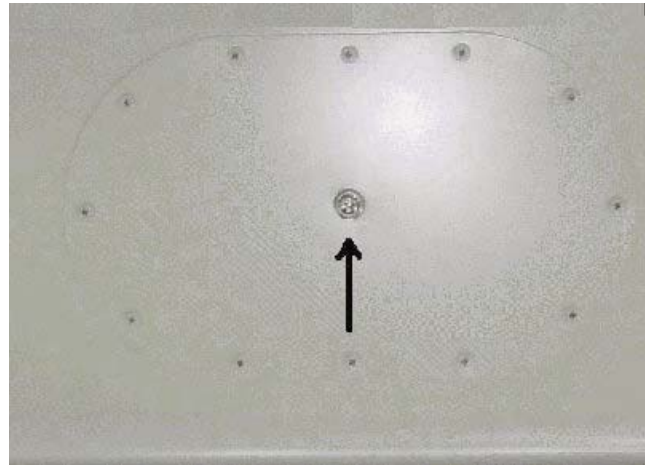

Child Reminder System EP2 - Option B2001-17-000

- The system is activated when the warning light system has been activated and driver shuts off ignition switch. When the warning lamp system has been activated for the first time, two long high-pitched beeps will sound.
- The interior lights will come on at this time for added visibility.
- If the driver attempts to open the front door without deactivating the system, the horn will sound.
- To deactivate the system, the driver has to make sure the front door switch is in the closed position. Turn the ignition key OFF for one (1) second and then to the IGNITION or ACC, the driver must then walk to the rear of the bus and press the reset switch mounted on rear interior hood. The switch is pressed and held for three (3) seconds.
- The dome lights will stay on for approximately sixty (60) seconds and then go off.
- The driver is then able to exit the bus.
- Theft-Mate system will activate one (1) minute after bus is empty.
- Dome lights will activate and vehicle horn will sound when motion is sensed after the first thirty (30) minutes.
- After thirty (30) minutes if motion is sensed, the system will sound a loud pulse of the vehicle horn five (5) times.

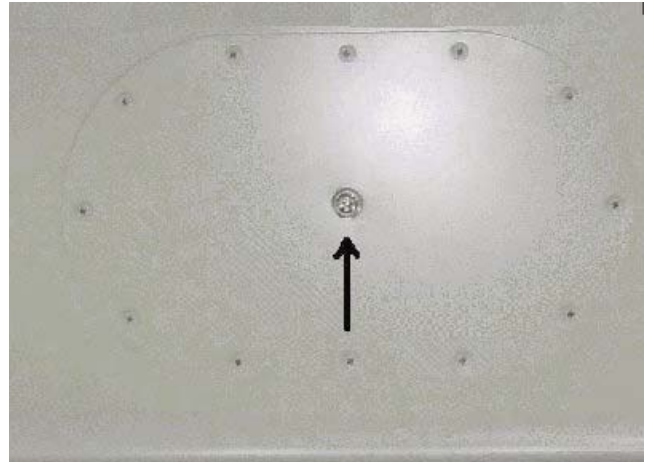

Defroster Fans (Optional)

The defroster fans are used to help clear the windshield and driver's window for better visibility. The fans run at either low or high speed. The fans must be cleaned and the fasteners tightened occasionally.



Backing Horn & Heavy Duty Backing Alarm

The backing horn or heavy duty backing alarm is mounted at the rear underbody and signals automatically when chassis transmission is placed in reverse. It is powered by the reverse light circuit.

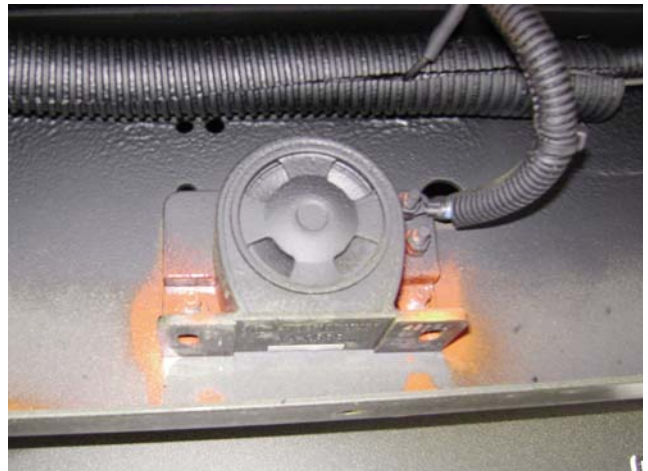

This section provides the operator with important information about coach maintenance. Proper coach maintenance is essential to ensuring coach reliability and dependability. Proper maintenance should start with a good preventive maintenance program. Periodic inspections by qualified personnel are the key to eliminating costly and expensive failures and downtime.

The following are minimum preventive maintenance inspections that should be performed as shown on the forms or more often as operational and climatic conditions dictate.

Electrical Circuit Protection

The body electrical system is protected by 120-amp circuit breaker. This circuit breaker is mounted under the chassis hood above the battery on the Ford Chassis. On the GM Chassis it is located in a box inside the bus, to the right of the stepwell.

All power to the body will pass through this circuit breaker on its way to the electrical panel located above the driver. A master solenoid distributes the power to circuits requiring battery current and others requiring ignition current.

Each circuit is protected from overload damage by fuses/circuit breakers. Should an electrical component fail to operate, check the appropriate fuse.

Fuses that open (blow) must be replaced. A fuse will continue to blow until the cause of an overload condition is corrected. If a fuse needs to be replaced, use only a new fuse, rated according to specifications.

Warning: Any addition of accessories which exceed the capacity of the electrical system, or any modification of the system - such as bypassing a fuse, could cause premature failure of electrical components. Any such addition of accessories, or modifications may affect your rights under the warranty.

Note: No aftermarket accessories should be added.

Warning: Always replace a fuse with the same rating as specified. Never replace with a higher amperage rating because severe wiring damage and possible fire can result.

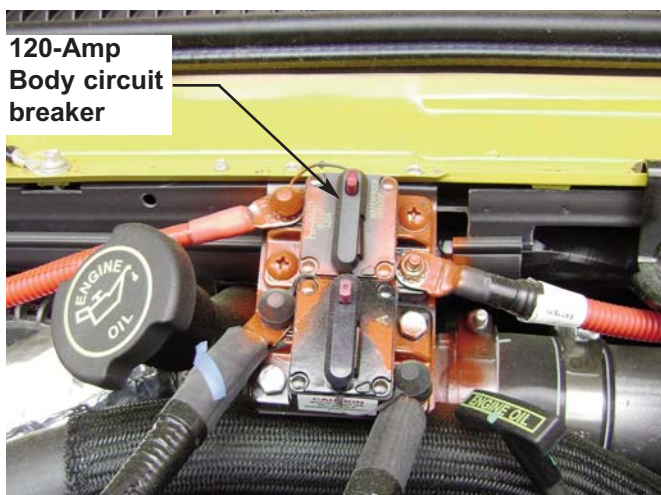

Ford Chassis: Circuit Breaker mounted under the chassis hood above the battery.

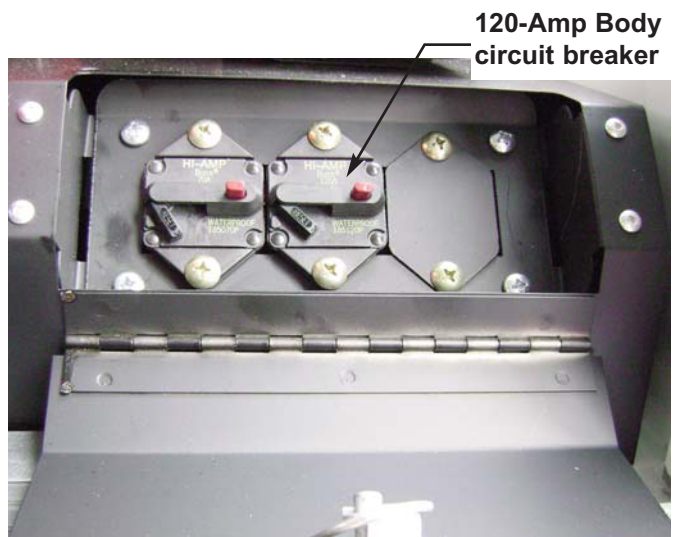

GM Chassis: Circuit Breaker located in a box inside the bus to the right of the stepwell.

MINOTOUR

Electrical Circuit Protection *(continued)*

Circuit breakers are available in lieu of fuses to protect the electrical system. Should an electrical component fail to operate, check the appropriate circuit breaker.

⚠ Warning: Always replace a circuit breaker with the same rating as specified. Never replace with a higher amperage rating because severe wiring damage and possible fire can result.

⚠ Warning: Any addition of accessories which exceed the capacity of the electrical system, or any modification of the system - such as bypassing a circuit breaker, could cause premature failure of electrical components. Any such addition of accessories, or modifications may affect your rights under the warranty.

Circuit breakers that open must be reset, but will continue to open until the cause of the overload condition is corrected. If a circuit breaker needs to be replaced, use only a new circuit breaker, rated according to specifications.

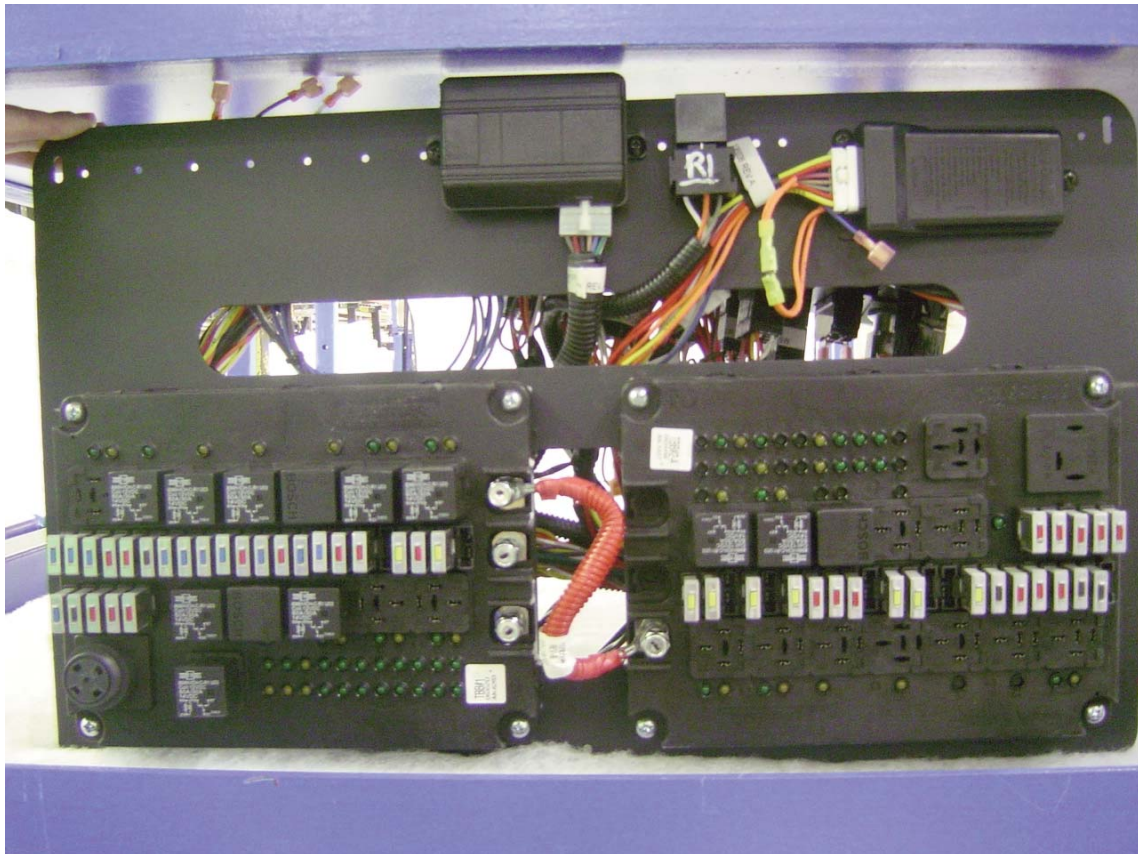

Bulb Replacement

Interior Lights

<u>Light</u>	<u>Bulb Part #</u>
Interior Dome	TBB 22068365
Side Emergency	TBB 85520048
Stepwell	TBB 85520048
Switch Panel	TBB 22064365

Exterior Lights

<u>Light</u>	<u>Bulb Part #</u>
Back-up	TBB 22069365
Front Directional	TBB 85520049
Front Directional-Arrow Type	TBB 22069365

Side Directional

<u>Light</u>	<u>Bulb Part #</u>
Front Parking	TBB 85520050
Marker/Clearance	TBB 22065365
Rear Directional	TBB 22069365
Stop	TBB 22069365
Stop/Tail	TBB 22009367
Warning Lights	TBB 22003369

Heating System

All heaters have removable aluminum filters. These filters prevent debris from accumulating on the heater core and causing inefficient heat transfer. Use an air hose to remove all foreign material from the filters every 30 days.

Check the condition of all hoses to the heaters as well as the tightness of the hose clamps. The heater hoses should not be kinked.

All heater hose clamps should be tightened after 30 days.

When system coolant is replaced, it is important to bleed all air from the heater units. The bleeder valve, located in the return line in the engine compartment, should be opened and remain open until a steady stream of coolant flows from the valve.

Note: Silicone hoses require special constant torque clamps.

Antifreeze

Consult the chassis manufacturer's manual.

MINOTOUR

Floor Covering

Cleanliness is important to you and your passengers, and will give you longer floor life. Allowing dirt and other abrasive materials to accumulate on the floor will shorten the life of the coach floor covering. Daily sweeping and cleaning is recommended. Do not use floor sweeping compounds as it may cause floor covering to separate or lift from the floor. The recommended sweeping procedure is to start in the front of the body and sweep toward the rear and side emergency door. This method ensures a check of emergency door operations and ensures removal of dirt, pencils, etc., which cause the emergency door to improperly seal. Do not use harsh detergents and excessive amounts of water. Mop with a mild soap solution, then remove excess water.

Oil and grease quickly deteriorate the floor covering. Remove as soon as possible.

Wax floor occasionally for best appearance and floor life. The use of a non-skid type floor wax is suggested.

To renew the luster and close the pores of the floor covering after extended use, mix 10% Clorox or commercial bleach to 90% water and mop the floor.

Washing

For the first 30 days, wash the coach only with clean water. Do not use a high pressure hose or detergent during this period. Operating conditions will dictate washing frequency. Special attention must be given to removing salt deposits when coach is operated in areas that use salt. Failure to do so may cause serious damage to sheet metal and painted surfaces, which could invalidate your warranty.

Waxing

Waxing is recommended to eliminate any weathered appearance. A good automotive wax may be applied after the first 30 days of service. Annual waxing should be standard procedure for additional corrosion protection and longer paint life, and to maintain your current warranty status.

Touch-Up

Retouch damaged areas as soon as possible to benefit coach appearance and control corrosion. Exposed metal quickly corrodes and repair may

develop into a major expense. Your Thomas dealer may be your paint source. The following is a list of the most common Thomas colors:

Thomas Part Number (Gallon Can)

<u>COLOR</u>	<u>THOMAS PART #</u>
SCHOOL BUS (CHROME) YELLOW	TBB 68000893
LIGHT BLUE	TBB 28007375
MEDIUM BLUE (EXT. AIR DRY)	TBB 28009377
DARK BLUE (EXT. AIR DRY)	TBB 28010377
WIND BLUE (AIR DRY)	TBB 28008377
LIGHT GREEN (AIR DRY)	TBB 28021367
MEDIUM GREEN (AIR DRY ENAMEL)	TBB 28015377
DARK GREEN (EXT. AIR DRY)	TBB 28016377
SHENANDOAH GREEN (AIR DRY)	TBB 28017377
FLAME RED (AIR DRY ENAMEL)	TBB 28011377
MEDIUM RED (EXT. AIR DRY)	TBB 28012377
DARK RED (EXT. AIR DRY)	TBB 28013377
WHITE (AIR DRY ENAMEL)	TBB 28022370
BLUETONE WHITE	TBB 68000426
TAN (AIR DRY ENAMEL)	TBB 28002378
CREAM	TBB 28014377
LIGHT GREY (EXT. AIR DRY)	TBB 28023377
MEDIUM GREY (EXT. AIR DRY)	TBB 28024377
MINN. ORANGE (AIR DRY)	TBB 28026377
OMAHA ORANGE (AIR DRY)	TBB 28021377
DESERT BEIGE (AIR DRY ENAMEL)	TBB 68000652
SILVER MET (AIR DRY)	TBB 68000245
GOLD (EXT. AIR DRY)	TBB 28019376
WINTER WHITE (POLYURETHANE)	TBB 68000627
BROWN (HIGH SOLIDS)	TBB 68000829
BLACK (POLYURETHANE GLOSS)	TBB 68000807
MINOTOUR GRILLE	

MINOTOUR

Floor (Underneath Bus)

Accumulations of mud, snow and road salts should be removed with a high pressure hose. Follow this procedure at intervals of 30 days to six months, depending upon your operation and environmental conditions.

This cleaning procedure will also give you the opportunity to make an efficient check of your mounting clips and bolts. Mounting clips and bolts should be inspected for secure fit every thirty days.

Excessive amounts of chemicals, salt and other snow and ice controls materials add to the deterioration of metal on all vehicles on our highways and roads today.

As an added method, you should clean the entire underside of the floor of all foreign elements annually and re-undercoat if chemical action is apparent, or separation of undercoat to body floor is visible. Climatic and operating conditions should dictate if underfloor inspection should be performed more often.

Windshield Washer

To add windshield washer fluid, locate the fluid reservoir behind the left windshield wiper access panel below the windshield. Use a suitable washer fluid (not water) and fill to the cap.

Proper Disposal of Fluids



Caution: Be mindful of the environment and ecology. Before you drain any fluids, find out the proper way to dispose of the fluid.

Do not pour oil onto the ground, down a drain, or into a stream, pond or lake. Consult local ordinances that govern the disposal of wastes.

Driver's Daily Inspection & Condition Report

Bus Number _____ **Date/Time** _____

Mileage _____ **Location** _____

Maintenance Department

	OK	Not OK
1. Fill windshield washer container	_____	_____
2. Visual inspection of exterior for damage	_____	_____
3. Start engine. Check operation of the following:	_____	_____
a. Heater/Air conditioner	_____	_____
b. Windshield wiper and washer	_____	_____
c. All interior lights	_____	_____
d. Turn signals, stop lamps	_____	_____
e. Headlights, clearance lights	_____	_____
f. All warning devices - stop sign, warning lights, horn	_____	_____
g. Maximum air system pressure (110 - 120 psi)	_____	_____
h. Door controls	_____	_____
4. Inspect seat backs and cushions for cuts, rips	_____	_____
5. Check condition of all rear view mirrors, adjust mirrors as necessary	_____	_____
6. Move bus to ready line. En route, check operation of brakes and steering	_____	_____
7. Check to make sure all exterior doors are closed securely	_____	_____
8. Inspect driver's seat belt for condition and operation	_____	_____

Driver's Signature _____

Comments:

Preventive Maintenance Inspection #1

3,000 Miles, 5,000 Km - Monthly

Unit Number _____

Mileage _____

Repair Order # _____

Date/Time _____

Location _____

✓ = OK

X = Attention Required

R = Repair

N/A = Not Applicable

	OK	Not OK
1. Check driver's reports for problems previously reported	_____	_____
2. Start engine. Check operation of the following:		
a. Check interior lights ___ Dash lights ___ Ceiling lights ___	_____	_____
b. Check exterior lights ___ Headlights ___ High beam indicator ___	_____	_____
Tail ___ Stop ___ Stepwell ___ Clearance ___	_____	_____
c. Check 4-light warning system ___ 8-light warning system	_____	_____
d. Check Windshield wiper operation ___ Washer ___	_____	_____
e. Check heater operation ___ Air conditioner ___	_____	_____
3. Inspect condition of windshield ___ Side glasses ___ Mirrors ___	_____	_____
4. Inspect condition of wiper blades ___ Fill washer container ___	_____	_____
5. Inspect front door assembly hinges ___ Controls ___ Adjustments ___	_____	_____
6. Inspect seat back and cushion for damage ___ Check frames ___	_____	_____
7. Inspect condition of floor covering ___ Upholstery ___	_____	_____
8. Inspect and operate all emergency exits "opening/closing"	_____	_____
9. Check operation of all door and window warning buzzers	_____	_____
10. Check operation of all roof hatches and warning buzzers	_____	_____
11. Inspect exterior sheet metal for damage: Corrosion ___ Paint Condition ___	_____	_____
12. Inspect lock condition, all external access doors	_____	_____
13. Inspect battery installation, hold-down clamps security	_____	_____
14. Inspect battery cables for corrosion, chafing	_____	_____
15. Inspect body mounting bolts and clips for security	_____	_____
16. Road test. Check brake operation, unusual noises, etc.	_____	_____
17. Wipe grease off steering wheel and driver's seat	_____	_____
18. Fill out all required work orders, forms, etc.	_____	_____
19. If diesel, test coolant for freeze protection and SCA levels	_____	_____

Mechanic's Signature _____

Comments:

Preventive Maintenance Inspection #2

45,000 Miles, 75,000 Km - Annual

Unit Number _____
 Mileage _____
 Repair Order # _____
 Date/Time _____
 Location _____

✓ = OK
 X = Attention Required
 R = Repair
 N/A = Not Applicable

	OK	Not OK
1. Perform #1 Inspection	_____	_____
2. Inspect hoses for deterioration - replace as required	_____	_____
3. Replace coolant every 2 years. (Management decision)	_____	_____
4. Remove covers, all heaters - clean cores, clean filters	_____	_____
5. Check operation of all heater motors, defrosters	_____	_____
6. Tighten all hose clamps - air intake system	_____	_____
7. Inspect rubber seals on emergency exits	_____	_____
8. Lubricate all access and emergency door hinges	_____	_____
9. Inspect all windows for proper latching	_____	_____
10. Check operation of restriction indicator, remove and test operation, if so equipped . . .	_____	_____
11. Steam clean engine compartment, if necessary	_____	_____
12. Check fuel sender unit connections and renew dielectric grease, if necessary.	_____	_____
Check fuel fill hose for tightness	_____	_____
*13. Check and clear weep holes over the windshield for drainage	_____	_____

Mechanic's Signature _____

Comments:

Thomas Built Buses, Inc.
1408 Courtesy Road
Post Office Box 2450
High Point, NC 27261
(336) 889-4871

Part #TBB 41000293 (rev 2020.03.06)



©2010 Thomas Built Buses, Inc. All rights reserved. No portion of this catalog may be reproduced by any means without express permission from the copyright holder.

Thomas Built Buses, Inc. is a subsidiary of Daimler Trucks North America LLC, a Daimler Company